

SERVOSTAR 300

Digital Servo Amplifier S300

Instructions Manual



Edition: May 2020

Translation of the original instructions.

Valid for Hardware Revision 04.20



For safe and proper use, follow these instructions.
Keep them for future reference.



Record of Document Revisions:

Revision	Remarks
...	Table with life cycle information of this document see (→ # 141)
04/2018	X1 connector (male->female), HR table updated, Wiki links migrated to KDN, ventilation corrected
11/2018	Layout of the warning notes updated, user expertise updated, new readers note on cover page
05/2020	Layout updated, chapter "Used Standards" removed, motor temperatur sensor generalized, chapter normal operation added, RoHS, REACH, EAC, PROFINET expansion card

Hardware Revision (HR)

Hardware Rev.	Firmware Rev.	Export Classification	Remarks
02.01	2.18 - 3.74	AL-3A225	Start HR
02.10 (03.01)	3.75 - 4.99	AL-3A225	AS->STO, new approval
04.00	5.18 - 5.99	AL-3A225	New CPU, front label S300
04.10	5.18_ND0 - 5.99_ND0	-	New data structure
04.20	≥ 6.00_ND0	-	SFD3/DSL support

Trademarks

- WINDOWS is a registered trademark of Microsoft Corp.
- HIPERFACE is a registered trademark of Max Stegmann GmbH
- SERCOS is a registered trademark of sercos® international e.V.
- PROFIBUS and PROFINET are registered trademarks of PROFIBUS and PROFINET International (PI).
- EnDat is a registered trademark of Dr. Johannes Heidenhain GmbH
- EtherCAT is a registered trademark and patented technology, licensed by Beckhoff Automation GmbH.

Technical changes which improve the performance of the device may be made without prior notice!

This document is the intellectual property of Kollmorgen. All rights reserved. No part of this work may be reproduced in any form (by photocopying, microfilm or any other method) or stored, processed, copied or distributed by electronic means without the written permission of Kollmorgen.

1 Table of Contents

1 Table of Contents	3
2 General	9
2.1 General	9
2.2 Using the PDF Format	9
2.3 Symbols Used	10
2.4 Abbreviations Used	11
3 Safety	12
3.1 You should pay attention to this	12
3.2 Warning notes placed on the product	14
3.3 Use as Directed	15
3.4 Prohibited Use	15
4 Product life cycle handling	16
4.1 Transport	16
4.2 Packaging	16
4.3 Storage	16
4.4 Installation, setup and normal operation	16
4.5 Decommissioning	17
4.6 Maintenance and cleaning	17
4.7 Disassembly	17
4.8 System Repair	18
4.9 Disposal	18
5 Approvals	19
5.1 Conformance with UL/cUL	19
5.2 Conformance with CE	20
5.2.1 European Directives and Standards for the machine builder	20
5.2.2 Functional Safety Conformance (STO) according to EC Machinery Directive	21
5.2.3 Conformance with RoHS	21
5.2.4 Conformance with REACH	21
5.3 Conformance with EAC	21
6 Package	22
6.1 Package Supplied	22
6.2 Nameplate	22
6.3 Part Number Scheme	23
7 Technical description	24
7.1 The SERVOSTAR 300 family of digital servo amplifiers	24
7.2 Technical Data	26
7.2.1 Technical Data 110 / 230 V (Types S3__6_)	26
7.2.2 Technical Data 230V ... 480 V (types S3__0_)	27
7.2.3 Inputs / outputs, Auxiliary voltage	28
7.2.4 Connectors	28
7.2.5 Recommended Tightening Torques	28
7.2.6 Fusing	28
7.2.7 Ambient Conditions, Ventilation and Mounting Position	29
7.2.8 Conductor cross-sections	29
7.3 Motor holding brake	30
7.4 LED display	31
7.5 Grounding system	31
7.6 Dynamic braking (brake circuit)	31
7.7 Switch-on and switch-off behavior	33
7.7.1 Behavior in standard operation	34

7.7.2 Behavior in the event of an error (with standard setting)	35
7.8 Stop-, Emergency Stop-, Emergency Off Function to IEC 60204	36
7.8.1 Stop	36
7.8.2 Emergency Stop	37
7.8.3 Emergency Off	37
7.9 Safe Torque Off (STO)	38
7.9.1 Safety characteristic data	38
7.9.2 Safety Notes	39
7.9.3 Use as directed	40
7.9.4 Prohibited Use STO	40
7.9.5 Technical data and pinning	40
7.9.6 Enclosure	40
7.9.7 Wiring	40
7.9.8 Functional description	41
7.9.8.1 Safe operation sequence	41
7.9.8.2 Control circuit	42
7.9.8.3 Functional test	43
7.9.8.4 Mains supply circuit	43
7.10 Shock-hazard Protection	44
7.10.1 Leakage current	44
7.10.2 Residual current protective device (RCD)	44
7.10.3 Isolating transformers	44
8 Mechanical Installation	45
8.1 Important Notes	45
8.2 Guide to Mechanical Installation	45
8.3 Mounting	46
8.4 Dimensions	47
9 Electrical Installation	48
9.1 Important Notes	48
9.2 Guide to electrical installation	49
9.3 Wiring	50
9.3.1 Shielding connection to the front panel	51
9.3.2 Technical data for cables	52
9.4 Components of a servo system	53
9.5 Block diagram	54
9.6 Connector assignment	55
9.7 Connection overview	56
9.8 Voltage supply	58
9.8.1 Connection to various mains supply networks	58
9.8.2 24V auxiliary supply (X4)	59
9.8.3 Mains supply connection (X0), three phase	59
9.8.4 Mains supply connection (X0), two phase without neutral	59
9.8.5 Mains supply connection (X0), single phase with neutral	60
9.9 DC bus link (X8)	61
9.9.1 External brake resistor (X8)	61
9.9.2 Capacitor Module KCM (X8)	62
9.10 Motor power and motor holding brake connection (X9)	64
9.11 Feedback systems	65
9.12 Primary and secondary feedback types	66
9.12.1 SFD3 (X1), single cable connection	67
9.12.2 HIPERFACE DSL (X1), single cable connection	68
9.12.3 Resolver (X2)	69
9.12.4 Sine Encoder with BiSS analog (X1)	70
9.12.5 Encoder with BiSS digital (X1)	71

9.12.6 Sine Encoder with EnDat 2.1 (X1)	72
9.12.7 Encoder with EnDat 2.2 (X1)	73
9.12.8 Sine Encoder with HIPERFACE (X1)	74
9.12.9 Sine Encoder with SSI (X5, X1)	75
9.12.10 Sine Encoder without data channel (X1)	76
9.12.11 Sine Encoder with Hall (X1)	77
9.12.12 ROD (AquadB) 5V, 1.5MHz (X1)	78
9.12.13 ROD (AquadB) 5V, 350kHz (X1)	79
9.12.14 ROD (AquadB) 5V, 350kHz with Hall (X1)	80
9.12.15 ROD (AquadB) 5V (X5, X1)	81
9.12.16 ROD (AquadB) 5V with Hall (X5, X1)	82
9.12.17 ROD (AquadB) 24V (X3)	83
9.12.18 ROD (AquadB) 24V with Hall (X3, X1)	84
9.12.19 SSI Encoder (X5, X1)	85
9.12.20 Hall sensors (X1)	86
9.13 Electronic Gearing, Master-Slave operation	87
9.13.1 Encoder control types	87
9.13.2 Connection to stepper motor controllers (step and direction)	88
9.13.2.1 Step / Direction with 5 V signal level (X1)	88
9.13.2.2 Step / Direction with 24 V signal level (X3)	88
9.13.2.3 Step / Direction with 5 V signal level (X5)	89
9.13.3 Anschluss für Master-Slave Betrieb	89
9.13.3.1 Master-Slave 5V (X1)	89
9.13.3.2 Master-Slave 5V (X5)	89
9.14 Encoder Emulation, position output	90
9.14.1 Incremental encoder output (AquadB) (X5)	90
9.14.2 SSI encoder output (X5)	91
9.15 Digital and analog inputs and outputs	92
9.15.1 Analog Inputs (X3)	92
9.15.2 Digital Inputs (X3/X4)	93
9.15.3 Digital Outputs (X3)	94
9.16 RS232 interface, PC connection (X6)	95
9.17 CAN-bus interface (X6)	96
10 Setup	97
10.1 Important Notes	97
10.2 Setup software	98
10.2.1 Use as directed	98
10.2.2 Software description	98
10.2.3 Hardware requirements, operating systems	99
10.2.4 Installation under WINDOWS	99
10.3 Quickstart, initial drive test	100
10.3.1 Preparation	100
10.3.2 Connect	102
10.3.3 Important Screen Elements	103
10.3.4 Setup Wizard	104
10.3.4.1 Basic Setup	104
10.3.4.2 Units/Mechanical	105
10.3.4.3 Motor (rotary) and Feedback	106
10.3.4.4 Motor (linear) / Feedback (Encoder)	106
10.3.4.5 Save Parameters and Restart	107
10.3.5 Motion Service (Jog Mode)	107
10.3.6 More Setup Screens	108
10.4 Multi axis system	109
10.5 Keypad operation and LED display	109

10.5.1 Operation	110
10.5.2 Status display	110
10.5.3 Standard menu structure	110
10.5.4 Advanced menu structure	111
10.6 Error messages	112
10.7 Warning messages	113
10.8 Trouble shooting	114
11 Expansions	115
11.1 Guide to installation of expansion cards	115
11.2 Expansion card -I/O-14/08-	116
11.2.1 Technical data	116
11.2.2 LEDs	116
11.2.3 Entering a motion block number (example)	116
11.2.4 Connector assignments	117
11.2.5 Connection diagram (default)	118
11.3 Expansion card -PROFIBUS-	119
11.3.1 Connection technology	119
11.3.2 Connection diagram	119
11.4 Expansion card -SERCOS-	120
11.4.1 LEDs	120
11.4.2 Connection technology	120
11.4.3 Connection diagram	121
11.4.4 Setup	121
11.5 Expansion card - DEVICENET -	122
11.5.1 Connection technology	122
11.5.2 Connection diagram	122
11.5.3 Combined module status and network status LED	123
11.5.4 Setup	123
11.5.5 Bus cable	124
11.6 Expansion card -SYNQNET-	125
11.6.1 NODE ID Switch	125
11.6.2 NODE LED table	125
11.6.3 SynqNet Connection, Connector X21B / X21C (RJ-45)	125
11.6.4 Digital inputs and outputs, connector X21A (SubD 15-pin, socket)	126
11.6.5 Connection diagram digital inputs and outputs, connector X21A	126
11.7 Expansion card - FB-2to1 -	127
11.7.1 Pinout	127
11.7.2 Wiring example with BiSS digital (primary) and SinCos (secondary)	128
11.8 Expansion card -PROFINET-	129
11.8.1 Device master file	129
11.8.2 LED	129
11.8.3 Connection technology	129
11.8.4 Connection examples	130
11.9 Expansion module -2CAN-	131
11.9.1 Installation	131
11.9.2 Connection technology	131
11.9.3 Connector assignments	132
11.9.4 Setup of Station Address and Baud Rate	132
11.10 Option "EtherCAT"	133
11.10.1 NODE LED table	133
11.10.2 Connection diagram	133
11.11 Option "FAN", ventilator control	134
12 Appendix	135
12.1 Glossary	135

12.2 Order codes	137
13 Index	139
14 Record of document revisions	141

-- / --

2 General

2.1 General

This manual describes the digital servo amplifiers of the SERVOSTAR 300 (S300, standard version, 1.5 to 10 A nominal current).

A more detailed description of the expansion cards that are currently available and the digital connection to automation systems can be found, together with our application notes, in Acrobat-Reader format on the accompanying CD-ROM (system requirements:

WINDOWS, Internet Browser, Acrobat Reader) in different languages.

Technical data and dimensional drawings of accessories such as cables, brake resistors, mains supplies, etc., can be found in the accessories manual.

This documentation (PDF) can be printed out on any standard commercial printer.

More background information can be found in our "Kollmorgen Developer Network" kdn.kollmorgen.com.











2.2 Using the PDF Format

This document includes several features for ease of navigation











Cross References	Table of contents and index include active cross references.
Table of contents and index	Lines are active cross references. Click on the line and the appropriate page is accessed.
Page/chapter numbers in the text	Page/chapter numbers with cross references are active links.

2.3 Symbols Used

Warning Symbols

Symbol	Indication
	Indicates a hazardous situation which, if not avoided, will result in death or serious injury.
	Indicates a hazardous situation which, if not avoided, could result in death or serious injury.
	Indicates a hazardous situation which, if not avoided, could result in minor or moderate injury.
	Indicates situations which, if not avoided, could result in property damage.
	This symbol indicates important notes.
	Warning of a danger (general). The type of danger is specified by the text next to the symbol.
	Warning of danger from electricity and its effects.
	Warning of danger from hot surface.
	Warning of danger from suspended loads.
	Warning of danger from automatic start.

Drawing symbols

Symbol	Description	Symbol	Description
	Signal ground		Diode
	Chassis ground		Relay
	Protective earth		Relay switch off delayed
	Resistor		Normally open contact
	Fuse		Normally closed contact

2.4 Abbreviations Used

Abbrev.	Meaning
(→ # xx)	See page xx. Example (→ # 53): see page 53.
AGND	Analog ground
BTB/RTO	Ready to operate
CAN	Fieldbus (CANopen)
CLK	Clock signal
COM	Serial interface for a PC-AT
DGND	Digital ground
Disk	Magnetic storage (diskette, hard disk)
EEPROM	Electrically erasable programmable memory
EMC	Electromagnetic compatibility
EMI	Electromagnetic interference
ESD	Electrostatic discharge
F-SMA	Fiber Optic Cable connector according to IEC 60874-2
INC	Incremental Interface
LED	Light-emitting diode
MB	Megabyte
NI	Zero pulse
PC	Personal computer
PELV	Protected low voltage
PL	Performance Level
PLC	Programmable logic controller
PWM	Pulse width modulation
RAM	Volatile memory
RB	Brake (regen) resistor
RBext	External brake resistor
RBint	Internal brake resistor
RES	Resolver
ROD	A quad B encoder
SIL	Safety Integrity Level
SIL CL	Safety Integrity Level Claim Limit
SRAM	Static RAM
SSI	Synchronous serial interface
STO	Safe Torque Off
V AC	AC voltage
V DC	DC voltage

3 Safety

This section helps you to recognize and avoid dangers to people and objects.

3.1 You should pay attention to this

Specialist staff required!

Only properly qualified personnel are permitted to perform such tasks as transport, installation and setup. Qualified specialist staff are persons with expertise in transport, installation, assembly, commissioning and operation of electrotechnical equipment.

- Transport, storage, unpacking: only by personnel with knowledge of handling electrostatically sensitive components.
- Mechanical installation: only by personnel with mechanical expertise.
- Electrical installation: only by personnel with expertise in electrical engineering.
- Basic tests / setup: only by personnel with expertise in electrical engineering and drive technology.

The qualified personnel must know and observe ISO 12100 / IEC 60364 / IEC 60664 and national accident prevention regulations.

Read the documentation!

Read the available documentation before installation and commissioning. Improper handling of the devices can cause harm to people or damage to property. The operator of systems using the drive system must ensure that all personnel who work with the drive read and understand the manual before using the drive.

Check Hardware Revision!

Check the Hardware Revision Number of the product (see product label). This number is the link between your product and the manual. The product Hardware Revision Number must match the Hardware Revision Number on the cover page of the manual.

Pay attention to the technical data!

Adhere to the technical data and the specifications on connection conditions. If permissible voltage values or current values are exceeded, the devices can be damaged. Unsuitable motor or wrong wiring will damage the system components. Check the combination of drive and motor. Compare the rated voltage and current of the units.

Observe electrostatically sensitive components!

The devices contain electrostatically sensitive components which may be damaged by incorrect handling. Electrostatically discharge your body before touching the device. Avoid contact with highly insulating materials (artificial fabrics, plastic film etc.). Place the device on a conductive surface.

Perform a risk assessment!

The manufacturer of the machine must generate a risk assessment for the machine, and take appropriate measures to ensure that unforeseen movements cannot cause injury or damage to any person or property. Additional requirements on specialist staff may also result from the risk assessment.



Automatic Restart!

The drive might restart automatically after power on, voltage dip or interruption of the supply voltage, depending on the parameter setting. Risk of death or serious injury for humans working in the machine. If the parameter AENA is set to 1, then place a warning sign to the machine (Warning: Automatic Restart at Power On) and ensure, that power on is not possible, while humans are in a dangerous zone of the machine. In case of using an under-voltage protection device, you must observe EN 60204-1.



Hot surface!

Drives may have hot surfaces during operation. The housing can reach temperatures above 80°C. Risk of minor burns! Measure the temperature, and wait until the housing has cooled down below 40 °C before touching it.



Earthing!

It is vital that you ensure that the drive is safely earthed to the PE (protective earth) busbar in the switch cabinet. Risk of electric shock. Without low-resistance earthing no personal protection can be guaranteed.

Leakage Current!

Since the leakage current to PE is more than 3.5 mA, in compliance with IEC61800-5-1 the PE connection must either be doubled or a connecting cable with a cross-section > 10 mm² must be used. Deviating measures according to regional standards might be possible.



High voltages!

The equipment produces high electric voltages up to 900V. Do not open or touch the equipment during operation. Keep all covers closed.

During operation, S300 may have uncovered live sections, according to their level of enclosure protection.

Lethal danger exists at live parts of the device. Built-in protection measures such as insulation or shielding may not be removed. Work on the electrical installation may only be performed by trained and qualified personnel, in compliance with the regulations for safety at work, and only with switched off mains supply, and secured against restart.

Never undo any electrical connections to the S300 while it is live. There is a danger of electrical arcing with damage to contacts and personal injury. Wait at least 5 minutes after disconnecting the product from the supply voltages (mains supply and 24V supply) before touching potentially live sections of the equipment (such as contacts) or removing any connections.

Always measure the voltage in the DC bus link and wait until the voltage is below 50 V before handling components.

Functional Safety

The STO safety implementation on the S300 is certified. The assessment of the safety functions according to EN13849 or EN 62061 must finally be done by the user.

Reinforced Insulation

Thermal sensors, motor holding brakes and feedback systems built into the connected motor must have reinforced insulation (according to IEC61800-5-1) against system components with power voltage, according to the required application test voltage. All Kollmorgen components meet these requirements.

Never modify the drive!

It is not allowed to modify the drive hardware without permission by the manufacturer. Opening the housing causes loss of warranty.

3.2 Warning notes placed on the product

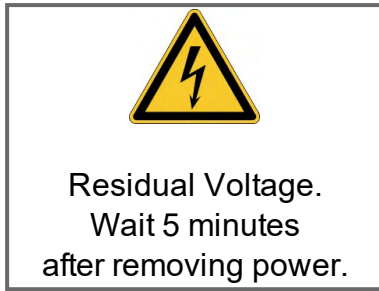

NOTICE

If these signs are damaged, they must be replaced immediately.

3.3 Use as Directed

- The servo amplifiers are components which are built into electrical equipment or machines, and can only be used as integral components of such equipment.
- If the servo amplifiers are used in residential areas, or in business or commercial premises, then additional filter measures must be implemented by the user.

Cabinet and Wiring

- The servo amplifiers **may only** be operated in a closed switchgear cabinet, taking into account the ambient conditions (→ # 29) and the dimensions (→ # 47). Ventilation or cooling may be necessary to prevent enclosure ambient from exceeding 40°C (104°F).
- Use only copper wire. Wire size may be determined from EN 60204 (or table 310-16 of the NEC 60°C or 75°C column for AWG size).

Power supply

- The SERVOSTAR 300 family of servo amplifiers (overvoltage category III acc. to EN 61800-5-1) can be connected directly to symmetrically earthed (grounded) three-phase industrial mains supply networks [TN-system, TT-system with earthed (grounded) neutral point, not more than 42,000 rms symmetrical amperes, 110V_{-10%}...230V^{+10%} respectively 208V_{-10%}...480V^{+10%} maximum]. Connection to different mains supply networks see (→ # 58).
- Periodic overvoltages between outer conductor (L1, L2, L3) and housing of the servo amplifier may not exceed 1000V (peak value). Transient overvoltages (< 50µs) between the outer conductors may not exceed 1000V. Transient overvoltages (< 50µs) between outer conductors and housing may not exceed 2000V.

Motors

- The SERVOSTAR 300 family of servo amplifiers is **only** intended to drive specific brushless synchronous servomotors, with closed-loop control of torque, speed and/or position. The rated voltage of the motors must be at least as high as the DC bus link voltage of the servo amplifier.

Functional Safety

- Consider the specific "use as directed" information (→ # 38) when you use the safety function STO.

3.4 Prohibited Use

Other use than that described in chapter "Use as directed" is not intended and can lead to personnel injuries and equipment damage. The servo amplifier may not be used with a machine that does not comply with appropriate national directives or standards. The use of the servo amplifier in the following environments is also prohibited:

- potentially explosive areas
- environments with corrosive and/or electrically conductive acids, alkaline solutions, oils, vapors, dusts
- ships or offshore applications

The control of holding brakes by the S300 alone may not be used in applications, where functional safety is to be ensured with the brake.

4 Product life cycle handling

4.1 Transport

Transport the SERVOSTAR 300 in accordance with IEC 61800-2 as follows:

- Only by qualified personnel in the manufacturer's original recyclable packaging
- Avoid shocks
- Temperature: -25 to $+70^{\circ}\text{C}$, max. 20K/hr rate of change, class 2K3 acc. to EN61800-2, EN 60721-3-1
- Humidity: max. 95% relative humidity, no condensation, class 2K3 acc. to EN61800-2, EN 60721-3-1
- If the packaging is damaged, check the unit for visible damage. In this case, inform the shipper and the manufacturer.

NOTICE

The servo amplifiers contain electrostatically sensitive components which can be damaged by incorrect handling. Discharge yourself before touching the servo amplifier. Avoid contact with highly insulating materials (artificial fabrics, plastic films etc.). Place the servo amplifier on a conductive surface.

4.2 Packaging

The S300 packaging consists of recyclable cardboard with inserts.

- Dimensions (HxWxD): 115x365x275mm
- Labeling : nameplate outside at the box

4.3 Storage

Store the S300 in accordance with IEC 61800-2 as follows:

- Storage only in the manufacturer's original recyclable packaging
- Max. stacking height 8 cartons
- Storage temperature: -25 to $+55^{\circ}\text{C}$, max. rate of change $20^{\circ}\text{C} / \text{hour}$ class 1K4 acc. to EN61800-2, EN 60721-3-1
- Storage humidity: 5 ... 95% relative humidity, no condensation class 1K3 acc. to EN61800-2, EN 60721-3-1
- Storage duration: Less than 1 year without restriction.

More than 1 year: capacitors must be **re-formed** before setting up and operating the servo amplifier. To do this, remove all electrical connections and apply single-phase 230V AC for about 30 minutes to the terminals L1 / L2.

4.4 Installation, setup and normal operation

In normal operation, the cabinet door must be closed and the device must not be touched. Installation and setup information are given in

- Chapter Mechanical installation (→ # 45)
- Chapter Electrical installation (→ # 48)
- Chapter Setup (→ # 97)

Normal operation tested for environmental class 3K3 according to IEC 61800-2 (→ # 29).

The manufacturer of the machine defines the necessary end user expertise based on the risk assessment for the machine and describes the requirements for normal operation based on the application.

4.5 Decommissioning

NOTICE

Only professional staff who are qualified in electrical engineering are allowed to decommission parts of the system.

DANGER: Lethal Voltages!

There is a danger of serious personal injury or death by electrical shock or electrical arcing.

- Switch off the main switch of the switchgear cabinet.
- Secure the system against restarting.
- Block the main switch.
- Wait at least 5 minutes after disconnecting.

4.6 Maintenance and cleaning

The device does not require maintenance. Opening the device voids the warranty. The inside of the unit can only be cleaned by the manufacturer.

NOTICE

Do not immerse or spray the device. Avoid that liquid enters the device.

To clean the device exterior:

1. Decommission the device (see chapter 4.5 "Decommissioning").
2. Casing: Clean with isopropanol or similar cleaning solution.

Caution : Highly Flammable! Risk of injury by explosion and fire.

- Observe the safety notes given on the cleaning liquid package.
 - Wait at least 30 minutes after cleaning before putting the device back into operation.
3. Protective grill on fan: Clean with a dry brush.

4.7 Disassembly

NOTICE

Only professional staff who are qualified in electrical engineering are allowed to disassemble parts of the system.

1. Decommission the device (see chapter 4.5 "Decommissioning").
2. Check temperature.

CAUTION: High Temperature! Risk of minor burns. During operation, the heat sink of the drive may reach temperatures above 80 °C (176 °F). Before touching the device, check the temperature and wait until it has cooled below 40 °C (104 °F).

3. Remove the connectors. Disconnect the potential earth connection last.
4. Demount: loosen the fastening screws. Remove the device.

4.8 System Repair

NOTICE

Only professional staff who are qualified in electrical engineering are allowed to exchange parts of the drive system.

CAUTION: Automatic Start! During replacement work a combination of hazards and multiple episodes may occur.

- Work on the electrical installation may only be performed by trained and qualified personnel, in compliance with the regulations for safety at work, and only with use of prescribed personal safety equipment.

Exchange of the device

Only the manufacturer can repair the device. Opening the device voids the warranty.

1. Decommission the device (see chapter 4.5 "Decommissioning").
2. Demount the device (see chapter 4.7 "Disassembly").
3. Send the device to the manufacturer.
4. Install a new device as described in this manual.
5. Setup the system as described in this manual.

Exchange of other drive system parts

If parts of the drive system (for example cables) must be replaced, proceed as follows:

1. Decommission the device (see chapter 4.5 "Decommissioning").
2. Exchange the parts.
3. Check all connections for correct fastening.
4. Setup the system as described in this manual.

4.9 Disposal

NOTICE

To dispose the unit properly, contact a certified electronic scrap disposal merchant.

In accordance with the WEEE-2012/19/EU guideline and similar, the manufacturer accepts returns of old devices and accessories for professional disposal. Transport costs are the responsibility of the sender.

Contact Kollmorgen and clarify the logistics.

5 Approvals

Certificates (CE, functional safety) can be found at the [Kollmorgen Website](#).

5.1 Conformance with UL/cUL

This servo amplifier is listed under UL file number **E217428**.

UL (cUL)-certified servo amplifiers (Underwriters Laboratories Inc.) fulfil the relevant U.S. and Canadian standard (in this case UL 840 and UL 508C). The UL certification relates only to the mechanical and electrical construction design of the device.

These standards describe the fulfillment by design of minimum requirements for electrically operated power conversion equipment, such as frequency converters and servo amplifiers, which is intended to eliminate the risk of fire, electric shock, or injury to persons, being caused by such equipment. The technical conformance with the standards is determined by an independent UL inspector through the type testing and regular checkups.

Apart from the notes on installation and safety in the documentation, the customer does not have to observe any other points in direct connection with the UL (cUL)-certification of the equipment.

UL 508C: UL 508C describes the fulfillment by design of minimum requirements for electrically operated power conversion equipment, such as frequency converters and servo amplifiers, which is intended to eliminate the risk of fire being caused by such equipment.

UL 840: UL 840 describes the fulfillment by design of air and insulation creepage spacings for electrical equipment and printed circuit boards.

Markings	Marquages
<ul style="list-style-type: none"> • Use 60°C or 75°C copper wire only. • Use Class 1 wire only. • Tightening torque for field wiring terminals. X0, X8, X9: 0.5 - 0.6Nm (4.43 to 5.31 lbf in). • Use in a pollution degree 2 environment. • These devices provide solid state motor overload protection at 130% of full load current. • Integral solid state short circuit protection does not provide branch circuit protection. Branch circuit protection must be provided in accordance with the National Electrical Code and any additional local codes. • These devices are not provided with motor over-temperature sensing. • Suitable for use on a circuit capable of delivering not more than 42kA rms symmetrical amperes for a max. voltage of 480 Vac. • The drives may be connected together via the "common bus" (DC bus link) based on the instructions on (→ # 61) ff. The devices may also be grouped from the AC input side based on the max. input fuse (e.g. 3xS346 with one common 6A fuse in line). 	<ul style="list-style-type: none"> • Utilisez un fil en cuivre 60°C ou 75 °C min.. • Utilisez seulement un fil de classe 1. • Couples de serrage recommandée. X0, X8, X9: 0.5 - 0.6Nm (4.43 to 5.31 lbf in). • Utilisation dans un environnement de pollution de niveau 2. • Ces variateurs offrent une protection contre les surcharges de moteur à semi-conducteur à 130 % du courant FLA nominal. • Une protection de court-circuit à semi-conducteur intégrale ne fournit pas de protection de la dérivation. Il convient de garantir une protection de la dérivation conforme au NEC (National Electrical Code) et aux réglementations locales en vigueur, ou aux directives équivalentes applicables. • Ces variateurs n'offrent pas de capteurs de température excessive. • Ce produit est conçu pour une utilisation sur un circuit capable de fournir 42 000 ampères symétriques (rms) maximum pour 480V. • Les variateurs peuvent être reliés entre eux via le "bus commun CC" sur la base des instructions (→ # 61) ff. Les variateurs peuvent être groupés d'entrée AC basé sur le max. fusible d'entrée (par exemple 3xS346 avec un fusible de 6A commune).

5.2 Conformance with CE

The servo amplifiers have been tested by an authorized testing laboratory in a defined configuration, using the system components that are described in this documentation. Any divergence from the configuration and installation described in this documentation means that you will be responsible for carrying out new measurements to ensure conformance with regulatory requirements.

Kollmorgen declares the conformity of the products SERVOSTAR 300 (S300) with the following directives

- EC Machinery Directive 2006/42/EU
- EC EMC Directive 2014/30/EU
- EC Low Voltage Directive 2014/35/EU

Concerning noise immunity the servo amplifier meets the requirements to the 2nd environmental category (industrial environment). For noise emission the amplifier meets the requirement to a product of the category C2 (motor cable up to 10 m). With a motor cable length from 10 m onwards, the servo amplifier meets the requirement to the category C3.

NOTICE

This product can cause high-frequency interferences in non industrial environments which can require measures for interference suppression.

5.2.1 European Directives and Standards for the machine builder

Servo amplifiers are safety components that are intended to be incorporated into electrical plant and machines for industrial use. When the servo amplifiers are built into machines or plant, the amplifier must not be used until it has been established that the machine or equipment fulfills the requirements of the

- EC Machinery Directive (2006/42/EU)
- EC EMC Directive (2014/30/EU)
- EC Low Voltage Directive (2014/35/EU)

Standards to be applied for conformance with EC Machinery Directive (2006/42/EU)

- IEC 60204-1 (Safety and Electrical Equipment in Machines)
- ISO 12100 (Safety of Machines)

NOTICE

The manufacturer of the machine must generate a risk assessment for the machine, and must implement appropriate measures to ensure that unforeseen movements cannot cause injury or damage to any person or property.

The machine manufacturer must check whether other standards or EC Directives must be applied to the machine.

Standards to be applied for conformance with the Low Voltage Directive(2014/35/EU)

- IEC 60204-1 (Safety and Electrical Equipment in Machines)
- IEC 60439-1 (Low-voltage switchgear and controller assemblies)

Standards to be applied for conformance with the EMC Directive (2014/30/EU)

- IEC 61000-6-1 / 2 (Interference Immunity in Residential & Industrial Areas)
- IEC 61000-6-3 / 4 (Interference Generation in Residential & Industrial Areas)

The manufacturer of the machine is responsible for ensuring that it meets the limits required by the EMC regulations. Advice on the correct installation for EMC can be found in this documentation.

We only guarantee the conformance of the servo system with the standards cited in this chapter if the components (motor, cables, chokes etc.) are those supplied by us.

5.2.2 Functional Safety Conformance (STO) according to EC Machinery Directive

The S300 servo amplifier offers a single channel STO function (Safe Torque Off) that can be used as a functional safe restart lock.

The safety concept is certified. The safety circuit concept for realizing the safety function "Safe Torque Off" in the servo amplifiers S300 is suited for SIL CL 2 according to IEC 62061 and PLd according to ISO 13849-1.

The subsystems (servo amplifiers) are totally described for safety technics with the characteristic data SIL CL, PFHD and TM.

Device	Operation mode	EN 13849-1	EN 62061	PFHD [1/h]	TM [Year]
STO-Enable	single channel	PLd	SIL CL 2	1.50E-07	20

5.2.3 Conformance with RoHS

The device is manufactured in conformance with RoHS Directive 2011/65/EU with delegated directive 2015/863/EU for installation into a machine.

5.2.4 Conformance with REACH

EU Regulation no. 1907/2006 deals with the registration, evaluation, authorization and restriction of chemical substances 1 (abbreviated to "REACH").

The device does not contain any substances (CMR substances, PBT substances, vPvB substances and similar hazardous substances stipulated in individual cases based on scientific criteria) above 0.1 mass percent per product that are included on the candidate list.

5.3 Conformance with EAC

EAC is the abbreviation for Eurasian Conformity. The mark is used in the states of the Eurasian Customs Union (Russia, Belarus, Kazakhstan) similar to the European CE mark.

Kollmorgen declares, that the device has passed all required conformity procedures in a member state of the Eurasian Customs Union, and that the device meets all technical requirements requested in the member states of the Eurasian Customs Union:

- Low voltage (TP TC 020/2011)
- Electromagnetic Compatibility (TP TC 004/2011)

Contact: SERVOSTAR LLC. , Bld.1, Semyonovskaya nab. 2/1, RU-105094 Moskau

6 Package

6.1 Package Supplied

When you order a SERVOSTAR 300 series amplifier (Order codes (→ # 137)), you will receive:

- S3xx
- Mating connectors X0, X3, X4, X8
- Mating Connector X9 (with SERVOSTAR 303-310 only) (S3xx6)
- S300 Safety Notes printed
- All documentation in PDF format on CD-ROM
- Setup software DRIVE.EXE on CD-ROM

NOTE

The mating SubD connectors are not part of the package!

Accessories: (must be ordered separately; description see accessories manual)

- Hybrid motor cable (prefabricated) for single cable connection
- motor cable (prefabricated) with special shield clamp, or both power connectors separately, with the motor cable as a cut-off length
- feedback cable (prefabricated) or both feedback connectors separately, with the feedback cable as a cut-off length
- motor choke 3YL/3YLN, for motor cables longer than 25 meters
- external brake resistor BAR(U), capacity module KCM
- communication cable to the PC (→ #95) for setting parameters from a PC
- power cable, control cables, fieldbus cables (as cut-off lengths)

6.2 Nameplate

The nameplate is attached to the side of the servo amplifier. The information described below is printed in the individual fields. Picture similar to the original nameplate.

The diagram shows a nameplate with the following fields and callouts:

- Servo amplifier type**: Points to the 'Typenbezeichnung' field.
- Serial number**: Points to the 'Ser. Nr' field.
- Comments**: Points to the 'Ser. No.' field.
- Output current in S1 operation**: Points to the 'Output' field.
- max. surrounding air temperature**: Points to the 'Umgebungstemp. / Surrounding temp.' field.
- Electrical supply Installed load**: Points to the 'Schutzart' field.
- Enclosure rating**: Points to the 'Encl.Rating' field.
- Hardware Revision**: Points to the 'Hardware Revision' field.

The nameplate itself contains the following information:

Kollmorgen Europe GmbH
 Pempelfurtstraße 1
 D-40880 Ratingen
 www.kollmorgen.com

Customer Support
 Europe Tel. +49 (0)2102 / 93940
 Italy Tel. +39 (0)362 / 594260
 North America Tel. +1 540 633 3545

EAC E217428 C UL US LISTED IND. CONT. EQ. 1VD4 CE

Typenbezeichnung Model Number Ser. Nr Ser. No. Series SERVOSTAR 300

Eingang Input Ausgang Output

Umgebungstemp. Surrounding temp. Hardware Revision

RoHS conform Schutzart Encl.Rating

example example

6.3 Part Number Scheme

Use the part number scheme for product identification only, not for the order process, because not all combinations of features are possible, always.

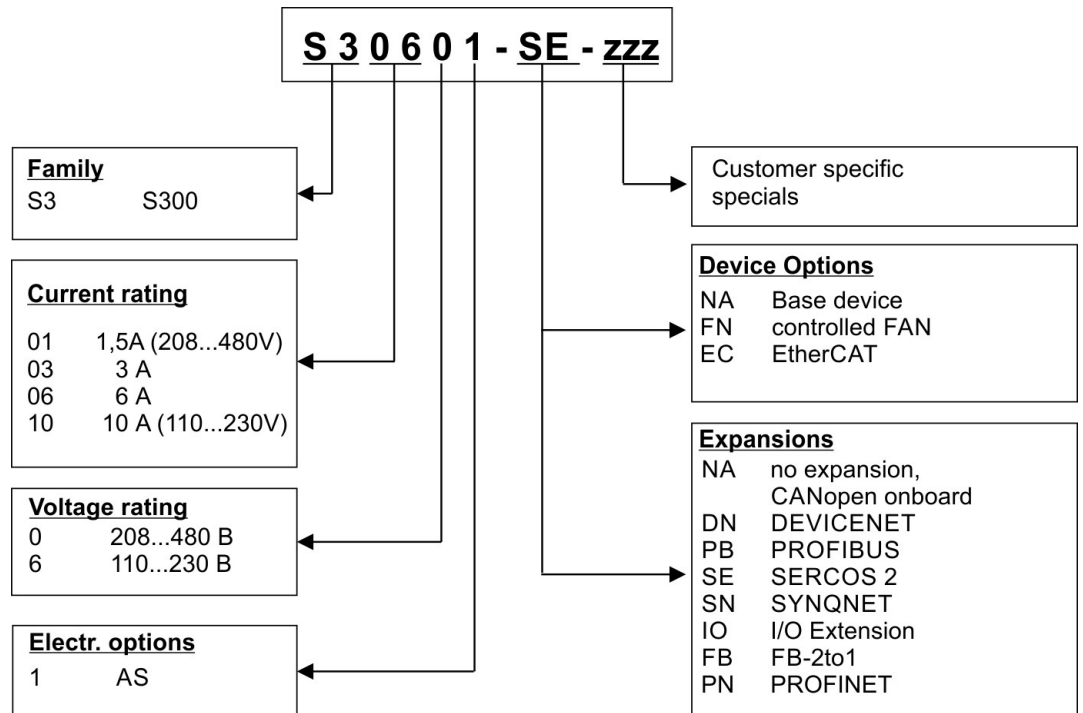

NOTE

Expansions and device options cannot be combined.

Comparison device name -> part number

Device Name	Part Number
SERVOSTAR 303	S30361-NA
SERVOSTAR 306	S30661-NA
SERVOSTAR 310	S31061-NA
SERVOSTAR 341	S30101-NA
SERVOSTAR 343	S30301-NA
SERVOSTAR 346	S30601-NA

7 Technical description

7.1 The SERVOSTAR 300 family of digital servo amplifiers

Standard version

- Two voltage classes with large nominal voltage range
1 x 110 V_{-10%} ... 3 x 230 V^{+10%} (SERVOSTAR 303-310, S3xx6)
3 x 208 V_{-10%} ... 3 x 480 V^{+10%} (SERVOSTAR 341-346, S3xx0)
- Overvoltage category III acc. to EN 61800-5-1
- Shielding connection directly on the servo amplifier
- Two analog inputs onboard
- CANopen onboard (default: 500 kBaud), for integration in CAN-bus systems and for setting parameters for several drives via the PC interface of one of the amplifiers
- Slot for an expansion card
- RS232 and pulse direction interface onboard
- Restart lock STO for functional safety onboard (→ # 38)
- Intelligent position controller onboard
- Multi feedback support
- Synchronous servomotors, linear motors, asynchronous motors, high frequency spindles and DC motors can be used

Power section

- Directly on grounded 3-phase supply, 110V_{-10%} or 230V_{-10%} up to 480V^{+10%}
TN-network or TT-network with grounded neutral point, 42kA max. symmetrical current rating, connection to other supply types only via isolating transformer, (→ # 58)
- B6 bridge rectifier, integral supply filter and soft-start circuit
- Single-phase supply operation possible (e.g. for setup)
- Fusing: (e.g. fusible cutout) to be provided by the user
- Shielding: all shielding connections are made directly on the amplifier
- Output stage: IGBT module with floating current measurement
- Brake circuit with dynamic distribution of the regenerated power between several amplifiers on the same DC bus link circuit. Internal brake resistor as standard, external brake resistors if required.
- DC bus link voltage 135 ... 450 V DC or 260 ... 900 V DC, can be connected in parallel.
- Interference suppression filters are integrated for the electrical supply feed and the 24V auxiliary supply voltage (with motor cable 10m for C2 as per EN 61800-3, with motor cable > 10m for C3 as per EN 61800-3).

Integrated safety

- Appropriate insulation/creepage distances and electrical isolation ensure safe electrical separation, as per EN 61800-5-1, between the power input / motor connections and the signal electronics.
- Soft-start, overvoltage detection, short-circuit protection, phase-failure monitoring.
- Temperature monitoring of the servo amplifier and motor (if our motors and prefabricated cables are used).

Auxiliary supply voltage 24V DC

- Electrically isolated, internal fusing, from an external 24V DC power supply unit with, for instance, isolating transformer or uninterruptible power supply.

Operation and parameter setting

- With our user-friendly setup software, for setup via the serial interface of a PC.
- If no PC is available: direct operation by two keys on the servo amplifier and a 3-character LED display.
- Fully programmable via RS232 interface.

Completely digital control

- Digital current controller (space vector, pulse-width modulation, 62.5 μ s)
- Adjustable digital speed controller (62.5 μ s)
- Integrated position controller, with adaptation possibilities for all applications (250 μ s)
- Integrated step/direction interface for connecting a servomotor to a stepper controller
- Evaluation of resolver signals and sine-cosine signals of high-resolution encoders
- Encoder emulation (incremental, compatible with A quad B or SSI)

Comfort functions

- 2 programmable analog inputs
- 4 programmable digital inputs
- 2 programmable digital outputs
- programmable logical combinations of digital signals

Device Options

- Option EtherCAT, cannot be inserted later, (→ # 133)
- Option FAN, ventilator control, cannot be inserted later, (→ # 134)

Expansions

- I/O-14/08 expansion card,, (→ # 116)
- PROFIBUS DP expansion card,, (→ # 119)
- sercos® II expansion card,, (→ # 120)
- DeviceNet expansion card,, (→ # 122)
- SynqNet expansion card,, (→ # 125)
- FB-2to1 expansion card,, (→ # 127)
- PROFINET expansion card, (→ # 129)
- -2CAN- expansion module, separated connectors for CAN-bus and RS232, (→ # 131)
- Several third-party expansion cards (ModBus, LightBus, FIP-IO etc. please contact the manufacturer for further information)

7.2 Technical Data

7.2.1 Technical Data 110 / 230 V (Types S3_6_)

Rated data	DIM	S303	S306	S310
Order code	-	S30361	S30661	S31061
Rated supply voltage (L1,L2,L3) (grounded system, phase-phase)	V~	1 x 110V _{-10%} ... 230V ^{+10%} , 50/60 Hz 3 x 110V _{-10%} ... 230V ^{+10%} , 50/60 Hz		
Rated installed load for continuous operation at 230V	kVA	1.1	2.4	4
Permitted switch on/off frequency	1/h	30		
Max DC bus link voltage	V=	450		
Rated output current (rms value, ± 3%)				
at 1x115V (observe (→ # 60))	Arms	3.5*	8*	10*
at 1x230V (observe (→ # 60))	Arms	3*	6*	10*
at 3x115V	Arms	3.5	8	10
at 3x230V	Arms	3	6	10
Peak output current (max. ca. 5s, ± 3%)				
at 1x115V, 1x230V (observe (→ # 60))	Arms	9*	15*	20*
at 3x115V, 3x230V	Arms	9	15	20
Clock frequency of the output stage	kHz	8 / 16 with 50% derating		
Voltage rise speed dU/dt (observe notes on page (→ # 64))				
at 1x115V	kV/μs	3.0		
at 1x230V	kV/μs	3.3		
at 3x115V	kV/μs	3.0		
at 3x230V	kV/μs	3.3		
Technical data for brake circuit	-	(→ # 31)		
Overvoltage protection threshold at 115 V / 230 V	V	235 / 455		
Motor inductance min.				
at 1x115V	mH	3.7	3.7	3.7
at 1x230V	mH	4.3	4.3	4.3
at 3x115V	mH	2.1	1.3	1.0
at 3x230V	mH	4.3	2.6	1.9
Motor inductance max.	mH	Consult our customer support		
Form factor of the output current (rated conditions, min. load inductance)	-	1.01		
Bandwidth of subordinate current controller	kHz	> 1.2		
Residual voltage drop at rated current	V	4		
Quiescent dissipation, output stage disabled	W	12		
Dissipation at rated current (incl. power supply losses, without brake dissipation)	W	35	60	90
Noise emission max.	dB(A)	25	45	
Mechanical				
Weight	kg	2.7		
Height without connectors	mm	270	279	
Width	mm	70		
Depth without/with connectors	mm	171 / <200		

*in single-phase applications nom./peak current is limited to value below nominal value.

This depends on motor constant Kt and motor speed (→ # 60).

7.2.2 Technical Data 230V ... 480 V (types S3_ _0_)

Rated data	DIM	S341	S343	S346
Order code	-	S30101	S30301	S30601
Rated supply voltage (L1,L2,L3) (grounded system, phase-phase)	V~	3 x 208V _{-10%} ... 480V ^{+10%} , 50/60 Hz		
Rated installed load for continuous operation at 400V	kVA	1.2	2.5	5
Permitted switch on/off frequency	1/h	30		
Max DC bus link voltage	V=	900		
Rated output current (rms value, ± 3%)				
at 3x208V	Arms	2	5	6
at 3x230V	Arms	2	5	6
at 3x400V	Arms	1.5	4	6
at 3x480V	Arms	1.5	3	6
Peak output current (max. ca. 5s, ± 3%)				
at 3x208V...3x480V	Arms	4.5	7.5	12
Clock frequency of the output stage	kHz	8 / 16 with 50% derating		
Voltage rise speed dU/dt (observe notes on page (→ # 64))				
at 3x208V	kV/μs	3.0		
at 3x230V	kV/μs	3.3		
at 3x400V	kV/μs	5.7		
at 3x480V	kV/μs	6.9		
Technical data for brake circuit	-	(→ # 31)		
Overvoltage protection threshold				
at 3x230V	V	455		
at 3x400V	V	800		
at 3x480V	V	900		
Motor inductance min.				
at 3x208V	mH	7.7	4.6	2.9
at 3x230V	mH	8.5	5.1	3.2
at 3x400V	mH	14.8	8.9	5.6
at 3x480V	mH	17.8	10.7	6.7
Motor inductance max.	mH	Consult our customer support		
Form factor of the output current (rated conditions, min. load inductance)	-	1.01		
Bandwidth of subordinate current controller	kHz	> 1.2		
Residual voltage drop at rated current	V	5		
Quiescent dissipation, output stage disabled	W	12		
Dissipation at rated current (incl. power supply losses, without brake dissipation)	W	40	60	90
Noise emission max.	dB(A)	25	45	
Mechanical				
Weight	kg	2.7		
Height without connectors	mm	270	279	
Width	mm	70		
Depth without/with connectors	mm	171 / <230		

7.2.3 Inputs / outputs, Auxiliary voltage

Interface	Electr. data
Analog inputs 1, 2 (resolution 14/12 bit)	±10V
Max. common-mode voltage	±10V
Digital control inputs	as per EN 61131-2 type1, max. 30VDC
Digital control outputs, active high	open Emitter, max. 30VDC, 10mA
BTB/RTO output, relay contacts	max. 30VDC, max 42VAC
	500mA
Auxiliary supply voltage, electrically isolated, without motor brake / fan	20V - 30V
	1A
Auxiliary supply voltage, electrically isolated, with motor brake / fan	24V (-0% +15%)
	2.5A (check voltage drop !)
Min./max. output current to brake	0.15A / 1.5A

7.2.4 Connectors

Connector	Type	max. cross section ^{*1}	permitted current ^{*2}	permitted tension ^{*3}
Control signals X3, X4	Mini-Combicon	1.5 mm ²	4 A	160 V
S303-310: Power X0,X8,X9	Classic-Combicon	2.5 mm ²	12 A	630V
S341-346: Power X0, X8, X9	Power-Combicon	4 mm ²	16 A	1000 V
Resolver input X2	SubD 9pin (female)	0.5 mm ²	1 A	<100 V
Encoder input X1	SubD 15pin (female)	0.5 mm ²	1 A	<100 V
PC interface, CAN X6	SubD 9pin (male)	0.5 mm ²	1 A	<100 V
Encoder emulation X5	SubD 9pin (male)	0.5 mm ²	1 A	<100 V

*1 single-line connection

*2 single-line connection with recommended conductor cross section (→ # 29)

*3 rated voltage with pollution level 2

7.2.5 Recommended Tightening Torques

Connector	Recommended torque
X0, X8, X9	0.5 to 0.6 Nm (4.43 to 5.31 in lbf)
Ground bolt	3.5 Nm (31 in lbf)

7.2.6 Fusing

Internal Fusing

Circuit	internal fuse
Auxiliary supply 24V	3.15 A
Brake resistor	electronic

External fusing

Fusible cutouts or similar	S303 / S341 / S343	S306 / S310 / S346
AC supply $F_{N1/2/3}$	6 A	10 A
24V supply $F_{H1/2/3}$	max. 8 A	
Brake resistor $F_{B1/2}$	6 A*	6 A*

European fuses: gRL or gL 400V/500V, T means time-delay,

US fuses: class RK5/CC/J/T, 600VAC 200kA, time-delay

* for example Bussmann FWP-xx

7.2.7 Ambient Conditions, Ventilation and Mounting Position

Storage, hints	(→ # 16)
Transport, hints	(→ # 16)
Mains power supply	S303-S310: 1x110V-10% ... 1x230V+10%, 50/60 Hz 3x110V-10% ... 3x230V+10%, 50/60 Hz S341-S346: 3x208V-10% ... 3x 480V+10%, 50/60 Hz
Aux. power supply without brake and fan with brake or fan	20 V DC ... 30 V DC 24 V DC (-0% +15%), check voltage drop
Surrounding air temperature in operation	0 to +40°C (32 to 104°F) at rated data +40 to +55°C (113 to 131°F) with power derating 2.5% / K
Humidity in operation	rel. humidity 85%, no condensation, class 3K3
Site altitude	up to 1000m a.m.s.l. without restriction 1000 — 2500m a.m.s.l. with power derating 1.5%/100m
Pollution level	Pollution level 2 to EN 60664-1
Vibrations	Class 3M2 according to IEC 60721-3-3
Enclosure protection	IP 20 according to EN60529
Mounting position	generally vertical (→ # 46)
Ventilation S303 und S341 all other types	natural convection built-on fan (optionally controlled, Option FN (→ # 134))
NOTICE	Make sure that there is sufficient forced ventilation within the switchgear cabinet.

7.2.8 Conductor cross-sections

Recommendations for cables (material and construction (→ # 52)):

Interface	Cross section	Techn. Requirements
ACconnection	1.5 mm ²	600V, 80°C
DDC bus link Brake resistor	2.5 mm ²	1000V, 80°C, shielded for lengths >0.20m
Motor cables up to 25m, motor choke	1..1.5 mm ² , max. 25 m	600V, 80°C, shielded, capacitance <150pF/m
Motor cables 25m to 50 m, motor choke 3YL/3YLN	1 mm ² , 25 - 50m*	600V, 80°C, shielded, capacitance <150pF/m
Resolver, motor thermal control	4x2x0.25 mm ² , max. 100m*	twisted pairs, shielded, capacitance <120pF/m
Encoder, motor thermal control	7x2x0.25 mm ² , max. 50m*	twisted pairs, shielded
ComCoder, motor thermal control	8x2x0.25 mm ² , max. 25m	twisted pairs, shielded
Setpoints, AGND	0.25 mm ² , max. 30m	twisted pairs, shielded
Control signals, BTB, DGND	0.5 mm ² , max. 30m	
Holding brake (motor)	min. 0.75 mm ²	600V, 80°C, shielded, check voltage drop
+24 V / DGND	max. 2.5 mm ²	check voltage drop
NOTICE	For multi-axis systems, observe the specific operating conditions for your system. To reach the max. permitted cable length, observe cable requirements (→ # 52).	

* Kollmorgen North America supplies cables up to 39 meters, Europe up to max. length

7.3 Motor holding brake

A 24V / max. 1.5A holding brake in the motor can be controlled directly by the amplifier.



CAUTION No functional safety!

Danger by falling load (in case of suspended load, vertical axes). An additional mechanical brake is required for functional safety, which must be safely operated.

NOTICE

The brake only works with sufficient voltage level (→ # 28). Check voltage drop, measure the voltage at brake input and check brake function (brake and no brake).

The brake function must be enabled through the BRAKE setting (screen page: Motor). In the diagram below you can see the timing and functional relationships between the ENABLE signal, speed setpoint, speed and braking force. All values can be adjusted with parameters, the values in the diagram are default values.

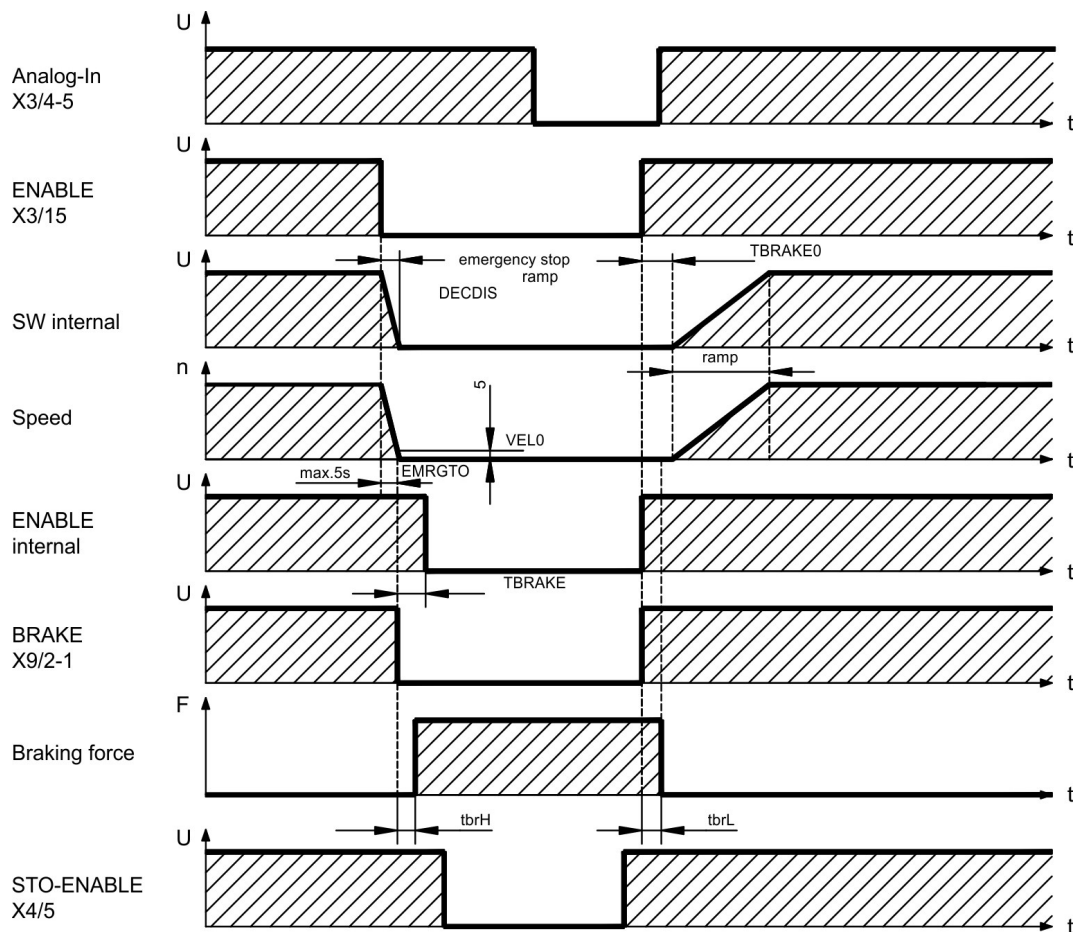

During the internal ENABLE delay time of 100ms (DECDIS), the speed setpoint of the servo amplifier is internally driven down an adjustable ramp to 0V. The output for the brake is switched on when the speed has reached 5 rpm (VELO), at the latest after 5 seconds (EMRGTO).

The release delay time (tbrH) and the engage delay time (tbrL) of the holding brake that is built into the motor are different for the various types of motor (see motor manual), the matching data are loaded from the motor database when the motor is selected.

A description of the interface can be found on page (→ # 64).

7.4 LED display

A 3-character [LED-Display](#) indicates the status of the amplifier after switching on the 24 V supply (→ # 110). When the keys on the front panel are used, the parameter and function numbers are shown, as well as the numbers for any errors and warnings that may occur (→ # 112).

7.5 Grounding system

AGND - analog inputs, internal analog ground, Encoder emulation, RS232, CAN
 DGND - 24V-IO, digital inputs and digital outputs, optically isolated

7.6 Dynamic braking (brake circuit)

During dynamic braking with the aid of the motor, energy is fed back into the servo amplifier. This regenerative energy is dissipated as heat in the brake resistor. The brake resistor is switched in by the brake circuit.

The setup software can be used to adapt the brake circuit (thresholds) according to the electrical supply voltage.

Our customer service can help you with the calculation of the brake power that is necessary for your system. A [simple method](#) is described in the "KDN".

A description of the interface can be found on page (→ # 61).

Functional description:

1. Individual amplifiers, not coupled through the DC bus link circuit (DC+, DC-)

When the energy fed back from the motor has an average or peak power that exceeds the preset level for the brake power rating, then the servo amplifier generates the warning "n02 brake power exceeded" and the brake circuit is switched off.

The next internal check of the DC bus link voltage (after a few milliseconds) detects an overvoltage and the output stage is switched off, with the error message "Overvoltage F02" (→ # 112).

The BTB/RTO contact (terminals X3/2,3) will be opened at the same time (→ # 94).

2. Several servo amplifiers coupled through the DC bus link (DC+, DC-)

Using the built-in brake circuit, several amplifiers (even with different current ratings) can be operated off a common DC bus link, without requiring any additional measures.

The combined (peak and continuous) power of all amplifiers is always available. The switch-off on overvoltage takes place as described under 1. (above) for the amplifier that has the lowest switch-off threshold (resulting from tolerances).

Technical data of the brake circuits dependent on the amplifiers type and the mains voltage situation see table on the next page.

Technical Data:

Type	Brake circuit Rated data	DIM	Supply voltage / V			
			115	230	400	480
S303 (S30361)	Switch-on (upper) threshold of brake circuit	V	200	400	—	
	Overvoltage F02	V	235	455	—	
	Internal brake resistor (RBint)	Ohm	66	66	—	
	Continuous power for internal resistor (RBint)	W	20	20	—	
	Max. brake power (average for 1s)	kW	0,4	0,35	—	
	Pulse brake power	kW	0,84	3	—	
	External brake resistor (RBext), optional	Ohm	66	66	—	
	Continuous power for external resistor (RBext)	kW	0,3	0,3	—	
S306 (S30661) S310 (S31061)	Switch-on (upper) threshold of brake circuit	V	200	400	—	
	Overvoltage F02	V	235	455	—	
	Internal brake resistor (RBint)	Ohm	66	66	—	
	Continuous power for internal resistor (RBint)	W	50	50	—	
	Max. brake power (average for 1s)	kW	0,84	0,88	—	
	Pulse brake power	kW	0,84	3	—	
	External brake resistor (RBext), optional	Ohm	66	66	—	
	Continuous power for external resistor (RBext)	kW	1	1	—	
S341 (S30101)	Switch-on (upper) threshold of brake circuit	V	—	400	720	840
	Overvoltage F02	V		455	800	900
	Internal brake resistor (RBint)	Ohm		91	91	91
	Continuous power for internal resistor (RBint)	W		20	20	20
	Max. brake power (average for 1s)	kW		0,35	0,33	0,34
	Pulse brake power	kW		2,1	7	9
	External brake resistor (RBext), optional	Ohm		91	91	91
	Continuous power for external resistor (RBext)	kW		0,3	0,3	0,3
S343 (S30301) S346 (S30601)	Switch-on (upper) threshold of brake circuit	V	—	400	720	840
	Overvoltage F02	V		455	800	900
	Internal brake resistor (RBint)	Ohm		91	91	91
	Continuous power for internal resistor (RBint)	W		50	50	50
	Max. brake power (average for 1s)	kW		0,91	0,86	0,85
	Pulse brake power	kW		2,1	7	9
	External brake resistor (RBext), optional	Ohm		91	91	91
	Continuous power for external resistor (RBext)	kW		1,0	1,0	1,0

NOTE

Suitable external brake resistors can be found in our accessories manual.

7.7 Switch-on and switch-off behavior

This chapter describes the switch-on and switch-off behavior of the S700 and the steps required to achieve operational stopping or emergency stop behavior that complies with standards.

NOTE

The servo amplifier's 24 V supply must remain constant.

The ASCII commands [ACTFAULT](#) (error response, also depends on the specific error, see [ERRCODE](#)) and [STOPMODE](#) (Enable signal response) dictate how the drive will behave.

ACTFAULT & STOPMODE	Behavior: (see also ASCII reference in the Online Help of the setup software)
0	Motor coasts to a standstill in an uncontrolled manner
1 (default)	Motor is braked in a controlled manner

Behavior during a power failure

The servo amplifiers use an integrated circuit to detect if one or more input phases (power supply feed) fail. The behavior of the servo amplifier is set using the setup software: Under "**Response to Loss of Input Phase**" ([PMODE](#)) on the **Basic Setup** screen, select: Error message if the servo amplifier is to bring the drive to a standstill: Error message F19 is output if an input phase is missing. The servo amplifier is disabled and the BTB contact opens. Where the factory setting is unchanged ([ACTFAULT](#)=1), the motor is braked using the set "EMERGENCY STOP RAMP".

- **Warning** if the higher-level control system is to bring the drive to a standstill: Warning n05 is output if an input phase is missing, and the motor current is limited to 4 A. The servo amplifier is not disabled. The higher-level control system can now selectively end the current cycle or start bringing the drive to a standstill. Therefore, the error message "MAINS BTB, F16" is output on a digital
- **Error message** if the servo amplifier is to bring the drive to a standstill: Error message F19 is output if an input phase is missing. The servo amplifier is disabled and the BTB contact opens. Where the factory setting is unchanged ([ACTFAULT](#)=1), the motor is braked using the set "EMERGENCY STOP RAMP".

Behavior when undervoltage threshold is reached

If the undervoltage threshold is undershot in the DC bus link (the threshold value depends on the type of servo amplifier), the error message "UNDERVOLTAGE, F05" is displayed. The drive response depends on the [ACTFAULT](#) and [STOPMODE](#) setting.

Behavior with enabled "holding brake" function

Servo amplifiers with an enabled holding brake function have a special procedure for switching off the output stage (→ # 30). Removing the ENABLE signal triggers electrical braking. As with all electronic circuits, the general rule applies that there is a possibility of the internal "holding brake" module failing. Functional safety, e.g. with hanging load (vertical axes), requires an additional mechanical brake which must be safely operated.

Behavior of the safety function STO

With the functional safe restart lock STO, the drive can be secured on standstill using its internal electronics so that even when power is being supplied, the drive shaft is protected against unintentional restart. The chapter "Safety function STO" describes how to use the STO function. See (→ # 38) onwards.

7.7.1 Behavior in standard operation

The behavior of the servo amplifier always depends on the current setting of a number of different parameters (e.g., ACTFAULT, VBUSMIN, VELO, STOPMODE, see [Online Help](#)).

The diagram below illustrates the correct functional sequence for switching the servo amplifier on and off.

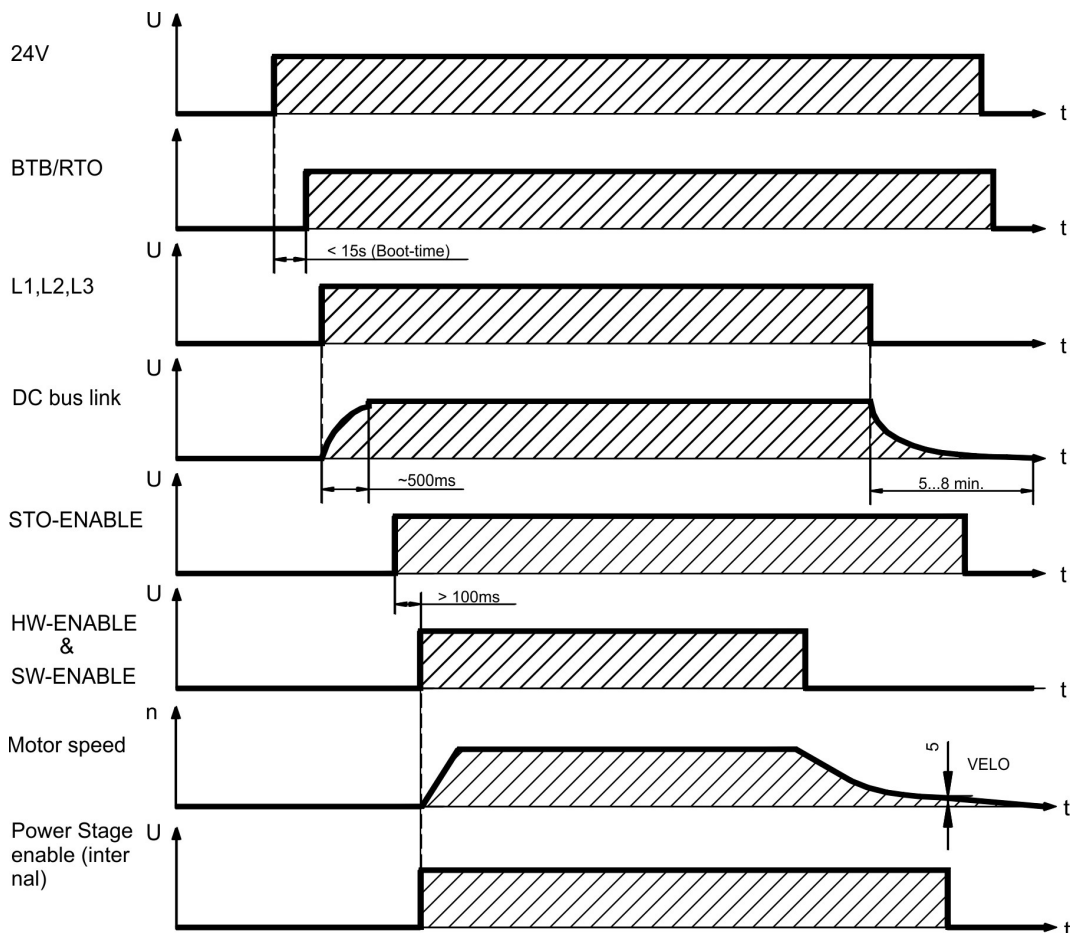

Devices which are equipped with a selected "Brake" function use a special sequence for switching off the output stage (→ # 30).

The built-in safety function STO can be used to switch off the drive, so that functional safety is ensured at the drive shaft (→ # 38).

7.7.2 Behavior in the event of an error (with standard setting)

The behavior of the servo amplifier always depends on the current setting of a number of different parameters (e.g., ACTFAULT, VBUSMIN, VELO, STOPMODE, see [Online Help](#)).



CAUTION Uncontrolled coasting!

Some faults (see [ERRCODE](#)) force the output stage to switch-off immediately, independent from the [ACTFAULT](#) setting. Danger of injury by uncontrolled coasting of the load. An additional mechanical brake is required for functional safety, which must be safely operated.

The diagram shows the startup procedure and the procedure that the internal control system follows in the event of motor overtemperature, assuming that the standard parameter settings apply. Fault F06 does not switch-off the output stage immediately, with ACTFAULT=1 a controlled emergency brake is started first.

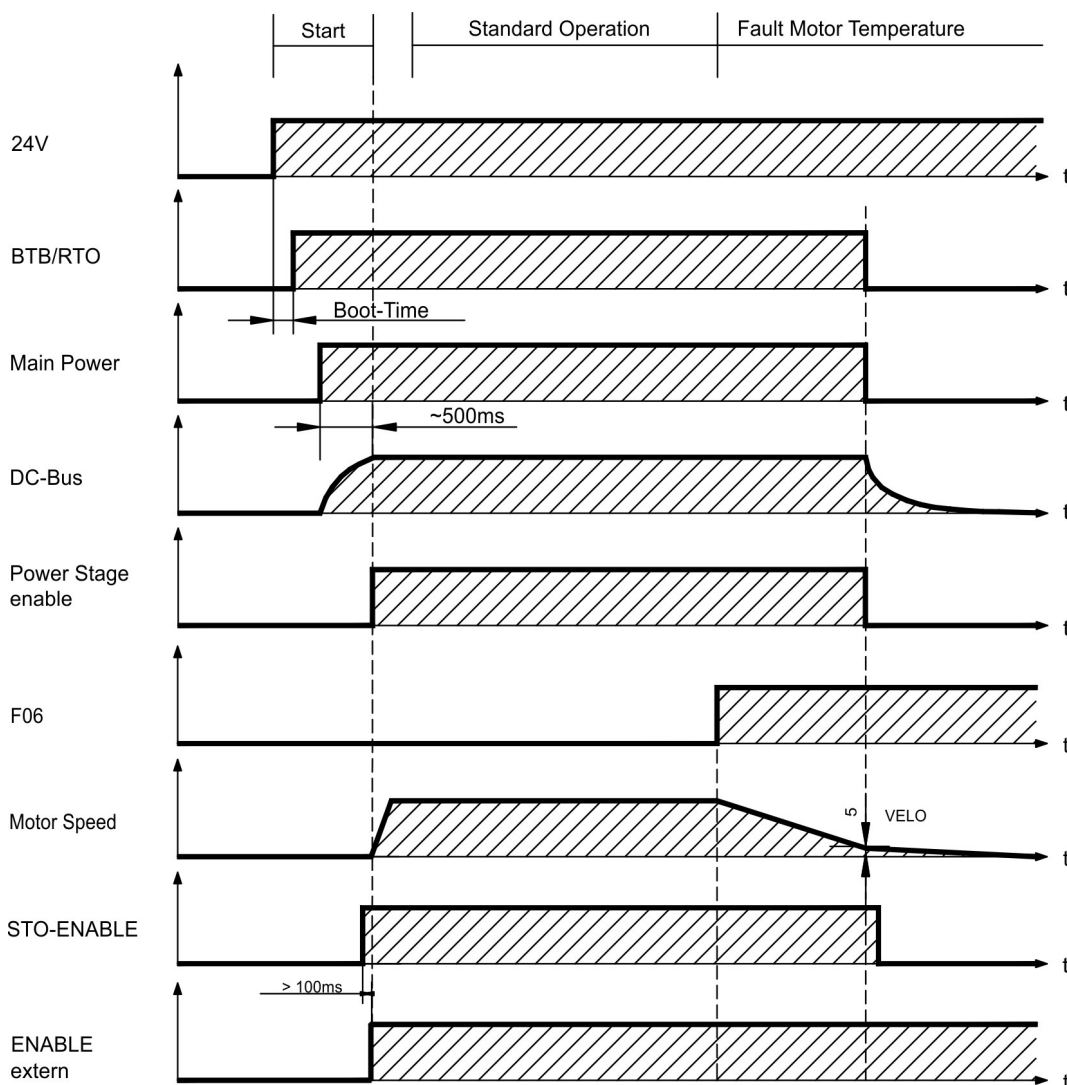

(F06 = error messages "Motor Temperature")

Even if there is no intervention from an external control system (in the example, the ENABLE signal remains active), the motor is immediately braked using the emergency stop ramp if the error is detected and assuming that no changes have been made to the factory setting (ACTFAULT=1).

7.8 Stop-, Emergency Stop-, Emergency Off Function to IEC 60204

With the functional safe, certified function STO (→ # 38) the drive can be secured on stand-still (torque-free) using its internal electronics so that even when power is being supplied, the drive shaft is protected against unintentional restart (up to SIL CL3 according to IEC 62061, PLe according to ISO 13849-1).

The parameters “STOPMODE” and “ACTFAULT” must be set to 1 in order to implement the stop and emergency stop categories. If necessary, change the parameters via the terminal screen of the setup software and store the data in the EEPROM.

Examples for implementation can be found in the KDN on page [Stop and Emergency Stop Function](#).

7.8.1 Stop

The Stop function is used to shut down the machine in normal operation. The Stop functions are defined by IEC 60204.

- Category 0:** Shut-down by immediate switching-off of the energy supply to the drive machinery (i.e. an uncontrolled shut-down); this can be done with the built-in STO functionality (→ # 38) .
- Category 1:** A controlled shut-down , whereby the energy supply to the drive machinery is maintained to perform the shut-down, and the energy supply is only interrupted when the shut-down has been completed;
- Category 2:** A controlled shut-down, whereby the energy supply to the drive machinery is maintained.

The Stop Category must be determined by a risk evaluation of the machine. In addition, suitable means must be provided to guarantee a reliable shut-down.

Category 0 and Category 1 Stops must be operable independently of the operating mode, whereby a Category 0 Stop must have priority. Stop functions must be implemented by disconnection of the appropriate circuitry, and have priority over assigned start functions.

If necessary, provision must be made for the connection of protective devices and lock-outs. If applicable, the Stop function must signal its status to the control logic. A reset of the Stop function must not create a hazardous situation.

Examples for implementation can be found in the KDN on page [Stop and Emergency Stop Function](#).

7.8.2 Emergency Stop

The Emergency Stop function is used for the **fastest possible shutdown** of the machine in a dangerous situation. The Emergency Stop function is defined by IEC 60204. Principles of emergency stop devices and functional aspects are defined in ISO 13850.

The Emergency Stop function will be triggered by the manual actions of a single person. It must be fully functional and available at all times. The user must understand instantly how to operate this mechanism (without consulting references or instructions).

NOTE

The Stop Category for the Emergency Stop must be determined by a risk evaluation of the machine.

In addition to the requirements for stop, the Emergency Stop must fulfil the following requirements:

- Emergency Stop must have priority over all other functions and controls in all operating modes.
- The energy supply to any drive machinery that could cause dangerous situations must be switched off as fast as possible, without causing any further hazards (Stop Category 0) or must be controlled in such a way, that any movement that causes danger, is stopped as fast as possible (Stop Category 1).
- The reset must not initiate a restart.

Examples for implementation can be found in the KDN on page [Stop and Emergency Stop Function](#).

7.8.3 Emergency Off

The Emergency Off function is used to switch-off the electrical power supply of the machine. This is done to prevent users from any risk from electrical energy (for example electrical impact). Functional aspects for Emergency Off are defined in IEC 60364-5-53.

The Emergency Off function will be triggered by the manual actions of a single person.

NOTE

The result of a risk evaluation of the machine determines the necessity for an Emergency Off function.

Emergency Off is done by switching off the supply energy by electro-mechanical switching devices. This results in a category 0 stop. If this stop category is not possible in the application, then the Emergency Off function must be replaced by other measures (for example by protection against direct touching).

7.9 Safe Torque Off (STO)

A frequently required application task is the protection of personnel against the restarting of drives. The S300 servo amplifier offers, even in the basic version, a single channel STO function (Safe Torque Off) that can be used as a functional safe restart lock.

Advantages of the restart lock STO :

- the DC bus link remains charged up, since the mains supply line remains active ,
- only low voltages are switched, so there is no contact wear ,
- the wiring effort is very low.

The safety function STO can be operated from a safe external control (semiconductor output or driven contact).

The safety concept is certified. The safety circuit concept for realizing the safety function "Safe Torque Off" in the servo amplifiers S300 is suited for SIL CL 2 according to IEC 62061 and PLd according to ISO 13849-1.

7.9.1 Safety characteristic data

The subsystems (servo amplifiers) are totally described for safety technics with the characteristic data SIL CL, PFHD and TM.

Device	Operation Mode	EN 13849-1	EN 62061	PFH [1/h]	T _M [Years]	SFF [%]
STO-Enable	single channel	PL d, Cat. 3	SIL CL 2	1,50E-07	20	100

7.9.2 Safety Notes



⚠ WARNING High electrical voltage!

Risk of electric shock! The function STO does not provide an electrical separation from the power output. If access to the motor power terminals is necessary,

- disconnect the servo amplifier from mains supply,
- consider the discharging time of the intermediate circuit.



⚠ WARNING No Brake Power!

Serious injury could result when a suspended load is not properly blocked. The servo amplifier cannot hold a vertical load when STO is active.

- Add a safe mechanical blocking (for instance, a motor-holding brake).



⚠ CAUTION Uncontrolled movement!

Danger of personal injury. If STO is engaged during operation by separating input STO1-Enable and STO2-Enable from 24 VDC, the motor runs down out of control and the servo amplifier displays the error F27. There is no possibility of braking the drive controlled.

- Brake the drive in a controlled way first and then separate the STO inputs from +24VDC time-delayed.

NOTICE

If the STO is automatically activated by a control system, then make sure that the output of the control is supervised for possible malfunction. This can be used to prevent a faulty output from unintentionally activating the function STO. Since STO is used in a single-channel system, erroneous engaging will not be recognized.

NOTICE

Controlled braking:

Keep to the following functional sequence when the drive must be braked in a controlled manner:

1. Brake the drive in a controlled manner (velocity setpoint = 0V)
2. When speed = 0 rpm, disable the servo amplifier (enable = 0V)
3. If there is a suspended load, block the drive mechanically
4. Activate STO.

7.9.3 Use as directed

The STO function is exclusively intended to provide functional safety, by preventing the restart of a system. To achieve this functional safety, the wiring of the safety circuits must meet the safety requirements of IEC60204, ISO12100, IEC62061 SIL CL2 respectively ISO13849-1 PLd.

If STO is automatically activated by a control system, then make sure that the output of the control is monitored for possible malfunction.

7.9.4 Prohibited Use STO

The STO function must not be used if the drive is to be made inactive for the following reasons :

- Cleaning, maintenance and repair operations, long inoperative periods:
In such cases, the entire system should be disconnected from the supply by the personnel, and secured (main switch).
- Emergency-Off situations: the mains contactor must be switched off (by the emergency-Off button).

7.9.5 Technical data and pinning

Input voltage	20 V..30 V
Input current	33 mA – 40 mA (Ieff)
Peak current	100 mA (Is)
Response time (falling edge at STO input until energy supply to motor is interrupted)	1 ms

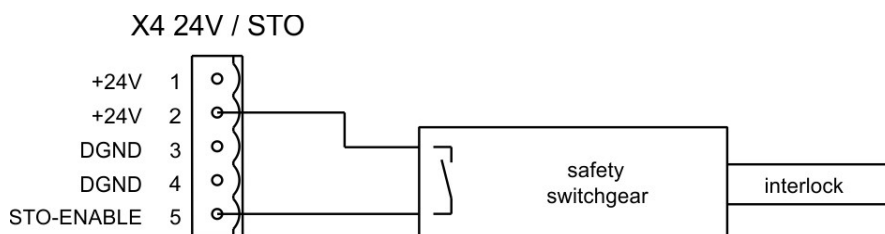

7.9.6 Enclosure

Since the servo amplifier meets enclosure IP20, you must select the enclosure ensuring a safe operation of the servo amplifier referring to the enclosure. The enclosure must meet IP54 at least.

7.9.7 Wiring

When using STO wiring leads outside the control cabinet, the cables must be laid durably (firmly), protected from outside damage (e.g. laying in a cable duct), in different sheathed cables or protected individually by grounding connection.

Wiring remaining within the demanded enclosure must meet the requirements of the standard IEC 60204-1.

7.9.8 Functional description

In case of use of the STO function the input STO- Enable must be connected to an exit of a security control or a safety relay, which meets at least to the requirements of the SIL CL2 according to IEC 62061 and PLd according to ISO 13849-1 (see diagram (→ # 40)).

Possible states of the servo amplifier in connection with STO function:

STO-ENABLE	ENABLE	Display	Torque	SIL2/PLd
0V	0V	-S-	no	yes
0V	+24V	F27	no	yes
+24V	0V	normal status e.g. 06	no	no
+24V	+24V	normal status e.g. E06	yes	no

NOTICE

Because STO is a single-channel system, erroneous engaging will not be recognized. Therefore the output of the control must be supervised for possible malfunction.

NOTICE

When wiring the STO inputs within an enclosure it must be paid attention to the fact that the used cables and the enclosure meet the requirements of IEC 60204-1.

If the wiring leads outside the demanded enclosure, the cables must be laid durably (firmly), and protected from outside damage (→ # 40).

NOTE

If the STO function is not needed in the application, then the input STO-ENABLE must be connected directly with +24VDC. STO is passed by now and cannot be used. Now the servo amplifier is not a safety component referring to the EC Machine Directive.

7.9.8.1 Safe operation sequence

If a controlled braking before the use of STO is necessary, the drive must be braked and the input STO-ENABLE has to be separated from +24 VDC time-delayed.

1. Brake the drive in a controlled manner (speed setpoint = 0V)
2. When speed = 0 rpm, disable the servo amplifier (enable = 0V)
3. If there is a suspended load, block the drive mechanically
4. Activate STO (STO-Enable = 0V)

The diagram shows how STO should be used to ensure a safe stop of the drive and error free operation of the servo amplifier.

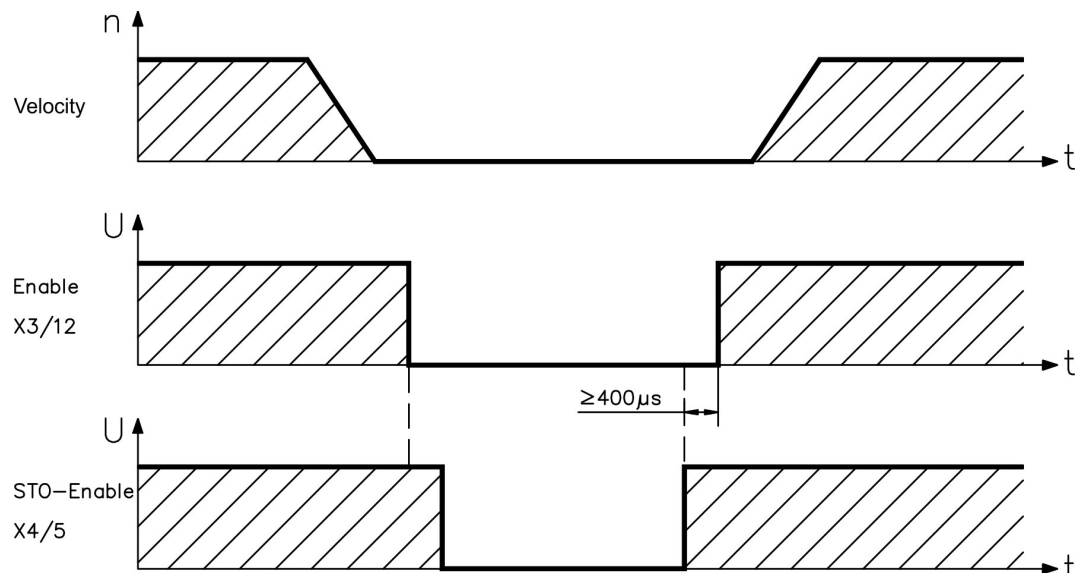

7.9.8.2 Control circuit

The example shows a circuit diagram with two separated work areas connected to one emergency stop circuit. For each work area individually "safe stop" of the drives is switched by a protective screen.

The safety switch gears used in the example are manufactured by Pilz and fulfill at least the PL d acc. to ISO 13849-1. Further information to the safety switch gears is available from Pilz. The use of safety switch gears of other manufacturers is possible, if these also fulfill the SIL CL 2 according to IEC 62061 and PL d according to ISO 13849-1.

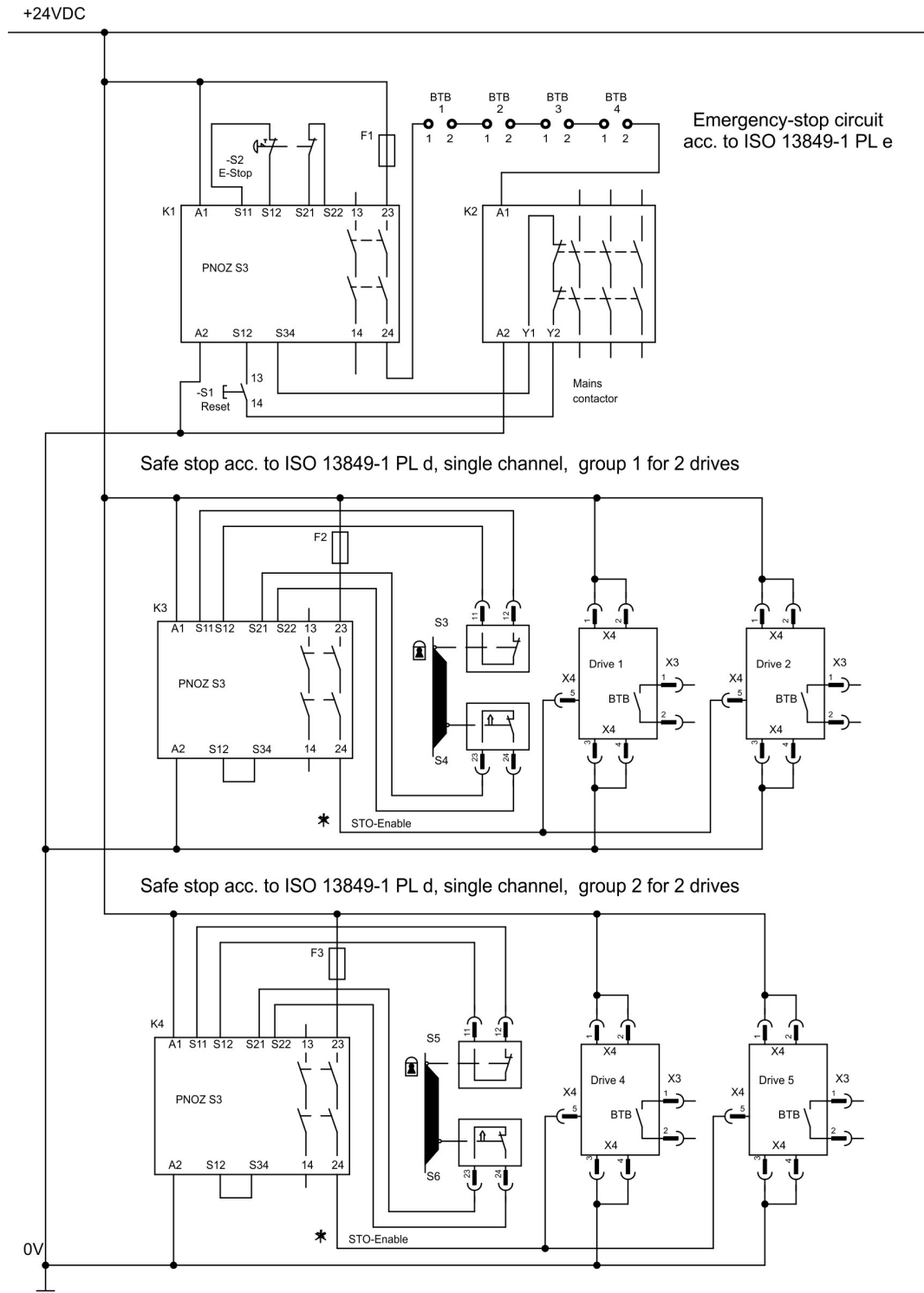

NOTE

Consider the wiring instructions (→ # 40).

7.9.8.3 Functional test

NOTICE

With initial starting and after each interference into the wiring of the drive or after exchange of one or several components of the drive the STO function must be tested.

1. Method:

1. Stop drive, with setpoint 0V, keep servo amplifier enabled (Enable=24V).

DANGER: Do not enter hazardous area!

2. Activate STO e.g. by opening protective screen (voltage at X4/5 = 0V).

Correct behavior: the BTB/RTO contact opens, the net contactor releases and the servo amplifier displays error F27.

2. Method:

1. Stop all drives, with setpoint 0V, disable servo amplifier (Enable=0V).

2. Activate STO e.g. by opening protective screen (voltage at X4/5 = 0V).

Correct behavior: the servo amplifier displays **-S-**.

7.9.8.4 Mains supply circuit

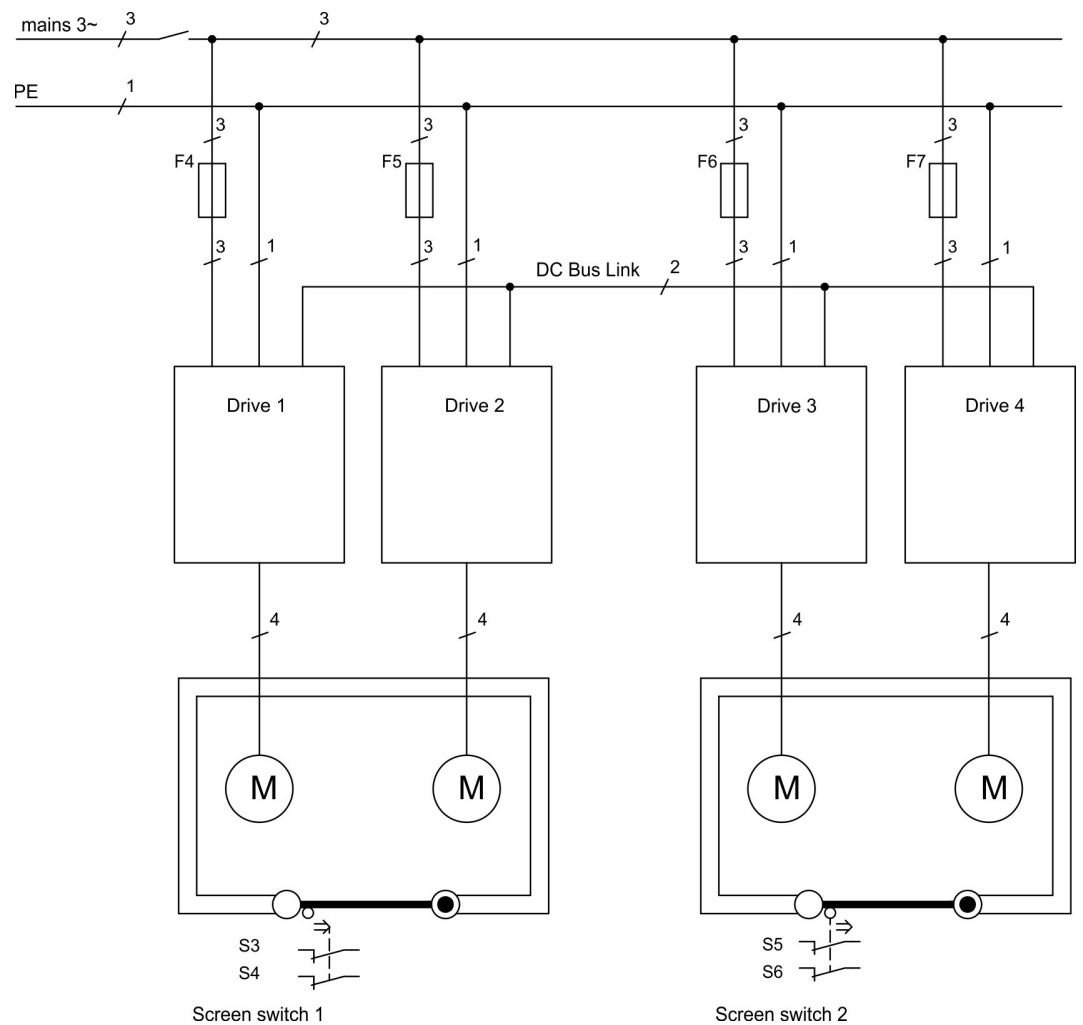

7.10 Shock-hazard Protection

7.10.1 Leakage current

Leakage current via the PE conductor results from the combination of equipment and cable leakage currents. The leakage current frequency pattern includes a number of frequencies, whereby the residual-current circuit breakers definitively evaluate the 50 Hz current. For this reason, the leakage current cannot be measured using a conventional multimeter. As a rule of thumb, the following assumption can be made for leakage current on our low capacitance cables at a mains voltage of 400 V, depending on the clock frequency of the output stage:

$I_{leak} = n \times 20 \text{ mA} + L \times 1 \text{ mA/m}$ at 8 kHz clock frequency at the output stage

$I_{leak} = n \times 20 \text{ mA} + L \times 2 \text{ mA/m}$ at a 16 kHz clock frequency at the output stage

(where I_{leak} =leakage current, n =number of drives, L =length of motor cable)

At other mains voltage ratings, the leakage current varies in proportion to the voltage.

Example:

2 x drives + a 25m motor cable at a clock frequency of 8 kHz:

$2 \times 20 \text{ mA} + 25 \text{ m} \times 1 \text{ mA/m} = 65 \text{ mA}$ leakage current.

NOTE

Since the leakage current to PE is more than 3.5 mA, in compliance with IEC61800-5-1 the PE connection must either be doubled or a connecting cable with a cross-section $>10 \text{ mm}^2$ must be used. Use the PE terminal and the PE connection screws in order to fulfill this requirement.

The following measures can be used to minimize leakage currents:

- Reduce the length of the engine cable.
- Use low-capacity cables (→ # 52).
- Remove external EMC filters (radio-interference suppressors are integrated).

7.10.2 Residual current protective device (RCD)

In conformity with IEC 60364-4-41 – Regulations for installation and IEC 60204 – Electrical equipment of machinery, residual current protective devices (RCDs) can be used provided the requisite regulations are complied with. The S300 is a 3-phase system with a B6 bridge. Therefore, RCDs which are sensitive to all currents must be used in order to detect any DC fault current. Refer to the chapter above for the rule of thumb for determining the leakage current. Rated residual currents in the RCDs:

10 to 30 mA	Protection against "indirect contact" for stationary and mobile equipment, as well as for "direct contact".
50 to 300 mA	Protection against "indirect contact" for stationary equipment

NOTE

Recommendation: In order to protect against direct contact (with motor cables shorter than 5 m) Kollmorgen recommends that each drive be protected individually using a 30 mA RCD which is sensitive to all currents.

If you use a selective RCD, the more intelligent evaluation process will prevent spurious tripping of the RCD.

7.10.3 Isolating transformers

When protection against indirect contact is absolutely essential despite a higher leakage current, or when an alternative form of shock-hazard protection is sought, the S300 can also be operated via an isolating transformer (schematic connection (→ # 58)). A ground-leakage monitor can be used to monitor for short circuits.

NOTE

Keep the length of wiring between the transformer and the S300 as short as possible.

8 Mechanical Installation

8.1 Important Notes



CAUTION High EMC Voltage Level!

Risk of electrical shock, if the servo amplifier (or the motor) is not properly EMC-grounded.

- Do not use painted (i.e. non-conductive) mounting plates.
- In unfavourable circumstances, use copper mesh tape between the earthing bolts and earth potential to deflect currents.

NOTICE

Protect the servo amplifier from impermissible stresses. In particular, do not let any components become bent or any insulation distances altered during transport and handling. Avoid contact with electronic components and contacts.

NOTICE

The servo amplifier will switch itself off in case of overheating. Ensure that there is an adequate flow of cool, filtered air into the bottom of the control cabinet, or use a heat exchanger. Observe (→ # 29).

NOTICE

Do not mount devices that produce magnetic fields directly beside the servo amplifier. Strong magnetic fields can directly affect internal components. Mount devices which produce magnetic field with distance to the servo amplifier and/or shield the magnetic fields.

8.2 Guide to Mechanical Installation

The following notes should assist you to carry out the mechanical installation in a sensible sequence, without overlooking anything important.

Site	<ul style="list-style-type: none"> • Mount in a closed switchgear cabinet. • The site must be free from conductive or corrosive materials. • For the mounting position in the cabinet refer to (→ # 46).
Ventilation	<ul style="list-style-type: none"> • Check that the ventilation of the servo amplifier is unimpeded and keep within the permitted ambient temperature (→ # 29). • Keep the required space clear above and below the servo amplifier (→ # 46).
Assembly	<ul style="list-style-type: none"> • Assemble the servo amplifier and power supply, filter and choke close together on the conductive, grounded mounting plate in the cabinet.
Grounding Shielding	<ul style="list-style-type: none"> • EMC-compliant (EMI) shielding and grounding see (→ # 56). • Earth (ground) the mounting plate, motor housing and CNC-GND of the controls. Notes for wiring technology (→ # 51)

8.3 Mounting

Material: 3 hexagon socket screws to EN 4762, M5

Tool required: 4 mm Allen key

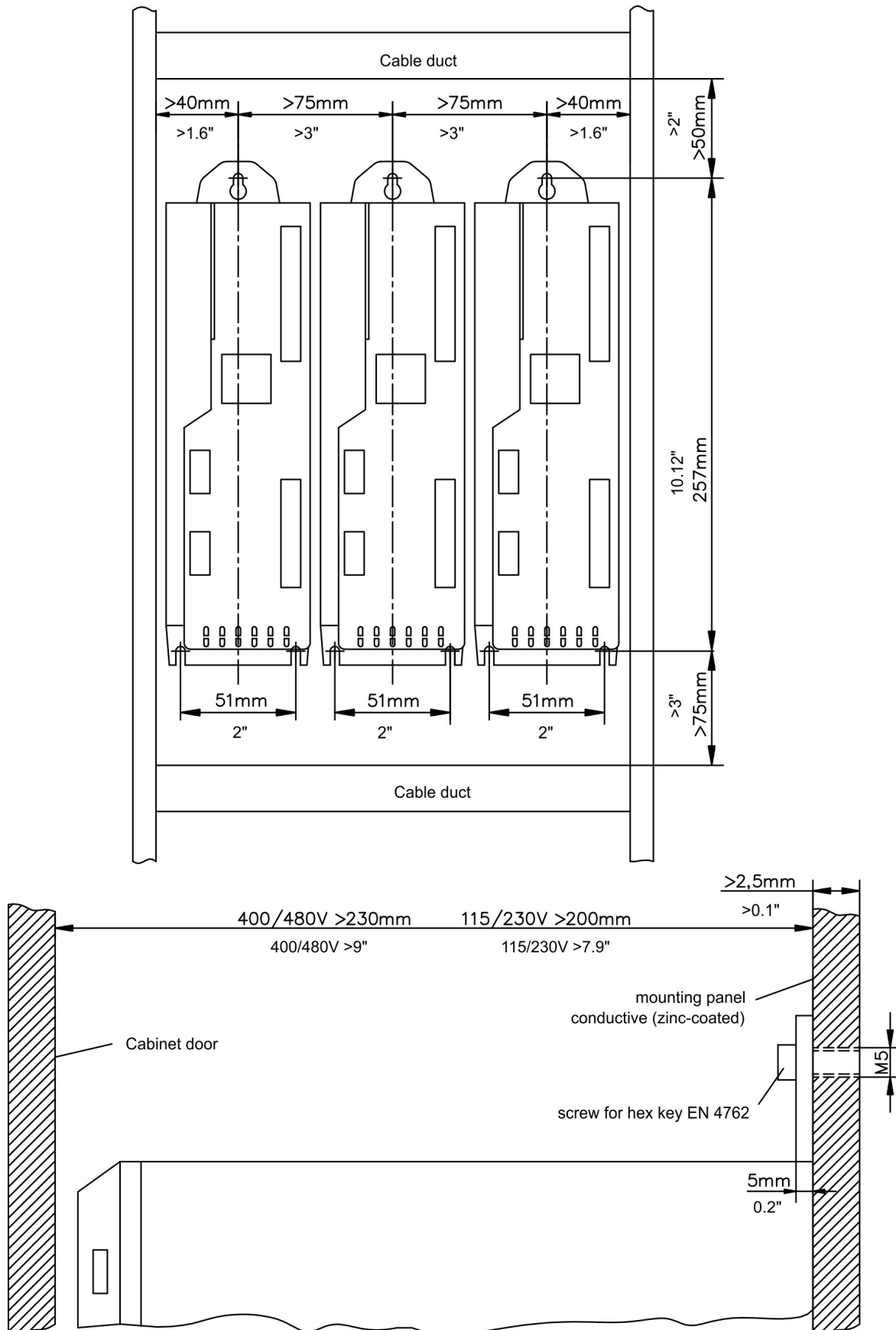

8.4 Dimensions

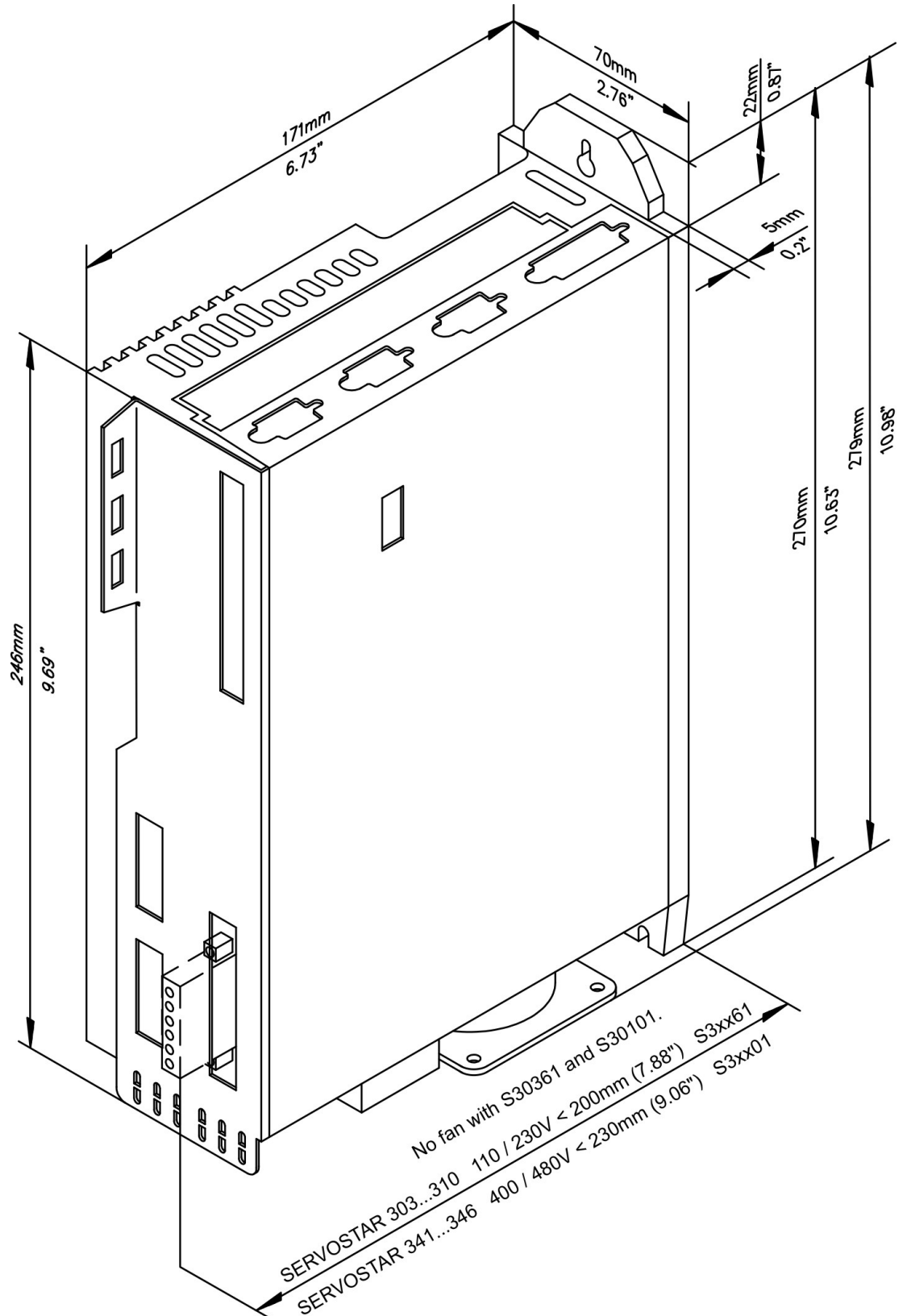

9 Electrical Installation

9.1 Important Notes

NOTICE

Only professional staff who are qualified in electrical engineering are allowed to install the drive. Wires with color green with one or more yellow stripes must not be used other than for protective earth (PE) wiring.



DANGER High Voltage up to 900 V!

There is a danger of serious personal injury or death by electrical shock or electrical arcing. Capacitors can still have dangerous voltages present up to 5 minutes after switching off the supply power. Control and power connections can still be live, even if the motor is not rotating.

- Only install and wire the equipment when it is not live.
- Make sure that the cabinet is safely disconnected (for instance, with a lock-out and warning signs).
- Never remove electrical connections to the drive while it is live.
- Wait at least 5 minutes after disconnecting the drive from the main supply power before touching potentially live sections of the equipment (e.g. contacts) or undoing any connections.
- To be sure, measure the voltage in the DC bus link and wait until it has fallen below 50 V.

NOTICE

Wrong mains voltage, unsuitable motor or wrong wiring will damage the amplifier. Check the combination of servo amplifier and motor. Compare the rated voltage and current of the units. Implement the wiring according to the connection diagram (→ # 56). Make sure that the maximum permissible rated voltage at the terminals L1, L2, L3 or +DC, –DC is not exceeded by more than 10% even in the most unfavorable circumstances (see IEC 60204-1).

NOTICE

Excessively high external fusing will endanger cables and devices. The fusing of the voltage supply must be installed by the user, best values (→ # 28). Hints for use of Residual-current circuit breakers (FI) see (→ # 44).

NOTICE

The servo amplifier's status must be monitored by the PLC to acknowledge critical situations. Wire the BTB/RTO contact in series into the emergency off circuit of the installation. The emergency off circuit must operate the supply contactor.

9.2 Guide to electrical installation

NOTICE

Correct wiring is the basis for reliable functioning of the servo system. Route power and control cables separately. We recommend a distance of at least 200mm. This improves the interference immunity. If a motor power cable is used that includes cores for brake control, the brake control cores must be separately shielded. Ground the shielding at both ends. Ground all shielding with large areas (low impedance), with metalized connector housings or shield connection clamps wherever possible.

Notes on connection techniques see (→ # 51).

NOTICE

Feedback lines may not be extended, since thereby the shielding would be interrupted and the signal processing could be disturbed. Lines between amplifiers and external brake resistor must be shielded. Install all power cables with an adequate cross-section, as per IEC 60204 (p.28) and use the requested cable material (→ # 52) to reach max. cable length.

The following notes should assist you to carry out the electrical installation in a sensible sequence, without overlooking anything important.

Cable selection	<ul style="list-style-type: none"> • Select cables according to EN 60204 (→ # 29)
Grounding Shielding	<ul style="list-style-type: none"> • EMC-compliant (EMI) shielding and grounding see (→ # 56) • Earth (ground) the mounting plate, motor housing and CNC-GND of the controls. Notes on connection techniques see (→ # 51).
Wiring	<ul style="list-style-type: none"> • Route power leads and control cables separately • Wire the BTB/RTO contact in series into the emergency off circuit of the system. • Connect the digital control inputs to the servo amplifier • Connect up AGND (also if fieldbuses are used) • Connect the analog setpoint, if required • Connect up the feedback unit (resolver and/or encoder) • Connect the encoder emulation, if required • Connect the expansion card (see corresponding notes from (→ # 115)) • Connect the motor cables, connect shielding to EMI connectors at both ends. Use motor chokes (3YL/3YLN) for lead lengths >25m. • Connect motor-holding brake, connect shielding to EMC connector/shield connection at both ends. • Connect the external brake resistor (with fusing) if required • Connect aux. supply (for max. permissible voltage values (→ # 29)) • Connect main power supply (for max. permissible voltage values (→ # 29)) • Connect PC (→ # 95).
Final check	<ul style="list-style-type: none"> • Final check of the implementation of the wiring, according to the wiring diagrams which have been used.

9.3 Wiring

The installation procedure is described as an example. A different procedure may be appropriate or necessary, depending on the application of the equipments. We provide further know-how through training courses (on request).





⚠ DANGER High voltage up to 900V!

There is a danger of electrical arcing with damage to contacts and serious personal injury.

- Only install and wire up the equipment when it is not live, i.e. when neither the electrical supply nor the 24 V auxiliary voltage nor the supply voltages of any other connected equipment is switched on.
- Make sure that the cabinet is safely disconnected (for instance, with a lock-out and warning signs).

NOTE

The ground symbol , which you will find in all the wiring diagrams, indicates that you must take care to provide an electrically conductive connection with the largest feasible surface area between the unit indicated and the mounting plate in the control cabinet.

This connection is for the effective grounding of HF interference, and must not be confused with the PE-symbol  (PE = protective earth, safety measure as per IEC 60204).

Use the following connection diagrams :

Safe Torque Off (STO)	(→ # 38)
Overview	(→ # 56)
Power supply	(→ # 58)
DC Bus link	(→ # 61)
Motor	(→ # 64)
Feedback	(→ # 65)
Digital and analog inputs and outputs	(→ # 92)
RS232 / PC	(→ # 95)
CAN Interface	(→ # 96)

Electronic Gearing:

Puls-Richtung	(→ # 88)
Master-Slave	(→ # 89)

Encoder Emulation

ROD (A quad B)	(→ # 90)
SSI	(→ # 91)

Expansion cards :

I/O-14/08:	(→ # 116)
PROFIBUS:	(→ # 119)
sercos® II:	(→ # 120)
DeviceNet:	(→ # 122)
SynqNet:	(→ # 125)
FB-2to1:	(→ # 127)
-2CAN-:	(→ # 131)

Options:

EtherCAT	(→ # 133)
FAN	(→ # 134)

9.3.1 Shielding connection to the front panel

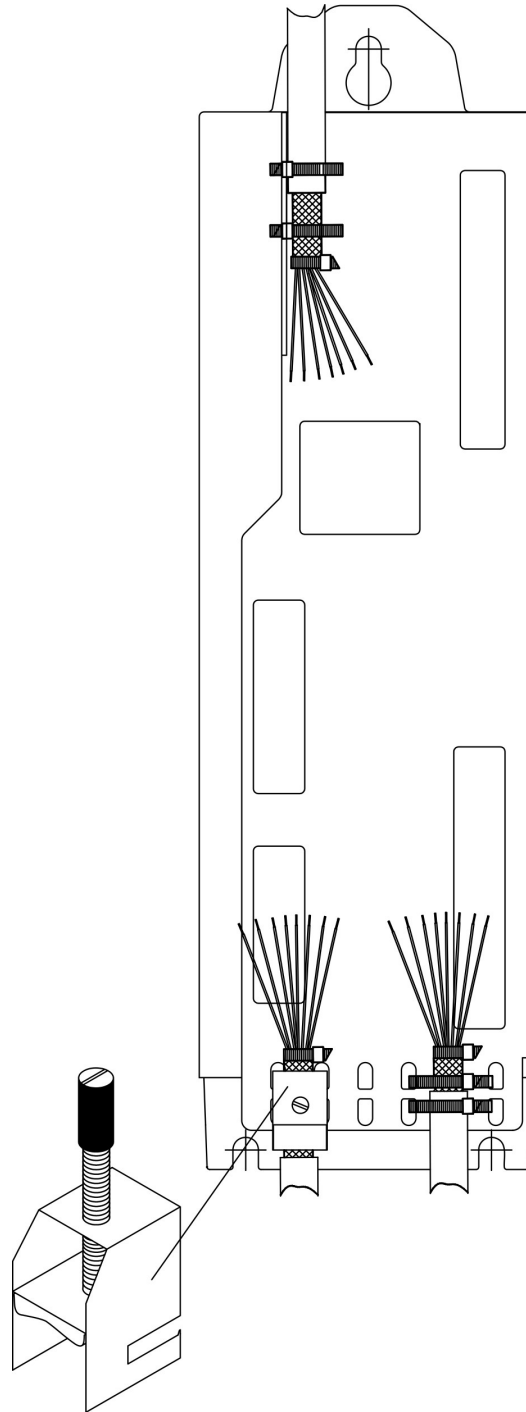

Remove the outside shroud of the cable and the shielding braid on the desired core length. Secure the cores with a cable tie.

Remove the outside shroud of the line on a length from for instance 30mm without damaging the shielding braid.

Pull a cable tie by the slot in the shielding rail on the front panel of the servo amplifier.

Press the shielding of the cable firmly against the front panel with the cable tie.

Use the shield clamp that is delivered with the motor cable for the shield connection of the motor cable. The clamp must be hooked in the lower shroud and guarantees optimal contact between shield and shroud.

9.3.2 Technical data for cables

For further information on the chemical, mechanical and electrical characteristics of the cables please refer to the accessories manual or contact our customer service.

NOTE

Observe the rules in the section "Conductor cross-sections" (→ # 29). To reach the max. permitted cable length, you must use cable material that matches the capacitance requirements listed below.

Capacitance (core to shield)

Motor cable less than 150 pF/m

Feedback cable less than 120 pF/m

Example Motor cable:

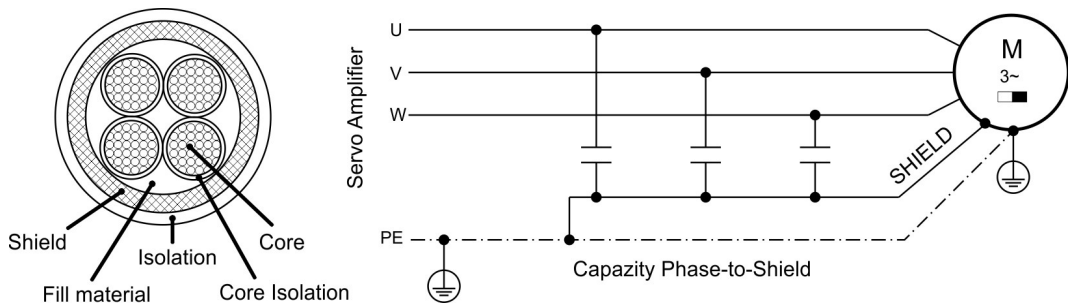

Technical data

For a detailed description of Kollmorgen cable types and how to assemble them, please refer to the accessories manual.

Chokes

NOTE

Motor cables longer than 25m require the use of a motor choke 3YL or 3YLN.

9.4 Components of a servo system

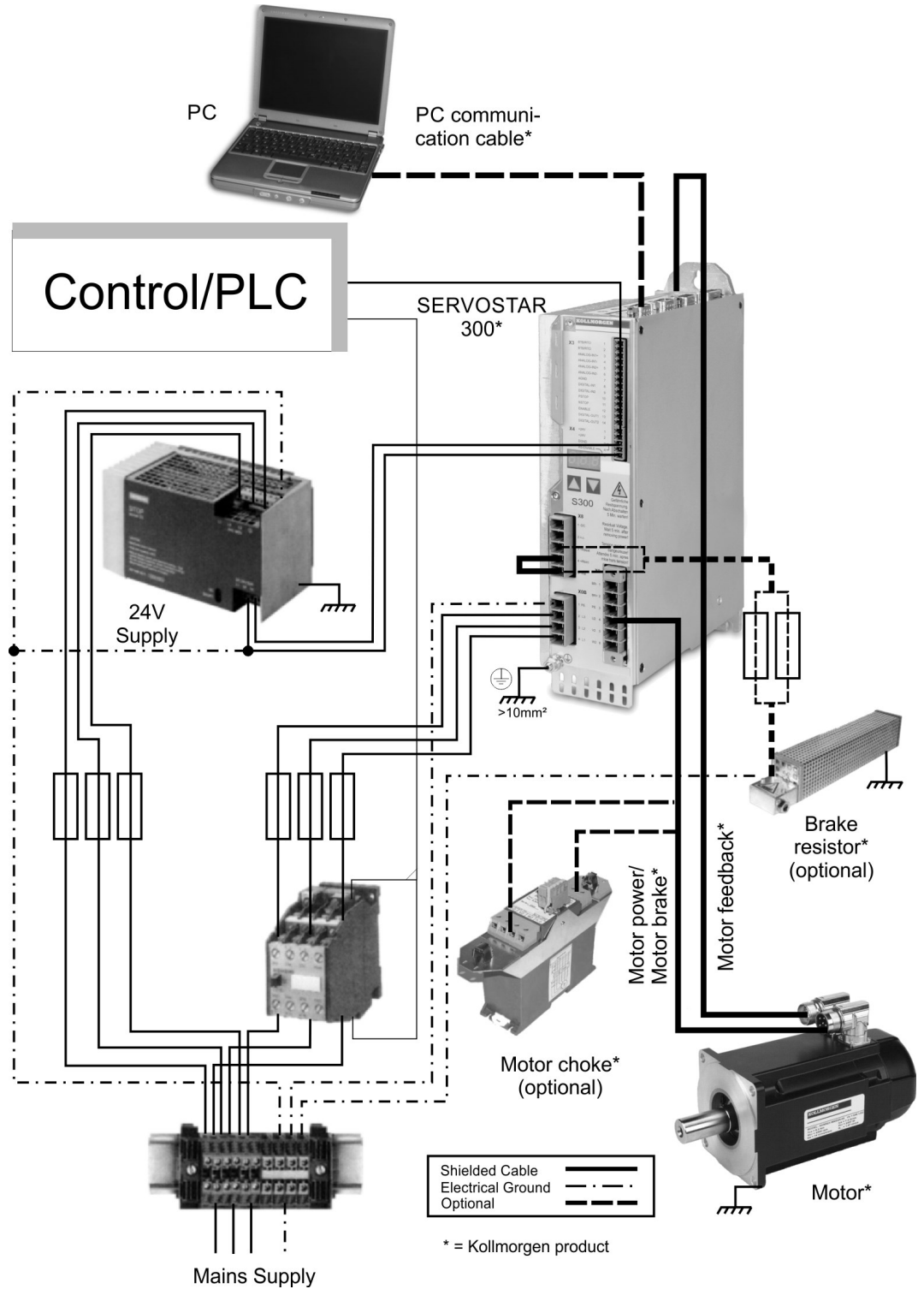

NOTE

Cables drawn bold are shielded. Electrical ground is drawn with dash-dotted lines. Optional devices are connected with dashed lines to the servo amplifier. The required accessories are described in our accessories manual. STO function is deactivated in the example.

9.5 Block diagram

The block diagram below just provides an overview.

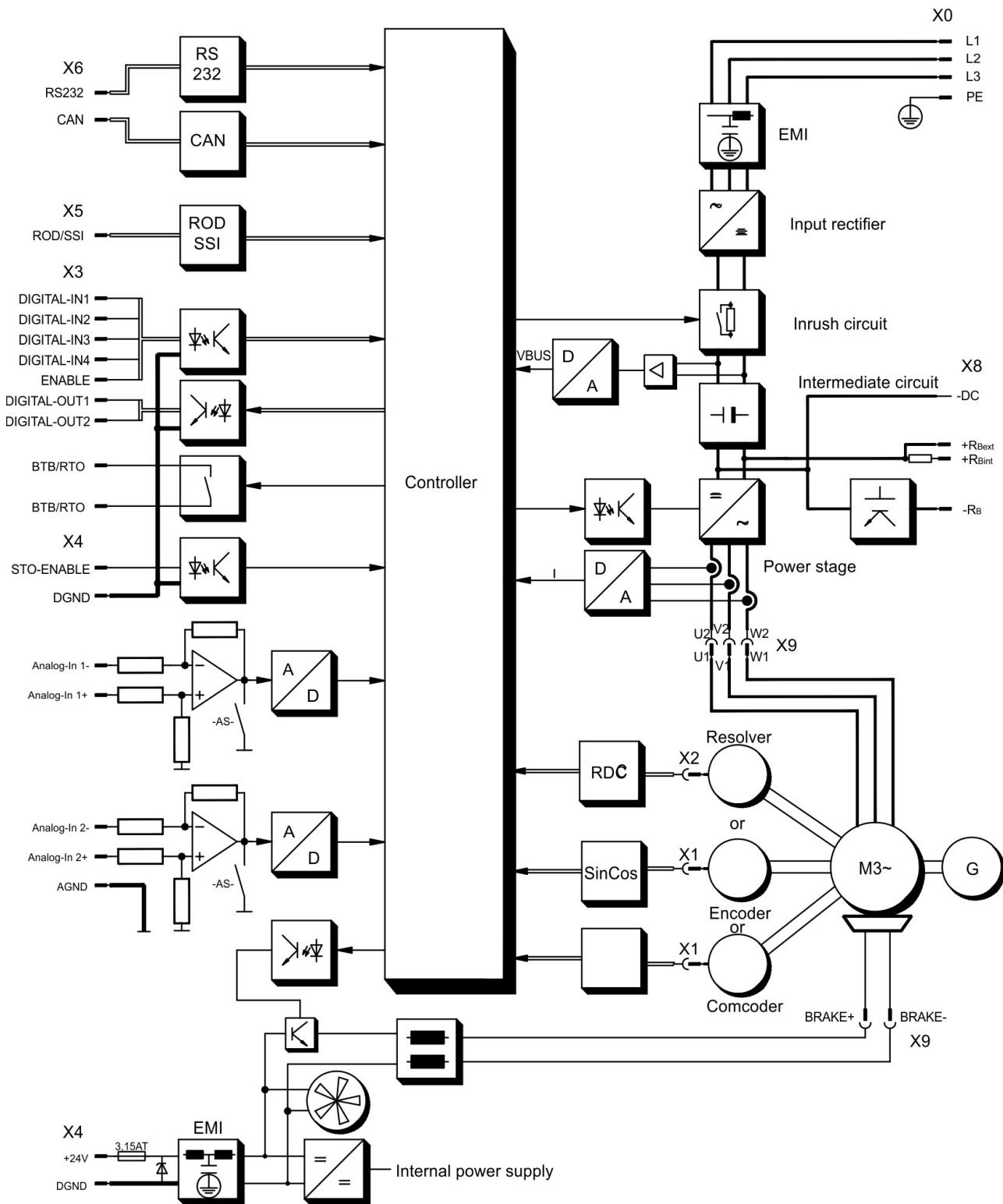

9.6 Connector assignment

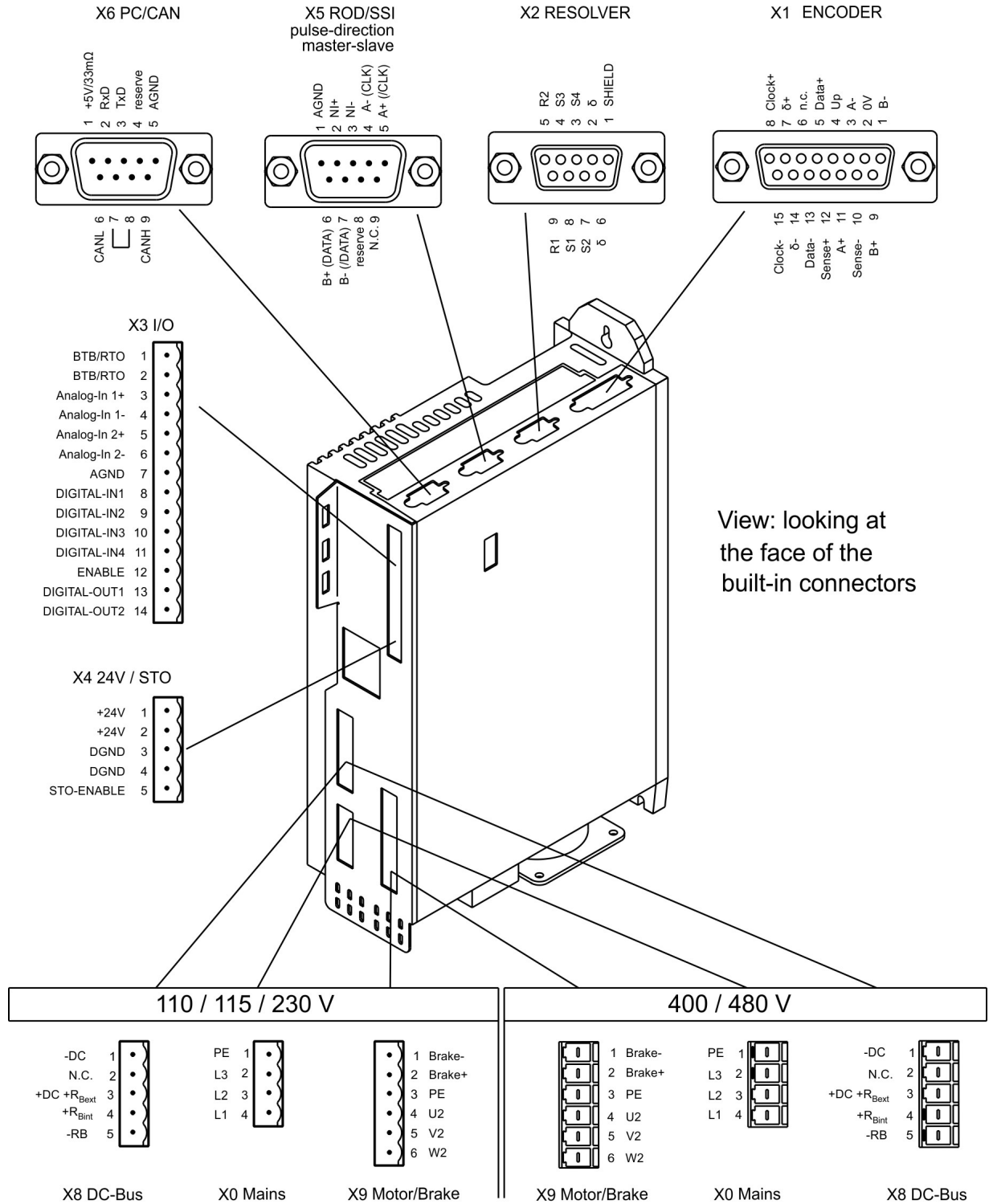

■ Coding Keys

9.7 Connection overview

Refer to the Safety Instructions (→ # 12) and Use as Directed (→ # 15)!

"Single Cable"

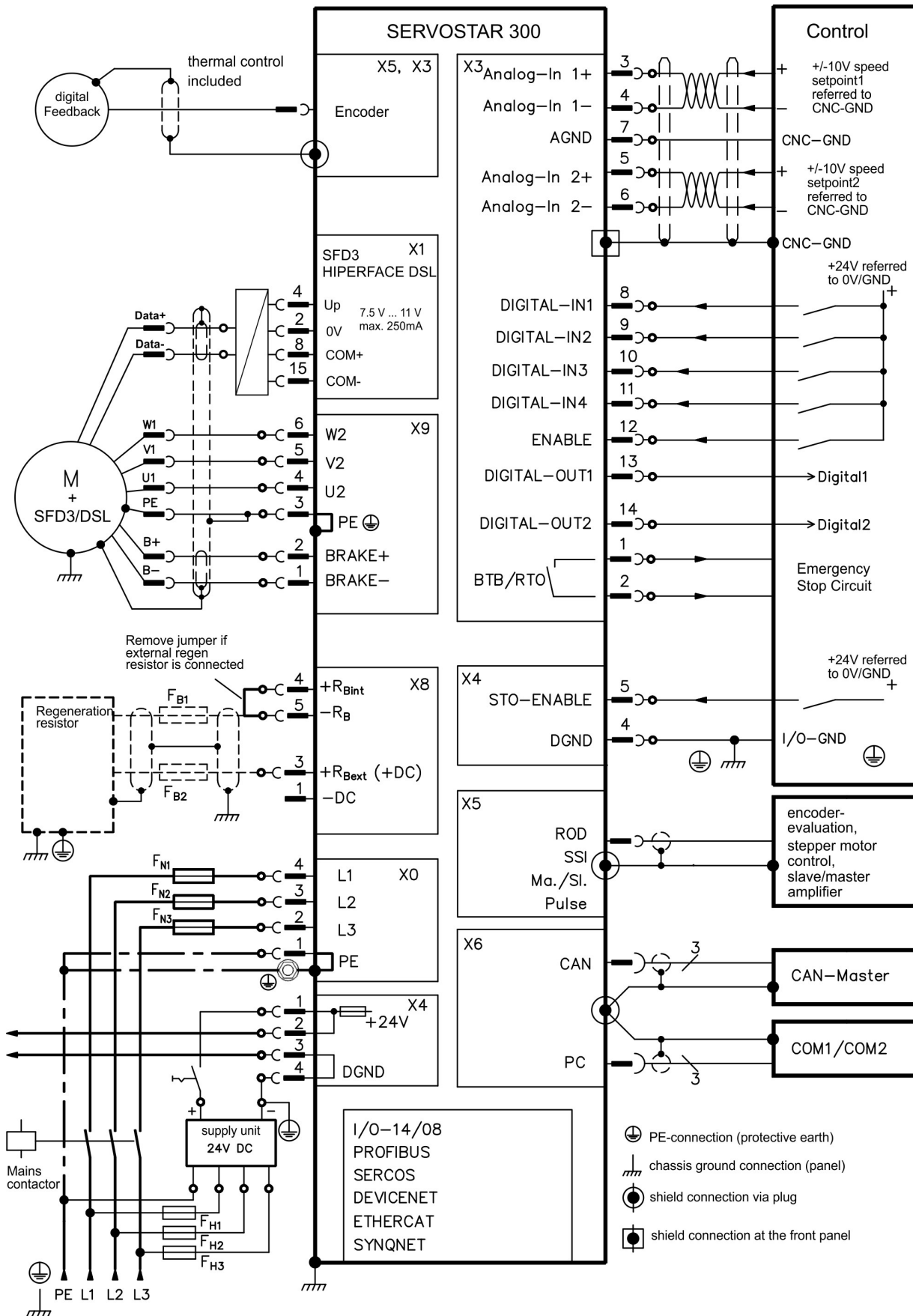

"Dual Cable"

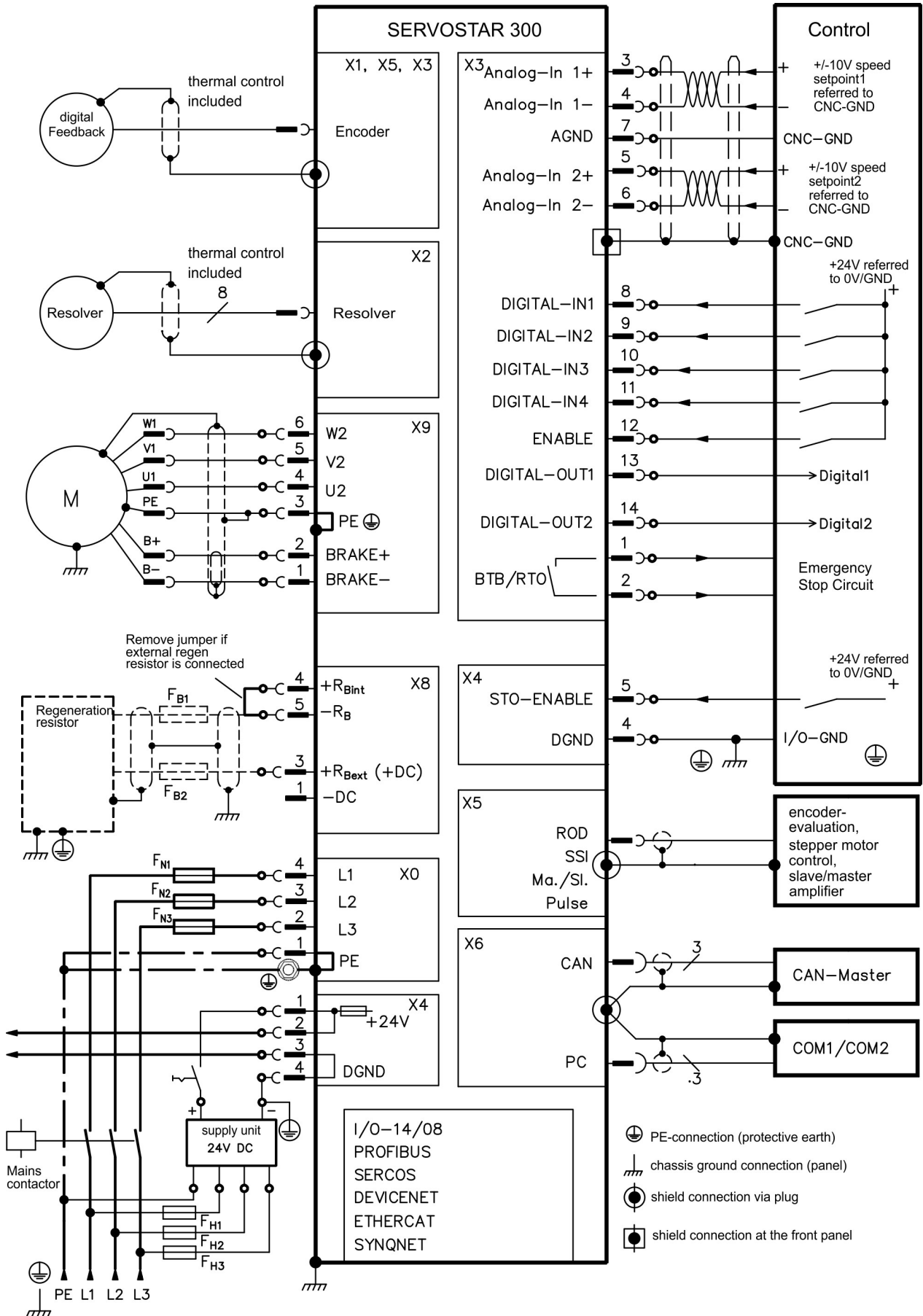

9.8 Voltage supply

9.8.1 Connection to various mains supply networks

NOTICE

An isolating transformer is required for 400V to 480V networks that are asymmetrically grounded or not grounded as shown below.

110V : SERVOSTAR 303-310*

230V : all Models

400V / 480V : SERVOSTAR 341-346*

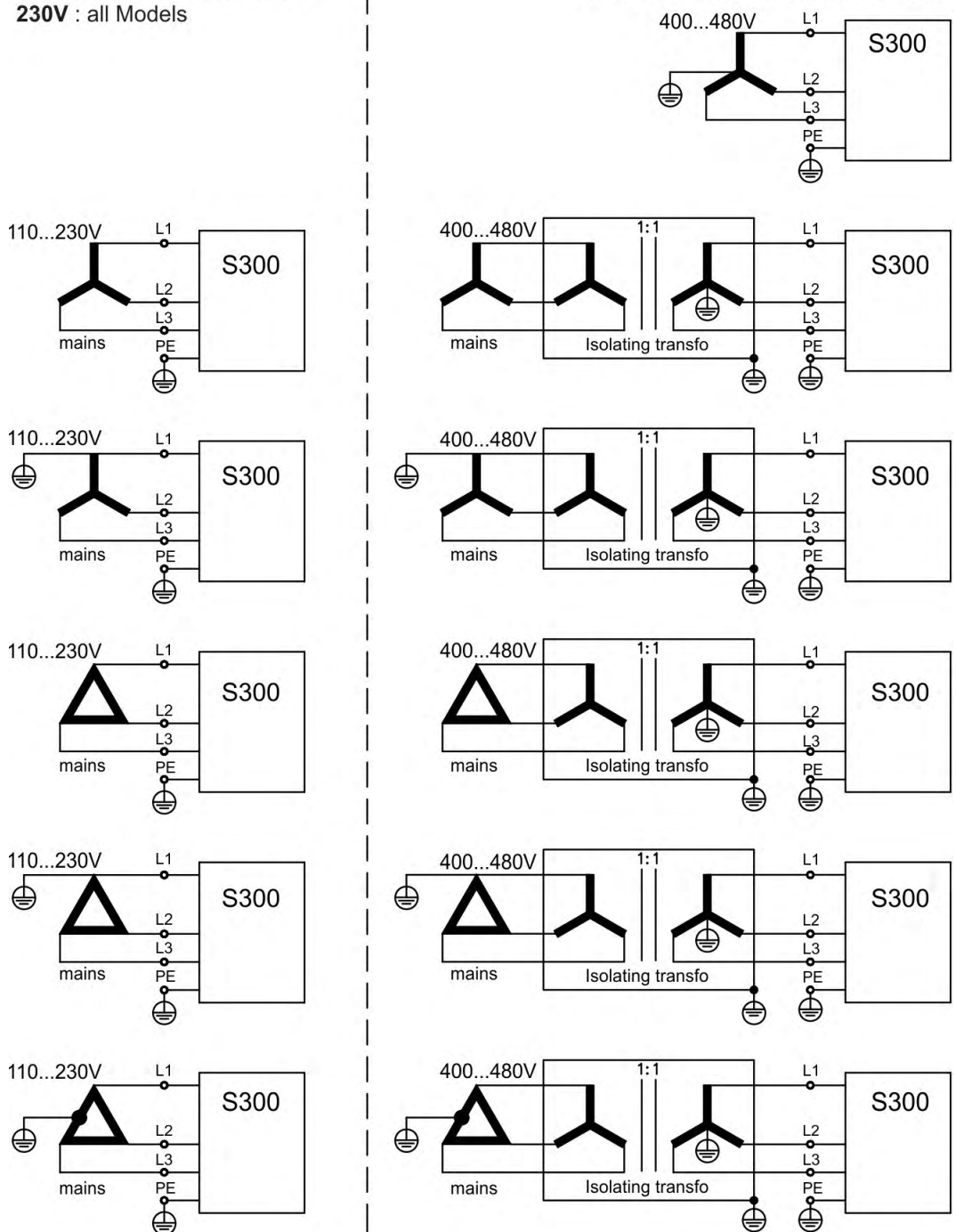

* Order code reference see (→ # 137)

9.8.2 24V auxiliary supply (X4)

- External 24V DC power supply, electrically isolated, e.g. via an isolating transformer
- Required current rating(→ # 28)
- Integrated EMC filter for the 24V auxiliary supply

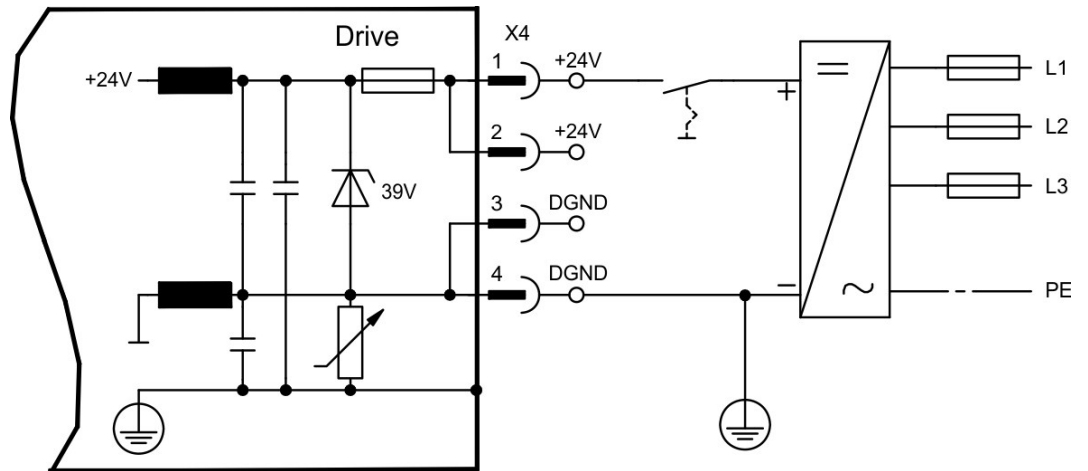

9.8.3 Mains supply connection (X0), three phase

- Directly to 3-phase supply network, filter is integrated
- Fusing (e.g. fusible cut-outs) to be provided by the user (→ # 28)

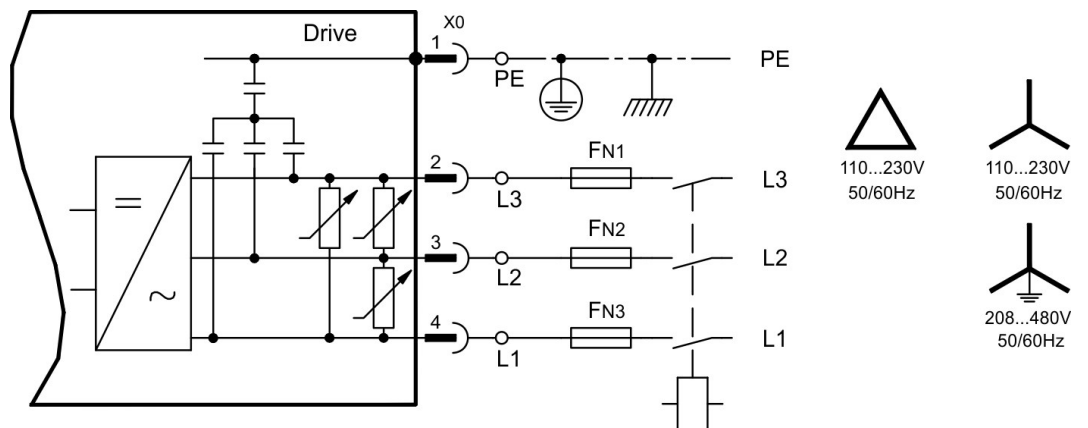

9.8.4 Mains supply connection (X0), two phase without neutral

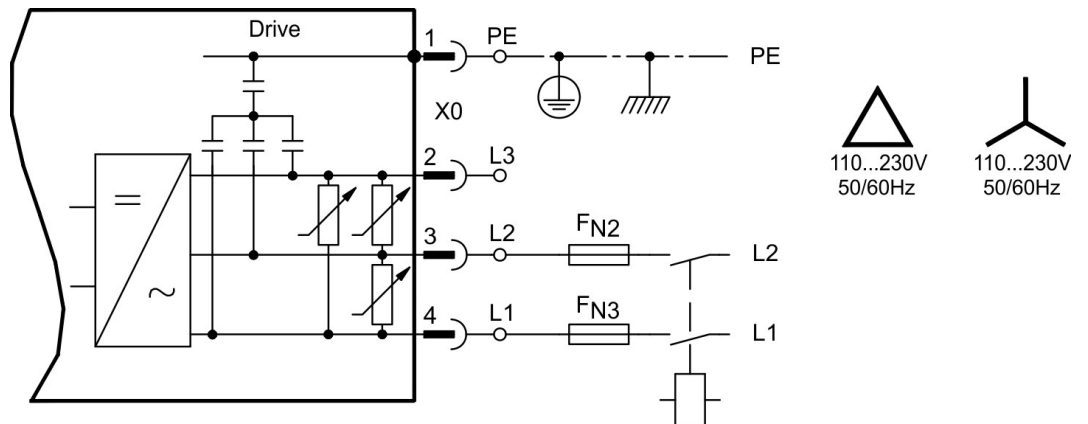

9.8.5 Mains supply connection (X0), single phase with neutral

S300 with 230V version (SERVOSTAR 303-310) can be operated with a single phase mains supply. In single phase operation the electrical power of the amplifier is limited.

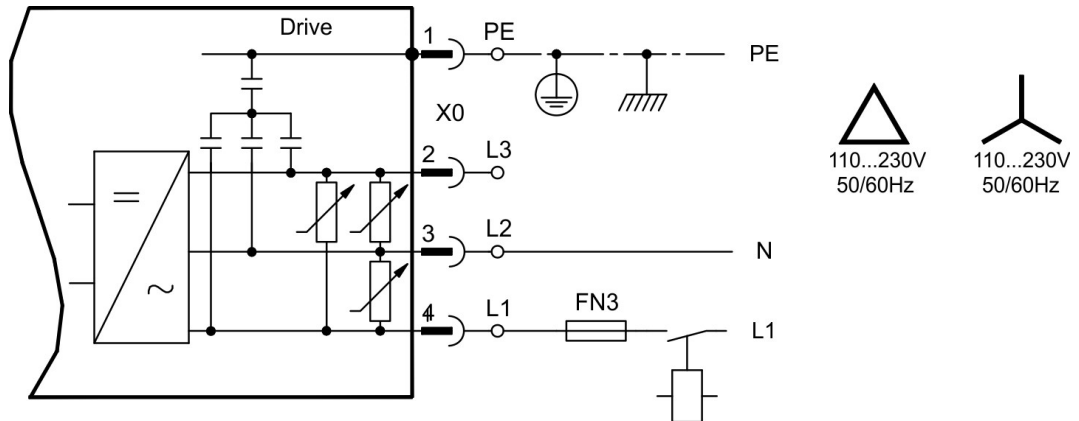

The table below shows the maximum rated power (Pn) and peak power (Pp) with single phase operation:

max. electrical power	S303 Pn/W		S306 Pn/W		S310 Pn/W	
VBUSBAL0 (110V)	423	704	423	704	423	704
VBUSBAL1 (230V)	845	2535	1127	2535	1127	2535

The maximum possible current depends on the motor torque constant kT and on the maximum speed of the connected motor:

$$\text{Cont. Current: } I_{rms} = \frac{P_n * 60}{2 * \pi * k_T * n}$$

$$\text{Peak Current: } I_{peak} = \frac{P_p * 60}{2 * \pi * k_T * n}$$

NOTE

Speed can be limited with the ASCII parameter VLIM to reach the necessary current for the required torque.

With a special motor type (kT = constant depending on the motor type) the possible output current depending on speed is similar to the diagram below:

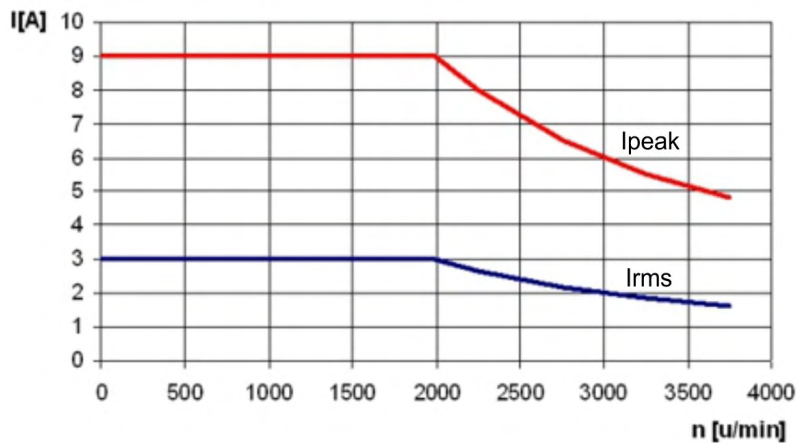

9.9 DC bus link (X8)

Terminals X8/1 (-DC) and X8/3 (+RBext) can be connected in parallel. The brake power is divided between all the amplifiers that are connected to the same DC bus link circuit.

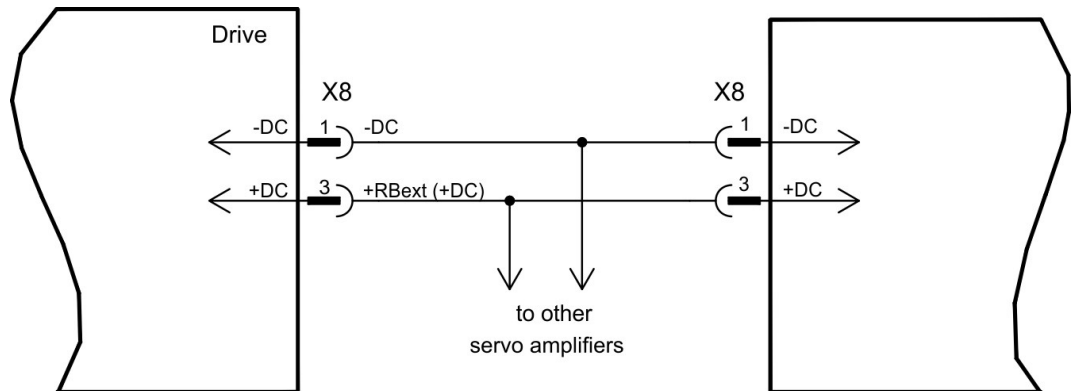

NOTICE

- The servo amplifiers can be destroyed, if DC bus link voltages are different. Only servo amplifiers with mains supply from the same mains (identical mains supply voltage) may be connected by the DC bus link.
- Use 2,5 mm², unshielded single cores with a max. length of 200mm; use 6mm² shielded cables for longer lengths. In this case no fuse for line protection is required.
- Servo amplifiers working generatively very often, should be placed beside amplifiers, which need energy. That reduces current flow on longer distances.

	S300	S701-724 with HWR* < 2.00	S701-724 with HWR* ≥ 2.10	S748/S772
S300	yes	no	s	no

*HWR = Hardware Revision (see nameplate)

SERVOSTAR 303-310: The sum of the rated currents for all of the servo amplifiers connected in parallel to an SERVOSTAR 303-310 must not exceed 24 A.

SERVOSTAR 341-346: The sum of the rated currents for all of the servo amplifiers connected in parallel to an SERVOSTAR 341-346 must not exceed 40A.

Fusing information are explained in detail in the KDN on page "[DC Bus link in parallel](#)".

9.9.1 External brake resistor (X8)

Remove the plug-in link between the terminals X8/5 (-RB) and X8/4 (+RBint). Fusing (→ # 28).

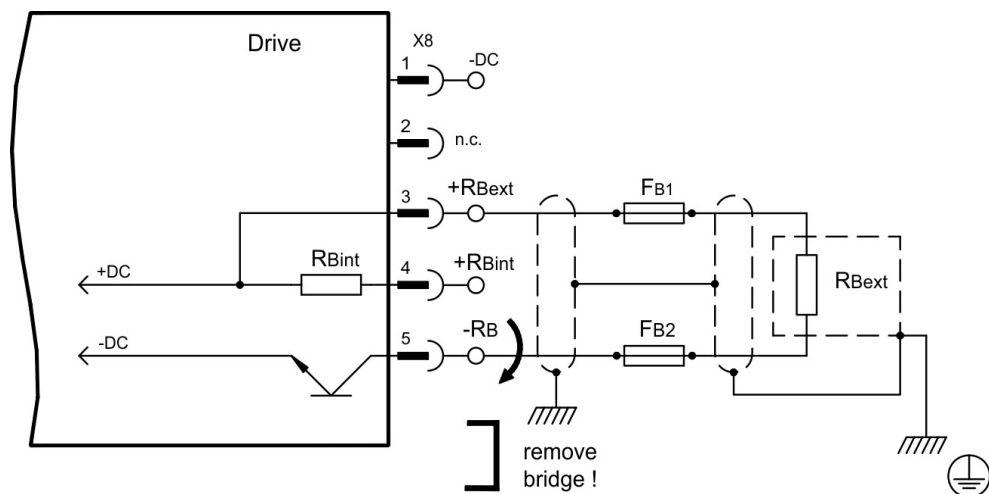

9.9.2 Capacitor Module KCM (X8)

The **KCM** modules (**K**OLL**M**ORGEN **C**apacitor **M**odule) absorb energy generated by the motor when it is operating in generator mode. Normally, this energy is dissipated as waste via brake resistors. KCM modules, however, feed the energy they have stored back into the DC Bus link as and when it is required.

Dimensions (HxWxD) : 300x100x201 mm

KCM-S	Saves energy: The energy stored in the capacitor module during regenerative braking is available the next time acceleration happens. The module's inception voltage is calculated automatically during the first load cycles.
KCM-P	Power in spite of power failure: If the power supply fails, the module provides the servo amplifier with the stored energy that is required to bring the drive to a standstill in a controlled manner (this only applies to the power supply voltage; battery-back the 24 V supply separately).
KCM-E	Expansion module for both applications. Expansion modules are available in two capacitance classes.

NOTE

The KCM modules can be connected to S3xx0 devices (mains supply voltage 400/480V). Information for mounting, installation and setup can be found in the KCM Instructions Manual and in [KDN](#).

Technical Data of KCM Modules

Type	Storage capacity [Ws]	Rated supply voltage [V=]	Peak supply voltage [V=]	Mains [kW]	Protection class	Inception voltage [V=]	Weight [kg]
KCM-S200	1600	max. 850 VDC	max. 950VDC (30s in 6min)	18	IP20	ermittelt	6.9
KCM-P200	2000					470 VDC	6.9
KCM-E200	2000					-	4.1
KCM-E400	4000					-	6.2

Dimension drawings and order information see regional accessories manual.



DANGER High DC voltage up to 900 V!

There is a danger of serious personal injury or death by electrical shock or electrical arcing. It can take over an hour for the modules to self-discharge.

- Switch off (disconnect) the line voltage. You must only work on the connections when the system is disconnected.
- Check the state of charge with a measuring device that is suitable for a DC voltage of up to 1,000 V.
- When measuring a voltage of over 50V between the DC+/DC- terminals or to ground, wait some minutes and measure again or discharge the modules as described in the KCM instructions manual.

Wiring example KCM Modules

NOTICE

Maximum cable length between servo amplifier and S300 module: 500 mm. Twist the cables +DC/-DC. Longer cable lengths require shielding. Ensure that the polarity is correct; swapping round DC+/DC- will destroy the KCM modules.

KCM-S: Connect the BR connection to the S300 with the most frequent regenerative braking processes in the system. For setup, enable the S300 and operate the driving profile that causes the brake chopper to respond. The KCM-S determines the chopper threshold and begins to charge; LED flashes. The energy stored is available the next time acceleration happens.

KCM-P: The KCM-P begins the charging process at approx. 470 V DC; the LED flashes. If the power supply fails, the module provides the servo amplifier with the stored energy that is required to bring the drive to a standstill in a controlled manner (this only applies to the power supply voltage; battery-back the 24 V supply separately).

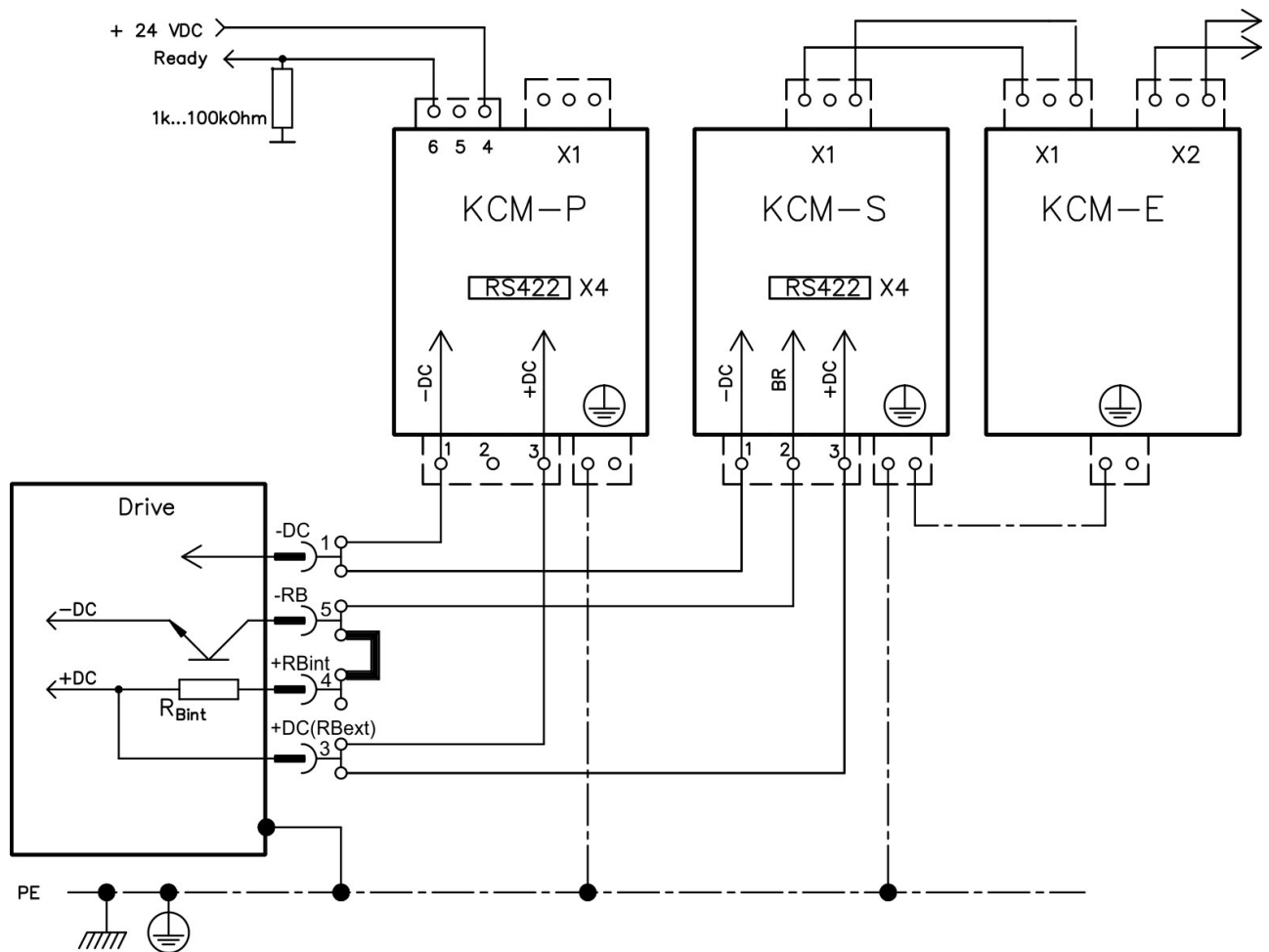

9.10 Motor power and motor holding brake connection (X9)

Together with the motor supply cable and motor winding, the power output of the servo amplifier forms an oscillating circuit. Characteristics such as cable capacity, cable length, motor inductance, frequency and voltage rise speed (see Technical Data,) (→ # 26) determine the maximum voltage in the system.

NOTICE

The dynamic voltage rise can lead to a reduction in the motor's operating life and, on unsuitable motors, to flash overs in the motor winding.

- Only install motors with insulation class F (acc. to IEC 60085) or above
- Only install cables that meet the requirements on (→ # 29) and (→ # 52).



CAUTION No functional safety!

Serious injury could result when a suspended load is not properly blocked.

- An additional mechanical brake is required for functional safety, which must be safely operated.

Wiring with cable length ≤ 25 m

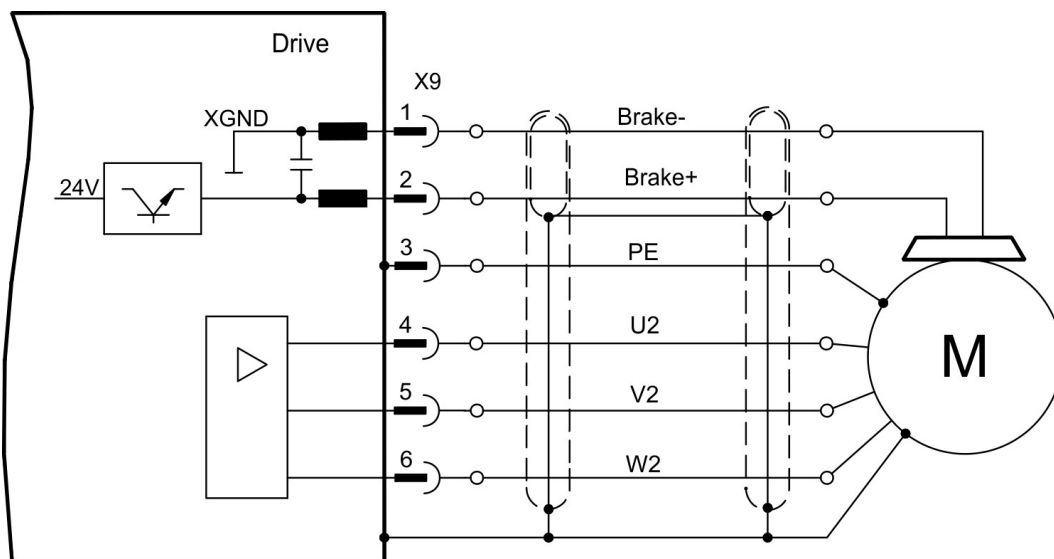

Wiring with cable length >25 m

NOTICE

With long motor cables leakage currents endanger the output stage of the servo amplifier. For cable lengths above 25m up to max. 50m, the motor choke 3YL or 3YLN (see accessories manual) must be wired into the motor cable, close to the amplifier.

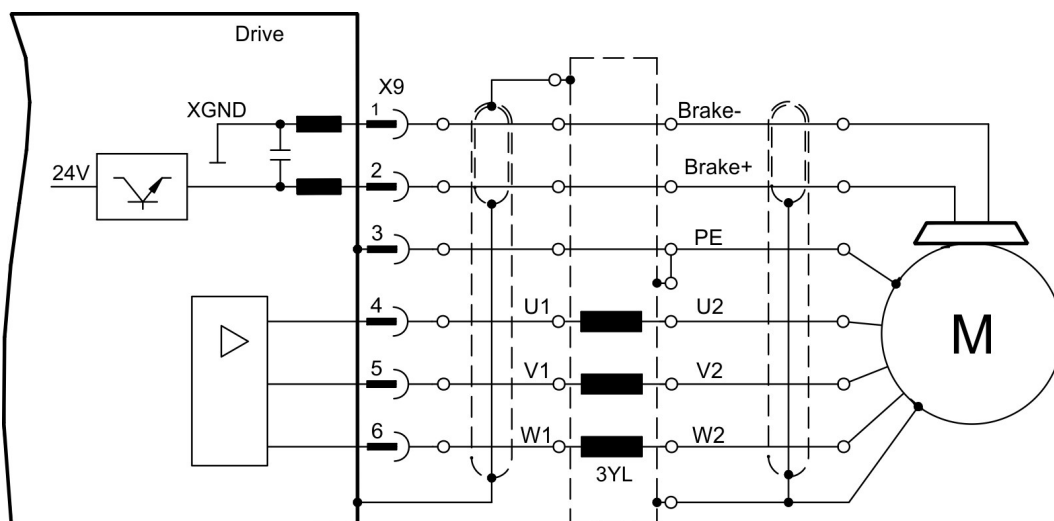

9.11 Feedback systems

Every closed servo system will normally require at least one feedback device for sending actual values from the motor to the servo drive. Depending on the type of feedback device used, information will be fed back to the servo amplifier using digital or analog means.

NOTE

The digital feedback systems SFD3 and HIPERFACE DSL enable a single cable motor connection (motor power and feedback signals in one cable) to the S300 connectors X9/X1.

NOTE

The expansion card FB2to1 (→ # 127) enables simultaneous connection of a digital primary feedback and of an analog secondary feedback to the connector X1.

Up to three feedback devices can be used at the same time. S300 supports the most common types of feedbacks whose functions must be assigned with the parameters

FBTYPE DRIVEGUI.EXE screen page FEEDBACK, primary Feedback (→ # 66)

EXTPOS Screen page POSITION CONTROLLER, secondary position (→ # 66)

GEARMODE Screen page ELECTRONIC GEARING, encoder control (→ # 87)

in the setup software. Scaling and other settings must always be made here.

For a detailed description of the ASCII parameters, please refer to the DRIVEGUI.EXE [Online-Help](#).

Some possible configurations

Motor Feedback



Motor Feedback & External Position Feedback

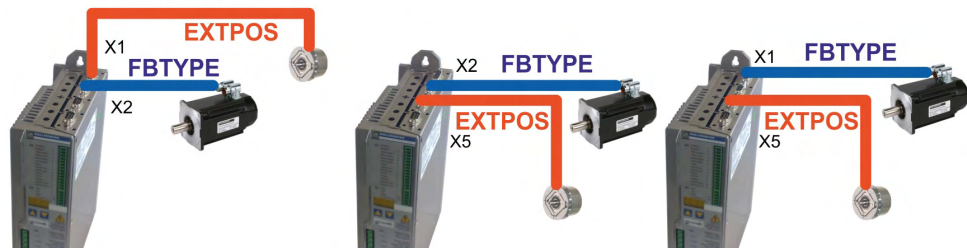

Motor Feedback & Master Slave

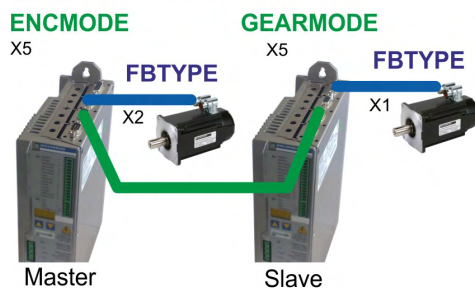

Motor Feedback & Master Slave & External Position Feedback

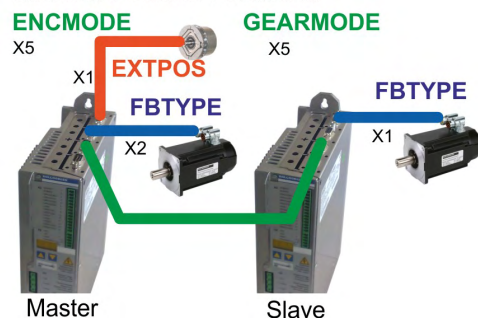

9.12 Primary and secondary feedback types

This chapter provides an overview of the supported feedback types, their corresponding parameters and a reference to the relevant connection diagram in each case.

Single Cable connection (Power and Feedback in one cable)

 <p>SFD3 HIPERFACE DSL</p>	S30361-NA, S30661-NA, S31061-NA	CCJ5, WCJ5
	S30101-NA, S30301-NA, S30601-NA	CCJ6, WCJ6

Feedback type	Connector	Wiring	primary FBTYPE	secondary EXTPOS
SFD3	X1	(→ # 67)	36	-
HIPERFACE DSL	X1	(→ # 68)	35	-

Dual cable connection (Power and Feedback separated)

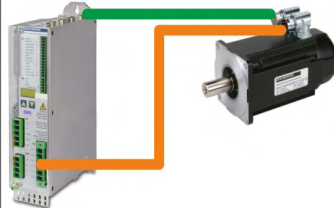
	Motor cables and Feedback cables see Accessories Manual
---	---

Feedback type	Connector	Wiring	primary FBTYPE	secondary EXTPOS
Resolver	X2	(→ # 69)	0	-
SinCos Encoder BiSS (B) analog	X1	(→ # 70)	23, 24	-
Encoder BiSS (B, C ²) digital	X1	(→ # 71)	20, 22, 33	11, 12
SinCos Encoder ENDAT 2.1	X1	(→ # 72)	4, 21	8
Encoder ENDAT 2.2	X1	(→ # 73)	32, 34	13
SinCos Encoder HIPERFACE	X1	(→ # 74)	2	9
SinCos Encoder SSI (linear)	X5/X1	(→ # 75)	28 ₁)	-
SinCos Encoder without data channel	X1	(→ # 76)	1, 3, 7, 8	6, 7
SinCos Encoder + Hall	X1	(→ # 77)	5, 6	-
ROD* 5V without zero, 1.5MHz	X1	(→ # 78)	30, 31	30
ROD* 5V with zero, 350kHz	X1	(→ # 79)	17, 27	10
ROD* 5V with zero + Hall	X1	(→ # 80)	15	-
ROD* 5V with zero	X5/X1	(→ # 81)	13 ₁), 19 ₁)	3
ROD* 5V with zero + Hall	X5/X1	(→ # 82)	18	-
ROD* 24V without zero	X3	(→ # 83)	12, 16	2
ROD* 24V without zero + Hall	X3/X1	(→ # 84)	14	-
SSI	X5/X1	(→ # 85)	9 ₁)	5 ₁)
Hall	X1	(→ # 86)	11	-
Step/Direction 5V	X1	(→ # 88)	-	27
Step/Direction 5V	X5	(→ # 88)	-	4
Step/Direction 24V	X3	(→ # 88)	-	1
Sensorless (without Feedback)	-	-	10	-

* * ROD is an abbreviation for "incremental encoder".

1) Switch on the encoder supply voltage on X1: set ENCVON to 1

2) BiSS C support for Renishaw encoders, Hengstler encoders are not supported.

9.12.1 SFD3 (X1), single cable connection

Connection of the Kollmorgen feedback system SFD3 (primary, (→ # 65)). SFD3 can be used only with the special Kollmorgen hybrid cable (CCJ9 or WCJ9 type, see Accessories Manual) (on request).

Maximum cable length 25 m.

FBTYPE: 36

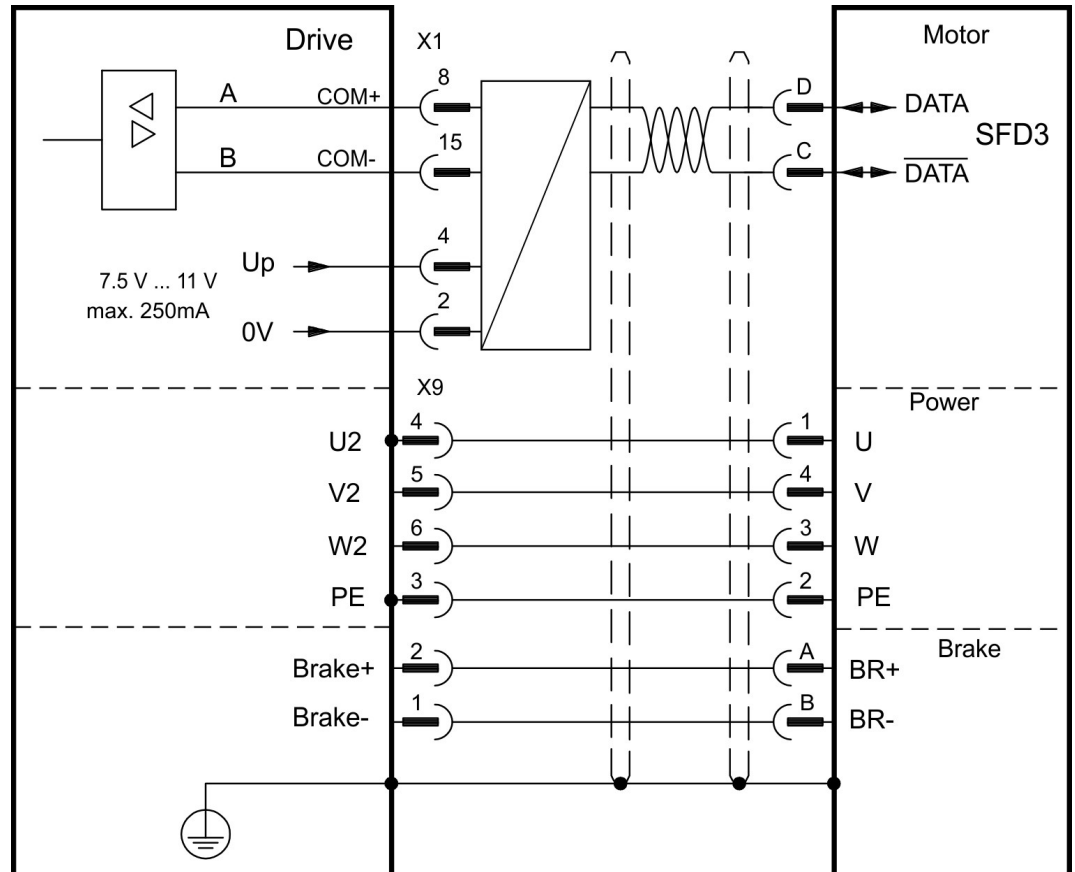

The pin assignment shown on the motor side relates to the AKM motors (connector code D).

9.12.2 HIPERFACE DSL (X1), single cable connection

Connection of HIPERFACE DSL feedback (primary, (→ # 65)). HIPERFACE DSL can be used only with the special Kollmorgen hybrid cable (CCJ9 or WCJ9 type, see Accessories Manual) (on request).

Maximum cable length 25 m.

FBTYPE: 35

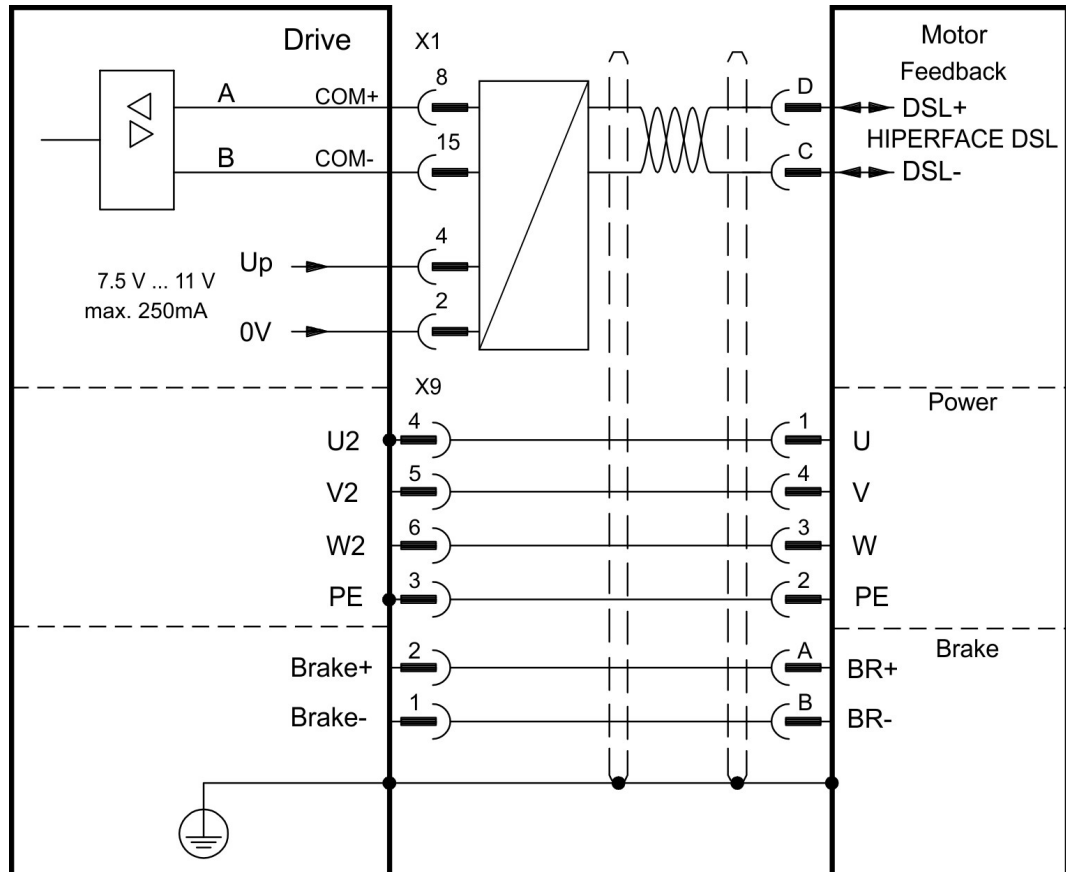

The pin assignment shown on the motor side relates to the AKM motors (connector code D).

9.12.3 Resolver (X2)

Connection of a Resolver (2 to 36-poles) as a feedback system (primary, (→ # 65)). The thermal control in the motor is connected via the resolver cable to X2 and evaluated there. If cable lengths of more than 100 m are planned, please consult our customer service.

FBTYPE: 0

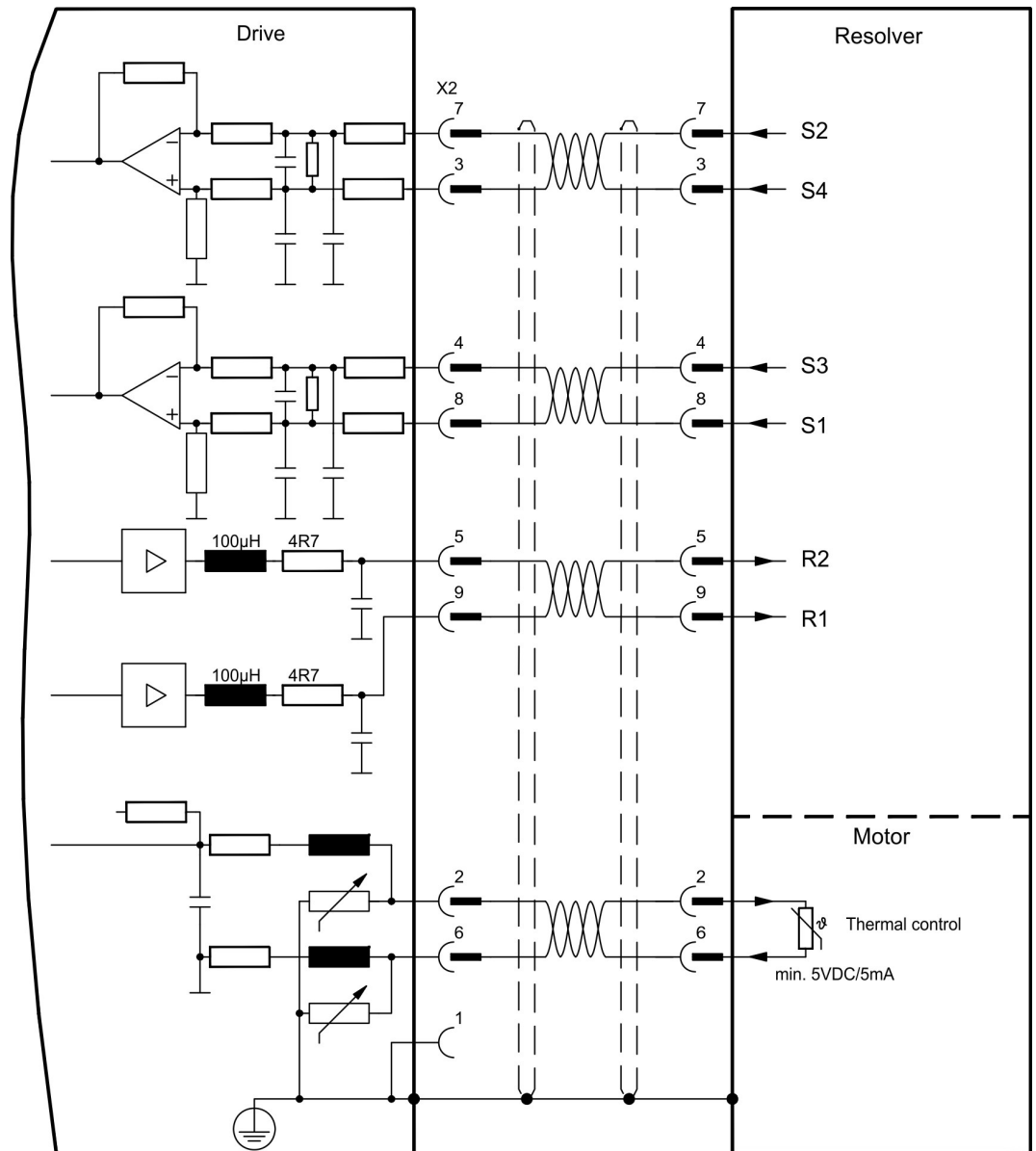

The pin assignment shown on the motor side relates to the AKM motors (connector code D).

9.12.4 Sine Encoder with BiSS analog (X1)

Wiring of a single-turn or multi-turn sine-cosine encoder with BiSS interface as a feedback system (primary and secondary, (→ # 65)).

The thermal control in the motor is connected via the encoder cable to X1 and evaluated there. All signals are connected using our pre-assembled encoder connection cable. If cable lengths of more than 50 m are planned, please consult our customer service.

Frequency limit (sin, cos): 350 kHz

Type	FBTYP	EXTPOS	GEARMODE	Up
5V analog (BiSS B)	23	-	-	5V +/-5%
12V analog (BiSS B)	24	-	-	7.5...11V

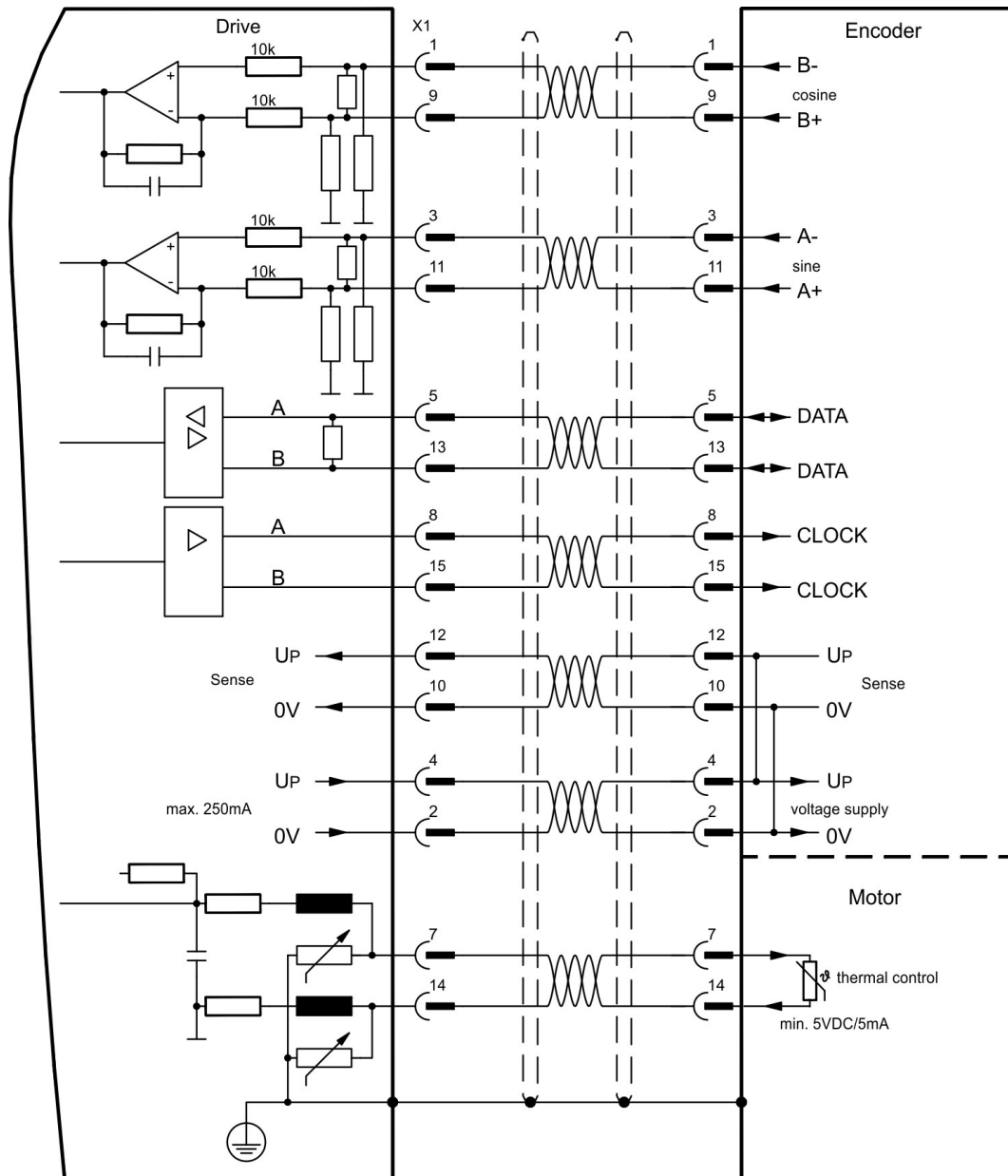

The pin assignment shown on the motor side relates to the AKM motors.

9.12.5 Encoder with BiSS digital (X1)

Wiring of a single-turn or multi-turn digital encoder with BiSS interface as a feedback system (primary and secondary, (→ # 65)).

The thermal control in the motor is connected via the encoder cable to X1 and evaluated there. All signals are connected using our pre-assembled encoder connection cable. If cable lengths of more than 50 m are planned, please consult our customer service.

Frequency limit: 1,5MHz

Type	FBTYPE	EXTPOS	GEARMODE	Up
5V digital (BiSS B)	20	11	11	5V +/-5%
12V digital (BiSS B)	22	11	11	7,5...11V
5V digital (BiSS C, Renishaw)	33	12	12	5V +/-5%

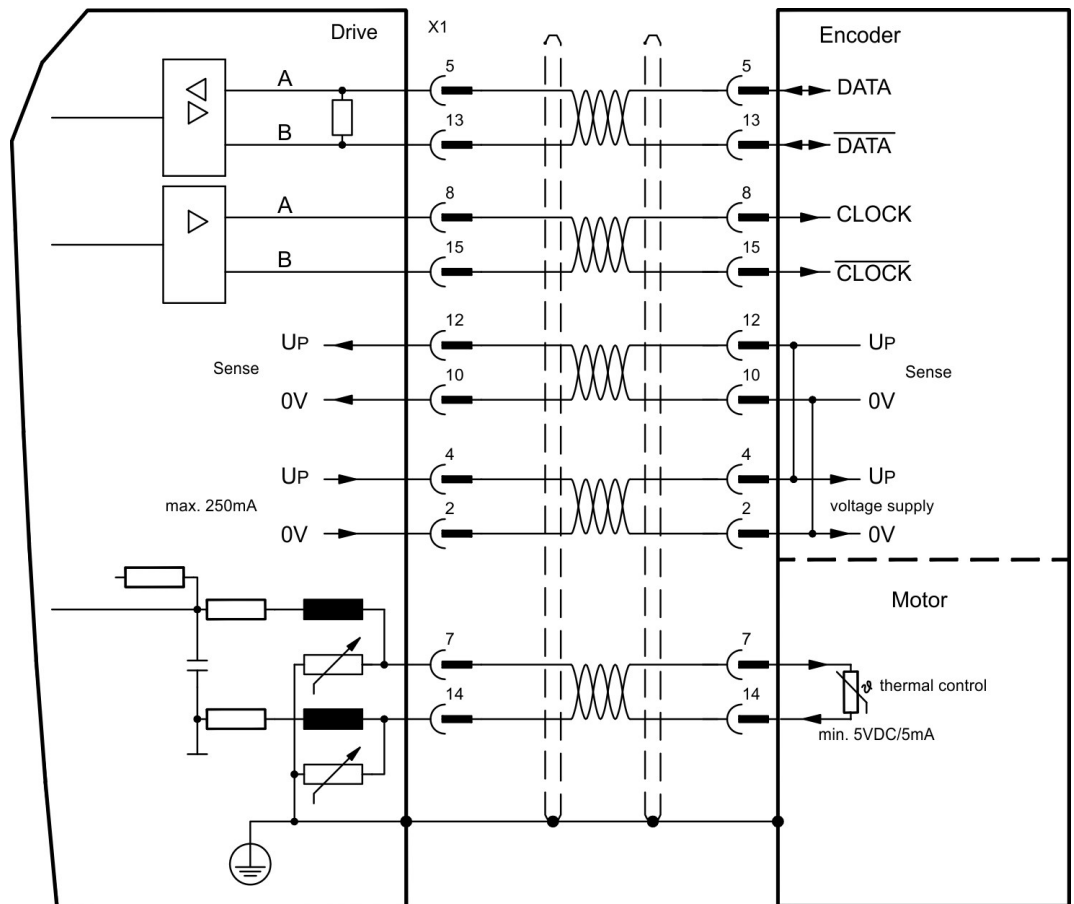

The pin assignment shown on the motor side relates to the AKM motors.

9.12.6 Sine Encoder with EnDat 2.1 (X1)

Wiring of a single-turn or multi-turn sine-cosine encoder with EnDat 2.1 interface as a feed-back system (primary and secondary, (→ # 65)). Preferred types are the optical encoder ECN1313 / EQN1325 and the inductive encoder ECI 1118/1319 or EQI 1130/1331.

The thermal control in the motor is connected via the encoder cable to X1 and evaluated there. All signals are connected using our pre-assembled encoder connection cable. If cable lengths of more than 50 m are planned, please consult our customer service.

Frequency limit (sin, cos): 350 kHz

Type	FBTYPE	EXTPOS	GEARMODE
ENDAT 2.1	4	8	8
ENDAT 2.1 + Wake&Shake	21	8	8

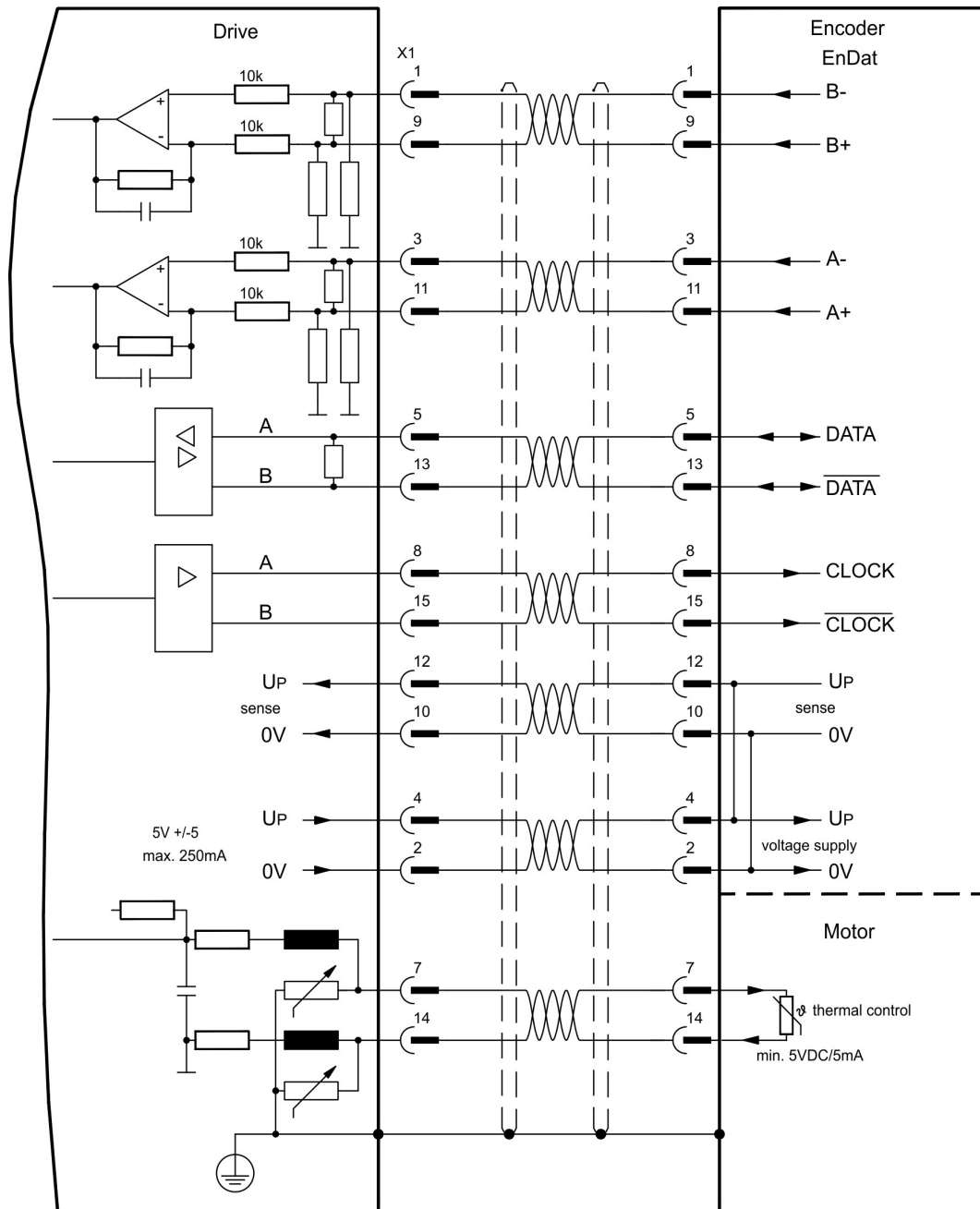

The pin assignment shown on the motor side relates to the AKM motors.

9.12.7 Encoder with EnDat 2.2 (X1)

Wiring of a single-turn or multi-turn encoder with EnDat 2.2 interface as a feedback system (primary, (→ # 65)). The thermal control in the motor is connected via the encoder cable to X1 and evaluated there. All signals are connected using our pre-assembled encoder connection cable.

If cable lengths of more than 50 m are planned, please consult our customer service.

Frequency limit: 1,5MHz

Type	FBTYP	EXTPOS	GEARMODE	Up
5V ENDAT 2.2	32	13	13	5V +/-5%
12V ENDAT 2.2	34	13	13	7,5...11V

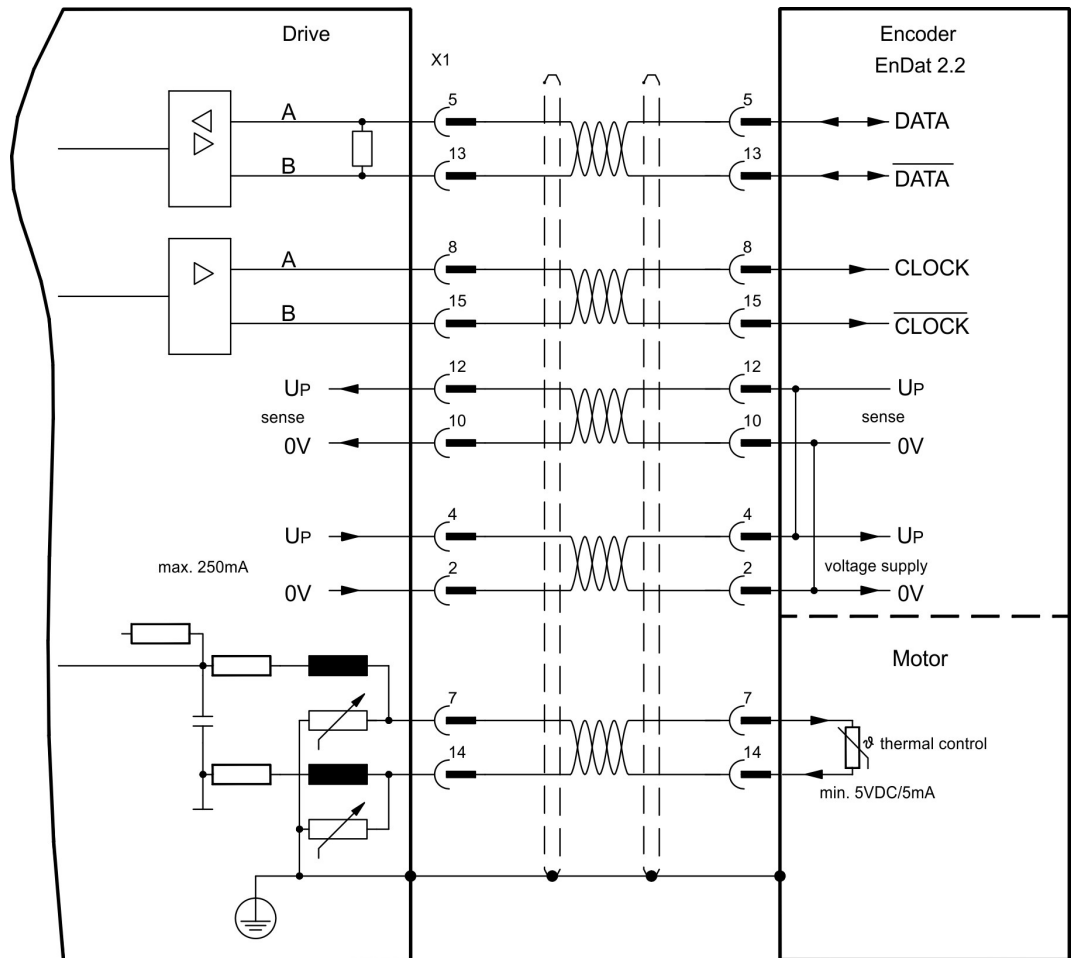

The pin assignment shown on the motor side relates to the AKM motors.

9.12.8 Sine Encoder with HIPERFACE (X1)

Wiring of a single-turn or multi-turn sine-cosine encoder with HIPERFACE interface as a feedback system (primary and secondary, (→ # 65)).

The thermal control in the motor is connected via the encoder cable to X1 and evaluated there.

All signals are connected using our pre-assembled encoder connection cable.

If cable lengths of more than 50 m are planned, please consult our customer service.

Frequency limit (sin, cos): 350 kHz

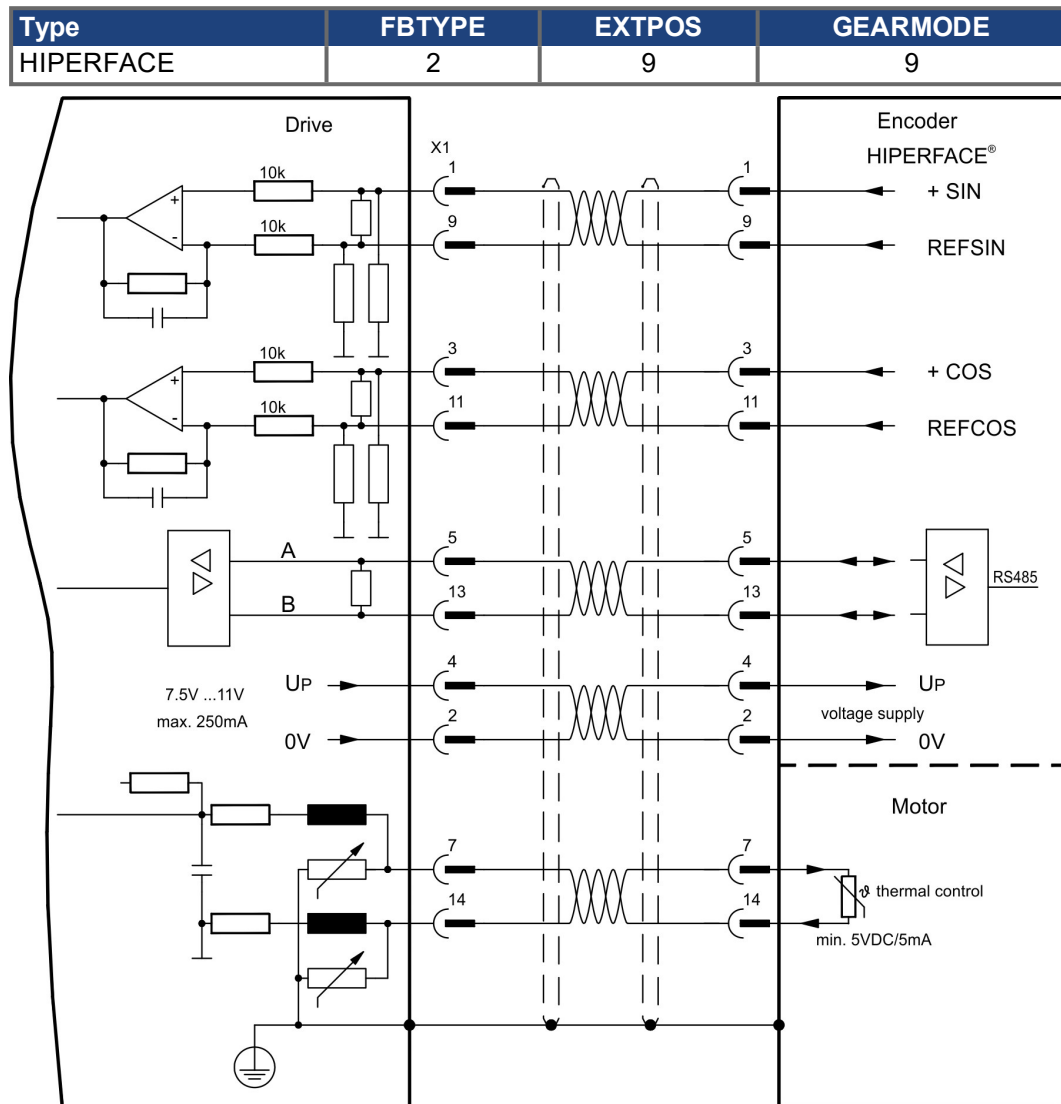

The pin assignment shown on the motor side relates to the AKM motors.

9.12.9 Sine Encoder with SSI (X5, X1)

Wiring of sine-cosine encoder with SSI interface as a linear feedback system (primary, (→ # 65)) to X5.

The thermal control in the motor is connected via the encoder cable to X1 and evaluated there. All signals are connected using our pre-assembled encoder connection cable. If cable lengths of more than 50m are planned, please consult our customer service.

Frequency limit (sin, cos): 350 kHz

Type	FATYPE	EXTPOS	GEARMODE
SinCos SSI 5V linear	28	-	-

Switch on supply voltage for the encoder at X1: set ENCVON to 1

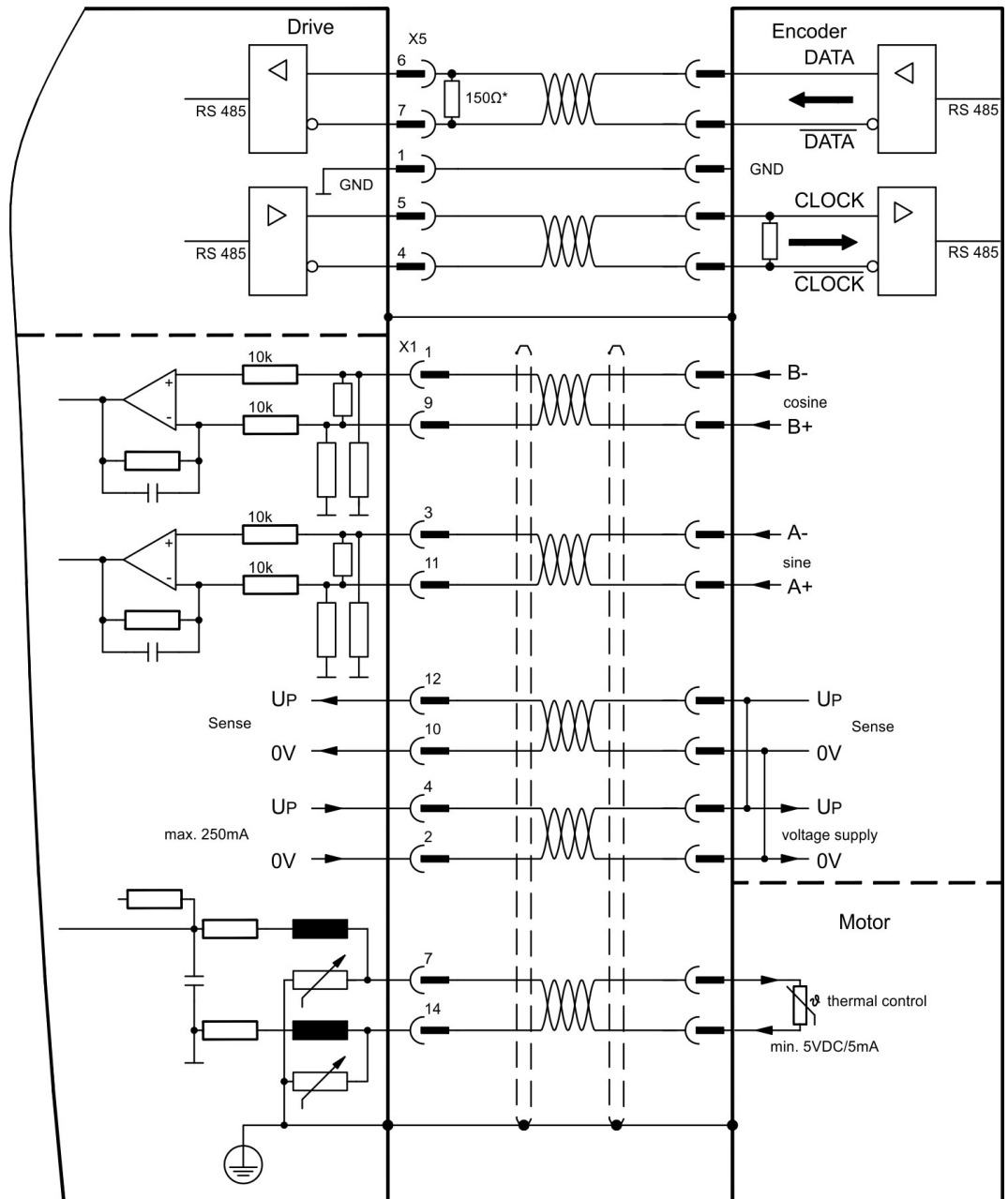

9.12.10 Sine Encoder without data channel (X1)

Wiring of a sine-cosine encoder without data channel as a feedback (primary and secondary, (→ # 65)). Every time the 24V auxiliary voltage is switched on, the amplifier needs start-up information for the position controller (parameter value MPHASE). Depending on the feedback type either wake&shake is executed or the value for MPHASE is read out of the amplifier's EEPROM.



WARNING Vertical load can fall!

With vertical load the load could fall during wake&shake, because the brake is not active and torque is not sufficient to hold the load.

- Don't use wake&shake with vertical load (hanging load).

The thermal control in the motor is connected via the encoder cable to X1. If lead lengths of more than 50 m are planned, please consult our customer service. Frequency limit (sin, cos): 350 kHz

Type	FBTYP	EXTPOS	GEARMODE	Up	Remarks
SinCos 5V	1	6	6	5V +/-5%	MPHASE from EEPROM
SinCos 12V	3	7	7	7.5...11V	MPHASE from EEPROM
SinCos 5V	7	6	6	5V +/-5%	MPHASE wake & shake
SinCos 12V	8	7	7	7.5...11V	MPHASE wake & shake

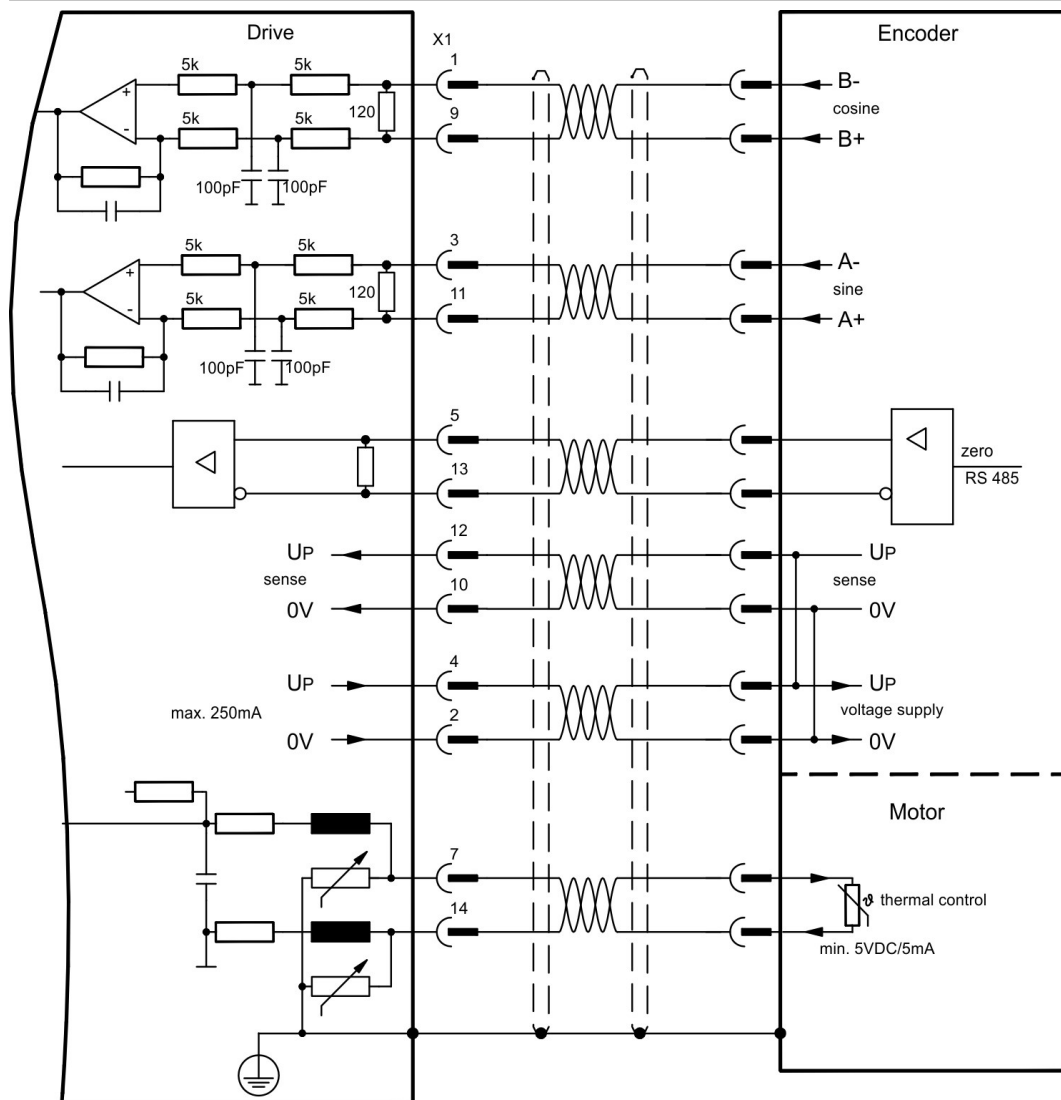

9.12.11 Sine Encoder with Hall (X1)

Feedback devices (incremental or sine-cosine), which don't deliver an absolute information for commutation, can be used as complete feedback system combined with an additional Hall encoder (primary, (→ # 65)).

The thermal control in the motor is connected to X1 and evaluated there.

All signals are connected to X1 and evaluated there. If cable lengths of more than 25 m are planned, please consult our customer service.

Frequency limit (sin, cos): 350 kHz

Type	FBTYP	EXTPOS	GEARMODE	Up
SinCos 5V mit Hall	5	-	-	5V +/-5%
SinCos 12V mit Hall	6	-	-	7.5...11V

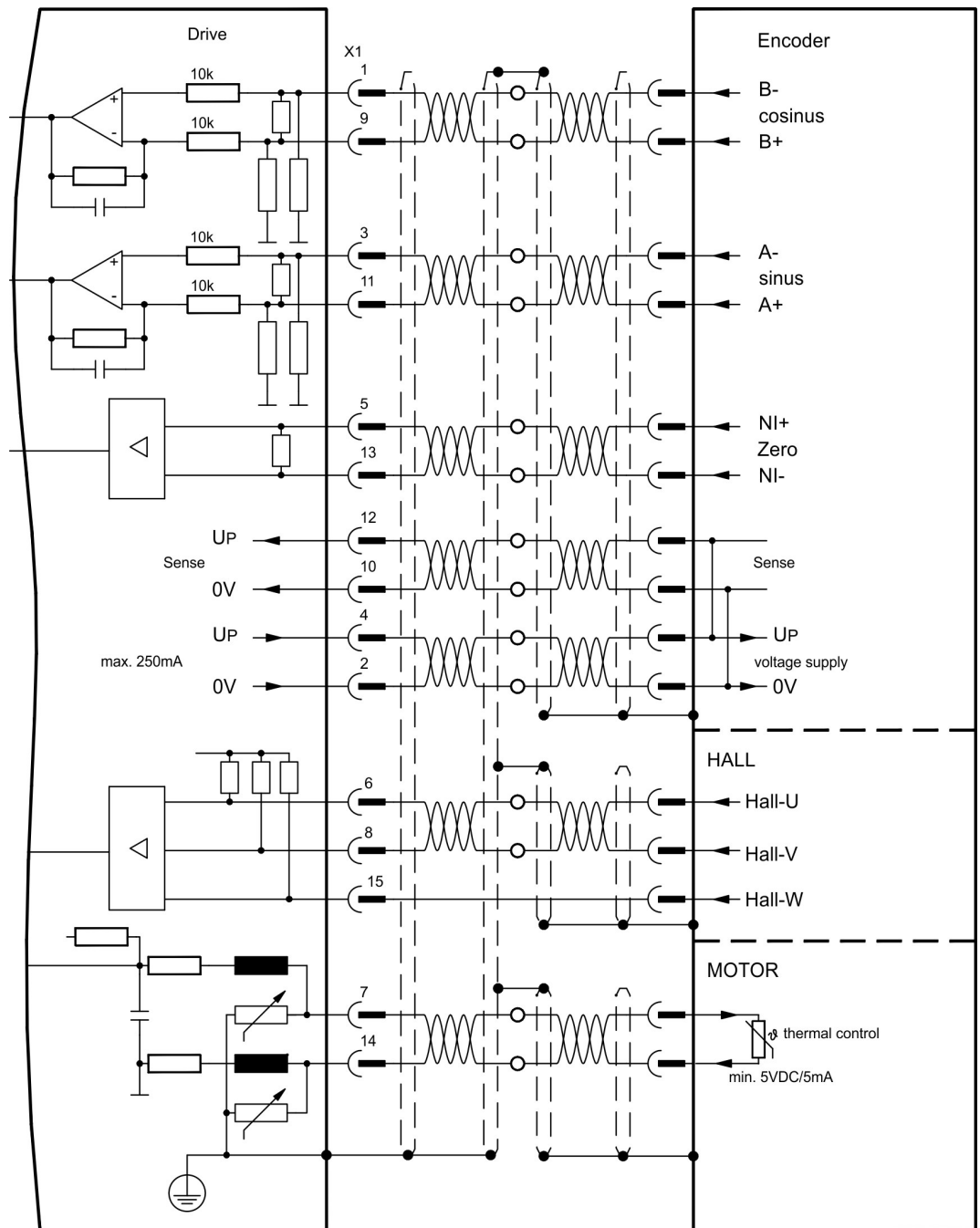

9.12.12 ROD (AquadB) 5V, 1.5MHz (X1)

Wiring of a 5V incremental encoder (ROD, AquadB) as a feedback (primary or secondary, (→ # 65)). Every time the 24V auxiliary voltage is switched on, the amplifier need start-up information for the position controller (parameter value MPHASE). Depending on the setting of FBTYPE a wake&shake is executed or the value for MPHASE is taken out of the servo amplifier's EEPROM.



WARNING Vertical load can fall!

With vertical load the load could fall during wake&shake, because the brake is not active and torque is not sufficient to hold the load.

- Don't use wake&shake with vertical load (hanging load).

The thermal control in the motor is connected via the encoder cable to X1. All signals are connected using our pre-assembled encoder connection cable. If cable lengths of more than 50 m are planned, please consult our customer service.

Frequency limit (A, B): 1,5MHz

Type	FBTYPE	EXTPOS	GEARMODE	Remarks
AquadB 5V	31	30	30	MPHASE from EEPROM
AquadB 5V	30	30	30	MPHASE with wake & shake

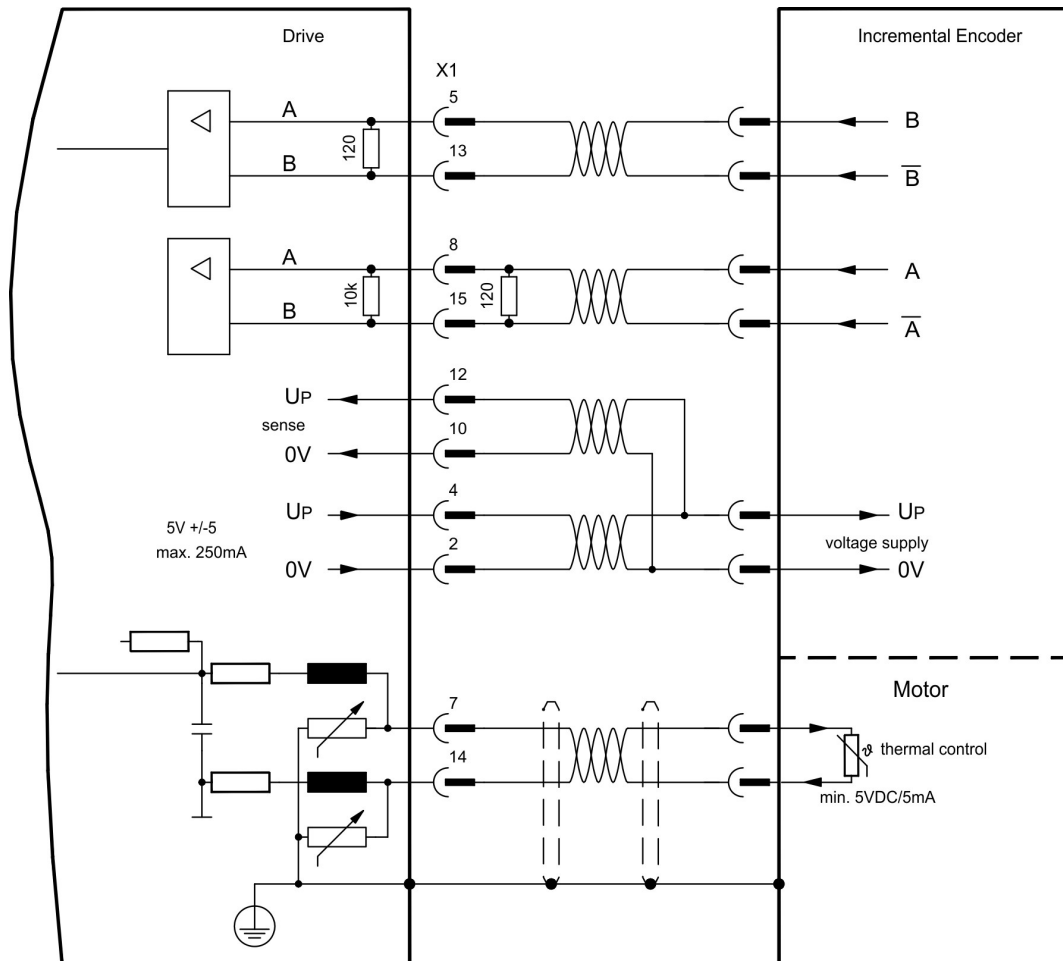

9.12.13 ROD (AquadB) 5V, 350kHz (X1)

Wiring of a 5V incremental encoder (ROD, AquadB) as a feedback (primary or secondary, (→ # 65)). Every time the 24V auxiliary voltage is switched on, the amplifier need start-up information for the position controller (parameter value MPHASE). Depending on the setting of FBTYPE a wake&shake is executed or the value for MPHASE is taken out of the servo amplifier's EEPROM.



⚠ WARNING Vertical load can fall!

With vertical load the load could fall during wake&shake, because the brake is not active and torque is not sufficient to hold the load.

- Don't use wake&shake with vertical load (hanging load).

The thermal control in the motor is connected to X1. If lead lengths of more than 50 m are planned, please consult our customer service. Frequency limit (A, B): 350 kHz

Type	FBTYPE	EXTPOS	GEARMODE	Remarks
AquadB 5V	27	10	10	MPHASE from EEPROM
AquadB 5V	17	10	10	MPHASE with wake & shake

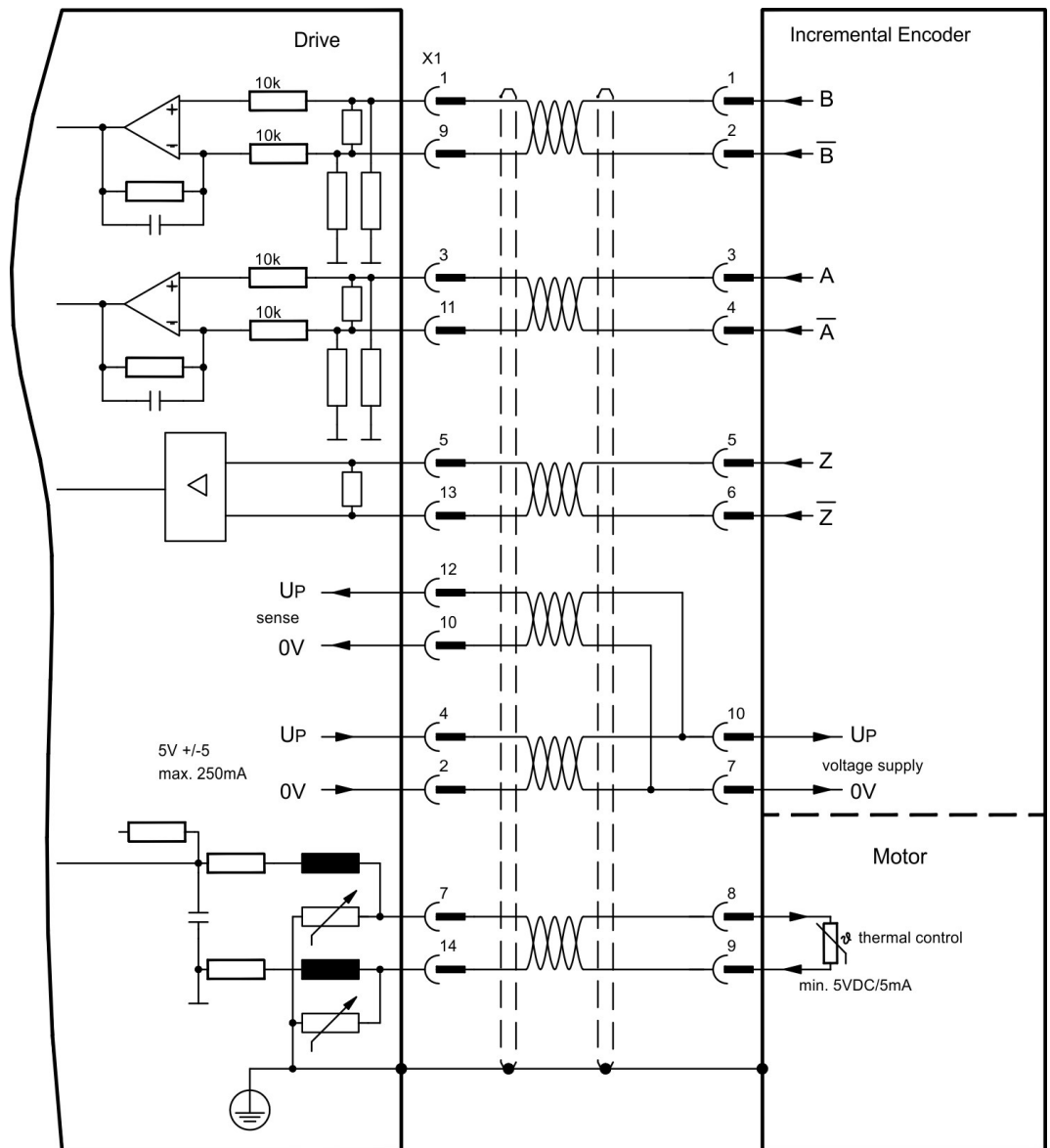

The pin assignment shown on the motor side relates to the AKM motors.

9.12.14 ROD (AquadB) 5V, 350kHz with Hall (X1)

Wiring of a ComCoder as a feedback unit (primary, (→ # 65)). For the commutation hall sensors are used and for the resolution an incremental encoder.

The thermal control in the motor is connected to X1 and evaluated there. With our ComCoder cable all signals are connected correctly. If cable lengths of more than 25 m are planned, please consult our customer service. With separate feedback devices (Encoder and Hall are two devices) the wiring must be done similar to (→ # 77), but the amplifier's pinout is identical to the wiring diagram shown below.

Frequency limit (A,B): 350 kHz

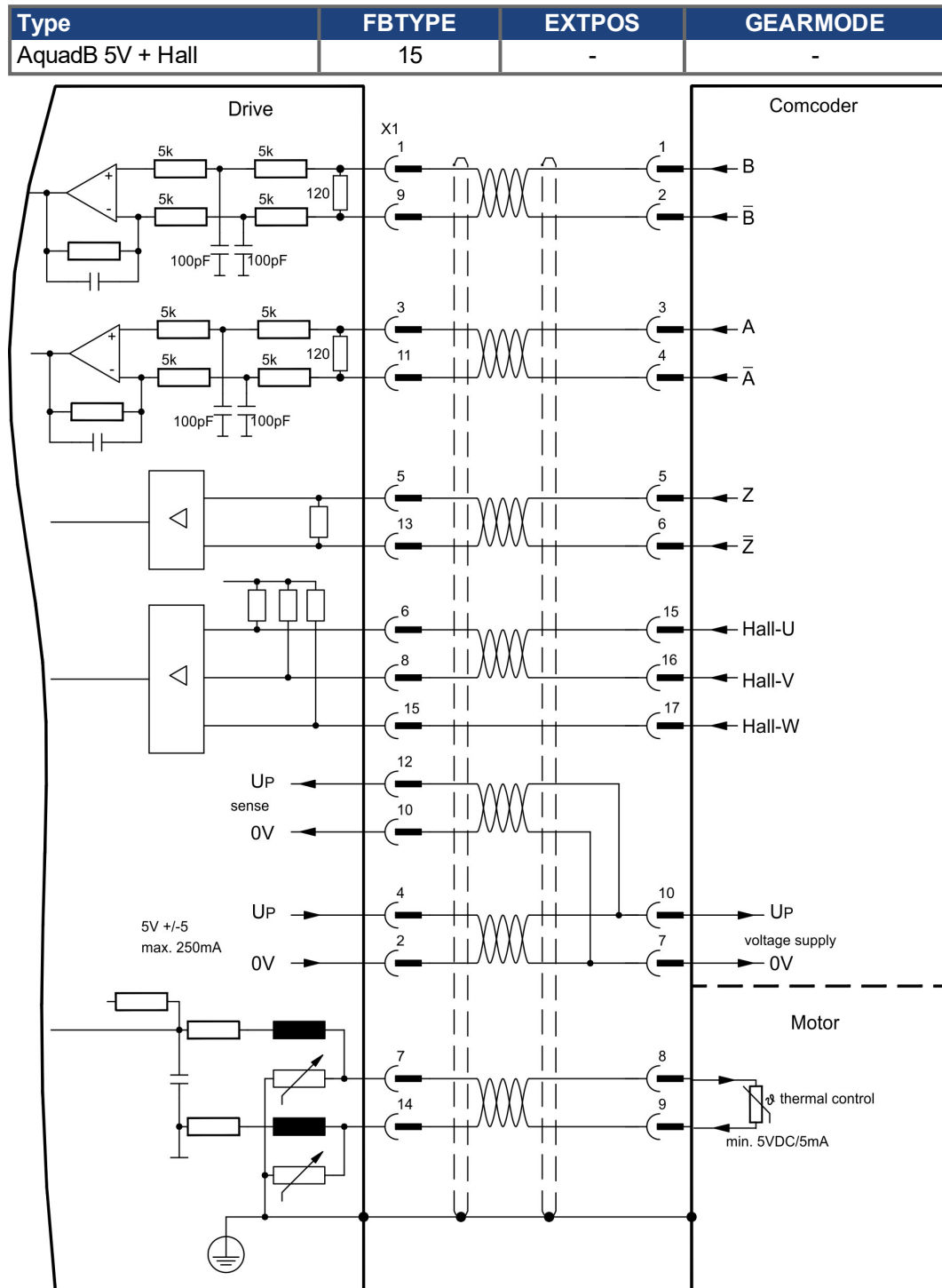

The pin assignment shown on the motor side relates to the AKM motors.

9.12.15 ROD (AquadB) 5V (X5, X1)

A 5V incremental encoder (AquadB) can be used as standard motor feedback (primary and secondary (→ # 66)). Every time the 24V auxiliary voltage is switched on, the amplifier need start-up information for the position controller (parameter value MPHASE). Depending on the feedback type either Wake&Shake is executed or the value for MPHASE is read out of the amplifier's EEPROM.



⚠ WARNING Vertical load can fall!

With vertical load the load could fall during wake&shake, because the brake is not active and torque is not sufficient to hold the load.

- Don't use wake&shake with vertical load (hanging load).

The thermal control in the motor is connected to X1. If lead lengths of more than 50 m are planned please consult our customer service. Frequency limit (A, B, N): 1.5 MHz

Type	FATYPE	EXTPOS/Gearmode	ENCMODE	Remarks
AquadB 5V	13	3	0	MPHASE EEPROM
AquadB 5V	19	3	0	MPHASE wake&shake

Switch on supply voltage for the encoder at X1: set ENCVON to 1.

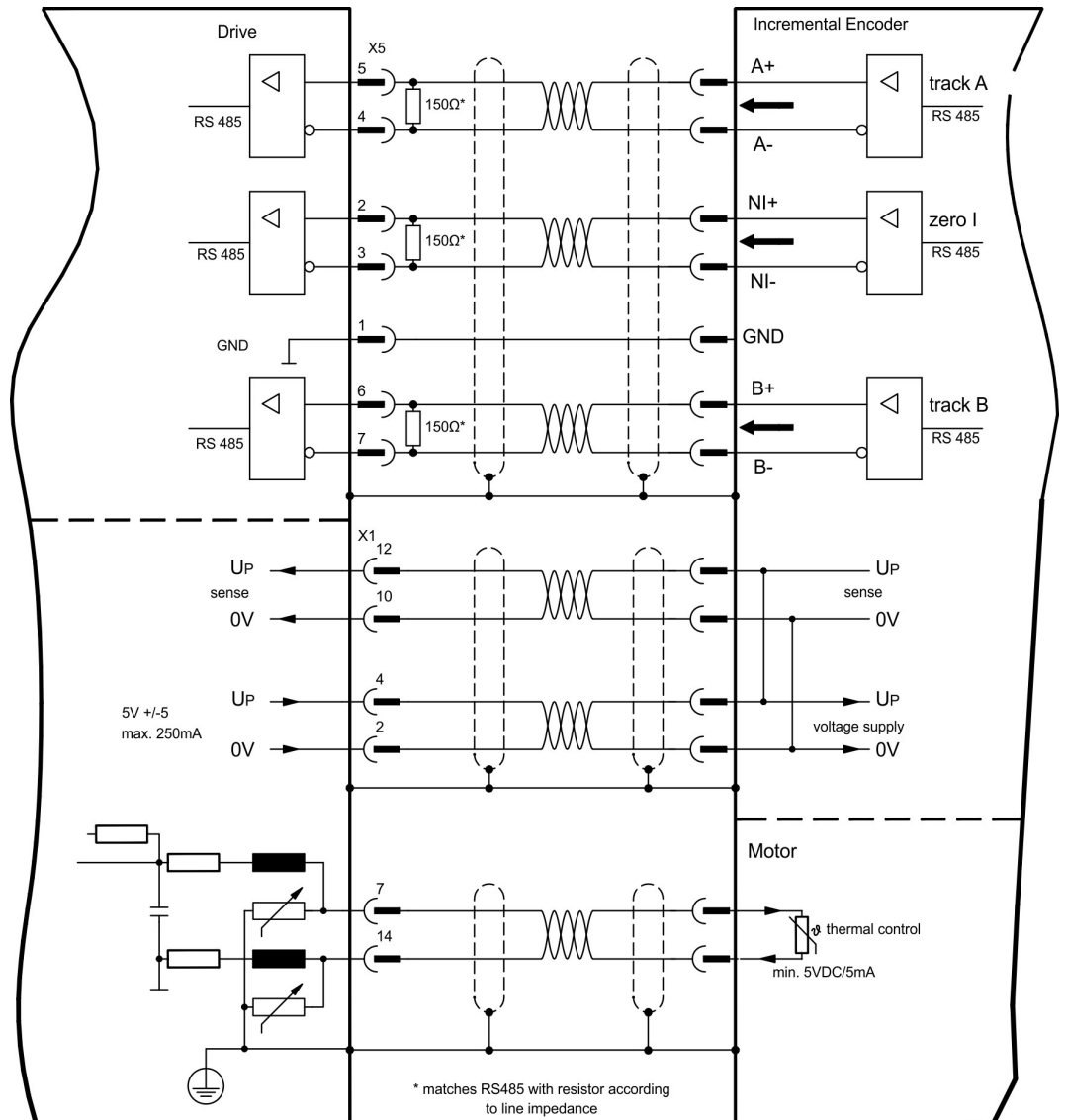

9.12.16 ROD (AquadB) 5V with Hall (X5, X1)

Wiring of a 5V incremental encoder (ROD, AquadB) with Hall sensors as a feedback unit (primary, (→ # 66)). For the commutation hall sensors are used and for the resolution an incremental encoder.

Voltage supply and the thermal control in the motor is connected to X1.

If cable lengths of more than 25 m are planned, please consult our customer service.

Frequency limit X5: 1.5 MHz, X1: 350 kHz

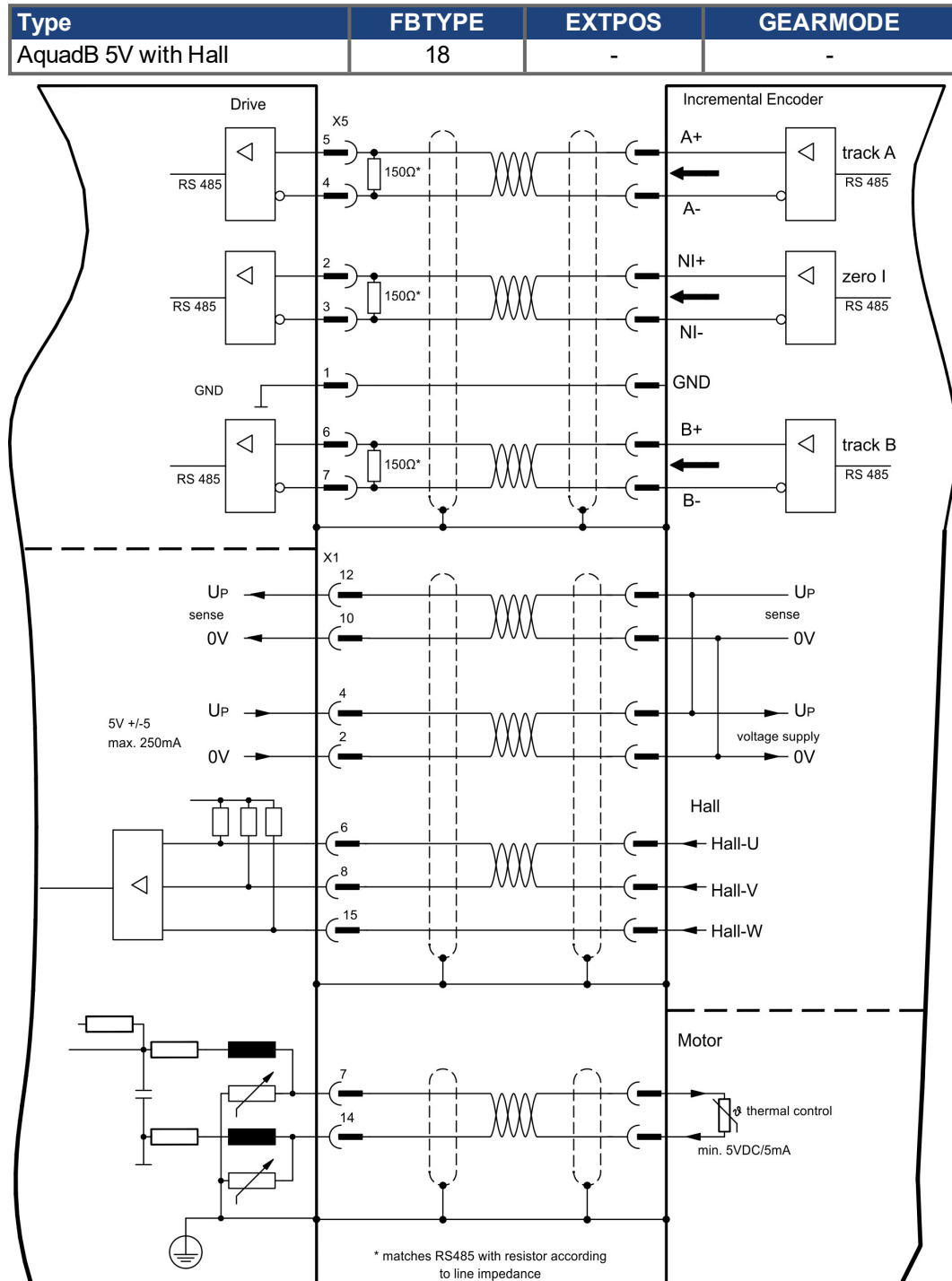

9.12.17 ROD (AquadB) 24V (X3)

Wiring of a 24V incremental encoder (ROD AquadB) as a feedback system (primary or secondary, (→ # 65)). This uses the digital inputs DIGITAL-IN 1 and 2 on connector X3.

Every time the 24V auxiliary voltage is switched on, the amplifier need start-up information for the position controller (parameter value MPHASE). Depending on the setting of FBTYPE a wake&shake is executed or the value for MPHASE is taken out of the servo amplifier's EEPROM.



WARNING Vertical load can fall!

With vertical load the load could fall during wake&shake, because the brake is not active and torque is not sufficient to hold the load.

- Don't use wake&shake with vertical load (hanging load).

The thermal control in the motor is connected to X1 or X2. If cable lengths of more than 25 m are planned, please consult our customer service.

Frequency limit: 100 kHz, transition time $t_v \leq 0.1\mu s$

Type	FBTYPE	EXTPOS	GEARMODE	Remarks
AquadB 24V	12	2	2	MPHASE from EEPROM
AquadB 24V	16	2	2	MPHASE with wake & shake

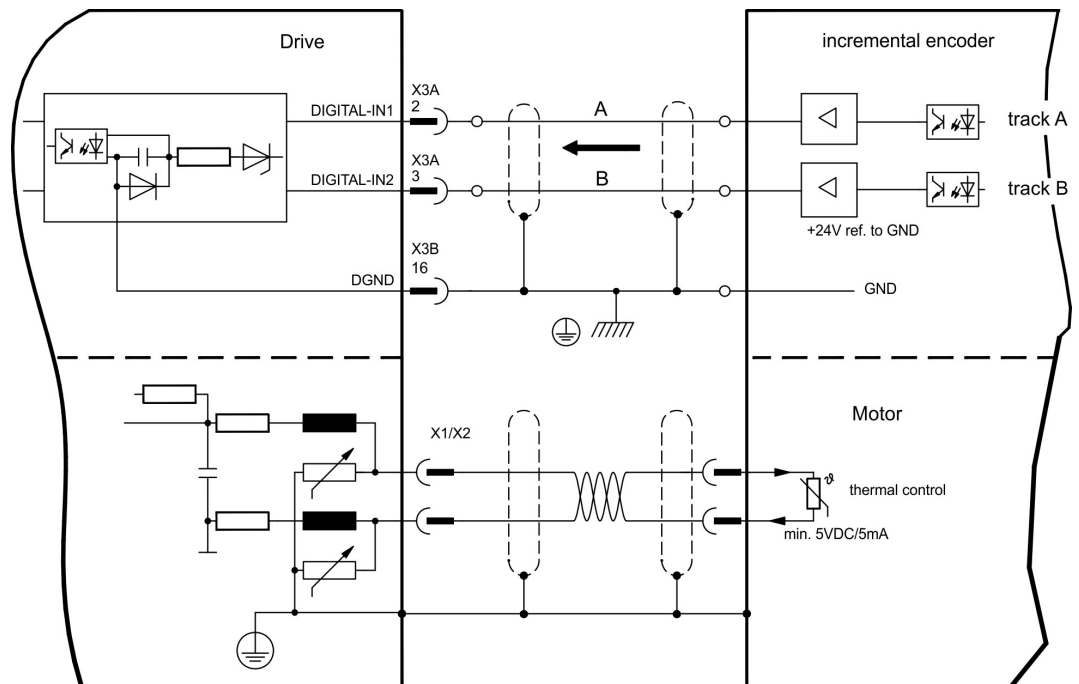

9.12.18 ROD (AquadB) 24V with Hall (X3, X1)

Wiring of a 24V incremental encoder (ROD, AquadB) and Hall sensors as a feedback unit (primary, (→ # 65)). For the commutation hall sensors are used and for the resolution an incremental encoder.

The thermal control in the motor is connected to X1 and evaluated there. If cable lengths of more than 25 m are planned, please consult our customer service.

Frequency limit X3: 100 kHz, X1: 350 kHz

Type	FBTYPE	EXTPOS	GEARMODE
AquadB 24V + Hall	14	-	-

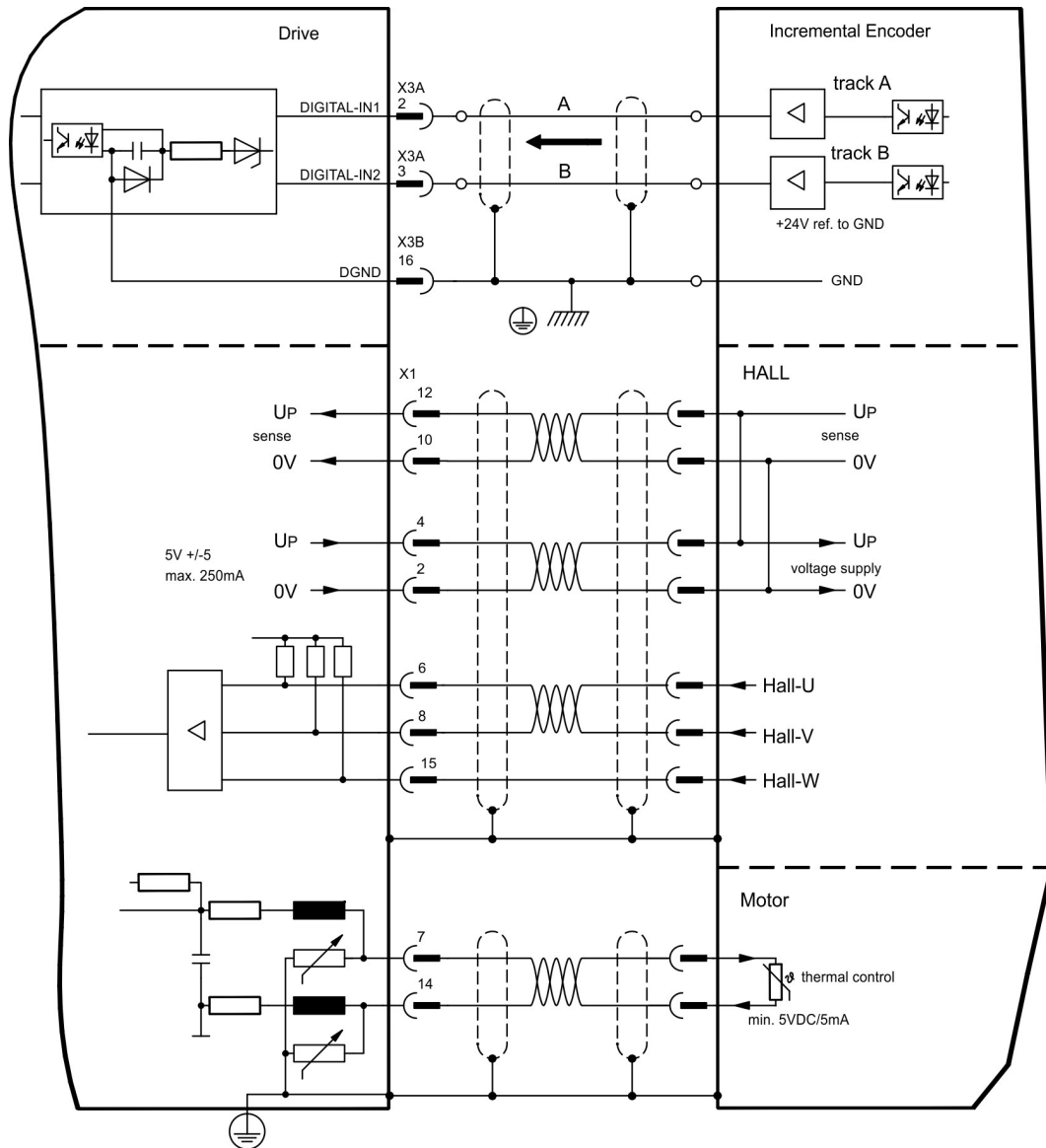

9.12.19 SSI Encoder (X5, X1)

Wiring of a synchronous serial absolute encoder as a feedback system (primary or secondary, (→ # 65)). The signal sequence can be read in Gray code or in Binary (standard) code.

The thermal control in the motor is connected to X1 and evaluated there. If cable lengths of more than 50m are planned, please consult our customer service.

Frequency limit: 1.5MHz

Type	FBTYP	EXTPOS	GEARMODE
SSI	9	5	5

Switch on supply voltage for the encoder at X1: set ENCVON to 1.

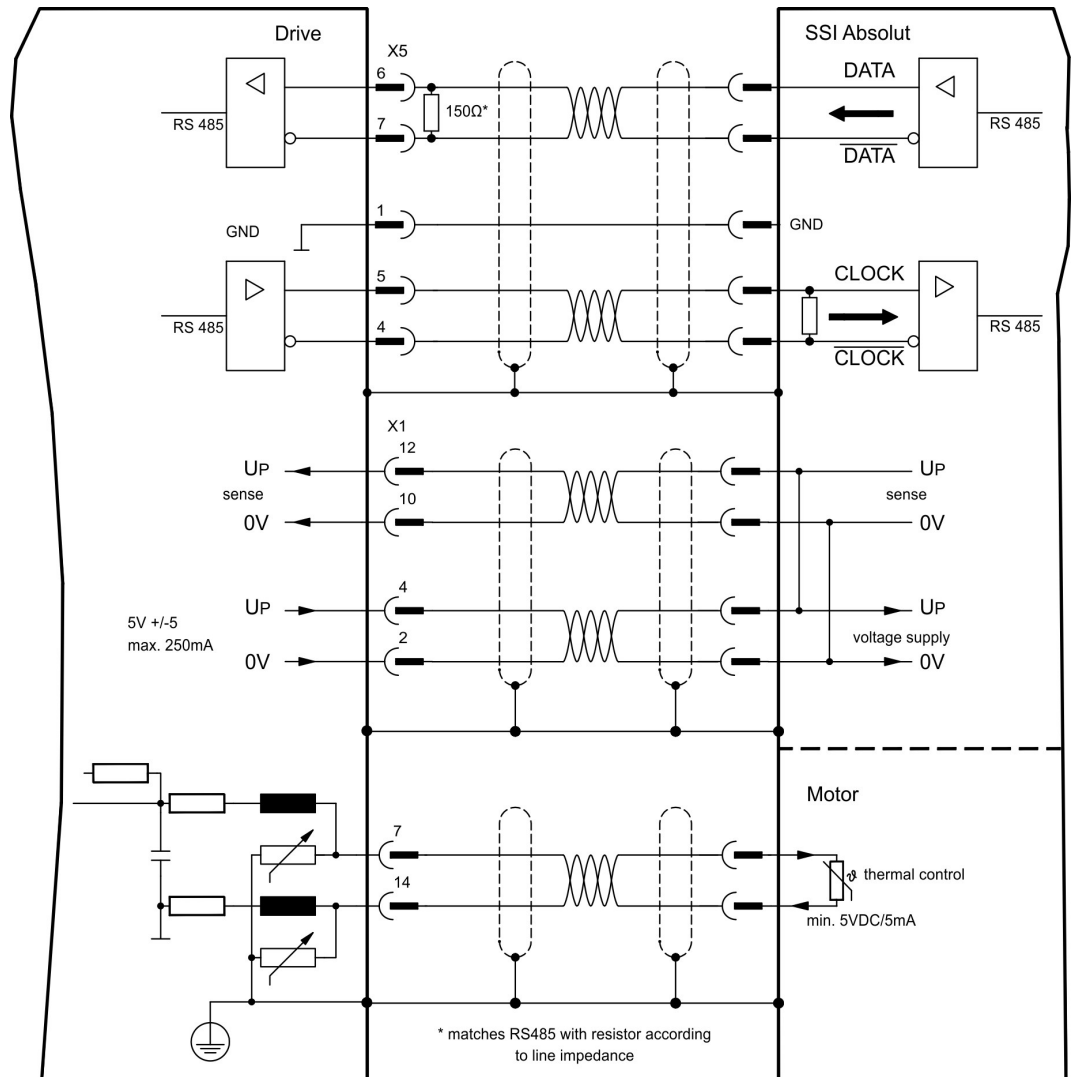

9.12.20 Hall sensors (X1)

Wiring of Hall sensors as a feedback unit (primary, (→ # 65)).

The thermal control in the motor is connected to X1 and evaluated there. If cable lengths of more than 25 m are planned, please consult our customer service.

Frequency limit: 350 kHz

Type	FBTYP	EXTPOS	GEARMODE
Hall	11	-	-

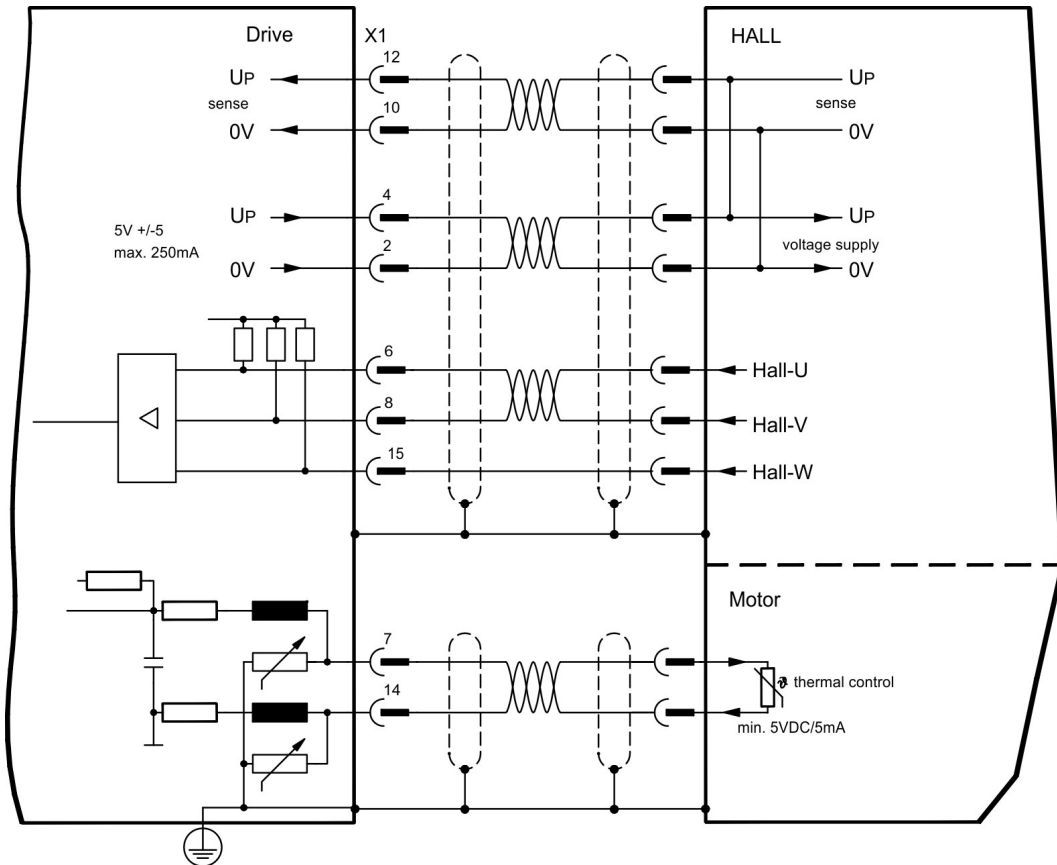

9.13 Electronic Gearing, Master-Slave operation

In the case of the “electronic gearing” functionality (see setup software and description of GEARMODE parameter), the servo amplifier is controlled by a secondary feedback device as a slave.

It is possible to set up master/slave systems, use an external encoder as a setpoint encoder or connect the amplifier to a stepper motor control.

The amplifier is parameterized using the setup software (electronic gearing, parameter GEARMODE).

The resolution (number of pulses per revolution) can be adjusted.

NOTE

If input X1 is used without the X1 power supply (pins 2, 4, 10, 12), e.g. master-slave operation with other servoamplifiers, the monitoring of this power supply must be switched off in order to prevent error message F04 from appearing. To do this, you must change Bit 20 of the DRVCFG2 parameter (see ASCII object reference in the online help).

9.13.1 Encoder control types

The following types of external encoder can be used for control:

S300 controlled by	Frequency limit	Connector	Wiring diagram	GEARMODE
Encoder BiSS digital	1,5 MHz	X1	(→ #71)	11, 12
SinCos Encoder ENDAT 2.1	350 kHz	X1	(→ #72)	8
Encoder ENDAT 2.2	1,5 MHz	X1	(→ #73)	13
SinCos Encoder HIPERFACE	350 kHz	X1	(→ #74)	9
SinCos Encoder without data channel	350 kHz	X1	(→ #76)	6, 7
Incr. Encoder (AquadB) 5V	1,5 MHz	X1	(→ #78)	30
Incr. Encoder (AquadB) 5V	350 kHz	X1	(→ #79)	10
Incr. Encoder (AquadB) 5V	1,5 MHz	X5, X1	(→ #81)	3
Incr. Encoder (AquadB) 24V	100 kHz	X3	(→ #83)	2
SSI 5V	1,5 MHz	X5, X1	(→ #85)	5
Step/direction 5V	1,5 MHz	X1	(→ #88)	27
Step/direction 5V	1,5 MHz	X5, X1	(→ #88)	4
Step/direction 24V	100 kHz	X3	(→ #88)	1

9.13.2 Connection to stepper motor controllers (step and direction)

You can connect the servo amplifier to a third-party stepper-motor controller. Parameter setting for the slave amplifier is carried out with the aid of the setup software (electronic gearing). The number of steps can be adjusted, so that the servo amplifier can be adapted to match the step-direction signals of any stepper controller. Various monitoring signals can be generated.

NOTE Using an A quad B encoder provides better EMC noise immunity.

9.13.2.1 Step / Direction with 5 V signal level (X1)

Wiring of the servo amplifier (SubD connector X1) to a stepper-motor controller with a 5V signal level.

Frequency limit: 1.5 MHz

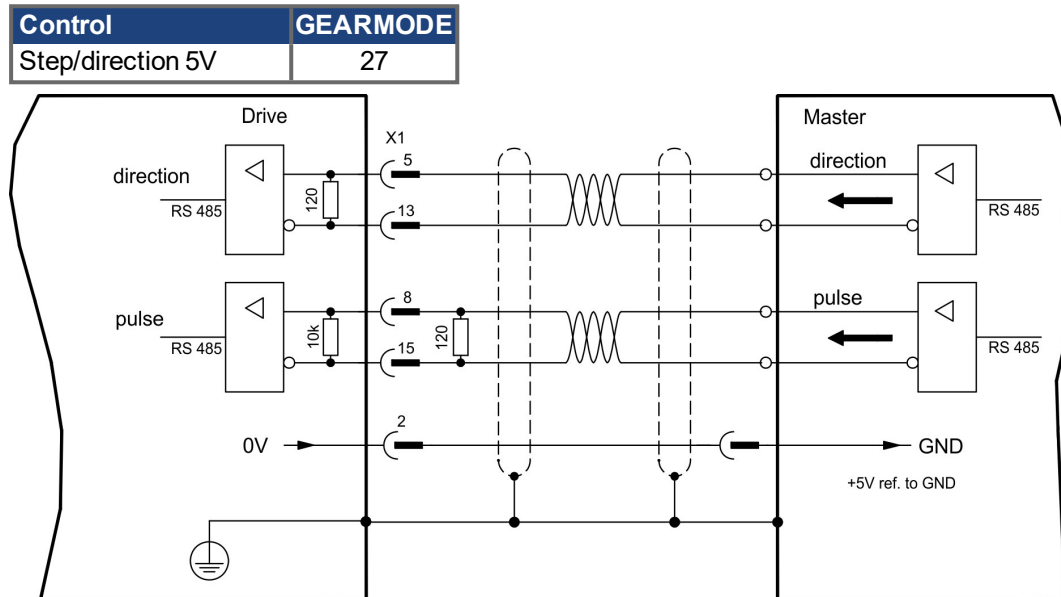

9.13.2.2 Step / Direction with 24 V signal level (X3)

Wiring of the servo amplifier to a stepper-motor controller with a 24 V signal level. The digital inputs DIGITAL-IN 1 and 2 on connector X3 are used.

Frequency limit: 100 kHz

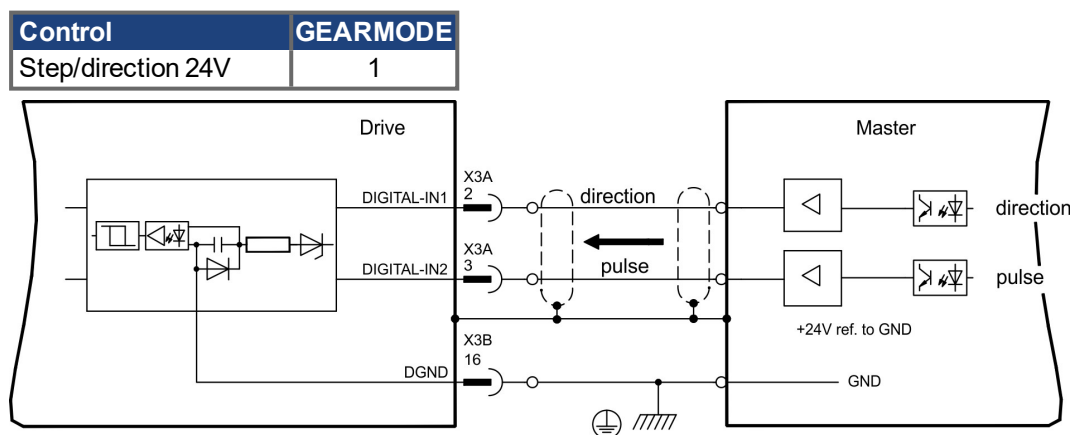

9.13.2.3 Step / Direction with 5 V signal level (X5)

Wiring of the servo amplifier (SubD connector X5) to a stepper-motor controller with a 5 V signal level.

Frequency limit: 1,5 MHz

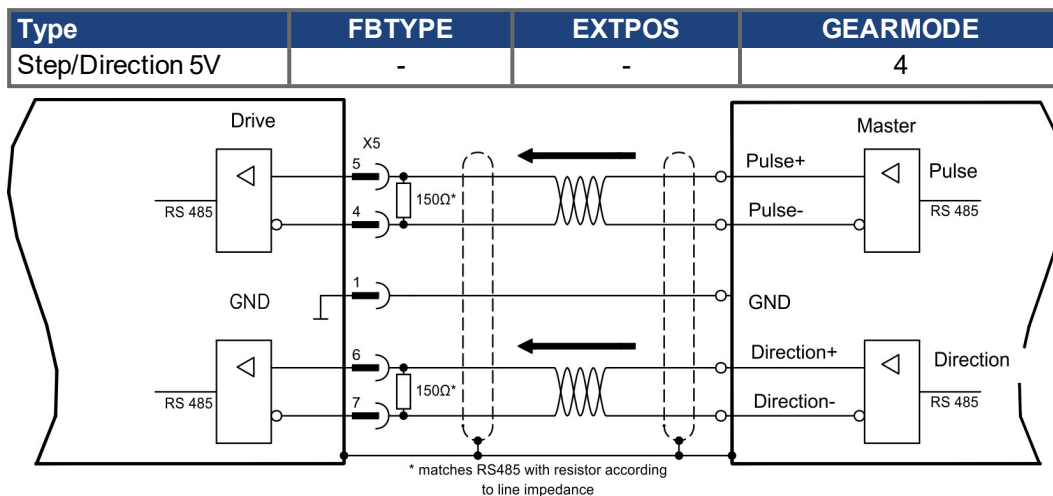

9.13.3 Anschluss für Master-Slave Betrieb

You can, for example, link several S300 amplifiers together in master-slave operation. Up to 16 slave amplifiers can be controlled by the master, via the encoder output.

9.13.3.1 Master-Slave 5V (X1)

Functionality not available.

9.13.3.2 Master-Slave 5V (X5)

Master: position output to X5 (screen page "Encoder emulation")

Slave: screen page "Electronic gearing" (GEARMODE)

Frequency limit X5: 1,5 MHz

Example for Master-Slave operation with two S300 amplifiers (ROD emulation):

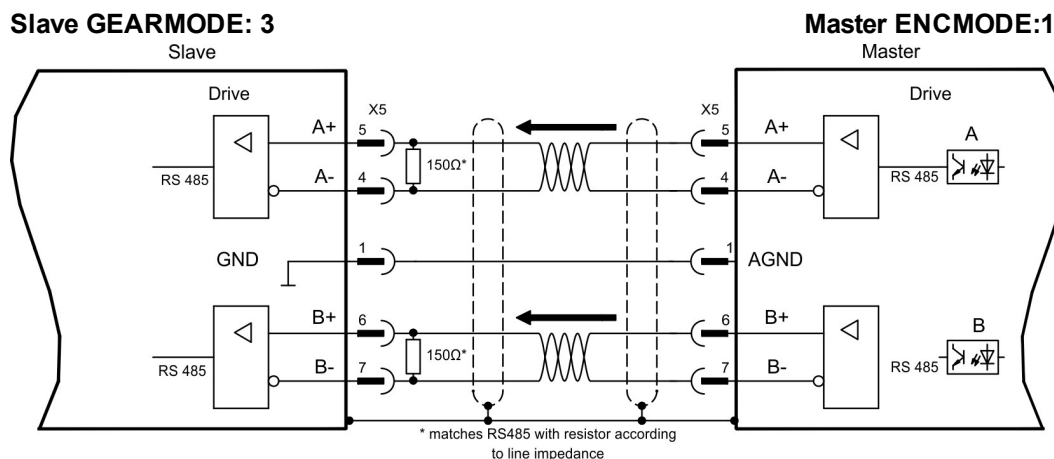

9.14 Encoder Emulation, position output

9.14.1 Incremental encoder output (AquadB) (X5)

The incremental-encoder interface is part of the standard package. Select encoder function ROD (A Quad B) Encoder (“Encoder Emulation” screen page). The servo amplifier calculates the motor shaft position from the cyclic- absolute signals of the resolver or encoder, generating incremental-encoder compatible pulses from this information. Pulse outputs on the SubD connector X5 are 2 signals, A and B, with 90° phase difference (i.e. in quadrature, hence the alternative term “A quad B” output), with a zero pulse.

The resolution (before multiplication) can be set:

Encoder function (ENCMODE)	Feedback system (FBTYPE)	Resolution (lines) (ENCOUT)	Zero pulse (NI)
1, ROD	0, Resolver	32...4096	once per turn (only at A=B=1)
	2, 4 Encoder	256...524288 ($2^8 \dots 2^{19}$)	
3, ROD Interpolation	Encoder	$2^4 \dots 2^7$ (multiplication) TTL line x encoder resolution	encoder signal passed through from X1 to X5

Use the NI-OFFSET parameter to adjust and save the zero pulse position within one mechanical turn. The drivers operate off an internal supply voltage.

NOTE

The maximum permissible cable length is 100 meters.

Connections and signals for the incremental encoder interface :

Default count direction: UP when motor shaft is rotating clockwise (looking at shaft's end)

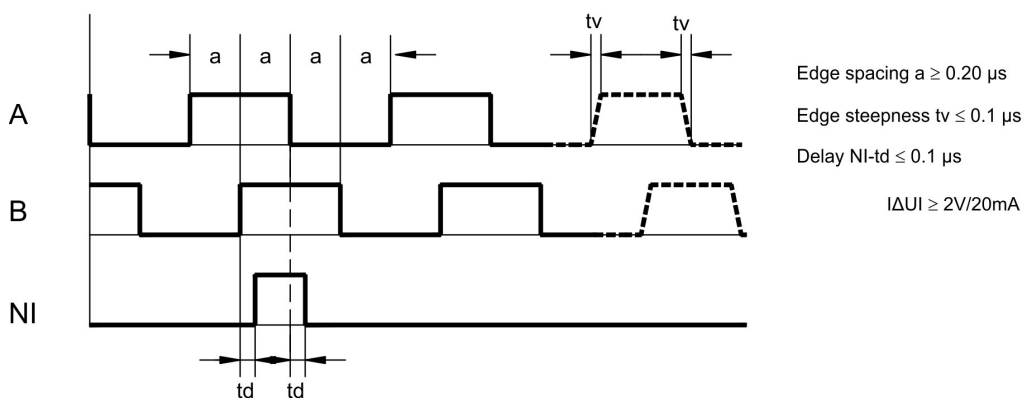
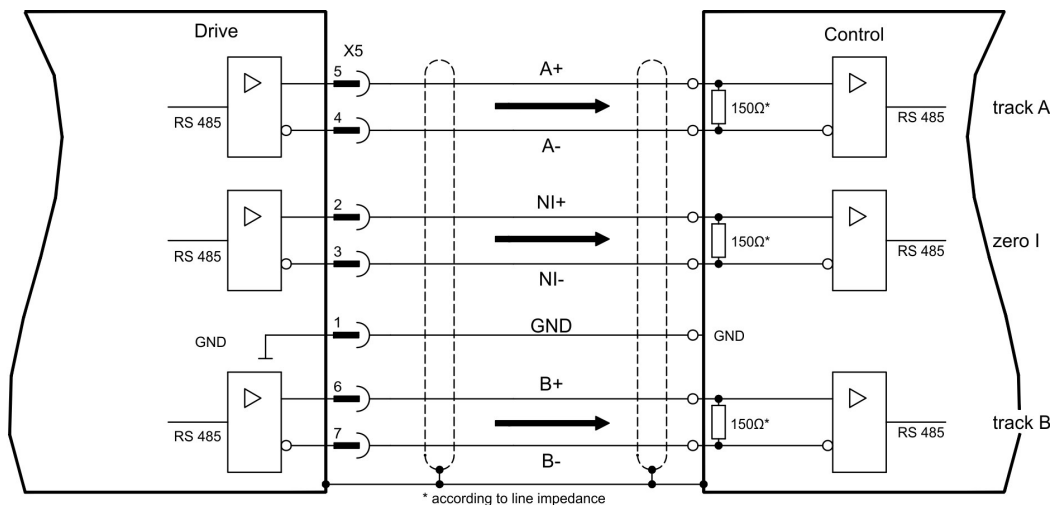

9.14.2 SSI encoder output (X5)

The SSI interface (synchronous serial absolute-encoder emulation) is part of the standard package. Select encoder function SSI ("Encoder Emulation" screen page, ENCMODE 2). The servo amplifier calculates the motor shaft position from the cyclic-absolute signals of the resolver or encoder. From this information a SSI date (Stegmann patent specification DE 3445617C2) is provided. Max 32 bits are transferred.

The leading data bit contains the number of revolutions and are selectable from 12 to 16 bits. The following max. 16 bits contain the resolution and are not variable.

The following table shows the allocation of the SSI date depending upon selected number of revolutions:

Revolution																Resolution (variable)															
SSIREVOL																															
15	14	13	12	11	10	9	8	7	6	5	4	3	2	1	0	15	14	13	12	11	10	9	8	7	6	5	4	3	2	1	0

The signal sequence can be output in **Gray** code or in **Binary** (standard) code. The servo amplifier can be adjusted to the clock frequency of your SSI-evaluation with the setup software.

The drivers operate off an internal supply voltage.

Connection and signals for the SSI interface :

Default count direction: UP when motor shaft is rotating clockwise (looking at shaft's end)

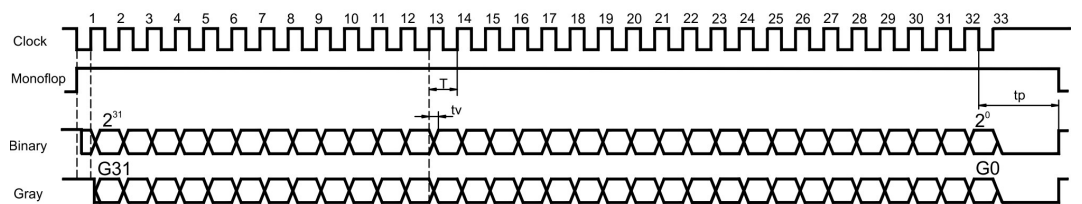
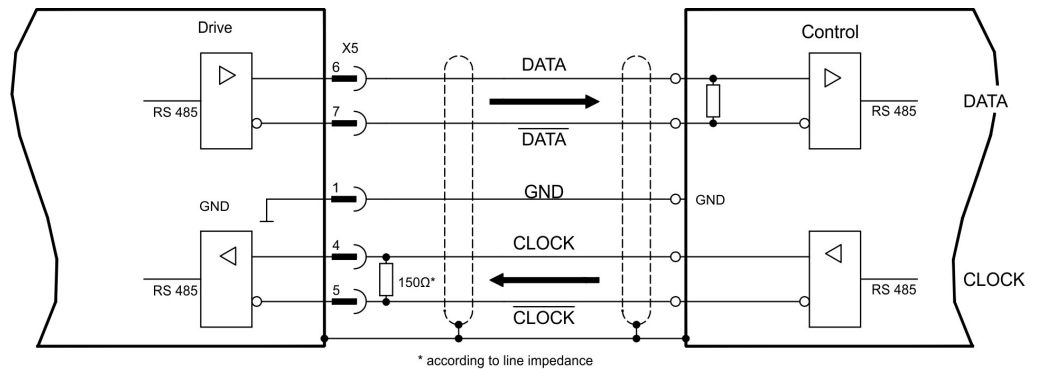

Switch over time Data $t_v \leq 300\text{nsec}$
 Period $T = 600\text{ ns}$
 Time Out $t_p = 3\mu\text{s}/13\mu\text{s}$ (SSITOUT)

Output $I_{\Delta UI} \geq 2V/20\text{mA}$
 Input $I_{\Delta UI} \geq 0.3V$

9.15 Digital and analog inputs and outputs

9.15.1 Analog Inputs (X3)

The servo amplifier is fitted with two programmable differential inputs for analog setpoints. AGND (X3/7) must always be joined to control GND as a ground reference.

Technical characteristics

- Differential-input voltage max. ± 10 V
- Ground reference AGND, terminal X3/7
- Input resistance 2.4 k Ω
- Common-mode voltage range for both inputs ± 10 V
- Update rate 62.5 μ s

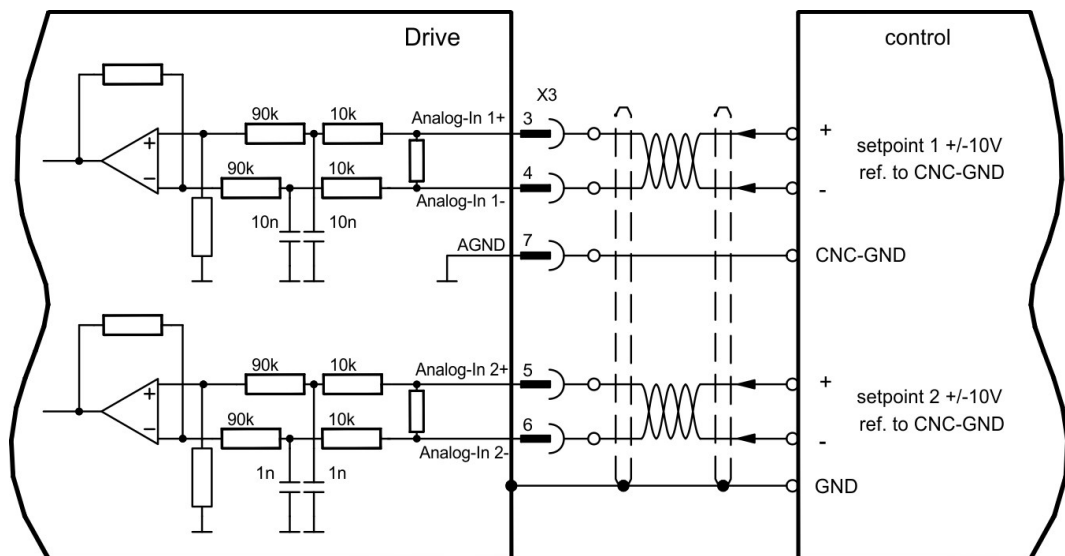

Analog-In 1 input (terminals X3/3-4)

Differential input voltage max. ± 10 V, resolution 14-bit, scalable.
Standard setting : speed setpoint

Analog-In 2 input (terminals X3/5-6)

Differential input voltage max. ± 10 V, resolution 12-bit, scalable.
Standard setting : torque setpoint

Application examples for setpoint input Analog-In 2:

- adjustable external current limit
- reduced-sensitivity input for setup or jog operation
- pre-control, override

Defining the direction of rotation

Standard setting : clockwise rotation of the motor shaft (looking at the shaft end)

- Positive voltage between terminal X3/3 (+) and terminal X3/4 (-) or
- Positive voltage between terminal X3/5 (+) and terminal X3/6 (-)

To reverse the direction of rotation, swap the connections to terminals X3/3-4 or X3/5-6 respectively, or change the ROTATION DIRECTION parameter in the "Speed controller" screen page.

9.15.2 Digital Inputs (X3/X4)

All digital inputs are electrically isolated via optocouplers.

Technical characteristics

- Ground reference is Digital-GND (DGND, terminals X4/3 and X4/4)
- The inputs at X3 are PLC-compatible (IEC 61131-2 Type 1)
High: 11...30 V / 2...11 mA , Low: -3...5 V / <1 mA
- Update rate Software: 250 μ s / Hardware: 2 μ s

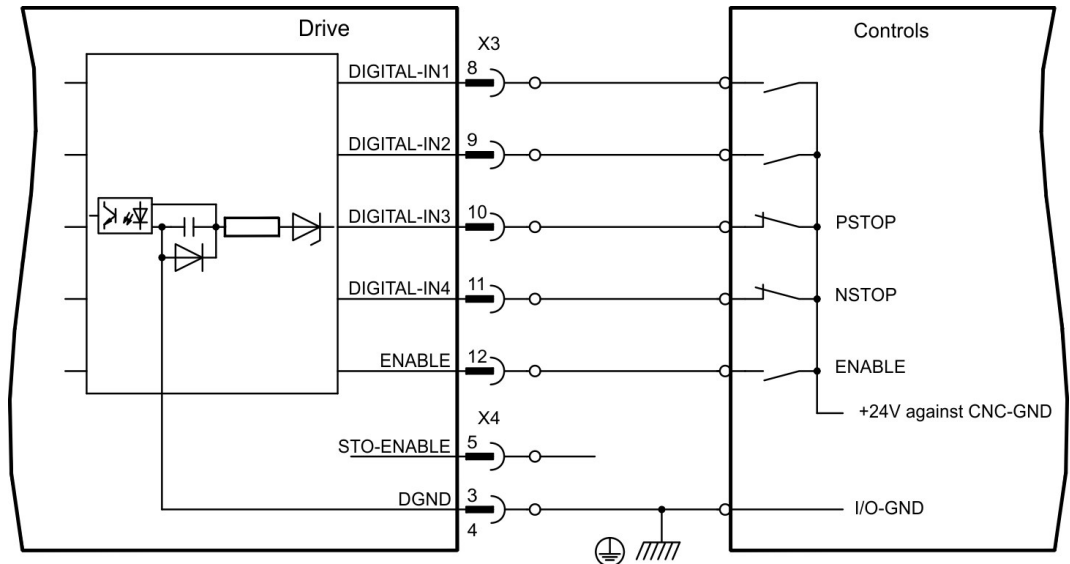

ENABLE input

The output stage of the servo amplifier is enabled by applying the ENABLE signal (terminal X3/12, 24 V input, active high). Enable is possible only if input STO-Enable has a 24 V signal (see (→ # 38)ff).

In the disabled state (low signal) the connected motor has no torque.

STO-ENABLE Input

An additional digital input (STO-Enable) releases the power output stage of the amplifier as long as a 24 V signal is applied to this input. If the STO-Enable input goes open-circuit, then power will no longer be supplied to the motor, the drive will lose all torque and coast down to a stop. A fail-safe brake function for the drive, if one is required, must be ensured through a mechanical brake since electrical braking with the aid of the drive is no longer possible.

You can thus achieve a restart lock-out for functional safety by using the STO-Enable input in conjunction with an external safety circuit. You can find further information and connection examples on page (→ # 38)ff.

NOTE

Der Eingang STO-Enable ist nicht kompatibel zu EN 61131-2.

Programmable digital inputs:

You can use the DIGITAL-IN1 to DIGITAL-IN4 digital inputs to initiate pre-programmed functions that are stored in the servo amplifier. A list of these pre-programmed functions can be found on the "Digital I/O" screen page of our setup software.

If an input was freshly assigned to a pre-programmed function, then the data set must be saved in the EEPROM of the servo amplifier and a reset has to be carried out (with the amplifier setup software for example).

9.15.3 Digital Outputs (X3)

Technical characteristics

- Ground reference is Digital-GND (DGND, terminals X4/3 and X4/4)
- All digital outputs are floating
- DIGITAL-OUT1 and 2 : Open Emitter, max. 30 V DC, 10 mA
BTB/RTO : Relay output, max. 30 V DC or 42 V AC, 0.5 A
- Update rate 250 μ s

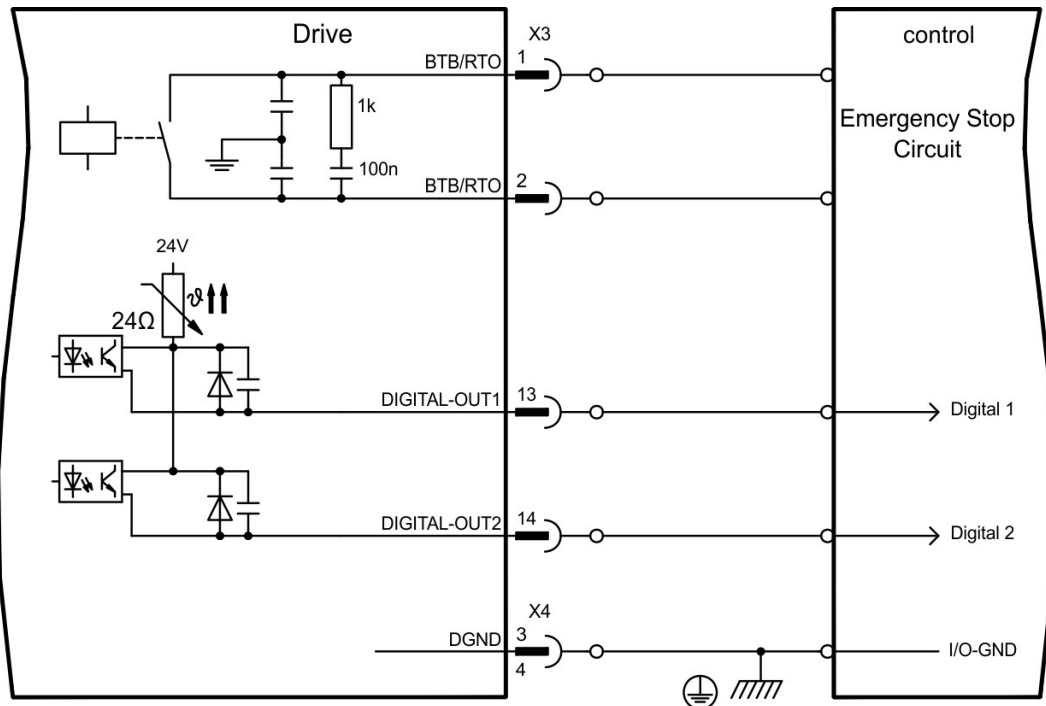

Ready-to-operate contact BTB/RTO (X3/1-2)

Operational readiness (terminals X3/1 and X3/2) is signaled by a **floating** relay contact. The contact is **closed** when the servo amplifier is ready for operation, and the signal is not influenced by the enable signal, the I^2t -limit, or the brake threshold.

NOTE

All faults cause the BTB/RTO contact to open and the output stage to be switched off (if the BTB/RTO contact is open, the output stage is inhibited -> no power output). A list of the error messages can be found on page (→ # 112).

Programmable digital outputs DIGITAL-OUT 1 and 2 (X3/13, 14):

You can use the digital outputs DIGITAL-OUT1 (terminal X3/13) and DIGITAL-OUT2 (terminal X3/14) to output messages from pre-programmed functions that are stored in the servo amplifier.

A list of these pre-programmed functions can be found on the "I/O digital" screen page of our setup software.

If an output is to be freshly assigned to a pre-programmed function, then the parameter set must be saved in the EEPROM of the servo amplifier and a reset has to be carried out (with the amplifier setup software for example).

9.16 RS232 interface, PC connection (X6)

Operating, position control, and motion-block parameters can be set up by using the setup software on an ordinary commercial PC (→ # 99).

Connect the PC interface (X6) of the servo amplifier to a serial interface on the PC, **while the power supply to the equipment is switched off.**

NOTE

Do not use a null-modem power link cable!

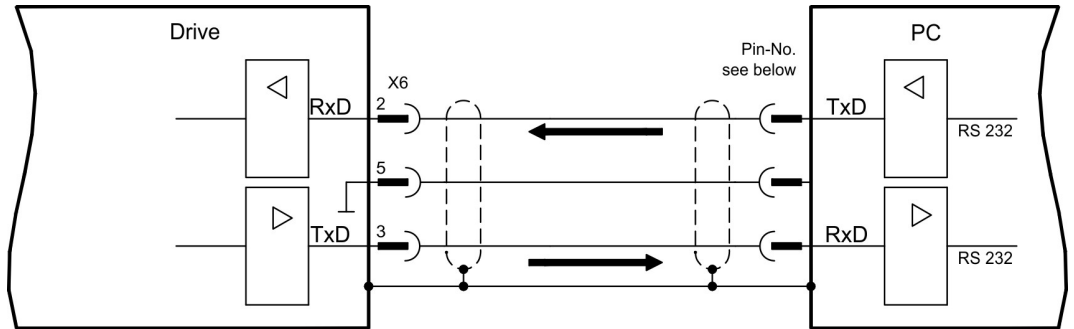

This interface has the same electrical potential as the CANopen interface.

The interface is selected and set up in the setup software. Further notes (→ # 98).

With the optional expansion module -2CAN- the two interfaces for RS232 and CAN, which otherwise use the same connector X6, are separated onto two connectors (→ # 131).

Interface cable between the PC and servo amplifiers of the S300 series:

(View : looking at the solder side of the SubD sockets on the cable)

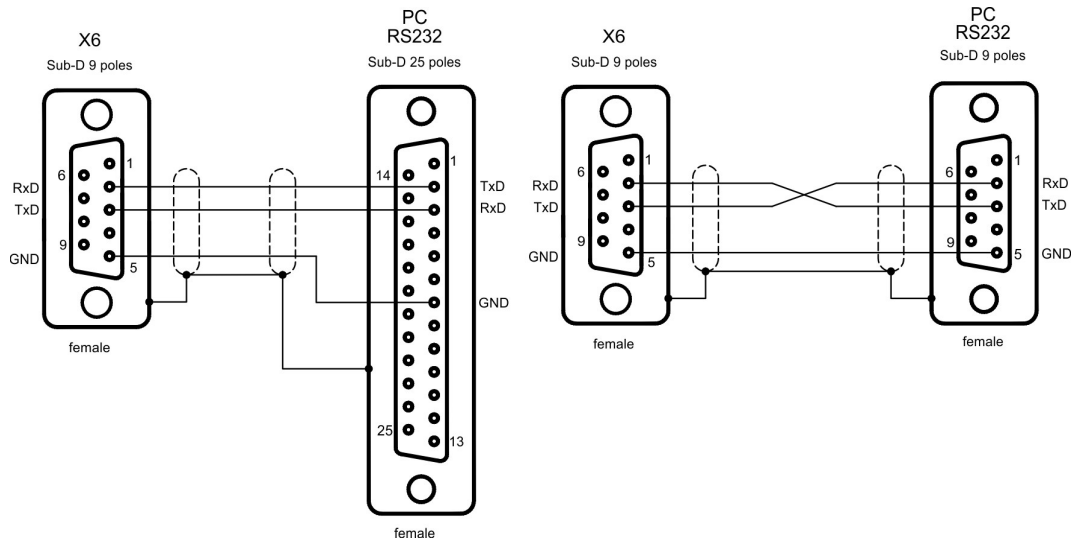

9.17 CAN-bus interface (X6)

The interface for connection to the CAN-bus (default : 500 kBaud). The integrated profile is based on the CANopen DS301 communication profile and the DS402 drive profile. The following functions are available in connection with the position controller: Jogging with variable speed, homing run (zeroing to reference), start motion task, start direct task, digital setpoint provision, data transmission functions and many others. Detailed information can be found in the CANopen manual. The interface is at the same

Detailed information can be found in the CANopen manual. The interface is at the same electrical potential as the RS232 interface. The analog setpoint inputs can still be used. With the optional expansion module -2CAN- the two interfaces for RS232 and CAN, which otherwise use the same connector X6, are separated onto two connectors (→ # 131).

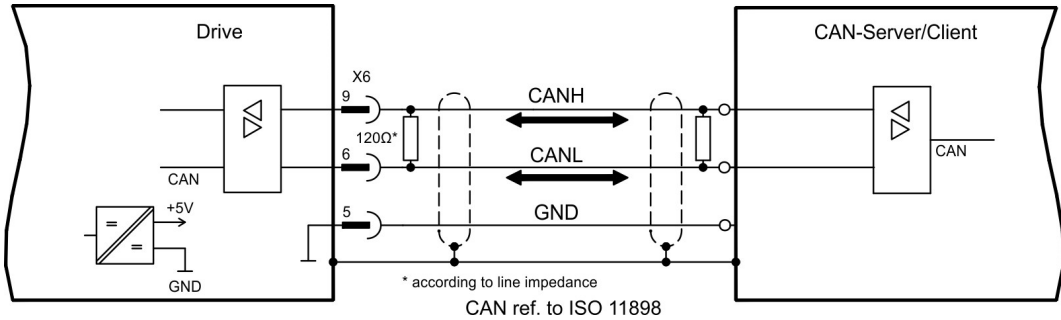

CAN-bus cable

To meet ISO 11898, a bus cable with a characteristic impedance of 120 Ω should be used. The maximum usable cable length for reliable communication decreases with increasing transmission speed. As a guide, you can use the following values which we have measured, but they are not to be taken as assured limits:

- Characteristic impedance 100-120 Ω
- Cable capacitance max. 60 nF / 1000m
- Lead loop resistance 159.8 Ω / 1000m

Cable length, depending on the transmission rate (samples)

Baudrate / kBaud	max. cable length / m
1000	10
500	70
250	115

Lower cable capacitance (max. 30 nF / km) and lower lead resistance (loop resistance, 115Ω / km) make it possible to achieve greater distances. (Characteristic impedance 150 ± 5Ω => terminating resistor 150 ± 5Ω).

For EMC reasons, the SubD connector housing must fulfill the following requirements:

- metal or metalized housing
- provision for cable shielding connection on the housing, large-area connection

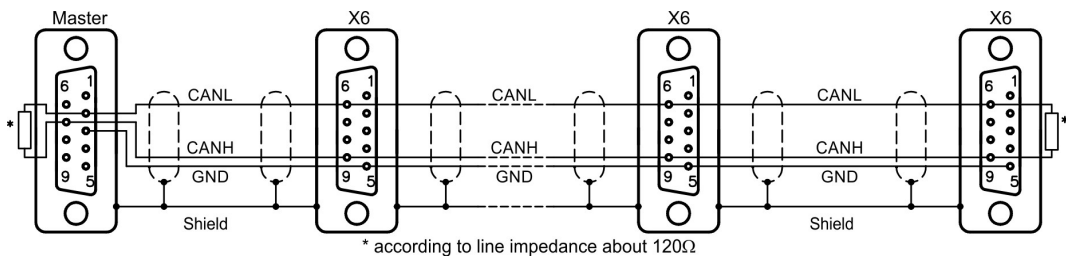

10 Setup

The procedure for setup is described as an example. Depending on the application, a different procedure may be appropriate or necessary. In multi-axis systems, set up each servo amplifier individually.

Before setting up, the manufacturer of the machine must generate a risk assessment for the machine, and take appropriate measures to ensure that unforeseen movements cannot cause injury or damage to any person or property.

10.1 Important Notes

NOTICE

Only professional personnel with extensive knowledge in the fields of electrical engineering and drive technology are allowed to test and set up the drive.



⚠ DANGER Lethal Voltage!

There is a danger of serious personal injury or death by electrical shock. Lethal danger exists at live parts of the device.

- Built-in protection measures such as insulation or shielding may not be removed.
- Work on the electrical installation may only be performed by trained and qualified personnel, in compliance with the regulations for safety at work, and only with switched off mains supply, and secured against restart.
- In normal operation, the cabinet door must be closed and the device must not be touched.



⚠ WARNING Automatic Restart!

Risk of death or serious injury for humans working in the machine. The servo amplifier might restart automatically after power on, voltage dip or interruption of the supply voltage, depending on the parameter setting. If parameter [AENA](#) is set to 1,

- then place a warning sign (Warning: Automatic Restart at Power On) to the machine.
- Ensure, that power on is not possible, while humans are in a dangerous zone of the machine.

NOTICE

If the servo amplifier has been stored for longer than 1 year, then the DC bus link capacitors will have to be re-formed. To do this, disconnect all the electrical connections.

Supply the servo amplifier for about 30 minutes from single-phase 230VAC to the terminals L1 / L2. This will re-form the capacitors.

NOTE

The adaptation of parameters and the effects on the control loop behavior are described in the [Online Help](#) of the setup software.

The setting up of any expansion card that may be fitted is described in the corresponding manual on the CD-ROM.

We can provide further know-how through training courses (on request).

10.2 Setup software

This chapter describes the installation of the setup software DRIVEGUI.EXE for the S300 digital servo amplifiers.

We offer training and familiarization courses on request.

10.2.1 Use as directed

The setup software is intended to be used for altering and saving the operating parameters for the S300 series of servo amplifiers. The attached servo amplifier can be set up with the help of this software, and during this procedure the drive can be controlled directly by the service functions.

Only professional personnel who have the relevant expertise described on page (→ # 12) are permitted to carry out online parameter setting for a drive that is running.

Sets of data that have been stored on data media are not safe against unintended alteration by other persons. After loading a set of data you must therefore always check all parameters before enabling the servo amplifier.

10.2.2 Software description

The servo amplifiers must be adapted to the requirements of your machine. Usually you will not have to carry out this parameter setting yourself on the amplifier, but on a PC, with the assistance of the setup software. The PC is connected to the servo amplifier by a null-modem cable (serial, (→ # 95)). The setup software provides the communication between the PC and S300.

You can find the setup software on the accompanying CD-ROM and in the download area of our website.

With very little effort you can alter parameters and instantly observe the effect on the drive, since there is a continuous (online) connection to the amplifier. At the same time, important actual values are read out from the amplifier and displayed on the monitor of the PC (oscilloscope functions).

Any expansion cards built into the amplifier are automatically recognized, and the additional parameters which are required for position control or motion-block definition are made available.

You can save sets of data on data media or on the memory card (archiving) and load them again. You can also print out the data sets.

We supply you with motor-specific default sets of data for the most common combinations of servo amplifier and motor. In most applications you will be able to use these default values to get your drive running without any problems.

An extensive [Online Help](#) with integrated description of all variables and functions supports you in each situation.

10.2.3 Hardware requirements, operating systems

The PC interface (X6, RS232) of the servo amplifier is connected to the serial interface of the PC by a null-modem cable (not a null-modem link cable!) (→ # 95).

NOTICE

Connect or disconnect the interface cable only when the electrical supply is switched off for both the PC and the servo amplifier.

The interface in the servo amplifier has the same potential level as the CANopen interface.

Minimum requirements for the PC:

Processor:	At least Pentium® II or comparable
Graphics adapter:	Windows compatible, color
Drives:	Hard disk with at least 10 MB free space CD-ROM drive
Interface:	one free serial interface (COM1 ... COM10) or USB with an USB->Serial converter

Operating systems WINDOWS 2000, XP, VISTA, 7 / 8 / 10

DRIVEGUI.EXE will run under WINDOWS 2000, XP, VISTA, 7, 8 and 10.

Emergency operation is feasible through an ASCII terminal emulation (without graphical user interface).

Interface settings : 38400 bps, databit 8, no parity, stopbit 1, no flow control

Operating systems Unix, Linux

The functioning of the software has not been tested for WINDOWS running within Unix or Linux.

10.2.4 Installation under WINDOWS

The CD-ROM includes an installation program for the setup software.

Installation

Autostart function activated:

Insert the CD-ROM into a free drive. A window with the start screen opens. There you find a link to the setup software DRIVEGUI.EXE. Click it and follow the instructions.

Autostart function deactivated:

Insert the CD-ROM into a free drive. Click on **START** (task bar), then on **Run**. Enter the program call: **x:\index.htm** (x = correct CD drive letter).

Click **OK** and proceed as described above.

Connection to the serial interface of the PC:

Connect the interface cable to a serial interface on your PC (COM1 to COM10) and to the serial interface of the servo amplifier S300 (→ # 95).

10.3 Quickstart, initial drive test

10.3.1 Preparation

Unpacking, Mounting and Wiring the Servo Amplifier

1. Unpack servo amplifier and accessories.
2. Observe safety instructions in the manuals.
3. Mount the servo amplifier as described in chapter "Mechanical Installation" (→ # 45).
4. Wire the servo amplifier as described in chapter "Electrical Installation" (→ # 48) or apply the minimum wiring for drive testing as described on the next page.
5. Install the software (→ # 98).
6. You need this information concerning the drive components:
 - Rated mains supply voltage
 - motor type (motor data, if the motor type is not listed in the motor database, see [Online-Help](#))
 - feedback unit built into the motor (type, poles, lines, protocol etc.)
 - moment of inertia of the load

Documents

You need access to these documents (located on the product CD-ROM, you can download the latest editions from our website):

- Instruction manual (this manual)
- CANopen Fieldbus Interface Manual
- Accessories manual

Depending on the installed expansion card you need one of these documents:

- PROFIBUS DP Fieldbus Interface Manual
- PROFINET Fieldbus Interface Manual
- DeviceNet Fieldbus Interface Manual
- sercos® Fieldbus Interface Manual
- EtherCAT Fieldbus Interface Manual

You need Acrobat Reader to read the PDFs, an installation link is on every screen of the product CD-ROM.



Minimum Wiring for Drive Test

NOTE

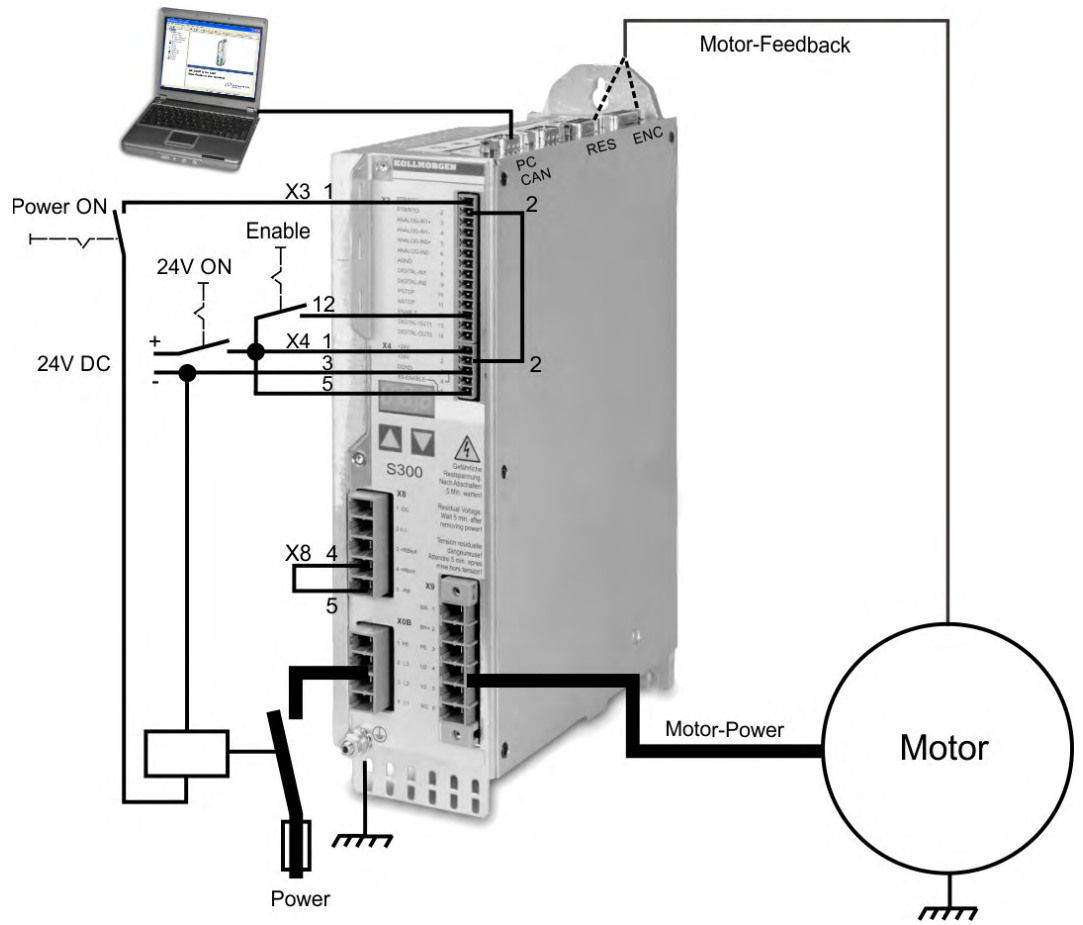
This wiring does not fulfill any requirements to safety or functionality of your application, it just shows the required wiring for drive testing without load.



10.3.2 Connect

- Connect the interface cable to a serial interface on your PC and to the serial interface X6 of the servo amplifier. USB to serial converter can be used optionally.
- Switch on the 24 V power supply for the servo amplifier.
- Wait about 30 seconds, until the front display of the servo amplifier displays the current class (e.g.  for 3 A) anzeigt. If the power supply voltage is switched on, too, leading P is displayed (e.g.  for Power, 3 A).

If a fault code () or a warning () or a status message (./_ / E/S) appears in the display, you will find the description on page (→ # 112) or (→ # 113).

If a fault message appears, fix the problem.



Double-Click the DRIVEGUI.EXE icon on your Windows desktop to start the software.

You can work offline or online with DRIVEGUI.EXE. Work ONLINE now.

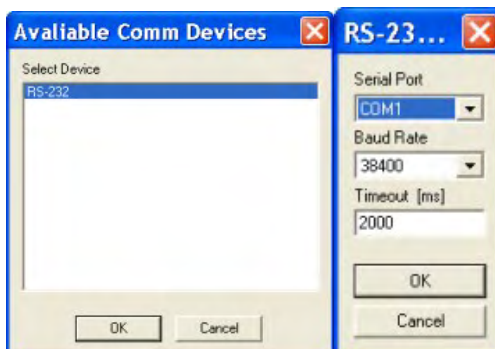

If the communication is started for the first time, you have to setup the communication parameters. Choose the communication system and the interface, where the servo amplifier is connected to. Click OK.

The software tries to communicate with these parameters. If it's not successful, you receive this error message:



Frequent causes:

- wrong interface chosen
- wrong connector chosen at the servo amplifier
- interface is used by another software
- 24 V auxiliary voltage for the servo amplifier not working
- interface cable broken or wrong wiring

Quit the error message. The software starts in the offline mode now, that requires the manual selection of the amplifier's type. Quit this selection by closing the window. Fix the communication problem. Restart the software in Online mode.

If communication works, you see the start screen. Select "Setup Wizard" in the navigation frame.

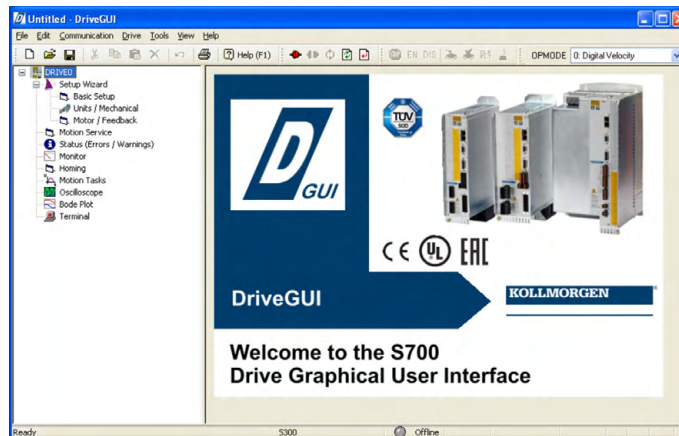

NOTICE

Make sure, that the amplifier is disabled (Input Enable connector X3/12 = 0 V or open)!



10.3.3 Important Screen Elements

Help Function

The [online help](#) gives detailed information to all parameters the servo amplifier can work with.

Key F1	Starts online help for the actual screen page.
Menu bar Help	Starts online help with the first page.
	Context Help. Click the help symbol first. Then click the function for which you need help.

Tool Bar

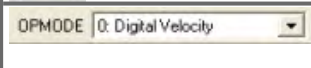
	Save to EEPROM, required if you changed parameters.
	Reset, required if you changed configuration parameters.
	Operation Mode, use "0: Digital Velocity" mode for drive testing.

Status Bar

Ready	 Online	Disabled	Warning	not homed
-------	--	----------	---------	-----------

The status bar shows a green Online symbol, indicating that the communication works.

10.3.4 Setup Wizard

The Setup Wizard leads you through the necessary steps for configuring your servo amplifier. Depending on the selected application, only the active screen pages are necessary.

Welcome to the Drive Setup Wizard

This Setup Wizard will help you configure your drive. Start by choosing the type of set up from the list below: "Quick Motor/Drive Setup", "Analog Application Setup", "Gearing Application Setup", "Motion Task Application Setup" or "Complete Setup".

Click "Next" and "Previous" to move between screens, or move directly to any screen by clicking in the tree on the left. Click the "Refresh" toolbar button to bring back the original data for the screen currently showing.

When a new wizard page is opened, the current parameter values related to that page are reloaded from the drive.

Select Type of Setup Wizard

Standard Servo Setups

- Quick Motor/Drive Setup
- Analog Application Setup
- Gearing Application Setup
- Motion Task Application Setup
- Complete Setup

Sensorless Setups

- Induction Motor Setup (U/f Control)

Enter Setup Wizard

For a quick setup / drive test, select the setup type "Quick Motor/Drive Setup".

Start the Wizard.

10.3.4.1 Basic Setup

Basic Setup

Power Supply

Regen Resistor

- Internal Value: 0 Ohms
- External

max. Regen Power: 50 W

Mains Voltage: 230 V

Response to Loss of Input Phase: Three-Phase (Current Limit), Warning n05

Amplifier

Hardware: Drive 1.5A

Firmware: V3.00 DRIVE Rev create.d Feb 27 08:00:42 2008

Serial Number: 0

Run Time: xxxxxx h

Name: DRIVE0

Set Software-Enable on Bootup

Next >

Basic parameters are set here.

Mains Voltage: Select actual mains voltage.

Response to Loss of Input Phase: Select Single-Phase or Three-Phase . With three-phase operation you can select either warning "n05" or error "F19" in case of phase loss. The reaction "F19" disables the output stage, "n05" is just a message.

Name: You can enter a name for the servo amplifier (up to 8 characters). This simplifies the drive identification in the system.

Set Software Enable on Bootup: Do **not** select this option for the quick test.

Click NEXT.

10.3.4.2 Units/Mechanical

The user units for all input fields in the setup software can be preselected here.

Position, Velocity, Acceleration

Select usable units for your application referring to the moved load.

Mechanical Conversion

The relationship between motor shaft revolution (pole pair pitch with linear motors) and motion distance of the load is specified here. Gear ratio can be calculated here as well. Detailed information can be found in the [Online-Help](#).

Use the tool based on sample applications for calculating the resolution value:

Calculate PGEARI/PGEARO for..." button

If your application does not correspond to any of the listed examples, enter the required parameters directly in the fields on the "Units" screen.

First, select the application that corresponds to your own. Next, set the position unit. Select the position unit that provides you with the required accuracy for your application.

Set the mechanical data for you application now. If a gearhead is flange-mounted on the motor, you must also enter the gearhead data (either the number of teeth or the ratio of the revolutions).

Then click the "Calculate conversion factors and return" button.

Click NEXT.

10.3.4.3 Motor (rotary) and Feedback

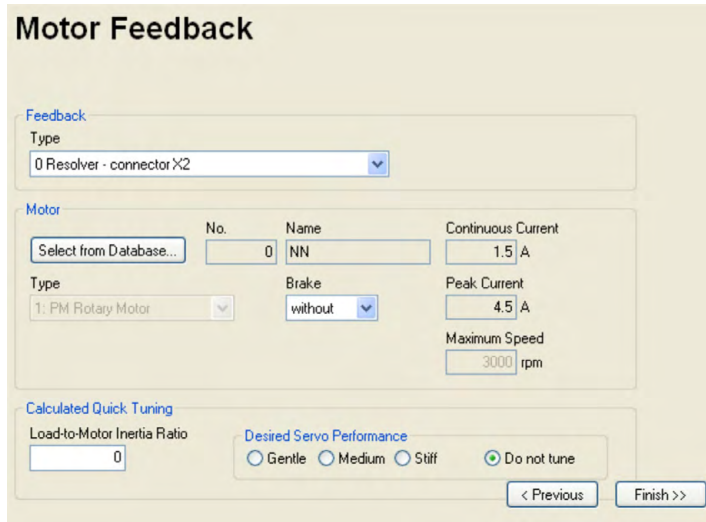

Simplified setting of the motor related parameters.

Feedback: Select the feedback system used in the motor.

NOTE

Resolver is fixed to 2 pole in the Quick Motor/Drive Setup. Change "pole n°" on feedback screen in Complete Setup later, if required.

Motor type: Click the button "Select from Database...". Open the database file (mdb_*.csv) and select the used motor out of the list. Special motors must be defined in the "Complete Setup".

Brake: If the amplifier shall control a brake, change the Brake parameter to "With"

Calculated quick tuning: If you know the Load-to-motor inertia ratio (0 is for no load), enter the number here and select the desired servo performance. If you don't know the inertia ratio, select "Do not tune". **Click FINISH.**

10.3.4.4 Motor (linear) / Feedback (Encoder)

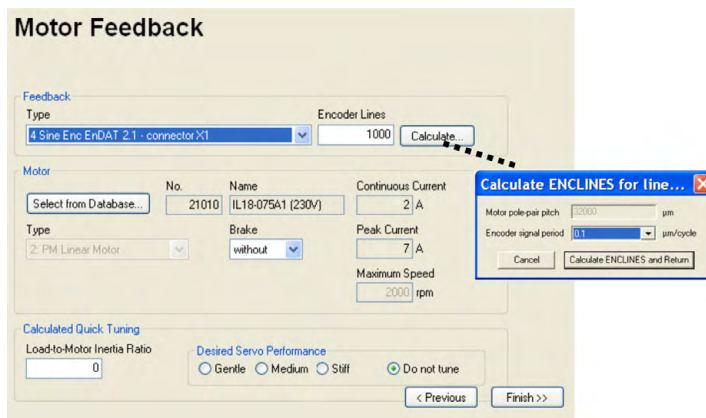

Simplified setting of the motor related parameters.

Feedback: Select the feedback system used.

Motor type: Click the button "Select from Database..". Open the database file (mdb_*.csv) and select the used motor. Special motors must be defined in the "Complete Setup".

Encoder Lines (appears with Feedback Type Sine Encoder): Click "Calculate" and fill in the Encoder signal period.

Brake: If the amplifier shall control a brake, change the Brake parameter to "With"

Calculated quick tuning: If you know the Load-to-motor inertia ratio, enter the number here and select the desired servo performance. Otherwise select "Do not tune".

Click FINISH.

10.3.4.5 Save Parameters and Restart

You are going to finish the Setup Wizard and you have changed several basic parameters. Depending on the parameters you changed, two possible reactions will occur now:

Configuration parameters changed

A warning appears, that you have to restart the amplifier, this is called "coldstart".

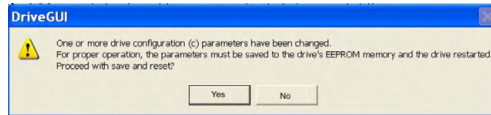

Click "YES".

The parameters are saved to the amplifier's EEPROM automatically and a reset command restarts the amplifier (takes some seconds).



Other parameters changed

No warning appears. Save the parameters to the EEPROM of the servo amplifier manually by clicking the symbol  in the tool bar. A coldstart of the amplifier is not necessary. Select the screen "Motion Service" in the navigation frame.

10.3.5 Motion Service (Jog Mode)

NOTICE

Be aware that the actual position of the load permits the subsequent moving operations. The axis could move to the hardware limit-switch or the mechanical stop. Make sure that a jerk or a fast acceleration of the load cannot cause any damage. Observe the "safe reduced speed" requirements for your application!

- Switch on the power supply for the drive.
- **STO-Enable:** Apply +24 V to STO-Enable [X4/5]
- **Hardware-Enable:** Apply +24 V to input Enable [X3A/12]. If STO-Enable is missed or the sequence was wrong, the front display shows .
- **Software-Enable:** Click the symbol  in the tool bar.

Now the front display shows an E and the current class (e.g.  for Enable, 3A).

Click the symbol  to switch off the output stage (disable).

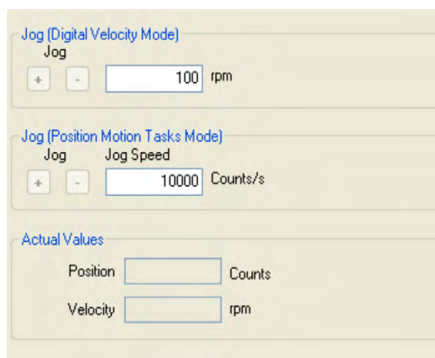

Jog (Digital Velocity Mode):

You can move the drive with constant speed. Enter the desired speed.

Observe the "safe reduced speed" requirements for your application!

The drive moves with the preset speed when the + or - button is pressed. It stops when the button is released.

Actual errors and warnings are listed on the screen "Status". A description of errors and warnings can be found in the [Online-Help](#) or on page (→ # 112) ff.

Now you have setup and tested the basic functions of the drive successfully.

10.3.6 More Setup Screens

NOTICE

Observe the safety instructions in the manuals and in the [online help](#) before you change parameters in the additional setup screens.

For all setup functions detailed information can be found in the [online help](#) system and the integrated command reference.

Select "Complete Setup" in the Setup-Wizard. Now you have access to:

- **CAN- and Feldus settings:** Setup address and baudrate
- **Feedback:** Adjust the used feedback unit
- **Motor:** Adjust the used motor
- **Control Loops:** Current-, Velocity- and Position-Loops can be optimized
- **Position Data:** Adjust the position control for the requirements of your application.
- **Position Registers:** Up to 16 position values in the motion way can be monitored.
- **Electronic Gearing:** If the servo amplifier will follow a setpoint as a slave with a gear ratio, you can select the gearing source here and define the gear ratio.
- **Encoder Emulation:** Select the encoder emulation (position output)
- **Analog I/O:** Setup the analog inputs
- **Digital I/O:** Setup the digital inputs and digital outputs
- **Status (Errors/Warnings):** Displays amplifiers data with history, actual faults and warnings
- **Monitor:** Displays the drive data (actual values)
- **Homing:** Definition and start of homing
- **Motion task:** Definition and start of motion task
- **Oscilloscope:** 4 channel oscilloscope with multiple functionality
- **Bode Plot:** Tool for optimizing the drive
- **Terminal:** Setup the servo amplifier with ASCII commands
- **Expansion Card:** Depending on the built-in expansion card a menu appears
- **Autotuning:** Fast tuning of the velocity controller

10.4 Multi axis system

With a special cable you can connect up to 255 servo amplifiers to your PC: cable type - SR6Y- (for four amplifiers) or -SR6Y6- (for six amplifiers) see Accessories Manual.

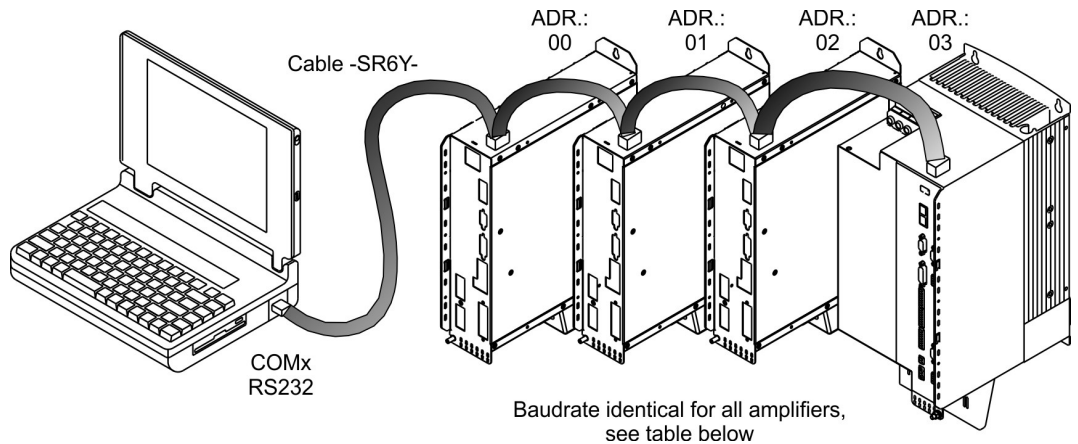

With the PC connected to only one amplifiers you can select every amplifier in the system via the set station address with the setup software.

Node address for CAN-bus

You can use the keypad on the front panel to preset the station addresses for the individual amplifiers and the baud rate for communication (→ # 111). Usually the setup software is used to set all parameters.

Baud rate for CAN-bus

NOTE

After changing the station address and baud rate you must turn the 24V auxiliary supply for the servo amplifier off and on again.

Coding of the Baud rate in the LED display:

Coding	Baud rate in kBit/s	Coding	Baud rate in kBit/s
1	10	25	250
2	20	33	333
5	50	50	500
10	100	66	666
12	125	80	800
		100	1000

10.5 Keypad operation and LED display

This section illustrates the two possible operating menus and the use of the keys on the front panel. Normally, the S300 only presents the standard menu for your use. If you want to operate the amplifier via the detailed menu, you must keep the right key pressed while switching on the 24V supply.

10.5.1 Operation

The two keys can be used to perform the following functions:

Key symbol	Functions
	press once : go up one menu item, increase number by one press twice in rapid succession : increase number by ten
	press once : go down one menu item, decrease number by one press twice in rapid succession : decrease number by ten
	press and hold right key, then press left key as well : enter a number, return function name

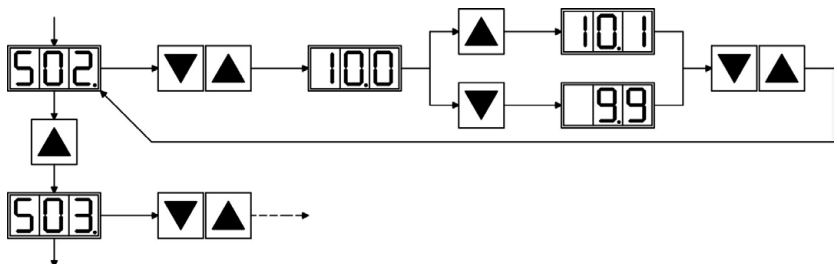

10.5.2 Status display

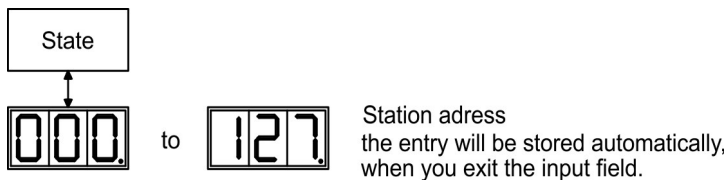

10.5.3 Standard menu structure

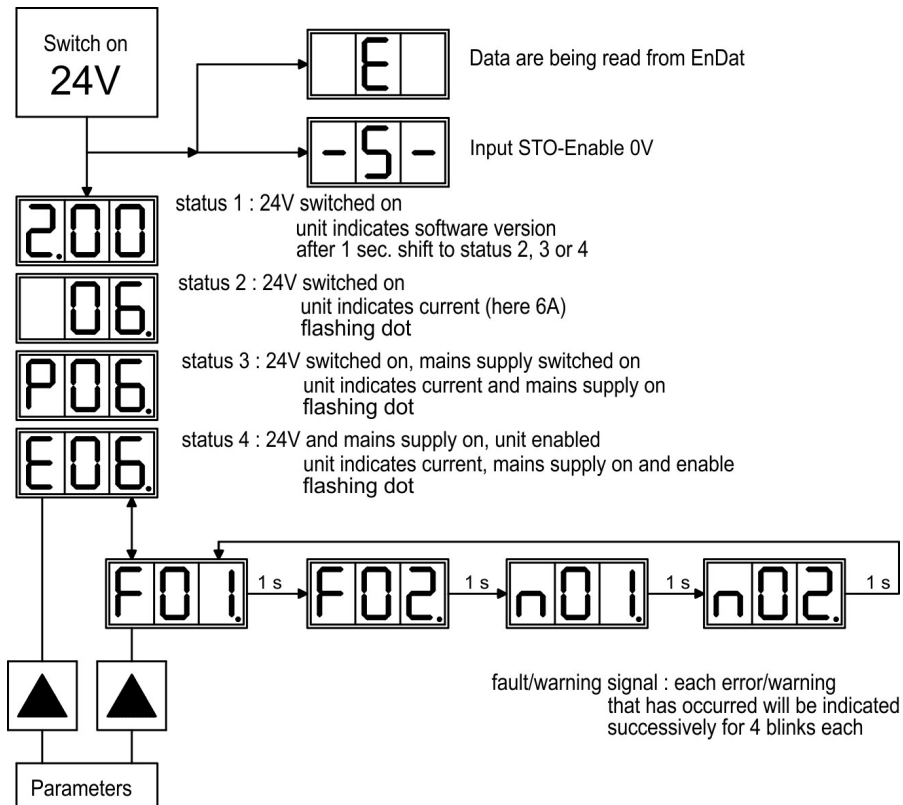

10.5.4 Advanced menu structure

NOTE

To operate the amplifier via the detailed menu, you must keep the right key pressed while switching on the 24 V supply.

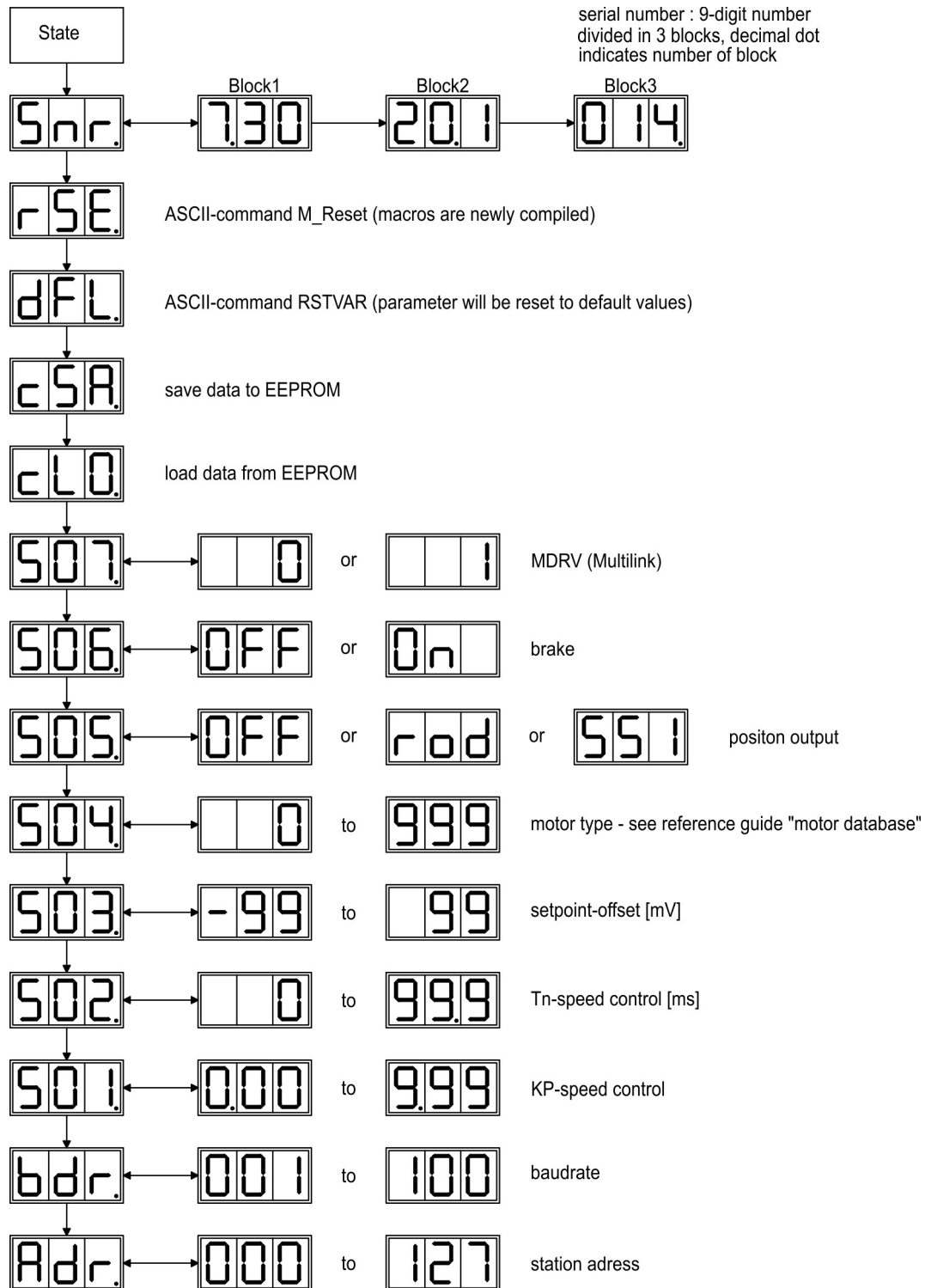

10.6 Error messages

Any errors that occur are shown in coded form by an error number in the [LED-Display](#) on the front panel. [ERRCODE2](#) shows additional information coded with "ixx" for faults with an asterisk "*" in the table below. The servo amplifier reaction depends on the fault and on the setting of parameter [ACTFAULT](#). Faults can be reset by hardware reset of the servo amplifier or depending on the fault (see [ERRCODE](#)) by ASCII command [CLRFAULT](#)

Number	Designation	Explanation (ASCII Reference ERRCODE)
E or P	Status messages	Status messages, no error (→ # 110)
. . .	Status message	Updating the startup configuration
-	Status message	Programming mode
- S -	STO-Enable	STO-Enable input is 0V (with disabled drive only)
CCC	Memory Card	Access problems memory card
F01	Heat Sink Temperature	Heat sink temperature too high limit is set by manufacturer to 80°
F02	Overvoltage	Overvoltage in DC bus link limit depends on the electrical supply voltage
F03	Following Error	Message from the position controller
F04*	Feedback	Cable break, short-circuit, short to ground
F05	Undervoltage	Undervoltage in DC bus link, limit is set by manufacturer to 100V
F06	Motor Temperature	Motor temperature too high or temp. sensor defect
F07*	Internal Voltages	Internal amplifier supply voltages are out of tolerance
F08	Overspeed	Motor over-revs, speed is too high
F09	EEPROM	Checksum error
F10	Signal Failure X5	Signal failure X5 (cable break or similar)
F11	Motor Brake	Motor cable break, short-circuit, short to ground
F12	Motor Phase	Motor phase missing (cable break or similar)
F13	Ambient Temperature	Ambient temperature too high
F14*	Output Stage	Fault in the power output stage or wrong motor cable or bad cable shielding
F15	I ² t max.	I ² t maximum value exceeded
F16	Mains BTB/RTO	2 or 3 phases missing in the mains supply feed
F17	A/D Converter	Error in the analog-digital conversion
F18*	Brake Circuit	Brake circuit faulty or incorrect setting
F19	DC Bus Link	DC bus link breakdown
F20*	Slot Error	Slot error, depends on the type of expansion card, see ASCII object reference, ERRCODE*
F21	Handling Error	Handling error on the expansion card
F22	Reserved	Reserved
F23	CAN Bus Off	Severe CAN bus communication error
F24	Warning	Warning is displayed as fault
F25*	Commutation Error	Commutation error
F26	Limit Switch	Hardware limit switch error on homing move
F27	STO	Operational error with STO, input for STO-Enable and ENABLE have been set at the same time
F28	Fieldbus Error	Fieldbus error, see ASCII object reference, ERRCODE*
F29*	Fieldbus Error	Communication disturbed, see ASCII object reference, ERRCODE*
F30	Emergency Timeout	Timeout emergency stop
F31	Reserved	Reserved
F32*	System Error	System software not responding correctly

10.7 Warning messages

Faults which occur, but which do not cause a switch-off of the amplifier output stage (BTB/RTO contact remains closed), are indicated in the [LED-Display](#) on the front panel by a coded warning number.

Some warning messages result in a controlled shut-down of the drive (braking by emergency stop ramp). The servo amplifier reaction depends on the warning (see [STATCODE](#)).

Number	Designation	Explanation (ASCII Referenz STATCODE)
E/P	Status Messages	Status messages, no error (→ # 110)
. . .	Status Message	Updating the startup configuration
-	Status Message	Programming mode
- S -	STO-Enable	STO-Enable input is 0V (with disabled drive only)
n01	I ² t	I ² t threshold exceeded
n02	Brake power	Reached preset electrical brake power limit
n03	S_fault	Exceeded preset following error limit
n04	Response monitoring	Response monitoring (fieldbus) has been activated
n05	Supply phase	Mains supply phase missing
n06	SW limit switch 1	Underrun software limit switch 1
n07	SW limit switch 2	Overrun software limit switch 2
n08	Motion task error	A faulty motion task was started
n09	No reference point	No reference point (Home) set at start of motion task
n10	PSTOP	PSTOP limit-switch activated
n11	NSTOP	NSTOP limit-switch activated
n12	Motor default values loaded	Only for ENDAT/ HIPERFACE: discrepancy between motor number saved in the encoder and the amplifier, motor default values loaded
n13	Expansion card	24V supply of the I/O expansion board is missing
n14	SinCos feedback	SinCos commutation (wake & shake) not completed, will be canceled when amplifier is enabled and wake & shake carried out
n15	Table faults	Speed-Current table INXMODE 35 fault
n16	Summarized warning	Summarized warning for n17 to n31
n17	Fieldbus Synchronization	CAN sync is not logged in
n18	Multiturn overrun	Max. number of motor turns exceeded
n19	Motion task ramps are limited	Range overflow on motion task data
n20	Invalid motion task	Invalid motion task
n21	PLC program error	For details see PLC code
n22	Max. motor temperatur reached	The user can shut down the process before the temperature error will interrupt the process immediately
n23	Sin Cos feedback	Warning level reached
n24	Digital I/O	Configuration is not logical
n25...n31	reserved	reserved
n32	Firmware beta version	Firmware is an unreleased beta version

NOTE

More information to the messages can be found in the ASCII Object Reference ([online help](#)), see parameter [STATCODE](#). Hints for removal can be found in section "[Trouble-Shooting](#)" of the online help.

10.8 Trouble shooting

Depending on the conditions in your installation, there may be a wide variety of reasons for the fault. In multi-axis systems there may be further hidden causes of a fault.

NOTICE

Eliminate errors and faults in compliance with work safety rules. Troubleshooting only by qualified and trained staff.

NOTE

Detailed hints for removal of faults can be found in the [online help](#) chapter "Trouble-Shooting". Our customer service can give you further assistance with problems.

Fault	Possible causes	Measures to remove the cause of the fault
HMI message: communication fault	<ul style="list-style-type: none"> wrong cable used cable plugged into wrong position in servo amplifier or PC wrong PC interface selected 	<ul style="list-style-type: none"> use null-modem cable plug cable into the correct sockets on the servo amplifier and PC select correct interface
Motor does not rotate	<ul style="list-style-type: none"> servo amplifier not enabled break in setpoint cable motor phases swapped brake not released drive is mechanically blocked no. of motor poles set incorrectly feedback set up incorrectly 	<ul style="list-style-type: none"> apply enable signal check setpoint cable correct motor phase sequence check brake control check mechanism set no. of motor poles set up feedback correctly
Motor oscillates	<ul style="list-style-type: none"> gain too high (speed controller) shielding in feedback cable is broken AGND not wired up 	<ul style="list-style-type: none"> reduce Kp (speed controller) replace feedback cable join AGND to CNC-GND
Drive reports following error	<ul style="list-style-type: none"> I_{rms} or I_{peak} is set to low setpoint ramp is too long 	<ul style="list-style-type: none"> increase I_{rms} or I_{peak} (keep within motor limits!) shorten setpoint ramp +/-
Motor over-heating	<ul style="list-style-type: none"> I_{rms}/I_{peak} set too high 	<ul style="list-style-type: none"> reduce I_{rms}/I_{peak}
Drive too soft	<ul style="list-style-type: none"> Kp (speed controller) too low Tn (speed controller) too high ARLPF / ARHPF too high ARLP2 too high 	<ul style="list-style-type: none"> increase Kp (speed controller) use motor default value for Tn (speed controller) reduce ARLPF / ARHPF reduce ARLP2
Drive runs roughly	<ul style="list-style-type: none"> Kp (speed controller) too high Tn (speed controller) too low ARLPF / ARHPF too low ARLP2 too low 	<ul style="list-style-type: none"> reduce Kp (speed controller) use motor default value for Tn (speed controller) increase ARLPF / ARHPF increase ARLP2
Axis drifts at setpoint = 0V	<ul style="list-style-type: none"> offset not correctly adjusted for analog setpoint provision AGND not joined to the CNC-GND of the controls 	<ul style="list-style-type: none"> adjust setpoint-offset (analog I/O) join AGND and CNC-GND

11 Expansions

Information about availability and order numbers see (→ # 137).

Expansions cards can only be built into amplifiers without option -FN or -EC!

11.1 Guide to installation of expansion cards

NOTICE

Before you start working, safely disconnect the device from any voltage, that means neither the electrical power supply nor the 24 V auxiliary voltage of the servo amplifier nor the supply voltages of any other connected equipment is switched on.

Use a suitable screwdriver to lever off the cover of the option slot.

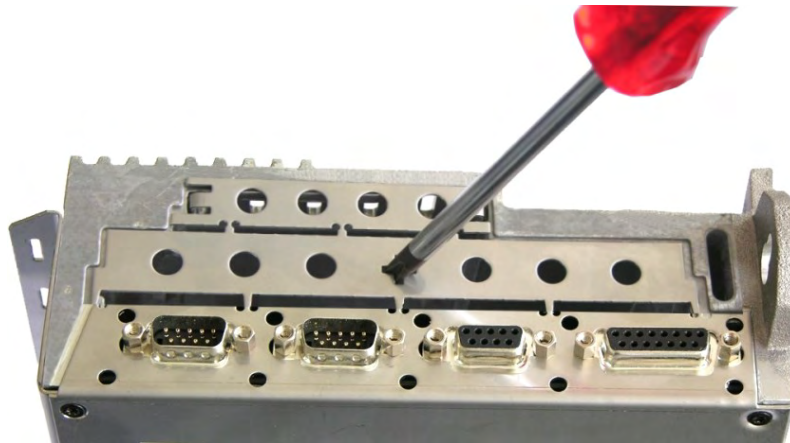

Take care that no small items (such as screws) fall into the open option slot.

Lever off the small metall sheet and push it back to the small slot. Dispose the big metall sheet.

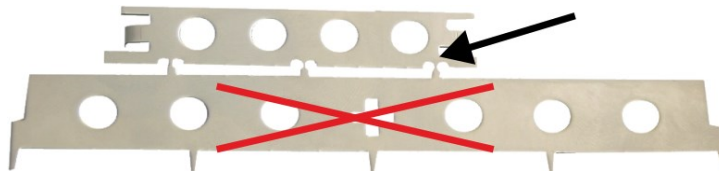

Push the expansion card carefully into the provided guide rails of the main slot, without twisting it.

Press the expansion card firmly into the slot.

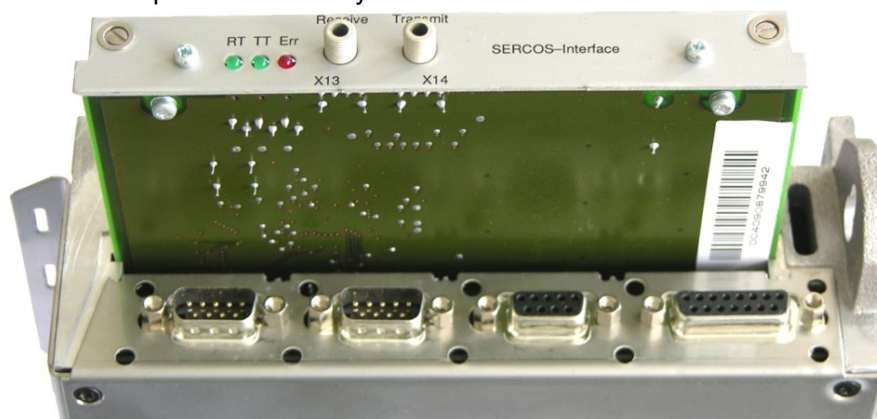

Screw the screws on the front cover into the threads in the fixing lugs. This ensures that the connectors make good contact.

11.2 Expansion card -I/O-14/08-

This section describes the additional features that the expansion card -I/O-14/08- provides for the S300. If you ordered the expansion card together with the servo amplifier, then it will be delivered already inserted into the expansion slot of the servo amplifier and screwed in place.

The -I/O-14/08- provides you with 14 additional digital inputs and 8 digital outputs. The functions of the inputs and outputs are adjustable with the setup software.

NOTE

The 24V DC voltage must be supplied by an electrically isolated power supply (e.g. with isolating transformer).

The I/Os are used to initiate the motion tasks that are stored in the servo amplifier and to evaluate signals from the integrated position control in the higher-level control system. The functions of the inputs and signal outputs correspond to the functions that can be assigned to the digital I/Os on connector X3. All inputs and outputs are electrically isolated from the servo amplifier by optocouplers.



11.2.1 Technical data

Control inputs	24V / 7mA , PLC compatible, IEC 61131
Signal output	24V / max. 500mA , PLC compatible, IEC 61131
Supply inputs, to IEC 61131	24V (18...36V) / 100mA plus total current of the outputs (depends on the input wiring of the controls)
Fusing (external)	4 AT
Connectors	MiniCombicon, 12-pin, coded on PIN1 and 12
Cables	Data – up to 50m long : 22 x 0.5 mm ² , unshielded, Supply – 2 x 1mm ² , check voltage drop
Waiting time between 2 motion tasks	Depends on the response time of the control system
Addressing time (minimum)	4ms
Starting delay (maximum)	2ms
Response time of digital outputs	max. 10ms

11.2.2 LEDs

Two LEDs are mounted next to the terminals on the expansion card. The green LED signals that the 24V auxiliary supply is available for the expansion card. The red LED signals faults in the outputs from the expansion card (overload of switching components, short-circuit).

11.2.3 Entering a motion block number (example)

Motion block number	A7	A6	A5	A4	A3	A2	A1	A0
binary 1010 1110	1	0	1	0	1	1	1	0
decimal 174	128	-	32	-	8	4	2	-

11.2.4 Connector assignments

The functions are adjustable with the setup software.

Pin	Dir	Default	Description
Connector X11A			
1	In	A0	Motion block number 2^0 , LSB
2	In	A1	Motion block number 2^1
3	In	A2	Motion block number 2^2
4	In	A3	Motion block number 2^3
5	In	A4	Motion block number 2^4
6	In	A5	Motion block number 2^5
7	In	A6	Motion block number 2^6
8	In	A7	Motion block number 2^7 , MSB
9	In	Reference	Polls the home switch. If a digital input on the base unit is used as a home input, then the input on the expansion card will not be evaluated.
10	In	F_error_clear	Clears the warning of a following error (n03) or the response monitoring (n04)
11	In	F_error_clear	The following task, that is defined in the motion task by "Start with I/O" is started. The target position of the present motion task must be reached before the following task can be started. The next motion block can also be started by an appropriately configured digital input on the base unit.
12	In	Start_Jog v= x	Starts the "Jog Mode" with a defined speed. "x" is the speed saved in the servo amplifier for the function "Jog Mode". A rising edge starts the motion, a falling edge cancels the motion.
Connector X11B			
1	In	MT_Restart	Continues the motion task that was previously interrupted.
2	Out	Start_MT I/O	Starts the motion task that is addressed by A0-A7 (connector X11A/1 to X11A8). If no motion task is addressed, then a homing task is started.
3	Out	InPos	When the target position for a motion task has been reached (the InPosition window), this is signaled by the output of a HIGH signal. A cable break will not be detected.
4	Out	Next-InPos	The start of each motion task in an automatically executed sequence of motion tasks is signaled by an inversion of the output signal. The output produces a LOW signal at the start of the first motion task of the sequence. The form of the message can be varied by using ASCII commands.
		PosReg 0	Can be adjusted by ASCII commands only.
5	Out	$\overline{F_error}$	A LOW signal indicates that the position has gone outside the acceptable following error window.
6	Out	PosReg1	default: SW limit 1, indicated by a HIGH signal
7	Out	PosReg2	default: SW limit 2, indicated by a HIGH signal
8	Out	PosReg3	Can only be adjusted by ASCII commands
9	Out	PosReg4	Can only be adjusted by ASCII commands
10	Out	PosReg5	Can only be adjusted by ASCII commands
11	-	24V DC	Supply voltage for output signals.
12	-	I/O-GND	Digital GND for the control system.

11.2.5 Connection diagram (default)

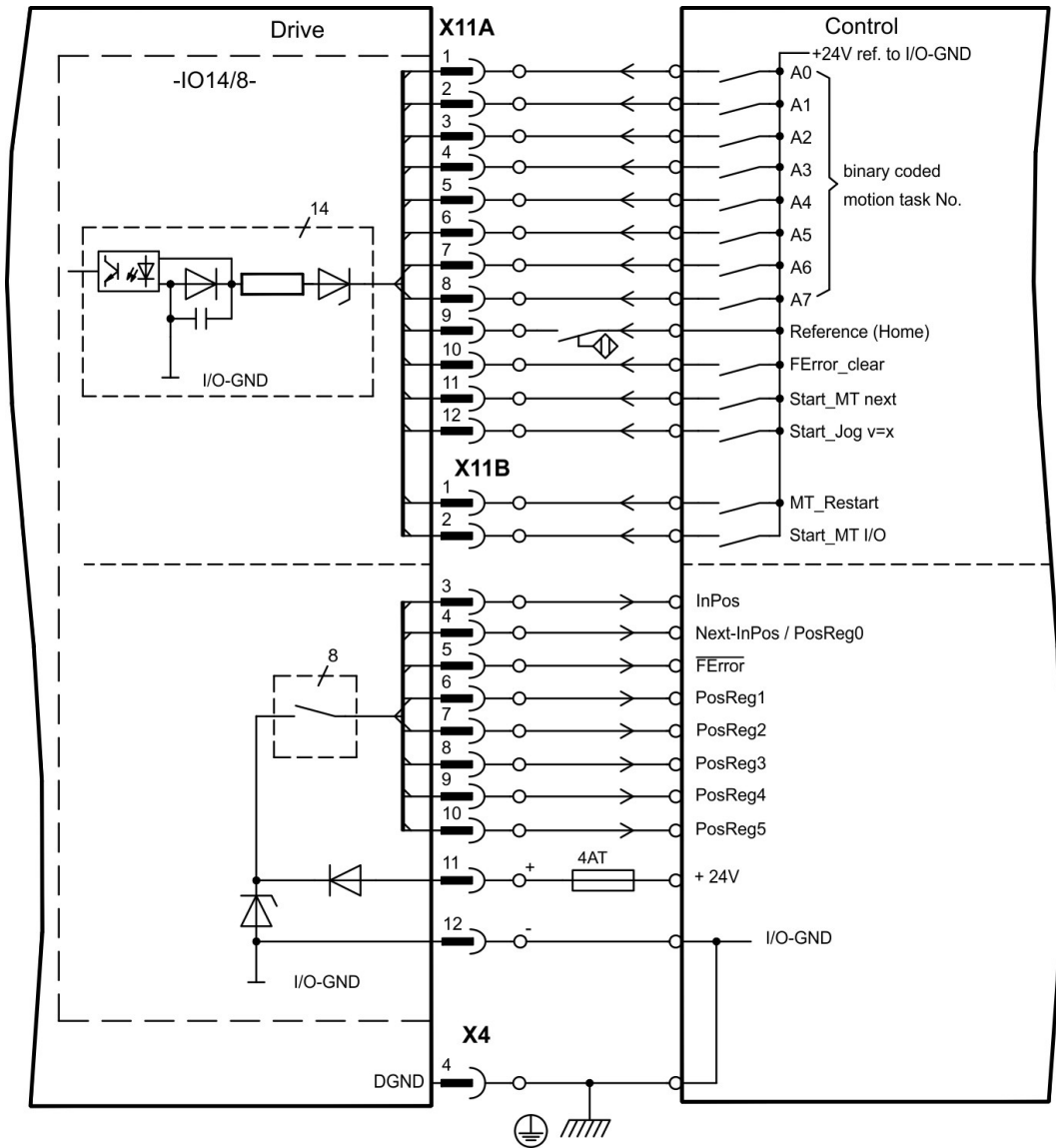

11.3 Expansion card -PROFIBUS-

This section describes the PROFIBUS expansion card for the S300. Information on the range of functions and the software protocol can be found in our manual "Communication Profile PROFIBUS DP".

The PROFIBUS expansion card has two 9-pin SubD sockets wired in parallel.

The supply voltage for the expansion card is provided by the servo amplifier.



11.3.1 Connection technology

Cable selection, cable routing, shielding, bus connector, bus termination and transmission times are all described in the "Installation Guidelines for PROFIBUS-DP/FMS" from PNO, the PROFIBUS User Organization.

11.3.2 Connection diagram

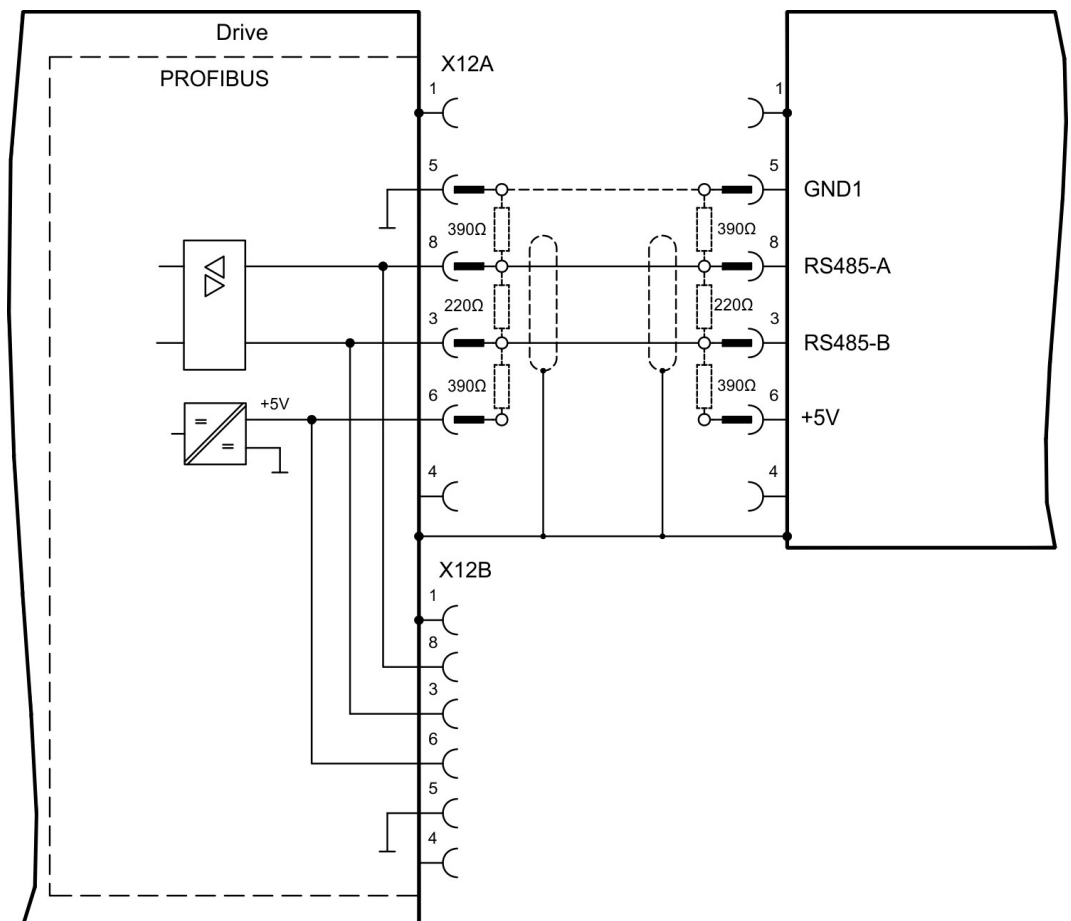

11.4 Expansion card -SERCOS-

This section describes the sercos® II expansion card for S300. Information on the range of functions and the software protocol can be found in our manual "IDN Reference Guide sercos®".



11.4.1 LEDs

RT	Indicates whether sercos® telegrams are being correctly received. In the final Communication Phase 4 this LED should flicker, since cyclical telegrams are being received.
TT	Indicates that sercos® telegrams are being transmitted. In the final Communication Phase 4 this LED should flicker, since cyclical telegrams are being transmitted. Check the station addresses for the controls and the servo amplifier if: <ul style="list-style-type: none"> • - the LED never lights up in sercos® Phase 1 or • - the axis cannot be operated, although the RT LED is lighting up cyclically.
ERR	Indicates that sercos® communication is faulty or suffering from interference. If this LED is very bright, then communication is suffering strong interference, or is non-existent. Check the sercos® transmission speed for the controls and the servo amplifier (BAUD RATE) and the fiber-optic connection. If this LED fades or flickers, this indicates a low level of interference for sercos® communication, or the optical transmitting power is not correctly matched to the length of cable. Check the transmitting power of the (physically) previous sercos® station. The transmitting power of the servo amplifier can be adjusted in the setup software DRIVEGUI.EXE on the sercos® screen page, by altering the length parameter for the cable length.

11.4.2 Connection technology

For the fiber optic cable connection, only use sercos® components to the sercos® Standard IEC 61491.

Receive data

The fiber optic cable carrying receive data for the drive in the ring structure is connected to X13 with an F-SMA connector.

Transmit data

Connect the fiber optic cable for the data output to X14 by F-SMA connector.

11.4.3 Connection diagram

Layout of the sercos® bus system in ring topology, with fiber optical cables (schematic).

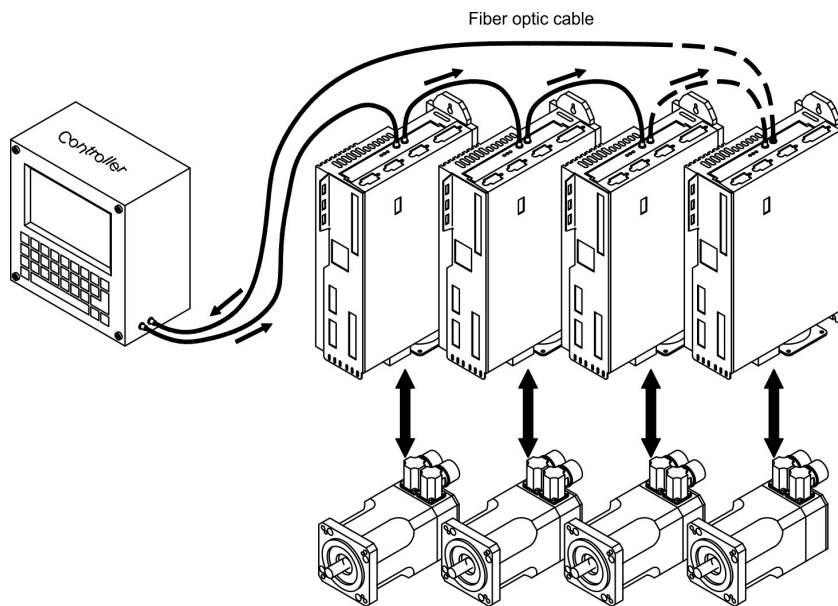

11.4.4 Setup

Modifying the station address

The drive address can be set to a value between 0 and 63. With address 0, the drive is assigned as an amplifier in the sercos® ring. Set the station address with the:

Keys on the front of the servo amplifier

The sercos® address can be modified using the keys on the front of the amplifier (→ # 109).

Setup software

The address can also be modified in the setup software, “CAN/Fieldbus” screen (please refer to the setup software [Online Help](#)). Alternatively, enter the command **ADDR #** in the “Terminal” screen, where # is the new address of the drive.

Modifying the baud rate and optical power

If the baud rate is not set correctly, communication is not possible.

The **SBAUD #** parameter can be used to set the baud rate, where # is the baud rate. If the optical power is not set correctly, errors occur in telegram transmission and the red LED on the drive lights up. During normal communication, the green send and receive LEDs flash, giving the impression that the relevant LED is on.

The **SLEN #** parameter can be used to specify the optical range for a standard 1 mm² glass fibre cable, where # is the length of the cable in meters.

SBAUD	SLEN		
2	2 Mbaud	0 m	Very short connection
4	4 Mbaud	1...< 15 m	Length of the connection with a 1 mm ² plastic cable
8	8 Mbaud	15...< 30 m	Length of the connection with a 1 mm ² plastic cable
16	16 Mbaud	≥ 30 m	Length of the connection with a 1 mm ² plastic cable

The parameters can be modified in the setup software, “SERCOS” screen (please refer to the setup software the [Online Help](#)). Alternatively, the commands **SBAUD #** and **SLEN #** can be entered in the “Terminal” screen.

11.5 Expansion card - DEVICENET -

This section describes the DeviceNet expansion card for S300. Information on the range of functions and the software protocol can be found in our manual "DeviceNet Communication Profile".

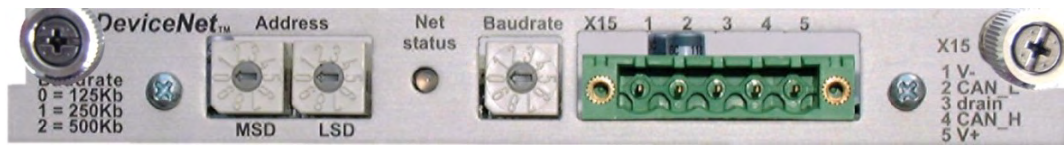

11.5.1 Connection technology

Cable selection, cable routing, shielding, bus connector, bus termination and transmission times are all described in the "DeviceNet Specification, Volume I, II", published by ODVA.

11.5.2 Connection diagram

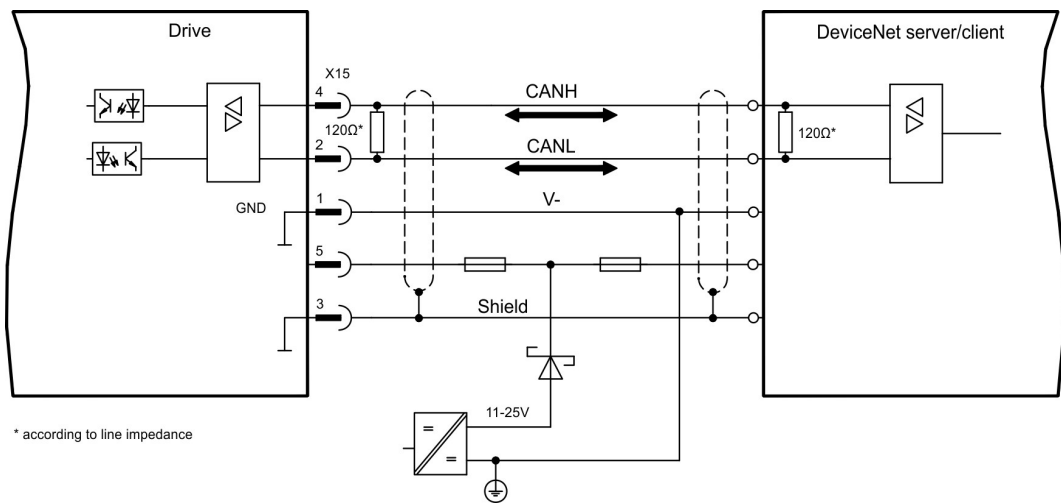

11.5.3 Combined module status and network status LED

LED	Bedeutung:
off	The device is not online. <ul style="list-style-type: none"> • The device has not yet finished the Dup_MAC_ID test. • The device is possibly not yet switched on.
green	The device is operating as normal, is online, and the connections have been established. The device has been assigned to a master.
blinking green	The device is operating as normal, is online, but the connections have not been established. <ul style="list-style-type: none"> • The device has passed the Dup_MAC_ID test and is online, but the connection to other nodes have not been established. • This device has not been assigned to a master. • Missing, incomplete or wrong configuration.
blinking red	An error that can be cleared and/or at least one I/O connection are in a waiting state.
red	<ul style="list-style-type: none"> • An error has occurred that cannot be cleared; it may be necessary to replace the device. • Communication device failure. The device has detected a fault that prevents communication with the network (for instance, a MAC ID appears twice or BUSOFF).

11.5.4 Setup

Setting the station address (device address)

The station address for the servo amplifier can be set in three different ways:

- Set the rotary switches at the front of the expansion card to a value between 0 and 63. Each switch represents a decimal figure. For example, to set the address for the drive to 10, set MSD to 1 and LSD to 0.
- Set the rotary switches at the front of the expansion card to a value higher than 63. Now you can set up the station address by using the ASCII commands DNMACID x, SAVE, COLDSTART, whereby "x" stands for the station address.
- Set the rotary switches at the front of the expansion card to a value higher than 63. Now you can set up the station address by using the DeviceNet Object (Class 0x03, Attribute 1). This is normally carried out with the help of a DeviceNet software setup tool. You must save the parameters in non-volatile memory (Class 0x25, Attribute 0x65) and then restart the drive after setting or altering the address.

Setting the transmission speed

The DeviceNet transmission speed can be set in three different ways:

- Set the rotary switch for Baud rate (at the front of the option card) to a value between 0 and 2. 0 = 125 kbit/s, 1 = 250 kbit/s, 2 = 500 kbit/s.
- Set the rotary switch for Baud rate (at the front of the option card) to a value higher than 2. Now you can set the Baud rate by using the terminal commands DNBAUD x, SAVE, COLDSTART, whereby "x" stands for 125, 250 or 500 .
- Set the rotary switch for Baud rate (at the front of the option card) to a value higher than 2. Now you can set the Baud rate by using the DeviceNet Object (Class 0x03, Attribute 2) to a value between 0 and 2. This is normally carried out with the help of a DeviceNet software setup tool. You must save the parameters in non-volatile memory (Class 0x25, Attribute 0x65) and then restart the drive after altering the baud rate.

11.5.5 Bus cable

To meet ISO 11898, a bus cable with a characteristic impedance of 120 Ω should be used. The maximum usable cable length for reliable communication decreases with increasing transmission speed. As a guide, you can use the following values which we have measured, but they are not to be taken as assured limits.

General characteristic	Specification
Bit rates	125 kBit, 250 kBit, 500 kBit
Distance with larger bus connections	500 m at 125 kBaud 250 m at 250 kBaud 100 m at 500 kBaud
Number of nodes	64
Signal environment	CAN
Modulation	Basic bandwidth
Coupling medium	DC-coupled differential transmit/receive operation
Isolation	500 V (option: optocoupler on the transceiver's node side)
Typical differential input impedance (recessive state)	Shunt C = 5pF Shunt R = 25kΩ (power on)
Min. differential input impedance (recessive state)	Shunt C = 24pF + 36 pF/m of the permanently attached stub cable Shunt R = 20kΩ
Absolute max. voltage range	-25 V bis +18 V (CAN_H, CAN_L). The voltages for CAN_H and CAN_L refer to the ground pin of the transceiver. The voltage is higher than that on the V-terminal by the amount of the forward voltage drop of the Schottky diode. This voltage drop must be < 0.6V.

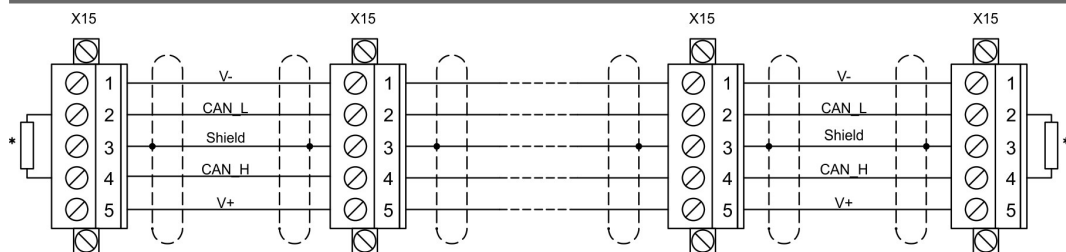

Grounding:

The DeviceNet network must only be grounded at one point, to avoid ground loops. The circuitry for the physical layer in all devices are referenced to the V-bus signal. The ground connection is made via the power supply for the bus system. The current flowing between V- and ground must not flow through any device other than the power supply.

Bus topology:

The DeviceNet medium utilizes a linear bus topology. Termination resistors are required at each end of the connecting cable. Stub cables are permitted up to a length of 6 meters, so that at least one node can be connected.

Termination resistors:

DeviceNet requires a termination at each end of the connecting cable. These resistors must meet the following requirements: 120 Ω, 1% metal-film, ¼ W

11.6 Expansion card -SYNQNET-

This section describes the SynqNet expansion card for S700. Information on the range of functions and the software protocol can be found in the SynqNet documentation.



11.6.1 NODE ID Switch

With these hexadecimal switches you can set the main and low significant bytes of the Node ID separately. SynqNet does not require an address for correct operation in the network, however in some machines this can be a convenient way of identifying build options to the application program.

11.6.2 NODE LED table

LED#	Name	Function
LED1	LINK_IN	ON = receive valid (IN port) OFF = not valid, power off, or reset.
LED2	CYCLIC	ON = network cyclic BLINK = network not cyclic OFF = power off, or reset
LED3	LINK_OUT	ON = receive valid (OUT port) OFF = not valid, power off, or reset
LED4	REPEATER	ON = repeater on, network cyclic BLINK = repeater on, network not cyclic OFF = repeater off, power off, or reset

11.6.3 SynqNet Connection, Connector X21B / X21C (RJ-45)

Connection to the SynqNet network via RJ-45 connectors (IN and OUT ports) with integrated LEDs.

11.6.4 Digital inputs and outputs, connector X21A (SubD 15-pin, socket)

Inputs (In): 24V (20...28V), opto-isolated, one high-speed input (Pin 4)

Outputs (Out): 24V, opto-isolated, Darlington driver

Pinout connector X21A (SubD 15 pin)			
Pin	Type	Description	
1	In	+24V	power supply
2	Out	NODEALARM	indicates a problem with the node
3	Out	OUT_01	digital output
4	In	IN_00 (fast)	capture input (fast)
5	In	IN_04	digital input
6	In	IN_01	digital input
7	In	HOME	reference switch
8	In	POSLIM	limit switch, positive direction
9	In	GND	power supply
10	Out	OUT_00	digital output
11	Out	OUT_02	digital output
12	In	IN_02	digital input
13	In	IN_03	digital input
14	In	NEGLIM	limit switch, negative direction
15	In	NODEDISABLE	disables Node

11.6.5 Connection diagram digital inputs and outputs, connector X21A

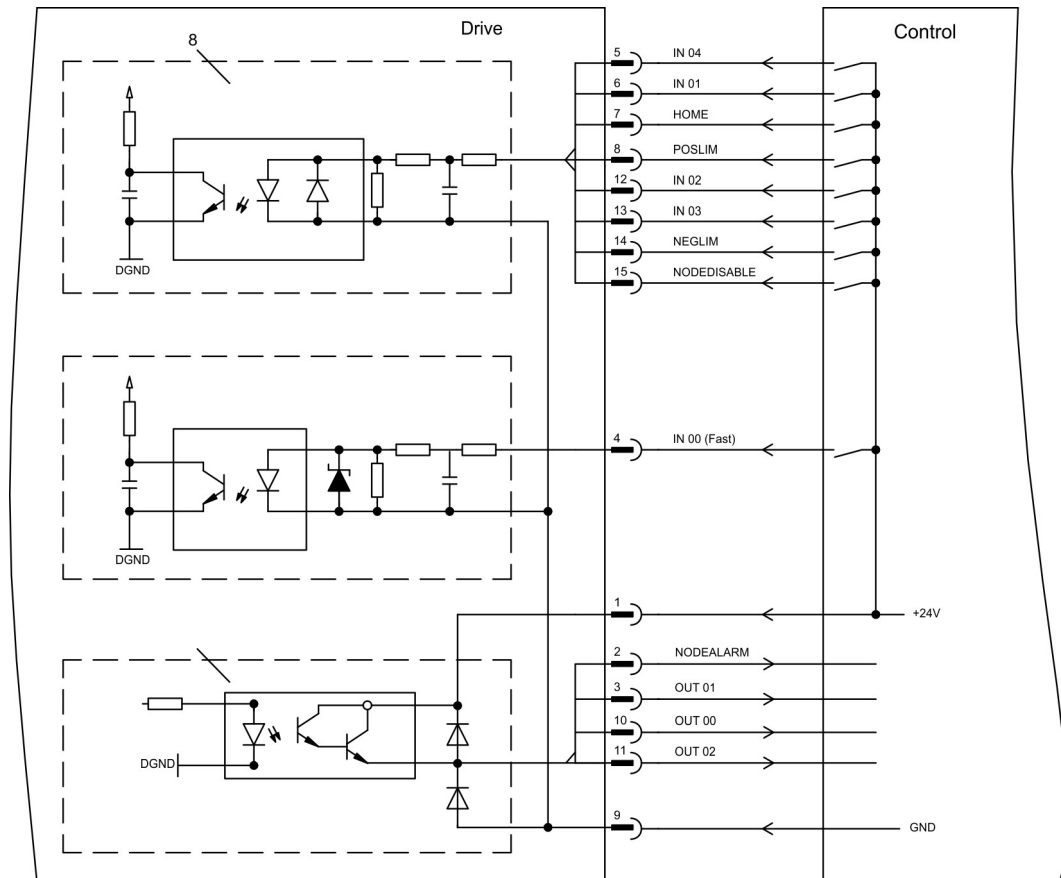

11.7 Expansion card - FB-2to1 -

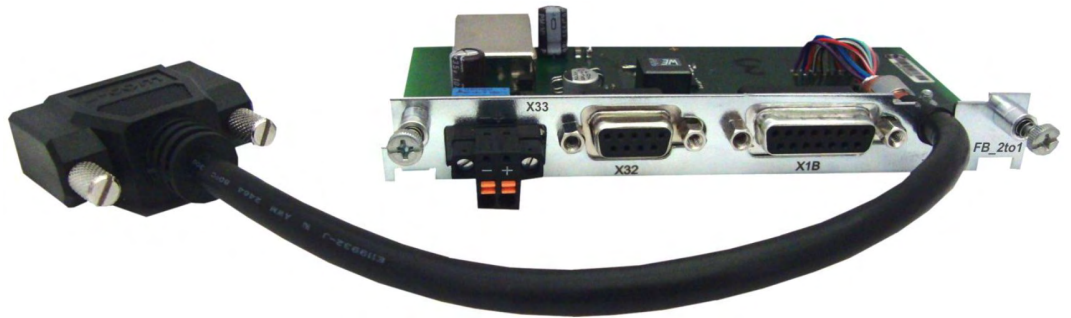

This chapter describes the Feedback extension card FB-2to1 for the S300. The card enables simultaneous connection of a digital primary and of an analog secondary feedback to the connector X1. The supply of 24V DC auxiliary voltage to X33 is converted on the extension card into a precise 5V DC encoder supply for the secondary feedback.



11.7.1 Pinout

X33	Pinout Combicon Connector
+	+24V DC (20...30V), approx. 500mA
-	GND

X32	Pinout SubD 9 poles (secondary Feedback) SinCos (1V p-p)	X1B	Pinout SubD 15 poles (primary Feedback) EnDat 2.2, BiSS digital, SSI absolute
1	B- (cosine)	1	n.c.
2	SENSE+	2	0V
3	A- (sine)	3	n.c.
4	n.c.	4	+5V DC
5	+5V DC (300mA)	5	DATA
6	B+ (cosine)	6	n.c.
7	SENSE-	7	Temperature Sensor Motor
8	A+ (sine)	8	CLOCK
9	0V	9	n.c.
-	-	10	Sense 0V
-	-	11	n.c.
-	-	12	Sense +5V
-	-	13	$\overline{\text{DATA}}$
-	-	14	Temperature Sensor Motor
-	-	15	$\overline{\text{CLOCK}}$

11.7.2 Wiring example with BiSS digital (primary) and SinCos (secondary)

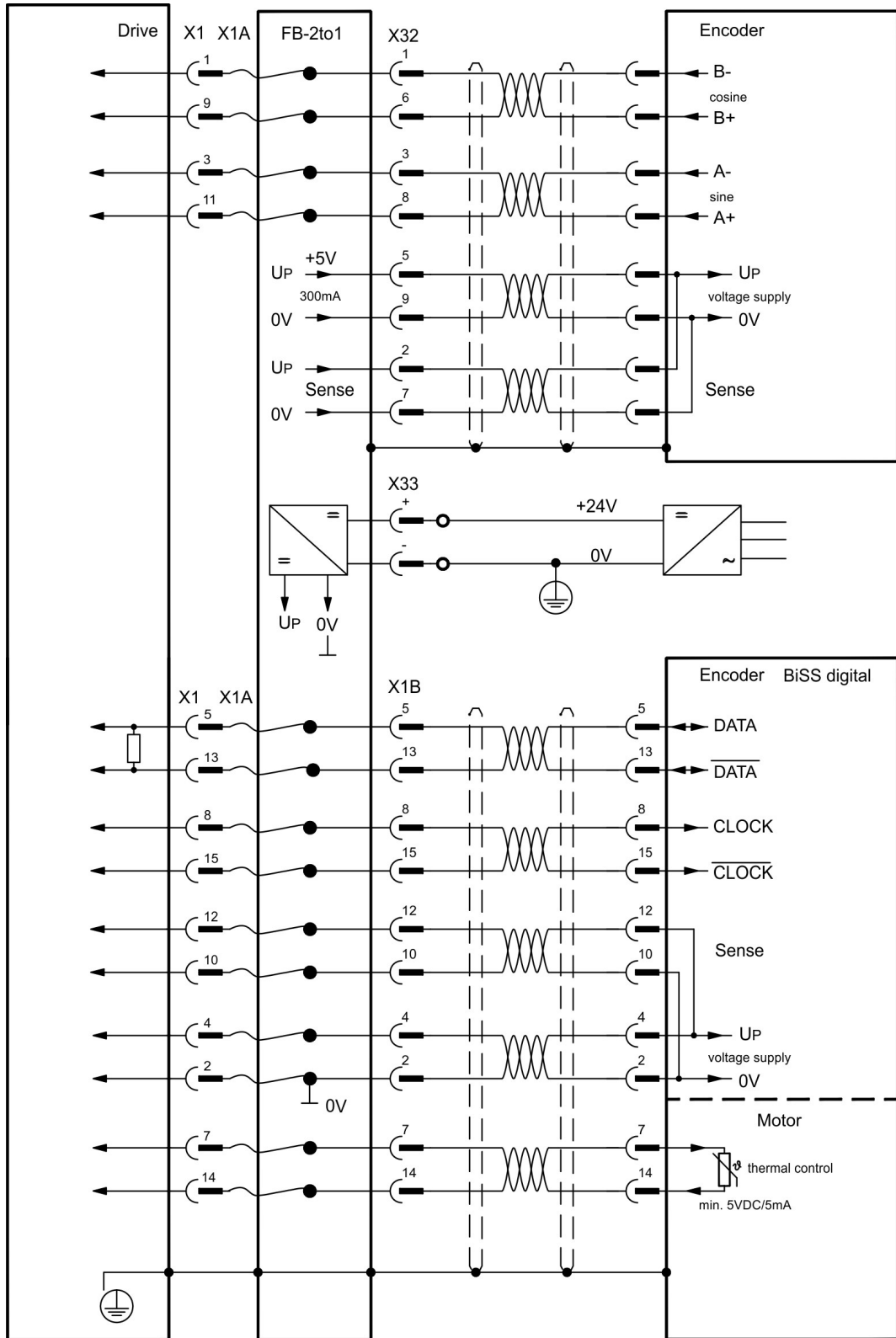

11.8 Expansion card -PROFINET-

This chapter describes the ProfiNet expansion card for the S300. You can find information on the range of functions and the software protocol in our "PROFINET Fieldbus Interface" manual. The PROFINET expansion card has a dual RJ45 PROFINET interface. The power supply for the expansion card is provided by the servo amplifier.



The PROFINET expansion card supports the following functions:

- RT
- RT / IRT Mixed operation is possible.
- LLDP
- I&M 0
- I&M 1-4

11.8.1 Device master file

The GSDML device master file can be found on the supplied CDROM or on the Kollmorgen website.

11.8.2 LED

Name	Color	Function
BF	Red	On = Bus error Off = no error Flashing 2Hz = No data is being exchanged
SF	Red	On = System error Off = no error Flashing 2Hz = DCP signal service is initiated via the bus
Power	Green	On = Supply voltage is present Off = No supply voltage
RJ45: Link / Activity	Green	On = Connection to Ethernet Off = No connection to Ethernet
RJ45: Rx/Tx	Yellow	On = Sends / receives Ethernet frames

11.8.3 Connection technology

The PROFIBUS User Organisation PNO describes the cable selection, cable routing, shielding, bus connectors, bus termination and runtimes.

Please note the following when making the PROFINET connection:

- Only use standard industrial Ethernet cable and connectors.
- Only use double-shielded twisted pair cable and shielded RJ45 connectors (industrial connectors).
- 100BaseTX cable in accordance with the Ethernet standard (min. Category 5)

11.8.4 Connection examples

Connection example for RT Network



Connection example for RT / IRT Network

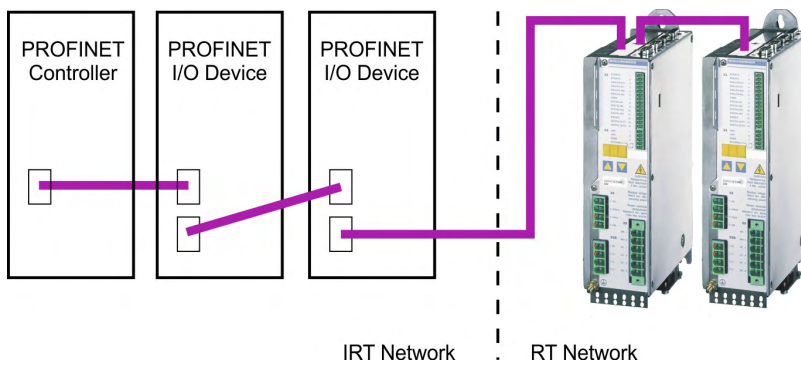

Connection example for RT / IRT Network with Switch

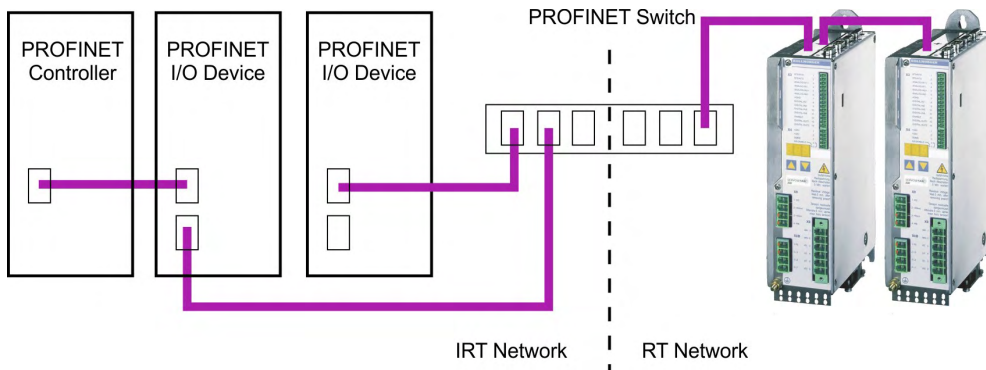

11.9 Expansion module -2CAN-

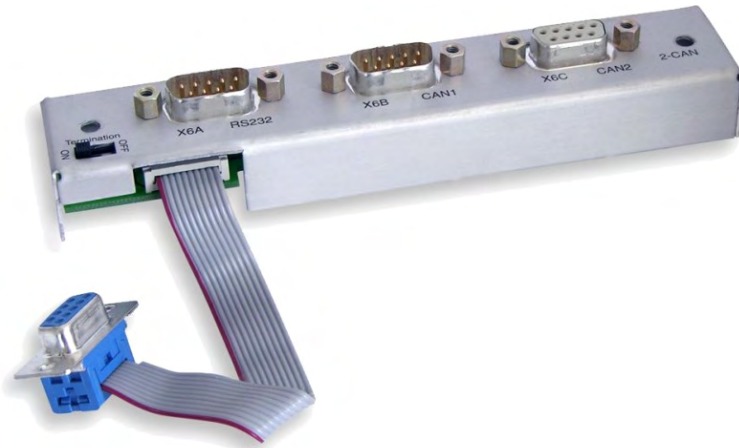

2CAN Connector X6 of the S300 is assigned to the signals for the RS232 interface and the CAN interface. It is therefore not the standard pin assignment for these interfaces, and a special cable is required to be able to use both interfaces simultaneously. The -2CAN- expansion module provides the interfaces on separate Sub-D connectors. The two CAN connectors are wired in parallel. A termination resistor (120Ω) for the CAN bus can be switched into circuit if the S300 is at the end of the bus.



11.9.1 Installation

NOTICE

Before starting work, switch off the power to the device, i.e. neither the power supply nor the 24 V auxiliary voltage nor the operating voltage of the servo amplifier or any other connected device may be switched on.

The module must be placed onto the option slot after levering off the cover of the option slot 1 (→ # 115):

NOTE

- Screw the distance pieces into the fixing lugs of the option slot.
- Place the expansion module onto the option slot.
- Screw the screws into the threads of the distance pieces.
- Plug the Sub-D9 socket into connector X6 on the S300

11.9.2 Connection technology

Standard shielded cables can be used for the RS232 and CAN interfaces.

NOTE

If the servo amplifier is the last device on the CAN bus, then the switch for the bus termination must be set to ON.

Otherwise, the switch must be set to OFF (condition as delivered).

11.9.3 Connector assignments

RS232		CAN1=CAN2	
X6A Pin	Signal	X6B=X6C Pin	Signal
1	Vcc	1	
2	RxD	2	CAN-Low
3	TxD	3	CAN-GND
4		4	
5	GND	5	
6		6	
7		7	CAN-High
8		8	
9		9	

11.9.4 Setup of Station Address and Baud Rate

During setup it makes sense to use the keypad on the front panel to preset the station addresses for the individual amplifiers and the Baud rate for communication.

NOTE

After changing the station address and baud rate you must turn the 24V auxiliary supply for the servo amplifier off and on again.

Possible ways for setup:

- keypad on the front panel of the servo amplifier
- setup software: screen page "CAN / Fieldbus"
- serial interface with a sequence of ASCII commands:
 ADDR nn => SAVE => COLDSTART (with nn = address)
 CBAUD bb => SAVE => COLDSTART (with bb = baud rate in kBaud)

Coding of the Baud rate in LED display:

Coding	Baud rate in kBit/s	Coding	Baud rate in kBit/s
1	10	25	250
2	20	33	333
5	50	50	500
10	100	66	666
12	125	80	800
		100	1000

11.10 Option "EtherCAT"

Offers EtherCAT interface to the S300. This option uses the expansion slot. Information on the range of functions and the software protocol can be found in the EtherCAT documentation. This option enables the S300 to be connected to the EtherCAT network via RJ-45 connectors (IN and OUT ports).

NOTE

The option EtherCAT cannot be inserted later. Order the amplifier with built-in EtherCAT option.

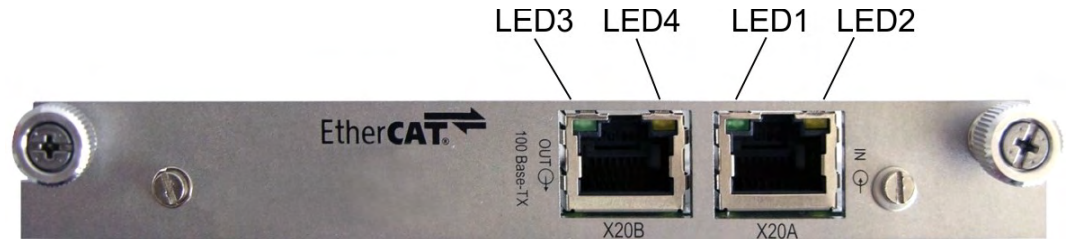

11.10.1 NODE LED table

LED#	Name	Function
LED1	LINK_IN	ON = receive valid (IN port) OFF = not valid, power off, or reset.
LED2	CYCLIC	ON = network cyclic BLINK = network not cyclic OFF = power off, or reset
LED3	LINK_OUT	ON = receive valid (OUT port) OFF = not valid, power off, or reset
LED4	REPEATER	ON = repeater on, network cyclic BLINK = repeater on, network not cyclic OFF = repeater off, power off, or reset

11.10.2 Connection diagram

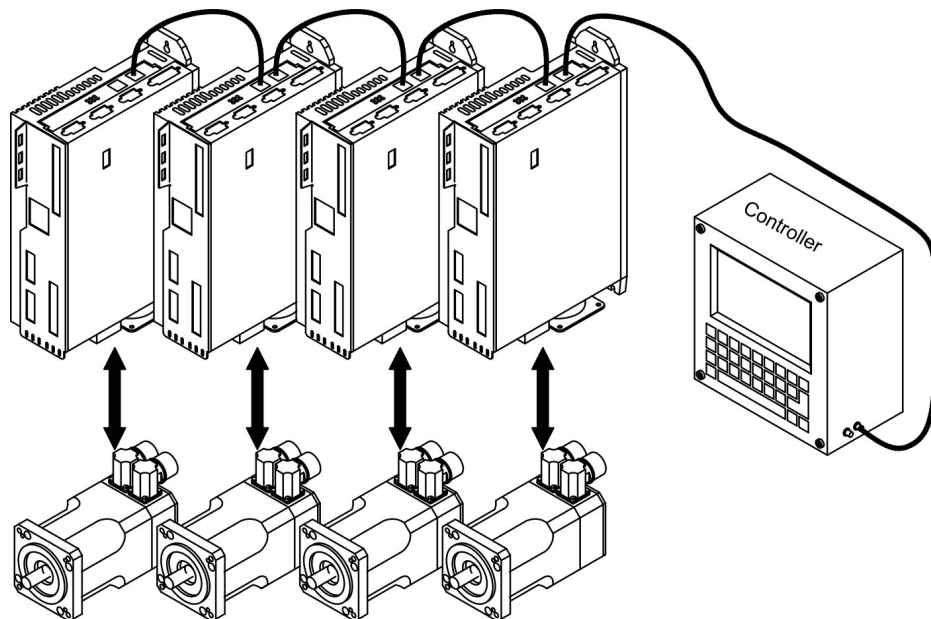

11.11 Option "FAN", ventilator control

To reduce the average noise emission of servo amplifiers with fan, these amplifiers can be ordered with built-in fan option card (ventilator control). This option uses (invisible from the outside) the expansion slot.

NOTE

The option FAN cannot be inserted later. Order the amplifier with built-in FAN option.

Function

The fan is switched on and off depending on measured temperature values and brake power. That reduces the average noise emission.

Switching temperature

Monitoring	Fan off	Fan on
Internal temperature	< 55°C	> 58°C
Heat sink temperature	< 60°C	> 65°C
Brake resistor (internal)	< 20W	> 30W

12 Appendix

12.1 Glossary

B	Brake circuit	Converts generative energy fed back by the motor during braking (generated energy) to heat.
C	Clock	Clock signal
	Common-mode voltage	The maximum amplitude of a disturbance (on both inputs) which a differential input can eliminate
	Counts	Internal count pulses, 1 pulse = $1 / 2^{20}$ turn ⁻¹
	Continuous power of brake circuit	Mean power that can be dissipated in the brake circuit
D	Current controller	Regulates the difference between the current setpoint and the actual value to 0 Output : power output voltage
	DC bus link	Rectified and smoothed power voltage
	Disable	Removal of the ENABLE signal
	Earth short	electrical connection between a phase and the protective earth (PE)
E	Enable	Enable signal for the servo amplifier, Hardware-Enable with 24V signal to X3, Software-Enable command by setup Software, fieldbus or permanently set. Both are required for enabling the amplifier.
	ENABLE	Enable signal for the servo amplifier (+24 V)
F	Fieldbus interface	CANopen, PROFIBUS, SERCOS etc.
	Final speed (limit speed)	Maximum value for the speed normalization at ± 10 V
G	GRAY-code	Special format for representing binary numbers
H	Holding brake	Brake in the motor, that can only be used when the motor is at standstill
I	I ² t threshold	Monitoring of the r.m.s. current that is actually required
	Input drift	Temperature and age-dependent alteration of an analog input
	Incremental encoder interface	Position signaling by 2 signals with 90° phase difference (i.e. in quadrature), is not an absolute position output
	I _{peak} , peak current	The effective value of the peak current
	I _{rms} , effective current	The r.m.s. value of the continuous current
K	K _p , P-gain	Proportional gain of a control loop
L	Limit speed (final speed)	Maximum value for speed normalization at ± 10 V
	Limit switch	Switch limiting the traverse path of the machine; implemented as n.c. (break) contact
M	Machine	The complete assembly of all connected parts or devices, of which at least one is movable
	Motion block	Data packet with all the position control parameters which are required for a motion task
	Multi-axis system	Machine with several independently driven axes
N	Natural convection	Free movement of air for cooling
O	Optocoupler	Optical connection between two electrically independent systems

P	P-controller	Control loop with purely proportional behavior
	Phase shift	Compensation for the lag between the electromagnetic and magnetic fields in the motor
	PI-controller	Control loop with proportional and differential behavior
	Position controller	Regulates the difference between the position setpoint and the actual position to 0 Output: speed setpoint
	Potential isolation	electrically decoupled, electrical isolation
	Power contactor	System protection device with phase monitoring
	Pulse power of the brake circuit	Maximum power which can be dissipated in the brake circuit
R	Reset	New start of the microprocessor
	Resolver to Digital converter	Conversion of the analog resolver signals into digital information
	Reversing mode	Operation with a periodic change of direction
	Ring core	Ferrite rings for interference suppression
S	ROD-interface	Incremental position output
	Servo amplifier	Control device for regulating the speed, torque and position of a servomotor
	Setpoint ramps	Limits for the rate of change of the speed setpoint
	Short-circuit	here: electrically conductive connection between two phases
	Speed controller	Regulates the difference between the speed setpoint and the actual value to 0 Output : current setpoint
	SSI-interface	Cyclically absolute, serial position output
	Supply filter	Device to divert interference on the power supply cables to PE
	Tachometer voltage	Voltage proportional to the actual speed
Z	Thermal control	Temperature-sensitive device built into the motor winding (usually PTC)
	T _n , I-integration time	Integral component of a control loop
	Zero pulse	Output once per turn from incremental encoder, used to zero the machine

12.2 Order codes

The order numbers of accessories such as cables, brake resistors, mains supplies, etc., can be found in the accessories manual.

Servo amplifiers

Article	Rated voltage	Order code*
SERVOSTAR 303	110-230 V AC	S30361-NA
SERVOSTAR 303-EC	110-230 V AC	S30361-EC
SERVOSTAR 306	110-230 V AC	S30661-NA
SERVOSTAR 306-EC	110-230 V AC	S30661-EC
SERVOSTAR 306-FAN	110-230 V AC	S30661-FN
SERVOSTAR 310	110-230 V AC	S31061-NA
SERVOSTAR 310-EC	110-230 V AC	S31061-EC
SERVOSTAR 310-FAN	110-230 V AC	S31061-FN
SERVOSTAR 341	208-480 V AC	S30101-NA
SERVOSTAR 341-EC	208-480 V AC	S30101-EC
SERVOSTAR 343	208-480 V AC	S30301-NA
SERVOSTAR 343-EC	208-480 V AC	S30301-EC
SERVOSTAR 343FAN	208-480 V AC	S30301-FN
SERVOSTAR 346	208-480 V AC	S30601-NA
SERVOSTAR 346-EC	208-480 V AC	S30601-EC
SERVOSTAR 346-FAN	208-480 V AC	S30601-FN

* NA : without built-in expansion card

FN : built-in FAN option, uses expansion slot

EC : built-in EtherCAT option, uses expansion slot

Expansion cards

Article	EU Order code	US Order code
Expansion card DeviceNet	DE-103571	OPT-DN
Expansion card PROFIBUS DP	DE-106712	OPT-PB3
Expansion card PROFINET	DE-202223	OPT-PN
Expansion card SERCOS	DE-90879	OPT-SE
Expansion card I/O-14/08	DE-90057	OPT-EI
Expansion card EtherCAT old)	DE-108350	OPT-EC
Expansion card SynqNet	DE-200073	OPT-SN
Expansion card FB-2to1	DE-201664	-
Expansion module 2CAN	DE-101174	-

Mating connectors

Article	EU Order code	US Order code
Mating connector X3	DE-107554	CON-S3X3
Mating connector X4	DE-107555	CON-S3X4
Mating connector X0 (110...230V)	DE-105856	CON-S3X0L
Mating connector X8 (110...230V)	DE-107556	CON-S3X8L
Mating connector X9 (110...230V)	DE-107631	CON-S3X9L
Mating connector X0 (208...480V)	DE-107557	CON-S3X0H
Mating connector X8 (208...480V)	DE-107558	CON-S3X8H
Mating connector X9 (208...480V)	DE-107467	CON-S3X9LH

-- / --

13 Index

2

24V auxiliary supply, interface 59

A

Abbreviations 11
Ambient Conditions 29
Approvals 19
Auxiliary voltage 28

B

Baudrate
 2CAN 132
 CAN 96, 109
 Devicenet 123
 SERCOS 121
BiSS Encoder analog, interface 70
BiSS Encoder digital, interface 71
Block diagram 54
Brake resistor
 Technical Data 32
Brake Resistor
 Interface 61
Brake, motor brake 30
BTB/RTO 94

C

CAN Bus
 Cable 96
 Interface 96
Capacitor Module 62
ComCoder 80
Conductor cross-sections 29
Conformance
 EAC 21
 REACH 21
 RoHS 21
 UL and cUL 19
Connectors 28
cUL 19

D

DC bus link, interface 61
Decommission 17
Devicenet bus cable 124
Dimensions
 Standard Width 47
Disassemble 17
Disposal 18
DSL, interface 68

Dynamic braking 31

E

EAC 21
Electronic Gearing
 X1 87
Emergency Off 37
Emergency Stop 37
Encoder-Emulation
 X5 90
EnDat 2.1 Encoder, X1 72
EnDat 2.2 Encoder, X1 73
Error messages 112
Expansion card
 -2CAN- 131
 -DEVICENET- 122
 -FB-2to1- 127
 -PROFIBUS- 119
 -PROFINET- 129
 -SERCOS- 120
 -SYNQNET- 125

F

Feedback systems 65
Feedback types 66
Fusing 28

G

Glossary 135
Ground symbol 50
Grounding
 Installation 49
Grounding system 31

H

Hall, X1 86
Hardware requirements 99
Hiperface Encoder, interface 74

I

Inputs
 Analog-In 1/2 92
Inputs / outputs 28
Installation
 Electrical 48
 Expansion cards 115
 Mechanical 45
 Software 99
Installation, Setup, Normal Operation 16
Isolating transformers 44

K

Keypad operation 109

L

Leakage current 44

LED Display 31, 109

M

Maintenance 17

Master-Slave X1 89

Motor brake 30

Motor, interface 64

Mounting 46

N

Nameplate 22

Node Address

2CAN 132

CAN-Bus 109

Devicenet 123

SERCOS 121

O

Operating systems 99

Optical power 121

Option "FAN" 134

Option EtherCAT 133

Order codes 137

Outputs

BTB/RTO 94

Digital-Out 1/2 94

P

Packaging 16

Package Supplied 22

Part Number Scheme 23

Position output X5 90

Q

Quickstart, initial drive test 100

R

REACH 21

Repair 18

Residual current protective device 44

Resolver, interface 69

ROD (AquadB) 24V with Hall, X3/X1 84

ROD (AquadB) 24V, X3 83

ROD (AquadB) 5V with Hall, X1 80

ROD (AquadB) 5V, 1.5MHz avec Hall, X5/X1 82

ROD (AquadB) 5V, 1.5MHz, X1 78

ROD (AquadB) 5V, 1.5MHz, X5/X1 81

ROD (AquadB) 5V, 350kHz, X1 79

ROD Emulation X5 90

RoHS 21

S

Safe Torque Off 38

Setpoint inputs 92

Setup Wizard 104

SFD3, interface 67

Shielding 49

Shielding connection 51

Shock-hazard protection 44

SinCos+SSI at X5/X1 75

Sine Encoder with Hall 77

Sine Encoder without data channel 76

SSI Emulation X5 91

SSI Encoder X5/X1 85

Step/Direction 24V at X3 88

Step/Direction 5V at X1 88

Step/Direction 5V at X5 89

STO 38

Stop 36

Storage 16

Supply connection, interface 59

Supply networks 58

Switch-on and switch-off behavior 33

Symbols used 10

System components, Overview 53

T

Technical Data 26

Tightening Torques 28

Transport 16

Trouble shooting 114

U

UL 19

Use as directed

Setup Software 98

STO 40

Use as Directed

General 15

V

Ventilation 29

W

Warning messages 113

Wiring 50

14 Record of document revisions

Revision	Remarks
06/2004	First edition
04/2005	Restart lock -AS-, UL-listing, new pinning for X8, several corrections
04/2005a	Order numbers 400V types for NA updated
11/2005	Chapter 1 updated, ComCoder corrected, Acuro(BISS)-Interface new, max. station address 127, motor choke changed, SynqNet&EtherCAT expansion cards new, chapter 6 restructured, order codes restructured
12/2005	Feedback section, termination resistors X1/X5, CE section
02/2006	Error messages and warnings updated, additional information (SERCOS), AWG cross-sections added, inch dimensions added, analog-in circuit updated, cross section (awg)
05/2006	CAN baud rate coding updated, LED display structure updated, input analog-in updated, BISS interface updated, hardware revision added, Errors/Warnings updated
09/2006	New document structure, new cover design, warning n24, Quickstart integrated
03/2007	New part number scheme, termination resistors CAN interface and X5 corrected, branding updated, chapter leakage current new, chapter "servo system graphics" expanded and moved, chapter "various mains supply networks" moved, trouble shooting reduced, Feedback expanded and restructured, enc emulation, DC-Link expanded, AS restructured, accessories removed
07/2007	Timing diagram motor brake, standards updated (EMC and LVD)
10/2007	Target group, use as directed, standards
05/2008	Safety symbols acc. to ANSI Z535.6, repair, deinstallation, dU/dt info, syntax: "regen" => "brake", techn. data connectors, cable requirements, data brake circuit
06/2008	EC Declaration new, Hiperface corrected, option FAN new
10/2008	SCCR -> 42kA
02/2009	Product brand, single phase operation, repair/disposal request form
05/2010	SSI input clock signal inverted, Gost-R, CE, FAN, AS->STO, Emergency Stop samples=>WIKI
07/2010	Wiki Links updated
11/2010	New CPU, Ethercat Interface, Multi-Feedback
12/2010	New company name and address, CE certificate, name plate, fax form
05/2011	Option EF new, BiSS C, BiSS analog/digital separated, nameplate, front label
09/2011	Permitted switch on/off frequency defined, unsupported Feedbacks 25/26 removed, certificates
06/2012	Fusing corrected, expansion card FB2to1 new, Emergency Stop updated, Option EF removed
07/2014	Feedback - ENCVON note, FBTYPE 34, KCM modules, CE declaration of conformity, BiSS C Renishaw, diagram "Behavior in the event of an error" updated, hint automatic restart, fault table, SSI emulation timing updated, safe to touch voltage 40V->60V, wiring thermo sensor updated (Feedback)
12/2014	CE declaration of conformity removed, GOST-R & Safety certificates removed, HWR, export classification
02/2015	EAC certification, nameplate with EAC sign, UL/cUL Markings in EN+FR
12/2015	KCM wiring corrected, chapter approvals restructured, delivery pack updated, Fax form removed, safe to touch voltage 60V->50V, LVD 2014-35-EG, EMCD 2014-30-EG
02/2017	Single cable connection SFD3 / Hiperface DSL, warning notes, handling separate chapter, PFH value
04/2018	X1 connector (male->female), HR table updated, Wiki links migrated to KDN, ventilation corrected
11/2018	Layout of the warning notes updated, user expertise updated, new readers note on cover page
05/2020	Layout updated, chapter "Used Standards" removed, motor temperature sensor generalized, chapter normal operation added, RoHS, REACH, EAC, PROFINET expansion card

Service

We are committed to quality customer service. In order to serve in the most effective way, please contact your local sales representative for assistance.

If you are unaware of your local sales representative, please contact the Customer Support.



Join the [Kollmorgen Developer Network](#) for product support. Ask the community questions, search the knowledge base for answers, get downloads, and suggest improvements.



Europe

KOLLMORGEN

Internet: www.kollmorgen.com/en-us

E-Mail: technik@kollmorgen.com

Tel.: +49 - 2102 - 9394 - 0

Fax: +49 - 2102 - 9394 - 3155



North America

KOLLMORGEN

Internet: www.kollmorgen.com/en-us

E-Mail: support@kollmorgen.com

Tel.: +1 - 540 - 633 - 3545

Fax: +1 - 540 - 639 - 4162



South America

KOLLMORGEN

Internet: www.kollmorgen.com/pt-br

E-Mail: contato@kollmorgen.com

Tel.: +55 - 11 - 4615-6300



Asia

KOLLMORGEN

Internet: www.kollmorgen.cn

E-Mail: sales.china@kollmorgen.com

Tel: +86 - 400 668 2802

Fax: +86 - 21 6248 5367

