

**MICRON**

# TRUE Planetary™ Gearheads

UltraTRUE™, ValueTRUE™, NemaTRUE™, DuraTRUE™,  
EverTRUE™ and XTRUE™

Installation and Mounting Manual

09/2008

Keep all product manuals as a product component during the life span of the product.

Pass all product manuals to future users/owners of the product.

GH INST\_2008-09  
P/N 86-113-453  
DM-Issue 2

 **DANAHER**  
MOTION

**Record of Revisions**

<b>Edition</b>	<b>Valid for</b>	<b>Description</b>
09/18/08	UltraTRUE, ValueTRUE, NemaTRUE, DuraTRUE, EverTRUE and XTRUE Planetary Gearheads	Updated installation and mounting manual for all Micron TRUE Planetary™ Gearheads

Trademarks:

TRUE Planetary™

RediMount™

Gearhead Express™

UltraTRUE™

ValueTRUE™

NemaTRUE™

DuraTRUE™

EverTRUE™

XTRUE™

Technical changes to improve the performance of the equipment may be made without notice !  
Printed in USA.

All rights reserved. No part of this work may be reproduced in any form (by printing, photocopying, microfilm or any other method) or processed, copied or distributed by electronic means without the written permission of Danaher Motion

<b>1. Introduction</b>	
1.1. RediMount™ System .....	4
1.2. RediMount™ Design .....	4
1.3. Gearhead Express™ Program.....	4
<b>2. Recommended Tools.....</b>	<b>5</b>
<b>3. Pre-Installation Inspection .....</b>	<b>5</b>
<b>4. Mounting and Installation Procedure .....</b>	<b>5</b>
4.1. Warning! .....	5
4.2. Preparation.....	5
4.3. Bushing Installation .....	5
4.4. Hub Positioning .....	5
4.5. Motor Orientation .....	5
4.6. Keyway.....	5
4.7. Pre-Torque Hub Bolt Tightening .....	5
4.8. Bolt Gearhead to Motor.....	5
4.9. Final Torque Hub Bolt Tightening .....	5
<b>5. Hub Bolt Tightening Torques .....</b>	<b>6</b>
5.1. Torque Table.....	6
<b>6. Maintenance .....</b>	<b>6</b>
<b>Micron Product Overview .....</b>	<b>7</b>

# 1. Introduction

1.1. **RediMount™ System** - Micron True Planetary™ gearhead products combine precise speed reduction and torque multiplication with ease of installation using the innovative RediMount system. The most flexible mounting system in the world, the RediMount allows error free mounting to any motor in just a few simple steps. It's easy to use system features a specifically designed input housing and sleeve to accommodate all motor mounting dimensions.

1.2. **RediMount™ Design** - The Micron RediMount design provides:

- A self aligning hub to maintain concentricity between motor shaft and gearhead.
- All of the hardware required to mount up to your motor.
- A pre-installed pinion to eliminate setting procedure.
- A modular design to allow separate stocking of the gearhead and mounting kit.
- Flexibility in changing to alternate motors in the field.
- Interchangeability. The RediMount is not product specific so the same mounting kit is used across all of Micron's product lines. If you have a mounting kit for any specific motor, that same kit is used for every Micron gearhead of that frame size, every ratio and in both in-line and right angle.



1.3. **Gearhead Express™ Program** - Because of the flexibility of the RediMount system, Micron is able to offer industry best lead times and the ability to ship the most popular sizes and ratios in 24 hours with the **Gearhead Express** Program.

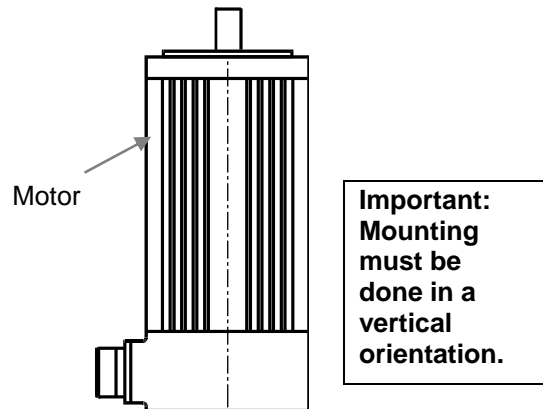
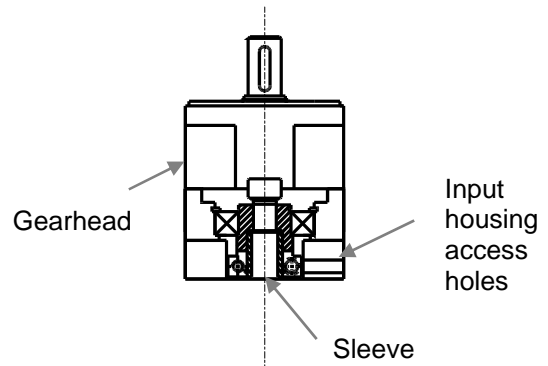

## 2. Recommended Tools

- 2.1. (1) Torque wrench with hex drive per Table 5.1.

## 3. Pre-Installation Inspection

- 3.1. Examine the unit for any damage, which may have occurred during shipping. Check the unit to ensure it meets your application's requirements, such as shaft fit and ratio. In addition, make sure all parts are clean and free of any foreign material prior to assembly.

## 4. Mounting and Installation Procedure

- 4.1. **⚠ WARNING** Whenever attempting to install this type of product, it is strongly recommended that the motor be put in a safe condition (power-off) prior to servicing. Failure to follow the instructions in this manual may result in product damage, equipment damage, and serious or fatal injury to personnel.
- 4.2. **Preparation** - Degrease motor shaft, input hub, bushing and mounting surfaces.
- 4.3. **Bushing Installation** - Slide the provided bushing into the input hub and align the slot in the bushing with the slot in the hub (a bushing may not be required or may already be installed).
- 4.4. **Hub Positioning** - Rotate the hub to align the access holes with the hub clamping bolts.
- 4.5. **Motor Orientation** - Set the motor on a work surface or holding fixture with the **OUTPUT SHAFT FACING STRAIGHT UP**. Mounting the gearhead to the motor in any other orientation will usually lead to misalignment, a load on the input bearing and excessive noise. *Note: Once mounted, the gearhead can be used in any orientation.*
- 4.6. **Keyway** - If there is a keyway on the motor shaft, remove the key, align the keyway with the slot in the hub and slide the gearhead down onto the motor shaft (it is normal and by design that the RediMount pilot bore is oversized compared to the motor pilot).
- 4.7. **Pre-Torque Hub Bolt Tightening** - Tighten BOTH hub bolts to the pre-torque value indicated on Table 5.1.
- 4.8. **Bolt Gearhead to Motor** - Bolt the gearhead to the motor using the provided hardware.
- 4.9. **Final Torque Hub Bolt Tightening** - Gradually tighten the hub bolts in three steps, increasing the torque each time. The final torque of the hub bolts should be consistent with the value indicated in Hub Bolt Tightening Torques Table 5.1

## 5. Hub Bolt Tightening Torques

### 5.1. Torque Table

Gearhead Model	Gearhead Frame Size	Pre-Tightening Torque		Final Tightening Torque	
		in-lb	[Nm]	in-lb	[Nm]
DuraTRUE™ NemaTRUE™	23/60	2	0,2	39	4,4
	34/90	4	0,4	76	8,5
	42/115	16	1,8	316	36,0
	142	32	3,6	636	72,0
UltraTRUE™ ValueTRUE™ EverTRUE™	60	2	0,2	39	4,4
	75	4	0,4	76	8,5
	90	4	0,4	76	8,5
	100	16	1,8	316	36,0
	115	16	1,8	316	36,0
	140	32	3,6	636	72,0
	180	55	6,3	1104	125,0
	220	55	6,3	1104	125,0
XTRUE™	40	0.5	0,05	9.6	1,09
	60	2	0,2	39	4,4
	80	4	0,4	76	8,5
	120	16	1,8	316	36,0
	160	32	3,6	636	72,0

Right angle versions of units above will use same mounting procedure and tightening torques.

## 6. Maintenance

6.1. All Micron planetary gearheads are grease filled and lubricated for life with no maintenance required.

## Micron Product Overview

Micron has the largest selection of True Planetary gearhead products in the world. With over 2000 size and ratio combinations to choose from, Micron will have the gearing solution for almost any application. Even with all of standard products to choose from in the catalog, Micron welcomes modification requests to existing designs as well as "white sheet of paper" custom opportunities.

### NEW!

#### The XTRUE™

High Performance, competitive drop in replacement, economical price.

#### Features

Precision: 13 arc-min  
 Frame Sizes: 40, 60, 80, 120, 160mm  
 Torque Capacity: Up to 876 Nm  
 Ratio Availability: 3:1-100:1



### NEW!

#### The ValueTRUE™

High performance, Helical Crowned True Planetary gearhead - high torque capacity, economical price.

#### Features

Precision: 4 arc-min  
 Frame Sizes: 60, 75, 90, 100, 115, 140, 180, 220mm  
 Torque Capacity: Up to 2969 Nm  
 Ratio Availability: 4:1-100:1 (up to 50:1 on right angle).



#### The UltraTRUE™

Helical Crowned True Planetary gearhead, highest torque capacity per frame size.

#### Features

Precision: 4 arc-min  
 Frame Sizes: 60, 75, 90, 100, 115, 140, 180, 220mm  
 Torque Capacity: Up to 3,300 Nm  
 Ratio Availability: 4:1-100:1 (up to 50:1 on right angle).



#### The EverTRUE™

Designed specifically for high speed, continuous duty applications.

#### Features

Precision: 4-arc-min  
 Frame Sizes: 100, 140, 180mm  
 Continuous Duty Torque Capacity: 1,010 Nm  
 Ratio Availability: 4:1-100:1



#### The DuraTRUE™

High precision, competitive drop-in replacement.

#### Features

Dual and Hollow output shaft options available on right angle product.  
 Precision: 8 arc-min  
 Frame Sizes: 60, 90, 115, 142mm  
 Torque Capacity: Up to 865 Nm  
 Ratio Availability: 3:1-100:1 (up to 500:1 standard on right angles)



#### The NemaTRUE™

An economical, high precision, True Planetary solution

#### Features

Available in both English and Metric Frame sizes  
 Precision: 13 arc-min  
 Frame Sizes: 23, 34, 42 (60, 90, 115mm)  
 Torque Capacity: Up to 255 Nm  
 Ratio Availability: 3:1-100:1 (up to 500:1 standard on right angles)



**Sales and Service**

We are committed to quality customer service. In order to serve in the most effective way, please contact your local sales representative for assistance. If you are unaware of your local sales representative, please contact us.

**North America****Danaher Motion Customer Support North America**

E-mail: DMAC@danahermotion.com

Phone: 1-540-633-3400

Fax: 1-540-639-4162

[www.danahermotion.com](http://www.danahermotion.com)

