

REVISION				
REV	ECN NO.	DESCRIPTION	DATE	APPROVED
A	R01.16836	SEE ECO	ALM 3/26/15	LW

- NOTES:
- MOTOR SUPPLIED AS TWO SEPARATE COMPONENTS: ARMATURE & SENSOR ASSEMBLY AND FIELD ASSEMBLY
 - FOR A C.W. ROTATION, AS VIEWED FROM LEAD END, ENERGIZE PER EXCITATION SEQUENCE TABLE.
 - R= 1.5K OHMS APPROX. (CUSTOMER SUPPLIED)
 - V-AB, V-BC AND V-CA IS BACK EMF OF MOTOR PHASES AB, BC AND CA RESPECTIVELY, ALIGNED WITH SENSOR OUTPUT AS SHOWN FOR C.W. ROTATION ONLY.
 - MOUNTING SURFACE IS BETWEEN $\phi 74.68$ [2.940] AND $\phi 75.95$ [2.990] ON BOTH SIDES.
 - SENSORS SET FOR BI-DIRECTIONAL ROTATION.
 - DIMENSIONS IN BRACKETS [] ARE IN INCHES AND ARE FOR REFERENCE ONLY.
 - MIN. BEND RADIUS FOR MOTOR LEADS IS 6.90 [1.27]. MIN. BEND RADIUS FOR SENSOR LEADS IS 3.90 [1.15].

MOTOR LEADS:
 #18 AWG TEFLON, COATED, PER MIL-W-22759/11, 3 LEADS, 400 mm [15.75"] MIN. LONG EACH, 1-RED, 1-WHITE & 1-BLACK

SENSOR LEADS:
 #26 AWG, TYPE "ET", TEFLON, COATED PER MIL-W-16878, 5 LEADS, 400 mm [15.75"] MIN. LONG EACH, 1-BLUE, 1-BROWN, 1-GREEN, 1-ORANGE & 1-YELLOW

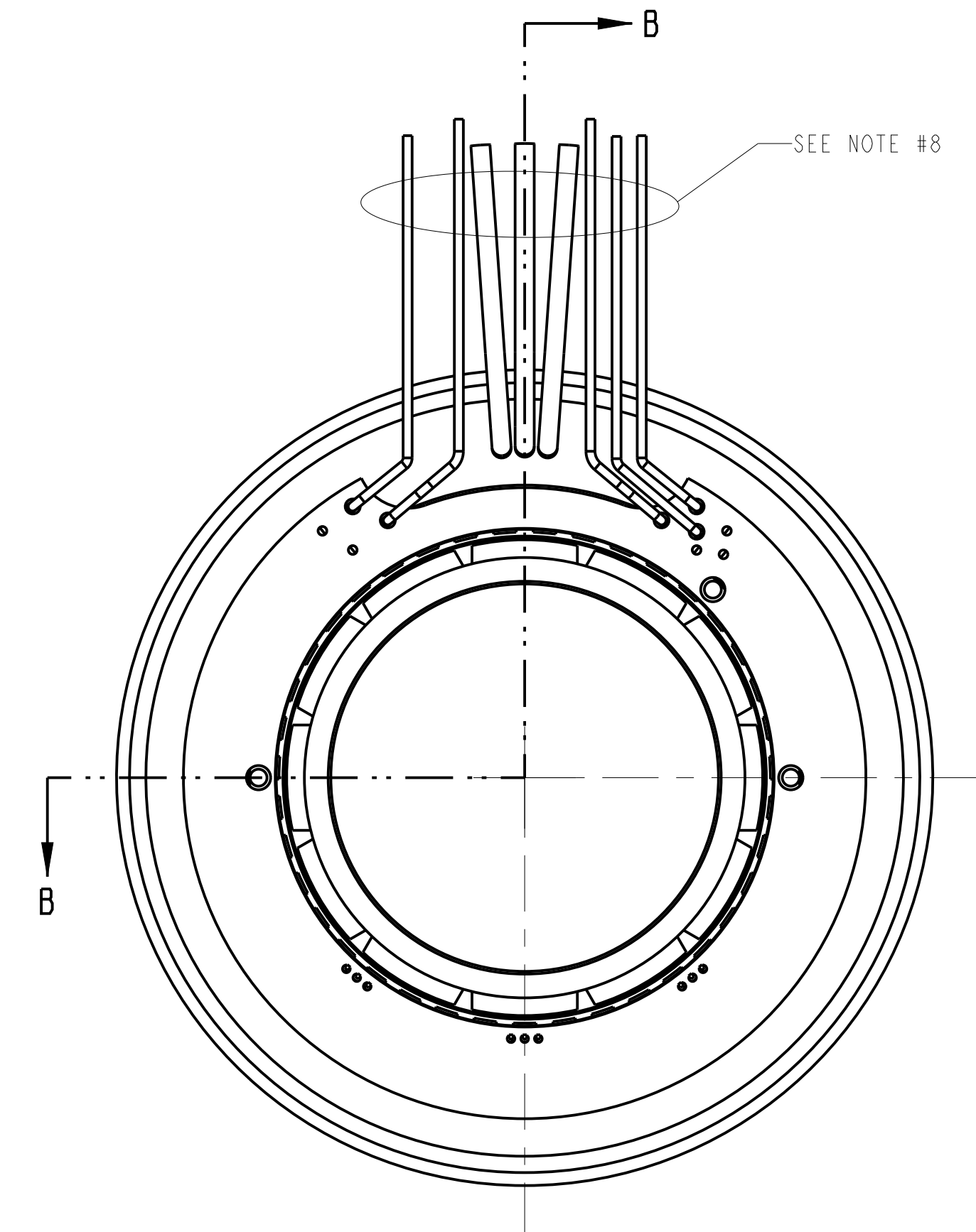
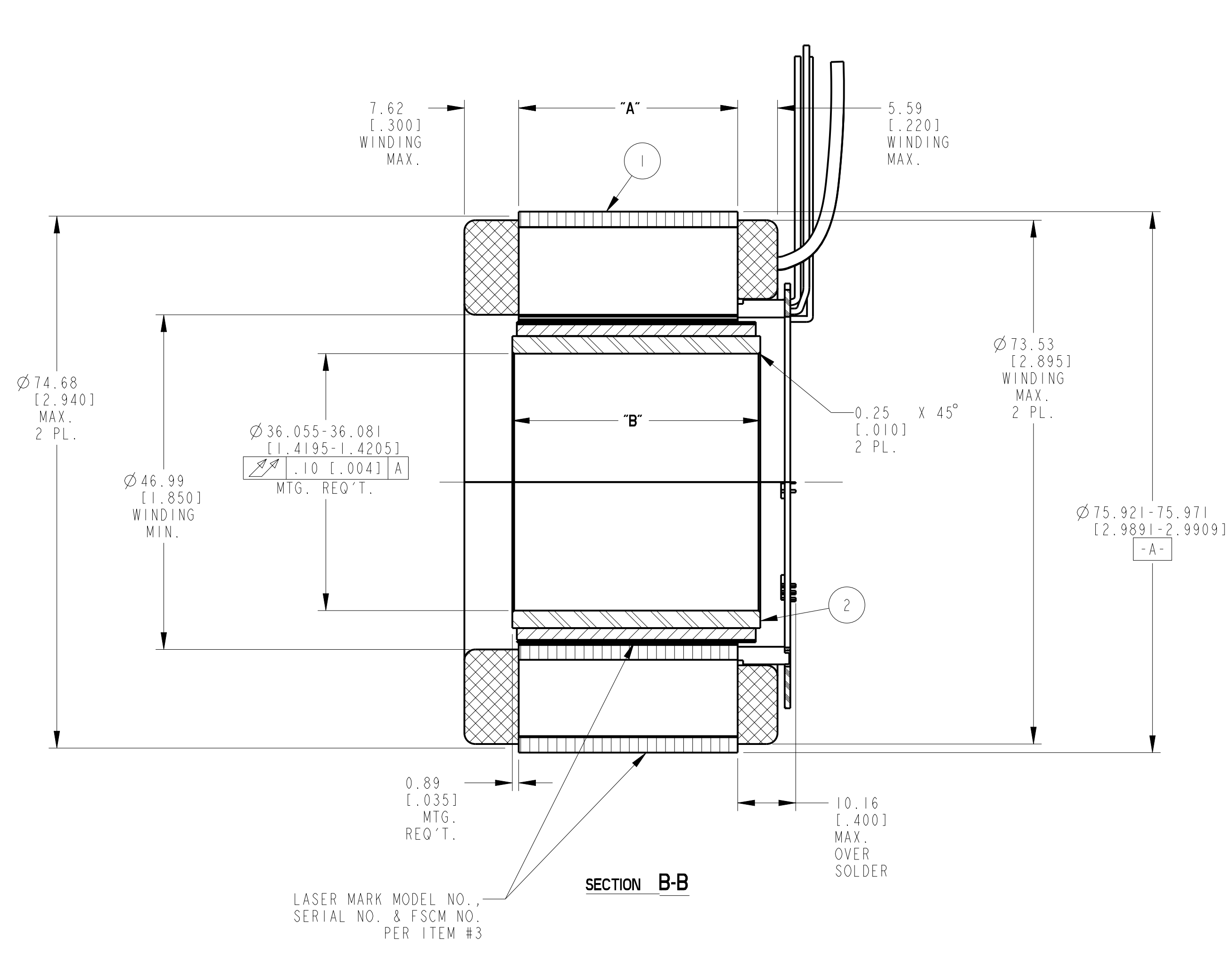

MOTOR WIRING DIAGRAM	
PHASE "A"	RED LEAD
PHASE "B"	WHITE LEAD
PHASE "C"	BLACK LEAD

MODEL NUMBER	ARMATURE & SENSOR ASSY.	FIELD ASSY.	"A" DIM.	"B" DIM.
TBMS-7615	961003/015	961005/015	14.99-15.49 [0.590-.610]	19.30 [0.760]
TBMS-7631	961003/031	961005/031	30.48-30.99 [1.200-1.220]	34.80 [1.370]
TBMS-7646	961003/046	961005/046	45.97-46.48 [1.810-1.830]	50.29 [1.980]

STEP	RED	WHITE	BLACK
1	+	-	-
2	+	-	-
3	-	+	-
4	-	+	-
5	-	-	+
6	-	-	+

EXCITATION SEQUENCE TABLE

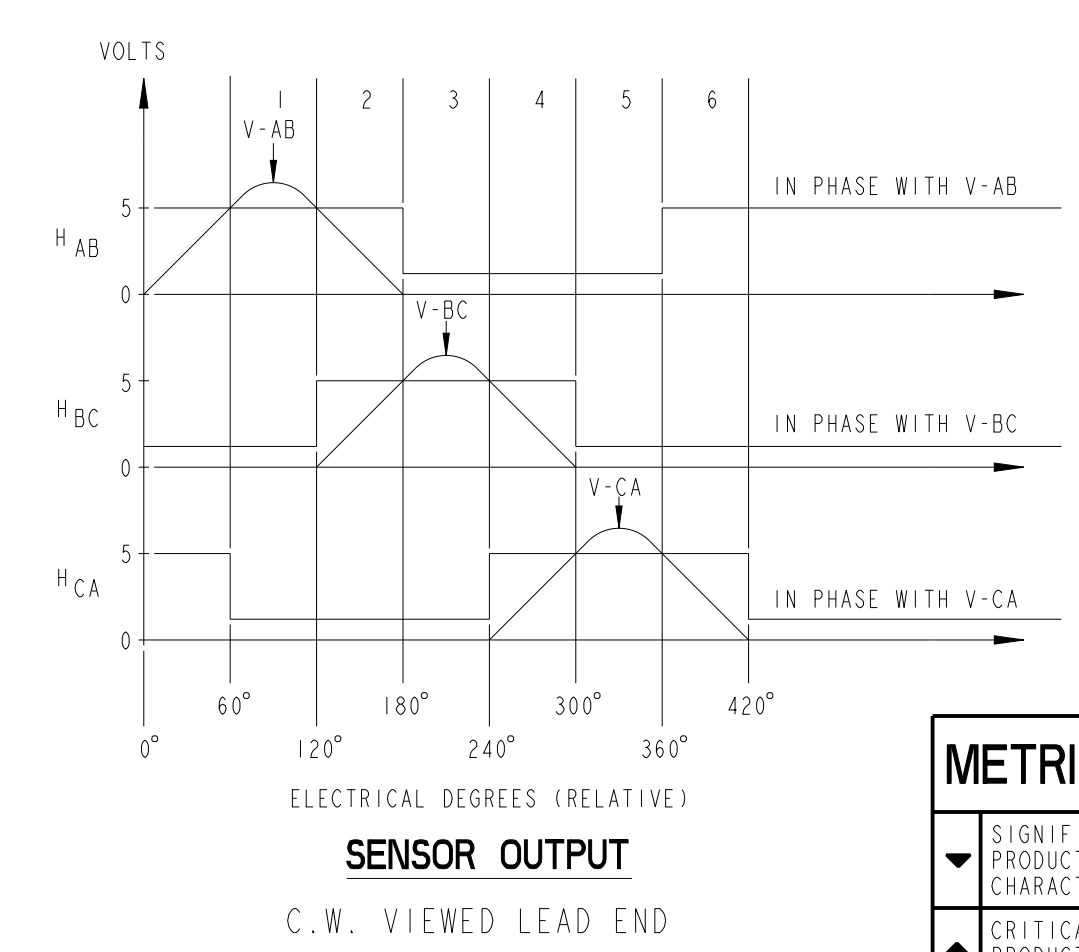
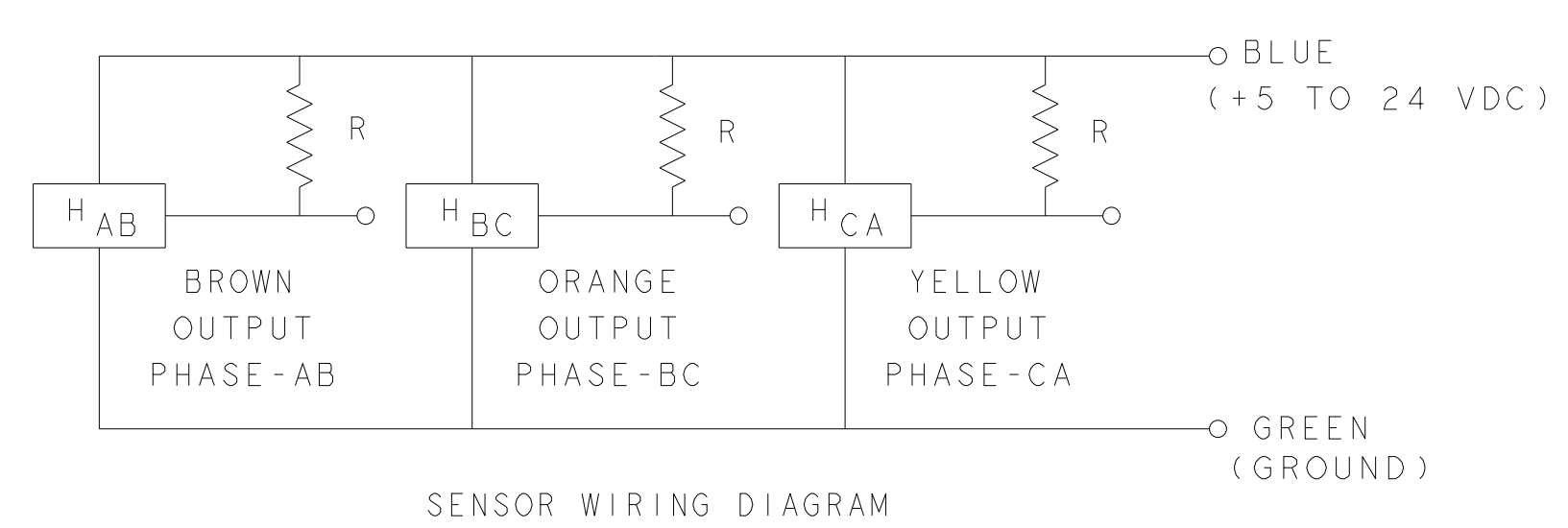

ATTENTION
 Static-Sensitive
 Devices
 Handle Only at
 Static-Safe
 Workstations

THIS DOCUMENT IS ONLY FOR USE BY THE INTENDED RECIPIENT AND CONTAINS KOLLMORGEN CONFIDENTIAL INFORMATION

Pro/E Instance Name: TBMS-76X-961006
 Pro/E Drawing Name: 961006
 Pro/E Model Type: ASSEM
 Pro/Engineer Drawing

METRIC DRAWING

SIGNIFICANT PRODUCT CHARACTERISTIC
 CRITICAL PRODUCT CHARACTERISTIC

ITEM	QTY	IDENTIFYING NO.	DESCRIPTION
3	AR	1M-2709	MARKING PROCEDURE
2	1	SEE TABLE	FIELD ASSEMBLY
1	1	SEE TABLE	ARMATURE AND SENSOR ASSEMBLY

LIST OF PARTS

UNLESS OTHERWISE SPECIFIED: REMOVE ALL SHARP BURRS AND BREAK ALL SHARP EDGES X DECIMAL PLACES ±.4 [0.015] XX DECIMAL PLACES ±.13 [0.005] ANGULAR DIMENSIONS ±1°		KOLLMORGEN	
DO NOT SCALE DRAWING; USE DIMENSIONS ONLY ALL DIMENSIONS ARE IN MILLIMETERS DIMENSIONS IN BRACKETS [] ARE IN INCHES AND ARE FOR REFERENCE ONLY INTERPRET GEOMETRIC SYMBOLS PER ANSI Y14.5M-1982		DATE: 22-Jan-14 DRAWN BY: M.STONE CHECKED BY: A.GARLICH	501 MAIN STREET RADFORD, VIRGINIA 24141
FSCM 11384	SIZE D	DWG. NO. 961006	REV A
SCALE: 2:1	JOB NO.:	SHEET 1 OF 1	