
Danaher Motion

Standalone MMC™

Hardware Manual
Version 16.0



Keep all product manuals as a product component during the life span of the product.
Pass all product manuals to future users/owners of the product.

Catalog No. M.1300.7620
Part No. M.3000.0673



Record of Revisions

Edition	Valid for	Description
03/2007	PiCPro V16.1	Added MMC-S16 Sercos Plus Module
09/2008	PiCPro V17.0	Added MMC-DSAXX Control
01/2009	PiCPro V17.0	Rev 1 added CE/UL info to MMC-DSAXX

Third party brands and trademarks are the property of their respective owners

Technical changes to improve the performance of the equipment may be made without notice!

Printed in USA

All rights reserved. No part of this work may be reproduced in any form (by printing, photocopying, microfilm or any other method) or processed, copied or distributed by electronic means without the written permission of Danaher Motion.

NOTE

These products are being manufactured and sold by G & L Motion Control, Inc., a Danaher Motion company ("Danaher Motion").

Progress is an on-going commitment at Danaher Motion. We continually strive to offer the most advanced products in the industry; therefore, information in this document is subject to change without notice. The text and illustrations are not binding in detail. Danaher Motion shall not be liable for any technical or editorial omissions occurring in this document, nor for any consequential or incidental damages resulting from the use of this document.

Danaher Motion makes every attempt to ensure accuracy and reliability of the specifications in this publication. Specifications are subject to change without notice. Danaher Motion provides this information "AS IS" and disclaims all warranties, express or implied, including, but not limited to, implied warranties of merchantability and fitness for a particular purpose. It is the responsibility of the product user to determine the suitability of this product for a specific application.

DO NOT ATTEMPT to use any Danaher Motion product until the use of such product is completely understood. It is the responsibility of the user to make certain proper operation practices are understood. Danaher Motion products should be used only by qualified personnel and for the express purpose for which said products were designed.

Should information not covered in this document be required, contact the Customer Service Department, Danaher Motion, 672 South Military Road, P.O. Box 1960, Fond du Lac, WI 54936-1960. Danaher Motion can be reached by telephone at (920) 921-7100 or (800) 558-4808 in the United States or by e-mail at glmotion.support@danahermotion.com.

Catalog No. (Order No.) M.1300.7620

Printed Version Part No. M.3000.0673

Electronic Version Part No. M.3000.0672 Rev 1

Release 01162009

©2009, Danaher Motion

Table of Contents

- 1 Introduction to the Standalone MMC 9**
 - 1.1 Overview..... 9
 - 1.2 Contents of This Manual..... 9
 - 1.3 Software and Manuals..... 9
 - 1.3.1 Required Software and Manuals..... 9
 - 1.3.2 Suggested Manuals 10
 - 1.4 Danaher Motion Support Contact 10

- 2 Safety Precautions..... 11**
 - 2.1 System Safety 11
 - 2.1.1 User Responsibility 11
 - 2.1.2 Safety Instructions..... 11
 - 2.2 Safety Signs 12
 - 2.3 Warning Labels..... 12
 - 2.4 Safety First 13
 - 2.5 Safety Inspection 13
 - 2.5.1 Before Starting System 13
 - 2.6 After Shutdown 13
 - 2.7 Operating Safely..... 14
 - 2.8 Electrical Service & Maintenance Safety 14
 - 2.9 Safe Cleaning Practices 15

- 3 Installation, Operation, & Maintenance..... 17**
 - 3.1 Mounting the MMC Control..... 17
 - 3.2 Adding an Option Module to the MMC Control..... 18
 - 3.3 Dimensions and Mounting of MMC with Option Modules Attached..... 20
 - 3.4 System Power and Environment Requirements..... 21
 - 3.4.1 General Power and Environment Requirements..... 21
 - 3.4.2 Control Cabinet Specifications..... 22
 - 3.4.3 Power Distribution Diagram 22
 - 3.4.4 Grounding the System 23
 - 3.4.5 Controlling Heat Within the System 24
 - 3.4.6 Handling an MMC Control..... 25
 - 3.5 System Wiring Guidelines 26
 - 3.5.1 Recommended Signal Separation 26
 - 3.5.2 Differential Devices for Analog and Encoder Signals..... 27
 - 3.6 Starting an Application..... 28
 - 3.7 Basic Setup and Maintenance Procedures 28
 - 3.7.1 Battery Replacement..... 29
 - 3.8 System Status Lights..... 31
 - 3.8.1 Power Status..... 31
 - 3.8.2 Battery Status..... 31
 - 3.8.3 Scan Status..... 31
 - 3.8.4 Power-up Diagnostics Status..... 31
 - 3.8.5 Run-time Diagnostic Status..... 32
 - 3.8.6 Diagnostic Error Codes..... 32

- 4 Standalone MMC Control 35**
 - 4.1 Introduction..... 35
 - 4.2 Features 35
 - 4.3 Overview..... 35

4.3.1 Machine Control Board.....	38
4.3.2 Motion Control Board.....	38
4.3.2.1 Analog Servo board	38
4.3.2.2 SERCOS board.....	39
4.4 Power Supply Requirements.....	39
4.5 Machine Control Connectors & Operation	43
4.5.1 PiCPro Port.....	43
4.5.2 Block I/O Port	45
4.5.3 User Port	49
4.5.4 General I/O Port	55
4.5.4.1 DC Output Operation	59
4.5.4.2 DC Input Operation	62
4.5.5 Power Connection	64
4.6 Analog Motion Control Connectors & Operation	64
4.6.1 Axis I/O Ports.....	64
4.6.1.1 Axis I/O Port DC Outputs	69
4.6.1.2 Axis I/O Port DC Input.....	71
4.6.1.3 Axis I/O Port Analog Output	72
4.6.1.4 Axis I/O Port Encoder Input.....	73
4.6.2 Aux I/O Port	74
4.6.2.1 Isolated Breakout Box Details	79
4.6.2.2 Aux I/O Port Fast Inputs	81
4.6.2.3 Aux I/O Port DC Inputs.....	83
4.6.2.4 Aux I/O Port Encoder Input	84
4.6.2.5 Aux I/O Port Analog Input	85
4.7 SERCOS Motion Control Connections & Operation	85
4.7.1 SERCOS Receive and Transmit Ports	85
4.7.2 Loader Port.....	87
4.8 Specifications	90
5 Standalone Digital MMC Control.....	95
5.1 Introduction	95
5.2 Features	95
5.3 Overview	95
5.4 Power Supply Requirements.....	96
5.5 Connectors & Operation.....	97
5.5.1 Block I/O Port	98
5.5.2 User Port	102
5.5.3 PiCPro Port.....	108
5.5.4 Ethernet Port	110
5.5.5 Digital Link Ports.....	112
5.5.6 User USB Port	114
5.5.7 PiCPro USB Port	114
5.5.8 Power Connection	114
5.6 Specifications	116
6 MMC-DSAXX Control.....	119
6.1 Introduction	119
6.2 Features	119
6.3 Overview	119
6.3.1 Major Components	120
6.4 Power Supply Requirements.....	122
6.5 Connectors & Operation.....	122
6.5.1 PiCPro Port.....	123

6.5.2 Ethernet Port	124
6.5.3 Block I/O Port (C1)	126
6.5.4 User Port	130
6.5.5 Digital Link Port	136
6.5.6 General I/O Port	138
6.5.6.1 DC Output Operation	143
6.5.6.2 DC Input Operation	145
6.5.7 Power Connection	147
6.6 Specifications	148
7 MMC Ethernet TCP/IP Option Module	151
7.1 Introduction	151
7.2 Connections	151
7.2.1 The Ethernet Port	153
7.2.2 The RS232 COMM Ports	155
7.3 LEDs	157
7.4 Firmware Update	158
7.5 Theory of operation	158
7.6 Specifications Table	160
7.7 Useful Internet Links	161
8 MMC DeviceNet[™] Option Module	163
8.1 Introduction	163
8.2 Connections	164
8.2.1 The DeviceNet Port	165
8.2.2 The Configuration (RS232) Port	165
8.3 LEDs	166
8.4 Theory of Operation	166
8.5 Specifications	168
9 MMC Profibus Option Module	169
9.1 Introduction	169
9.2 Connections	170
9.2.1 The Profibus Port	171
9.2.2 The Configuration (RS232) Port	171
9.3 LEDs	172
9.4 Theory of Operation	172
9.5 Specifications for Profibus Module	174
10 MMC Axis I/O Option Module	175
10.1 Specifications	177
11 MMC 32In/32Out Option Module	181
11.1 Introduction	181
11.2 Connections & Operation	182
11.2.1 DC Output Operation	186
11.2.2 DC Input Operation	189
11.3 Specifications	191
12 CE and EMC Guidelines	193
12.1 Background on EMC (Electromagnetic Compatibility) Compliance	193
12.2 Background on Low Voltage Compliance	193
12.3 RFI Emission and Immunity	193
12.4 Classes of EMC Operating Environments	194

- 12.5 Conformance with the EMC Directive 195
- 12.6 Conformance With the Low Voltage Directive..... 195
- 12.7 Changes to the PiC Products..... 195
 - 12.7.1 Changes Affecting the User..... 195
- 12.8 Using CE/EMC and Non-CE/EMC Modules 198
- 12.9 Declarations of Conformity 200

- Appendix A - Operation Details..... 205**
 - A.1 Introduction 205
 - A.2 DC Inputs..... 205
 - A.3 DC Outputs 206
 - A.3.1 Inductive Loads 206
 - A.4 Encoder Inputs..... 207

- Index 209**

- Sales and Service 214**

1 Introduction to the Standalone MMC

1.1 Overview

The Standalone Machine and Motion Control (MMC) product line consists of four distinct products:

- The Standalone MMC Control, which is available in two configurations to control:
 - Analog Interfaced drives (such as the Analog Interfaced MMC-SD) via a $\pm 10V$ analog output.
 - SERCOS Interfaced drives.
- The Standalone Digital MMC Control, which controls up to 64 Digital Interfaced drives (Digital MMC-SD Drives and S200-DSL Drives) via a digital connection (Digital Link).
- The Standalone MMC-DSAXX Control, which controls up to 16 Digital Interfaced drives (Digital MMC-SD Drives and S200-DSL Drives) via a digital connection (Digital Link).
- MMC Option Modules, which provide various added functionality to the Standalone MMC Control, the Standalone Digital MMC Control, and the Standalone MMC-DSAXX Control.

Unless otherwise noted, all of the information in this manual applies to all of the MMC Controls described above.

1.2 Contents of This Manual

This manual includes the following major topics:

- Information to safely operate and maintain the equipment in a safe manner.
- User responsibilities for product acceptance and storage.
- Power and environmental information for general power, control cabinet, grounding, heat control and handling.
- Procedures for mounting, wiring, and connecting the MMC Control.
- The function, location, and signal descriptions of connectors on the MMC Control.
- Physical, electrical, environmental and functional specifications/dimensions.
- Description of the minimal maintenance necessary.
- A troubleshooting chart of potential problems and possible solutions.
- Part numbers and descriptions for the MMC Control, MMC Option Modules, and related equipment.

1.3 Software and Manuals

1.3.1 Required Software and Manuals

- PiCPro (one of the following):
 - Professional Edition
 - MMC Limited Edition
 - Monitor Edition

1.3.2 **Suggested Manuals**

- Function/Function Block Reference Guide
- Motion Application Specific Function Block Manual
- Ethernet Application Specific Function Block Manual
- General Purpose Application Specific Function Block Manual

1.4 **Danaher Motion Support Contact**

Contact your local Danaher Motion representative for:

- Sales and order support
- Product technical training
- Warranty support
- Support service agreements

Danaher Motion Technical Support can be reached:

- In the United States, telephone (800) 558-4808
- Outside the United States, telephone (920) 921-7100
- E-mail address: glmotion.support@danahermotion.com
- Web site: www.glcontrols.com

2 Safety Precautions

READ AND UNDERSTAND THIS SECTION IN ITS ENTIRETY BEFORE UNDERTAKING INSTALLATION OR ADJUSTMENT OF THE MMC SMART DRIVE AND ANY ASSOCIATED SYSTEMS OR EQUIPMENT

The instructions contained in this section will help users to operate and maintain the equipment in a safe manner.

PLEASE REMEMBER THAT SAFETY IS EVERYONE'S RESPONSIBILITY

2.1 System Safety


The basic rules of safety set forth in this section are intended as a guide for the safe operation of equipment. This general safety information, along with explicit service, maintenance and operational materials, make up the complete instruction set. All personnel who operate, service or are involved with this equipment in any way should become totally familiar with this information prior to operating.

2.1.1 User Responsibility

It is the responsibility of the user to ensure that the procedures set forth here are followed and, should any major deviation or change in use from the original specifications be required, appropriate procedures should be established for the continued safe operation of the system. It is strongly recommended that you contact your OEM to ensure that the system can be safely converted for its new use and continue to operate in a safe manner.

2.1.2 Safety Instructions

- Do not operate your equipment with safety devices bypassed or covers removed.
- Only qualified personnel should operate the equipment.
- Never perform service or maintenance while automatic control sequences are in operation.
- To avoid shock or serious injury, only qualified personnel should perform maintenance on the system.

ATTENTION	
	Do not touch the main power supply fuses or any components internal to the power modules while the main power supply switch is ON. Note that when the main power switch is OFF, the incoming supply cable may be live.

- **GROUNDING (Protective Earth)**

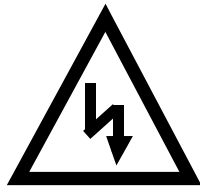
The equipment must be grounded (connected to the protective earth connection) according to OEM recommendations and to the latest local regulations for electrical safety. The grounding (protective earth) conductor must not be interrupted inside or outside the equipment enclosures. The wire used for equipment grounding (connection to protective earth) should be green with a yellow stripe.

2.2 Safety Signs

The purpose of a system of safety signs is to draw attention to objects and situations which could affect personal or plant safety. It should be noted that the use of safety signs does not replace the need for appropriate accident prevention measures. Always read and follow the instructions based upon the level of hazard or potential danger.

2.3 Warning Labels

Hazard warning



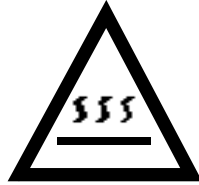
Danger Electric
Shock Risk

When you see this safety sign on a system, it gives a warning of a hazard or possibility of a hazard existing. The type of warning is given by the pictorial representation on the sign plus text if used.

To ignore such a caution could lead to severe injury or death arising from an unsafe practice.

Danger, Warning, or Caution warning

Symbol plus DANGER, WARNING or CAUTION:
These notices provide information intended to prevent potential personal injury and equipment damage.

Hot Surface warning

Symbol plus HOT SURFACE:
These notices provide information intended to prevent potential personal injury.

2.4 Safety First

Danaher Motion equipment is designed and manufactured with consideration and care to generally accepted safety standards. However, the proper and safe performance of the equipment depends upon the use of sound and prudent operating, maintenance and servicing procedures by trained personnel under adequate supervision.

For your protection, and the protection of others, learn and always follow these safety rules. Observe warnings on machines and act accordingly. Form safe working habits by reading the rules and abiding by them. Keep these safety rules handy and review them from time to time to refresh your understanding of them.

2.5 Safety Inspection**2.5.1 Before Starting System**

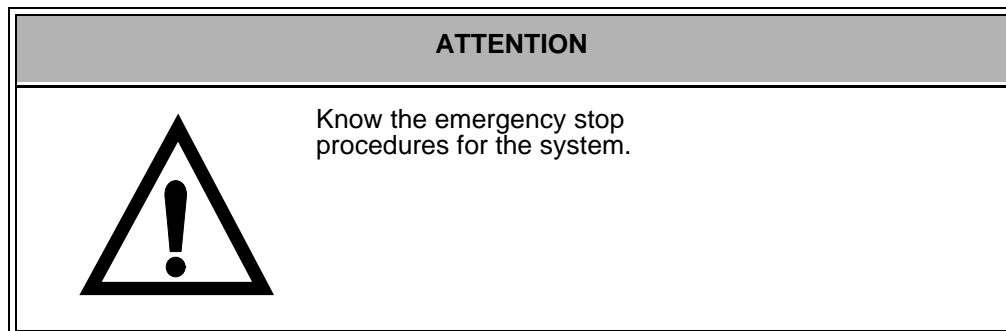
- Ensure that all guards and safety devices are installed and operative and all doors which carry warning labels are closed and locked.
- Ensure that all personnel are clear of those areas indicated as potentially hazardous.
- Remove (from the operating zone) any materials, tools or other objects that could cause injury to personnel or damage the system.
- Make sure that the control system is in an operational condition.
- Make certain that all indicating lights, horns, pressure gauges or other safety devices or indicators are in working order.

2.6 After Shutdown

Make certain all controlled equipment in the plant is safe and the associated electrical, pneumatic or hydraulic power is turned off. It is permissible for the control equipment contained in enclosures to remain energized provided this does not conflict with the safety instructions found in this section.

2.7 Operating Safely

- Do not operate the control system until you read and understand the operating instructions and become thoroughly familiar with the system and the controls.
- Never operate the control system while a safety device or guard is removed or disconnected
- Where access to the control system is permitted for manual operation, only those doors which provide that access should be unlocked. They should be locked immediately after the particular operation is completed.
- Never remove warnings that are displayed on the equipment. Torn or worn labels should be replaced.
- Do not start the control system until all personnel in the area have been warned.
- Never sit or stand on anything that might cause you to fall onto the control equipment or its peripheral equipment.
- Horseplay around the control system and its associated equipment is dangerous and should be prohibited.




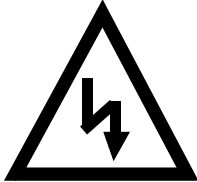
- Never operate the equipment outside specification limits.
- Keep alert and observe indicator lights, system messages and warnings that are displayed on the system.
- Do not operate faulty or damaged equipment. Make certain proper service and maintenance procedures have been performed.

2.8 Electrical Service & Maintenance Safety

- **ALL ELECTRICAL OR ELECTRONIC MAINTENANCE AND SERVICE SHOULD BE PERFORMED BY TRAINED AND AUTHORIZED PERSONNEL ONLY.**
- It should be assumed at all times that the POWER is ON and all conditions treated as live. This practice assures a cautious approach which may prevent accident or injury.
- To remove power:
LOCK THE SUPPLY CIRCUIT DISCONNECTING MEANS IN THE OPEN POSITION.
APPLY LOCKOUT/TAGOUT DEVICES IN ACCORDANCE WITH A DOCUMENTED AND ESTABLISHED POLICY.

- Make sure the circuit is safe by using the proper test equipment. Check test equipment regularly.

ATTENTION	
	Care should be taken if you are manually discharging the bus capacitors.

WARNING	
	Even after power to the drive is removed, it may take up to 10 minutes for bus capacitors to discharge to a level below 50 VDC. To be sure the capacitors are discharged, measure the voltage across the + and - terminals for the DC bus.

- There may be circumstances where troubleshooting on live equipment is required. Under such conditions, special precautions must be taken:
 - Make sure your tools and body are clear of the areas of equipment which may be live.
 - Extra safety measures should be taken in damp areas.
 - Be alert and avoid any outside distractions.
 - Make certain another qualified person is in attendance.
- Before applying power to any equipment, make certain that all personnel are clear of associated equipment.
- Control panel doors should be unlocked only when checking out electrical equipment or wiring. On completion, close and lock panel doors.
- All covers on junction panels should be fastened closed before leaving any job.
- Never operate any controls while others are performing maintenance on the system.
- Do not bypass a safety device.
- Always use the proper tool for the job.
- Replace the main supply fuses only when electrical power is OFF (locked out).

2.9 Safe Cleaning Practices

- Do not use toxic or flammable solvents to clean control system hardware.
- Turn off electrical power (lock out) before cleaning control system assemblies.
- Keep electrical panel covers closed and power off when cleaning an enclosure.

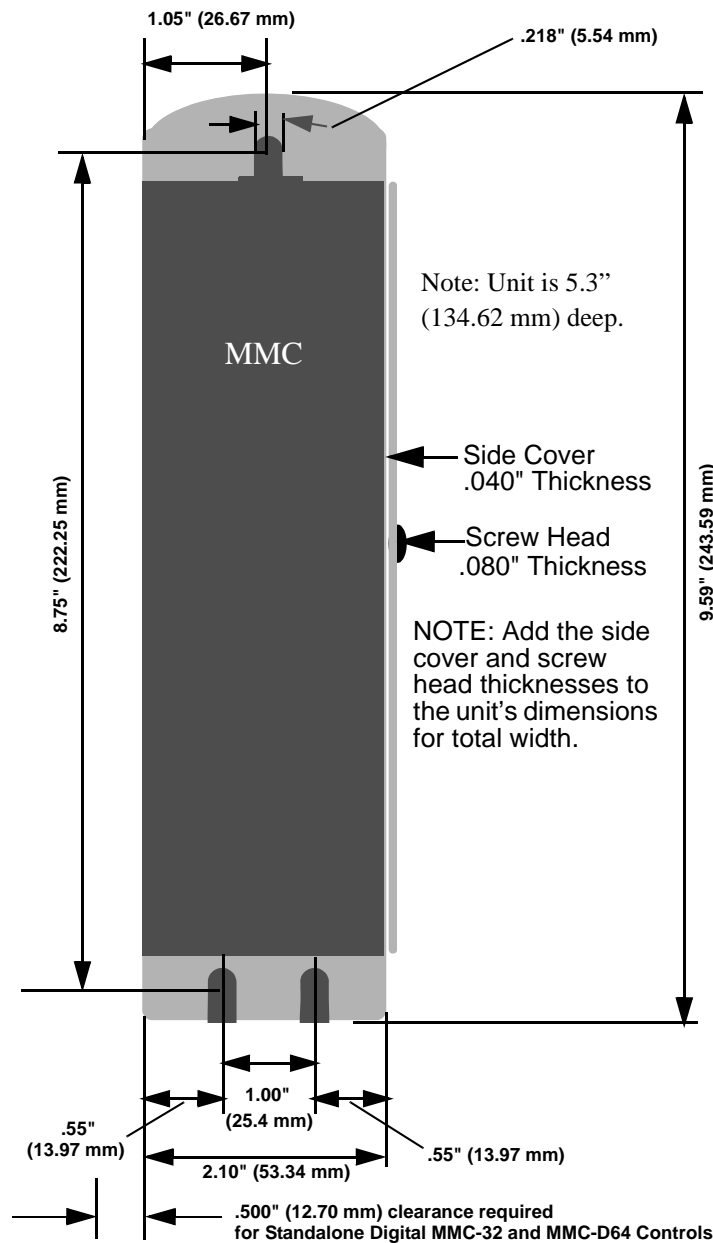
- Always clean up spills around the equipment immediately after they occur.
- Never attempt to clean a control system while it is operating.
- Never use water to clean control equipment unless you are certain that the equipment has been certified as sealed against water ingress. Water is a very good conductor of electricity and the single largest cause of death by electrocution.

3 Installation, Operation, & Maintenance

3.1 Mounting the MMC Control

Mount the unit to your cabinet using the mounting slots on the MMC as shown. (Note: the Standalone MMC-D32 and MMC-D64 Digital Controls requires a minimum of 1/2 in clearance on the left side, for proper fan air movement). The MMC unit must be mounted vertically. The recommended size of mounting hardware is #10 bolts with #10 star washers (to ensure proper ground connection) as shown in [Figure 3-1](#) below.

Figure 3-1: MMC Mounting Dimensions



3.2 Adding an Option Module to the MMC Control

Several Option Modules are available to add functionality to the MMC system. These modules are described in the later sections of this manual, starting with [section 7 on page 151](#).

- The standard Standalone MMC Control (MMC-A2, MMC-A4, and MMC-S8) accepts up to two MMC Option Modules.

- The Standalone MMC Control Plus (MMC-A2 Plus and MMC-A4 Plus), the Standalone MMC-DSAXX Control (MMC-DSA2, -DSA4, -DSA8, and -DSA16), and the Standalone Digital MMC Control (MMC-D32 and MMC-D64), accepts up to four MMC Option Modules.

Option modules are shipped with a 50-pin square post connector and screws needed to attach the module to the MMC (or to another option module). Follow the procedure below to add an option module to the MMC (or to another option module).

1. Place the MMC and the option module on a static free surface. Ground yourself using a properly grounded wrist strap before you begin. These are standard precautions before handling any electronic components.
2. Remove the five screws securing the MMC cover using a #1 Phillips screwdriver and set them aside. There are two screws on the top, two screws on the bottom, and one screw on the side of the module. Lift the side cover off and set aside.
3. Locate the 50-pin square post socket at the top of the MMC board. Press one side of the 50-pin square post male connector into this socket ensuring that the pins are aligned and it is firmly seated.
4. Pick up the option module. Line up the socket on the option module with the male end of the connector extending from the MMC ensuring that the pins are aligned. Press firmly into place. Be sure to align the screw tabs on the top and bottom of the option module with the screw slots on the top and bottom of the MMC module so that the modules slide together easily.
5. Screw four screws (of the five included in your package) into the screw tabs to attach the option module to the MMC.
6. Lay the unit on the bench. Place the cover you set aside in Step 3 on the option module. Be sure to align the screw tabs on the top and bottom of the cover with the screw slots on the top and bottom of the option module.
7. Screw the five screws removed in Step 2 back into place to secure the cover.

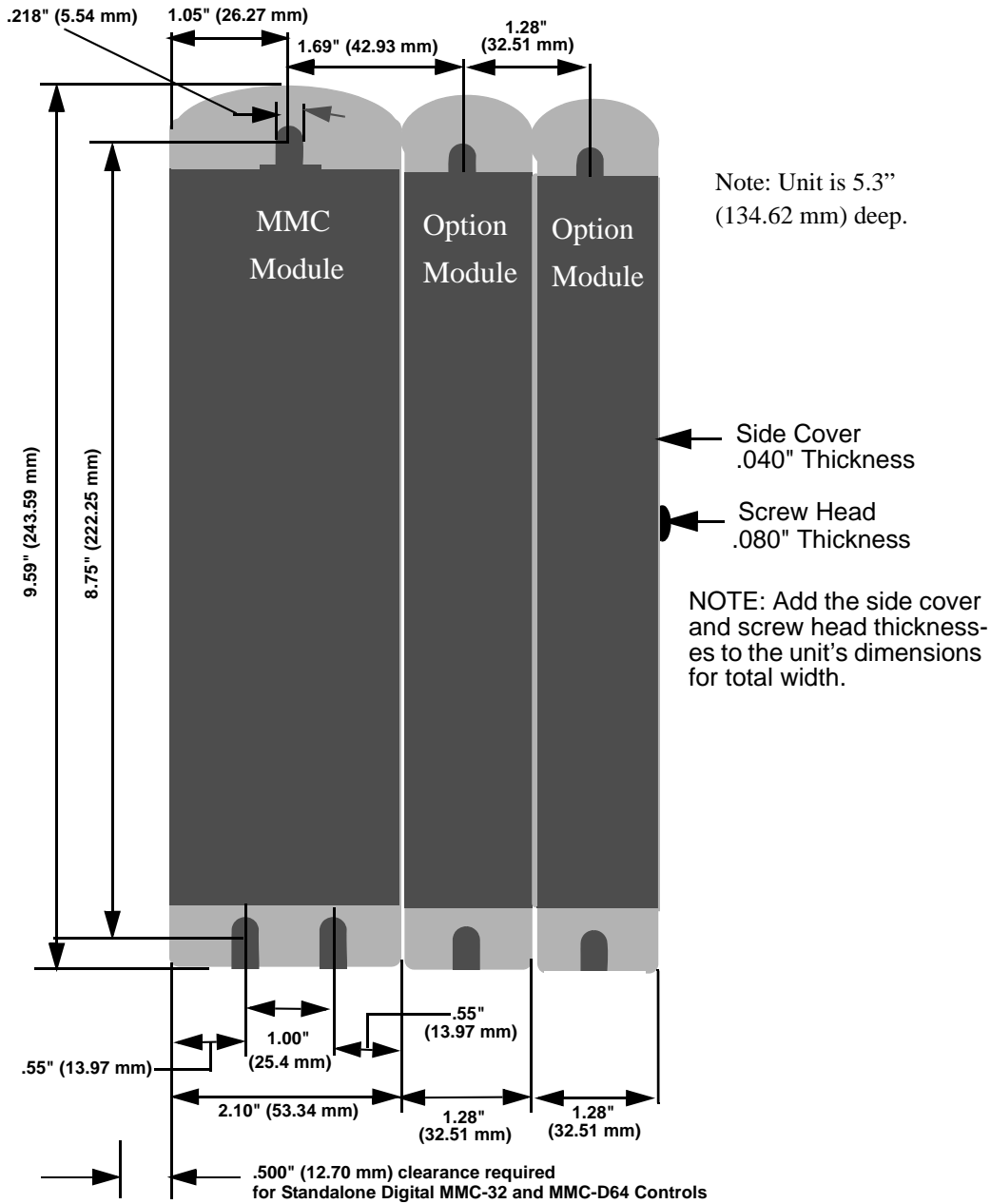
Figure 3-2: Location of Screws on the MMC Control (MMC A-4 Servo Unit Shown)



3.3 Dimensions and Mounting of MMC with Option Modules Attached

After attaching option modules to the MMC module, mount the unit to your cabinet using the mounting slots on the MMC and the option module. The recommended size of mounting hardware is #10 bolts with #10 star washers (to ensure proper ground connection).

Figure 3-3: MMC Mounting Dimensions with 2 Option Modules Attached



3.4 System Power and Environment Requirements

3.4.1 General Power and Environment Requirements

The MMC is suitable for operation in a pollution degree 2 environment (i.e., normally, only non-conductive pollution occurs). You are not required to install the system rack

in a control cabinet. However a cabinet protects the system from dust and mechanical damage and is recommended.

Power distribution is shown in [Figure 3-4 on page 23](#). Install the system rack away from all sources of strong electromagnetic noise. Such noise can interfere with MMC operation.

Protect the MMC system from all the following:

- conductive fluids and particles
- corrosive atmosphere
- explosive atmosphere

The diagrams and recommendations may be modified if necessary so the wiring conforms to current NEC standards or government regulations.

3.4.2 Control Cabinet Specifications

The control cabinet housing the MMC:

- should have a NEMA-12 rating or better. A cabinet with this rating protects its contents from dust and mechanical damage.
- must be large enough to provide adequate air circulation for the MMC, drives, and other components. Always allow for adequate air flow through the MMC vents.
- must have a rigid vertical surface to mount the MMC on.
- should be positioned to allow the cabinet door to open fully for easy access to the MMC Control.

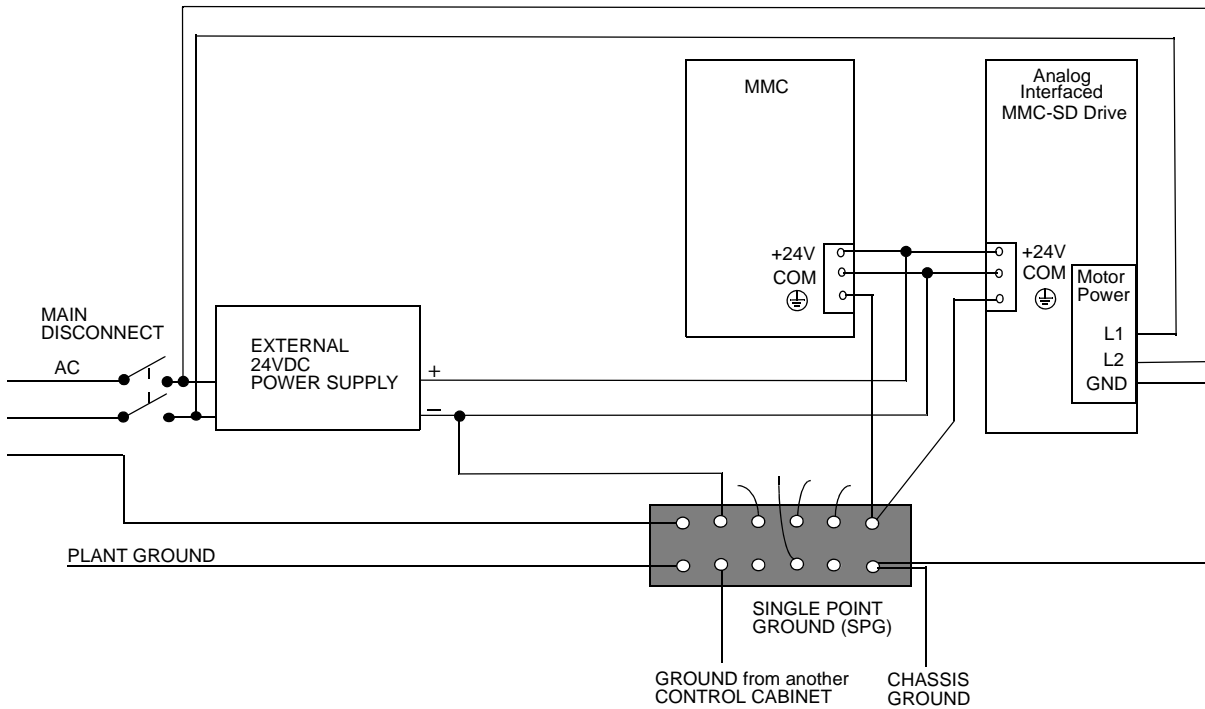
IMPORTANT

Post warnings according to National, State, or local codes for the voltage present in the control cabinet.

3.4.3 Power Distribution Diagram

The MMC requires an external DC power source. The power distribution drawing that follows shows an MMC connected to an Analog Interfaced MMC-SD Drive. The drive's 24 VDC power is supplied via the MMC in this example. If the drive has its own external 24 VDC supply, the +24 V line would not be connected.

Figure 3-4: Example of 24 VDC Power Distribution to an MMC System



The DC power source is connected to the MMC system through a 3-pin connector. It plugs into the power connector of the MMC. The ground from the power source and ground from the MMC must be connected to the Single-Point Ground (SPG).

Devices connected to the hardware may have their own power sources for input data or output control signals. You can use other wiring setups, provided that each one is:

- at the correct voltage and current levels for the module and the device.
- connected to the same Single-Point Ground that the MMC uses.

It is recommended that the same main disconnect switch be used for the MMC system and for all devices in the application.

IMPORTANT

No matter how the system is installed, before you connect the MMC to the application, make sure that power is off to the system and to the devices that are wired to the MMC.

3.4.4 Grounding the System

The ground of the MMC power source must be connected directly to a *Single Point Ground (SPG)* tie block. The tie block should be made of brass or copper, bolted or brazed to the control cabinet. If the tie block is bolted rather than brazed, scrape away paint or grease at the point of contact. Put star washers between the tie block and the cabinet to ensure good electrical contact.

Metal enclosures of power supplies, drives, etc., should also have good electrical contact with the SPG.

CAUTION

The Single Point Ground should be the only common point for all the ground lines. If not, ground loops may cause current flow among components of the system which can interfere with proper operation of the MMC.

Devices to be connected directly to the Single Point Ground include:

- Plant safety ground.
- Chassis ground from MMC power connector.
- The metal panel or cabinet on which the MMC is mounted.
- “Common” or “0 V” lines from power supplies that provide external power to the I/O modules and the devices to which they are connected.
- Chassis grounds from the devices themselves, such as device drivers, machinery, and operator interface devices.
- AC common line from the noise filter, if any.
- The ground of the power source of the computer workstation, if any, from which you monitor the system operation. An AC outlet in the control cabinet is recommended.
- Single point grounds from other control cabinets, if any, in the system.

IMPORTANT

You must ensure that the “0V” or “Common” of all devices connected to the MMC are connected to Single Point Ground (SPG). Failure to do so may result in erratic operation or damage to the MMC. Examples of devices connected to the MMC include the power source that supplies 24VDC power to the MMC and devices connected to the MMC PiCPro Port or User Port. Note that some devices (for example, a Personal Computer) may have their “0V” and “Chassis” connected together internally, in which case only one connection has to be made to SPG for that device.

Also, you must ensure that the MMC “Chassis” connection is connected to SPG, and that the MMC is mounted to a metal panel or enclosure that is connected to SPG.

3.4.5 Controlling Heat Within the System

The MMC hardware case is designed to promote air circulation and dissipate heat. The MMC must be mounted vertically to take advantage of this design. Normally no fans or air conditioners are needed. However, if the environment outside the control cabinet is hot or humid, you may need to use a fan, heat exchanger, dehumidifier or air conditioner to provide the correct operating environment.

Temperature	5 to 55° C (41 to 131° F)
Relative humidity	5 to 95%, non-condensing

Make sure that components installed in the cabinet with the MMC do not raise the temperature above system limits and that any hot spots do not exceed specifications. For example, when heat-generating components such as transformers, drives or motor controls are installed, separate them from the system by doing one of the following:

- Place them near the top of the control cabinet so their heat output rises away from the MMC.
- Put them in another control cabinet above or to one side of the cabinet with the MMC. This protects the MMC from both heat and electrical noise.

The MMC itself is a source of heat, though in most installations its heat dissipates without harmful effects. System heat is generated from power dissipated by:

- field side input/output components
- other components within the MMC

CAUTION
If the MMC is operated outside the recommended limits, it may be damaged. This will void the warranty.

3.4.6 Handling an MMC Control

The case protects the MMC's internal circuitry against mechanical damage in shipping and handling. However, like any electronics device, the circuitry can be destroyed by:

- temperatures over 55° C (131° F)
- moisture condensing inside the module
- static discharge
- exposure to a magnetic field strong enough to induce a current in the circuitry
- freezing temperatures, vibration, and other hazards

Normally there is no need to open the case. Occasionally, a battery must be replaced. A diagram and detailed anti-static precautions in the appendices are included with modules that have replaceable components.

3.5 System Wiring Guidelines

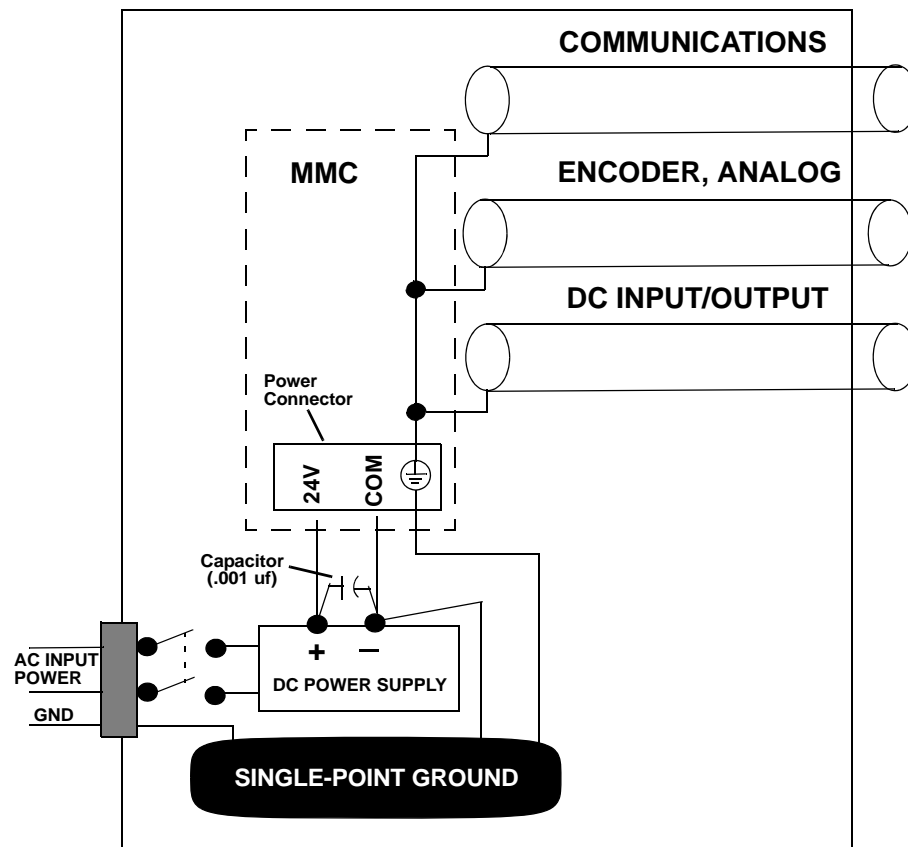
The MMC relies on electrical signals to report what is going on in the application and to send commands to it. In addition, signals are constantly being exchanged within the system. The MMC is designed for use in industrial environments, but some guidelines should be followed.

3.5.1 Recommended Signal Separation

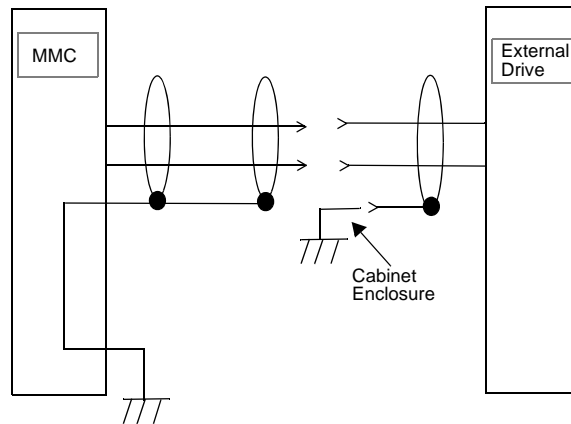
Danaher Motion continues to recommend separation of low level signals (encoder, analog, communications, fast DC inputs) from high voltage (110 Vac, 220 Vac, 440 Vac, etc.) or high current lines (such as motor armature cables). Maintain at least one inch of separation around signals.

[Figure 3-5](#) below illustrates the recommended connections when using EMC compliant products. Note that a capacitor is connected to the 24 VDC supply. To prevent excessive conducted emissions from a DC power source (typically 24 V) used for digital I/O, a 1000 picofarad capacitor should be used. Connect the capacitor from the +24 VDC to COMMON at the distribution terminals.

Figure 3-5: Recommended EMC Compliant Connections



Inside a control cabinet, connect the shields of shielded cables at the MMC. [Figure 3-6](#) below illustrates shielded cable entering/leaving the cabinet.

Figure 3-6: Connecting Shielded Cable

The two different methods of terminating shields are used to accommodate two different immunity requirements. Immunity required inside an enclosure is considered lower because cables are typically less than three meters in length and/or can be separated from each other and from noise sources.

Immunity required external to an enclosure is considered higher because the user may have less control over the noise environment. Low level signal cables that can be external to an enclosure are tested at a 2 KV level for electrical fast transients (EFTs). Low level signals that can be less than three meters in length or can be separated from noise sources are tested at a 1 KV level. Under the stated conditions, there will be no disturbance of digital I/O, encoder, or encoder operation. For analog signals, there may be momentary disturbances but there will be self-recovery when the noise subsides.

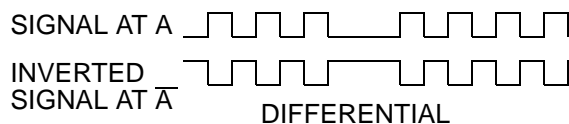
Do not operate transmitters, arc welding equipment, or other high noise radiators within one meter of an enclosure that has the door open. Continue to equip inductive devices, if they are in series with a mechanical contact or switch, with arc suppression circuits. These devices include contactors, solenoids and motors. Shield all cables that carry heavy current near the system, using continuous foil wrap or conduit grounded at both ends. Such cables include power leads for high-frequency welders and for pulse-width-modulated motor drives.

WARNING

Use care when wiring I/O devices to the MMC and when plugging in cables. Wiring the wrong device to the connector or plugging a connector into the wrong location could cause intermittent or incorrect machine operation.

3.5.2 Differential Devices for Analog and Encoder Signals

A *differential* device receives or sends one signal over two wires (typically a shielded twisted pair). The input/output voltage at the second terminal is the inverse of the first. Information is received/sent as the difference between the two voltages.

Figure 3-7: Differential Digital Pulse Train

The advantages of using differential signals are:

- A differential signal is less susceptible to electromagnetic noise. Static or other interference affects both of the twisted-pair wires equally, so the difference between the normal and inverted voltage remains unchanged. A differential signal can be transmitted over a much longer distance or in a much noisier environment than a single-ended one.
- MMC hardware circuitry can detect signal loss from an encoder if the signal is differential. The application program can be set to shut down the application if such an error is detected.

IMPORTANT

Always use differential drivers with differential inputs.

3.6 Starting an Application

To start an application:

1. Turn off the main disconnect switch in the control cabinet. If some devices are not powered from the control cabinet, turn them off also.
2. Connect the connectors according to your diagrams.
3. Turn on power to the system. The MMC goes through the following sequence:
 - The Power light (labeled “P”) goes on and stays on.
 - The Diagnostic light (labeled “D”) goes on briefly, then goes off.
 - If there is an application in the MMC’s memory, the ladder starts scanning and the Scan light (labeled “S”) goes on. If there is not an application in the MMC’s memory, use the download command in the PICPro software to place it there.

3.7 Basic Setup and Maintenance Procedures

[Table](#) below summarizes how to proceed when performing certain maintenance and/or setup functions.

Table 3-2: Maintenance Procedure Summary	
In order to:	
Turn off the entire application.	Turn off main disconnect (which should also turn off all external power supplies to the application); unplug the DC power to the MMC.
Wire the I/O to the application.	Turn off main disconnect (which should also turn off all external power supplies to the application); unplug the DC power to the MMC.
Change the battery.	Turn off main disconnect (which should also turn off all external power supplies to the application); unplug the DC power to the MMC.
Connect/disconnect the MMC with the computer workstation through the PiCPro port.	Turn off main disconnect (which should also turn off all external power supplies to the application); unplug the DC power to the MMC.
Connect/disconnect the MMC with an operator interface through the User port.	Turn off main disconnect (which should also turn off all external power supplies to the application); unplug the DC power to the MMC.
Download an application program into the memory.	Make sure power is on (check the P light).
Stop the scan.	From the workstation - use the Stop Scan commands in the PiCPro software.

3.7.1 Battery Replacement

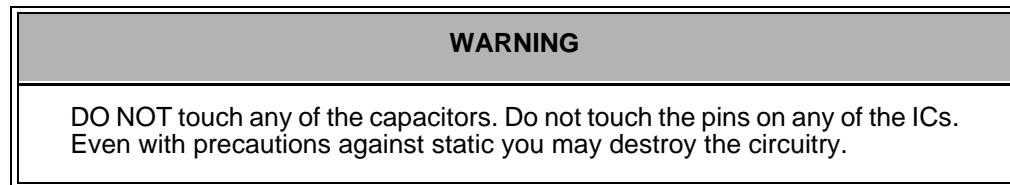
Replace the battery under the following conditions:

- as a preventative maintenance procedure (approximately every 5 years)
- when the MMC indicates that the battery is low:
 - On a Standalone MMC Control (-A2, -A4, -S8, -S16), if the green Power light (P) starts flashing.
 - On a Standalone Digital MMC Control (-D32, -D64) or MMC-DSAXX Control (-DSA2, DSA-4, -DSA8, -DSA16), when the Diagnostic Light flashes the "Replace Battery" code:

Follow the procedure below to replace the battery:

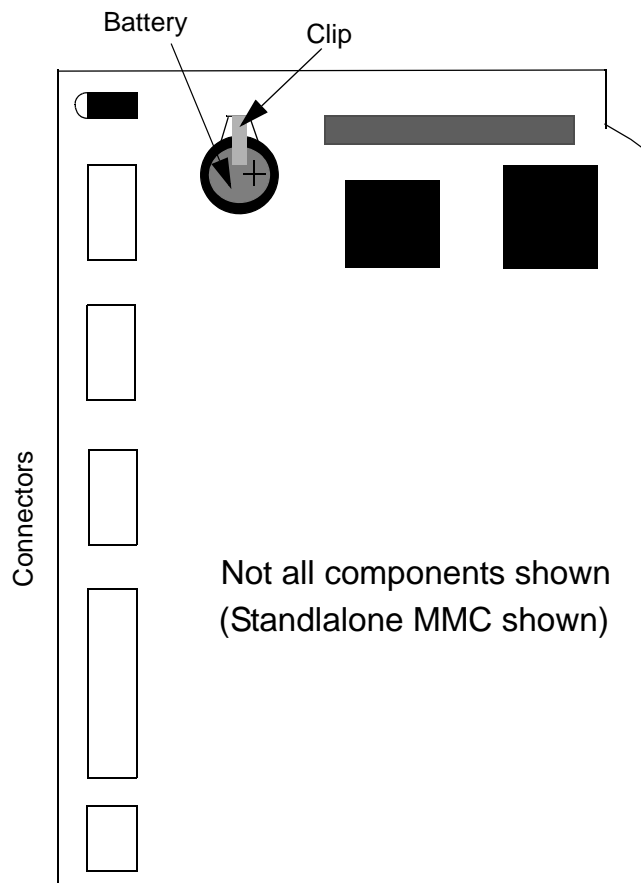
1. After DC power has been applied to the MMC for at least five minutes, turn off power. This ensures that the contents of memory will not be lost while the battery is removed. Disconnect the input power connector from the MMC.
2. Remove the MMC (including any optional modules) from the cabinet.
3. Use a static-free work surface if possible. Ground yourself using a properly grounded wrist strap before you open the case. These are standard precautions before handling any electronics component.
4. Lay the MMC system on the work surface. If there are no optional modules attached, remove the cover by removing the five screws, two on top, two on the bottom, and one on the right side of the MMC.

If there are one or more optional modules attached, remove the four screws that attach the first optional module and remove the MMC from the optional modules.



5. Refer to [Figure 3-8](#) for the location of the battery. Note how the polarity markers are oriented.

Figure 3-8: Battery Location in MMC



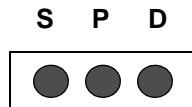
6. Use a screwdriver to gently pry up the battery clip. Slide the battery out. Replace it with a 3V coin cell, + side up:
 - For a Standalone Digital MMC Control (-D32, -D64), use a BR3032 battery
 - For a Standalone MMC control (-A2, -A4, -S8, -S16) or an MMC-DSAXX Control (-DSA2, DSA-4, -DSA8, -DSA16), use a BR2032 battery.

7. Screw the cover or optional modules back on. Return the MMC to the cabinet. Connect the power cable. Turn on power and check the lights.

3.8 System Status Lights

Three lights on the front of the Control (Scan, Power, and Diagnostic labeled “S”, “P”, and “D”), shown in [Figure 3-9](#), provide diagnostic and operational information including power supply status, battery status, diagnostic status, and system status.

Figure 3-9: Status Lights



3.8.1 Power Status

The green Power light (P) indicates that the power supplies internal to the MMC are working properly. If the power light (P) does not go on, or goes off during operation of the system, check that the proper voltage is present at the MMC power connector. If it is, turn off the main disconnect switch and replace the MMC.

3.8.2 Battery Status

Battery Status is reported for the various MMC Controls as follows:

- Standalone MMC Control (-A2, -A4, -S8, -S16) - If the green Power light (P) starts flashing
- Standalone Digital MMC Control (-D32, -D64) and MMC-DSAXX Control (-DSA2, -DSA4, -DSA8, -DSA16) - If the Diagnostic Status Light flashes code 621 (see [section 3.8.6 on page 32](#)).

Follow the battery replacement procedure in [section 3.7.1 on page 29](#).

3.8.3 Scan Status

The green Scan light (S) indicates that the application program is running. If the Scan light does not go on:

1. Check that the power light (P) is ON.
2. Check that the diagnostic light (D) is OFF.
3. Verify that there is a Ladder in the MMC's application memory.

Whenever the scan light is out, the discrete outputs go to the OFF state and the analog outputs are zeroed.

3.8.4 Power-up Diagnostics Status

When the system is powered up, it tests itself and reports the results of the tests using the yellow Diagnostic light (D).

When power is applied to the MMC, the Diagnostic light comes on briefly while its diagnostic tests are running. After the power-up diagnostics run, the Diagnostic light will be in one of the following states:

- off, indicating that the MMC is operating correctly.
- on, indicating that the power-up diagnostics found a hardware problem with the MMC.

NOTE

Power-up diagnostics are run only when the system is powered up. It is possible that a failure might occur during operation. If so, the Diagnostic light remains off. If you suspect that the MMC might be defective, cycle power to run diagnostics again.

3.8.5 Run-time Diagnostic Status

When the application is running (the Scan light is on), the Control constantly monitors the system for proper operation, and the yellow Diagnostic light (D) will be in one of the following states:

- off, indicating that the MMC is operating correctly.
- flashing a three digit error code (see [section 3.8.6 on page 32](#))
- continuously pulsing from bright to dim, indicating one of the following:
 - The Servo Setup Function used in the ladder was compiled with a PiCPro version prior to 16.0. Recompile the Servo Setup Function, then compile and download the ladder with PiCPro 16.0 or greater.
 - The application has accessed an array element beyond the defined array boundary. Avoid this practice.
 - A UDFB is not preceded by the recommended Enable/OK lines. Precede UDFBs with Enable/OK lines as recommended in the Software Manual.
 - An internal software error has occurred. Consult the factory.

3.8.6 Diagnostic Error Codes

While the MMC is running, the Diagnostic light (D) on the CPU module will flash a three digit code signal if there is an error. For example, if there is a long pause-flash-pause-flash-pause-flash-flash-flash-long pause, the code is 123. The errors are described below.

Table 3-3: Diagnostic Light Error Codes

Code	Error	Description
123	Scan too long	A ladder scan loss has occurred because the CPU takes more than 200 ms to scan the application program.
124	Excessive overhead	The system overhead update time is excessive. Consult the factory.
125	Insufficient memory	There is insufficient memory on the CPU to run the current program.

222	Driver error	No driver support on the CPU for the Option module. Update your system EPROMs.
22_	Master rack error	An Option Module in the master rack (or the Motion Control Board in a Standalone MMC Control) do not match what was declared in the hardware master declaration table. The number of flashes in the third digit () identifies the slot number that is in error. The first Option Module is Slot 3.
3_ _	Expansion rack error	The Block I/O modules installed do not match what was declared in the expansion hardware declaration table. The number of flashes in the second and third digits indicates the block I/O module (01 through 77). The second digit will flash a 1 - 7, 10 for 0. The third digit will flash a 1 - 9, 10 for 0. For example, if the second digit flashes 3 times and the third digit flashes 10 times, the module 30 is being reported.
621	Low Battery	The MMC has detected that the on-board battery is low and needs to be replaced as soon as possible (Not for Standalone Digital MMC Control).

4 Standalone MMC Control

4.1 Introduction

This section contains information on the Standalone MMC Control (MMC-A2, -A4, -S8, -S16) only. Information on the Standalone Digital MMC Control (MMC-D32, -D64) is contained in [section 5 on page 95](#), and information on the MMC-DSAXX Control (MMC-DSA2, -DSA4, -DSA8, -DSA16) is contained in [section 6 on page 119](#). Block I/O information can be found in the Block I/O Hardware Manual. Software information can be found in the PiCPro online help, the Function/Function Block Reference Guide, ASFB Manuals or on-line.

4.2 Features

- 32-bit RISC Processor
- 2 Mbytes of flash memory
- 256 Kbytes of Application Memory
- 128 Kbytes of User RAM Memory
- PicPro RS232 port, baud rates up to 57.6 Kbaud
- User RS232/RS485 port, RTS/CTS handshaking, baud rates up to 19.2 Kbaud
- Battery-backed time-of-day clock
- Application stored in battery-back RAM
- Block I/O port for I/O expansion
- Up to 4 MMC Option Modules can be user-installed
- One, two, four, and 16 axis analog versions available
- Eight and 16 axis SERCOS versions available
- UL Listed and CE Marked.

4.3 Overview

The MMC Control consists of a Machine Control board and a Motion Control board contained within a metal enclosure. External connections for the boards are located on the face of the enclosure.

The MMC Control offers a complete solution to both machine and motion control in a standalone unit. The Standalone MMC family includes these models:

- MMC-A2 (2 1/2 axis analog servo control)
- MMC-A2 Plus (2 1/2 axis analog servo control, expandable)
- MMC-A4 (4 1/2 axis analog servo control)
- MMC-A4 Plus (2 1/2 axis analog servo control, expandable)
- MMC-S8 Plus (8 axis SERCOS control)
- MMC-S16 Plus (16 axis SERCOS control)

The PiCPro programming tool used with the PiC family of controls is also used to program the MMC. The built-in I/O [up to 28 inputs (24 VDC) and 16 outputs (24 VDC)] can be expanded using Danaher Motion serially distributed block I/O. There are also eight (four) low current DC and four (two) DC inputs on the Axis connectors of the

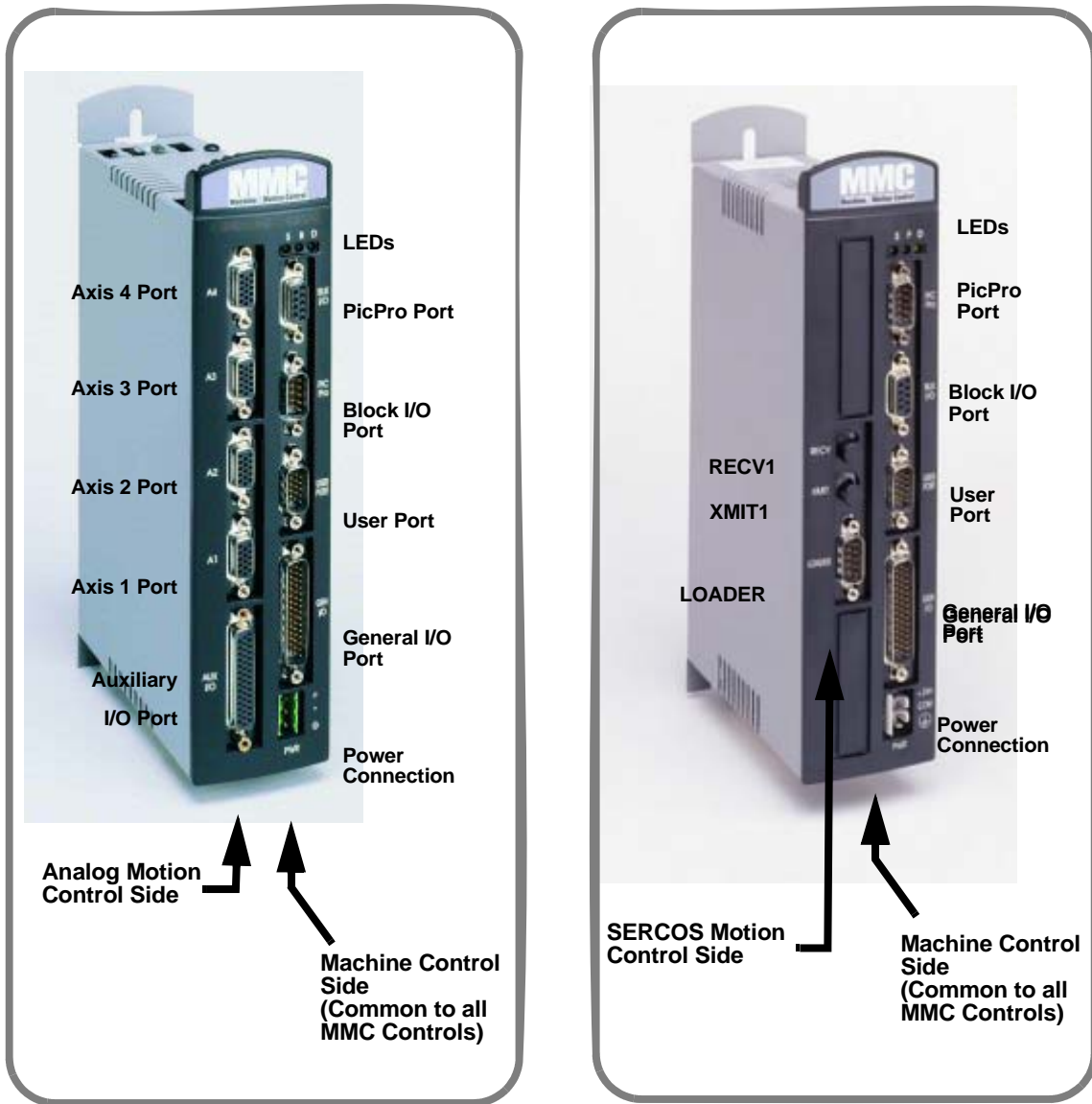
MMC-A4 (MMC-A2). I/O can be added using Danaher Motion's serially distributed Block I/O Modules (covered in the Block I/O Modules Manual).

MMC Option Modules are available to expand the MMC Control. A maximum of two MMC Expansion Modules may be added to the MMC-A2 and MMC A-4. A maximum of four MMC Expansion Modules may be added to the MMC-A2 Plus, MMC A-4 Plus, MMC S-8 Plus, and MMC-S16 Plus.

The following is a list of available MMC Option Modules:

- MMC Ethernet Option Module, see [section 7 on page 151](#).
- MMC DeviceNet Option Module, see [section 8 on page 163](#).
- MMC Profibus Option Module, see [section 9 on page 169](#).
- MMC Axis I/O Option Module (limitations apply), see [section 10 on page 175](#).
- MMC 32 In/32 Out Option Module, see [section 11 on page 181](#).

Figure 4-1: The MMC Control Units



MMC-A4 Servo Control
(MMC-A2 also available)

MMC-S8 SERCOS Control
(MMC-S16 also available)

4.3.1 **Machine Control Board**

The Machine Control Board and its related external connections is located on the right side of the Control. The Machine Control Board contains the CPU. Ladder logic programming is used for machine control. This board also provides a PiCPro Port (RS-232 serial interface for communicating with a computer), User Port (RS-232/RS-485 serial interface for communicating with a serial device), Block I/O Port (proprietary serial interface for communicating with Block I/O Expansion Modules), and a General I/O Port (16 DC outputs and 16 DC inputs).

4.3.2 **Motion Control Board**

The Motion Control Board and its related external connections are located on the left side of the control. The motion control side of the MMC unit can be either an Analog Servo board or a SERCOS board.

4.3.2.1 **Analog Servo board**

The Analog Servo board provides conventional analog/digital interfacing for two or four drives.

The typical signals needed to interface to an analog drive are provided by the analog servo module. The drive command is in the form of an analog voltage ($\pm 10V$). Feedback is accepted from quadrature type encoders with differential outputs. Digital I/O (+24 VDC) is used for drive signals such as enable, reset, and fault. Fast inputs are provided for each encoder input and can be configured to latch encoder position under various conditions.

The analog servo board is offered in both 2 1/2 and 4 1/2 axis configurations. An axis is considered to be an analog output with a corresponding encoder input. In each configuration shown in the following table, note that there is an extra encoder input. This is referred to as a half axis.

Available I/O	2 1/2 Axis	4 1/2 Axis
Analog Inputs	1	1
Analog Outputs	2	4
Encoder Inputs	3	5
Axis DC Inputs	2	4
Axis DC Outputs	4	8
Axis Fast DC Inputs	3	5
AUX I/O Port DC Inputs	6	12

4.3.2.2 SERCOS board

The SERCOS Motion Control board provides a fiber optic input and output for one SERCOS ring (MMC-S8) or two SERCOS rings (MMC-S16). There is also a serial port for field upgrade of the board's FLASH memory.

4.4 Power Supply Requirements

An MMC system consists of a main module (Analog Servo or SERCOS based) and up to four option modules. An external 24 Vdc supply is required to power the MMC's internal circuitry and external I/O. The 24 Vdc is distributed internally to three different buses or sections. When you size your power supply, you must ensure that the supply is large enough to handle the total load and that the maximum current capability of each bus is not exceeded. [Table 4-2](#) below shows the distribution of the 24 Vdc power within the MMC system:

Power Bus	Supplying Current To:	Maximum Current
1	Module Circuitry	3 A
2	General I/O	5 A
3	Module I/O	1 A

In most cases, one power supply can be used for the entire control system. However, depending upon the modules, drives, and external I/O used in your application, you may split the power distribution into two or more power supplies. For example, the Axis I/O on an MMC A2 module can be powered from the MMC, from the drive, or from another external power supply.

Refer to [Table 4-3](#) to size the power supply required by your application. Refer to [Table 4-4](#) to calculate the maximum current required for a theoretical 4 axes MMC.

CAUTION

A possible ignition hazard within the MMC exists if the maximum currents listed for Bus 2 or Bus 3 are exceeded or if excessive current is drawn at the 24 V line going into the MMC. If these currents might be exceeded (due to improper wiring or external device failure), circuit breakers or fuses should be used in series with the 24 Vdc going to and coming from the MMC. Specifically, the circuit breakers or fuses should be sized for 10 A total on the 24 Vdc line coming into the MMC, 1 A total from the +24 Vdc OUT pins of the AXIS and AUXILIARY I/O connectors, and 5 A total from the I/O 24V pins of the GENERAL I/O connector. For maximum protection, use fast blow fuses. When using molded cables supplied by Danaher Motion to connect the MMC to the drives, no overload protection is required.

Table 4-3: 24 VDC Power Supply Sizing Worksheet						
Line	MMC Module	Current (mA)	# of Units	Col A Subtotal (mA)	Col B Current (mA)	
1	MMC-A2 or MMC-A4 (PLUS)	250 (450)				
2	MMC-S8 or MMC-S16 SERCOS PLUS	500				
3	Axis I/O Option Module	100				
4	MMC Ethernet Option Module	200				
5a	MMC DeviceNet Option Module	100				
5b	MMC 32 In/32 Out Option Module	100				
6	Subtotal, Power Bus 1 (Add Column A (3000 mA max))					
Line	MMC Component (Lines 7-12 are for General I/O Port, Lines 14-21 are for Axis I/O Ports)	Max Current (mA)	Actual Current (mA)	Number of I/O	Col A Subtotal (mA)	Col B Current (mA)
7	General Inputs	7.5	7.5			
8	General Outputs	250				
9		250				
10		250				
11		250				
12		250				
13	Subtotal, Power Bus 2 (Add Column A, Lines 7-12, 5000 mA max)					
14	Axis inputs	7.5	7.5			
15	Axis outputs	100				
16		100				
17		100				
18		100				
19	Auxiliary inputs	7.5	7.5			
20	Fast inputs	7.5	7.5			
21	Current supplied by AUX +24					
22	Subtotal Power Bus 3 (Add Column A, Lines 14-21, 1000 mA max)					
23	MMC Power (Add Column B, Lines 6, 13, and 22, 10,000 mA max)					
24	Other (i.e. block I/O)					
25						
26						
27	Subtotal (Add Column A, Lines 24-26)					
28	Total Power (Add Column A, Lines 23 and 27)					

Table 4-4: 24 VDC Power Supply Sizing Worksheet

Line	MMC Module	Current (mA)	# of Units	Col A Subtotal (mA)	Col B Current (mA)	
1	MMC-A2 or MMC-A4 (PLUS)	250 (450)	1	250		
2	MMC-S8 or MMC-S16 SERCOS PLUS	500				
3	Axis I/O Option Module	100				
4	MMC Ethernet Option Module	200				
5a	MMC DeviceNet Option Module	100				
5b	MMC 32 In/32 Out Option Module	100				
6	Subtotal, Power Bus 1 (Add Column A (3000 mA max))				250	
Line	MMC Component (Lines 7-12 are for General I/O Port, Lines 14-21 are for Axis I/O Ports)	Max Current (mA)	Actual Current (mA)	Number of I/O	Col A Subtotal (mA)	Col B Current (mA)
7	General Inputs	7.5	7.5	16	120	
8	General Outputs	250	200	5	1000	
9		250	100	9	900	
10		250				
11		250				
12		250				
13	Subtotal, Power Bus 2 (Add Column A, Lines 7-12, 5000 mA max)				2020	
14	Axis inputs	7.5	7.5	4	30	
15	Axis outputs	100	50	8	200	
16		100			100	
17		100			60	
18		100				
19	Auxiliary inputs	7.5	7.5		120	
20	Fast inputs	7.5	7.5	6	45	
21	Current supplied by AUX +24				400	
22	Subtotal Power Bus 3 (Add Column A, Lines 14-21, 1000 mA max)				955	
23	MMC Power (Add Column B, Lines 6, 13, and 22, 10,000 mA max)				3225	
24	Other (i.e. block I/O)					
25						
26						
27	Subtotal (Add Column A, Lines 24-26)				0	
28	Total Power (Add Column A, Lines 23 and 27)				3225	

4.5 Machine Control Connectors & Operation

This section provides theory-of-operation and connection information on the Machine Control board, which is located on the right side of an MMC Control.

Three lights on the front of the Control (Scan, Power, and Diagnostic) provide operational and diagnostic information, as described in [section 3.8 on page 31](#).

The Machine Control Board does the following:

- Performs diagnostic tests.
- Checks the battery.
- Performs routine maintenance tasks.
- Executes the application program.
- Communicates with the I/O.
- Maintains communication with the workstation through the PiCPro port.
- Maintains communication with the user interface device through the user port. (Details for this communication depend partly on the type of interface device. Refer to the manual that comes with the device.)
- Provides Block I/O expansion capability.

The MMC has a flash chip on board that allows you to load an application program into it. This is standard on the MMC. Having the application in the standard flash chip ensures that you will not lose the application if the battery fails. On power up, the application is transferred from the flash chip to RAM as it is when directly downloaded from PiCPro.

To place the application in flash:

1. Compile the application into a hex file in PiCPro.
2. Use the Download Hex command in PiCPro to download the application into flash.

Even though you have placed an application in flash, you can still download and run a different application from PiCPro. However, when you cycle power on the MMC, the application in flash will always be placed into RAM.

4.5.1 PiCPro Port

The 9-pin male D-sub PiCPro Port connector (labeled "PiCPro" on the front of the Control) provides serial communication between the Control and a computer for the PiCPro programming interface.

- Pin descriptions for are provided in [Table 4-5](#)
- Pin assignments are provided in [Table 4-6](#)
- The available PiCPro Port to PC cable is described in [Table 4-7](#)

Table 4-5: PiCPro Port Pin Descriptions		
Function	Notes	Pin
Receive Data	RS232-level signal that receives serial data from the connected PC running PiCPro.	2
Transmit Data	RS232-level signal that transmits serial data to the connected PC running PiCPro.	3
Signal Ground	Provides the return path for signals	5
Data Terminal Ready	Always high (tied to +12V through 1K resistor)	4
Request-to-send	Always high (tied to +12V through 1K resistor)	7
Shield Ground	Provides a path for shield current through the chassis to an external single point ground.	Connector Shell

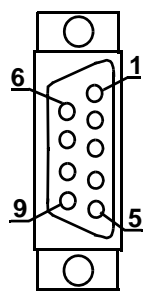
Table 4-6: PiCPro Port Pin Assignments			
Pin	Signal	In/Out	Connector Pinout
1	NC	N/A	9-pin male D-sub 
2	RS232 Receive Data	In	
3	RS232 Transmit Data	Out	
4	Data Terminal Ready	Out	
5	Signal Ground	In/Out	
6	NC	N/A	
7	Request-to-send	Out	
8	NC	N/A	
9	NC	N/A	
Connector Shield	Drain	In	

Table 4-7: PiCPr0 Port to PC Cable				
Part Number: M.1302.8250 Length: 4 M (13 ft) Cable type: 24 AWG, shielded, twisted pair, 4 conductor.				
9-Pin female D-sub (to PiCPro Port, face view)		9-Pin female D-sub (to PC COM Port, face view)		
Pin	Signal	Pin	Signal	Notes
2	Receive Data	3	Transmit Data	Twisted
3	Transmit Data	2	Receive Data	Pair
5	Signal Ground	5	Signal Ground	
Shell	Drain	Shell	Drain	

4.5.2 Block I/O Port

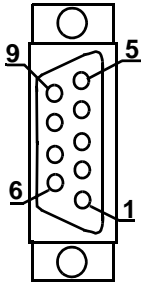
The 9-pin female D-sub PiCPro Port connector (labeled “BLK IO” on the front of the Control) provides serial communication between 1 to 77 Block I/O modules and the Control.

- Pin descriptions for are provided in [Table 4-8](#).
- Pin assignments are provided in [Table 4-9](#).
- The available Flying Lead cable is described in [Table 4-10](#).
- Connections to the Block I/O Module are described in [Table 4-11](#).
- Available Breakout Boxes and Cables are described in [Table 4-12](#).
- Breakout Box dimensions are shown in [Figure 4-2](#)

Table 4-8: Block I/O Port Pin Descriptions

Function	Notes	Pin
Transmit Data +	Transmits data to Block I/O Modules.	3
Transmit Data -	Transmits data to Block I/O Modules.	4
Receive Data +	Receives data from Block I/O Modules.	5
Receive Data -	Receives data from Block I/O Modules.	6
Shield Ground	Provides a path for shield current through the chassis to an external single point ground.	7 & Shell

Table 4-9: Block I/O Port Pin Assignment

Pin	Signal	In/Out	Connector Pinout
1	NC	N/A	9-pin female D-sub 
2	N/C	N/A	
3	Transmit Data +	Out	
4	Transmit Data -	Out	
5	Receive Data +	In	
6	Receive Data -	In	
7	Shield	In	
8	NC	N/A	
9	NC	N/A	
Connector Shell	Drain	In	

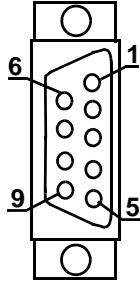
NOTE

Pin 7 of the Block I/O port connector is connected to the connector shell within the MMC. Therefore, the shield may be connected to either pin 7 or the connector shell.

Table 4-10: Block I/O Port to Flying Lead Cable

Part Number: M.1016.2568
 Length: 3 M (10 ft)
 Cable type: 24 AWG, twisted pair (individually shielded), 4 conductor.

9-Pin male D-sub (to Block I/O Port, face view)



Pin	Signal	Color	Notes
3	Transmit Data +	White	Twisted Pair with Shield
4	Transmit Data -	Black	
7	Shield	N/A	
5	Receive Data +	Red	Twisted Pair with Shield
6	Receive Data -	Black	
7	Shield	N/A	

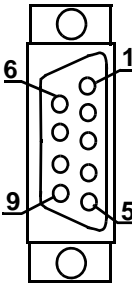
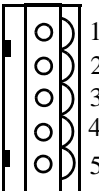
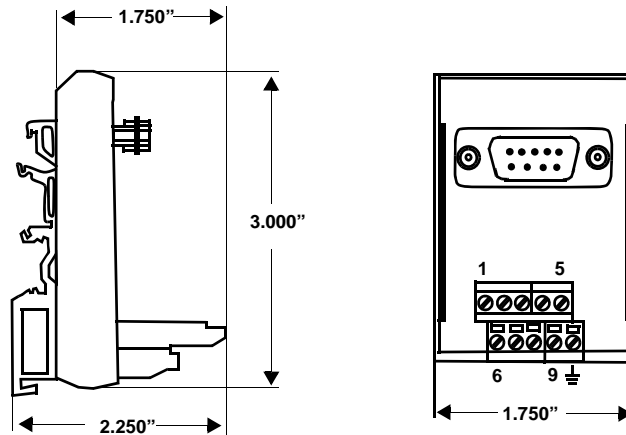
Table 4-11: Block I/O Port to Block I/O Module Wiring				
Use this table to wire from the Block I/O Port to the first Block I/O Module.				
9-Pin male D-sub (to Block I/O Port, face view)		5-Pin Pluggable Screw Terminal (to Block I/O Module, face view)		
				
Pin	Signal	Pin	Signal	Notes
3	Transmit Data +	1	Receive Data +	Twisted Pair
4	Transmit Data -	2	Received Data -	
5	Receive Data +	4	Transmit Data +	Twisted Pair
6	Received Data -	5	Transmit Data -	
7	Shield Ground	3	Shield Ground	
Shell	Drain	Shell	Drain	

Table 4-12: Block I/O Port Breakout Box and Cables ^a		
Description	Length	Part Number
MMC Block I/O Breakout Box	N/A	M.1016.2533
MMC Block I/O Connector to Breakout Box Cable	.3 M (1 ft)	M.1016.2543
MMC Block I/O Connector to Breakout Box Cable	.6 M (2 ft)	M.1016.2544
MMC Block I/O Connector to Breakout Box Cable	.9 M (3 ft)	M.1016.2545

a. The Breakout Box (see [Figure 4-2 on page 49](#)) is DIN-rail mounted, and provides screw terminal wire termination. It can be attached to the “BLK I/O” port on the MMC Control. The pinouts on the terminal strip interface provide a one-to-one transfer of the signals from the connector to the respective pin(s) on the terminal block. The connector pins marked with the “ground” symbol on the screw connector are connected to the “D” connector shell for shield grounding purposes.

Figure 4-2: Block I/O Breakout Box Dimensions

4.5.3 User Port

The 15-pin HD male D-sub User Port connector (labeled “USER PORT” on the front of the Control) provides RS232 and RS485 serial communication between a serial device and the Control

- Pin descriptions are provided in [Table 4-13](#)
- Pin assignments are provided in [Table 4-14](#)
- The available Flying Lead cable is described in [Table 4-15](#).
- The available RS-232 Exter HMI cable is described in [Table 4-16](#).
- The available RS-485 Exter HMI cable is described in [Table 4-17](#).
- Available Breakout Boxes and Cables are described in [Table 4-18](#).
- Breakout Box dimensions are shown in [Figure 4-3](#)

Table 4-13: User Port Pin Descriptions

Function	Notes	Pin
RS232 Receive Data	RS232-level signal that receives serial data from the connected serial device.	9
RS232 Transmit Data	RS232-level signal that sends serial data to the connected serial device.	10
RS232 Request-to-send	RS232-level signal that indicates to the connected serial device that it can transmit data to the Control.	5
RS232 Clear-to-send	RS232-level signal that indicates to the Control that it can transmit data to the connected serial device.	7
RS-232 Data-terminal-ready	This output from the Control is always high (12 Vdc).	4
RS-485 Receive Data +	RS485-level signal that receives serial data from the connected serial device(s).	12
RS-485 Receive Data -	RS485-level signal that receives serial data from the connected serial device(s).	13
RS-485 Transmit Data +	RS485-level signal that transmits serial data to the connected serial device(s).	14
RS-485 Transmit Data -	RS485-level signal that transmits serial data to the connected serial device(s).	15
Signal Ground	Provides the return path for signals	8
Shield Ground	Provides a path for shield current through the chassis to an external single point ground.	Shell

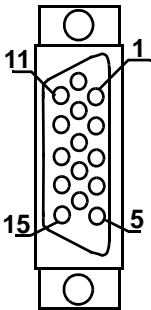
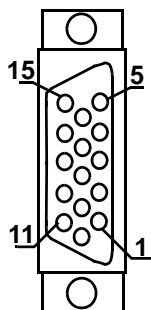
Table 4-14: User Port Pin Assignments			
Pin	Signal	In/Out	Connector Pinout
1	NC	N/A	15-pin HD male D-sub 
2	N/C	N/A	
3	N/C	N/A	
4	RS232 Data-terminal-ready (12 Vdc)	Out	
5	RS232 Request-to-Send	Out	
6	N/C	N/A	
7	RS232 Clear- to-Send	In	
8	Signal Ground	In/Out	
9	RS232 Receive Data	In	
10	RS232 Transmit Data	Out	
11	N/C	N/A	
12	RS485 Receive Data +	In	
13	RS485 Receive Data -	In	
14	RS485 Transmit Data +	Out	
15	RS485 Transmit Data -	Out	
Connector Shell	Drain	In	

Table 4-15: User Port to Flying Lead Cable

Part Number: M.1016.2565
 Length: 3 M (10 ft)
 Cable type: 28 AWG, shielded, twisted pair, 16 conductor.

15-Pin HD female D-sub (to User Port, face view)

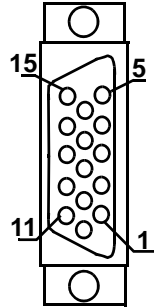


Pin	Signal	Color	Notes
3	N/C	Blue	Twisted
8	Signal Ground	Blue/Black	Pair
12	RS485 Receive Data +	Brown	Twisted
13	RS485 Receive Data -	Brown/Black	Pair
14	RS485 Transmit Data +	Violet	Twisted
15	RS485 Transmit Data -	Violet/Black	Pair
4	RS232 Data-terminal Ready	White	
5	RS232 Request-to-send	Red	
7	RS232 Clear-to-send	Green	
9	RS232 Receive Data	Yellow	
10	RS232 Transmit Data	Orange	
Shell	Drain	N/A	

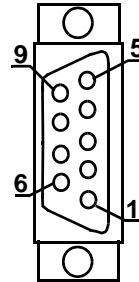
Table 4-16: User Port to RS-232 Exter HMI Cable

Part Number: M.1302.8453
 Length: 4 M (13 ft)
 Cable type: 24 AWG, shielded, twisted pair, 4 conductor.

15-Pin HD female D-sub
 (to User Port, face view)



9-Pin female D-sub (to
 Exter HMI COM2 Port,
 face view)



Pin	Signal	Pin	Signal	Notes
9	Receive Data	3	Transmit Data	Twisted Pair
10	Transmit Data	2	Receive Data	
8	Signal Ground	5	Signal Ground	
Shell	Drain	Shell	Drain	

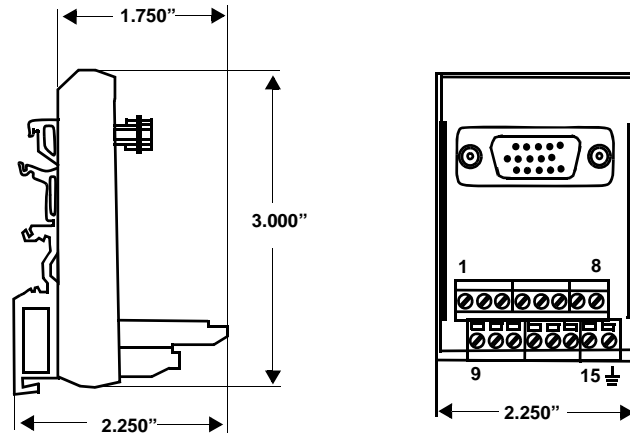
Table 4-17: User Port to RS-485 Exter HMI Cable

Part Number: M.1302.8454 Length: 4 M (13 ft) Cable type: 24 AWG, shielded, twisted pair, 6 conductor.				
15-Pin HD female D-sub (to User Port, face view)		25-Pin male D-sub (to Exter HMI COM1 Port, face view)		
Pin	Signal	Pin	Signal	Notes
12	Receive Data+	2	Transmit Data+	Twisted
13	Receive Data-	15	Transmit Data-	Pair
14	Transmit Data+	3	Receive Data+	Twisted
15	Transmit Data-	16	Receive Data-	Pair
8	Signal Ground	7	Signal Ground	
Shell	Drain	Shell	Drain	

Table 4-18: User Port Breakout Box and Cables^a

Description	Length	Part Number
MMC User Port Breakout Box	N/A	M.1016.2530
MMC User Port to Breakout Box Cable	.3 M (1 ft)	M.1016.2715
MMC User Port to Breakout Box Cable	.6 M (2 ft)	M.1016.2716
MMC User Port to Breakout Box Cable	.9 M (3 ft)	M.1016.2717

a. The Breakout Box (see [Figure 4-3 on page 55](#)) is DIN-rail mounted, and provides screw terminal wire termination. It can be attached to the “USER PORT” connector on the MMC Control. The pinouts on the terminal strip interface provide a one-to-one transfer of the signals from the connector to the respective pin(s) on the terminal block. The connector pins marked with the “ground” symbol on the screw connector are connected to the “D” connector shell for shield grounding purposes.

Figure 4-3: User Port Breakout Box Dimensions

4.5.4 General I/O Port

The 44-pin HD male D-sub General I/O Port connectors (labeled “GEN I/O” on the front of the Control) provides connection between user I/O devices and the Control. This port provides 16 source-only outputs (described in detail in [section 4.5.4.1 on page 59](#)), and 16 sink or source inputs (described in detail in [section 4.5.4.2 on page 62](#)).

- Pin descriptions are provided in [Table 4-19](#)
- Pin assignments are provided in [Table 4-20](#)
- The available Flying Lead cable is described in [Table 4-21](#).
- Available Breakout Boxes and Cables are described in [Table 4-22](#).
- Breakout Box dimensions are shown in [Figure 4-4](#)

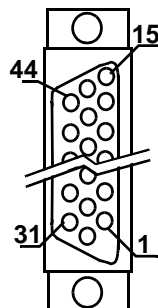
Table 4-19: General I/O Port Pin Descriptions		
Function	Notes	Pin
DC Outputs 1-16	Nominal 24 Vdc Outputs capable of sourcing up to 250 ma.	1-16
DC Inputs 1-8	Nominal 24 Vdc Inputs (Sink or Source) Inputs 1-8	23-30
Sink/Source select pin for DC Inputs 1-8	To make DC Inputs 1-8 “sourcing” inputs (24 Vdc applied to the DC Input turns the input “on”), connect 24 Vdc Common to this pin. To make DC Inputs 1-8 “sinking” inputs (24 Vdc Common applied to the DC Input turns the input “on”), connect 24 Vdc (nominal) to this pin.	21
DC Inputs 9-16	24 Vdc (nominal) Inputs (Sink or Source) 9-16.	37-44
Sink/Source select pin for DC Inputs 9-16	To make DC Inputs 9-16 “sourcing” inputs (24 Vdc applied to the DC Input turns the input “on”), connect 24 Vdc Common to this pin. To make DC Inputs 9-16 “sinking” inputs (24 Vdc Common applied to the DC Input turns the input “on”), connect 24 Vdc (nominal) to this pin.	35
24 Vdc Out	24 Vdc power (nominal) is routed from the 3-pin Power connector to these pins. Connect the Sink/Source select pin (described above) to this pin to configure the associated Inputs as “sinking” inputs.	20, 34
24 Vdc Common	24 Vdc Common is routed from the 3-pin Power connector to these pins. Connected the Sink/Source select pin (described above) to this pin to configure the associated Inputs as “sourcing” inputs.	22, 36
Shield Ground	Provides a path for shield current through the chassis to an external single point ground.	Shell

Table 4-20: General I/O Port Pin Assignments					
Pin	Signal	In/Out	Connector Pinout		
1	DCOUT1	Out	<p>44-pin HD male D-sub</p>		
2	DCOUT2	Out			
3	DCOUT3	Out			
4	DCOUT4	Out			
5	DCOUT5	Out			
6	DCOUT6	Out			
7	DCOUT7	Out			
8	DCOUT8	Out			
9	DCOUT9	Out			
10	DCOUT10	Out			
11	DCOUT11	Out			
12	DCOUT12	Out			
13	DCOUT13	Out			
14	DCOUT14	Out			
15	DCOUT15	Out			
16	DCOUT16	Out			
17-19	N/C	N/A	Pin	Signal	In/Out
20	IO24V	Out	34	IO24V	Out
21	DCSS1	In	35	DCSS2	In
22	IO24C	Out	36	IO24C	Out
23	DCIN1	In	37	DCIN9	In
24	DCIN2	In	38	DCIN10	In
25	DCIN3	In	39	DCIN11	In
26	DCIN4	In	40	DCIN12	In
27	DCIN5	In	41	DCIN13	In
28	DCIN6	In	42	DCIN14	In
29	DCIN7	In	43	DCIN15	In
30	DCIN8	In	44	DCIN16	In
31-33	N/C	N/A	Shell	Drain	In

Table 4-21: General I/O Port to Flying Lead Cable

Part Number: M.1016.2567
 Length: 3 M (10 ft)
 Cable type: 28 AWG, shielded, twisted pair, 44 conductor.

44-Pin HD female D-sub (to Gen I/O Port, face view)

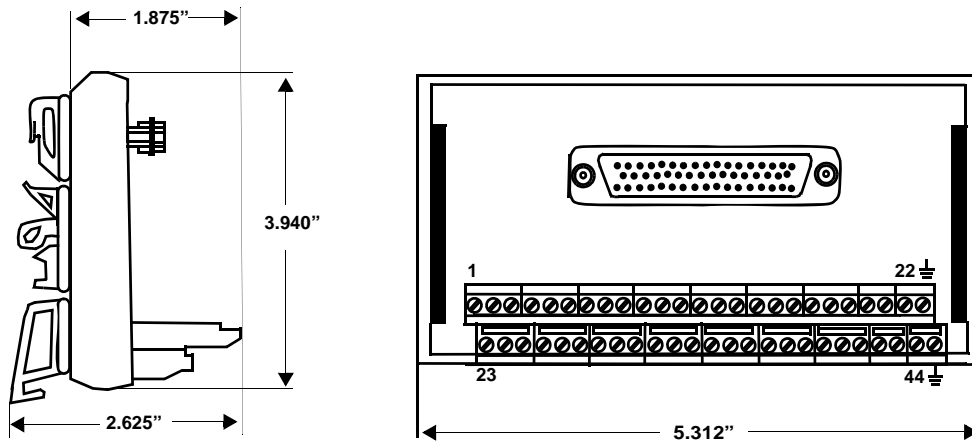


Pin	Signal	Color	Notes	Pin	Signal	Color	Notes
1	DCOUT1	Black	Twisted	22	IO24C	Red	Twisted
2	DCOUT2	Red	Pair	23	DCIN1	Brown	Pair
3	DCOUT3	Black	Twisted	24	DCIN2	Red	Twisted
4	DCOUT4	White	Pair	27	DCIN5	Orange	Pair
5	DCOUT5	Black	Twisted	25	DCIN3	Green	Twisted
6	DCOUT6	Green	Pair	26	DCIN4	White	Pair
7	DCOUT7	Black	Twisted	28	DCIN6	Green	Twisted
8	DCOUT8	Blue	Pair	29	DCIN7	Blue	Pair
9	DCOUT9	Black	Twisted	31	None	Green	Twisted
10	DCOUT1	Yellow	Pair	32	None	Yellow	Pair
11	DCOUT1	Black	Twisted	33	None	Green	Twisted
12	DCOUT1	Brown	Pair	34	IO24V	Brown	Pair
13	DCOUT1	Black	Twisted	35	DCSS2	Green	Twisted
14	DCOUT1	Orange	Pair	36	IO24C	Orange	Pair
15	DCOUT1	Red	Twisted	37	DCIN9	White	Twisted
30	DCIN8	White	Pair	38	DCIN10	Blue	Pair
16	DCOUT1	Red	Twisted	39	DCIN11	White	Twisted
17	None	Green	Pair	40	DCIN12	Yellow	Pair
18	None	Red	Twisted	41	DCIN13	White	Twisted
21	DCSS1	Blue	Pair	42	DCIN14	Brown	Pair
19	None	Red	Twisted	43	DCIN15	White	Twisted
20	IO24V	Yellow	Pair	44	DCIN16	Orange	Pair
Shell	Drain	N/A					

Description	Length	Part Number
MMC Gen I/O Breakout Box	N/A	M.1016.2532
MMC Gen I/O & Aux I/O Connector to Breakout Box Cable	.3 M (1 ft)	M.1016.2539
MMC Gen I/O & Aux I/O Connector to Breakout Box Cable	.6 M (2 ft)	M.1016.2540
MMC Gen I/O & Aux I/O Connector to Breakout Box Cable	.9 M (3 ft)	M.1016.2541

a. The Breakout Box (see [Figure 4-4 on page 59](#)) is DIN-rail mounted, and provides screw terminal wire termination. It can be attached to the “GEN I/O” port on the MMC Control, and on the “GEN I/O A” and “GEN I/O B” ports on the MMC 32 In/32 Out Expansion module. The pinouts on the terminal strip interface provide a one-to-one transfer of the signals from the connector to the respective pin(s) on the terminal block. The connector pins marked with the “ground” symbol on the screw connector are connected to the “D” connector shell for shield grounding purposes.

Figure 4-4: General I/O Port Breakout Box Dimensions



4.5.4.1 DC Output Operation

The General I/O Port provides 16 source-only 24 Vdc outputs. Each of the 16 outputs on the general I/O connector is a solid state switch rated at 250 ma. An example of connecting the DC Outputs to loads is shown in [Figure 4-5](#).

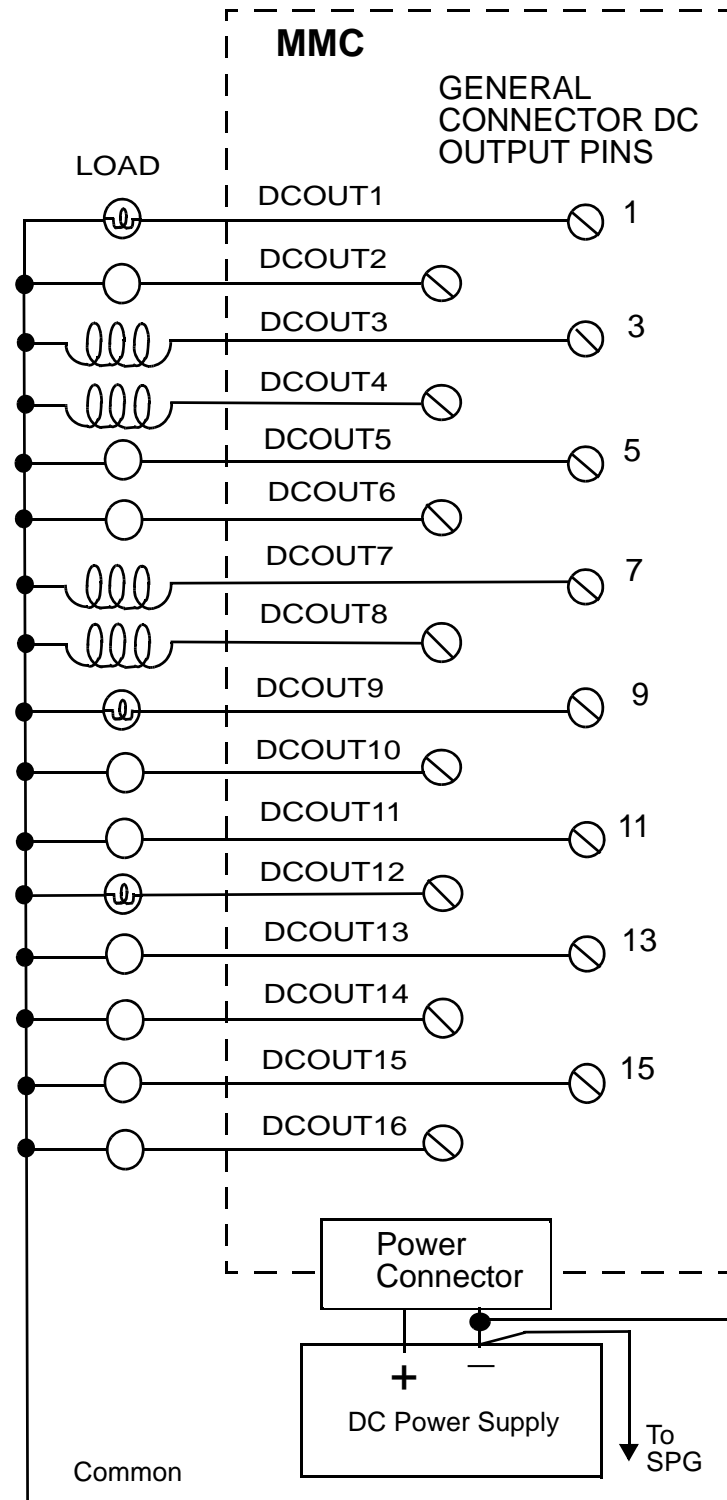
There are two groups of eight outputs: group A = output 1 through output 8, group B = output 9 through output 16. Each group is capable of detecting a short circuit condition. When a short circuit condition is sensed, all outputs in the group are turned off and remain off for approximately 100 ms regardless of ladder activity. After 100 ms, the ladder again controls the outputs. In addition, each output is protected with

internal clamping diodes. Without clamping, high voltage transients (kickback) from inductive loads might damage the module.

For safety reasons, all outputs turn off (no current flow) when a scan loss condition occurs.

For more information on DC output operation, refer to [Section A.3 on page 206 of Appendix A](#).

Figure 4-5: General I/O Outputs Connected to Loads



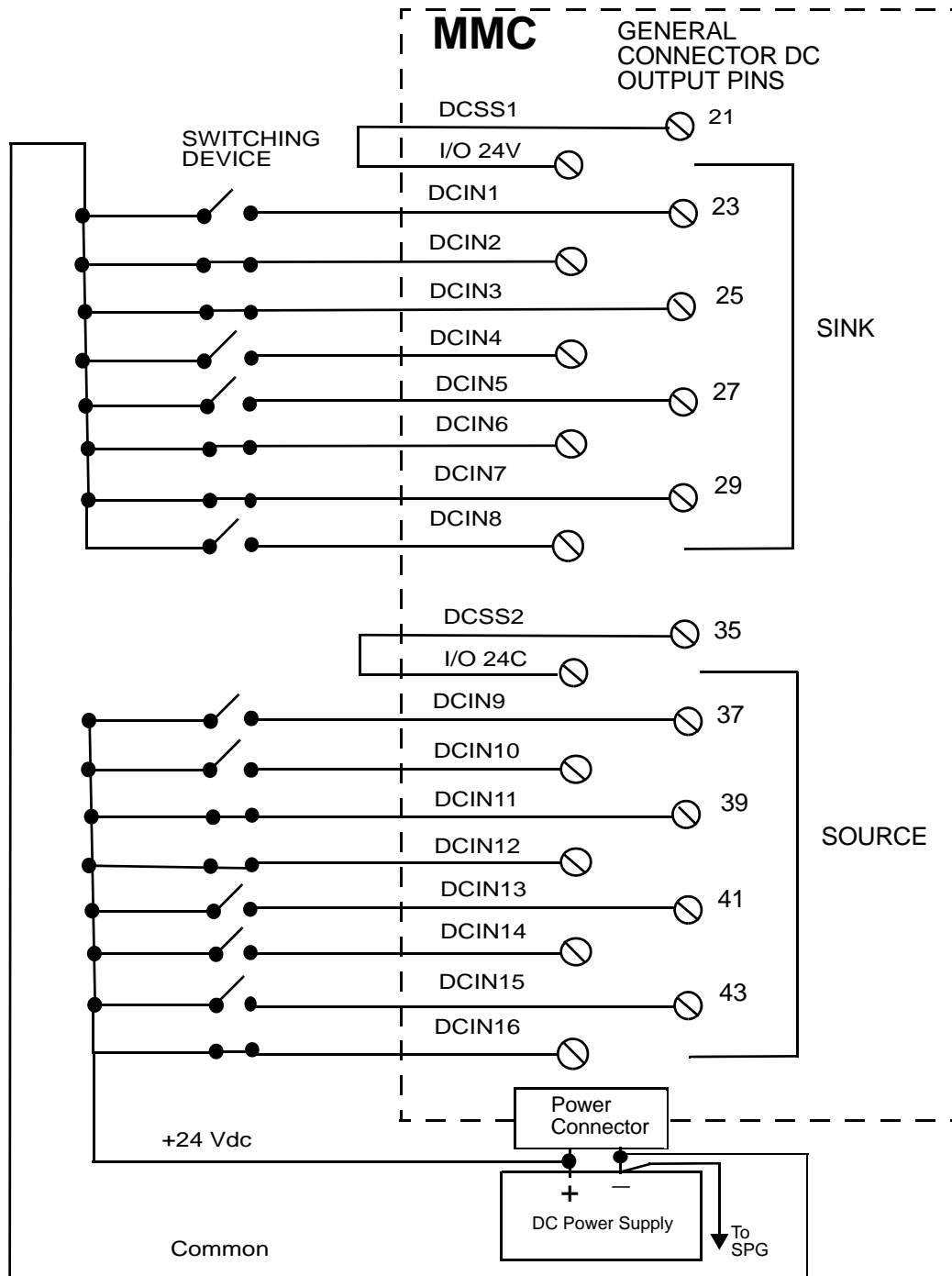
4.5.4.2 DC Input Operation

The General I/O Port provides sixteen 24 Vdc inputs. There are two groups of eight inputs: group A = input 1 through output 8, group B = input 9 through output 16. Each group can be configured as sourcing or sinking. Connect the DCSS pin (DCSS1 for Group A, DCSS2 for Group B) to IO24C for a sourcing configuration. Connect the DCSS pin (DCSS1 for Group A, DCSS2 for Group B) to +24 Vdc for a sinking configuration. An example of connecting input devices in both a sink and source configuration is shown in [Figure 4-6](#).

In addition, the first input of each Group (Input 1 of Group A, and input 9 of Group B), can be programmed to provide a processor interrupt on either a low-to-high or high-to-low transition.

For more information on DC input operation, refer to [Section A.2 on page 205 of Appendix A](#).

Figure 4-6: General I/O Inputs Connected to Devices



4.5.5 Power Connection

The Power connector (labeled “PWR” on the front of the Control) must be connected to a user-supplied +24 VDC power supply to provide power to the Control. The power supply screw terminal connection (3 pin) is at the bottom of the CPU section of the MMC. This +24 Vdc appears as an output at several points on the MMC connectors. [Figure 4-7](#) illustrates the pin-out.

The MMC converts +24 Vdc power from this connector to DC power at voltages of +5 Vdc, + 15 Vdc, and -15 Vdc and supplies them to the logic side of the system. The same supply that powers the Control can be used for the field side of the system. Optionally, an external power supply (or supplies) can be used for the field side of the system. Such supplies are not routed through the MMC, but they should all have the same power cut-off switch as the Control.

The 24 VDC applied at the MMC input power connector is also available:

- To power the DC outputs
- To power the sink/source inputs
- To power the axes interface
- To power any attached MMC Option Modules

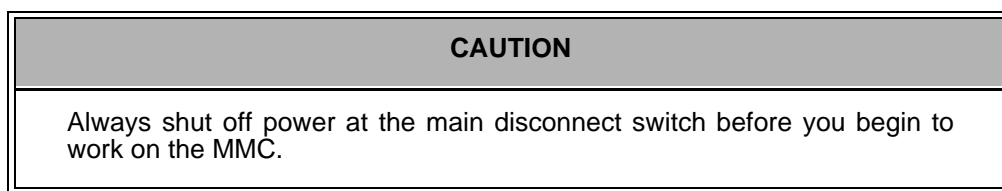
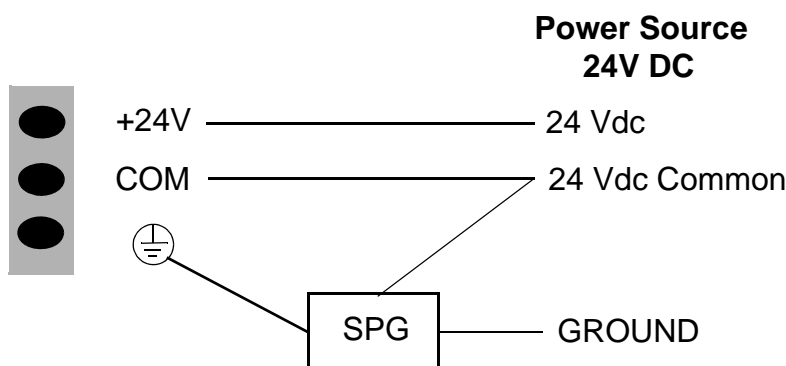


Figure 4-7: Pin Out for the 3-pin Power Supply Screw Terminal Connection



4.6 Analog Motion Control Connectors & Operation

This section provides theory-of-operation and connection information on the Analog Motion Control board, which is located on the left side of an MMC Control.

4.6.1 Axis I/O Ports

The 15-pin HD female D-sub Axis I/O Port connectors (labeled “A1”, “A2”, “A3”, and “A4” on the front of the Control) provide connection between analog drives and the Control by providing the following:

- Two 24 Vdc outputs, described in detail in [section 4.6.1.1 on page 69](#).
- One DC input, described in detail in [section 4.6.1.2 on page 71](#).
- One 16-bit resolution analog output, described in detail in [section 4.6.1.3 on page 72](#).
- One quadrature, incremental encoder input, described in detail in [section 4.6.1.4 on page 73](#).

Additional information is provided in this section as follows:

- Pin descriptions provided in [Table 4-23](#)
- Pin assignments are provided in [Table 4-24](#)
- Available MMC Smart Drive cables are described in [Table 4-25](#).
- The available Flying Lead cable is described in [Table 4-26](#).
- Available Breakout Boxes and Cables are described in [Table 4-27](#).
- Breakout Box dimensions are shown in [Figure 4-8](#)

Table 4-23: Axis I/O Port Pin Descriptions		
Function	Notes	Pin
Encoder Input (A, A/, B, B/, I, I/)	Provides connections to an incremental encoder having differential outputs.	1-5, 10
D/A Output (DA+, DA-)	+/- 10V D/A output for controlling an analog drive having a differential input.	8, 9
DC Input (DCIN+, DCIN-)	Provides connection to an input device (sink or source).	6, 7
DC Outputs (DCOUT1, DCOUT2)	Provides connection to an output device (sink or source).	13, 14
DCOSS	Connect this pin to +24 Vdc to configure the outputs (DCOUT1 & DCOUT2) as sinking-type, and to +24 Vdc Common to configure the DC Outputs (DCOUT1 & DCOUT2) as sourcing-type.	15
24 Vdc out	24 Vdc output to be used to power connected input and/or output devices.	11
COM	24 Vdc Common used to provide the 24 Vdc return path for sinking-type outputs.	12
Shield Ground	Provides a path for shield current through the chassis to an external single point ground.	Shell

Table 4-24: Axis I/O Port Pin Assignments

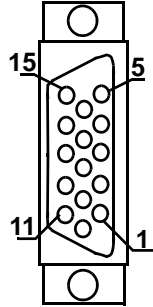
Pin	Signal	In/Out	Connector Pinout
1	A	In	<p>15-pin HD female D-sub</p> 
2	A/	In	
3	B	In	
4	B/	In	
5	I	In	
6	DCIN+	In	
7	DCIN-	Out	
8	D/A+	Out	
9	DA-	Out	
10	I/	In	
11	+24 Vdc	Out	
12	COM	In	
13	DCOUT1	In/Out	
14	DCOUT2	In/Out	
15	DCOSS	In/Out	
Connector Shell	Drain	In	

Table 4-25: Axis I/O Port to MMC Smart Drive Cable

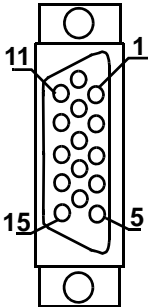
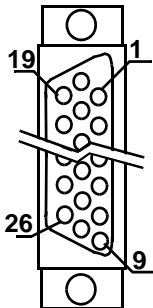
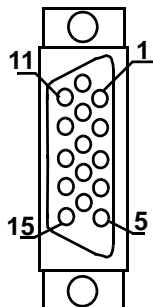
Part Numbers: .5 M (1.6 ft): M.1302.5990 2.5 M (8.2 ft): M.1302.7714 1 M (3.3 ft): M.1302.5991 3.5 M (11.5 ft): M.1302.7715 1.5 M (4.9 ft): M.1301.5992 5 M (16.4 ft): M.1302.7537 2 M (6.6 ft): M.1302.5993 Cable type: 28 AWG, shielded, twisted pair, 18 conductor.				
15-Pin HD male D-sub (to Axis I/O Port, face view) 		26-Pin HD male D-sub (to MMC Smart Drive I/O Port, face view) 		
Pin	Signal	Pin	Signal	Notes
1	A	1	A	Twisted
2	A/	2	A/	Pair
3	B	3	B	Twisted
4	B/	4	B/	Pair
5	I	5	I	Twisted
10	I/	6	I/	Pair
11	+24 Vdc	10	IO24V	Twisted Pair
12	COM	16	IOCOM	(20 AWG)
13	DCOUT1	17	IN1	Twisted
14	DCOUT2	18	IN2	Pair
6	DCIN+	26	OUT4	
7	DCIN -			Jumpered
12	COM			
15	DCOSS			Jumpered
11	+24 Vdc			
Shell	Drain	Shell	Drain	

Table 4-26: Axis I/O Port to Flying Lead Cable

Part Number: M.1016.2519
 Length: 3 M (10 ft)
 Cable type: 28 AWG, shielded, twisted pair, 16 conductor.

15-Pin HD male D-sub (to Axis I/O Port, face view)

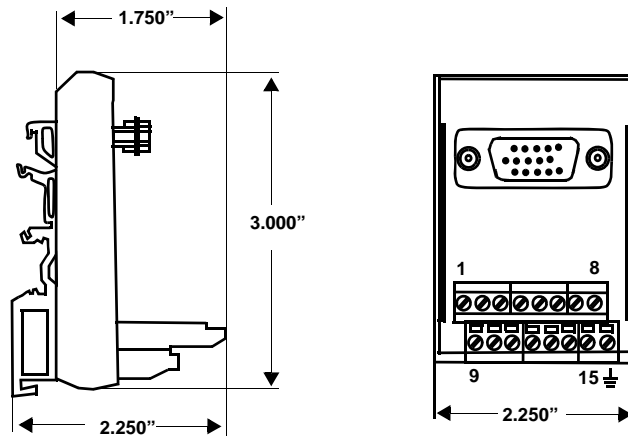


Pin	Signal	Color	Notes
1	A	Blue	Twisted
2	A/	White/Blue	Pair
3	B	Black	Twisted
4	B/	White/Black	Pair
5	I	Red	Twisted
10	I/	White/Red	Pair
8	D/A+	Green	Twisted
9	D/A -	White/Green	Pair
6	DCIN+	Yellow	Twisted
7	DCIN-	White/Yellow	Pair
11	+24 Vdc	Orange	Twisted
11	+24 Vdc	White/Orange	Pair
12	COM	Brown	Twisted
13	DCOUT1	White/Brown	Pair
14	DCOUT2	Violet	Twisted
15	DCOSS	White/Violet	Pair
Shell	Drain	N/A	

Description	Length	Part Number
Axis Connector Breakout Box	N/A	M.1016.2529
MMC Axis A"n" to Breakout Box Cable	.3 M (1 ft)	M.1016.2535
MMC Axis A"n" to Breakout Box Cable	.6 M (2 ft)	M.1016.2536
MMC Axis A"n" to Breakout Box Cable	.9 M (3 ft)	M.1016.2537

a. The Breakout Box (see [Figure 4-8 on page 69](#)) is DIN-rail mounted, and provides screw terminal wire termination. It can be attached to the A1, A2, A3, and A4 ports on the Standalone MMC Control or the MMC Axis I/O Option Module. The pinouts on the terminal strip interface provide a one-to-one transfer of the signals from the connector to the respective pin(s) on the terminal block. The ground pin on the terminal strip provides a connection to the metal D-shell.

Figure 4-8: Axis I/O Port Breakout Box Dimensions



4.6.1.1 Axis I/O Port DC Outputs

Each Axis I/O Port provides 2 sink or source 24 Vdc outputs. Each of the 2 outputs consists of an optically isolated solid state switch rated at 100 ma. It turns on or off according to the logic state sent to it by the CPU. When the switch turns on, current flows through the switch. When the switch turns off, current flow stops. When the DCOSS pin is tied to the +24V, the outputs will be in a source configuration as shown in [Figure 4-9](#). When the DCOSS pin is tied to COMMON, the outputs will be in a sink configuration as shown in [Figure 4-10](#).

These outputs are intended to interface with the drive enable and drive reset inputs.

For safety reasons, all outputs turn off (no current flow) when a scan loss condition occurs.

For more information on DC output operation, refer to [Section A.3 on page 206 of Appendix A](#).

Figure 4-9: Axis I/O DC Output Source Configuration

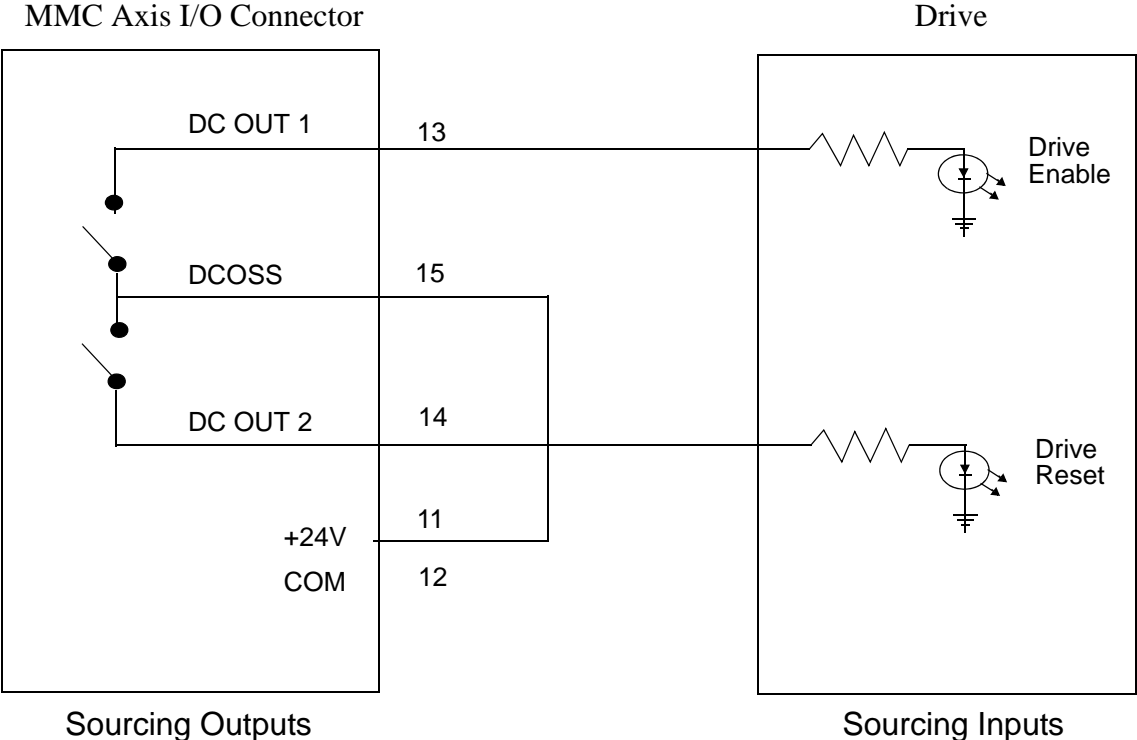
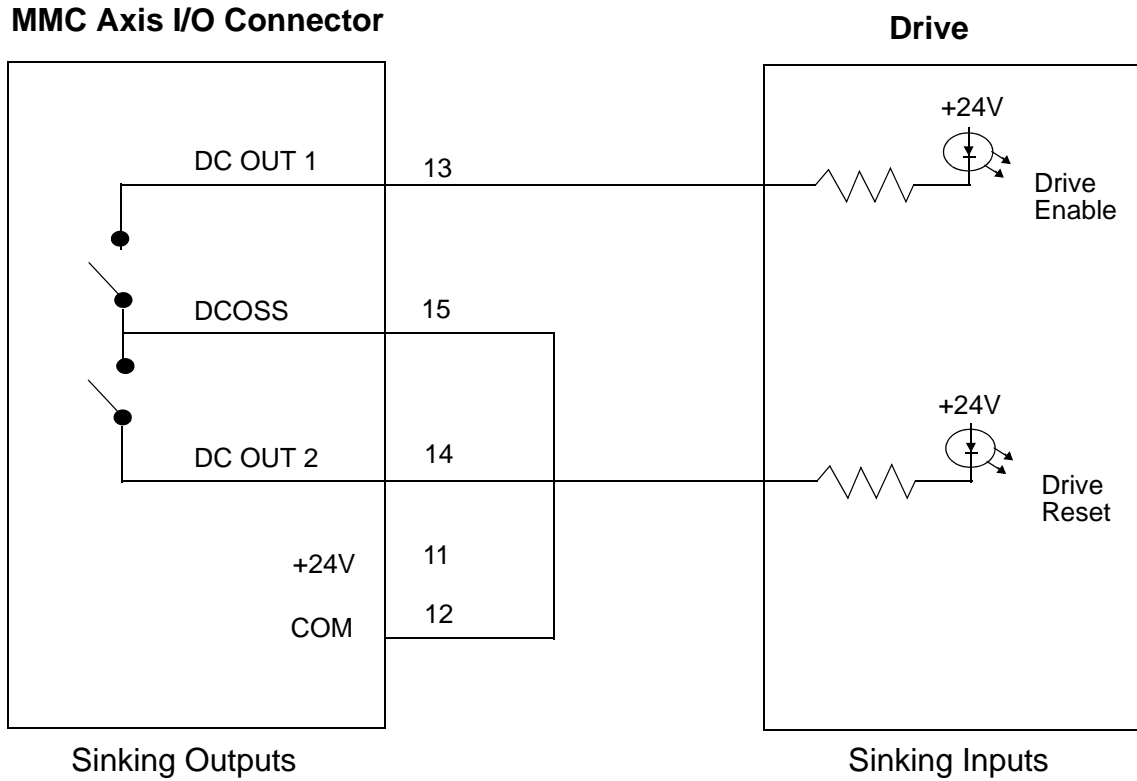


Figure 4-10: Axis I/O DC Output Sink Configuration



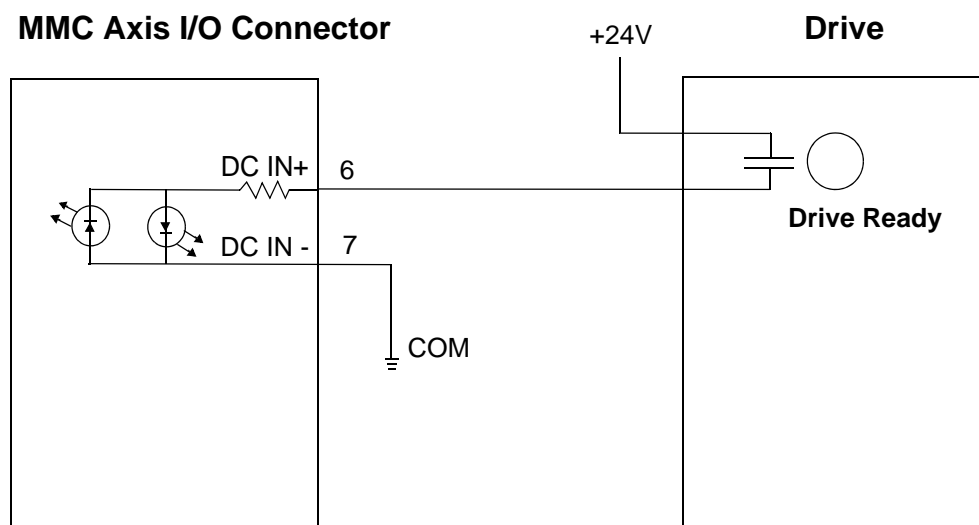
4.6.1.2 Axis I/O Port DC Input

Each Axis I/O Port provides one 24 Vdc input. Each input consists of an optically isolated solid state switch that can be wired in either a sourcing or sinking configuration. The input is turned on or off by the connected external device. One of the input pins should be connected to either +24 Vdc or COM. The remaining input pin should be tied to the input device. Refer to [Figure 4-11](#).

This input is intended to interface with the drive ready output.

For more information on DC input operation, refer to [Section A.2 on page 205 of Appendix A](#).

Figure 4-11: Axis I/O Port DC Input



4.6.1.3 Axis I/O Port Analog Output

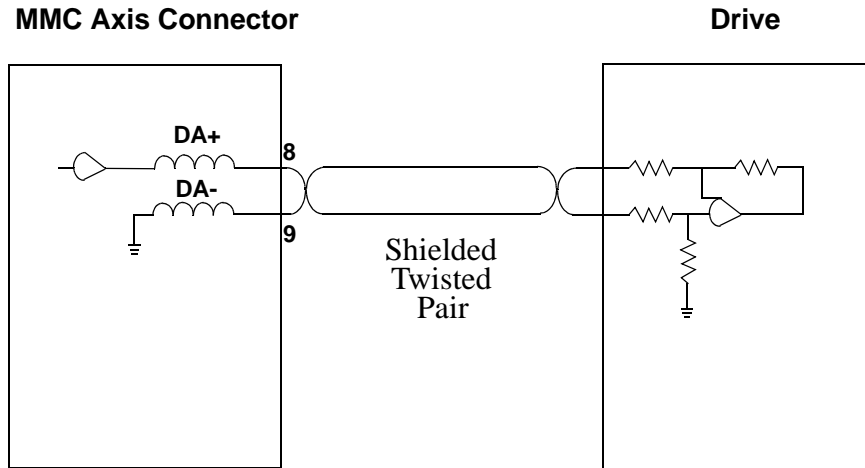
The Axis I/O Port provides a ± 10 V differential Analog Output. The Analog Output is typically connected to the drive Command Input. Only shielded twisted pair wire should be used to make the connection between the analog output and the drive as shown in [Figure 4-12](#).

The CPU sends the analog output section a 16-bit digital word to each analog output channel. Each digital word is converted to a corresponding voltage within the range of ± 10 Vdc. The voltage is buffered and brought out to a pair of I/O connections as a differential type voltage output. This output is less subject to interference from electrical noise than a single-ended output would be.

You can adjust each analog output channel in software for offset adjustments, gain scaling, and unipolar outputs.

For safety reasons, all outputs are automatically reset to 0 Vdc when a scan loss condition occurs.

Figure 4-12: Axis Port D/A Output



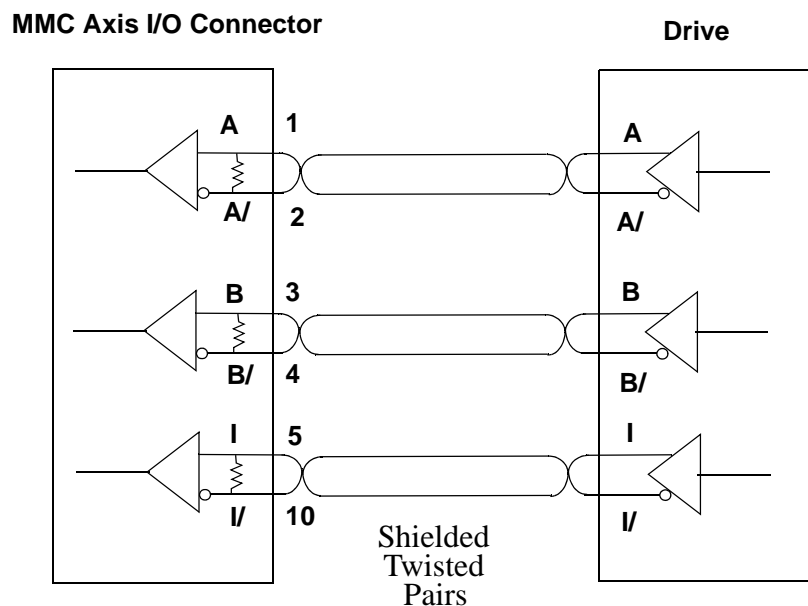
4.6.1.4 Axis I/O Port Encoder Input

The Axis I/O Port provides an input for a differential incremental encoder. The encoder output signals from the drive should be connected to the Axis I/O Port encoder input for each axis. The Axis I/O Port encoder input accepts RS422 differential inputs. The encoder signals should be quadrature type. All encoder wiring between the MMC and the drive should be shielded twisted pair as shown in [Figure 4-13](#).

For more information on the Encoder input operation, refer to [Section A.4 on page 207 of Appendix A](#).

NOTE
<p>The power supply that powers the encoder must be referenced to the power supply that powers the MMC. This is done by connecting the “common” terminal of each supply back to Single Point Ground. Failure to observe this precaution may result in sporadic encoder operation and/or damage to the MMC.</p>

Figure 4-13: Axis Port MMC Encoder Input



4.6.2

Aux I/O Port

The 44-pin HD female D-sub Auxiliary I/O Port connector (labeled "AUX I/O" on the front of the Control) provides connection to an incremental encoder and various I/O devices by providing the following inputs to the Control:

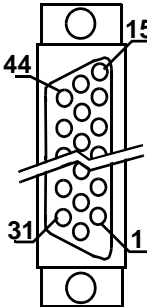
- Five fast DC inputs, described in detail in [section 4.6.2.2 on page 81](#).
- 12 optically isolated DC inputs, described in detail in [section 4.6.2.3 on page 83](#).
- One quadrature, incremental encoder channel, described in detail in [section 4.6.2.4 on page 84](#).
- One 12-bit resolution analog input channel, described in detail in [section 4.6.2.5 on page 85](#).

Additional information is provided in this section as follows:

- Pin descriptions are provided in [Table 4-28](#)
- Pin assignments are provided in [Table 4-29](#)
- The available Flying Lead cable is described in [Table 4-30](#).
- Available Breakout Boxes and Cables are described in [Table 4-31](#).
- Breakout Box dimensions are shown in [Figure 4-14](#)

Table 4-28: Aux I/O Port Pin Descriptions		
Function	Notes	Pin
Encoder Input (A, A/, B, B/, I, I/)	Provides connections to an incremental encoder having differential outputs.	1-6
DC Input 1-6 (DCIN1-DCIN12)	Provides connection to an input device (sink or source).	32-37
DC Input 7-12 (DCIN1-DCIN12)	Provides connection to an input device (sink or source).	39-44
DC Sink/Source A (DCSSA)	If this pin is connected to +24 Vdc, inputs 1-6 are “sinking”. If this pin is connected to +24 Common, inputs 1-6 are “sourcing”.	31
DC Sink/Source B (DCSSB)	If this pin is connected to +24 Vdc, inputs DCIN1-DCIN6 are “sinking”. If this pin is connected to +24 Common, inputs DCIN7-DCIN12 are “sourcing”.	38
Analog Input (ANLGIN+, ANLGIN-)	+/- 10V 16-bit A/D input	13,14
Fast Inputs 1-5 (FASTIN1-5+, FASTIN1-5-)	Differential Fast Inputs for latching Encoder position.	16, 17, 19, 20, 22, 23, 25, 26, 28, 29
24 Vdc out	24 Vdc output to be used to power connected input and/or output devices.	8, 9
COM	24 Vdc Common used to provide the 24 Vdc return path for sinking-type outputs.	10, 11
+5 Vdc Out	+5 Vdc output to be used to power connected encoder (150 ma maximum).	12
Shield Ground	Provides a path for shield current through the chassis to an external single point ground.	7, 15, 18, 21, 24, 27, 30, Shell

Table 4-29: Aux I/O Port Pin Assignment

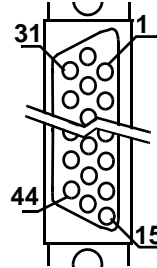
Pin	Signal	In/Out	Pin	Signal	In/Out	Connector Pinout
1	A	In	25	FASTIN4+ ^(a)	In	44-pin HD female D-sub 
2	A/	In	26	FASTIN4- ^(a)	In	
3	B	In	27	Shield	In	
4	B/	In	28	FASTIN5+	In	
5	I	In	29	FASTIN5-	In	
6	I/	In	30	Shield	In	
7	Shield-	In	31	DCSSA	In/Out	
8, 9	+24 Vdc Out	Out	32	DCIN1	In	
10, 11	COM	In	33	DCIN2	In	
12	+5 Vdc Out	Out	34	DCIN3	In	
13	ANLGIN+	In	35	DCIN4	In	
14	ANLGIN-	In	36	DCIN5	In	
15	Shield	In	37	DCIN6	In	
16	FASTIN1+	In	38	DCSSB ^(a)	In/Out	
17	FASTIN1-	In	39	DCIN7 ^(a)	In	
18	Shield	In	40	DCIN8 ^(a)	In	
19	FASTIN2+	In	41	DCIN9 ^(a)	In	
20	FASTIN2-		42	DCIN10 ^(a)	In	
21	Shield		43	DCIN11 ^(a)	In	
22	FASTIN3+ ^a		44	DCIN12 ^(a)	In	
23	FASTIN3- ^(a)		Shell	Drain	In	
24	Shield					

a. Signal not available on MMC-A2

Table 4-30: Aux I/O Port to Flying Lead Cable

Part Number: M.1016.2566
 Length: 3 M (10 ft)
 Cable type: 28 AWG, shielded, twisted pair, 44 conductor.

44-Pin HD male D-sub (to Aux I/O Port, face view)



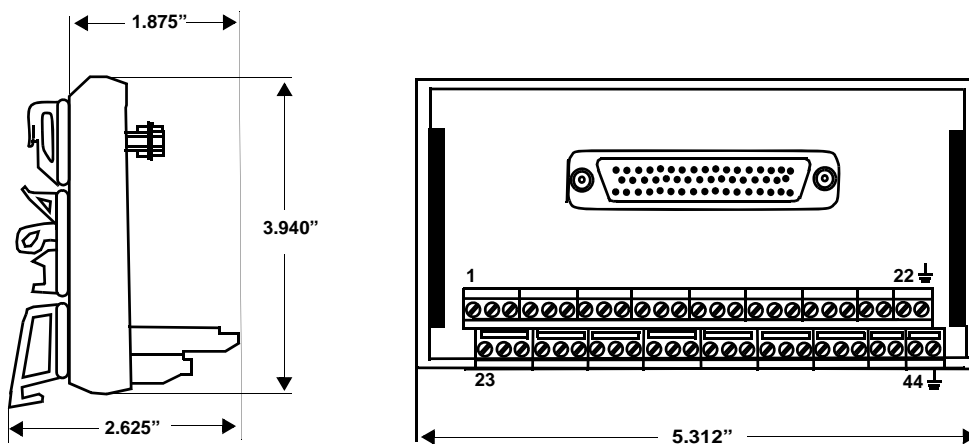
Pin	Signal	Color	Notes	Pin	Signal	Color	Notes
1	A	Black	Twisted	22	FASTIN3+	Red	Twisted
2	A/	Red	Pair	23	FASTIN3-	Brown	Pair
3	B	Black	Twisted	24	Shield	Red	Twisted
4	B/	White	Pair	27	Shield	Orange	Pair
5	I	Black	Twisted	25	FASTIN4+	Green	Twisted
6	I/	Green	Pair	26	FASTIN4-	White	Pair
7	Shield	Black	Twisted	28	FASTIN5+	Green	Twisted
8	+ 24 Vdc	Blue	Pair	29	FASTIN5-	Blue	Pair
9	+ 24 Vdc	Black	Twisted	31	DCSSA	Green	Twisted
10	COM	Yellow	Pair	32	DCIN1	Yellow	Pair
11	COM	Black	Twisted	33	DCIN2	Green	Twisted
12	+5 Vdc Out	Brown	Pair	34	DCIN3	Brown	Pair
13	ANLGIN+	Black	Twisted	35	DCIN4	Green	Twisted
14	ANLGIN-	Orange	Pair	36	DCIN5	Orange	Pair
15	Shield	Red	Twisted	37	DCIN6	White	Twisted
30	Shield	White	Pair	38	DCSSB ^(a)	Blue	Pair
16	FASTIN1+	Red	Twisted	39	DCIN7 ^(a)	White	Twisted
17	FASTIN1-	Green	Pair	40	DCIN8 ^(a)	Yellow	Pair
18	Shield	Red	Twisted	41	DCIN9 ^(a)	White	Twisted
21	Shield	Blue	Pair	42	DCIN10 ^(a)	Brown	Pair
19	Fastin2+	Red	Twisted	43	DCIN11 ^(a)	White	Twisted
20	Fastin2-	Yellow	Pair	44	DCIN12 ^(a)	Orange	Pair
Shell	Drain	N/A					

a. Signal not available on MMC-A2

Table 4-31: Aux I/O Port Breakout Box and Cables ^a		
Description	Length	Part Number
MMC Aux I/O Breakout Box ^b	N/A	M.1016.2531
MMC Aux I/O Breakout Box with Encoder Isolation ^c	N/A	M.1017.4236
MMC Gen I/O & Aux I/O Connector to Breakout Box Cable	.3 M (1 ft)	M.1016.2539
MMC Gen I/O & Aux I/O Connector to Breakout Box Cable	.6 M (2 ft)	M.1016.2540
MMC Gen I/O & Aux I/O Connector to Breakout Box Cable	.9 M (3 ft)	M.1016.2541

- a. The Breakout Box (see [Figure 4-14 on page 78](#)) is DIN-rail mounted, and provides screw terminal wire termination. It can be attached to the AUX I/O port on the Standalone MMC Control or the MMC Axis I/O Option Module. Both a standard Breakout Box as well as a Breakout Box that provides encoder isolation are available. The pinouts on the terminal strip interface provide a one-to-one transfer of the signals from the connector to the respective pin(s) on the terminal block. The connector pins marked with the “ground” symbol on the screw connector are connected to the “D” connector shell for shield grounding purposes.
- b. Aux I/O Breakout Box dimensions are shown in [Figure 4-14](#).
- c. See [section 4.6.2.1 on page 79](#) for details on the Breakout Box with Encoder Isolation.

Figure 4-14: Aux I/O Port Breakout Box Dimensions



4.6.2.1 Isolated Breakout Box Details

The Isolated Breakout Box is different than the Standard Breakout Box in three ways:

- The Isolated Breakout Box provides optical isolation between the encoder (A, A/, B, B/, I, I/) signals and the Control. This boosts the encoder common mode voltages allowed from approximately 10 volts to hundreds of volts. This allows reliable encoder operation in the presence of large amounts of electrical noise and ground disturbances relative to the Control.
- Since the Isolated Breakout Box uses +5 Vdc from pin 12 of the Control to power its internal circuitry, there is no +5 Vdc current to power the encoder. Therefore, the pin 12 screw terminal on the Isolated Breakout Box does not carry +5 Vdc, and the encoder must be powered by an external supply.
- When using the Isolated Breakout Box, the “index” inputs (I, I/) must be connected. If the connected encoder does not provide the index function, connect I on the Breakout Box to +5 Vdc, and I/ to +5 Vdc Common. Failure to connect I and I/ will result in a “loss-of-feedback” by the Control.

Figure 4-15: Connections from Encoder to Encoder Isolated AUX I/O

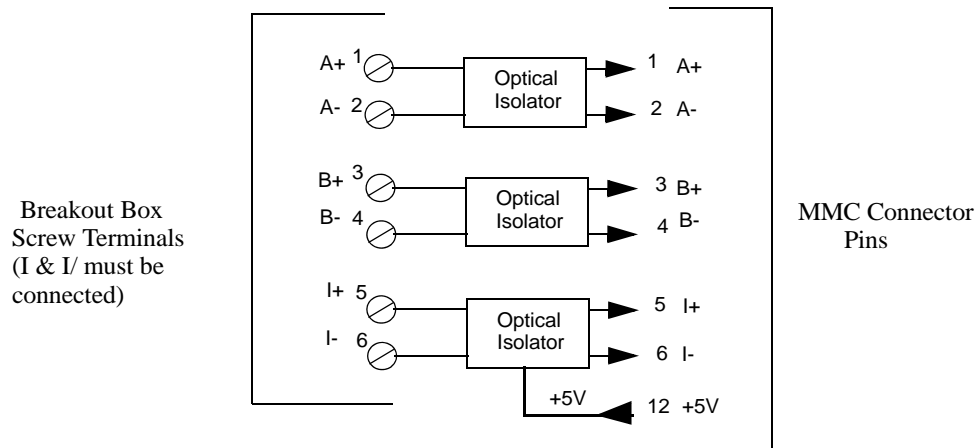


Figure 4-16: Encoder and Power Connections for Encoder Isolator

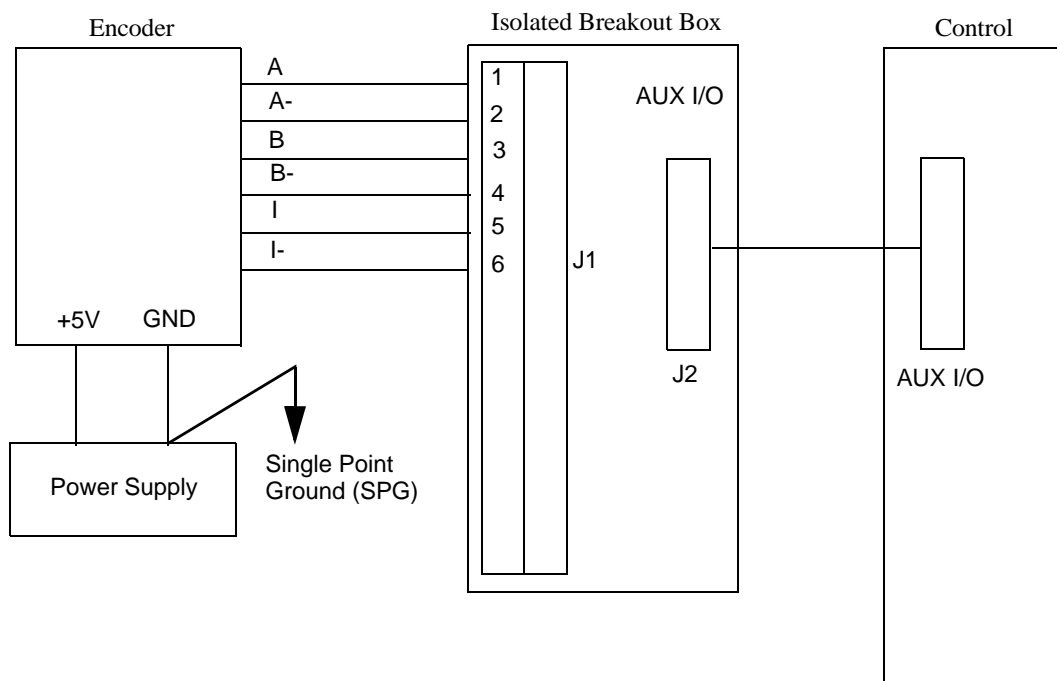


Table 4-32: Encoder Specifications

Item	Specification
Encoder Driver Required	RS-422 differential
Recommended Encoder Drivers	7272, 75183, 8830, 75114, 9614, 26LS31 (or equivalent)
Differential Input Voltage Range	2.5 volts to 7.0 volts
Differential Input Current Range	2.5 ma (Input Voltage = 2.5 volts) to 30ma (Input Voltage = 7.0 volts)
Input pulse width (minimum)	600 nanoseconds
Input frequency (maximum) on A or B inputs from Quadrature output encoder	250KHz (1.0 MHz count rate, using quadrature edges)
Input frequency (maximum) on A or B inputs from Pulse output encoder	500KHz (500KHz count rate)

IMPORTANT

When using the Isolated Breakout Box, the “index” inputs (I, I/) must be connected. If the connected encoder does not provide the index function, connect I on the Breakout Box to +5 Vdc, and I/ to +5 Vdc Common. Failure to connect I and I/ will result in a “loss-of-feedback” by the Control.

4.6.2.2 Aux I/O Port Fast Inputs

The Aux I/O Port provides one fast 24 Vdc input for each encoder input, as follows:

Fast Input Association - Aux I/O Port	
Fast Input	Encoder
FASTIN1	Axis 1
FASTIN2	Axis 2
FASTIN3	Axis 3
FASTIN4	Axis 4
FASTIN5	Aux I/O

The fast input can be used to latch the encoder position under various conditions. Shielded twisted pair wiring should be used for all fast input connections. The fast inputs can be connected in either a source or sink configuration. The source configuration is illustrated in [Figure 4-17](#), and the sink configuration is illustrated in [Figure 4-18](#).

Figure 4-17: Fast Inputs Connected Using Shielded Twisted Pair (Source)

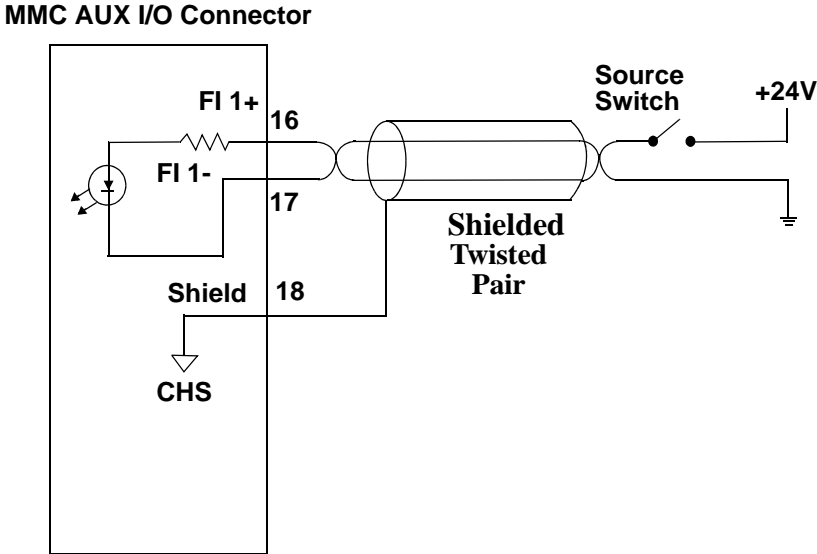
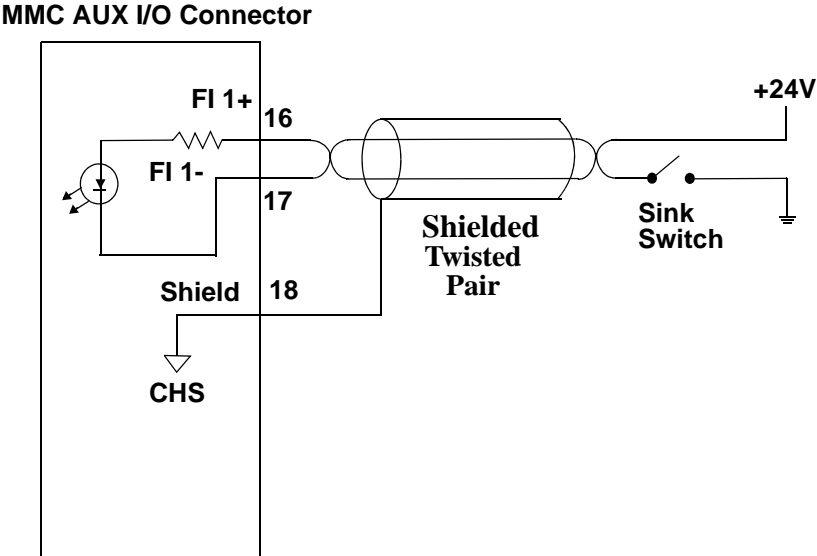


Figure 4-18: Fast Inputs Connected Using Shielded Twisted Pair (Sink)



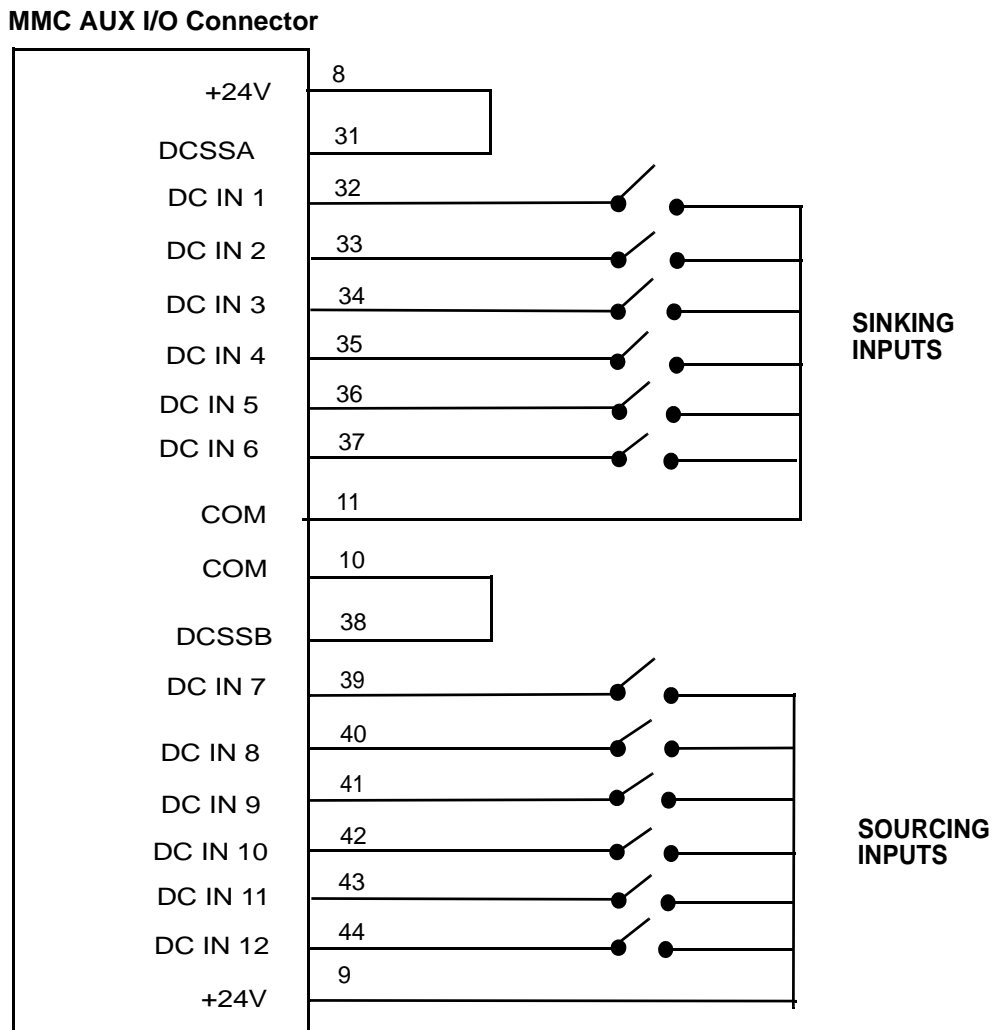
4.6.2.3 Aux I/O Port DC Inputs

The Aux I/O Port provides 12 general purpose 24 Vdc inputs. The inputs are configured as two groups of six. Each group can be configured as sourcing or sinking. Connect the DCSS pin to COM for a sourcing configuration by connecting the DCSS pin to either the COM pin on the Aux I/O Port or to the Common of an external supply. Connect the DCSS pin to +24 Vdc for a sinking configuration by connecting the DCSS pin to either the +24 Vdc pin on the Aux I/O Port or to the +24 Vdc of an external supply. Both sinking and sourcing configurations, using the Aux I/O +24V and COM pins, are shown in [Figure 4-19](#).

All 12 inputs are available on the four axis MMC-A4, and 6 inputs are available on the two axis MMM-A2.

For more information on DC input operation, refer to [Section A.2 on page 205 of Appendix A](#).

Figure 4-19: Aux I/O Port Inputs



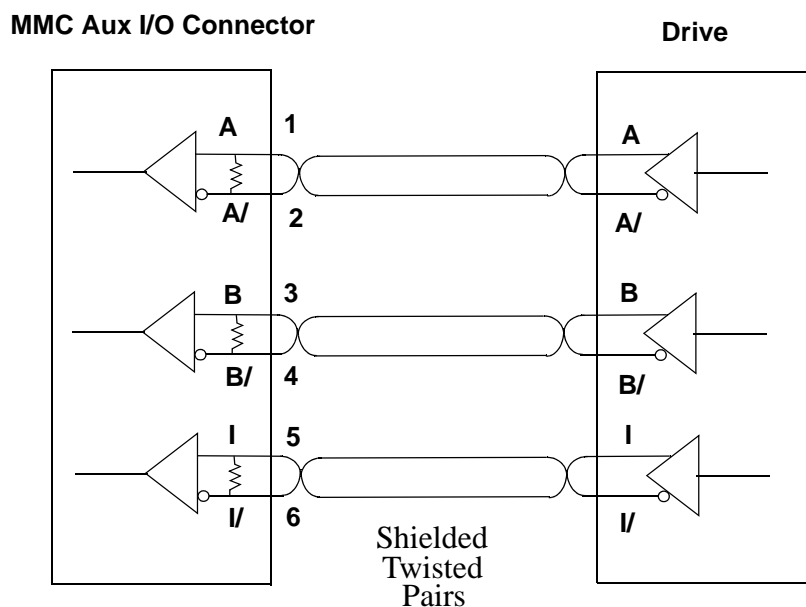
4.6.2.4 Aux I/O Port Encoder Input

The Aux I/O Port provides an input for a differential incremental encoder. This encoder is typically used as a digitizing (read only) axis. This axis then acts as a “master” axis, and the other servo axis are “slaved” to its position. The Aux I/O Port encoder input accepts RS422 differential inputs. The encoder signals should be quadrature type. All encoder wiring between the MMC and the drive should be shielded twisted pair as shown in [Figure 4-20](#).

For more information on the Encoder input operation, refer to [Section A.4 on page 207 of Appendix A](#).

NOTE
<p>The power supply that powers the encoder must be referenced to the power supply that powers the MMC. This is done by connecting the “common” terminal of each supply back to Single Point Ground. Failure to observe this precaution may result in sporadic encoder operation and/or damage to the MMC.</p>

Figure 4-20: Aux Port MMC Encoder Input



4.6.2.5 Aux I/O Port Analog Input

The Aux I/O Port provides one differential analog input channel. The input range is ± 10 VDC. The analog input voltage is sampled every 100 μ sec by a 12-bit A/D converter. The most recent conversion result is stored in an on-board register. This register can be read at any time by the application.

The analog input signal passes through a common mode and differential mode filter prior to being applied to the A/D converter. These filters improve the noise immunity of the module.

4.7 SERCOS Motion Control Connections & Operation

This section provides information on connecting to the SERCOS Motion Control board, which is located on the left side of a SERCOS MMC Control.

The MMC SERCOS board is an alternate type of motion control used as part of an MMC base unit. It provides an interface between the MMC and 1 fiber optic ring (MMC-S8) or 2 fiber optic rings (MMC-S16). A ring can have from one to eight SERCOS slaves. The module contains an on board processor. The MMC-S8 has one SERCOS ring port located at the center of the module. The MMC-S16 has an additional ring port located at the top of the module. Each ring port has a receive and a transmit fiber optic connector. There is also an RS232 port used for loading FLASH memory updates.

The SERCOS board is controlled by an application created in PiCPro. An on-board processor interprets the functions and performs appropriate operations according to the SERCOS communications protocol.

Data Transfer Rates of 2 Mbaud, 4 Mbaud, 8 Mbaud, and 16 Mbaud are available, and Update Rates of 1 msec, 2 msec, 4 msec, and 8 msec are available.

If a scan loss occurs, SERCOS communications are reset. There is no communication with the SERCOS slaves until they are re-initialized.

4.7.1 SERCOS Receive and Transmit Ports

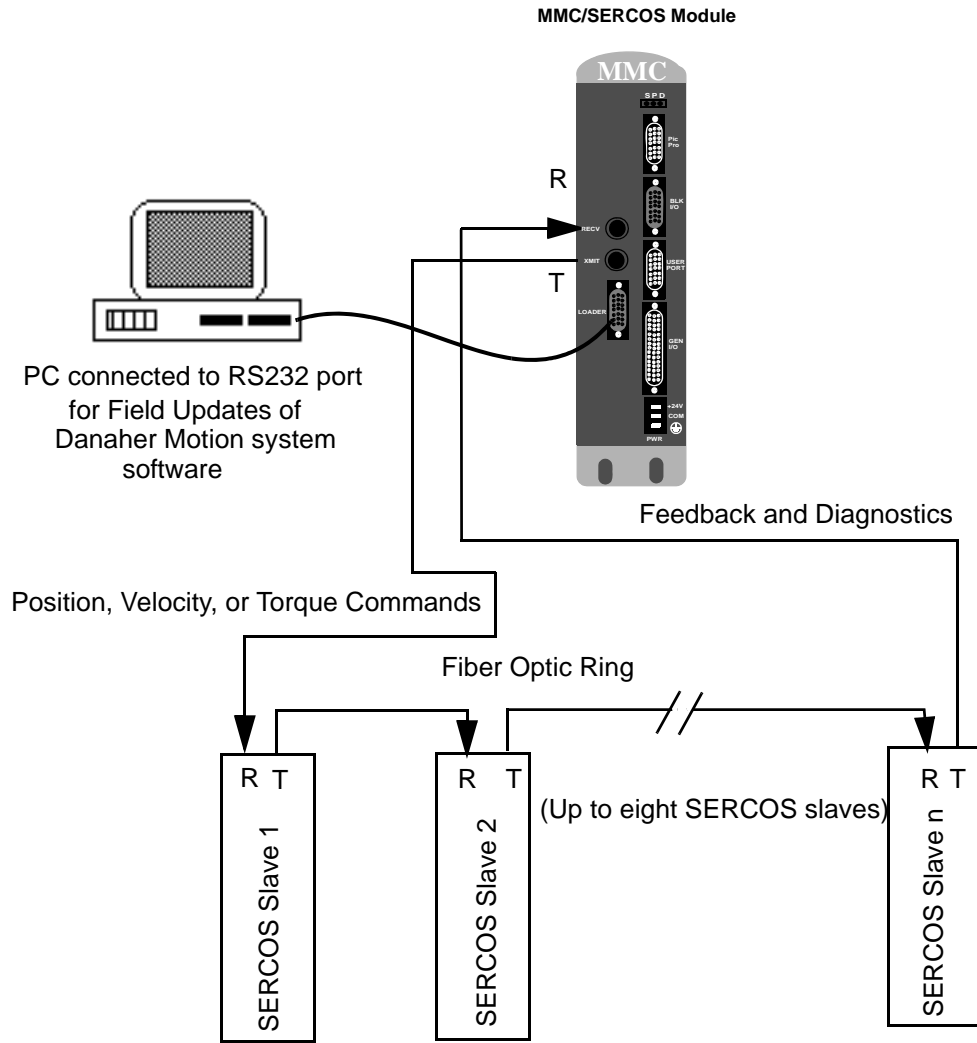
The SERCOS Receive Port and Transmit Port connectors (labeled "RECV1" and "XMIT1" on the front of the Module) located at the center of the module can connect to one SERCOS ring. On an MMC-S16, there is a second Receive Port connector and a second Transmit Port connector (labeled "RECV2" and "XMIT2" on the front of the Module) located at the top of the module that can connect to another SERCOS ring. The connection to each ring is made through a pair of female fiber optic SMA connectors. The module's transmitter is connected to the first receiver in the loop and the module's receiver is connected to the last transmitter in the loop.

Available SERCOS cables are shown in [Table 4-33](#).

Description	Model Number	Length	Part Number
Heavy Duty SERCOS Ca- ble	SERCOS-0.50m-6mm-AA	.5 M (1.6 ft)	M.1302.6379
	SERCOS-1.00m-6mm-AA	1 M (3.3 ft)	M.1302.6400
	SERCOS-2.00m-6mm-AA	2 M (6.6 ft)	M.1302.6401
	SERCOS-3.00m-6mm-AA	3 M (9.8 ft)	M.1302.6402
	SERCOS-5.00m-6mm-AA	5 M (16.4 ft)	M.1302.6403
	SERCOS-10.00m-6mm-AA	10 M (32.8 ft)	M.1302.6404
	SERCOS-15.00m-6mm-AA	15 M (49.2 ft)	M.1302.6405
	SERCOS-30.00m-6mm-AA	30 M (98.4 ft)	M.1302.6406

a. SERCOS Cables can be used to make the connection between a Standalone MMC SERCOS Control and a SERCOS Drive, and between SERCOS drives.

Figure 4-21: SERCOS Connections - One Ring



4.7.2 Loader Port

The 9-pin male D-sub Loader Port connector (labeled “LOADER” on the front of the Module) provides a serial connection to a PC to enable the user to update the FLASH memory on the Module.

- Pin descriptions for are provided in [Table 4-34](#)
- Pin assignments are provided in [Table 4-35](#)
- The available SERCOS Loader Port to PC cable is described in [Table 4-36](#)

Table 4-34: SERCOS Loader Port Pin Descriptions

Function	Notes	Pin
Receive Data	RS232-level signal that receives serial data from the connected PC running PiCPro.	2
Transmit Data	RS232-level signal that transmits serial data to the connected PC running PiCPro.	3
Signal Ground	Provides the return path for signals	5
Shield Ground	Provides a path for shield current through the chassis to an external single point ground.	Connector Shell

Table 4-35: SERCOS Loader Port Pin Assignments

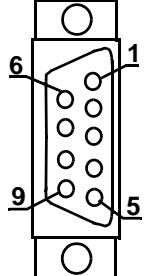
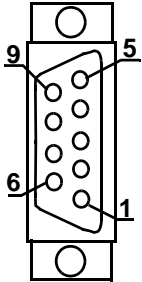
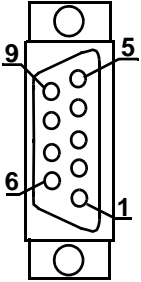
Pin	Signal	In/Out	Connector Pinout
1	NC	N/A	9-pin male D-sub 
2	RS232 Receive Data	In	
3	RS232 Transmit Data	Out	
4	NC	N/A	
5	Signal Ground	In/Out	
6	NC	N/A	
7	NC	N/A	
8	NC	N/A	
9	NC	N/A	
Connector Shield	Shield	In	

Table 4-36: SERCOS Loader Port to PC Cable

Part Number: M.1302.8250 Length: 4 M (13 ft) Cable type: 24 AWG, shielded, twisted pair, 4 conductor.				
9-Pin female D-sub (to SERCOS Loader Port, face view)		9-Pin female D-sub (to PC COM Port, face view)		
				
Pin	Signal	Pin	Signal	Notes
2	Receive Data	3	Transmit Data	Twisted
3	Transmit Data	2	Receive Data	Pair
5	Signal Ground	5	Signal Ground	
Shell	Drain	Shell	Drain	

4.8 Specifications

Characteristic		MMC Specifications				Number of servo axes available at six update rates*					
Model	Part Number	Speed	App Mem	RAM Mem	User Mem	8 ms	4 ms	2 ms	1 ms	.5 ms	.25 ms
MMC-A2	M.1017.3772	Std.	256K	128K	64K	2	2	2	2	2	1
MMC-A2 Plus	M.1302.7095	X3	256K	128K	64K	18	18	16	8	3	1
MMC-A4	M.1017.3774	Std.	256K	128K	64K	4	4	4	4	2	1
MMC-A4 Plus	M.1302.7096	X3	256K	128K	64K	20	20	16	8	3	1
MMC-S8 Plus	M.1302.7479	X3	256K	128K	64k	8	8	8	4		
MMC-S16 Plus	M.3000.0472	X3	256K	128K	64K	16	16	8	4		

* Using features such as servo tasks, S-curve, RATIO_RL, M_LINCIR, M_SCRVLC, PLS, and CAM_OUT places a heavier burden on available CPU time. Consult Danaher Motion for assistance if you want to exceed the number of axes in this chart.

CPU	32 bit RISC processor with numeric coprocessor
Battery	3V Coin Cell, BR2032 lithium battery
CAUTION for Lithium Batteries Danger of explosion if battery is incorrectly replaced. Replace only with the same or equivalent type recommended by the manufacturer. Dispose of used batteries according to the manufacturer’s instructions.	
Flash Disk	2 Megabytes
Memory	See Table 4-37 above.
PiCPro Port (to workstation)	RS232 serial port, secured protocol. Software selectable baud rate to 57.6K
User Port (to serial interface device)	RS232/RS485 serial port Supports RTS/CTS hardware handshaking Software selectable baud rate to 19.2K
Input voltage	20 VDC to 30 VDC
Input power	MMC: 250 mA plus I/O & Expansion Module power MMC Plus: 450mA plus I/O & Expansion Module power 10 A max

Time-of-day clock Clock tolerance	Access via PiCPro 10.2 and above or your application program At 25°C (77°F), ±1 second per day Over temperature, voltage and aging variation, +2/-12 seconds per day
Operating temperature range	5°C to 55°C (41°F to 131°F)
Storage temperature range	-40°C to 85°C (-40°F to 185°F)
Humidity	5 to 95%, non-condensing
CE Marked	Conforms to Directives 73/23/EEC, 89/336/EEC, 92/31/EEC, 93/68/EEC by conforming to the following standards: EN 50081-2:1993 EMC Generic Industrial Emissions EN 50082-2:1995 EMC Generic Industrial Immunity EN 61131-2:1994/A11:1996 Low voltage directive requirements for programmable controllers Operates with emissions below EN55011/ CISPR 11 Class A limits Immune to: <ul style="list-style-type: none"> • Electrostatic discharge (4K V contact mode, 8K V air discharge) per EN61000-4-2 • RF electromagnetic fields per EN61000-4-3, ENV 50141, and ENV50204 • Electrical fast transients per EN61000-4-4 • Magnetic fields per EN61000-4-8 Refer to the EMC Guidelines for more information.
UL and C/UL Listed	E126417
Physical size	2.25" wide x 9.6" high x 5.3" deep 57.15 mm x 243.84 mm x 134.62 mm
Vibration (per IEC 68-2-6)	10-57 Hz (constant amplitude = .15 mm) 57 - 2000 Hz (acceleration = 2 g)
Shock (per IEC 68-2-27)	Four shocks per axis (15g/11 msec)
Axis Port Analog Output	
Output channels	2 or 4
Resolution	16 bits
Output voltage range	±10 VDC
Maximum output current (1K Ω load)	±10 mA
Power on output voltage	0 V ±100 mV
Scan loss output voltage	0V ±100 mV
Accuracy	±0.375% of FSR Drift ± 50ppm/°C
Update rate	68 μsec

Aux Port Analog Input	
Input channel	1
Resolution	12 bits
Input voltage range	± 10 V
Accuracy	$\pm 0.2\%$ of FSR
Sample rate	100 μ sec
Common mode filter	3 dB @ 10 K Hz
Differential mode filter	3 dB @ 475 Hz
Axis Port & Aux Port Encoder Input	
Input channels	3 or 5
Input receiver	26C32 differential RS422 receiver
Recommended Encoder Drivers	7272, 75183, 8830, 75114, 9614, 26LS31 (or equivalent)
Encoder signals	Differential quadrature
Input threshold	± 750 mV
Input termination	120 ohm, provided on board
Maximum input voltage	5 V
Maximum A or B input frequency	250 K Hz (1 M feedback unit count rate)
Fast input voltage	Nominal 24 VDC, maximum 30 VDC
Guaranteed on voltage	15 VDC
Guaranteed off voltage	5 VDC
Turn on/off time	1 ms

Axis Port, Aux Port, and Gen I/O Port DC Inputs	
Configuration	The general inputs are divided into two groups of eight. Each group can be configured for sourcing or sinking. The auxiliary inputs are divided into two groups of six inputs. Each group can be configured for sourcing or sinking. The axis inputs have one input per axis. Each input can be configured for sourcing or sinking. Operates with IEC Type 1 inputs (per IEC 1131=2).
Input voltage	Nominal 24 VDC, maximum 30 VDC
Guaranteed on voltage	15 VDC
Guaranteed off voltage	5 VDC
Turn on/off time	1 ms
Fast inputs	50 μ sec
Gen I/O Port DC Outputs	
Number of outputs	16 outputs
Input voltage	Nominal 24 VDC, 30 VDC maximum
Configuration	Two groups of eight solid-state switches.
Protection of logic circuits	Optical isolation between the logic and field side, transient suppression on the 24V external supply
Maximum current	.25 A per output
Voltage range	24 VDC nominal, 5 to 30 VDC
Switch characteristics	Solid-state switches
Time delay on for resistive loads	50 μ sec max
Time delay off for resistive loads	50 μ sec max
Leakage current in off state	0.5 mA max
Switch voltage, maximum ON	1 VDC max
Short circuit protection for each group	15 A (max) pulses for about 130 μ sec every 100 msec until short is removed
Scan loss response	Outputs turn off

Axis Port DC Outputs	
Number of outputs	2 outputs per axis
Configuration	Each set of axis outputs can be configured as sourcing or sinking.
Maximum current	100 mA per output
Voltage range	24 VDC nominal, 5 to 30 VDC range
Scan loss response	Outputs turn off
Aux Port +5 Vdc Output	
+5 VDC	150 mA maximum current available. Connections to this point should be over short distances and away from electric noise signals.
SERCOS Motion Board	
SERCOS Interface	Interfaces with one ring (MMC-S8) or two rings (MMC-S16) with from one to eight Sercos drives per ring
SERCOS port	SMA female connectors for interfacing to 1000 μ meter plastic fiber optic cable with SMA male connectors. Fiber optic receiver specifications: Peak input power (optical level low) -31.2dBm max Peak input power (optical level high) -20.0 dBm min, 0.0dBm max Fiber optic transmitter specifications: Peak output power (optical level high) is -10.5 dBm min, -5.5 dBm max
Update loader port	RS232 interface
SERCOS Cable	
Type	Plastic with step index profile (POF)
Core diameter Fiber diameter	980 μ m \pm 60 μ m 1000 μ m \pm 60 μ m
Operating temperature	0° C to 55° C (32° F to 131° F)
Minimum bend radius	One time: 30 mm Continuous: 80 mm
Tensile strength	One time: 250 N Continuous: 100 N
Connectors	SMA style male

5 Standalone Digital MMC Control

5.1 Introduction

This section contains information for the Standalone Digital MMC Control (MMC-D32, -D64) only. Information on the Standalone MMC Control (MMC-A2, -A4, -S8, -S16) is contained in [section 4 on page 35](#), and information on the MMC-DSAXX Control (MMC-DSA2, -DSA4, -DSA8, -DSA16) is contained in [section 6 on page 119](#). Block I/O information can be found in the Block I/O Hardware Manual. Software information can be found in the PiCPro online help, the Function/Function Block Reference Guide, ASFB Manuals or on-line.

5.2 Features

- 400 Mhz Celeron Processor with 256 Kbytes of level 2 cache
- 3 Mbytes of Application Memory
- 960 Kbytes of RAMDISK Memory
- 192 Kbytes of Data Memory
- 100Base-T Ethernet port
- PicPro RS232 port, baud rates up to 115.2 Kbaud
- User RS232/RS485 port, RTS/CTS handshaking, baud rates up to 115.2 Kbaud
- Battery-backed time-of-day clock
- Application stored in battery-back RAM
- Block I/O port for I/O expansion
- Up to 4 MMC Option Modules can be user-installed
- 32 and 64 axis versions available
- PicPro USB high speed peripheral port (future)
- User USB high speed peripheral port (future)
- Compact Flash memory socket (future)
- UL Listed and CE Marked.

5.3 Overview

The Standalone Digital MMC-D64 Control can control up to 64 Digital MMC Smart Drives (32 drives on the -D32), providing 64 (32) axis of servo control. I/O can be added using Danaher Motion's serially distributed Block I/O Modules (covered in the Block I/O Modules Manual).

The PiCPro programming tool used with the PiC family of controls is also used to program the MMC.

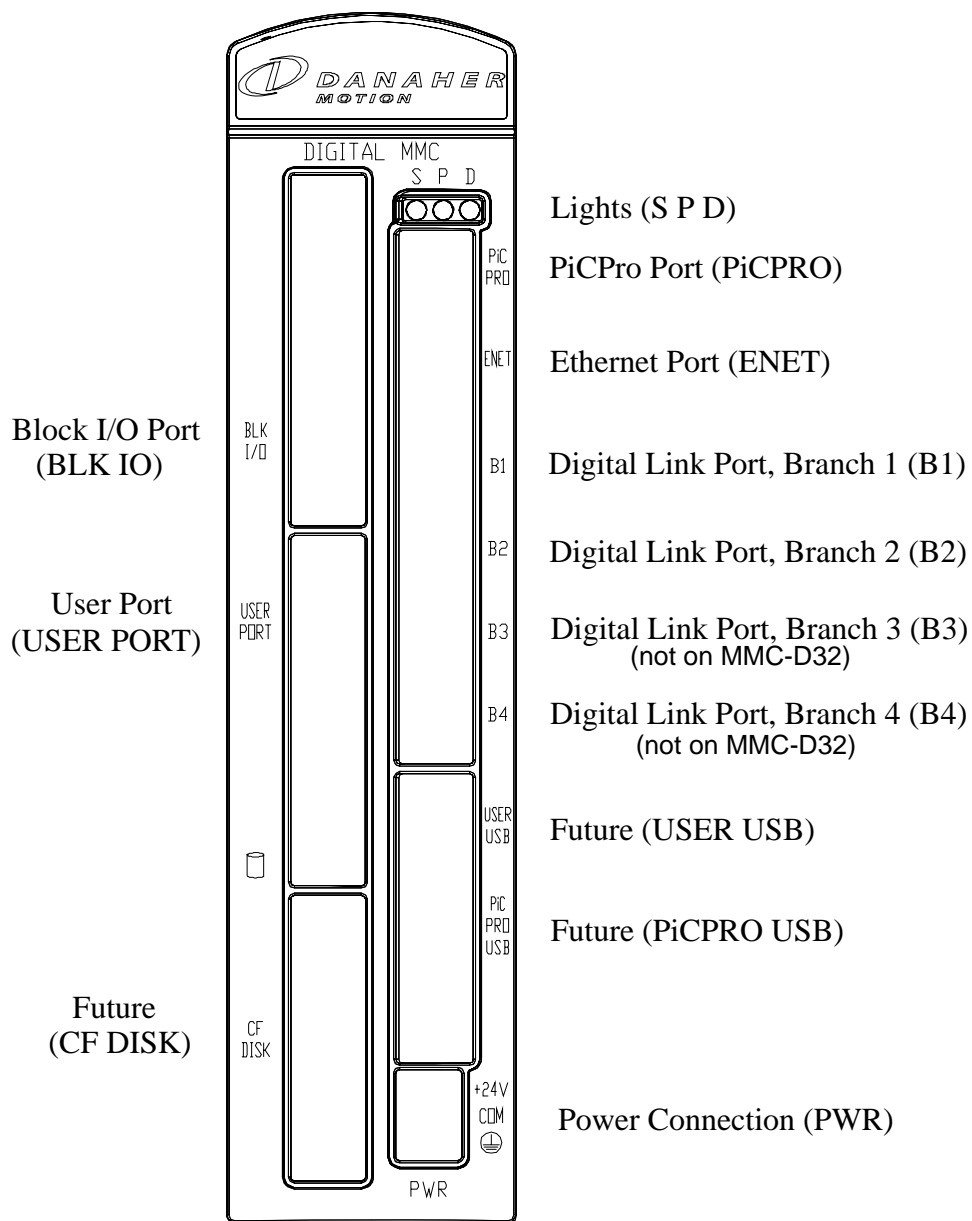
Up to four MMC Option Modules may be added to the Standalone Digital MMC Control.

The following is a list of available MMC Option Modules:

- MMC DeviceNet Option Module, see [section 8 on page 163](#).
- MMC Profibus Option Module, see [section 9 on page 169](#).
- MMC Axis I/O Option Module (limitations apply), see [section 10 on page 175](#).

- MMC 32 In/32 Out Option Module, see [section 11 on page 181](#).

Figure 5-1: Standalone Digital MMC Control



5.4 Power Supply Requirements

The Standalone Digital MMC Control is powered by user-supplied 24 Vdc (nominal). The maximum power consumption is 1A (24 W). Also, MMC Option Modules attached to the Standalone Digital MMC Control draw power from the Control's 24 Vdc connector. When determining the size of the 24 Vdc power supply, use the worksheet found in [Table 5-1](#).

Table 5-1: Power Supply Worksheet			
MMC Module	Current (mA)	# of Units	Subtotal (mA)
64 Axis Standalone Digital MMC Control (-D64)	1,000		
32 Axis Standalone Digital MMC Control (-D32)	900		
Axis I/O Option Module	100		
MMC Ethernet Option Module	200		
MMC DeviceNet Option Module	100		
MMC Profibus Option Module	100		
MMC 32 In/32 Out Option Module	100		
Required power supply current			

5.5 Connectors & Operation

This section provides theory-of-operation and connection information for the Standalone Digital MMC Control. See [Figure 5-1](#) for connector locations.

The Standalone Digital MMC Control converts +24 Vdc input power to various DC voltage levels that power the logic side of the Control. This same 24 Vdc power is also routed to any MMC Option Modules that may be connected to the Control.

Three lights on the front of the Control (Scan, Power, and Diagnostic) provide operational and diagnostic information, as described in [section 3.8 on page 31](#).

The Control does the following after +24 Vdc input power is applied:

- Performs diagnostic tests.
- Checks the battery.
- Performs routine maintenance tasks.
- Executes the application program.
- Communicates with any attached MMC Option Modules.
- Communicates with any Block I/O connected to the Block I/O port.
- Communicates with workstation connected to the PiCPro port.
- Communicates with any serial device(s) connected to the User Port.
- Communicates with any device(s) connected to the Ethernet Port.
- Communicates with any Digital MMC Smart Drives that are connected to one of the four Digital Link branches.

The Standalone Digital MMC Control contains a Compact Flash socket that is accessible from the front of the control. In the future, the Compact Flash may be used to store application object code, application source code, user data, etc. As of this writing, the Compact Flash socket is not supported, and a Compact Flash device should never be installed into the socket.

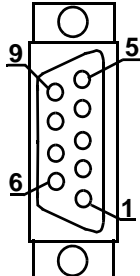
5.5.1 Block I/O Port

The 9-pin female D-sub PiCPro Port connector (labeled “BLK IO” on the front of the Control) provides serial communication between 1 to 77 Block I/O modules and the Control.

- Pin descriptions for are provided in [Table 5-2](#).
- Pin assignments are provided in [Table 5-3](#).
- The available Flying Lead cable is described in [Table 5-4](#).
- Connections to the Block I/O Module are described in [Table 5-5](#).
- Available Breakout Boxes and Cables are described in [Table 5-6](#).
- Breakout Box dimensions are shown in [Figure 5-2](#)

Table 5-2: Block I/O Port Pin Descriptions

Function	Notes	Pin
Transmit Data +	Transmits data to Block I/O Modules.	3
Transmit Data -	Transmits data to Block I/O Modules.	4
Receive Data +	Receives data from Block I/O Modules.	5
Receive Data -	Receives data from Block I/O Modules.	6
Shield Ground	Provides a path for shield current through the chassis to an external single point ground.	7 & Shell

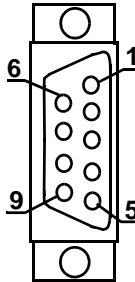
Table 5-3: Block I/O Port Pin Assignment			
Pin	Signal	In/Out	Connector Pinout
1	NC	N/A	9-pin female D-sub 
2	N/C	N/A	
3	Transmit Data +	Out	
4	Transmit Data -	Out	
5	Receive Data +	In	
6	Receive Data -	In	
7	Shield	In	
8	NC	N/A	
9	NC	N/A	
Connector Shell	Drain	In	

NOTE
Pin 7 of the Block I/O port connector is connected to the connector shell within the MMC. Therefore, the shield may be connected to either pin 7 or the connector shell.

Table 5-4: Block I/O Port to Flying Lead Cable

Part Number: M.1016.2568
 Length: 3 M (10 ft)
 Cable type: 24 AWG, twisted pair (individually shielded), 4 conductor.

9-Pin male D-sub (to Block I/O Port, face view)



Pin	Signal	Color	Notes
3	Transmit Data +	White	Twisted Pair with Shield
4	Transmit Data -	Black	
7	Shield	N/A	
5	Receive Data +	Red	Twisted Pair with Shield
6	Receive Data -	Black	
7	Shield	N/A	

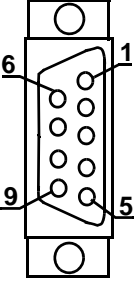
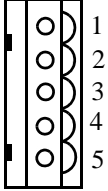
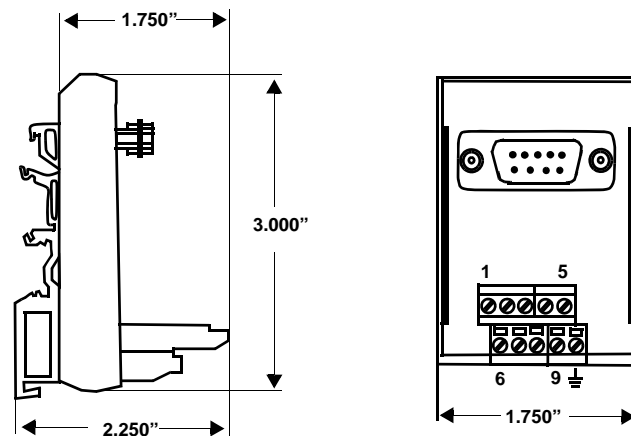
Table 5-5: Block I/O Port to Block I/O Module Wiring				
Use this table to wire from the Block I/O Port to the first Block I/O Module.				
9-Pin male D-sub (to Block I/O Port, face view) 		5-Pin Pluggable Screw Terminal (to Block I/O Module, face view) 		
Pin	Signal	Pin	Signal	Notes
3	Transmit Data +	1	Receive Data +	Twisted Pair
4	Transmit Data -	2	Received Data -	
5	Receive Data +	4	Transmit Data +	Twisted Pair
6	Received Data -	5	Transmit Data -	
7	Shield Ground	3	Shield Ground	
Shell	Drain	Shell	Drain	

Table 5-6: Block I/O Port Breakout Box and Cables ^a		
Description	Length	Part Number
MMC Block I/O Breakout Box	N/A	M.1016.2533
MMC Block I/O Connector to Breakout Box Cable	.3 M (1 ft)	M.1016.2543
MMC Block I/O Connector to Breakout Box Cable	.6 M (2 ft)	M.1016.2544
MMC Block I/O Connector to Breakout Box Cable	.9 M (3 ft)	M.1016.2545

a. The Breakout Box (see [Figure 5-2 on page 102](#)) is DIN-rail mounted, and provides screw terminal wire termination. It can be attached to the “BLK I/O” port on the MMC Control. The pinouts on the terminal strip interface provide a one-to-one transfer of the signals from the connector to the respective pin(s) on the terminal block. The connector pins marked with the “ground” symbol on the screw connector are connected to the “D” connector shell for shield grounding purposes.

Figure 5-2: Block I/O Breakout Box Dimensions



5.5.2 User Port

The 15-pin HD male D-sub User Port connector (labeled “USER PORT” on the front of the Control) provides RS232 and RS485 serial communication between a serial device and the Control

- Pin descriptions are provided in [Table 5-7](#)
- Pin assignments are provided in [Table 5-8](#)
- The available Flying Lead cable is described in [Table 5-9](#).
- The available RS-232 Exter HMI cable is described in [Table 5-10](#).
- The available RS-485 Exter HMI cable is described in [Table 5-11](#).
- Available Breakout Boxes and Cables are described in [Table 5-12](#).
- Breakout Box dimensions are shown in [Figure 5-3](#)

Table 5-7: User Port Pin Descriptions		
Function	Notes	Pin
RS232 Receive Data	RS232-level signal that receives serial data from the connected serial device.	9
RS232 Transmit Data	RS232-level signal that sends serial data to the connected serial device.	10
RS232 Request-to-send	RS232-level signal that indicates to the connected serial device that it can transmit data to the Control.	5
RS232 Clear-to-send	RS232-level signal that indicates to the Control that it can transmit data to the connected serial device.	7
RS-232 Data-terminal-ready	This output from the Control is always high (5 Vdc).	4
RS-485 Receive Data +	RS485-level signal that receives serial data from the connected serial device(s).	12
RS-485 Receive Data -	RS485-level signal that receives serial data from the connected serial device(s).	13
RS-485 Transmit Data +	RS485-level signal that transmits serial data to the connected serial device(s).	14
RS-485 Transmit Data -	RS485-level signal that transmits serial data to the connected serial device(s).	15
Signal Ground	Provides the return path for signals	8
Shield Ground	Provides a path for shield current through the chassis to an external single point ground.	Shell

Table 5-8: User Port Pin Assignments

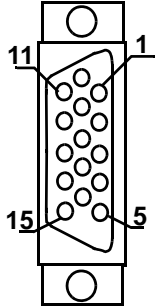
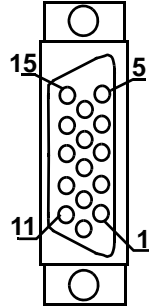
Pin	Signal	In/Out	Connector Pinout
1	NC	N/A	15-pin HD male D-sub 
2	N/C	N/A	
3	N/C	N/A	
4	RS232 Data-terminal-ready (5 Vdc)	Out	
5	RS232 Request-to-Send	Out	
6	N/C	N/A	
7	RS232 Clear- to-Send	In	
8	Signal Ground	In/Out	
9	RS232 Receive Data	In	
10	RS232 Transmit Data	Out	
11	N/C	N/A	
12	RS485 Receive Data +	In	
13	RS485 Receive Data -	In	
14	RS485 Transmit Data +	Out	
15	RS485 Transmit Data -	Out	
Connector Shell	Drain	In	

Table 5-9: User Port to Flying Lead Cable

Part Number: M.1016.2565
 Length: 3 M (10 ft)
 Cable type: 28 AWG, shielded, twisted pair, 16 conductor.

15-Pin HD female D-sub (to User Port, face view)

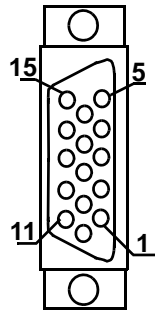


Pin	Signal	Color	Notes
3	N/C	Blue	Twisted
8	Signal Ground	Blue/Black	Pair
12	RS485 Receive Data +	Brown	Twisted
13	RS485 Receive Data -	Brown/Black	Pair
14	RS485 Transmit Data +	Violet	Twisted
15	RS485 Transmit Data -	Violet/Black	Pair
4	RS232 Data-terminal Ready	White	
5	RS232 Request-to-send	Red	
7	RS232 Clear-to-send	Green	
9	RS232 Receive Data	Yellow	
10	RS232 Transmit Data	Orange	
Shell	Drain	N/A	

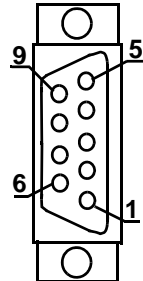
Table 5-10: User Port to RS-232 Exter HMI Cable

Part Number: M.1302.8453
 Length: 4 M (13 ft)
 Cable type: 24 AWG, shielded, twisted pair, 4 conductor.

15-Pin HD female D-sub
 (to User Port, face view)



9-Pin female D-sub (to
 Exter HMI COM2 Port,
 face view)

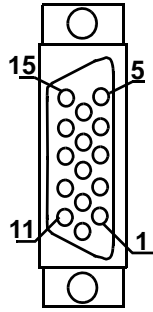


Pin	Signal	Pin	Signal	Notes
9	Receive Data	3	Transmit Data	Twisted Pair
10	Transmit Data	2	Receive Data	
8	Signal Ground	5	Signal Ground	
Shell	Drain	Shell	Drain	

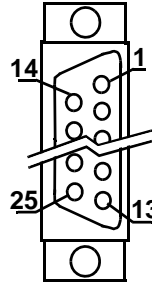
Table 5-11: User Port to RS-485 Exter HMI Cable

Part Number: M.1302.8454
 Length: 4 M (13 ft)
 Cable type: 24 AWG, shielded, twisted pair, 6 conductor.

15-Pin HD female D-sub
 (to User Port, face view)



25-Pin male D-sub (to
 Exter HMI COM1 Port,
 face view)

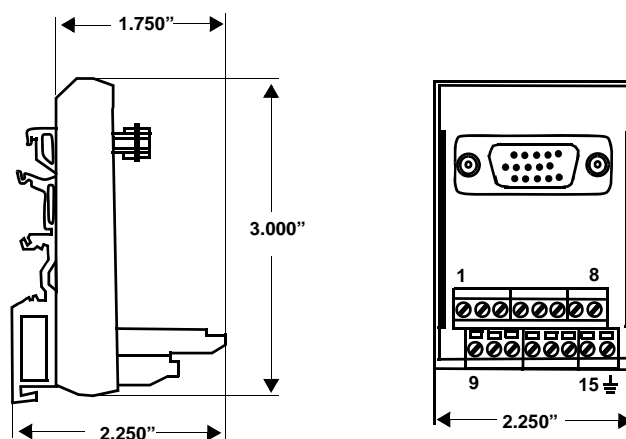


Pin	Signal	Pin	Signal	Notes
12	Receive Data+	2	Transmit Data+	Twisted Pair
13	Receive Data-	15	Transmit Data-	
14	Transmit Data+	3	Receive Data+	Twisted Pair
15	Transmit Data-	16	Receive Data-	
8	Signal Ground	7	Signal Ground	
Shell	Drain	Shell	Drain	

Description	Length	Part Number
MMC User Port Breakout Box	N/A	M.1016.2530
MMC User Port to Breakout Box Cable	.3 M (1 ft)	M.1016.2715
MMC User Port to Breakout Box Cable	.6 M (2 ft)	M.1016.2716
MMC User Port to Breakout Box Cable	.9 M (3 ft)	M.1016.2717

a. The Breakout Box (see [Figure 5-3 on page 108](#)) is DIN-rail mounted, and provides screw terminal wire termination. It can be attached to the “USER PORT” connector on the MMC Control. The pinouts on the terminal strip interface provide a one-to-one transfer of the signals from the connector to the respective pin(s) on the terminal block. The connector pins marked with the “ground” symbol on the screw connector are connected to the “D” connector shell for shield grounding purposes.

Figure 5-3: User Port Breakout Box Dimensions



5.5.3

PiCPro Port

The 6-pin circular DIN PiCPro Port connector (labeled “PiCPro” on the front of the Control) provides serial communication for the PiCPro programming interface.

- Pin descriptions for are provided in [Table 5-13](#)
- Pin assignments are provided in [Table 5-14](#)
- The available PiCPro Port to PC cable is described in [Table 5-15](#)

Table 5-13: PiCPro Port Pin Descriptions

Function	Notes	Pin
Receive Data	RS232-level signal that receives serial data from the connected PC running PiCPro.	1
Transmit Data	RS232-level signal that transmits serial data to the connected PC running PiCPro.	2
Signal Ground	Provides the return path for signals	3 and 5
Shield Ground	Provides a path for shield current through the chassis to an external single point ground.	Connector Shell

Table 5-14: PiCPro Port Pin Assignments

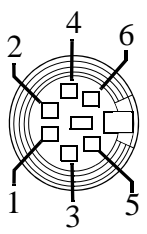
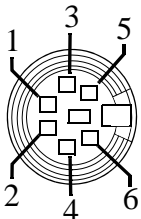
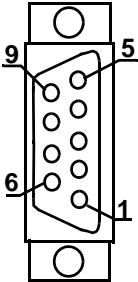
Pin	Signal	In/Out	Connector Pinout
1	RS232 Receive Data	In	6-pin Female Miniature Circular DIN 
2	RS232 Transmit Data	Out	
3	Signal Ground	In/Out	
4	NC	N/A	
5	Signal Ground	In/Out	
6	NC	N/A	
Connector Shield	Shield	In	

Table 5-15: PiCPr0 Port to PC Cable

Part Number: M.1302.8284 Length: 4 M (13 ft) Cable type: 24 AWG, shielded, twisted pair, 4 conductor.				
6-Pin male Miniature Circular DIN (to PiCPro Port, face view)		9-Pin female D-sub (to PC COM Port, face view)		
				
Pin	Signal	Pin	Signal	Notes
1	RS232 Receive Data	3	RS232 Transmit Data	Twisted Pair
2	RS232 Transmit Data	2	RS232 Receive Data	
5	Signal Ground	5	Signal Ground	
Shell	Drain	Shell	Drain	

5.5.4 Ethernet Port

The 8-pin RJ-45 Ethernet Port connector (labeled “ENET” on the front of the Control) provides IEEE 802.3/802.3u-100Base-TX/10Base T, half duplex connectivity between an Ethernet device and the Control. Also provided on the RJ-45 connector is a green “Link” light (which will be on if there is either a 100Base-T or 10Base-T Link) and a green “Activity” light (which will be on whenever a send or receive packet has occurred on the network).

Communication using the Ethernet Port can be between the Control and a PC, User Interface, or other Ethernet device or network. For example, PiCPro running on a PC can communicate to the Control through this Ethernet connector.

Typically, a “straight-through” shielded cable should be used when connecting the Control to another Ethernet device.

- Pin descriptions for are provided in [Table 5-16](#)
- Pin assignments are provided in [Table 5-17](#)
- The available Ethernet Port to Ethernet Device cables are described in [Table 5-18](#)

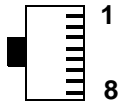

Table 5-16: Ethernet Port Pin Descriptions

Function	Notes	Pin
Receive Data +	Receives data from connected device.	3
Receive Data -	Receives data from connected device.	6
Transmit Data +	Transmits data to connected device.	1
Transmit Data -	Transmits data to connected device.	2
Shield Ground	Provides a path for shield current through the chassis to an external single point ground.	Shell

Table 5-17: Ethernet Port Pin Assignments

Pin	Signal	In/Out	Connector Pinout
1	Transmit Data +	Out	
2	Transmit Data -	Out	
3	Receive Data +	In	
4	Termination Resistors ^a	In	
5	Termination Resistors ^(a)	In	
6	Receive Data -	In	
7	Termination Resistors ^(a)	In	
8	Termination Resistors ^(a)	In	
Connector Shell	Shield	In	

a. Pins 4, 5, 7, and 8 are tied to termination resistors on the Control. Standard Ethernet cables contain 8 wires. The Control only uses 4 of these wires as shown. Connecting the 4 unused wires to pins 4, 5, 7, and 8, (as will be done in a standard Ethernet cable) reduces noise that can be induced from the unused wires to the Transmit and Receive wires.

Table 5-18: Ethernet Port to Ethernet Device Cables				
Part Numbers: .3 M (1.0 ft): M.1302.8285 .6 M (2.0 ft): M.1302.8286 1 M (3.3 ft): M.1302.8287 2 M (6.6 ft): M.1302.8288 3 M (9.8 ft): M.1302.8289 5 M (16.4 ft): M.1302.8300 10 M (32.8 ft): M.1302.8301 15 M (49.2 ft): M.1302.8302 30 M (98.4 ft): M.1302.8303 Cable type: 28 AWG, shielded, twisted pair, 8 conductor.				
8-Pin RJ-45 Plug (to Ethernet Port, face view) 		8-Pin RJ-45 Plug (to Ethernet Device, face view) 		
Pin	Signal	Pin	Signal	Notes
1	Transmit Data +	1	Receive Data +	Twisted Pair
2	Transmit Data -	2	Receive Data -	
3	Receive Data +	3	Transmit Data +	Twisted Pair
6	Receive Data -	6	Transmit Data -	
4	None	4	None	Twisted Pair
5	None	5	None	
7	None	7	None	Twisted Pair
8	None	8	None	
Shell	Drain	Shell	Drain	

5.5.5 Digital Link Ports

The four 8-pin RJ-45 Digital Link Port connectors (labeled “B1”, “B2”, “B3”, and “B4” on the front of the Control) provide communications between the Control and Digital MMC Smart Drives and/or S200-DLS Drives. Also provided on the RJ-45 connector is a green “Link” light (which will be on if there is a Drive connected to the branch) and a green “Activity” light (which will be on whenever a data packet is transmitted to the drive(s) on the branch).

Each of the four branches (two branches on the Digital MMC-D32) can control up to 16 drives. A “straight-through” shielded cable must be used when connecting the Control to the Digital Drive. Connect the cable from the Control to the Drives “IN” connector. Refer to the MMC Smart Drive manual for Drive information.

- Pin descriptions for are provided in [Table 5-19](#)

- Pin assignments are provided in [Table 5-20](#)
- The available Digital Link Port to Digital Drive cables are described in [Table 5-21](#)

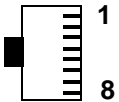
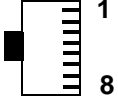
Table 5-19: Digital Link Port Pin Descriptions

Function	Notes	Pin
Receive Data +	Receives data from connected drives.	3
Receive Data -	Receives data from connected drives.	6
Transmit Data +	Transmits data to connected drives.	1
Transmit Data -	Transmits data to connected drives.	2
Shield Ground	Provides a path for shield current through the chassis to an external single point ground.	Shell

Table 5-20: Digital Link Port Pin Assignments

Pin	Signal	In/Out	Pin Sequence
1	Transmit Data +	Out	
2	Transmit Data -	Out	
3	Receive Data +	In	
4	Termination Resistors ^a	In	
5	Termination Resistors ^(a)	In	
6	Receive Data -	In	
7	Termination Resistors ^(a)	In	
8	Termination Resistors ^(a)	In	
Connector Shell	Shield	In	

a. Pins 4, 5, 7, and 8 are tied to termination resistors on the Control. Standard Ethernet cables contain 8 wires. The Control only uses 4 of these wires as shown. Connecting the 4 unused wires to the Control pins 4, 5, 7, and 8, (as will be done in a standard Ethernet cable) reduces noise that can be induced from the unused wires to the Transmit and Receive wires.

Table 5-21: Digital Link Port to Digital Drive Cables				
Part Numbers: .3 M (1.0 ft): M.1302.8285 .6 M (2.0 ft): M.1302.8286 1 M (3.3 ft): M.1302.8287 2 M (6.6 ft): M.1302.8288 3 M (9.8 ft): M.1302.8289 5 M (16.4 ft): M.1302.8300 10 M (32.8 ft): M.1302.8301 15 M (49.2 ft): M.1302.8302 30 M (98.4 ft): M.1302.8303 Cable type: 28 AWG, shielded, twisted pair, 8 conductor.				
8-Pin RJ-45 Plug (to Digital Link Port, face view) 		8-Pin RJ-45 Plug (to Digital Drive, face view) 		
Pin	Signal	Pin	Signal	Notes
1	Transmit Data +	1	Receive Data +	Twisted Pair
2	Transmit Data -	2	Receive Data -	
3	Receive Data +	3	Transmit Data +	Twisted Pair
6	Receive Data -	6	Transmit Data -	
4	None	4	None	Twisted Pair
5	None	5	None	
7	None	7	None	Twisted Pair
8	None	8	None	
Shell	Drain	Shell	Drain	

5.5.6 User USB Port

The User USB Port connector (labeled “USER USB” on the front of the Control) is for future use. Do not connect any cables or devices to this port.

5.5.7 PiCPro USB Port

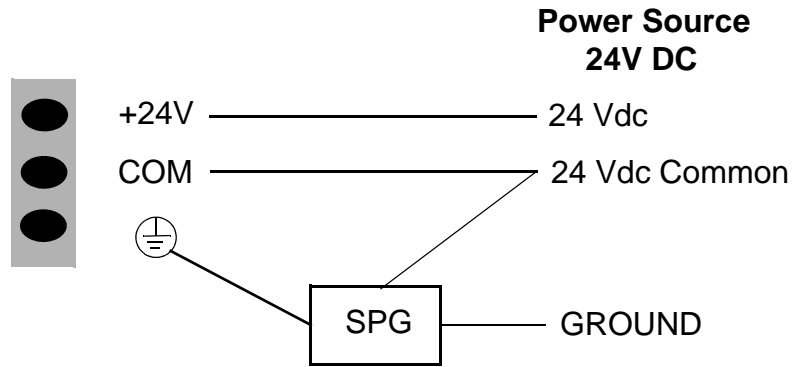
The PiCPro USB Port connector (labeled “PiCPro USB” on the front of the Control) is for future use. Do not connect any cables or devices to this port.

5.5.8 Power Connection

The Power connector (labeled “PWR” on the front of the Control) must be connected to a user-supplied +24 VDC power supply to provide power to the Standalone Digital MMC Control. This power supply also provides power to any attached MMC Option

modules. The power supply screw terminal connection (3 pin) is at the bottom of the Control. [Figure 5-4](#) illustrates the pin-out.

Figure 5-4: Pin Out for the 3-pin Power Supply Screw Terminal Connection



5.6 Specifications

		Number of servo axes available at indicated update rate ^a					
Model	Part Number	8 ms	4 ms	2 ms	1 ms	.5 ms	.25 ms
MMC-D32	M.1302.5109	32	32	32	32	24	8
MMC-D64	M.1302.5110	64	64	64	45	24	8

a. Using features such as servo tasks, S-curve, RATIO_RL, M_LINCIR, M_SCRVLC, PLS, and CAM_OUT places a heavier burden on available CPU time. Consult Danaher Motion for assistance if you want to exceed the number of axes in this chart.

Physical size	2.25" wide x 9.6" high x 5.3" deep 57.15 mm x 243.84 mm x 134.62 mm
CPU	400 Mhz Celeron ULV processor with numeric coprocessor
Battery	3V Coin Cell, BR3032 lithium battery
Battery Life	2 power-off years, minimum
CAUTION for Lithium Batteries Danger of explosion if battery is incorrectly replaced. Replace only with the same or equivalent type recommended by the manufacturer. Dispose of used batteries according to the manufacturer's instructions.	
Input voltage	20 VDC to 30 VDC (24 Vdc nominal)
Input power	1 A, maximum
Application Memory	3 Mbytes
RAMDISK Memory	960 Kbytes
Data Memory	192 Kbytes
Flash Disk	Future
PiCPro Port (to workstation)	RS232 serial port, secured protocol Software selectable baud rate to 115.2 Kbaud
User Port (to serial interface device)	RS232/RS485 serial port Supports RTS/CTS hardware handshaking Software selectable baud rate to 115.2 Kbaud

Ethernet Port (to Ethernet Device)	IEEE 802.3/802.3u-100Base-TX/10Base T Half duplex Cable type: Shielded, Straight Pinned, CAT5 or better (CAT5e, CAT6, etc.) Maximum cable length: 50 M (164 ft)
Block I/O Port (to Block I/O Modules)	1 to 77 Block I/O Modules may be connected. Maximum cable length: 61 M (200 ft)
Digital Link Ports (to Digital MMC Smart Drive)	IEEE 802.3/802.3u-100Base-TX Cable type: Shielded, Straight Pinned, CAT5 or better (CAT5e, CAT6, etc.) Maximum cable length: 30 M (98.4 ft)
Time-of-day clock Clock tolerance	Access via PiCPro 16.0 and above or your application program At 25°C (77°F), ±1 second per day Over temperature, voltage and aging variation, +2/-12 seconds per day
Operating temperature range	5°C to 55°C (41°F to 131°F)
Storage temperature range	-40°C to 85°C (-40°F to 185°F)
Humidity	5 to 95%, non-condensing
CE Marked	Conforms to Directives 73/23/EEC, 89/336/EEC, 92/31/EEC, 93/68/EEC by conforming to the following standards: EN 50081-2:1993 EMC Generic Industrial Emissions EN 50082-2:1995 EMC Generic Industrial Immunity EN 61131-2:1994/A11:1996 Low voltage directive requirements for programmable controllers Operates with emissions below EN55011/ CISPR 11 Class A limits Immune to: <ul style="list-style-type: none"> • Electrostatic discharge (4K V contact mode, 8K V air discharge) per EN61000-4-2 • RF electromagnetic fields per EN61000-4-3, ENV 50141, and ENV50204 • Electrical fast transients per EN61000-4-4 • Magnetic fields per EN61000-4-8 Refer to the EMC Guidelines for more information.
UL and C/UL Listed	E126417
Vibration (per IEC 68-2-6)	10-57 Hz (constant amplitude = .15 mm) 57 - 2000 Hz (acceleration = 2 g)
Shock (per IEC 68-2-27)	Four shocks per axis (15g/11 msec)

6 MMC-DSAXX Control

6.1 Introduction

This section contains information for the MMC-DSAXX Control (MMC-DSA2, -DSA4, -DSA8, -DSA16) only. Information on the Standalone MMC Control (MMC-A2, -A4, -S8, -S16) is contained in [section 4 on page 35](#), and information on the Standalone Digital MMC Control (MMC-D32, -D64) is contained in [section 5 on page 95](#). Block I/O information can be found in the Block I/O Modules Manual. Software information can be found in the PiCPro Online Help, the Function/Function Block Reference Guide, ASFB Manuals or on-line.

6.2 Features

- 32-bit RISC Processor
- 2 Mbytes of flash memory
- 384 Kbytes of Application Memory
- 256 Kbytes of User RAM Memory
- PicPro RS232 port, baud rates up to 57.6 Kbaud
- User RS232/RS485 port, RTS/CTS handshaking, baud rates up to 19.2 Kbaud
- Battery-backed time-of-day clock
- Application stored in battery-back RAM
- Block I/O port for I/O expansion
- Up to 4 MMC Option Modules can be user-installed
- Two, four, eight 16 axis versions available
- UL Listed and CE Marked.

6.3 Overview

The MMC-DSAXX Control offers a complete solution to both machine and motion control in a panel-mounted module. One MMC-DSAXX Control can control from 1 to 16 Digital Link enabled drives (230V Smart Drive, 460V Smart Drive, and S200-DLS Drive) as follows:

- Digital MMC- D2 (controls two Drive)
- Digital MMC- D4 (controls four Drive)
- Digital MMC- D8 (controls eight Drive)
- Digital MMC- D16 (controls 16 Drive)

PiCPro is used to program the MMC-DSAXX Control. The built-in I/O (eight 24VDC inputs and seven 24VDC outputs) can be expanded using Danaher Motion serially distributed block I/O (not included on the Digital MMC-D1).

Up to four MMC Option Modules may be added to the MMC-DSAXX Control.

The following is a list of available MMC Option Modules:

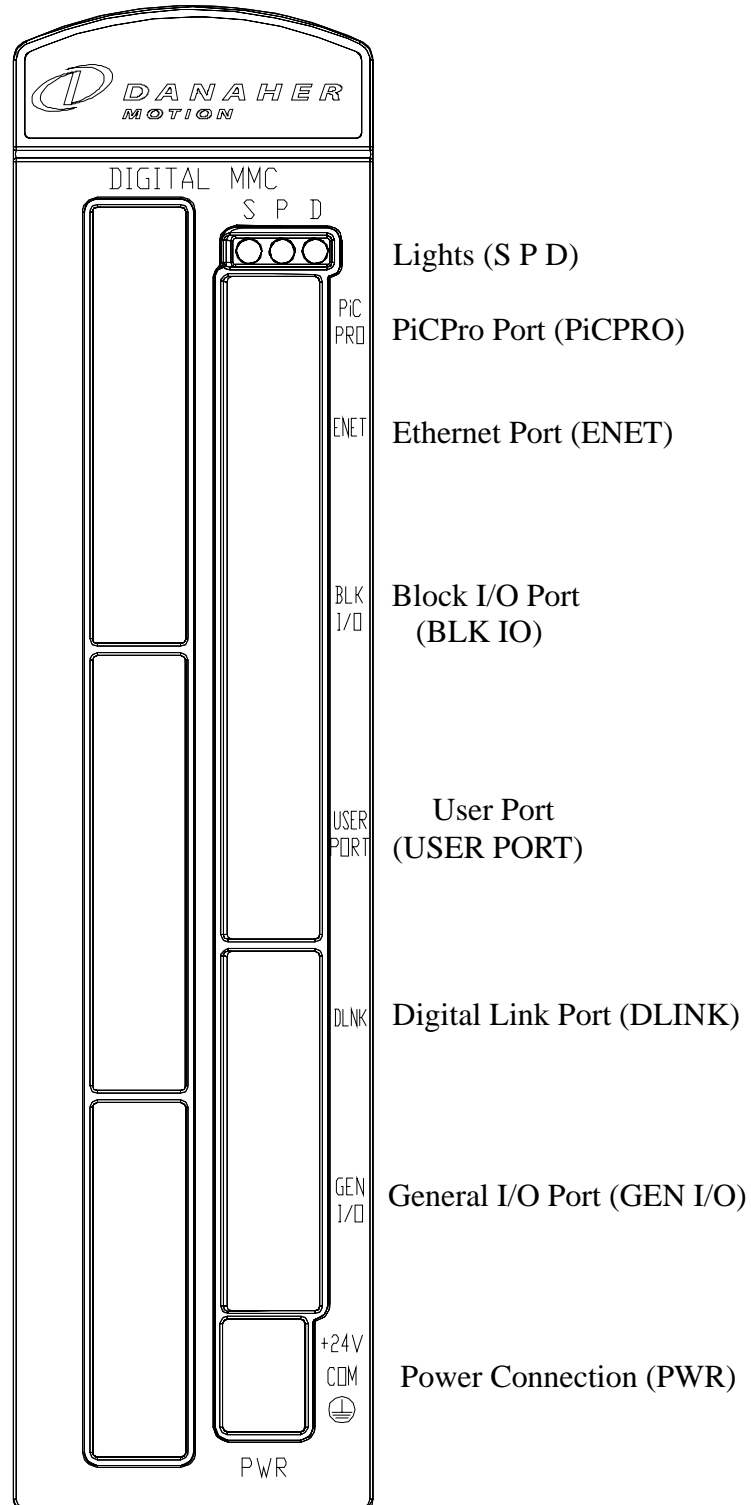
- MMC DeviceNet Option Module, see [section 8 on page 163](#).
- MMC Profibus Option Module, see [section 9 on page 169](#).
- MMC Axis I/O Option Module (limitations apply), see [section 10 on page 175](#).

- MMC 32 In/32 Out Option Module, see [section 11 on page 181](#).

6.3.1 Major Components

The MMC-DSAXX Control contains the CPU, a User Serial port, a Block I/O port, an Ethernet port, a Digital Link port, and a General I/O port consisting of eight DC inputs and seven DC outputs.

Figure 6-1: The MMC-DSAXX Control



6.4 Power Supply Requirements

The MMC-DSAXX Control is powered by user-supplied 24 Vdc (nominal). The maximum power consumption is 1A (24 W). Also, MMC Option Modules attached to the MMC-DSAXX Control draw power from the Control's 24 Vdc connector. When determining the size of the 24 Vdc power supply, use the worksheet found in [Table 6-1](#).

Table 6-1: Power Supply Worksheet			
MMC Module	Current (mA)	# of Units	Subtotal (mA)
MMC-DSAXX Control	250		
Total MMC-DSXX DCOUT current ^a			
Axis I/O Option Module	100		
MMC Ethernet Option Module	200		
MMC DeviceNet Option Module	100		
MMC Profibus Option Module	100		
MMC 32 In/32 Out Option Module	100		
Required power supply current			

a. The MMC-DSAXX Control DCOUT current is the maximum simultaneous current being driven out of Outputs 1 through 7. This will depend on the number and loading of each DC Output.

6.5 Connectors & Operation

This section provides theory-of-operation and connection information for the MMC-DSAXX Control. See [Figure 6-1 on page 121](#) for connector locations.

The MMC-DSAXX Control converts +24 Vdc input power to various DC voltage levels that power the logic side of the Control. This same 24 Vdc also power the 24 Vdc Outputs, and is also routed to any MMC Option Modules that may be connected to the Control.

Three lights on the front of the Control (Scan, Power, and Diagnostic) provide operational and diagnostic information, as described in [section 3.8 on page 31](#).

The Control does the following after +24 Vdc input power is applied:

- Performs diagnostic tests.
- Checks the battery.
- Performs routine maintenance tasks.
- Executes the application program.
- Communicates with any attached MMC Option Modules.
- Communicates with any Block I/O connected to the Block I/O port.

- Communicates with workstation connected to the PiCPro port.
- Communicates with any serial device(s) connected to the User Port.
- Communicates with any device(s) connected to the Ethernet Port.
- Communicates with any Digital MMC Smart Drives that are connected to the Digital Link Port.

6.5.1 PiCPro Port

The 6-pin circular DIN PiCPro Port connector (labeled “PiCPro” on the front of the Control) provides serial communication for the PiCPro programming interface.

- Pin descriptions for are provided in [Table 6-2](#)
- Pin assignments are provided in [Table 6-3](#)
- The available PiCPro Port to PC cable is described in [Table 6-4](#)

Table 6-2: PiCPro Port Pin Descriptions		
Function	Notes	Pin
Receive Data	RS232-level signal that receives serial data from the connected PC running PiCPro.	1
Transmit Data	RS232-level signal that transmits serial data to the connected PC running PiCPro.	2
Signal Ground	Provides the return path for signals	3 and 5
Shield Ground	Provides a path for shield current through the chassis to an external single point ground.	Connector Shell

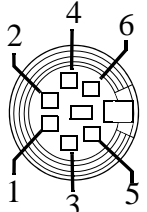
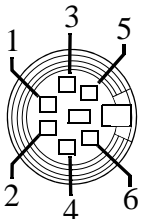
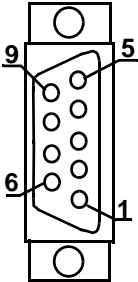
Table 6-3: PiCPro Port Pin Assignments			
Pin	Signal	In/Out	Connector Pinout
1	RS232 Receive Data	In	6-pin Female Miniature Circular DIN (face view) 
2	RS232 Transmit Data	Out	
3	Signal Ground	In/Out	
4	NC	N/A	
5	Signal Ground	In/Out	
6	NC	N/A	
Connector Shield	Shield	In	

Table 6-4: PiCPr0 Port to PC Cable

Part Number: M.1302.8284 Length: 4 M (13 ft) Cable type: 24 AWG, shielded, twisted pair, 4 conductor.				
6-Pin male Miniature Circular DIN (to PiCPro Port, face view)		9-Pin female D-sub (to PC COM Port, face view)		
				
Pin	Signal	Pin	Signal	Notes
1	RS232 Receive Data	3	RS232 Transmit Data	Twisted
2	RS232 Transmit Data	2	RS232 Receive Data	Pair
5	Signal Ground	5	Signal Ground	
Shell	Drain	Shell	Drain	

6.5.2 Ethernet Port

The 8-pin RJ-45 Ethernet Port connector (labeled “ENET” on the front of the Control) provides IEEE 802.3/802.3u-100Base-TX/10Base T, half duplex connectivity between an Ethernet device and the Control. Also provided on the RJ-45 connector is a green “Link” light (which will be on if there is either a 100Base-T or 10Base-T Link) and a green “Activity” light (which will be on whenever a send or receive packet has occurred on the network).

Communication using the Ethernet Port can be between the Control and a PC, User Interface, or other Ethernet device or network. For example, PiCPro running on a PC can communicate to the Control through this Ethernet connector.

Typically, a “straight-through” shielded cable should be used when connecting the Control to another Ethernet device.

- Pin descriptions for are provided in [Table 6-5](#)
- Pin assignments are provided in [Table 6-6](#)
- The available Ethernet Port to Ethernet Device cables are described in [Table 6-7](#)

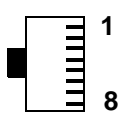
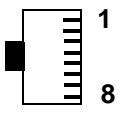
Table 6-5: Ethernet Port Pin Descriptions

Function	Notes	Pin
Receive Data +	Receives data from connected device.	3
Receive Data -	Receives data from connected device.	6
Transmit Data +	Transmits data to connected device.	1
Transmit Data -	Transmits data to connected device.	2
Shield Ground	Provides a path for shield current through the chassis to an external single point ground.	Shell

Table 6-6: Ethernet Port Pin Assignments

Pin	Signal	In/Out	Connector Pinout
1	Transmit Data +	Out	
2	Transmit Data -	Out	
3	Receive Data +	In	
4	Termination Resistors ^a	In	
5	Termination Resistors ^(a)	In	
6	Receive Data -	In	
7	Termination Resistors ^(a)	In	
8	Termination Resistors ^(a)	In	
Connector Shell	Shield	In	

a. Pins 4, 5, 7, and 8 are tied to termination resistors on the Control. Standard Ethernet cables contain 8 wires. The Control only uses 4 of these wires as shown. Connecting the 4 unused wires to pins 4, 5, 7, and 8, (as will be done in a standard Ethernet cable) reduces noise that can be induced from the unused wires to the Transmit and Receive wires.

Table 6-7: Ethernet Port to Ethernet Device Cables				
Part Numbers: .3 M (1.0 ft): M.1302.8285 .6 M (2.0 ft): M.1302.8286 1 M (3.3 ft): M.1302.8287 2 M (6.6 ft): M.1302.8288 3 M (9.8 ft): M.1302.8289 5 M (16.4 ft): M.1302.8300 10 M (32.8 ft): M.1302.8301 15 M (49.2 ft): M.1302.8302 30 M (98.4 ft): M.1302.8303 Cable type: 28 AWG, shielded, twisted pair, 8 conductor.				
8-Pin RJ-45 Plug (to Ethernet Port, face view) 		8-Pin RJ-45 Plug (to Ethernet Device, face view) 		
Pin	Signal	Pin	Signal	Notes
1	Transmit Data +	1	Receive Data +	Twisted
2	Transmit Data -	2	Receive Data -	Pair
3	Receive Data +	3	Transmit Data +	Twisted
6	Receive Data -	6	Transmit Data -	Pair
4	None	4	None	Twisted
5	None	5	None	Pair
7	None	7	None	Twisted
8	None	8	None	Pair
Shell	Drain	Shell	Drain	

6.5.3 Block I/O Port (C1)

The 9-pin female D-sub PiCPro Port connector (labeled “BLK I/O” on the front of the Control) provides serial communication between 1 to 77 Block I/O modules and the Control. Cables connecting the Control to the first Block I/O Module and between Block I/O modules can be up to 200 feet in length.

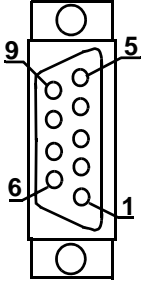
- Pin descriptions for are provided in [Table 6-8](#).
- Pin assignments are provided in [Table 6-9](#).
- The available Flying Lead cable is described in [Table 6-10](#).
- Connections to the Block I/O Module are described in [Table 6-11](#).
- Available Breakout Boxes and Cables are described in [Table 6-12](#).

- Breakout Box dimensions are shown in [Figure 6-2](#)

Table 6-8: Block I/O Port Pin Descriptions

Function	Notes	Pin
Transmit Data +	Transmits data to Block I/O Modules.	3
Transmit Data -	Transmits data to Block I/O Modules.	4
Receive Data +	Receives data from Block I/O Modules.	5
Receive Data -	Receives data from Block I/O Modules.	6
Shield Ground	Provides a path for shield current through the chassis to an external single point ground.	7 & Shell

Table 6-9: Block I/O Port Pin Assignment

Pin	Signal	In/Out	Connector Pinout
1	NC	N/A	9-pin female D-sub (face view) 
2	N/C	N/A	
3	Transmit Data +	Out	
4	Transmit Data -	Out	
5	Receive Data +	In	
6	Receive Data -	In	
7	Shield	In	
8	NC	N/A	
9	NC	N/A	
Connector Shell	Drain	In	

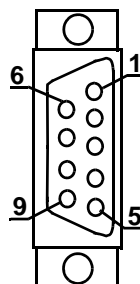
NOTE

Pin 7 of the Block I/O port connector is connected to the connector shell within the MMC. Therefore, the shield may be connected to either pin 7 or the connector shell.

Table 6-10: Block I/O Port to Flying Lead Cable

Part Number: M.1016.2568
 Length: 3 M (10 ft)
 Cable type: 24 AWG, twisted pair (individually shielded), 4 conductor.

9-Pin male D-sub (to Block I/O Port, face view)



Pin	Signal	Color	Notes
3	Transmit Data +	White	Twisted
4	Transmit Data -	Black	Pair
7	Shield	N/A	with Shield
5	Receive Data +	Red	Twisted
6	Receive Data -	Black	Pair
7	Shield	N/A	with Shield

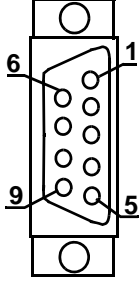
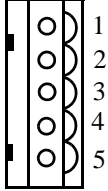
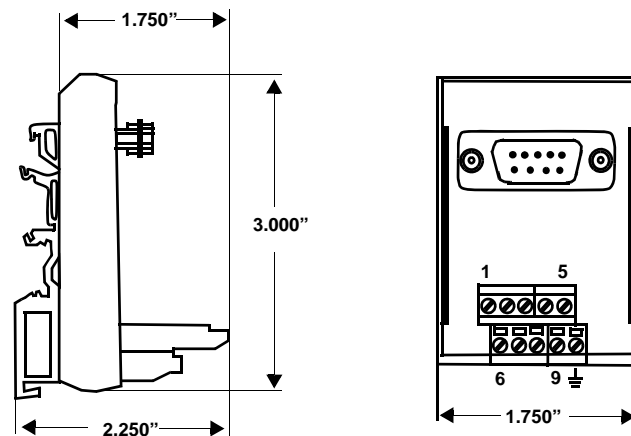
Table 6-11: Block I/O Port to Block I/O Module Wiring				
Use this table to wire from the Block I/O Port to the first Block I/O Module.				
9-Pin male D-sub (to Block I/O Port, face view) 		5-Pin Pluggable Screw Terminal (to Block I/O Module, face view) 		
Pin	Signal	Pin	Signal	Notes
3	Transmit Data +	1	Receive Data +	Twisted Pair
4	Transmit Data -	2	Received Data -	
5	Receive Data +	4	Transmit Data +	Twisted Pair
6	Received Data -	5	Transmit Data -	
7	Shield Ground	3	Shield Ground	
Shell	Drain	Shell	Drain	

Table 6-12: Block I/O Port Breakout Box and Cables ^a		
Description	Length	Part Number
MMC Block I/O Breakout Box	N/A	M.1016.2533
MMC Block I/O Connector to Breakout Box Cable	.3 M (1 ft)	M.1016.2543
MMC Block I/O Connector to Breakout Box Cable	.6 M (2 ft)	M.1016.2544
MMC Block I/O Connector to Breakout Box Cable	.9 M (3 ft)	M.1016.2545

a. The Breakout Box (see [Figure 6-2 on page 130](#)) is DIN-rail mounted, and provides screw terminal wire termination. The pinouts on the terminal strip interface provide a one-to-one transfer of the signals from the connector to the respective pin(s) on the terminal block. The connector pins marked with the “ground” symbol on the screw connector are connected to the “D” connector shell for shield grounding purposes.

Figure 6-2: Block I/O Breakout Box Dimensions

6.5.4 User Port

The 15-pin HD male D-sub User Port connector (labeled "USER PORT" on the front of the Control) provides RS232 and RS485 serial communication between a serial device and the Control. The User Port provides RS232/RS485 communications at Baud rates to 115.2 K with Multidrop capability.

- Pin descriptions are provided in [Table 6-13](#)
- Pin assignments are provided in [Table 6-14](#)
- The available Flying Lead cable is described in [Table 6-15](#).
- The available RS-232 Exter HMI cable is described in [Table 6-16](#).
- The available RS-485 Exter HMI cable is described in [Table 6-17](#).
- Available Breakout Boxes and Cables are described in [Table 6-18](#).
- Breakout Box dimensions are shown in [Figure 6-3](#)

Function	Notes	Pin
RS232 Receive Data	RS232-level signal that receives serial data from the connected serial device.	9
RS232 Transmit Data	RS232-level signal that sends serial data to the connected serial device.	10
RS232 Request-to-send	RS232-level signal that indicates to the connected serial device that it can transmit data to the Control.	5
RS232 Clear-to-send	RS232-level signal that indicates to the Control that it can transmit data to the connected serial device.	7
RS-232 Data-terminal-ready	This output from the Control is always high (12 Vdc).	4
RS-485 Receive Data +	RS485-level signal that receives serial data from the connected serial device(s).	12
RS-485 Receive Data -	RS485-level signal that receives serial data from the connected serial device(s).	13
RS-485 Transmit Data +	RS485-level signal that transmits serial data to the connected serial device(s).	14
RS-485 Transmit Data -	RS485-level signal that transmits serial data to the connected serial device(s).	15
Signal Ground	Provides the return path for signals	8
Shield Ground	Provides a path for shield current through the chassis to an external single point ground.	Shell

Table 6-14: User Port Pin Assignments

Pin	Signal	In/Out	Connector Pinout
1	NC	N/A	15-pin HD male D-sub (face view)
2	N/C	N/A	
3	N/C	N/A	
4	RS232 Data-terminal-ready (12 Vdc)	Out	
5	RS232 Request-to-Send	Out	
6	N/C	N/A	
7	RS232 Clear- to-Send	In	
8	Signal Ground	In/Out	
9	RS232 Receive Data	In	
10	RS232 Transmit Data	Out	
11	N/C	N/A	
12	RS485 Receive Data +	In	
13	RS485 Receive Data -	In	
14	RS485 Transmit Data +	Out	
15	RS485 Transmit Data -	Out	
Connector Shell	Drain	In	

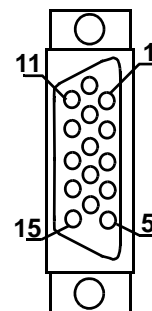
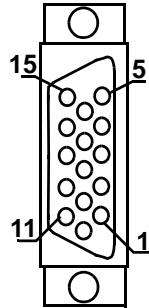


Table 6-15: User Port to Flying Lead Cable

Part Number: M.1016.2565
 Length: 3 M (10 ft)
 Cable type: 28 AWG, shielded, twisted pair, 16 conductor.

15-Pin HD female D-sub (to User Port, face view)

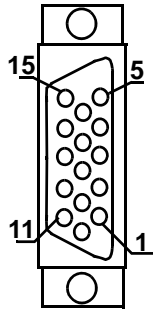


Pin	Signal	Color	Notes
3	N/C	Blue	Twisted Pair
8	Signal Ground	Blue/Black	
12	RS485 Receive Data +	Brown	Twisted Pair
13	RS485 Receive Data -	Brown/Black	
14	RS485 Transmit Data +	Violet	Twisted Pair
15	RS485 Transmit Data -	Violet/Black	
4	RS232 Data-terminal Ready	White	
5	RS232 Request-to-send	Red	
7	RS232 Clear-to-send	Green	
9	RS232 Receive Data	Yellow	
10	RS232 Transmit Data	Orange	
Shell	Drain	N/A	

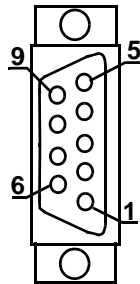
Table 6-16: User Port to RS-232 Exter HMI Cable

Part Number: M.1302.8453
 Length: 4 M (13 ft)
 Cable type: 24 AWG, shielded, twisted pair, 4 conductor.

15-Pin HD female D-sub
 (to User Port, face view)



9-Pin female D-sub (to
 Exter HMI COM2 Port,
 face view)



Pin	Signal	Pin	Signal	Notes
9	Receive Data	3	Transmit Data	Twisted Pair
10	Transmit Data	2	Receive Data	
8	Signal Ground	5	Signal Ground	
Shell	Drain	Shell	Drain	

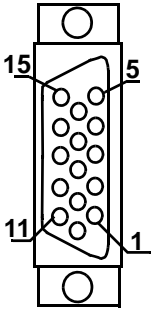
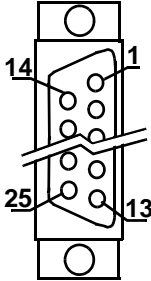
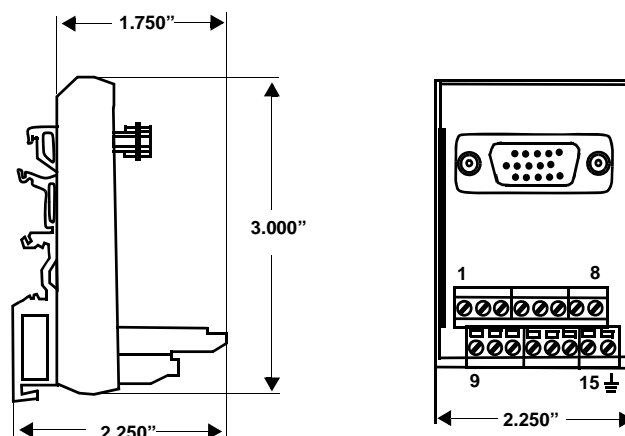
Table 6-17: User Port to RS-485 Exter HMI Cable				
Part Number: M.1302.8454 Length: 4 M (13 ft) Cable type: 24 AWG, shielded, twisted pair, 6 conductor.				
15-Pin HD female D-sub (to User Port, face view)		25-Pin male D-sub (to Exter HMI COM1 Port, face view)		
				
Pin	Signal	Pin	Signal	Notes
12	Receive Data+	2	Transmit Data+	Twisted
13	Receive Data-	15	Transmit Data-	Pair
14	Transmit Data+	3	Receive Data+	Twisted
15	Transmit Data-	16	Receive Data-	Pair
8	Signal Ground	7	Signal Ground	
Shell	Drain	Shell	Drain	

Table 6-18: User Port Breakout Box and Cables ^a		
Description	Length	Part Number
MMC User Port Breakout Box	N/A	M.1016.2530
MMC User Port to Breakout Box Cable	.3 M (1 ft)	M.1016.2715
MMC User Port to Breakout Box Cable	.6 M (2 ft)	M.1016.2716
MMC User Port to Breakout Box Cable	.9 M (3 ft)	M.1016.2717

a. The Breakout Box (see [Figure 6-3 on page 136](#)) is DIN-rail mounted, and provides screw terminal wire termination. Use one of the cables listed in the table to connect between the USER PORT connector and the Breakout Box. The pinouts on the terminal strip interface provide a one-to-one transfer of the signals from the connector to the respective pin(s) on the terminal block. The connector pins marked with the “ground” symbol on the screw connector are connected to the “D” connector shell for shield grounding purposes.

Figure 6-3: User Port Breakout Box Dimensions

6.5.5 Digital Link Port

The 8-pin RJ-45 Digital Link Port connector (labeled “DLINK” on the front of the Control) provide communications between Control and Digital MMC Smart Drives (and S200-DLS Drives). Also provided on the RJ-45 connector is a green “Link” light (which will be on if there is a Drive connected to the Digital Link Port).

The Control can be connected to either 2 (MMC-DSA2), 4 (MMC-DSA4), 8 (MMC-DSA8), or 16 (MMC-DSA8) Drives. A “straight-through” shielded cable must be used when connecting the Control to the Digital Drive. Connect the cable from the Control to the Drives “IN” connector. Refer to the MMC Smart Drive manual for Drive information.

- Pin descriptions for are provided in [Table 6-19](#)
- Pin assignments are provided in [Table 6-20](#)
- The available Digital Link Port to Digital Drive cables are described in [Table 6-21](#)

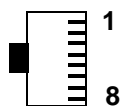
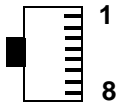
Table 6-19: Digital Link Port Pin Descriptions

Function	Notes	Pin
Receive Data +	Receives data from connected drives.	3
Receive Data -	Receives data from connected drives.	6
Transmit Data +	Transmits data to connected drives.	1
Transmit Data -	Transmits data to connected drives.	2
Shield Ground	Provides a path for shield current through the chassis to an external single point ground.	Shell

Table 6-20: Digital Link Port Pin Assignments			
Pin	Signal	In/Out	Pin Sequence
1	Transmit Data +	Out	
2	Transmit Data -	Out	
3	Receive Data +	In	
4	Termination Resistors ^a	In	
5	Termination Resistors ^(a)	In	
6	Receive Data -	In	
7	Termination Resistors ^(a)	In	
8	Termination Resistors ^(a)	In	
Connector Shell	Shield	In	

a. Pins 4, 5, 7, and 8 are tied to termination resistors on the Control. Standard Ethernet cables contain 8 wires. The Control only uses 4 of these wires as shown. Connecting the 4 unused wires to the Control pins 4, 5, 7, and 8, (as will be done in a standard Ethernet cable) reduces noise that can be induced from the unused wires to the Transmit and Receive wires.

Table 6-21: Digital Link Port to Digital Drive Cables

Table 6-21: Digital Link Port to Digital Drive Cables				
Part Numbers: .3 M (1.0 ft): M.1302.8285 .6 M (2.0 ft): M.1302.8286 1 M (3.3 ft): M.1302.8287 2 M (6.6 ft): M.1302.8288 3 M (9.8 ft): M.1302.8289 5 M (16.4 ft): M.1302.8300 10 M (32.8 ft): M.1302.8301 15 M (49.2 ft): M.1302.8302 30 M (98.4 ft): M.1302.8303 Cable type: 28 AWG, shielded, twisted pair, 8 conductor.				
8-Pin RJ-45 Plug (to Digital Link Port, face view) 		8-Pin RJ-45 Plug (to Digital Drive, face view) 		
Pin	Signal	Pin	Signal	Notes
1	Transmit Data +	1	Receive Data +	Twisted
2	Transmit Data -	2	Receive Data -	Pair
3	Receive Data +	3	Transmit Data +	Twisted
6	Receive Data -	6	Transmit Data -	Pair
4	None	4	None	Twisted
5	None	5	None	Pair
7	None	7	None	Twisted
8	None	8	None	Pair
Shell	Drain	Shell	Drain	

6.5.6 General I/O Port

The 15-pin HD female D-sub General I/O Port connector (labeled “GEN I/O” on the front of the Control) provides connection between user I/O devices and the Control. This port provides 7 source-only, 250ma, protected outputs (described in detail in [section 6.5.6.1 on page 143](#)), and 8 source-only inputs (described in detail in [section 6.5.6.2 on page 145](#)).

- Pin descriptions are provided in [Table 6-22](#)
- Pin assignments are provided in [Table 6-23](#)
- The available Flying Lead cable is described in [Table 6-24](#).
- Available Breakout Boxes and Cables are described in [Table 6-25](#).
- Breakout Box dimensions are shown in [Figure 6-4](#)

Function	Notes	Pin
DC Outputs 1-7	Nominal 24 Vdc Outputs capable of sourcing up to 250 ma.	1-7
DC Inputs 1-8	Nominal 24 Vdc sourcing Inputs	8-15
Shield Ground	Provides a path for shield current through the chassis to an external single point ground.	Shell

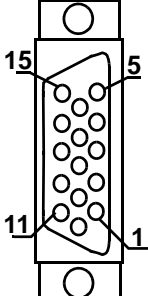
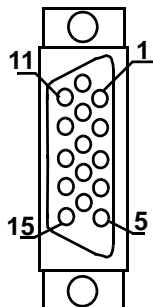
Pin	Signal	In/Out	Connector Pinout
1	DCOUT1	Out	<p>15-pin HD female D-sub (face view)</p> 
2	DCOUT2	Out	
3	DCOUT3	Out	
4	DCOUT4	Out	
5	DCOUT5	Out	
6	DCOUT6	Out	
7	DCOUT7	Out	
8	DCIN1	In	
9	DCIN2	In	
10	DCIN3	In	
11	DCIN4	In	
12	DCIN5	In	
13	DCIN6	In	
14	DCIN7	In	
15	DCIN8	In	
Shell	Drain	In	

Table 6-24: General I/O Port to Flying Lead Cable

Part Number: M.1016.2519
 Length: 3 M (10 ft)
 Cable type: 28 AWG, shielded, twisted pair, 16 conductor.

15-Pin HD male D-sub (to General I/O Port, face view)

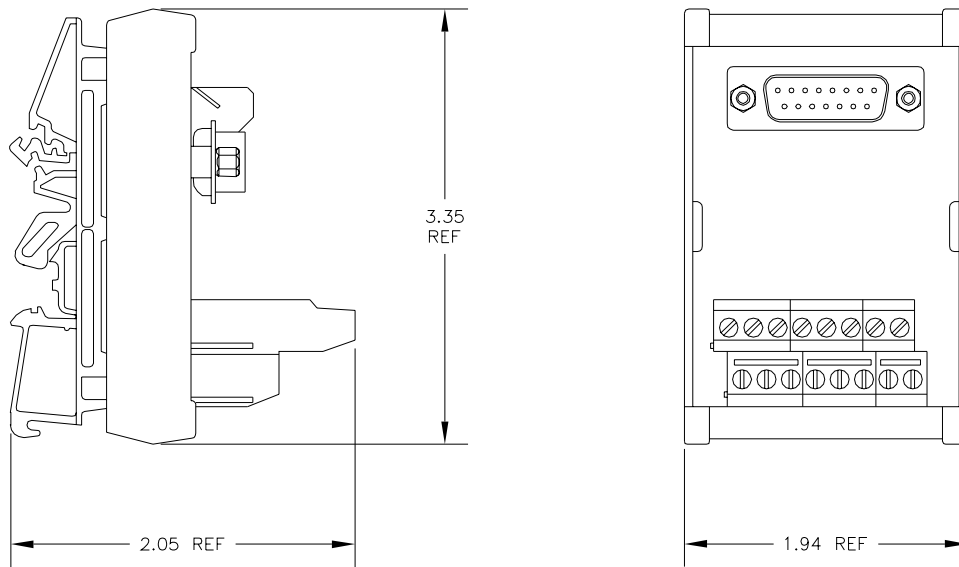


Pin	Signal	Color	Notes
1	DCOUT1	Blue	Twisted
2	DCOUT2	White/Blue	Pair
3	DCOUT3	Black	Twisted
4	DCOUT4	White/Black	Pair
5	DCOUT5	Red	Twisted
10	DCIN3	White/Red	Pair
8	DCIN1	Green	Twisted
9	DCIN2	White/Green	Pair
6	DCOUT6	Yellow	Twisted
7	DCOUT7	White/Yellow	Pair
11	DCIN4	Orange	Twisted
11	DCIN4	White/Orange	Pair
12	DCIN5	Brown	Twisted
13	DCIN6	White/Brown	Pair
14	DCIN7	Violet	Twisted
15	DCIN8	White/Violet	Pair
Shell	Drain	N/A	

Description	Length	Part Number
General I/O Port Breakout Board ^a	N/A	M.1302.6970
General I/O Port Breakout Box ^b	N/A	M.1302.6972
General I/O to Breakout Box Cable	1 M (3.3 ft)	M.1302.6976
	3 M (9.8 ft)	M.1302.6977
	9 M (29.5 ft)	M.1302.6979
	15 M (49.2 ft)	M.1302.6980
General I/O Breakout Box and Cable Kits. ^c	1 M (3.3 ft)	M.1302.7005
	3 M (9.8 ft)	M.1302.7006
	9 M (29.5 ft)	M.1302.7007
	15 M (49.2 ft)	M.1302.7008

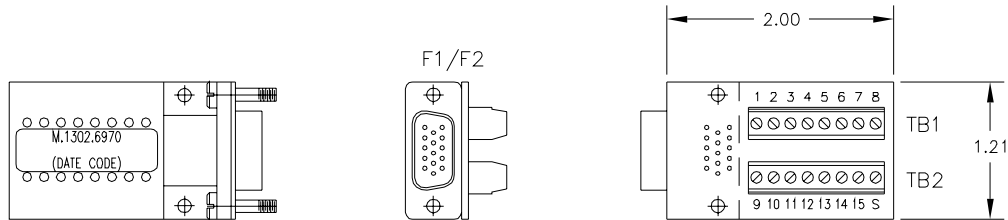
- a. The Breakout Board (see [Figure 6-5 on page 143](#)) is mounted directly to the GEN I/O connector, and provides screw terminals wire termination.
- b. The Breakout Box (see [Figure 6-4 on page 142](#)) is DIN-rail mounted, and provides screw terminal wire termination. Use one of the cables listed in the table to connect between the GEN I/O connector and the Breakout Box.
- c. These kits include an M.1302.6972 Breakout Box and an interconnect cable of the indicated length

Figure 6-4: General I/O Breakout Box Dimensions



D15 SUB/P
PART NO. M.1302.6972

Figure 6-5: General I/O Breakout Board Dimensions



DANAHER MOTION PART NUMBER	DANAHER MOTION SHORT DESCRIPTION
M.1302.6970	BKOUT BD,F1/F2,MMC-SD DR MT

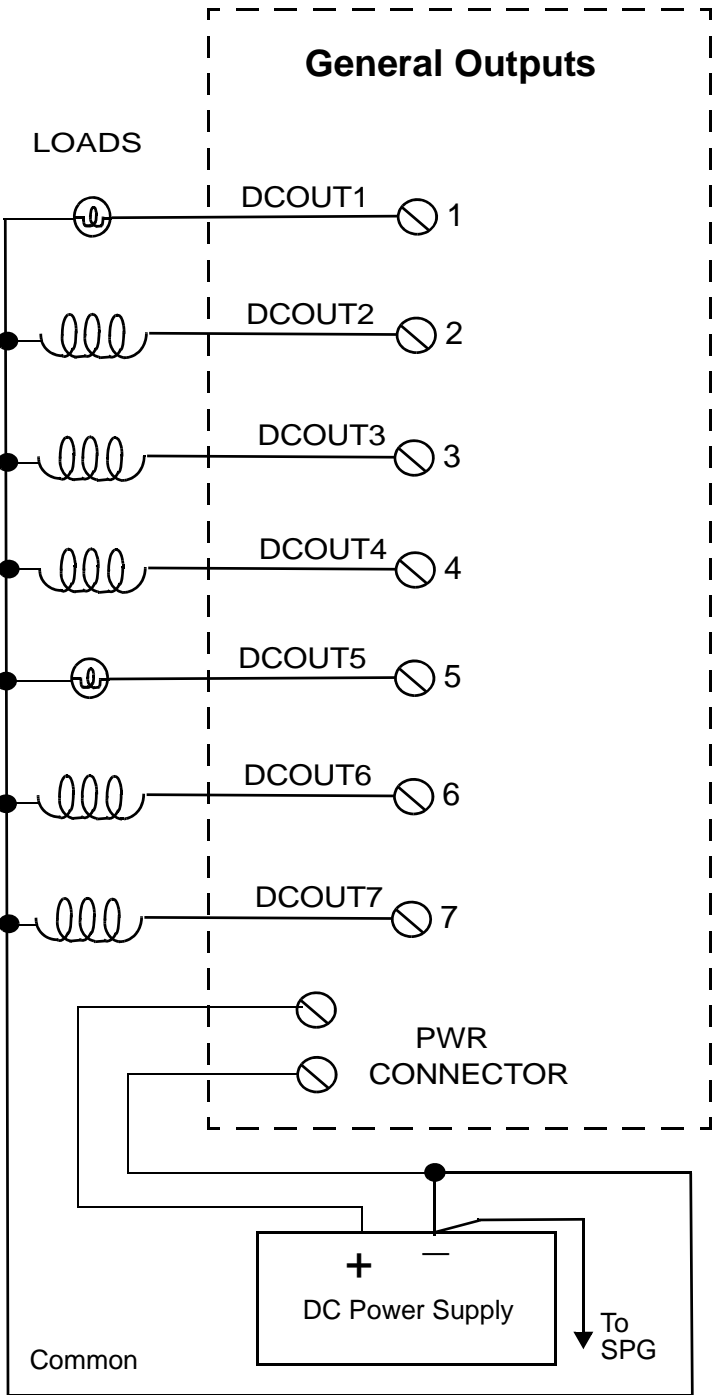
6.5.6.1 DC Output Operation

The General I/O Port provides 7 source-only 24 Vdc outputs. These outputs get their power from the PWR connector located on the Control. Each of the 7 outputs on the General I/O connector is a solid state switch rated at 250 ma. An example of connecting the DC Outputs to loads is shown in [Figure 6-6](#).

When a short circuit or overload condition is sensed, all Outputs are turned off and remain off for approximately 100 ms regardless of ladder activity. After 100 ms, the ladder again controls the Outputs. In addition, each output is protected with internal clamping diodes. Without clamping, high voltage transients (kickback) from inductive loads might damage the module.

For safety reasons, all outputs turn off (no current flow) when a scan loss condition occurs.

Figure 6-6: Connecting Output Devices to the General I/O Port

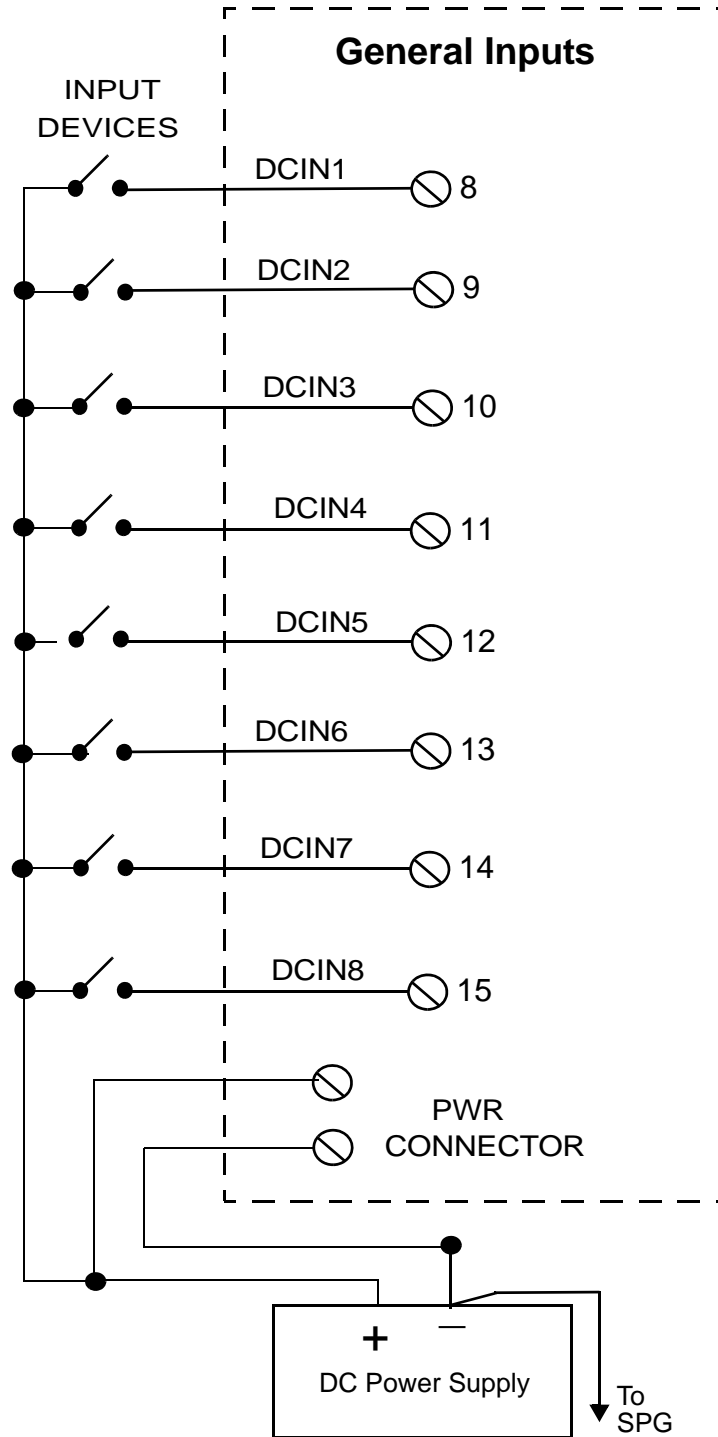


6.5.6.2 DC Input Operation

The General I/O Port provides eight 24 Vdc sourcing inputs (a nominal 24 Vdc at the Input turns the Input "on").

An example of connecting the DC Inputs to the Control is shown in [Figure 6-7](#).

Figure 6-7: Connecting Input Devices to the General I/O Port



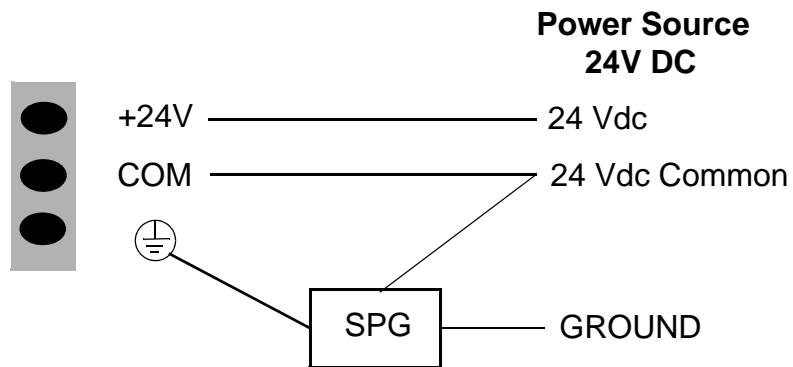
6.5.7 Power Connection

The Power connector (labeled “PWR” on the front of the Control) must be connected to a user-supplied +24 VDC power supply to provide power to the Control. The power supply screw terminal connection (3 pin) is at the bottom of the Control. [Figure 6-8](#) illustrates the pin-out.

The Control converts +24 Vdc power from this connector to DC power at voltages of +3.3 Vdc and +1.5V and supplies them to the logic side of the system. The same +24 Vdc supply that powers the Control also supplies the 24 Vdc Outputs located on the General I/O connector, as well as any attached MMC Option Modules.

CAUTION
Always shut off power at the main disconnect switch before you begin to work on the Control.

Figure 6-8: Pin Out for the 3-pin Power Supply Screw Terminal Connection



6.6 Specifications

General											
Characteristic		MMC Specifications									
		Number of servo axes available at six update rates ^a									
Model	Part No.	Speed	App Mem	RAM Mem	User Mem	8 ms	4 ms	2 ms	1 ms	.5 ms	.25 ms
MMC-DSA2	M.3000.0652	Std.	1.3M	256K	64K	2	2	2	2	2	1
MMC-DSA4	M.3000.0653	Std.	1.3M	256K	64K	4	4	4	4	2	1
MMC-DSA8	M.3000.0654	X1.5	1.3M	256K	64K	8	8	8	4-8	2-4	1-2
MMC-DSA16	M.3000.0655	X1.5	1.3M	256K	64K	16	16	8-16	4-8	2-4	1-2

a. Using features such as servo tasks, S-curve, RATIO_RL, M_LINCIR, M_SCRVLC, PLS, and CAM_OUT places a heavier burden on available CPU time. Consult Danaher Motion for assistance if you want to exceed the number of axes in this chart.

CPU	32 bit RISC processor with numeric coprocessor
Battery	3V Coin Cell, BR2032 lithium battery
CAUTION for Lithium Batteries Danger of explosion if battery is incorrectly replaced. Replace only with the same or equivalent type recommended by the manufacturer. Dispose of used batteries according to the manufacturer's instructions.	
Flash Disk	2 Megabytes
Memory	1 Megabyte max.
PiCPro Port (to workstation)	RS232 serial port, secured protocol Software selectable baud rate to 115.2K
User Port (to serial interface device)	RS232/RS485 serial port Supports RTS/CTS hardware handshaking Software selectable baud rate to 115.2K
Ethernet Port (to Ethernet Device)	IEEE 802.3/802.3u-100Base-TX/10Base T Half duplex Cable type: Shielded, Straight Pinned, CAT5 or better (CAT5e, CAT6, etc.) Maximum cable length: 50 M (164 ft)
Digital Link Ports (to Digital MMC Smart Drive)	IEEE 802.3/802.3u-100Base-TX Cable type: Shielded, Straight Pinned, CAT5 or better (CAT5e, CAT6, etc.) Maximum cable length: 30 M (98.4 ft)

Input voltage	20 VDC to 30 VDC
Input power	500mA plus I/O & MMC Option Module power (10 A max)
Time-of-day clock Clock tolerance	Access via PiCPro 10.2 and above or your application program At 25°C (77°F), ±1 second per day Over temperature, voltage and aging variation, +2/-12 seconds per day
CE Marked Note: Only units Rev 1 or higher are CE Marked.	Conforms to Directives 73/23/EEC, 89/336/EEC, 92/31/EEC, 93/68/EEC by conforming to the following standards: EN 50081-2:1993 EMC Generic Industrial Emissions EN 50082-2:1995 EMC Generic Industrial Immunity EN 61131-2:1994/A11:1996 Low voltage directive requirements for programmable controllers Operates with emissions below EN55011/ CISPR 11 Class A limits Immune to: <ul style="list-style-type: none"> • Electrostatic discharge (4K V contact mode, 8K V air discharge) per EN61000-4-2 • RF electromagnetic fields per EN61000-4-3, ENV 50141, and ENV50204 • Electrical fast transients per EN61000-4-4 • Magnetic fields per EN61000-4-8 Refer to the EMC Guidelines for more information.
UL and C/UL Listed	E126417
Physical size	2.25" wide x 9.6" high x 5.3" deep 57.15 mm x 243.84 mm x 134.62 mm
Vibration (per IEC 68-2-6)	10-57 Hz (constant amplitude = .15 mm) 57 - 2000 Hz (acceleration = 2 g)
Shock (per IEC 68-2-27)	Four shocks per axis (15g/11 msec)
General DC Inputs	
Configuration	Sourcing only. Operates with IEC Type 1 inputs (per IEC 1131-2)
Input voltage	Nominal 24 VDC, maximum 30 VDC
Guaranteed on voltage	15 VDC
Guaranteed off voltage	5 VDC
Turn on/off time	1 ms

General DC Outputs	
Number of outputs	7 outputs
Input voltage	Nominal 24 VDC, 30 VDC maximum
Configuration	Seven solid-state switches.
Protection of logic circuits	Optical isolation between the logic and field side, transient suppression on the 24V external supply
Maximum current	.25 A per output
Voltage range	24 VDC nominal, 5 to 30 VDC
Switch characteristics	Solid-state switches
Time delay on for resistive loads	50 μ sec max
Time delay off for resistive loads	50 μ sec max
Leakage current in off state	0.5 mA max
Switch voltage, maximum ON	1 VDC max
Over-current protection for entire group of 7 outputs	2 A (max) pulses for about 130 μ sec every 100 msec until over-current is removed
Short circuit protection for entire group of 7 outputs	15 A (max) pulses for about 130 μ sec every 100 msec until short is removed
Scan loss response	Outputs turn off

7 MMC Ethernet TCP/IP Option Module

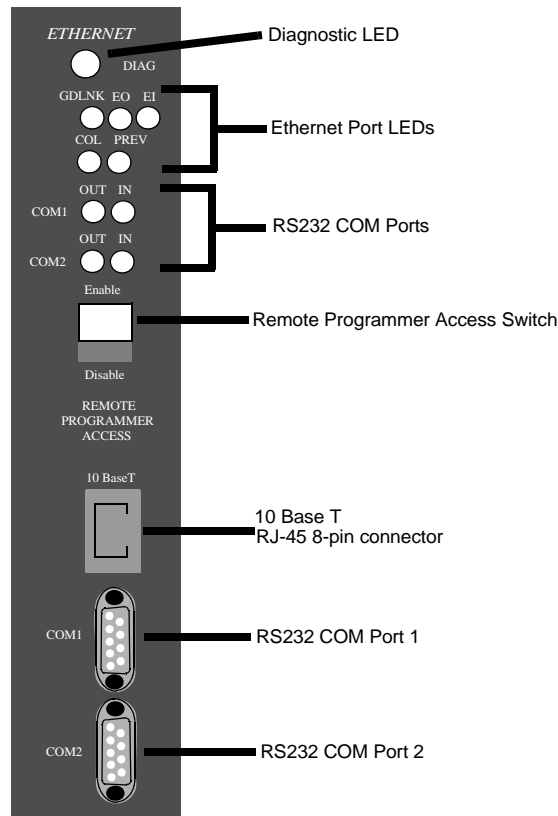
7.1 Introduction

The ETHERNET - TCP/IP Option Module provides the Standalone MMC Control (MMC-A2, -A4, -S8, -S16) with Ethernet access and Internet connectivity. This MMC Option module cannot be used with the Standalone Digital MMC Control (MMC-D32, -D64), or the MMC-DSAXX Control (MMC-DSA2, -DSA4, -DSA8, -DSA16). A 10Base T connection is provided following the IEEE 802.3 specification. The data transfer rate is 10 Mbps. Applications can range from connecting several MMCs, connecting groups of MMCs and PCs, or connecting to a system that includes Internet access.

At the end of this document is a partial list of Internet links to useful information about Ethernet and TCP/IP networking.

The Remote Programmer Access switch (future feature) will allow you to enable/disable MMC running over Ethernet. The DIAG LED goes on briefly while the diagnostic tests are running shortly after power is applied.

Figure 7-1: MMC Ethernet - TCP/IP Option Module

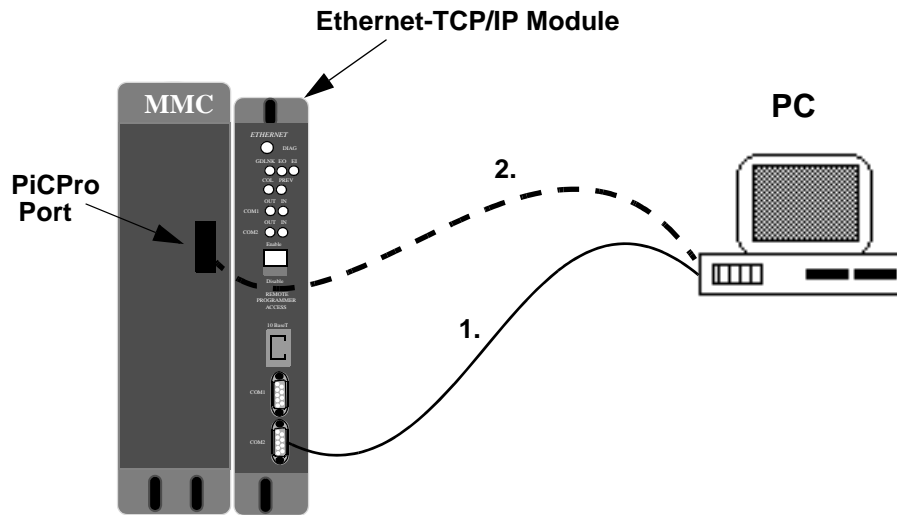


7.2 Connections

A serial cable is used to make a connection between the PC and the MMC Control, or between the PC and the Ethernet TCP/IP Option Module.

1. Connect the PC to the RS232 Com 2 Port on the Ethernet - TCP/IP module to download the TCP/IP configuration file (connection 1 as shown in [Figure 7-2](#)).
2. Connect the PC to the PiCPro Port on the CPU to download the application LDO (connection 2 as shown in [Figure 7-2](#)).

Figure 7-2: MMC/PC Connections

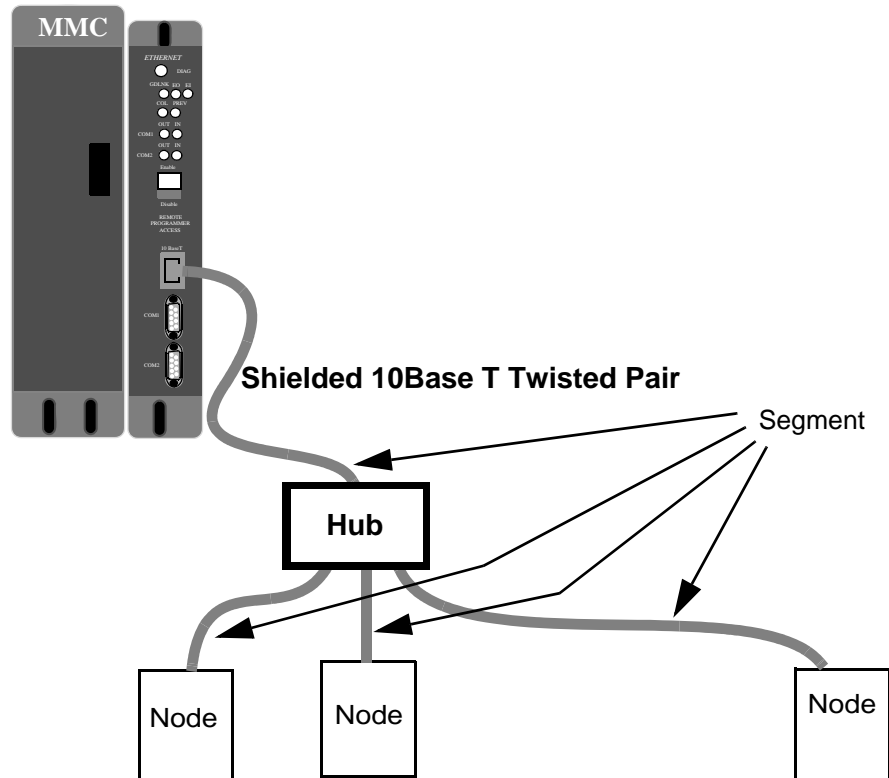


Use 10Base T (10 Mbps, baseband, over twisted pair cable) to set up your Ethernet - TCP/IP system. The table below summarizes the specifications (IEEE 802.3) for the Ethernet connection available on the MMC Ethernet - TCP/IP module.

Table 7-1: Ethernet Port Specifications	
Item	Specification
Type of Cable	Category 3 or 5 (5 recommended) UTP (shielded twisted-pair) Shielded category 5 cable is optional.
Connection	RJ-45
Topology	Star
Distance	100 M (328 ft) between transceiver (TCP/IP module) and hub
Maximum cable segment length	100 M (328 ft)
Data Rate	10 Mbps

A typical MMC 10Base T connection is shown below.

Figure 7-3: Ethernet - TCP/IP 10Base T Connections



Maximum segment length is 100 M (328 ft).

7.2.1 The Ethernet Port

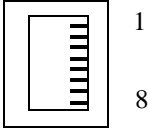
The 10Base-T port uses a RJ-45 style 8-pin connector using 100 ohm unshielded twisted pair category 3 or 5 cable (IEEE 802.3 section 14.4). The maximum length of the twisted pair cable segment is 100 M (328 ft). NOTE: The connector is also suitable for shielded cable and will ground the shield to the chassis.

- Pin descriptions for are provided in [Table 7-2](#)
- Pin assignments are provided in [Table 7-3](#)
- The available Ethernet Port to Ethernet Device cables are described in [Table 7-4](#)

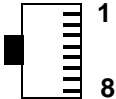

Table 7-2: Ethernet Port Pin Descriptions

Function	Notes	Pin
Receive Data +	Receives data from connected drives.	3
Receive Data -	Receives data from connected drives.	6
Transmit Data +	Transmits data to connected drives.	1
Transmit Data -	Transmits data to connected drives.	2
Shield Ground	Provides a path for shield current through the chassis to an external single point ground.	Shell

Table 7-3: Ethernet Port Pin Assignments

Pin	Signal	In/Out	Pin Sequence
1	Transmit Data +	Out	<p style="text-align: center;">RJ-45</p> 
2	Transmit Data -	Out	
3	Receive Data +	In	
4	Termination Resistors ^a	In	
5	Termination Resistors ^(a)	In	
6	Receive Data -	In	
7	Termination Resistors ^(a)	In	
8	Termination Resistors ^(a)	In	
Connector Shell	Shield	In	

a. Pins 4, 5, 7, and 8 are tied to termination resistors on the Module. Standard Ethernet cables contain 8 wires. The Module only uses 4 of these wires as shown. Connecting the 4 unused wires to pins 4, 5, 7, and 8, (as will be done in a standard Ethernet cable) reduces noise that can be induced from the unused wires to the Transmit and Receive wires.

Table 7-4: Ethernet Port to Ethernet Device Cables				
Part Numbers: .3 M (1.0 ft): M.1302.8285 .6 M (2.0 ft): M.1302.8286 1 M (3.3 ft): M.1302.8287 2 M (6.6 ft): M.1302.8288 3 M (9.8 ft): M.1302.8289 5 M (16.4 ft): M.1302.8300 10 M (32.8 ft): M.1302.8301 15 M (49.2 ft): M.1302.8302 30 M (98.4 ft): M.1302.8303 Cable type: 28 AWG, shielded, twisted pair, 8 conductor.				
8-Pin RJ-45 Plug (to Ethernet Port, face view) 		8-Pin RJ-45 Plug (to Ethernet Device, face view) 		
Pin	Signal	Pin	Signal	Notes
1	Transmit Data +	1	Receive Data +	Twisted
2	Transmit Data -	2	Receive Data -	Pair
3	Receive Data +	3	Transmit Data +	Twisted
6	Receive Data -	6	Transmit Data -	Pair
4	None	4	None	Twisted
5	None	5	None	Pair
7	None	7	None	Twisted
8	None	8	None	Pair
Shell	Drain	Shell	Drain	

7.2.2 The RS232 COMM Ports

There are two RS232 ports at the top of the module as shown in Figure 4-3. COMM 1 will be used for modem connections (future). COMM 2 is used to download your configuration file to the MMC.

- Pin descriptions for are provided in [Table 7-5](#)
- Pin assignments are provided in [Table 7-6](#)
- The available PiCPro Port to PC cable is described in [Table 7-7](#)

Table 7-5: COMM Port Pin Descriptions

Function	Notes	Pin
Receive Data	RS232-level signal that receives serial data from the connected PC running PiCPro.	2
Transmit Data	RS232-level signal that transmits serial data to the connected PC running PiCPro.	3
Signal Ground	Provides the return path for signals	5
Data Terminal Ready	Always high (greater than +3 Vdc)	4
Request-to-send	RS232-level signal that indicates to the connected serial device that it can transmit data to the Module.	7
Clear-to-send	RS232-level signal that indicates to the Module that it can transmit data to the connected serial device.	8
Shield Ground	Provides a path for shield current through the chassis to an external single point ground.	Connector Shell

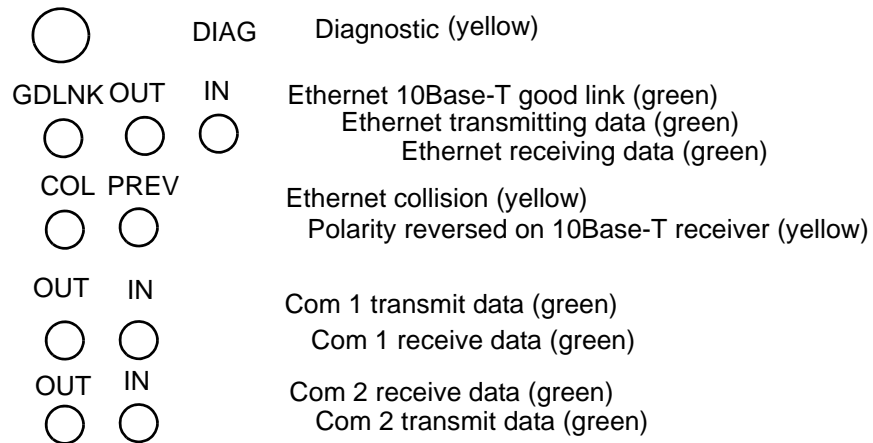
Table 7-6: COMM Port Pin Assignments

Pin	Signal	In/Out	Pin Sequence
1	NC	N/A	<p>9-pin male D-sub</p>
2	RS232 Receive Data	In	
3	RS232 Transmit Data	Out	
4	NC	NA	
5	Signal Ground	In/Out	
6	NC	N/A	
7	Request-to-send	Out	
8	Clear-to-send	In	
9	NC	N/A	
Connector Shield	Shield	In	

Table 7-7: COMM Port to PC Cable				
Part Number: M.1302.8250 Length: 4 M (13 ft) Cable type: 24 AWG, shielded, twisted pair, 4 conductor.				
9-Pin female D-sub (to COMM Port, face view)		9-Pin female D-sub (to PC COM Port, face view)		
Pin	Signal	Pin	Signal	Notes
2	Receive Data	3	Transmit Data	Twisted
3	Transmit Data	2	Receive Data	Pair
5	Signal Ground	5	Signal Ground	
Shell	Drain	Shell	Drain	

7.3 LEDs

There are nine LEDs on the MMC Ethernet - TCP/IP module in addition to the DIAG LED. They are located directly under the DIAG LED as shown below.

Figure 7-4: Ethernet - TCP/IP LEDs

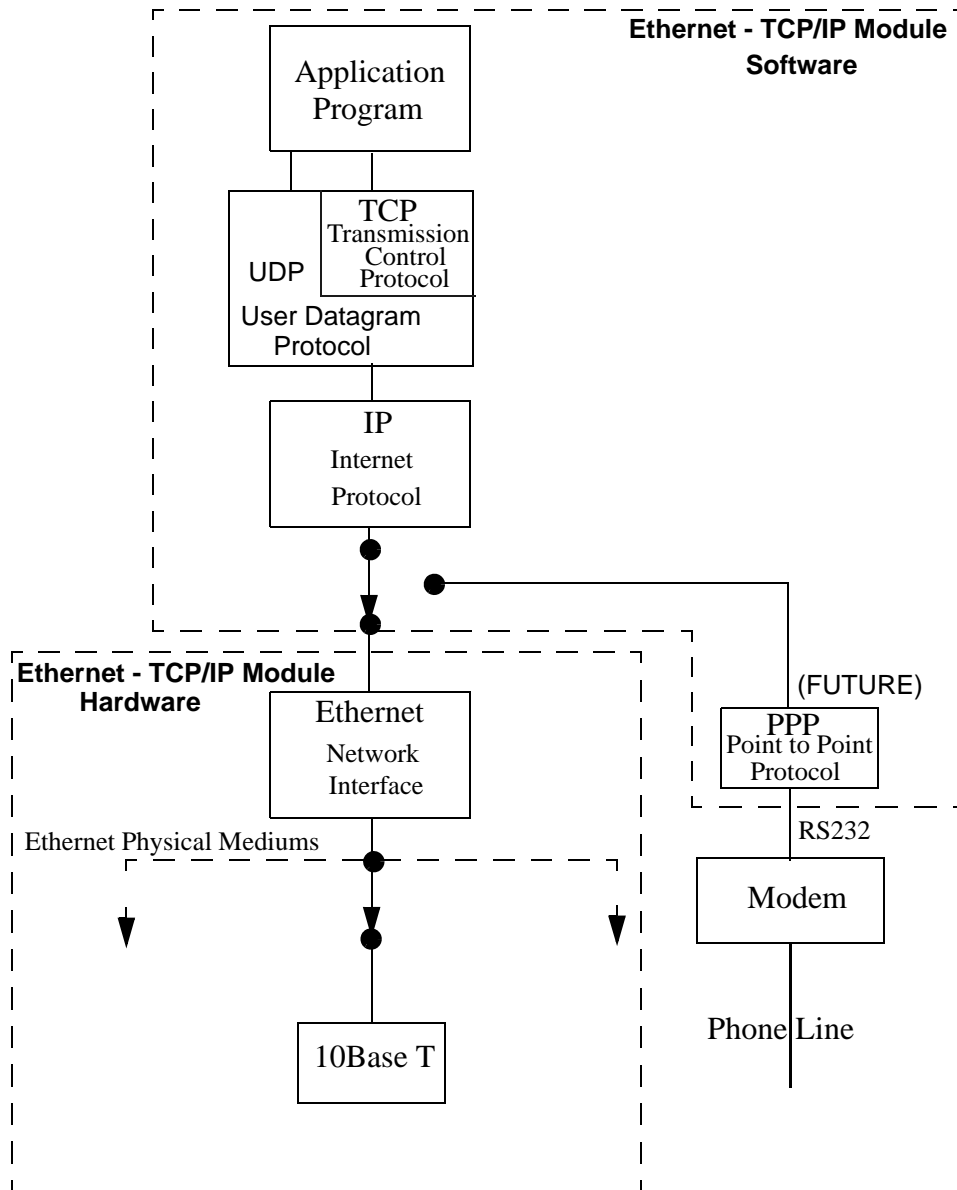
7.4 Firmware Update

See Appendix B of the PiCPro online help for firmware update information.

7.5 Theory of operation

The MMC Ethernet - TCP/IP module contains a 32-bit processor to handle TCP/IP, PPP (future), and Ethernet protocols. It allows you to use the Ethernet network architecture and the TCP/IP standard set of protocols to communicate and access other modules, computers, or the Internet and its resources. The design is based on the IEEE 802.3 specifications. The data rate is 10 Mbps. The diagram below provides an overview.

Figure 7-5: MMC Ethernet - TCP/IP Overview



7.6 Specifications Table

Characteristics	Ethernet - TCP/IP Module Specifications
Function	Provides the MMC with Ethernet access and Internet connectivity
Part number	M.1017.3888
RS232 Port 1	Com Port 1 modem (future)
RS232 Port 2	Com Port 2 (for firmware and configuration loading)
10Base T	RJ-45 8-pin connector Maximum twisted pair length is 100 M (328 ft).
24 VDC Power from the MMC	200 mA
Operating temperature range	7° C to 55° C (45° F to 131° F)
Storage temperature range	-40° C to 85° C (-40° F to 185° F)
Humidity	5 to 95%, non-condensing
CE Marked	<p>Conforms to Directives 73/23/EEC, 89/336/EEC, 92/31/EEC, 93/68/EEC by conforming to the following standards:</p> <p>EN 50081-2:1993EMC Generic Industrial Emissions EN 50082-2:1995EMC Generic Industrial Immunity EN 61131-2:1994/A11:1996 Low voltage directive requirements for programmable controllers Operates with emissions below EN55011/ CISPR 11 Class A limits Immune to:</p> <ul style="list-style-type: none"> • Electrostatic discharge (4K V contact mode, 8K V air discharge) per EN61000-4-2 • RF electromagnetic fields per EN61000-4-3, ENV 50141, and ENV50204 • Electrical fast transients per EN61000-4-4 • Magnetic fields per EN61000-4-8 <p>Refer to the EMC Guidelines for more information.</p>
UL and C/UL Listed	E126417
Physical size	1.28" wide x 9.6" high x 5.3" deep 52.51 mm x 243.84 mm x 134.62 mm
Vibration (per IEC 68-2-6)	10-57 Hz (constant amplitude = .15 mm) 57 - 2000 Hz (acceleration = 2 g)
Shock (per IEC 68-2-27)	Four shocks per axis (15g/11 msec)

7.7 Useful Internet Links

http://www.3com.com/technology/tech_net/white_papers/500698.html#6

<http://www.library.ucg.ie/Connected/Course/index.htm>

<http://www.combsnet.com/cable/Basics/types.html>

http://www.jdltech.com/solutions/Standards_Terms.cfm

http://www.jdltech.com/solutions/LAN_terms.cfm

http://www.datatech.com/hot/w96_2.htm

<http://www.standards.ieee.org/catalog/IEEE802.3.html>

<http://www.3com.com/nsc/glossary/main.htm>

http://www.alliedtelesyn.com/prd_tran.htm#microtrans

http://www.lothlorien.net/collections/computer/ethernet_frames.html

<http://www.lantronix.com/htmlfiles/mrktg/catalog/etntba.htm>

<http://www.warehouse.com/datacomm/>

8 MMC DeviceNet™ Option Module

8.1 Introduction

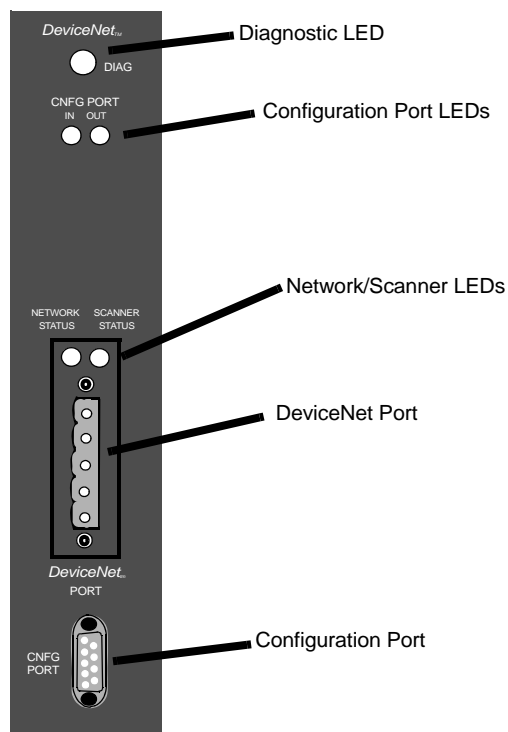
The MMC DeviceNet™ scanner module is an interface between any MMC Control and a DeviceNet network. The module contains an on-board processor, a DeviceNet compliant interface, and firmware that makes it act as the master to all other nodes on the network.

Prior to initial operation, a file is generated with specific configuration software in an external PC. This file must be downloaded via the RS232 configuration port to the DeviceNet module prior to initial operation. Two indicator LEDs (IN/OUT) are connected to this configuration port.

Directly above the DeviceNet port are two LEDs that provide operation information: Network Status and DeviceNet Scanner Status.

The DIAG LED goes on briefly while the diagnostic tests are running.

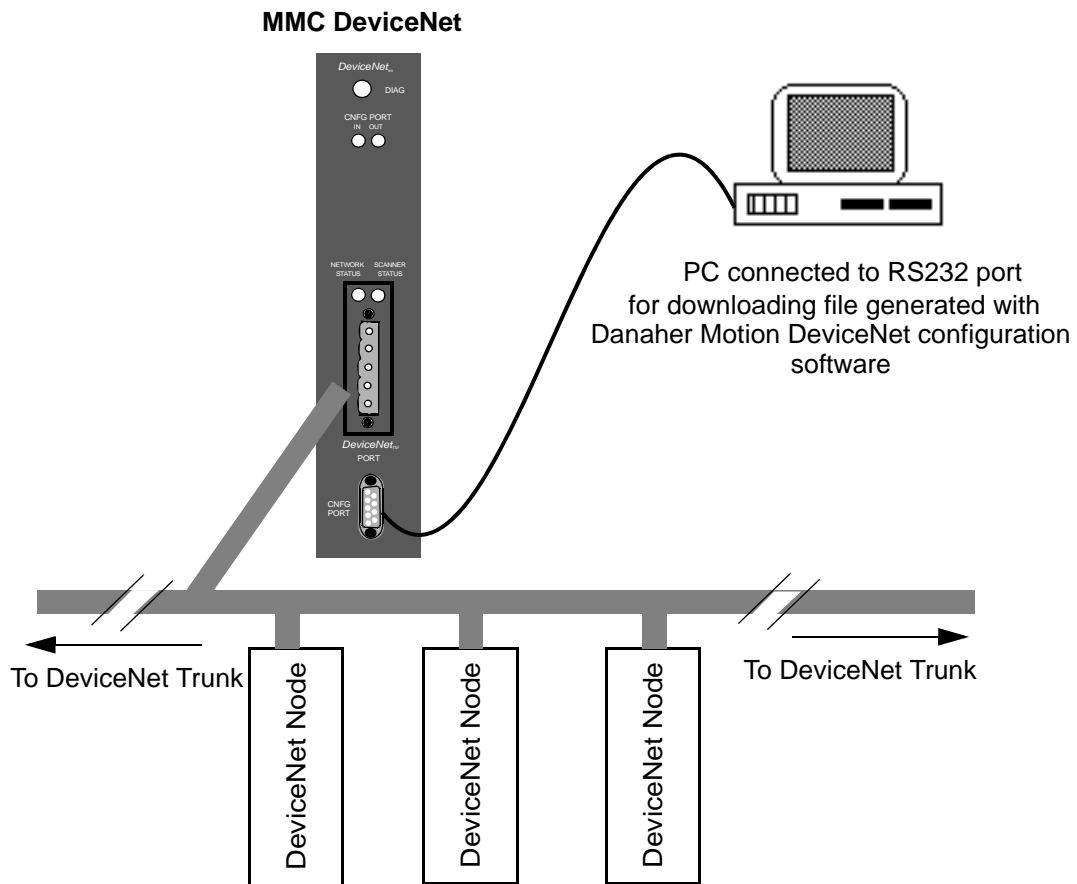
Figure 8-1: MMC DeviceNet Module



8.2 Connections

DeviceNet connections are illustrated in [Figure 8-2](#). Up to 63 DeviceNet Nodes may be attached to the DeviceNet scanner module.

Figure 8-2: DeviceNet Connections



8.2.1 The DeviceNet Port

The DeviceNet port is on the front of the module near the center as shown in [Figure 8-1 on page 163](#). The pinout for the DeviceNet port is shown below:

Pin #	Signal Name	Standard Wire Colors
1	V-	black
2	CAN_L	blue
3	Shield (drain)	bare
4	CAN_H	white
5	V+	red

In your network layout, follow DeviceNet specifications. Only use DeviceNet compliant cable, such as Belden 3084A thin wire and Belden 3082A thick wire.

8.2.2 The Configuration (RS232) Port

There is an RS232 port on the lower front of the module as shown in [Figure 8-1 on page 163](#). This is used to connect to a PC in order to download a file representing your DeviceNet network.

Pin #	Signal Name	In/Out
2	Receive Data	In
3	Transmit Data	Out
5	Ground	In/Out

8.3 LEDs

The two configuration port LEDs and the two DeviceNet port LEDs are described below.

Port	LED	Color	State	Definition	
DeviceNet Port	Network status	None	OFF	Off-line	
		Green	ON	On-line and connected to at least one node	
			Flashing	On-line but connection nodes not established	
		Red	ON	Unrecoverable Fault (duplicate MAC ID check failed, critical bus fault etc.)	
			Flashing	I/O connections in timed-out state or other Recoverable Fault	
	Scanner status	Green		OFF	No power or else reset asserted
				ON	Scanner OK and active
				Flashing	Scanner OK but not active
		Red		ON	Hardware or software error
				Flashing	Recoverable configuration error (invalid data downloaded)
	Orange	ON	Configuration (download) mode		
Configuration Port	IN	Red	Flickering	Data is being passed to the module	
			OFF	No data to the module	
	OUT	Red	Flickering	Data is being passed from the module	
			OFF	No data from the module	

8.4 Theory of Operation

The DeviceNet scanner module provides a memory image of the nodes (slaves) connected to a DeviceNet network. It is this memory image that is controlled by your LDO created in PICPro. The module's on-board processor continually transfers data between this memory image and the actual DeviceNet nodes.

Communication between the DeviceNet module and the nodes can be set at 125 Kbaud, 250 Kbaud, or 500 Kbaud. The baud rate, the relationship between the memory image and specific data in each node, and other parameters are established with configuration software run in an external PC.

This configuration software generates two files. One file is downloaded to the DeviceNet module through its RS232 serial port. The other file is used by PiCPro to establish the relationship between the memory image and the declared variables in the LDO. To ensure that a given location in the memory image is connected to a variable in the LDO and to the corresponding data in the DeviceNet node, the same tag name or label must be used.

For example, when running the configuration software, PROX_SW1 could be used as the name for the boolean bit representing a DeviceNet proximity switch's logic state. The name PROX_SW1 must also be used for the corresponding variable in your LDO.

NOTE

The Danaher Motion DeviceNet configuration software (Danaher Motion Part No. M.1017.4267) is required to configure the DeviceNet scanner (within the DeviceNet module) for the devices on the associated network.

NOTE

Additional information about DeviceNet can be obtained from www.odva.org.

8.5 Specifications

Characteristics	DeviceNet Module Specifications
Function	Interfaces to a DeviceNet network with up to 63 other nodes
Part number	M.1017.3889
DeviceNet Port	Phoenix style 5-pin male connector
Configuration Port	RS232 interface
24 V DC Power from the MMC	100 mA
Operating temperature range	7° C to 55° C (45° F to 131° F)
Storage temperature range	-40° C to 85° C (-40° F to 185° F)
Humidity	5 to 95%, non-condensing
CE Marked	<p>Conforms to Directives 73/23/EEC, 89/336/EEC, 92/31/EEC, 93/68/EEC by conforming to the following standards:</p> <p>EN 50081-2:1993EMC Generic Industrial Emissions</p> <p>EN 50082-2:1995EMC Generic Industrial Immunity</p> <p>EN 61131-2:1994/A11:1996 Low voltage directive requirements for programmable controllers</p> <p>Operates with emissions below EN55011/ CISPR 11</p> <p>Class A limits</p> <p>Immune to:</p> <ul style="list-style-type: none"> • Electrostatic discharge (4K V contact mode, 8K V air discharge) per EN61000-4-2 • RF electromagnetic fields per EN61000-4-3, ENV 50141, and ENV50204 • Electrical fast transients per EN61000-4-4 • Magnetic fields per EN61000-4-8 <p>Refer to the EMC Guidelines for more information.</p>
UL and C/UL Listed	File No. E126417 NRAQ Programmable Controllers
Physical size	1.28" wide x 9.6" high x 5.3" deep 52.51 mm x 243.84 mm x 134.62 mm
Vibration (per IEC 68-2-6)	10-57 Hz (constant amplitude = .15 mm) 57 - 2000 Hz (acceleration = 2 g)
Shock (per IEC 68-2-27)	Four shocks per axis (15g/11 msec)

9 MMC Profibus Option Module

9.1 Introduction

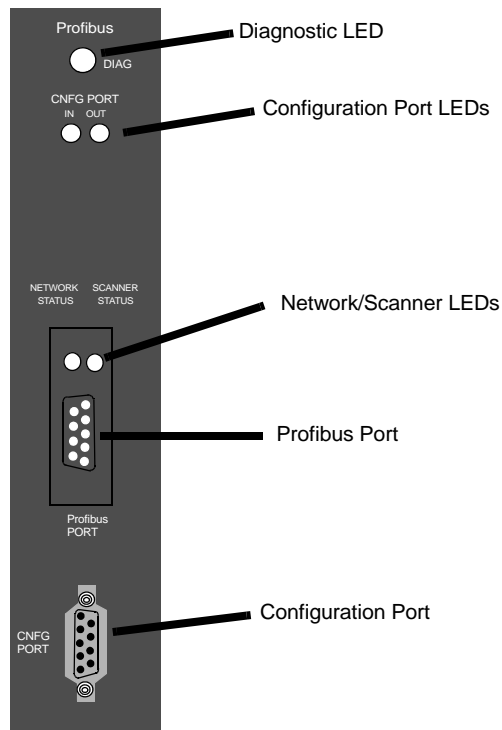
The MMC Profibus scanner module is an interface between any MMC Control and a Profibus network. The module contains an on-board processor, a Profibus compliant interface, and firmware that makes it act as the master to all other nodes on the network.

Prior to initial operation, a file is generated with specific configuration software in an external PC. This file must be downloaded via the RS232 configuration port to the Profibus module prior to initial operation. Two indicator LEDs (IN/OUT) are connected to this configuration port.

Directly above the Profibus port are two LEDs that provide operation information: Network Status and Profibus Scanner Status.

The DIAG LED goes on briefly while the diagnostic tests are running.

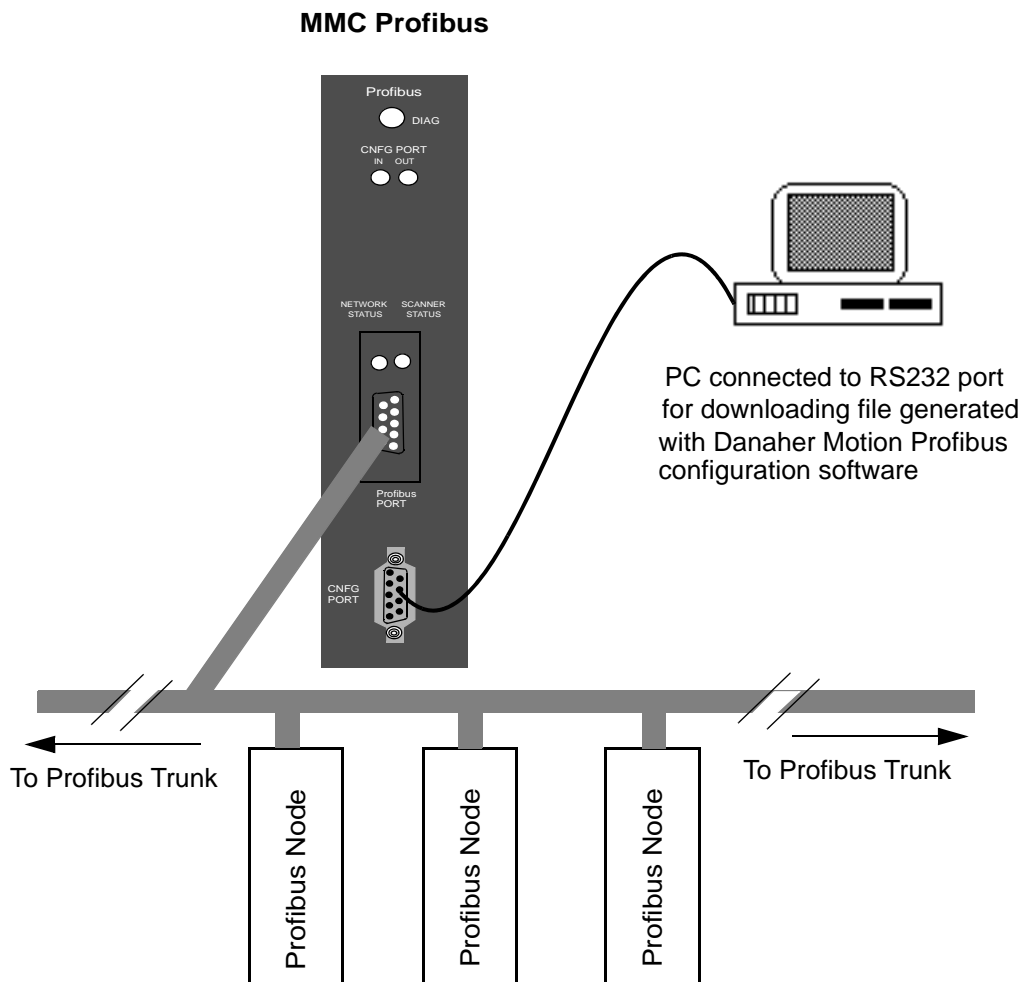
Figure 9-1: MMC Profibus Module



9.2 Connections

Profibus connections are illustrated in [Figure 9-2 on page 170](#). Up to 31 Profibus nodes, without repeaters, may be attached to the Profibus scanner. Up to 125 other Profibus Nodes, using repeaters, may be attached to the Profibus scanner module.

Figure 9-2: Profibus Connections



9.2.1 The Profibus Port

The Profibus port is on the front of the module near the center as shown in [Figure 9-1 on page 169](#). The pinout for the Profibus port is shown below.

Pin #	Signal Name	
1	Chassis ground	<p>Note: It is strongly recommended that you use Profibus Sub-D connectors with switchable (ON/OFF) termination, such as Siemens 6ES7 972-0BA11-0XA0 or 6ES7 972-0BB11-0XA0. Only use Profibus type A cable, such as Belden 3079A or Siemens 6XV1 830-0AH10.</p>
2	reserved	
3	data +	
4	Tx enable	
5	Isolated ground	
6	voltage plus	
7	reserved	
8	data -	
9	reserved	

9.2.2 The Configuration (RS232) Port

There is an RS232 port on the lower front of the module as shown in [Figure 9-1 on page 169](#). This is used to connect to a PC in order to download a file representing your Profibus network.

Pin #	Signal Name	In/Out
2	Receive Data	In
3	Transmit Data	Out
5	Ground	In/Out

9.3 LEDs

The two configuration port LEDs and the two Profibus port LEDs are described below.

Port	LED	Color	State	Definition	
Profibus Port	Network status	Green	OFF	Off-line	
			ON	On-line, no physical layer or data layer errors (or Profibus cable not connected)	
		Red	ON	On-line, bus error (baud rate or wiring problem)	
	Scanner status	Green	OFF	No power or else reset asserted, interface closed	
			ON	Scanner communicating, data exchanging, no slave device errors	
			Flashing	Scanner in start-up	
		Red	ON	At least one slave faulted	
		Orange	ON	Configuration (download) mode	
	Configuration Port	IN	Red	Flickering	Data is being passed to the module
				OFF	No data to the module
OUT		Red	Flickering	Data is being passed from the module	
			OFF	No data from the module	

9.4 Theory of Operation

The Profibus scanner module provides a memory image of the nodes (slaves) connected to a Profibus network. It is this memory image that is controlled by your LDO created in PiCPro. The module's on-board processor continually transfers data between this memory image and the actual Profibus nodes.

Communication between the Profibus module and the nodes can be set between 9600 baud (1200m max.) and 12M baud (100m max.). The baud rate, the relationship between the memory image and specific data in each node, and other parameters are established with configuration software run in an external PC.

This configuration software generates two files. One file is downloaded to the Profibus module through its RS232 serial port. The other file is used by PiCPro to establish the relationship between the memory image and the declared variables in the LDO. To ensure that a given location in the memory image is connected to a variable in the

LDO and to the corresponding data in the Profibus node, the same tag name or label must be used.

For example, when running the configuration software, PROX_SW1 could be used as the name for a boolean bit of a Profibus Block I/O. It would correspond to the wiring location of a proximity switch. The name PROX_SW1 must also be used for the corresponding variable in your LDO.

The Profibus scanner module provides DP master Class 1 functionality only. This includes DP multi-master support (token) passing and cyclic slave communications. It does not support DP master Class 2, sync and freeze modes, nor extended DP functions.

NOTE

The Danaher Motion Profibus configuration software (Danaher Motion Part No. M.1300.7794) is required to configure the Profibus scanner (within the Profibus module) for the devices on the associated network.

NOTE

Additional information about Profibus can be obtained at www.profibus.com

9.5 Specifications for Profibus Module

Characteristics	Profibus Module Specifications
Function	Interfaces (acts as DP Master - Class 1), to a Profibus network with up to 125 other nodes, using repeaters
Part number	M.1300.7167
Profibus Port	9-pin female D-sub connector
Configuration Port	RS232 interface
24 V DC Power from the MMC	100 mA
Operating temperature range	7° C to 55° C (45° F to 131° F)
Storage temperature range	-40° C to 85° C (-40° F to 185° F)
Humidity	5 to 95%, non-condensing
CE Marked	<p>Conforms to Directives 73/23/EEC, 89/336/EEC, 92/31/EEC, 93/68/EEC by conforming to the following standards:</p> <p>EN 50081-2:1993 EMC Generic Industrial Emissions</p> <p>EN 50082-2:1995 EMC Generic Industrial Immunity</p> <p>EN 61131-2:1994/A11:1996 Low voltage directive requirements for programmable controllers</p> <p>Operates with emissions below EN55011/ CISPR 11 Class A limits</p> <p>Immune to:</p> <ul style="list-style-type: none"> • Electrostatic discharge (4K V contact mode, 8K V air discharge) per EN61000-4-2 • RF electromagnetic fields per EN61000-4-3, ENV 50141, and ENV50204 • Electrical fast transients per EN61000-4-4 • Magnetic fields per EN61000-4-8 <p>Refer to the EMC Guidelines for more information.</p>
UL and C/UL Listed	File No. E126417 NQA Programmable Controllers
Physical size	1.28" wide x 9.6" high x 5.3" deep 52.51 mm x 243.84 mm x 134.62 mm
Vibration (per IEC 68-2-6)	10-57 Hz (constant amplitude = .15 mm) 57 - 2000 Hz (acceleration = 2 g)
Shock (per IEC 68-2-27)	Four shocks per axis (15g/11 msec)

10 MMC Axis I/O Option Module

The MMC Axis I/O Module can be used with any MMC control except the Sercos versions of the Standalone MMC Control (MMC-S8, -S16).

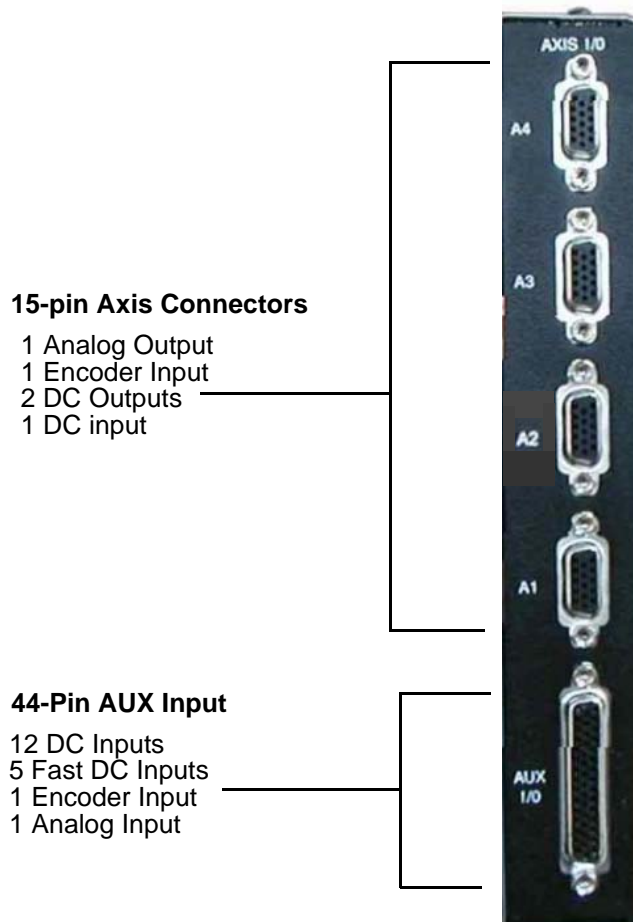
The MMC Axis I/O Option Module may be used in one of two ways:

- to provide conventional analog/digital interfacing to four analog drives (the Axis is declared in Servo Setup). This mode of operation is only available when used with the Analog versions of the Standalone MMC Control (MMC-A2, MMC-A4).
- to provide the following individual functions accessed from the user program (the Axis is not declared in Servo Setup):
 - D/A converter
 - feedback channels
 - on-board DC I/O

When a channel is declared as an Axis in Servo Setup, the typical signals needed to interface to an analog drive are provided by the MMC Axis I/O Option Module. The drive command is in the form of an analog voltage ($\pm 10V$). Feedback is accepted from quadrature type encoders with differential outputs. Digital I/O (+24 Vdc) is used for drive signals such as enable, reset, and fault. Fast inputs are provided for each encoder input and can be configured to latch encoder position under various conditions.

The MMC Axis I/O Option Module is identical to the Analog Motion Control section of the Standalone MMC Control. See [section 4.6 on page 64](#), **Analog Motion Control Connectors & Operation**, for connections and operation of the MMC Axis I/O Option Module.

Figure 10-1: Locations of Input, Output, Encoder Pins



10.1 Specifications

General	
Function	Provide the MMC with conventional analog/digital interfacing to four analog drives or analog/digital I/O, depending on MMC Control type.
Part Number	M.1302.6178
Operating temperature range	5°C to 55°C (41°F to 131°F)
Storage temperature range	-40°C to 85°C (-40°F to 185°F)
Humidity	5 to 95%, non-condensing
CE Marked	<p>Conforms to Directives 73/23/EEC, 89/336/EEC, 92/31/EEC, 93/68/EEC by conforming to the following standards:</p> <p>EN 50081-2:1993EMC Generic Industrial Emissions</p> <p>EN 50082-2:1995EMC Generic Industrial Immunity</p> <p>EN 61131-2:1994/A11:1996 Low voltage directive requirements for programmable controllers</p> <p>Operates with emissions below EN55011/ CISPR 11</p> <p>Class A limits</p> <p>Immune to:</p> <ul style="list-style-type: none"> • Electrostatic discharge (4K V contact mode, 8K V air discharge) per EN61000-4-2 • RF electromagnetic fields per EN61000-4-3, ENV 50141, and ENV50204 • Electrical fast transients per EN61000-4-4 • Magnetic fields per EN61000-4-8 <p>Refer to the EMC Guidelines for more information.</p>
UL and C/UL Listed	E126417
Physical size	1.28" wide x 9.6" high x 5.3" deep 52.51 mm x 243.84 mm x 134.62 mm
Vibration (per IEC 68-2-6)	10-57 Hz (constant amplitude = .15 mm) 57 - 2000 Hz (acceleration = 2 g)
Shock (per IEC 68-2-27)	Four shocks per axis (15g/11 msec)

Axis Port Analog Output	
Output channels	2 or 4
Resolution	16 bits
Output voltage range	± 10 VDC
Maximum output current (1K Ω load)	± 10 mA
Power on output voltage	0 V ± 100 mV
Scan loss output voltage	0V ± 100 mV
Accuracy	$\pm 0.375\%$ of FSR Drift ± 50 ppm/ $^{\circ}$ C
Update rate	68 μ sec
Aux Port Analog Input	
Input channel	1
Resolution	12 bits
Input voltage range	± 10 V
Accuracy	$\pm 0.2\%$ of FSR
Sample rate	100 μ sec
Common mode filter	3 dB @ 10 K Hz
Differential mode filter	3 dB @ 475 Hz

Axis Port & Aux Port Encoder Input	
Input channels	3 or 5
Input receiver	26632 differential RS422 receiver
Recommended Encoder Drivers	7272, 75183, 8830, 75114, 9614, 26LS31 (or equivalent)
Encoder signals	Differential quadrature
Input threshold	±750 mV
Input termination	120 ohm, provided on board
Maximum input voltage	5 V
Maximum A or B input frequency	250 K Hz (1 M feedback unit count rate)
Fast input voltage	Nominal 24 VDC, maximum 30 VDC
Guaranteed on voltage	15 VDC
Guaranteed off voltage	5 VDC
Turn on/off time	1 ms
Axis Port & Aux Port DC Inputs	
Configuration	The auxiliary inputs are divided into two groups of six inputs. Each group can be configured for sourcing or sinking. The axis inputs have one input per axis. Each input can be configured for sourcing or sinking. Operates with IEC Type 1 inputs (per IEC 1131=2).
Input voltage	Nominal 24 VDC, maximum 30 VDC
Guaranteed on voltage	15 VDC
Guaranteed off voltage	5 VDC
Turn on/off time	1 ms
Fast inputs	50 µsec
Axis Port DC Outputs	
Number of outputs	2 outputs per axis
Configuration	Each set of axis outputs can be configured as sourcing or sinking.
Maximum current	100 mA per output
Voltage range	24 VDC nominal, 5 to 30 VDC range
Scan loss response	Outputs turn off

Aux Port +5 Vdc Output	
+5 VDC	150 mA maximum current available. Connections to this point should be over short distances and away from electric noise signals.

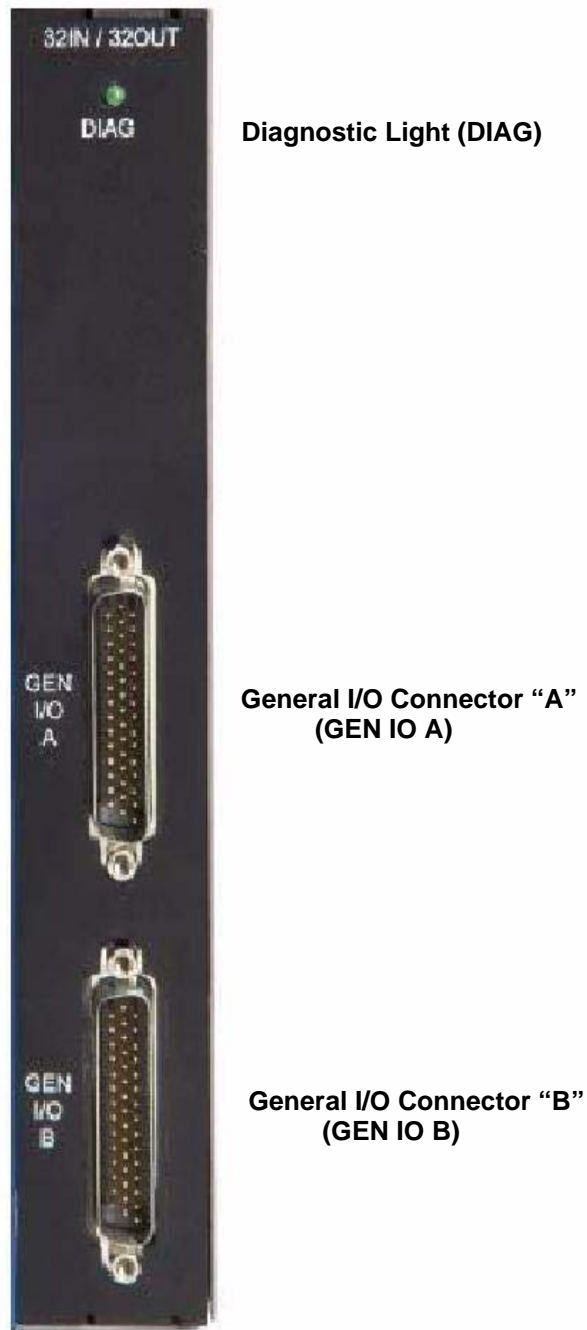
11 MMC 32In/32Out Option Module

11.1 Introduction

The MMC 32In/32 Out Option Module (shown in [Figure 11-1](#)) can be used with any MMC control. It contains two 44-pin HD male D-sub connectors, labeled “GEN I/O A”, and “GEN I/O B”. Each connector provides 16 sink or source (user selectable, in groups of 8) 24 Vdc inputs. In addition, the first input of each group of 8 can be programmed to provide a processor interrupt on either a low-to-high or high-to-low input transition. Each connector also provides 16 source-only 24 Vdc outputs. Each output is capable of sourcing 250 ma, and is protected from both short circuits as well as overloads.

The Diagnostic light at the top of the module (labeled “DIAG”), turns on briefly when power is first applied, and then turns off indicating that the module has passed it’s diagnostic tests. If the light stays on after power up, it is defective and should be replaced.

Figure 11-1: MMC 32 In/32 Out Option Module



11.2 Connections & Operation

The two 44-pin HD male D-sub I/O connectors (labeled "GEN I/O A" and "GEN I/O B" on the front of the Module) provides connection between the user I/O devices the

Control. This port provides 16 source-only outputs (described in detail in [section 11.2.1 on page 186](#)), and 16 sink or source inputs (described in detail in [section 11.2.2 on page 189](#)).

- Pin descriptions are provided in [Table 11-1](#)
- Pin assignments are provided in [Table 11-2](#)
- The available Flying Lead cable is described in [Table 11-3](#).
- Available Breakout Boxes and Cables are described in [Table 11-4](#).
- Breakout Box dimensions are shown in [Figure 11-2](#)

Table 11-1: General I/O Port Pin Descriptions		
Function	Notes	Pin
DC Outputs 1-16	Nominal 24 Vdc Outputs capable of sourcing up to 250 ma.	1-16
24 Vdc Output Power for Outputs 1-8	User-supplied 24 Vdc power (nominal) that supplies the necessary current to power DC Outputs 1-8.	17,31
24 Vdc Output Power for Outputs 9-16	User-supplied 24 Vdc power (nominal) that supplies the necessary current to power DC Outputs 9-16.	18,32
24 Vdc Common for Outputs 1-16	User-supplied 24 Vdc Common that supplies the return path for the DC Output logic current.	33
DC Inputs 1-8	Nominal 24 Vdc Inputs (Sink or Source) Inputs 1-8	23-30
Sink/Source select pin for DC Inputs 1-8	To make DC Inputs 1-8 “sourcing” inputs (24 Vdc applied to the DC Input turns the input “on”), connect 24 Vdc Common to this pin. To make DC Inputs 1-8 “sinking” inputs (24 Vdc Common applied to the DC Input turns the input “on”), connect 24 Vdc (nominal) to this pin.	21
DC Inputs 9-16	24 Vdc (nominal) Inputs (Sink or Source) 9-16.	37-44
Sink/Source select pin for DC Inputs 9-16	To make DC Inputs 9-16 “sourcing” inputs (24 Vdc applied to the DC Input turns the input “on”), connect 24 Vdc Common to this pin. To make DC Inputs 9-16 “sinking” inputs (24 Vdc Common applied to the DC Input turns the input “on”), connect 24 Vdc (nominal) to this pin.	35
Shield Ground	Provides a path for shield current through the chassis to an external single point ground.	Shell

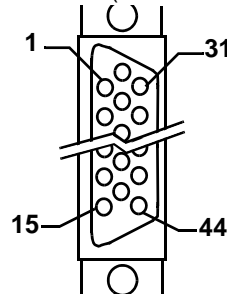
Table 11-2: General I/O Port Pin Assignments

Pin	Signal	In/Out	Connector Pinout		
1	DCOUT1	Out	<p>44-pin HD male D-sub</p>		
2	DCOUT2	Out			
3	DCOUT3	Out			
4	DCOUT4	Out			
5	DCOUT5	Out			
6	DCOUT6	Out			
7	DCOUT7	Out			
8	DCOUT8	Out			
9	DCOUT9	Out			
10	DCOUT10	Out			
11	DCOUT11	Out			
12	DCOUT12	Out			
13	DCOUT13	Out			
14	DCOUT14	Out			
15	DCOUT15	Out			
16	DCOUT16	Out			
17	DCOUTPWR1	In	Pin	Signal	In/Out
18	DCOUTPWR2	In	33	DCOUTC	In
19, 20	N/C	N/A	34	N/C	N/A
21	DCSS1	In	35	DCSS2	In
22	N/C	N/A	36	N/C	N/A
23	DCIN1	In	37	DCIN9	In
24	DCIN2	In	38	DCIN10	In
25	DCIN3	In	39	DCIN11	In
26	DCIN4	In	40	DCIN12	In
27	DCIN5	In	41	DCIN13	In
28	DCIN6	In	42	DCIN14	In
29	DCIN7	In	43	DCIN15	In
30	DCIN8	In	44	DCIN16	In
31	DCOUTPWR1	In	Shell	Drain	In
32	DCOUTPWR2	In			

Table 11-3: General I/O Port to Flying Lead Cable

Part Number: M.1016.2567
 Length: 3 M (10 ft)
 Cable type: 28 AWG, shielded, twisted pair, 44 conductor.

44-Pin HD female D-sub (to Gen I/O Port, face view)

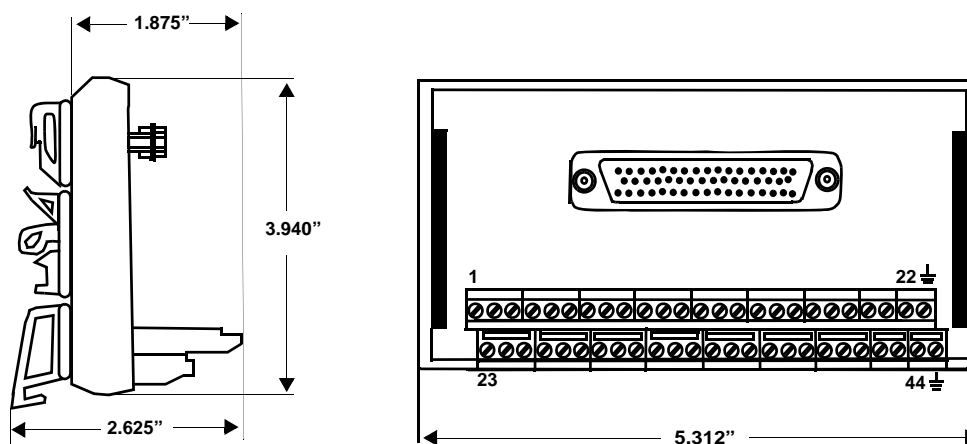


Pin	Signal	Color	Notes	Pin	Signal	Color	Notes
1	DCOUT1	Black	Twisted	22	None	Red	Twisted
2	DCOUT2	Red	Pair	23	DCIN1	Brown	Pair
3	DCOUT3	Black	Twisted	24	DCIN2	Red	Twisted
4	DCOUT4	White	Pair	27	DCIN5	Orange	Pair
5	DCOUT5	Black	Twisted	25	DCIN3	Green	Twisted
6	DCOUT6	Green	Pair	26	DCIN4	White	Pair
7	DCOUT7	Black	Twisted	28	DCIN6	Green	Twisted
8	DCOUT8	Blue	Pair	29	DCIN7	Blue	Pair
9	DCOUT9	Black	Twisted	31	DCOUTPWR1	Green	Twisted
10	DCOUT10	Yellow	Pair	32	DCOUTPWR2	Yellow	Pair
11	DCOUT11	Black	Twisted	33	DCOUTC	Green	Twisted
12	DCOUT12	Brown	Pair	34	None	Brown	Pair
13	DCOUT13	Black	Twisted	35	DCSS2	Green	Twisted
14	DCOUT14	Orange	Pair	36	None	Orange	Pair
15	DCOUT15	Red	Twisted	37	DCIN9	White	Twisted
30	DCIN8	White	Pair	38	DCIN10	Blue	Pair
16	DCOUT16	Red	Twisted	39	DCIN11	White	Twisted
17	DCOUTPWR1	Green	Pair	40	DCIN12	Yellow	Pair
18	DCOUTPWR2	Red	Twisted	41	DCIN13	White	Twisted
21	DCSS1	Blue	Pair	42	DCIN14	Brown	Pair
19	None	Red	Twisted	43	DCIN15	White	Twisted
20	None	Yellow	Pair	44	DCIN16	Orange	Pair
Shell	Drain	N/A					

Description	Length	Part Number
MMC Gen I/O Breakout Box	N/A	M.1016.2532
MMC Gen I/O & Aux I/O Connector to Breakout Box Cable	.3 M (1 ft)	M.1016.2539
MMC Gen I/O & Aux I/O Connector to Breakout Box Cable	.6 M (2 ft)	M.1016.2540
MMC Gen I/O & Aux I/O Connector to Breakout Box Cable	.9 M (3 ft)	M.1016.2541

a. The Breakout Box (see [Figure 11-2 on page 186](#)) is DIN-rail mounted, and provides screw terminal wire termination. It can be attached to the “GEN I/O” port on the MMC Control, and on the “GEN I/O A” and “GEN I/O B” ports on the MMC 32 In/32 Out Expansion module. The pinouts on the terminal strip interface provide a one-to-one transfer of the signals from the connector to the respective pin(s) on the terminal block. The connector pins marked with the “ground” symbol on the screw connector are connected to the “D” connector shell for shield grounding purposes.

Figure 11-2: General I/O Port Breakout Box Dimensions



11.2.1 DC Output Operation

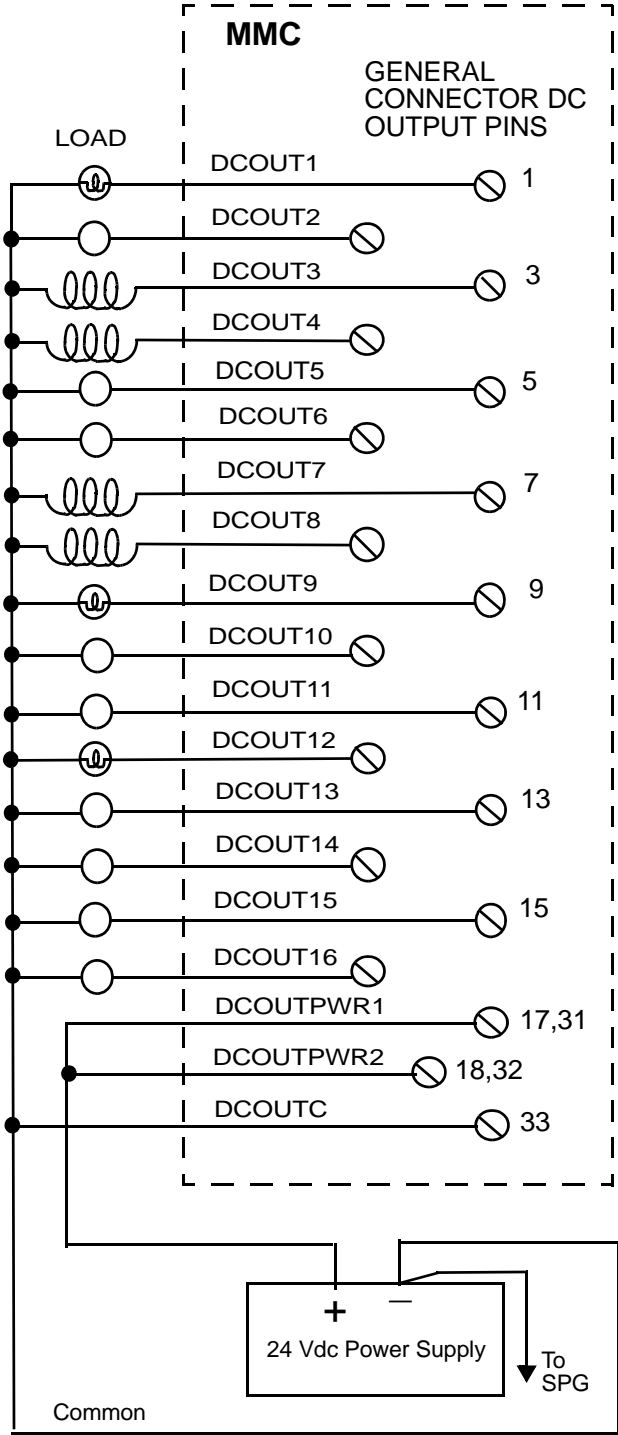
Each General I/O Port provides 16 source-only 24 Vdc outputs. Each of the 16 outputs on the general I/O connector is a solid state switch rated at 250 ma. An example of connecting the DC Outputs to loads is shown in [Figure 11-3](#).

Each port contains two groups of eight outputs: group A = output 1 through output 8, group B = output 9 through output 16. Each group is capable of detecting a short circuit or over-current condition. When a short circuit or over-current condition is sensed, all outputs in the group are turned off and remain off for approximately 100 ms regardless of ladder activity. After 100 ms, the ladder again controls the outputs. In addition, each output is protected with internal clamping diodes. Without clamping, high voltage transients (kickback) from inductive loads might damage the module.

For safety reasons, all outputs turn off (no current flow) when a scan loss condition occurs.

For more information on DC output operation, refer to [Section A.3 on page 206 of Appendix A](#).

Figure 11-3: Gen I/O Port Output Connections



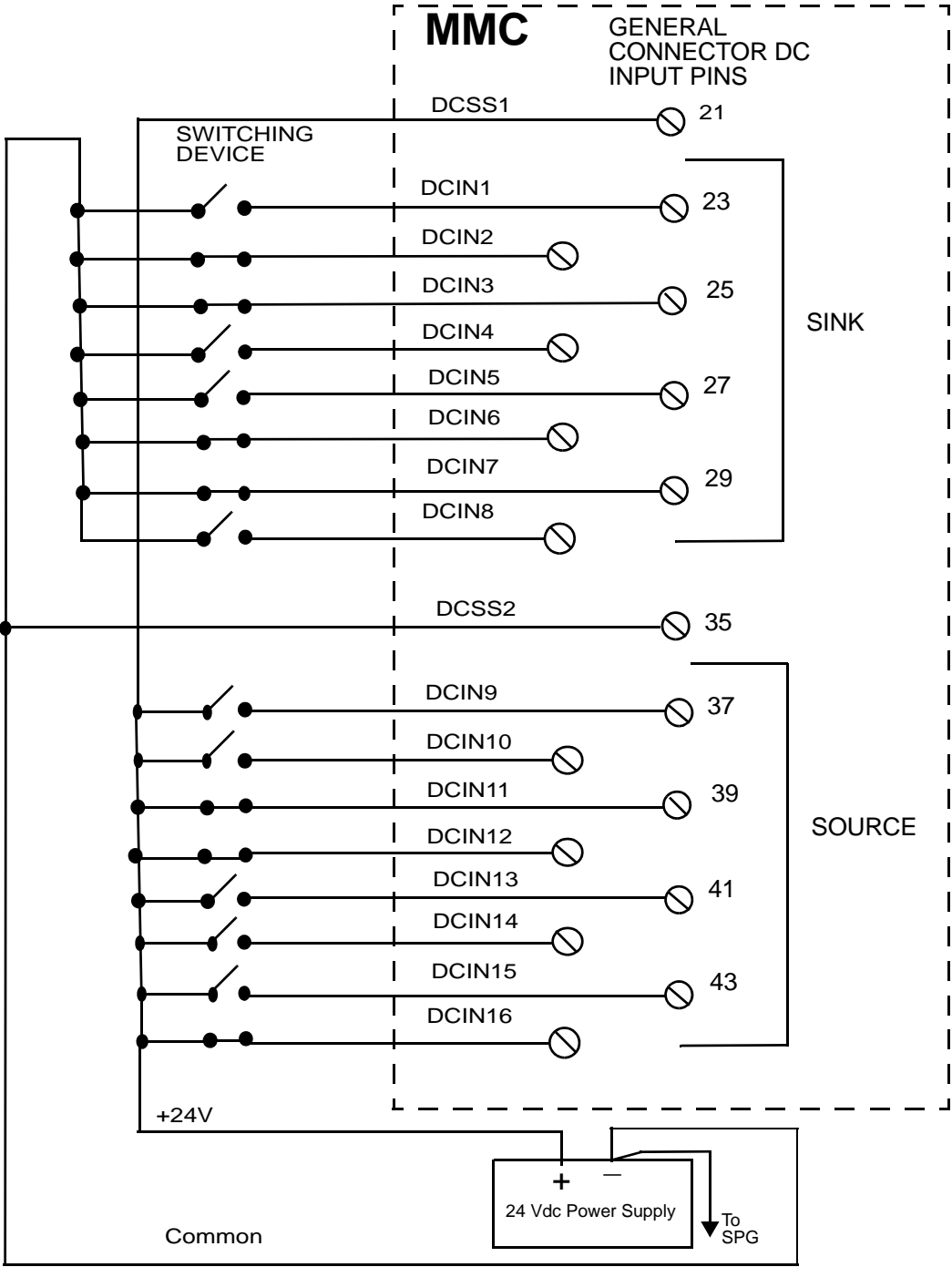
11.2.2 DC Input Operation

Each General I/O Port provides sixteen 24 Vdc inputs. Each Port contains two groups of eight inputs: group A = input 1 through output 8, group B = input 9 through output 16. Each group can be configured as sourcing or sinking. Connect the DCSS pin (DCSS1 for Group A, DCSS2 for Group B) to IO24C for a sourcing configuration. Connect the DCSS pin (DCSS1 for Group A, DCSS2 for Group B) to +24 Vdc for a sinking configuration. An example of connecting input devices in both a sink and source configuration is shown in [Figure 11-4](#).

In addition, the first input of each Group (Input 1 of Group A, and input 9 of Group B), can be programmed to provide a processor interrupt on either a low-to-high or high-to-low transition.

For more information on DC input operation, refer to [Section A.2 on page 205 of Appendix A](#).

Figure 11-4: General Input Connections



11.3 Specifications

Table 11-5: Specifications	
Part Number	M.3000.0043
Physical size	1.28" wide x 9.6" high x 5.3" deep 52.51 mm x 243.84 mm x 134.62 mm
DC Inputs	
Number of Inputs	32 Inputs (16 on each connector)
Configuration	On each of two connectors, the General Inputs are divided into two groups of eight. Each group can be configured for sourcing or sinking. Operates with IEC Type 1 inputs (per IEC 1131=2).
Input voltage	Nominal 24 VDC, maximum 30 VDC
Guaranteed on voltage	15 VDC
Guaranteed off voltage	5 VDC
Turn on/off time	1 ms
DC Outputs	
Number of Outputs	32 outputs (16 on each connector)
Input voltage	Nominal 24 VDC, 30 VDC maximum
Configuration	On each of two connectors, there are two groups of eight solid-state switches.
Protection of logic circuits	Optical isolation between the logic and field side, diode transient suppression protection provided.
Maximum current	250 ma per output
Voltage range	24 VDC nominal, 5 to 30 VDC
Switch characteristics	Solid-state switches
Time delay on for resistive loads	50 µsec max
Time delay off for resistive loads	50 µsec max
Leakage current in off state	0.5 mA max
Switch voltage, maximum ON	1 VDC max

Short circuit protection for each group (per Group of eight, and entire Group turns off)	15 A (max) pulses for 130 μ sec (nominal) every 100 msec until short is removed
Overload circuit protection trip point (each Output, and entire Group of eight turn off)	4 A for 5ms
Scan loss response	Outputs turn off
Environmental	
Operating temperature range	5°C to 55°C (41°F to 131°F)
Storage temperature range	-40°C to 85°C (-40°F to 185°F)
Humidity	5 to 95%, non-condensing
Vibration (per IEC 68-2-6)	10-57 Hz (constant amplitude = .15 mm) 57 - 2000 Hz (acceleration = 2 g)
Shock (per IEC 68-2-27)	Four shocks per axis (15g/11 msec)
CE Marked	<p>Conforms to Directives 73/23/EEC, 89/336/EEC, 92/31/EEC, 93/68/EEC by conforming to the following standards: EN 50081-2:1993EMC Generic Industrial Emissions EN 50082-2:1995EMC Generic Industrial Immunity EN 61131-2:1994/A11:1996 Low voltage directive requirements for programmable controllers Operates with emissions below EN55011/ CISPR 11 Class A limits Immune to:</p> <ul style="list-style-type: none"> • Electrostatic discharge (4K V contact mode, 8K V air discharge) per EN61000-4-2 • RF electromagnetic fields per EN61000-4-3, ENV 50141, and ENV50204 • Electrical fast transients per EN61000-4-4 • Magnetic fields per EN61000-4-8 <p>Refer to the EMC Guidelines for more information.</p>
UL and C/UL Listed	E126417

12 CE and EMC Guidelines

NOTE

The CE mark on PiC products assures compliance with both the EMC and low voltage European directives. Prior to this CE mark, EMC on the product label only assured compliance with the EMC directives.

12.1 Background on EMC (Electromagnetic Compatibility) Compliance

In order to market products in the European Union after January 1, 1996, an electromagnetic compatibility directive (EU Directive 89/336/ECC) must be met. All products must be designed and manufactured in such a way that:

- Electromagnetic disturbances generated by the products do not cause interference to other systems.
- The performance of the product is not affected by electromagnetic disturbances within the environment in which the product is intended to operate.

The directive refers to relevant harmonized European EMC standards against which product conformity can be assessed, although other methods of assessment, notably the preparation of a Technical File, are permissible. The equipment manufacturer or the manufacturer's agent in the Community must make a Declaration of Conformity and can place the CE mark on the product. Failure to conform with the requirements of the directive can result in a total ban on sales throughout the Single Market and legal action could be taken against the signatory of a false declaration of conformity.

12.2 Background on Low Voltage Compliance

In order to market products in the European Union after January 1, 1997, the low voltage directive (EU Directive 73/23/EEC) must be met.

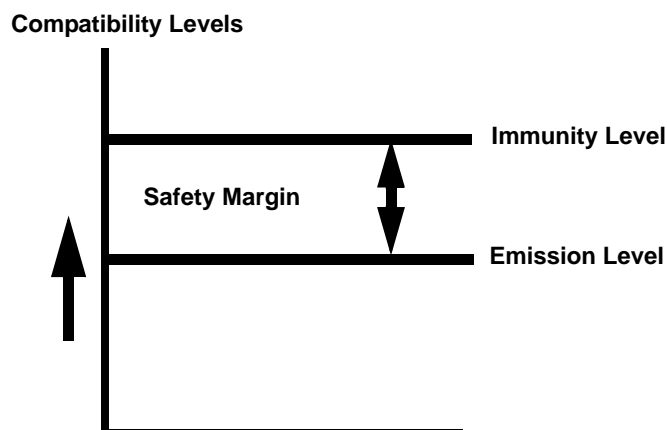
The intention of the directive is to assure user safety under normal operating and fault conditions. The directive includes the use of certain warning labels and user instructions. It establishes limits to prevent electrical shock hazard, overheating and fire.

12.3 RFI Emission and Immunity

The EMC product characteristics are classified by the emission and immunity performance.

Emissions not only include radiated noise from the product enclosure and cabling, but also that which is conducted away from the product along the cables connected to it. This may be subsequently radiated from the cable or conducted directly into another product which shares this cable e.g. the main AC supply.

Immunity is how susceptible a product is (e.g. to the radiated and conducted emissions from the product mounted next to it). To ensure compatibility, the immunity of a product must always exceed the expected emissions in the environment in which it operates as is shown in the diagram below. This is to ensure a margin of safety.

Figure 12-1: Safety Margin

In addition to conducted and radiated immunity, products must also be capable of withstanding:

- Electrostatic discharges (ESD)
- Conducted fast transient voltages

The discharge spark generated from ESD can easily damage electronic components. The conducted fast transient voltages are induced in cables laid in close proximity to other cables in which large inductive loads are switched (such as relays, contactors, and AC motor starters). This is a good example of what can happen to sensitive control and signal cabling connected to drives when poorly installed in enclosures on industrial sites.

12.4 Classes of EMC Operating Environments

Before the correct level of EMC can be designed into equipment, the EMC operating environment must be defined. For example in industrial locations where high power equipment is in use, high levels of background electrical noise would be expected when compared to a household or office environment. Since it is more expensive to reduce the emissions from higher power equipment than to increase the immunity, the emission limits allowed in industrial environments are higher than for household or office environments. Vice versa for immunity because of the higher emission limits in industrial environments, the immunity requirements are more strict than for the household or office environment. Hence in order to achieve EMC between different equipment, it is essential to know what EMC operating environment it is to be installed in, and to compare the installation environment to the environment for which it was designed.

Today using generic EMC standards, two environments are defined:

1. Industrial
2. Residential, commercial, and light industrial

The environments are locations defined on the basis of whether the AC supply is shared with other locations or is buffered from them with a distribution transformer. If your location is buffered via a distribution transformer, then you are in an industrial environment. If you share your AC supply with a neighboring location, then you are in

a residential, commercial, or light industrial environment. For example, an industrial unit which shares its AC supply with a neighboring unit is defined as a residential, commercial, and light industrial location. If it is supplied from its own distribution transformer, then it is an industrial location.

12.5 Conformance with the EMC Directive

Danaher Motion will be complying to the Directive by self-certification to the following generic EMC standards:

- EN50081-2 for industrial emissions using EN55011 (based upon CISPR 11A)
- EN50082-2 for industrial immunity using:
 - IEC 61000-4-2 (ESD- 4KV contact mode, 8 KV air discharge)
 - IEC 61000-4-3 (Radiated susceptibility)
 - IEC 61000-4-4 (Electrical fast transient)
 - IEC 6100-4-8 (Magnetic fields)

A statement of compliance will be made with the letters “EMC” or “CE” on the product, but will be valid only if the product is installed properly.

12.6 Conformance With the Low Voltage Directive

Danaher Motion will comply with the Directive by self certification to the following standard:

- EN 61131-2:1994/A11:1996 Low Voltage Requirements for Programmable Controllers

A statement of compliance will be made with the letters “CE” on the product but will be valid only if the equipment is properly installed.

12.7 Changes to the PiC Products

Danaher Motion PiC products had originally been designed with a high level of noise immunity and tested according to standards such as NEMA showering arc and the original version of IEC 801-2. However, the EU directive for immunity requires testing to standards that have more variables and are more repeatable. The directive also requires control of emissions, something that is not regulated in U. S. industrial environments.

As a result, changes have been made to the hardware modules within the PiC product line. The changes have included the addition of filtering, re-routing of foils and/or the addition of ground planes to printed circuit boards, use of some conductive enclosures, provision for shielded wires (see Note below) for peer-to-peer communication, and internal connection of SPG to field side connectors.

NOTE

A recommended shielded wire is Belden, 24 AWG (7X32), 9729

12.7.1 Changes Affecting the User

Many of the changes Danaher Motion has implemented are transparent to the user. However, there are some changes affecting user installation.

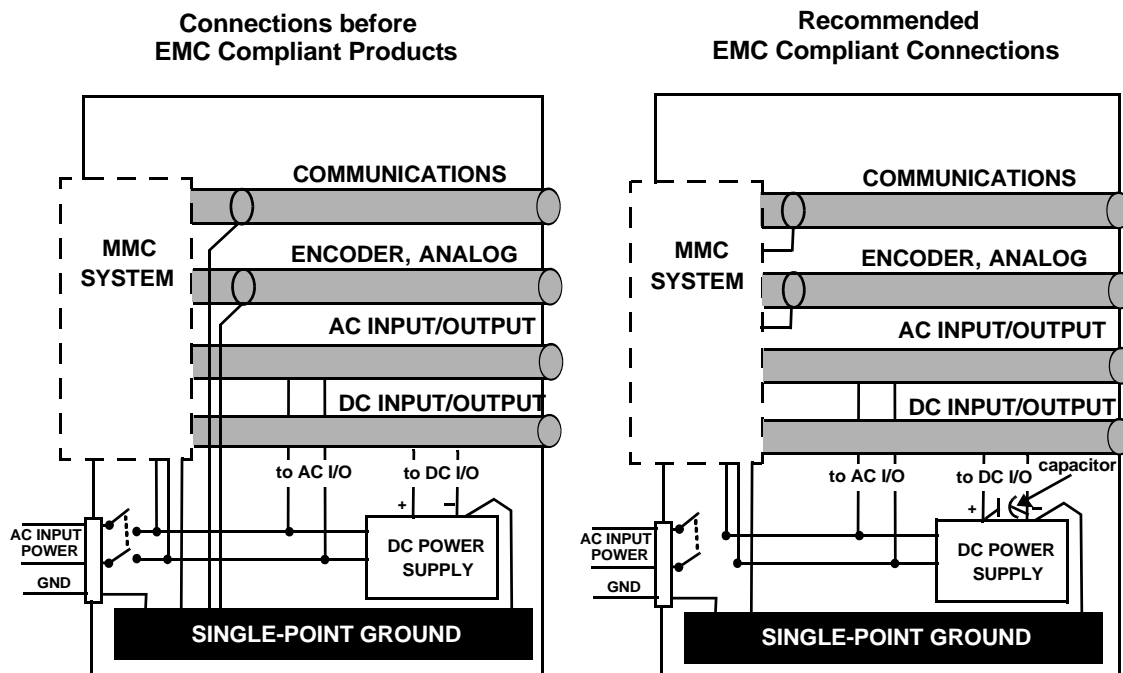
Danaher Motion continues to recommend separation of low level signals (encoder, analog, communications, fast DC inputs) from high voltage or high current lines from any of the above. More specifically, maintain *at least* one inch of separation around encoder signals and around communication signals.

It is no longer necessary to connect a wire from a module to SPG. This user-installed wire had been a source of emissions and thus the connection should not be made. Analog modules typically had this requirement in the past.

To prevent excessive conducted emissions from a DC power source (typically 24V) used for digital I/O, a 1000 picofarad capacitor should be used. Connect the capacitor from the +24V DC to COMMON at the distribution terminals. The same applies to any other external DC power source used with the PiC product.

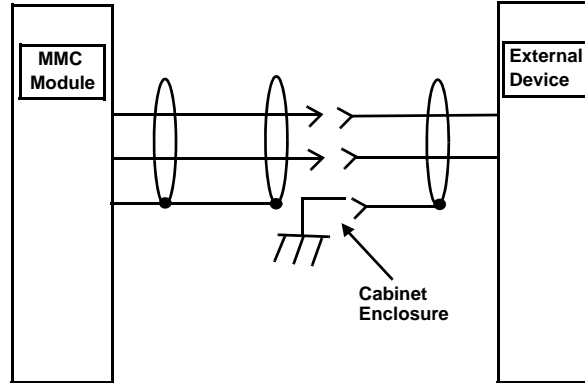
The figure on the left below illustrates the connection method *before* EMC compliant products were available. The figure on the right illustrates the recommended connections when using EMC compliant products. On the right, note that the SPG connection has been eliminated and that a capacitor is connected to the 24V DC supply.

Figure 12-2: Connections for EMC Compliance



There is now a provision for shield termination to the CPU modules for peer-to-peer communication. Shielded cable must be used to reduce emissions.

Inside a control cabinet, the practice of connecting the shields of shielded cables at the modules should be continued. For an example of a shielded cable entering/leaving the cabinet see [Figure 12-3 on page 197](#).

Figure 12-3: Connecting Shielded Cable

The two different methods of terminating shields are used to accommodate two different immunity requirements. Immunity required inside an enclosure is considered lower because cables are typically less than 3 meters in length and/or can be separated from each other and from noise sources.

Immunity required external to an enclosure is considered higher because the user may have less control over the noise environment. Low level signal cables that can be external to an enclosure and AC/DC digital I/O cables have been tested at a 2 KV level for electrical fast transients (EFTs). Low level signals that can be less than 3 meters in length or can be separated from noise sources are tested at a 1 KV level.

Under the stated conditions, there will be no disturbance of digital I/O, encoder, or stepper operation. For analog signals, there may be momentary disturbances but there will be self-recovery when the noise subsides.

In order to meet the EU directive requirement for emissions and immunity, fiber optics must be used for I/O expansion.

Although the control will pass the electrical fast transient test on incoming power lines, users may still want to use a power line conditioner.

As a general precaution, do not operate transmitters, arc welding equipment, or other high noise radiators within one meter of a PiC enclosure that has the door open. Continue to equip inductive devices, if they are in series with a mechanical contact or switch, with arc suppression circuits. These devices include contactors, solenoids and motors. Shield all cables that carry heavy current near the system, using continuous foil wrap or conduit grounded at both ends. Such cables include power leads for high-frequency welders and for pulse-width-modulated motor drives.

NOTE

Shields for signal wires are grounded at only one end, to provide immunity to outside noise sources. However, the shields for "noise sources" are grounded at both ends, to reduce emissions and "contain" the noise.

Worst case tests with analog I/O modules have caused momentary disturbances no greater than .5V in a +10V to -10V range and .5 mA in a 4 to 20 mA range. Worst case tests with an RTD module have caused momentary disturbances no greater that + or -

4°C in a range of -200° to 266°C. Worst case tests with a JK thermocouple module have caused momentary disturbances no greater than + or - 1 mV over a 100 to 1.

NOTE

To assure compliance with the low voltage directive, it is necessary to follow installation instructions in the controller Hardware Manual. Also refer to any instructions specific to individual control modules.

12.8 Using CE/EMC and Non-CE/EMC Modules

IMPORTANT

Failure to follow these guidelines may result in undesired system performance.

NOTE

CE indicates compliance to both the EMC and low voltage directives. EMC indicates compliance to the EMC directive.

There are several issues that must be considered when using CE/EMC compliant and Non-CE/EMC compliant Modules. This document addresses these issues.

Module Identification - To determine whether a module is CE/EMC or Non-CE/EMC, look at the gray Unit Tag located on the side of the plastic module case. CE/EMC modules will have “CE” or “EMC” printed near the “MAX. AMBIENT TEMP.” specification. Non-CE/EMC will not have “CE” or “EMC” printed in this location.

Grounding - Due to differences in shielding requirements, it is extremely important to follow proper shielding guidelines for a given module. Failure to do so may result in intermittent operation in noisy environments.

For modules that have an SPG terminal and/or one or more SHIELD terminal, perform the following:

- For CE/EMC modules, do not connect the SPG terminal or SHIELD terminals to the system’s Single Point Ground
- For Non-CE/EMC modules, connect the SPG terminal, or a SHIELD terminal, to the system’s Single Point Ground

CE/EMC CSM and RSM Modules - Using a CE/EMC CSM, RSM, or CSM/CPU (PiC90) with certain Non-CE/EMC analog modules may cause intermittent operation. Follow these guidelines for determining the type of CSM, RSM, or CSM/CPU that should be used in a particular rack:

- If your rack contains one or more Non-CE/EMC modules that perform D/A conversion or provide an Encoder interface, you must use a non-CE/EMC CSM, RSM, or CSM/CPU (PiC90).
- If your rack contains one or more Non-CE/EMC modules that perform D/A conversion or provide an Encoder interface, you must use a non-CE/EMC CSM, RSM, or CSM/CPU (PiC90).

- If your rack does not contain one or more Non-CE/EMC modules that perform D/A conversion or provide an Encoder interface, you may use either a CE/EMC or Non-CE/EMC CSM, RSM, or CSM/CPU (PiC90).

NOTE

For a system to be CE/EMC compliant, all modules and backplanes must be CE/EMC compliant

12.9 Declarations of Conformity

The undersigned, representing the supplier

G & L Motion Control Inc.
672 South Military Road
Fond du Lac, Wisconsin 54936-1960

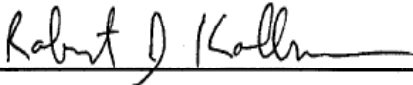
herewith declares that all **PiC900™/PiC90™/PiC9™/MMC and Block I/O modules**, labeled with the CE mark, are in conformity with the provisions of the following EC Directives when installed in accordance with the installation instructions contained in the product documentation:

Low Voltage Directive 73/23/EEC as amended by 93/68/EEC
EMC Directive 89/336/EEC as amended by 92/31/EEC and 93/68/EEC

Conformity of the specified product is based upon application of the following standards and/or technical specifications referenced below:

<i>EN 50081-2:1993</i>	<i>EMC Generic Industrial Emissions</i>
<i>EN 50082-2:1995</i>	<i>EMC Generic Industrial Immunity</i>
<i>EN 61131-2:1994/A11:1996</i>	<i>Low voltage requirements for programmable controllers</i>
<i>EN61326:1997</i>	<i>Electrical Equipment for measurement, control and Laboratory use – EMC requirements</i>

Year of Marking: 2002

<i>Signature</i>	
<i>Full Name</i>	Robert J. Kollmeyer
<i>Position</i>	Director of Engineering
<i>Place</i>	G & L Motion Control Inc.
<i>Date</i>	05-APR-05

EC DECLARATION OF CONFORMITY

The undersigned, representing the supplier

**G & L Motion Control Inc.
672 South Military Road
Fond du Lac, Wisconsin 54936-1960**

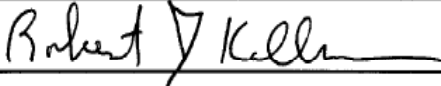
herewith declares that all **three-phase current synchronous motors, type MSM** are in conformity with the provisions of the following EC Directive when installed in accordance with the installation instructions contained in the product documentation:

Low Voltage Directive 73/23 EWG

Conformity of the specified product with the guidelines of this directive will be proved by the total compliance with the following harmonic European standards:

EN 60034-1: November 1995 Rotating Electrical Machines
EN 60034-5: April 1998
EN 60034-9: May 1996

Year of Marking: 1999

<i>Signature</i>	
<i>Full Name</i>	Robert J. Kollmeyer
<i>Position</i>	Director of Engineering
<i>Place</i>	G & L Motion Control Inc.
<i>Date</i>	05 - APR - 05

EC DECLARATION OF CONFORMITY

The undersigned, representing the supplier

G & L Motion Control Inc.
672 South Military Road
Fond du Lac, Wisconsin 54936-1960

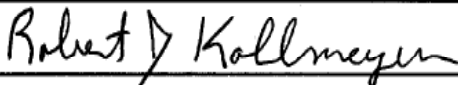
herewith declares that all **three-phase current synchronous motors, type LSM** are in conformity with the provisions of the following EC Directive when installed in accordance with the installation instructions contained in the product documentation:

Low Voltage Directive 73/23 EWG

Conformity of the specified product with the guidelines of this directive will be proved by the total compliance with the following harmonic European standards:

EN 60034-1: September 2000 Rotating Electrical Machines
+A11 May 2002
EN 60034-5: December 2001
EN 60034-9: June 1998

Year of Marking: 2002

<i>Signature</i>	
<i>Full Name</i>	Robert J. Kollmeyer
<i>Position</i>	Director of Engineering
<i>Place</i>	G & L Motion Control Inc.
<i>Date</i>	05-APR-05

EC DECLARATION OF CONFORMITY

The undersigned, representing the supplier

**G & L Motion Control Inc.
672 South Military Road
Fond du Lac, Wisconsin 54936-1960**

herewith declares that all **MMC Smart Drives (MMC-SD-XXX-230-XXX, MMC-SD-XXX-460-XXX) and accessories** are in conformity with the provisions of the following EC Directive(s) when installed in accordance with the installation instructions contained in the product documentation:

<i>73/23/EEC</i>	<i>Low Voltage Directive as amended by 93/68/EEC</i>
<i>89/336/EEC</i>	<i>EMC Directive as amended by 92/31/EEC and 93/68/EEC</i>

and that the standards and/or technical specifications referenced below have been applied:

<i>EN 50178:1998</i>	<i>Electronic equipment for use in power installations</i>
<i>EN 61800-3:1996</i>	<i>Adjustable speed electrical power drive systems – EMC</i>
<i>/A11:2000</i>	<i>product standard including specific test methods</i>

Year of Marking: 2003

<i>Signature</i>	<i>Robert J. Kollmeyer</i>
<i>Full Name</i>	Robert J. Kollmeyer
<i>Position</i>	Director of Engineering
<i>Place</i>	G & L Motion Control Inc.
<i>Date</i>	<i>05-APR-05</i>

Appendix A - Operation Details

A.1 Introduction

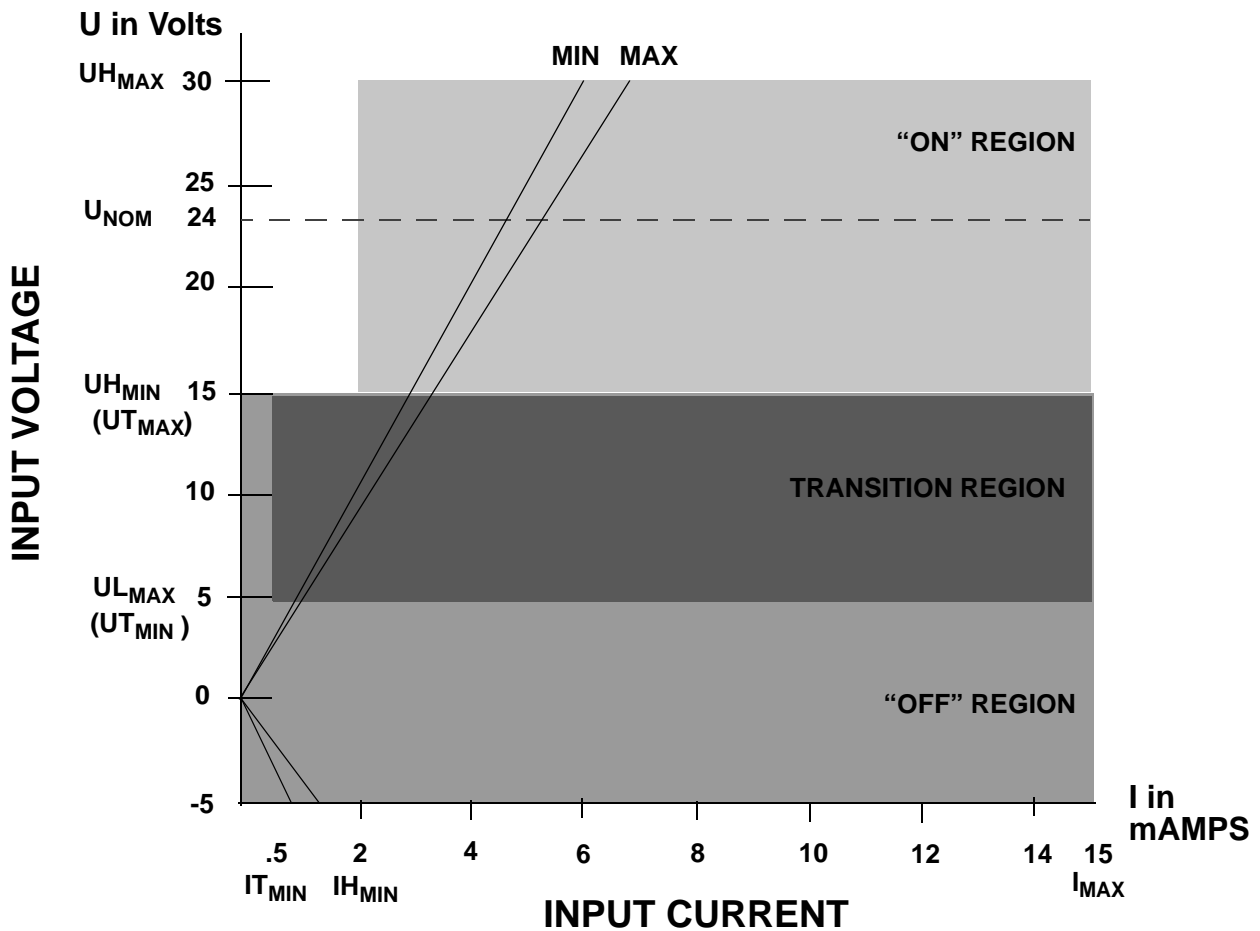
This appendix describes in detail the operation of many of the sub-systems found within the MMC Control and Option Modules.

A.2 DC Inputs

Each input is guaranteed “on” at 14 to 30 VDC and guaranteed “off” at 0 to 5 VDC (polarity doesn't matter). Its on/off state is converted to a corresponding logic 1 or 0. This logic state is transmitted through the system bus to the application program, which uses these logic states to control program flow. The logic side of the input is optically isolated from the field side.

The shaded blocks in [Figure A-1](#) below show the limits specified by the IEC. The lines show the maximum and minimum V/I of the inputs in this module. The voltage/current curve in this graph shows that the input module is well within the IEC Type 1 limits.

Figure A-1: Input Characteristics Compared to IEC Standards



IMPORTANT

Switching devices can sometimes have a leakage current that exceeds the $I_{T_{min}}$ (current allowed when off) of an input module. In order to use such a device, an impedance (typically, a resistor) needs to be used in parallel with the input.

For example, some of the newer proximity switches use two wires instead of three. The third wire was used for a power or ground line. Without the third wire, the switch is easier to install. However, it requires more leakage current in the off state to power its internal circuitry.

As a conservative estimate, use the following formula to calculate an external resistance value. It keeps the input voltage at or below 2.4V when the switching device is in the "off" state.

$$\frac{2.4V}{\text{Switch Leakage} - 0.75mA} \geq R$$

If the switch leakage specification is ≤ 1.7 mA, then:

$$\frac{2.4V}{1.7 - 0.75mA} \geq 2.5K\Omega$$

Use a resistor less than or equal to 2.5 K Ω . Be sure that the wattage is adequate for the resistor when the switching device is in the "on" state remembering that:

$$P = \frac{V_{ON}^2}{R}$$

A.3**DC Outputs**

A DC Output consists of a solid state switch. It turns on or off according to the logic state sent to it by the application program. If the application program sends it a logic 1, the switch closes and the device is powered. If the application program sends a logic 0, the switch opens and power to the device is cut off. The application program updates the logic state for each switch every time it scans the program.

The logic side of the switch is optically isolated from the field side. If you need to know whether voltage is actually present at the field side, use a voltmeter.

A.3.1**Inductive Loads**

Resistive and inductive loads can be connected to DC outputs and controlled by the system with no precautions other than making sure they have a connection to the common of the DC power supply.

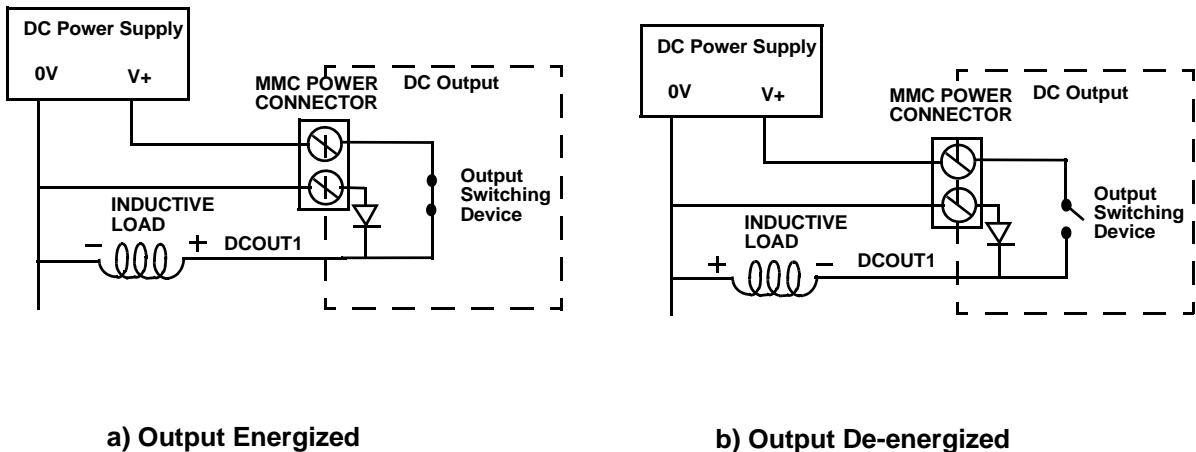
Inductive loads have an electrical "kickback" when current is stopped. This can damage or destroy the output switching device. Each output has a diode through which reverse current can be safely routed.

The internal diode works with an inductive load. When an output is energized, represented by a closed switch, current passes through the load into the common line. When the output is de-energized, represented by an open switch, current stops and the inductive field collapses. The state of the outputs is controlled by the CPU. This creates a reverse voltage across the load called "kickback" which tries to continue the

current. The voltage is in series with the DC power supply. The combined voltage appears across the output switching device in the module.

If this were the only path available, voltage across the device would peak at several hundred volts. The internal diode provides another path for current. This limits the peak reverse voltage across the load to less than 1 V. Every DC output has this protection so an inductive load can be connected safely.

Figure A-2: Diagram of Internal Protection for Inductive Loads



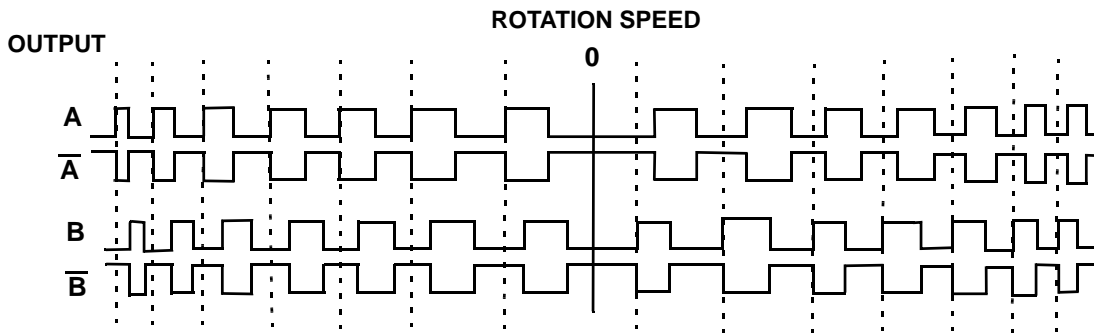
A.4 Encoder Inputs

The encoder inputs use differential type inputs to interface with incremental encoders. These inputs accept RS422 level quadrature signals. Recommended encoder drivers include 7272, 75183, 8830, 75114, 9614, 26LS31 (or equivalent).

A *quadrature encoder* sends square wave type signals. When the shaft rotates at a constant velocity, the A and B outputs are square waves and are at the same frequency. However they are out of phase with each other by 90° . When the encoder shaft rotates in one direction, each A pulse leads the corresponding B pulse by 90° . When it rotates the other direction each A pulse lags its B pulse by 90° .

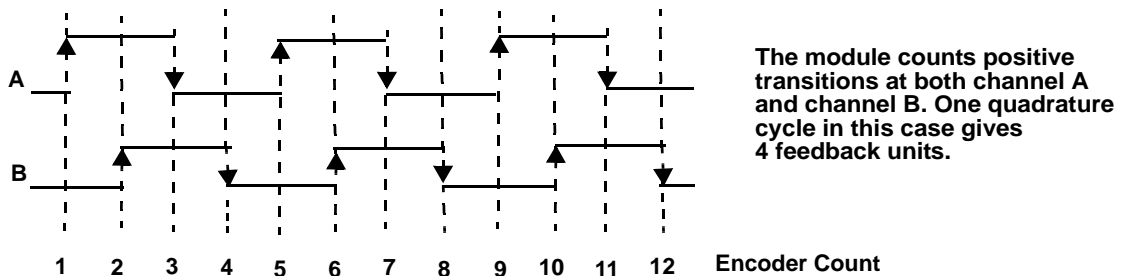
The signals illustrated in [Figure A-3](#) below indicate that the encoder shaft rotates in one direction at first. Its speed of rotation decreases to 0 and then it starts rotating the other direction. The signals are shown as differential. \bar{A} is the inverse of the signal A and \bar{B} is the inverse of signal B.

Figure A-3: Signals Transmitted by a Quadrature Encoder with Differential Outputs



The maximum input frequency is 250,000 lines per second, which results in 1,000,000 Feedback Units (FUs) per second.

Figure A-4: Counting Quadrature Pulses



There is a 24-bit up/down counter for each channel. It is incremented or decremented on each A, B edge. There is also a 24-bit latch associated with each encoder channel.

The module can be programmed so that the counter value is “latched” or stored under one of these conditions:

- an index pulse from the encoder
- a positive or negative transition of the fast input
- the next index pulse after the required transition of the fast input

Each of the five 24-bit latches has a *fast 24 VDC input* associated with it. Each input is optically isolated. This input is intended to receive a signal from a device other than an encoder. It is typically used for referencing or synchronization purposes.

Fast input characteristics include:

- the detection of a signal occurs faster than it does for the DC inputs in other modules, due to less filtering. Because of this there is also less noise immunity.
- the response to a fast input signal is independent of ladder scan time. The module can be programmed to latch a position count as soon as this input is detected.

Index

Numerics

- 32In/32Out module [181](#)
 - DC input operation [189](#)
 - DC output operation [186](#)
 - front view [182](#)
 - general I/O port [182](#)
 - introduction [181](#)
 - specifications [191](#)

A

- analog input
 - aux I/O port [85](#)
- analog motion [64](#)
- analog motion connections
 - Standalone MMC Control [64](#)
- analog motion operation
 - Standalone MMC Control [64](#)
- analog output
 - axis I/O port [72](#)
- analog servo board
 - Standalone MMC Control [38](#)
- application
 - starting [28](#)
 - wiring [26](#)
- aux I/O port
 - analog input [85](#)
 - DC inputs [83](#)
 - encoder inputs [84](#)
 - fast inputs [81](#)
 - Standalone MMC Control [74](#)
- Axis I/O module [175](#)
 - front view [176](#)
 - specifications [177](#)
- axis I/O port
 - analog output [72](#)
 - DC input [71](#)
 - DC outputs [69](#)
 - encoder input [73](#)
- axis I/O ports
 - Standalone MMC Control [64](#)

B

- battery
 - status light [31](#)
- battery replacement
 - in Standalone MMC Control [29](#)
- block I/O port
 - MMC-DSAXX Control [126](#)
 - Standalone Digital MMC Control [98](#)
 - Standalone MMC Control [45](#)

- breakout box
 - isolated encoder [79](#)

C

- CE guidelines [193](#)
 - codes
 - diagnostic error [32](#)
 - com ports
 - Ethernet module [155](#)
 - Compliance
 - to low voltage directive [193](#)
 - configuration port
 - DeviceNet module [165](#)
 - Profibus module [171](#)
 - conformance
 - EMC directive [195](#)
 - low voltage directive [195](#)
 - conformity
 - declaration of [200](#)
 - connections
 - DeviceNet module [164](#)
 - Ethernet module [151](#)
 - for EMC compliance [196](#)
 - MMC-DSAXX Control [122](#)
 - Profibus module [170](#)
 - SERCOS motion [85](#)
 - Standalone Digital MMC Control [97](#)
 - contents
 - manual [9](#)
 - control cabinet
 - specifications [22](#)
- ## D
- DC inputs
 - aux I/O port [83](#)
 - axis I/O port [71](#)
 - operation
 - 32In/32Out module [189](#)
 - general [205](#)
 - MMC-DSAXX Control [145](#)
 - Standalone MMC Control [62](#)
 - DC outputs
 - axis I/O port [69](#)
 - general operation [206](#)
 - inductive loads [206](#)
 - operation
 - 32In/32Out module [186](#)
 - MMC-DSAXX Control [143](#)
 - Standalone MMC Control [59](#)
 - declaration of conformity [200](#)
 - DeviceNet module [163](#)
 - configuration port [165](#)
 - connections [164](#)

- DeviceNet port [165](#)
 - front view [163](#)
 - introduction [163](#)
 - lights [166](#)
 - operation [166](#)
 - specifications [168](#)
- DeviceNet port
 - DeviceNet module [165](#)
- diagnostics
 - error codes [32](#)
 - power-up [31](#)
 - run-time [32](#)
 - status light (D) [31](#)
- differential signals
 - advantages of [28](#)
 - analog & encoder [27](#)
- digital link ports
 - MMC-DSAXX Control [136](#)
 - Standalone Digital MMC Control [112](#)
- dimensions
 - MMC option module [20](#)
- E**
- electrical service & maintenance safety [14](#)
- electro-static discharge [194](#)
- EMC
 - modules [198](#)
 - operating environments [194](#)
 - PiC products [195](#)
 - wiring guidelines for [26](#)
- EMC directive
 - conformance [195](#)
- EMC guidelines [193](#)
- encoder input
 - aux I/O port [84](#)
 - axis I/O port [73](#)
- encoder inputs
 - general operation [207](#)
- environmental requirements
 - general [21](#)
- error codes [32](#)
- ESD [194](#)
- Ethernet module [151](#)
 - com ports [155](#)
 - connections [151](#)
 - Ethernet port
 - specifications [152](#)
 - firmware update [158](#)
 - front view [151](#)
 - introduction [151](#)
 - lights [157](#)
 - operations [158](#)
 - specifications [160](#)
 - useful Internet links [161](#)

- Ethernet port
 - MMC-DSAXX Control [124](#)
 - Standalone Digital MMC Control [110](#)

F

- fast inputs
 - aux I/O port [81](#)
- fast transient voltage [194](#)
- features
 - MMC DSAXX Control [119](#)
 - Standalone Digital MMC Control [95](#)
 - Standalone MMC Control [35](#)
- firmware update
 - Ethernet module [158](#)
- front view
 - 32In/32Out module [182](#)
 - Axis I/O module [176](#)
 - DeviceNet module [163](#)
 - Ethernet module [151](#)
 - MMC-DSAXX Control [121](#)
 - Profibus module [169](#)
 - Standalone Digital MMC Control [96](#)
 - Standalone MMC Control [37](#)

G

- general I/O port
 - 32In/32Out module [182](#)
 - MMC-DSAXX Control [138](#)
 - Standalone MMC Control [55](#)
- ground
 - single point [24](#)
- grounding
 - protective earth [12](#)
 - system [23](#)
- guidelines
 - CE [193](#)
 - EMC [193](#)

H

- handling components [25](#)
- heat
 - controlling in system [24](#)

I

- inductive loads
 - DC outputs [206](#)
- inspection
 - safety [13](#)
- installation
 - MMC Control [17](#)
- introduction
 - 32In/32Out module [181](#)
 - DeviceNet module [163](#)

Ethernet module [151](#)
 MMC-DSAXX Control [119](#)
 Profibus module [169](#)
 Standalone Digital MMC Control [95](#)
 Standalone MMC Control [9](#)
 isolated encoder breakout box [79](#)

L

lights

battery status [31](#)
 DeviceNet module [166](#)
 diagnostic status (D) [31](#)
 Ethernet module [157](#)
 power status (P) [31](#)
 Profibus module [172](#)
 scan status (S) [31](#)
 system status [31](#)

loader port

SERCOS motion board [87](#)

low voltage directive

conformance [195](#)

M

machine control board

Standalone MMC Control [38](#)

machine control operation

Standalone MMC Control [43](#)

maintenance

MMC Control [17](#)
 procedure [28](#)

manual

contents [9](#)

manual cleaning procedure [15](#)

manuals

required [9](#)
 suggested [10](#)

MMC DSA-XX Control

features [119](#)

MMC option module

dimensions [20](#)
 mounting [18](#)

MMC-DSAXX

mounting [17](#)

MMC-DSAXX Control

block I/O port [126](#)
 connections [122](#)
 DC input operation [145](#)
 DC outputs operation [143](#)
 digital link ports [136](#)
 Ethernet port [124](#)
 front view [121](#)
 general I/O port [138](#)
 introduction [119](#)

operation [122](#)

overview [119](#)

PiCPro port [123](#)

power connector [147](#)

power supply requirements [122](#)

specifications

MMC-DSAXX Control [148](#)

user port [130](#)

motion control board

Standalone MMC Control [38](#)

mounting

MMC option module [18](#)

MMC-DSAXX [17](#)

Standalone MMC Control [17](#)

Standalone MMC Digital Control [17](#)

O

operation

DC inputs [205](#)

DC outputs [206](#)

DeviceNet module [166](#)

encoder inputs [207](#)

Ethernet module [158](#)

MMC Control [17](#)

MMC-DSAXX Control [122](#)

Profibus module [172](#)

safety [14](#)

SERCOS motion [85](#)

Standalone Digital MMC Control [97](#)

overview

MMC-DSAXX Control [119](#)

Standalone Digital MMC Control [95](#)

Standalone MMC Control [35](#)

P

part numbers

Standalone Digital MMC Control [116](#)

Standalone MMC Control [90](#)

PiCPro port

MMC-DSAXX Control [123](#)

Standalone Digital MMC Control [108](#)

Standalone MMC Control [43](#)

power connector

MMC-DSAXX Control [147](#)

Standalone Digital MMC Control [114](#)

Standalone MMC Control [64](#)

power distribution diagram [22](#)power light (P) [31](#)

power requirements

general [21](#)

power supply requirements

MMC-DSAXX Control [122](#)

Standalone Digital MMC Control [96](#)

- Standalone MMC Control [39](#)
- power-up diagnostics [31](#)
- procedure
 - maintenance [28](#)
 - manual cleaning [15](#)
- Profibus module [169](#)
 - configuration port [171](#)
 - connections [170](#)
 - front view [169](#)
 - introduction [169](#)
 - lights [172](#)
 - operation [172](#)
 - Profibus port [171](#)
 - specifications [174](#)
- Profibus port
 - Profibus module [171](#)
- protective earth
 - grounding [12](#)

R

- RFI
 - emission [193](#)
 - immunity [193](#)
- run-time diagnostics [32](#)

S

- safety
 - after shutdown [13](#)
 - cleaning [15](#)
 - electrical service & maintenance [14](#)
 - inspection [13](#)
 - operating safely [14](#)
 - operation [14](#)
 - signs [12](#)
 - system [11](#)
 - warning labels [12](#)
- Sales and Service [214](#)
- scan status light (S) [31](#)
- separation
 - signal [26](#)
- SERCOS
 - loader port [87](#)
- SERCOS board
 - Standalone MMC Control [39](#)
- Service [214](#)
- signals
 - analog [27](#)
 - differential [27](#)
 - encoder [27](#)
 - separation [26](#)
- signs
 - safety [12](#)
- single point ground [23](#)

- single point ground (SPG)
 - checklist [24](#)
- software
 - required [9](#)
- specifications [191](#)
 - 32In/32Out module [191](#)
 - Axis I/O module [177](#)
 - control cabinet [22](#)
 - DeviceNet module [168](#)
 - Ethernet module [160](#)
 - Ethernet module Ethernet port [152](#)
 - Profibus module [174](#)
 - Standalone Digital MMC Control [116](#)
 - Standalone MMC Control [90](#)
- Standalone Digital MMC Control [95](#)
 - block I/O port [98](#)
 - connections [97](#)
 - digital link ports [112](#)
 - Ethernet port [110](#)
 - features [95](#)
 - front view [96](#)
 - introduction [95](#)
 - mounting [17](#)
 - operation [97](#)
 - overview [95](#)
 - part numbers [116](#)
 - PiCPro port [108](#)
 - power connector [114](#)
 - power supply requirements [96](#)
 - specifications [116](#)
 - user port [102](#)
- Standalone MMC Control [35](#)
 - analog motion
 - connections [64](#)
 - operation [64](#)
 - analog servo board [38](#)
 - aux I/O port [74](#)
 - analog input [85](#)
 - DC inputs [83](#)
 - encoder input [84](#)
 - fast inputs [81](#)
 - axis I/O port [64](#)
 - analog output [72](#)
 - DC inputs [71](#)
 - DC outputs [69](#)
 - encoder input [73](#)
 - battery replacement [29](#)
 - block I/O port [45](#)
 - DC input operation [62](#)
 - DC output operation [59](#)
 - features [35](#)
 - front view [37](#)
 - general I/O port [55](#)
 - introduction [9](#)

- machine control board [38](#)
 - connections [43](#)
 - operation [43](#)
 - motion control board [38](#)
 - mounting [17](#)
 - overview [35](#)
 - part numbers [90](#)
 - PiCPro port [43](#)
 - power connector [64](#)
 - power supply requirements [39](#)
 - SERCOS board [39](#)
 - SERCOS loader port [87](#)
 - SERCOS motion
 - connections [85](#)
 - operation [85](#)
 - specifications [90](#)
 - user port [49](#)
 - starting
 - an application [28](#)
 - status lights [31](#)
 - system
 - controlling heat [24](#)
 - grounding [23](#)
- T**
- technical support contacts [10](#)
- U**
- user port
 - MMC-DSAXX Control [130](#)
 - Standalone Digital MMC Control [102](#)
 - Standalone MMC Control [49](#)
- V**
- voltage
 - fast transient [194](#)
- W**
- warning label
 - danger, warning, caution [13](#)
 - hazard [12](#)
 - Web Address [214](#)
 - wiring
 - application [26](#)
 - EMC compliant [26](#)
 - for EMC compliance [196](#)
 - guidelines [26](#)

Sales and Service

We are committed to quality customer service. In order to serve in the most effective way, please contact your local sales representative for assistance.

If you are unaware of your local sales representative, please contact us.

North America

Danaher Motion Customer Support North America

E-mail: glmotion.support@danahermotion.com
Phone: In the United States, telephone (800) 558-4808
Outside the United States, telephone (920) 921-7100
Fax: (920) 906-7669
Web site: www.glcontrols.com

Europe

Danaher Motion Customer Support Europe

E-mail: glmotion.support@danahermotion.com
Phone: +44 (0)1525 243-243
Fax: +44 (0)1525 243-244
Web site: www.glcontrols.com

