

- NOTES:
- SIZE 17 PITCH HARMONIC GEAR WITH 101:1 RATIO
 - THE FOLLOWING PARTS (SOLD AS SEPARATE KIT) ARE REQUIRED FOR CONNECTION TO ANOTHER JOINT OF THE SAME SIZE TO ENSURE IP RATING:
 - (1) PLASTIC SEAL RING
 - (1) RUBBER SEAL BAND
 - (16) M3X0.5 X 6MM LONG SOCKET HEAD CAP SCREWS
 - TORQUE M3 SCREWS IN OUTPUT PLATE TO 1.8Nm [16 IN-LB] AND USE REMOVABLE THREADLOCKER ON SCREWS.
 - CAN CONNECTOR: TE CONNECTIVITY 5-292271-2
 - POWER FERRULES: PHOENIX 3201576
 - SEE RGM USER MANUAL FOR ELECTRICAL CONNECTIONS.

REVISION HISTORY				
REV	ECO NUMBER	DESCRIPTION	DATE	APP'D
A	R03_99598	SEE ECO	04/12/19	BW
B	R03_99639	CORRECTED CONNECTORS SEE ECO	04/17/19	BW

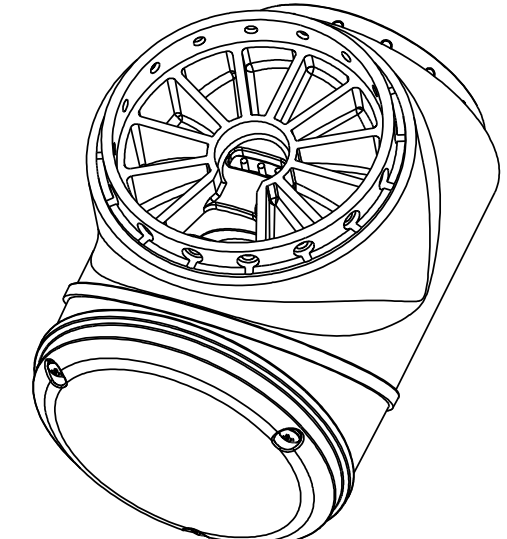
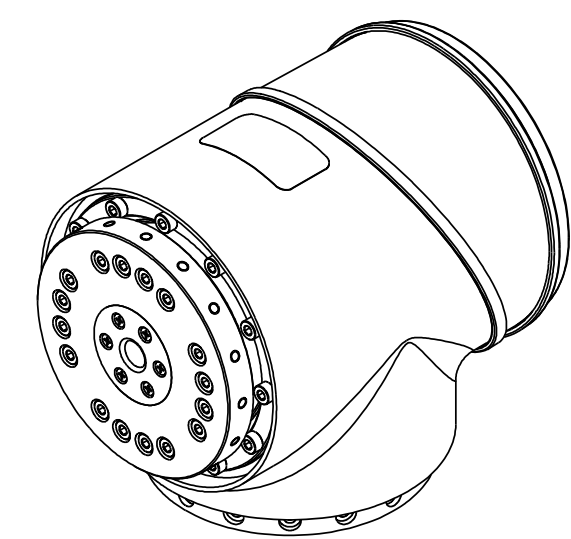
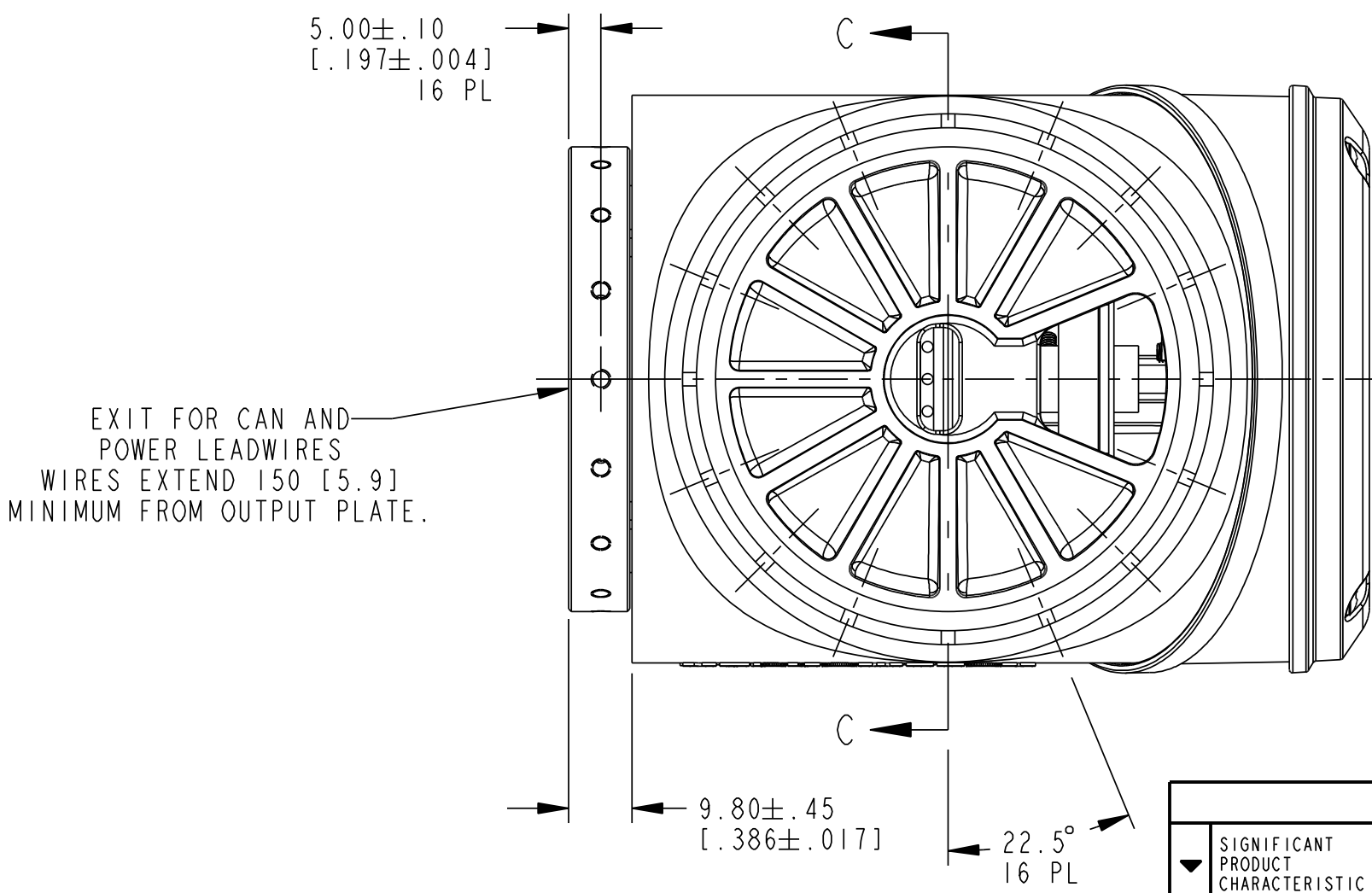
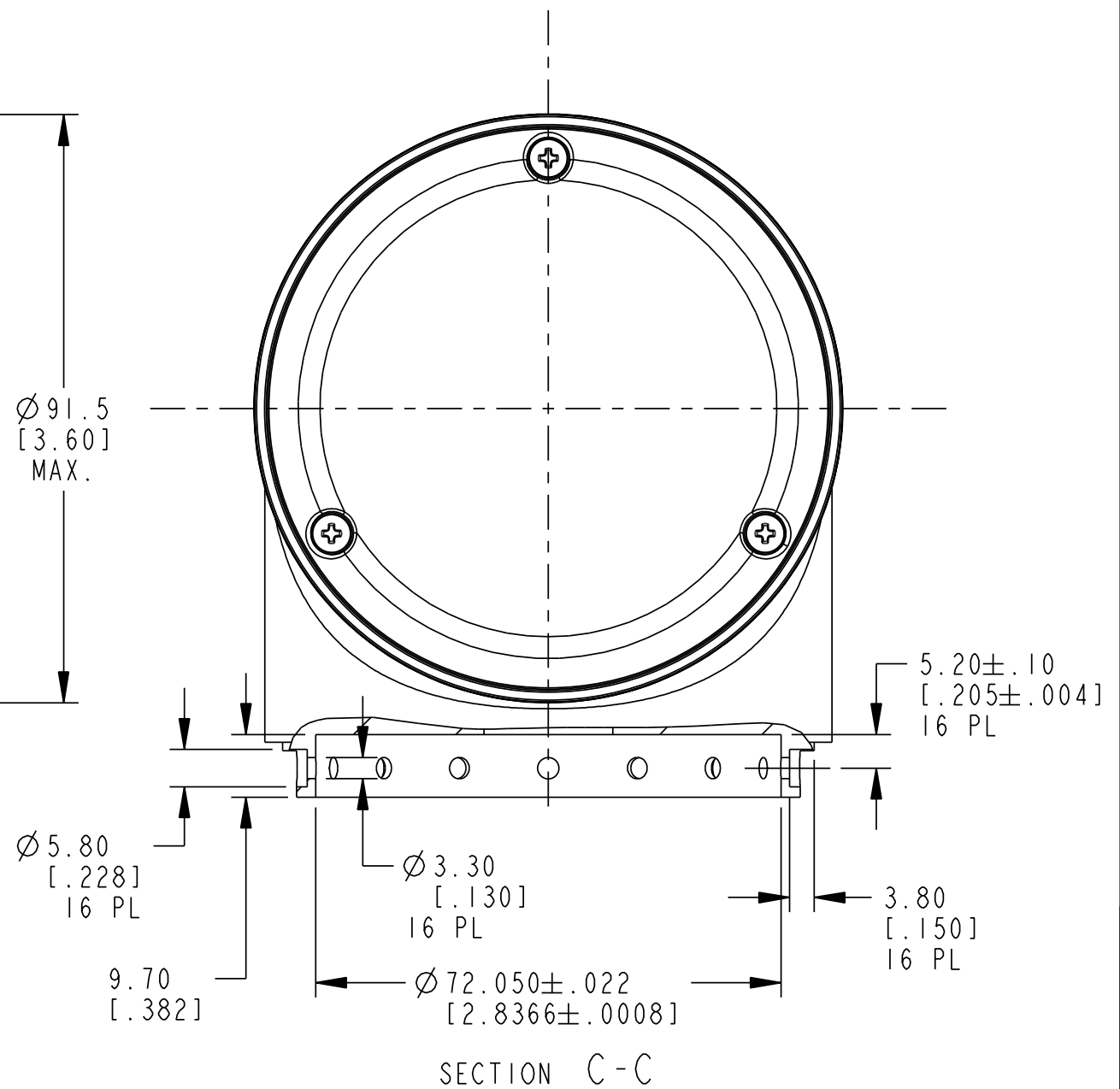
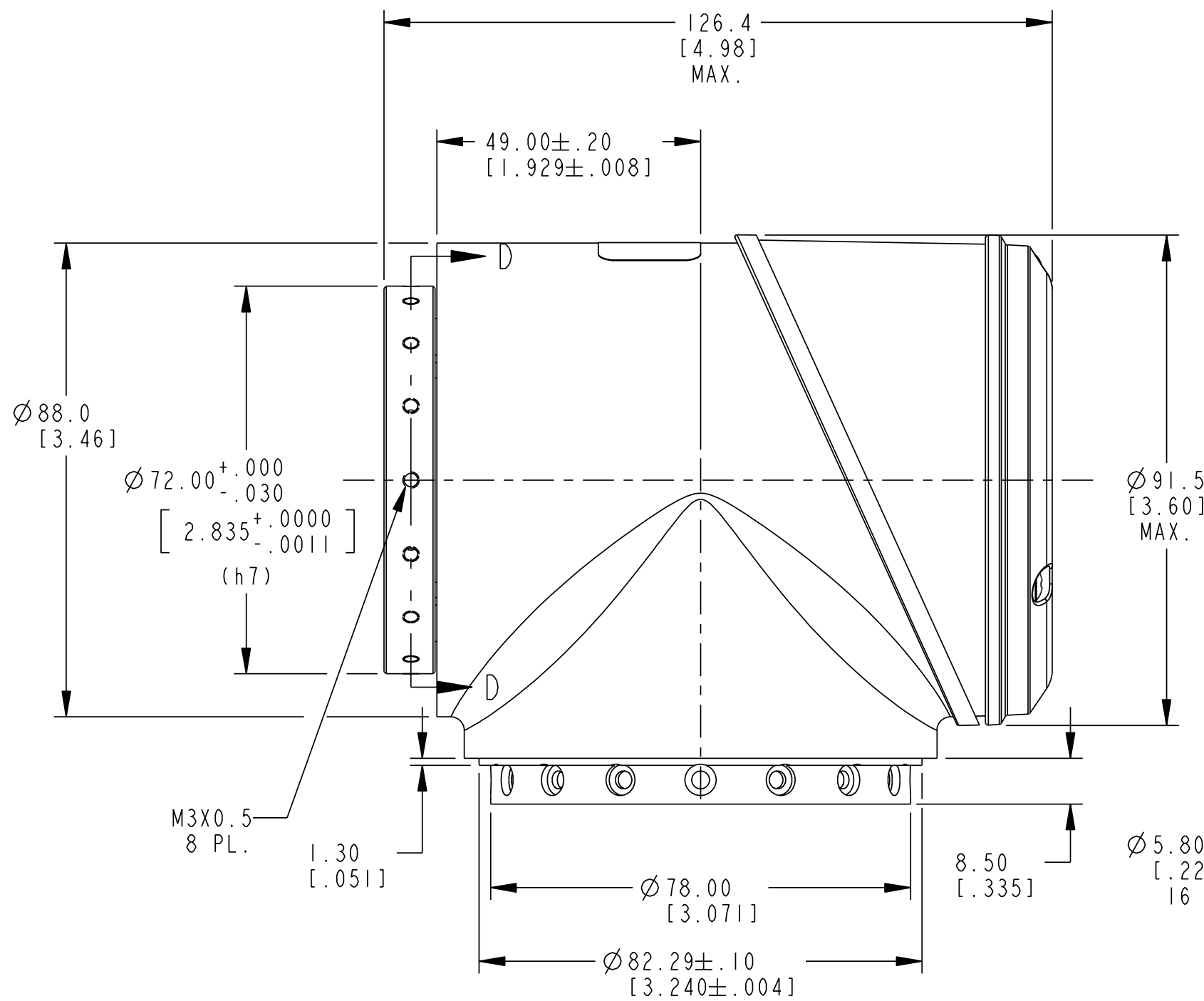
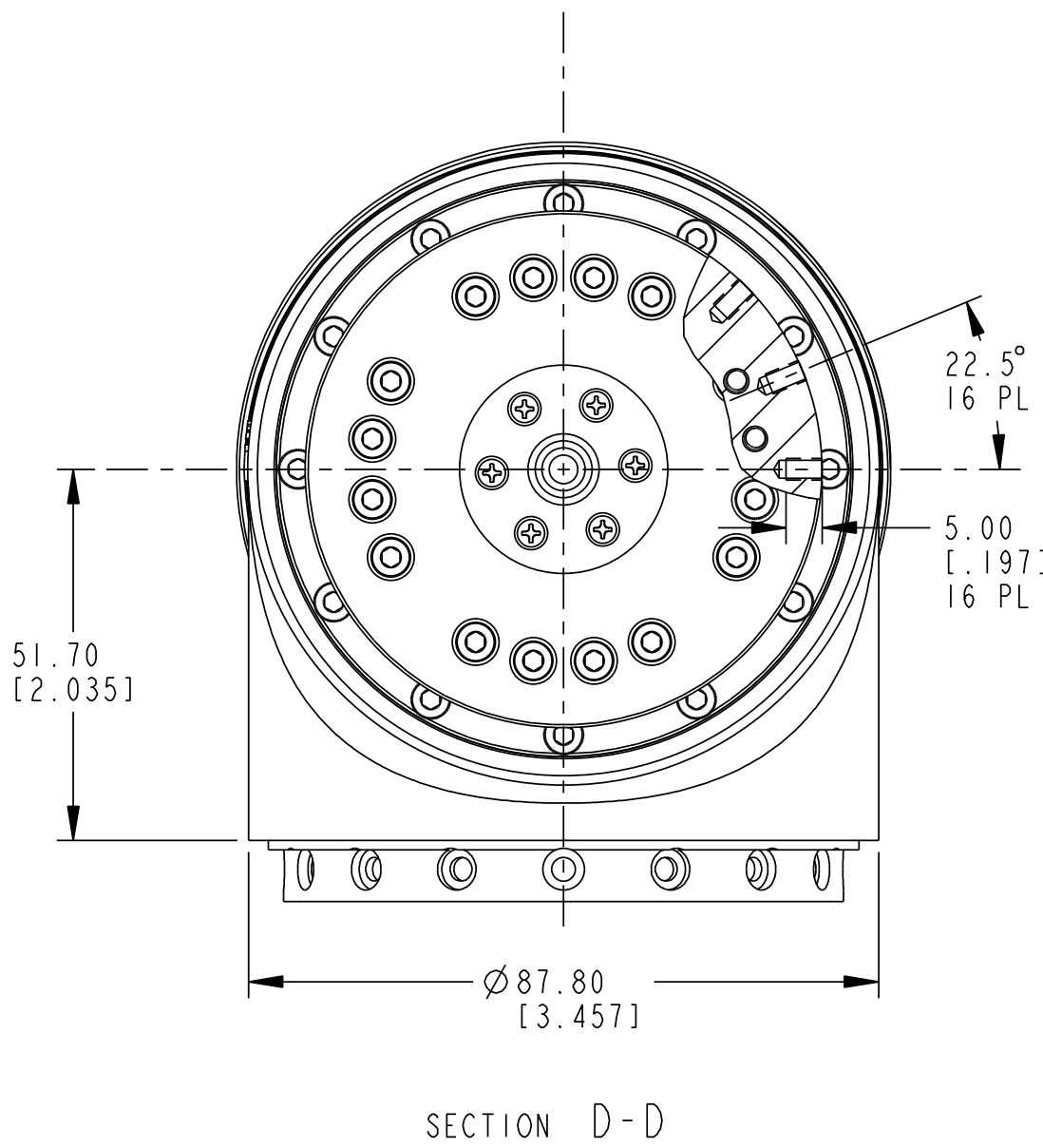

This drawing contains PROPRIETARY information and is the property of KOLLMORGEN. This drawing may not be copied or used without prior written approval of KOLLMORGEN.	
INTERPRET GEOMETRIC SYMBOLS PER ANSI Y14.5M-1994	
Pro/E Model File Rev	proi_revision
Pro/E Instance Name	RGM17_MAIN_CAN
Pro/E Drawing Name	969644
Pro/E Model Type	ASSEM
Pro/Engineer Drawing	

SIGNIFICANT PRODUCT CHARACTERISTIC	UNLESS OTHERWISE SPECIFIED: DIMENSIONS APPLY BEFORE COATINGS REMOVE ALL SHARP BURRS AND BREAK ALL SHARP EDGES		KOLLMORGEN <small>Design Control Location: 201 West Rock Road Radford, Virginia 24141 United States of America</small>			
	MILLIMETER VALUES: ANGULAR TOLERANCE: ±1° XX DEC. PLACE: ±.4mm XXX DEC. PLACE: ±.13mm	[INCH] VALUES: ANGULAR TOLERANCE: ±1° XX DEC. PLACE: ±.015" XXX DEC. PLACE: ±.005"				
CRITICAL PRODUCT CHARACTERISTIC	DO NOT SCALE DRAWING USE DIMENSIONS ONLY ALL DIMENSIONS ARE MM [INCH] INCH DIMENSIONS IN BRACKETS [] ARE FOR REFERENCE ONLY		DRAWN BY: BW CHECKED BY: - APPROVED BY: BW	DATE: May-10-17 DATE: - DATE: Jun-14-18	SIZE: C CAGE CODE: - DWG. NO.: 969644 SCALE: 1:1	REV: B SHEET 1 OF 1

MILLIMETERS

DWG. NO. 969644 REV B