

R4 Rodless Actuator

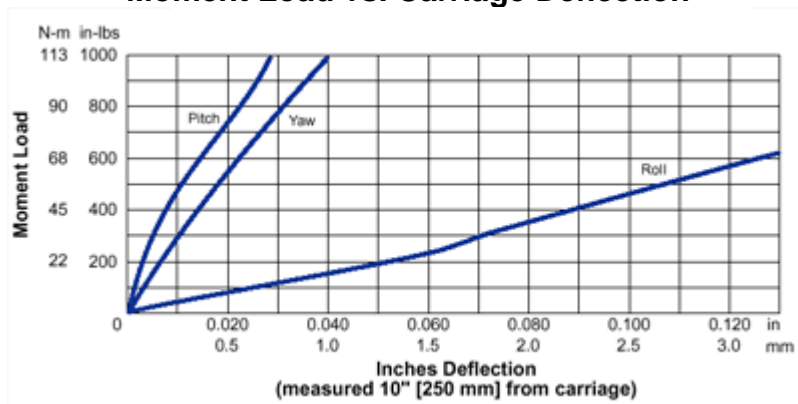

Product Dimensions

Moment Load vs. Carriage Deflection



Moment Load vs. Carriage Deflection Diagram

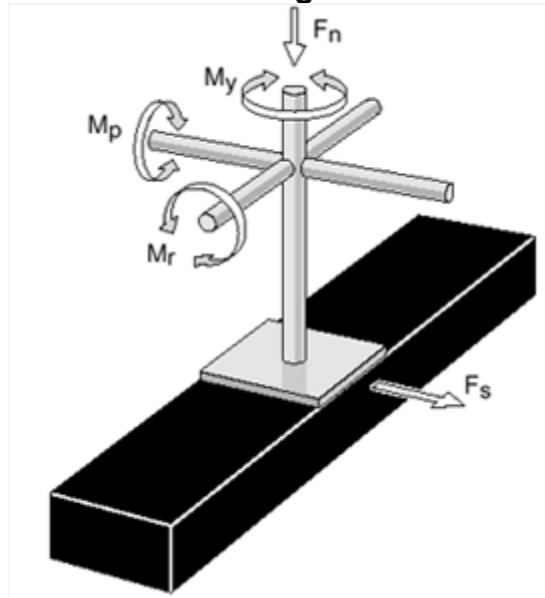

R4 Rodless Actuator

Maximum Overhanging Load

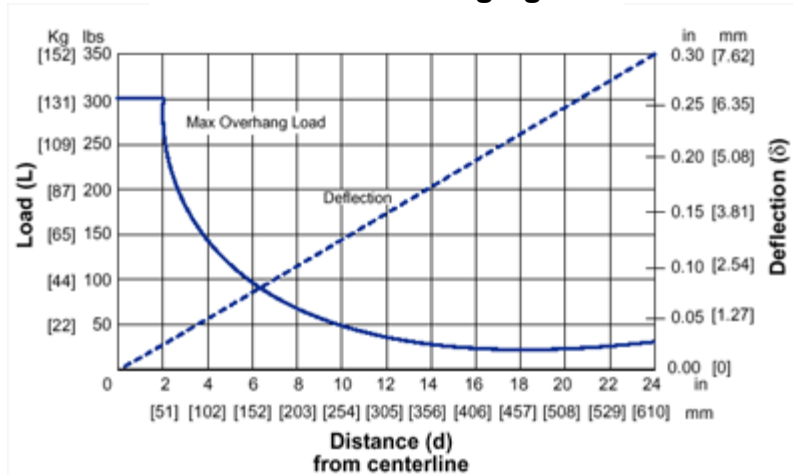

Maximum Overhanging Load Diagram

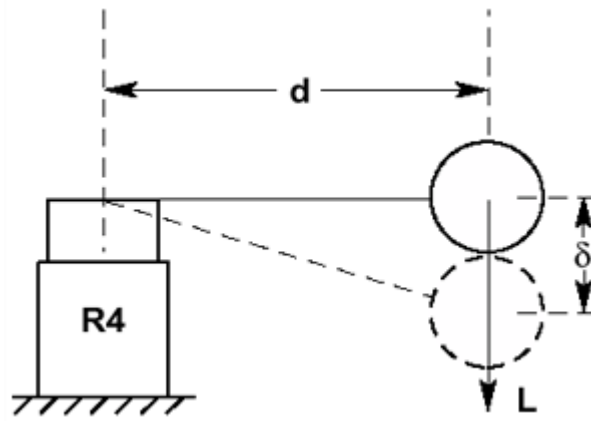

Maximum Side Load

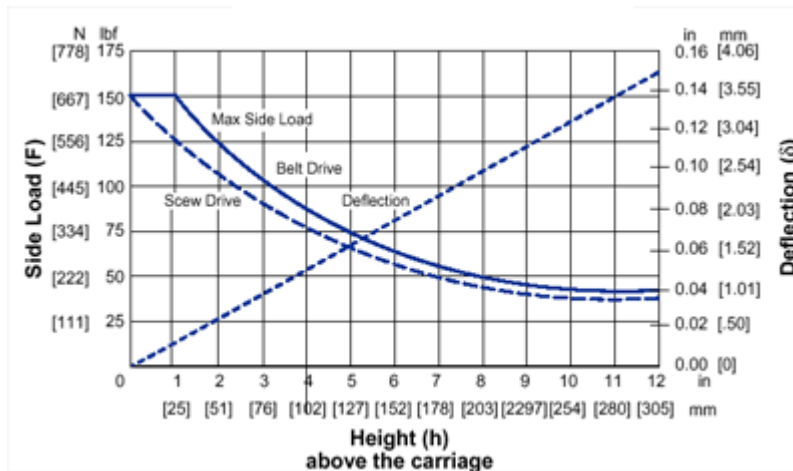

R4 Rodless Actuator

Maximum Side Load Diagram

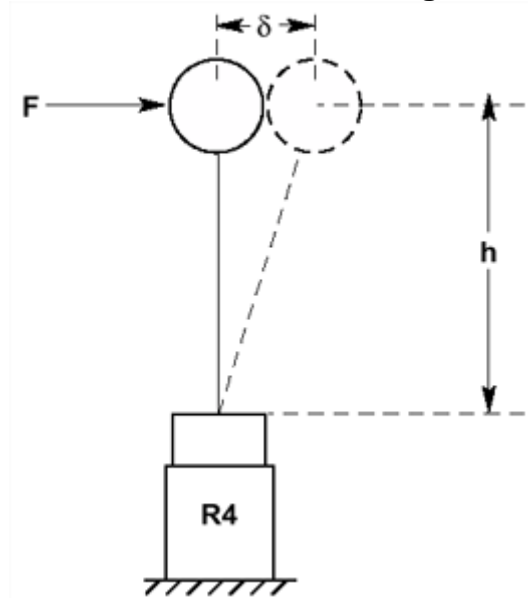

Carriage Load vs. Rail Life

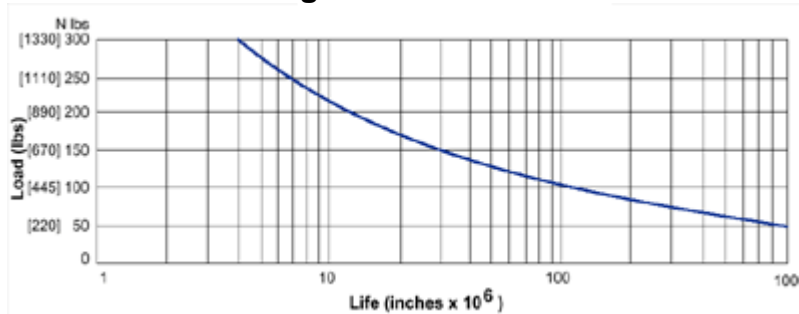

Ball Screw Life vs. Travel Life

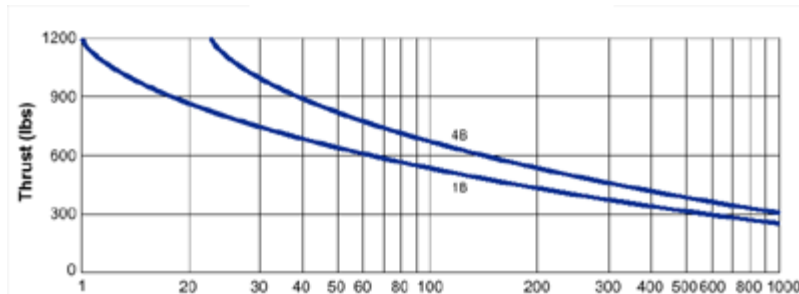

R4 Rodless Actuator

Actuator Deflection

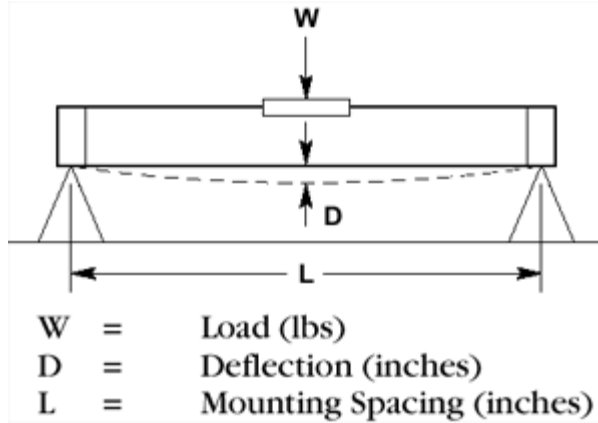

Deflection vs. Normal Load

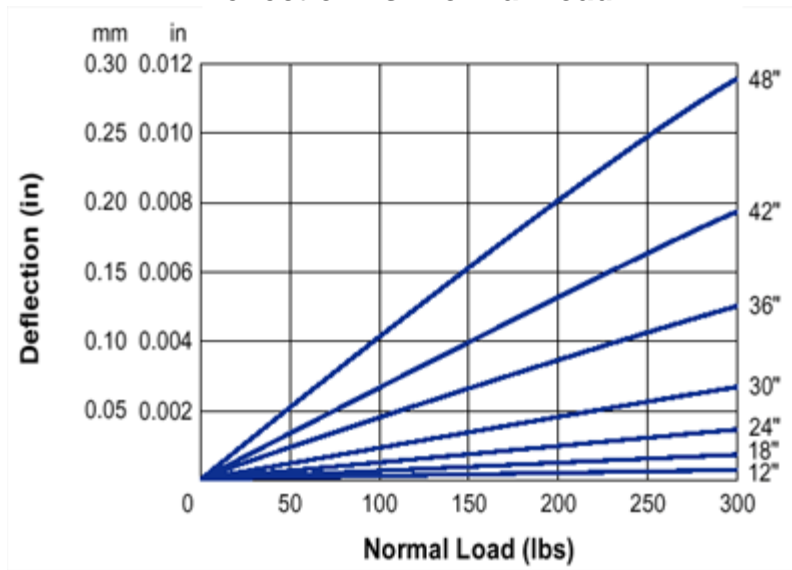

Carriage Dimensions

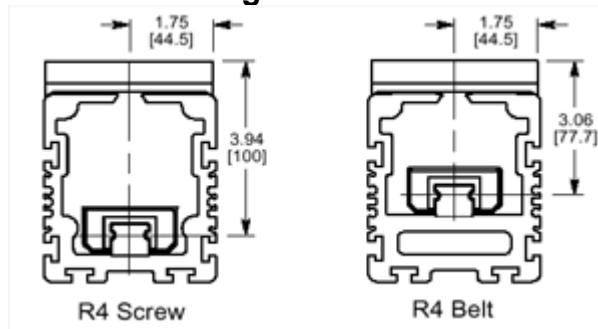



R4 Rodless Actuator

Specifications

	R4-H Series	R4-S Series	R4-B Series
Load (Thrust) Capacity (lbs [N])	1,200 [5,300] screw drive, 300 [1,300] belt drive		
Max. No Load Speed (in/s [m/s])	40 [1,000] screw drive, 120 [3,000] belt drive		
Max. Carriage Load (lbs [kg])	300 [135]		
Repeatability (in [mm])	±0.001 [±0.025]	± 0.0005 [±0.013]	± 0.001 [±0.025]
Peak Power (W)	1,000	600	1,900
Continuous (W)	500	600	1,050
Motor Type	160 volt DC Servo Stepper	1.8° Hybrid	Brushless Servo
Compatible Controls Offered (Model)	B8001 B8961 B8962	NextStep SmartStep S6002 S6961 S6962	B8001 B8961 B8962

*System cost based on single quantity price, 30 inch stroke actuator with control.

Common Specifications

Travel Lengths	6, 12, 18, 24, 30, 36, 42, 48, 60, 72, 84, 96, 108 inches																		
Construction Materials	Bearing & Drive Housing 6063-T6 aluminum, hardcoat anodized																		
	Guide Housing 6063-T6 aluminum, hardcoat anodized																		
	Carriage Assembly 6061-T6 aluminum, hardcoat anodized																		
	Internal Rail Bearings Recirculating ball on precision ground rail																		
Leadscrew or belt	Support Bearings Angular contact, high thrust ball bearings																		
	Ball Screw; drive nut 1.0" diameter hardened alloy steel screw; alloy steel, heat treated ballnut																		
	Belt Drive 1.5" wide L pitch urethane with steel reinforcement cords																		
	Flexible Seal Stainless steel band with elastomeric seal																		
Weight	<table border="0"> <thead> <tr> <th></th> <th>Screw-driven Actuators</th> <th>Belt-driven Actuators</th> </tr> </thead> <tbody> <tr> <td>R4-H4</td> <td>36 + 0.85 ´ (inches stroke) lbs</td> <td>36 + 0.64 ´ (inches stroke) lbs</td> </tr> <tr> <td>R4-S33</td> <td>32 + 0.85 ´ (inches stroke) lbs</td> <td>32 + 0.64 ´ (inches stroke) lbs</td> </tr> <tr> <td>R4-S42 40</td> <td>40 + 0.85 ´ (inches stroke) lbs</td> <td>40 + 0.64 ´ (inches stroke) lbs</td> </tr> <tr> <td>R4-B32</td> <td>30 + 0.85 ´ (inches stroke) lbs</td> <td>30 + 0.64 ´ (inches stroke) lbs</td> </tr> <tr> <td>R4-B41</td> <td>36 + 0.85 ´ (inches stroke) lbs</td> <td>36 + 0.64 ´ (inches stroke) lbs</td> </tr> </tbody> </table>		Screw-driven Actuators	Belt-driven Actuators	R4-H4	36 + 0.85 ´ (inches stroke) lbs	36 + 0.64 ´ (inches stroke) lbs	R4-S33	32 + 0.85 ´ (inches stroke) lbs	32 + 0.64 ´ (inches stroke) lbs	R4-S42 40	40 + 0.85 ´ (inches stroke) lbs	40 + 0.64 ´ (inches stroke) lbs	R4-B32	30 + 0.85 ´ (inches stroke) lbs	30 + 0.64 ´ (inches stroke) lbs	R4-B41	36 + 0.85 ´ (inches stroke) lbs	36 + 0.64 ´ (inches stroke) lbs
	Screw-driven Actuators	Belt-driven Actuators																	
R4-H4	36 + 0.85 ´ (inches stroke) lbs	36 + 0.64 ´ (inches stroke) lbs																	
R4-S33	32 + 0.85 ´ (inches stroke) lbs	32 + 0.64 ´ (inches stroke) lbs																	
R4-S42 40	40 + 0.85 ´ (inches stroke) lbs	40 + 0.64 ´ (inches stroke) lbs																	
R4-B32	30 + 0.85 ´ (inches stroke) lbs	30 + 0.64 ´ (inches stroke) lbs																	
R4-B41	36 + 0.85 ´ (inches stroke) lbs	36 + 0.64 ´ (inches stroke) lbs																	
Environmental Operation	Temperature -20° to 140°F [-28° to 60°C]																		
	Moisture/Contaminants IP 44 rated: Splash-proof, protected against ingress of solid particles greater than 0.040" [1 mm] diameter.																		

R4 Series Actuator Inertia

Rotary Inertia (reflected to the motor) = A + B* (stroke, in) + C* (load, lb) + D

Linear Inertia (reflected to the carriage) = [A + B* (stroke, in) + D]/C + (load, lb)

Belt Driven

Model	Motors	Ratio	Screw	A (lb-in-s ²)	B (lb-in-s ² /in)	C (lb-in-s ² /lb)
R4...-20T	H4, S42, B42	2:1	1.5 wide	6.06 E-03	1.06 E-05	9.02 E-04
R4...-30T	S33, B32	3:1		2.32 E-03	4.71 E-06	4.01 E-04
R4...-50T	All	5:1		1.07 E-03	1.62 E-06	1.38 E-04
R4...-100T	All	10:1		4.40 E-04	4.21 E-07	3.60 E-05

R4 Rodless Actuator

Screw Driven

Model	Motors	Ratio	Screw	A (lb-in-s ²)	B (lb-in-s ² /in)	C (lb-in-s ² /lb)
R4...-101B	All	1:1	1x1	2.17 E-03	7.12 E-05	6.56 E-05
R4...-151B	All	1.5:1		1.04 E-03	3.17 E-05	2.92 E-05
R4...-201B	All	2:1		6.63 E-04	1.78 E-05	1.64 E-05
R4...-501B	All	5:1		4.32 E-04	2.72 E-06	2.51 E-06
R4...-1001B	All	10:1		2.75 E-04	7.12 E-07	6.48 E-07
R4...-104B	All	1:1	1x0.25	1.80 E-03	7.12 E-05	4.10 E-06
R4...-154B	All	1.5:1		8.99 E-04	3.17 E-05	1.83 E-06
R4...-204B	All	2:1		5.84 E-04	1.78 E-05	1.02 E-06
R4...-504B	All	5:1		4.20 E-04	2.72 E-06	1.62 E-07
R4...-1004B	All	10:1		2.72 E-04	7.12 E-07	4.86 E-08

Motor	Inertia (lb-in-s ²)
H4	1.25 E-02
S33	1.66 E-03
S42	7.13 E-03
B32	1.00 E-03
B41	2.60 E-03

Metric Conversions:

1 mm = 0.03937 in

1 kg = 2.205 lb

1 lb-in-s² = 1129 kg-cm² = 1.152 kg-cm-s²

Carriage

Straightness & Flatness	±0.005 in/ft [0.125 mm/300 mm], not to exceed ±0.035 in [0.9 mm]
Load Limits	
Normal (F _n)	±300 lbs [±1330 N]
Side (F _s)	±150 lbs [667 N]
Pitch (M _p)	1,000 in-lbs* [113 N-m]
Roll (M _r)	600 in-lbs* [68 N-m]
Yaw (M _y)	1,000 in-lbs [113 N-m]

* Be sure to add distance from carriage to bearing centerline to moment arm for pitch and roll calculations.

Deflection

Orientation	Deflection Equation	Maximum Allowed
Normal	WL 3 / 2.8 ´ 10 ⁹ , inches	0.010" [0.25 mm]
Side	WL 3 / 1.3 ´ 10 ⁹ , inches	0.010" [0.25 mm]
Pitch	3 ´ 10 ⁻⁶ radians/in-lb	0.003 radians @ 1,000 in-lbs
Roll	2 ´ 10 ⁻⁵ radians/in-lb	0.013 radians @ 600 in-lbs
Yaw	4 ´ 10 ⁻⁶ radians/in-lb	0.004 radians @ 1,000 in-lbs