

MMC[®] Smart Drive[™] and Digital MMC Control Hardware Manual



Version 4.1
Catalog No. M.1301.5524
Part No. M.3000.0827



**IND. CONT. EQ.
12KP**

Keep all product manuals as a product component during the life span of the product.
Pass all product manuals to future users/owners of the product.

KOLLMORGEN[®]

Because Motion Matters[™]

Record of Revisions

Edition	Valid for	Description
03/2007	PiCPro V16.1	Major Update
10/2007	PiCPro V16.1 SP2	Added MMC-D8
05/2008	PiCPro V16.1 SP3	Added 4 analog drives, various manual updates
09/2008	PiCPro V17.0	Added S200-DLS Drives
12/2008	PiCPro V17.0	Rev 1 fixed various typos
01/2009	PiCPro V17.0	Rev 2 added CE/UL info to S200-DLS
03/2009	PiCPro V17.0	Rev 3 added Aux Feedback Connector to S200DLS
02/2010	PiCPro V18.0	Kollmorgen Branding & S200 BiSS

Third party brands and trademarks are the property of their respective owners

Technical changes to improve the performance of the equipment may be made without notice!

Printed in USA

All rights reserved. No part of this work may be reproduced in any form (by printing, photocopying, microfilm or any other method) or processed, copied or distributed by electronic means without the written permission of Kollmorgen.

NOTE

These products are being manufactured and sold by G & L Motion Control, Inc., a Kollmorgen company.

Progress is an on-going commitment at Kollmorgen. We continually strive to offer the most advanced products in the industry; therefore, information in this document is subject to change without notice. The text and illustrations are not binding in detail. Kollmorgen shall not be liable for any technical or editorial omissions occurring in this document, nor for any consequential or incidental damages resulting from the use of this document.

Kollmorgen makes every attempt to ensure accuracy and reliability of the specifications in this publication. Specifications are subject to change without notice. Kollmorgen provides this information "AS IS" and disclaims all warranties, express or implied, including, but not limited to, implied warranties of merchantability and fitness for a particular purpose. It is the responsibility of the product user to determine the suitability of this product for a specific application.

DO NOT ATTEMPT to use any Kollmorgen product until the use of such product is completely understood. It is the responsibility of the user to make certain proper operation practices are understood. Kollmorgen products should be used only by qualified personnel and for the express purpose for which said products were designed.

Should information not covered in this document be required, contact the Customer Service Department, Kollmorgen, 672 South Military Road, P.O. Box 1960, Fond du Lac, WI 54936-1960. Kollmorgen can be reached by telephone at (920) 921-7100 or (800) 558-4808 in the United States or by e-mail at glmotion.support@kollmorgen.com.

Catalog No. (Order No.) M.1301.5524

Printed Version Part No. M.3000.0827

Electronic Version Part No. M.3000.0826

Release 04262010

©2010, Kollmorgen

Table of Contents

Table of Contents	3
1 Introduction to the MMC Smart Drive	9
1.1 Overview.....	9
1.2 Contents of This Manual.....	9
1.3 Software and Manuals.....	10
1.3.1 Required Software and Manuals.....	10
1.3.2 Suggested Manuals.....	10
1.4 Kollmorgen Support Contact.....	10
2 Safety Precautions	11
2.1 System Safety.....	11
2.1.1 User Responsibility.....	11
2.1.2 Safety Instructions.....	11
2.2 Safety Signs.....	12
2.3 Warning Labels.....	12
2.4 Safety First.....	13
2.5 Safety Inspection.....	13
2.5.1 Before Starting System.....	13
2.6 After Shutdown.....	13
2.7 Operating Safely.....	14
2.8 Electrical Service & Maintenance Safety.....	14
2.9 Safe Cleaning Practices.....	15
3 Installing the MMC Smart Drive	17
3.1 Storing the Drive Before Installation.....	17
3.2 Unpacking the Drive.....	17
3.3 Handling an MMC Smart Drive.....	17
3.4 Inspecting the Drive Before Installation.....	17
3.5 Complying with European Directives.....	18
3.6 Conforming with UL and cUL Standards.....	18
3.7 General Installation and Ventilation Requirements.....	18
3.8 Controlling Heat Within the System.....	19
3.9 Bonding.....	20
3.9.1 Bonding a Subpanel Using a Stud.....	20
3.9.2 Bonding a Ground Bus Using a Stud.....	20
3.9.3 Bonding a Ground Bus or Chassis Using a Bolt.....	20
3.9.4 Grounding Multiple Drive Cabinets.....	21
3.9.5 Bonding Multiple Subpanels.....	21
3.10 Drive Mounting Guidelines.....	21
3.11 Drive System Grounding Procedures.....	22
3.11.2 Grounding Multiple Drives in the Same Cabinet.....	25
3.12 System Wiring Guidelines.....	25
3.12.1 Recommended Signal Separation.....	26
3.12.2 Building Your Own Cables.....	28
3.12.3 Routing Cables.....	28
3.13 Wiring the Drive.....	28
3.13.1 Sizing the 24V Power Supply.....	28
3.13.2 System AC Power Wiring Guidelines.....	29
3.13.3 Connecting Interface Cables.....	30
3.13.4 Preparing Motor Connection Wires.....	31

4 System Power Protection and Related Devices	35
4.1 AC Input Power Requirements.....	35
4.2 Protection	36
4.2.1 Motor Overload Protection.....	36
4.2.2 Motor Thermal Protection	36
4.2.3 230V Smart Drive Protection Requirements.....	36
4.2.4 460V Smart Drive Protection Requirements.....	37
4.3 Line Reactors.....	40
4.3.1 Specifications and Dimensions for Required Line Reactors.....	41
4.4 Isolation Transformers	47
4.5 External Shunts.....	48
4.5.1 Choosing an External Shunt.....	48
4.5.2 External Shunt Resistor Kits.....	49
4.6 Line Filters.....	53
4.6.1 Line Filters and CE Compliance	53
4.6.2 Dimensions for 230V Line Filters.....	58
4.6.3 Dimensions for 460V Line Filters.....	59
5 230V Single Phase MMC Smart Drive	61
5.1 Control Section Connectors, Switches, LEDs	63
5.1.1 LEDs.....	63
5.1.2 PiCPro Port (Digital Interfaced Drives).....	63
5.1.3 PiCPro Port (Analog Drives).....	65
5.1.4 Node Address Rotary Switch (Digital Interfaced MMC-SD Only)	68
5.1.5 Digital Link Ports (Digital Interfaced MMC-SD Only)	69
5.1.6 Feedback Connectors (F1 & F2)	71
5.1.6.1 Feedback Connectors (F1 and F2) Details	76
5.1.6.2 Feedback Port (F1/F2) to Motor Cables.....	80
5.1.7 Drive I/O Connector (IO).....	89
5.2 Power Section Connectors.....	96
5.2.1 24 VDC IN/Brake Connector	96
5.2.2 Motor Connector.....	98
5.3 Specifications - 230V MMC Smart Drive.....	99
5.3.1 General Data for all 230V Models	99
5.3.2 Physical and Electrical Data for 230V Drives	102
5.4 Dimensions for 230V MMC Smart Drive	103
6 460V 3-Phase MMC Smart Drive.....	109
6.1 Control Section Connectors, Switches, LEDs	109
6.2 Power Section Connectors.....	109
6.2.1 Size 1 Power Section Connectors	109
6.2.1.1 Shunt/DC Bus Connector	111
6.2.1.2 AC Power Connector	112
6.2.1.3 Motor Connector	112
6.2.1.4 24V Power Connector (J1).....	113
6.2.1.5 Motor Brake Connector (X101)	114
6.2.2 Size 2 Power Section Connectors	114
6.2.2.1 AC Power Connector	116
6.2.2.2 Motor Connector	117
6.2.2.3 24V Power Connector (J1).....	118
6.2.3 Size 3 Power Section Connectors	119
6.2.3.1 AC Power Connector	121
6.2.3.2 Motor Connector	122
6.2.3.3 24V Power Connector (J1).....	123

6.2.3.4 Motor Brake Connector (X101).....	124
6.2.4 Size 4 Power Section Connectors.....	124
6.2.4.1 AC Power Connector	126
6.2.4.2 Motor Connector.....	127
6.2.4.3 24V Power Connector (J1)	128
6.2.4.4 Motor Brake Connector (X101).....	129
6.2.4.5 Fan Connector (X36)	130
6.3 Typical 460V Drive Connection Layout	131
6.4 Specifications - 460V MMC Smart Drive)	132
6.4.1 Common Data for Size 1, 2, 3, 4 (All Models).....	132
6.4.2 Physical/Electrical Data for 460V Size 1 Smart Drives	135
6.4.3 Physical/Electrical Data for 460V Size 2 Smart Drives	137
6.4.4 Physical/Electrical Data for 460V Size 3 Smart Drives	139
6.4.5 Physical/Electrical Data for 460V Size 4 Smart Drives	141
6.5 Dimensions for the 460V Smart Drives	143
7 S200-DLS Drive	151
7.1 S200-DLS Option Card.....	153
7.1.1 LED Indicators.....	153
7.1.2 Diagnostic Indicator Details.....	153
7.1.3 Digital Link LEDs.....	153
7.1.4 Node Address Rotary Switches	153
7.1.5 Digital Link Ports	155
7.1.6 Auxiliary Feedback Port	157
7.1.7 Drive I/O and I/O Power Ports.....	164
7.1.8 Drive I/O Port Details	167
7.1.8.1 Drive I/O Port Outputs	167
7.1.8.2 Drive I/O Port Inputs	167
7.1.8.3 Drive I/O Port Wiring Example.....	167
7.2 Specifications - S200-DLS Drive	169
8 Cables and Connections to External Devices	171
8.1 Flex Cable Installation Guidelines	171
8.1.1 Bending Radius.....	171
8.1.2 Cable Tension	172
8.2 Flex Cable Installation	172
8.3 Motor Power/Fan/Brake Cable Pin Assignments	174
8.4 Connecting Shunt Modules	179
8.4.1 Connecting the 230V MMC Smart Drive to 300 W Shunt Module	179
9 Maintenance and Troubleshooting.....	183
9.1 Maintenance	183
9.2 Troubleshooting.....	184
9.2.1 General Troubleshooting.....	184
9.2.2 Power-On Diagnostics	184
9.2.2.1 Power LED	184
9.2.2.2 Diagnostic LEDs	184
9.2.3 Run-Time Diagnostics.....	185
9.2.3.1 Troubleshooting with the Diagnostic LED (D1).....	185
9.2.3.2 Troubleshooting using the Status LED (STATUS).....	192
10 Resolver Interface Option Module.....	197
10.1 Theory of Operation.....	197
10.2 Installing the Resolver Module	197

11 Drive Resident Digital MMC Control	201
11.1 Introduction	201
11.1.1 Overview.....	201
11.1.2 Major Components	201
11.2 Installing the Drive Resident Digital MMC Control	203
11.2.1 Installing into a 230V MMC-SD Drive	203
11.2.2 Installing into a 460V MMC-SD Drive	203
11.3 System Wiring Guidelines	204
11.4 Starting an Operation	205
11.4.1 Connecting the Drive Resident Digital MMC Control to the Application	205
11.4.2 Basic Setup and Maintenance Procedures	205
11.4.3 Start-up Diagnostics	206
11.4.3.1 Power LED	206
11.4.3.2 Scan LED	206
11.4.3.3 Drive Resident Digital MMC Control Start-Up Diagnostic LEDs	207
11.4.4 MMC Run-Time Diagnostics.....	208
11.5 Connectors & Operation.....	209
11.5.1 PiCPro Port (P1).....	209
11.5.2 Block I/O Port (C1)	209
11.5.3 User Port	213
11.5.4 Ethernet Port	219
11.5.5 General I/O Port (C5)	221
11.5.5.1 DC Output Operation	226
11.5.5.2 DC Input Operation	228
11.6 Specifications	230
12 Part Numbers	233
12.1 230V Smart Drives	233
12.2 460V Smart Drives	234
12.3 S200-DLS Drives and Accessories	236
12.4 Combination Fuses	237
12.5 Option Modules.....	238
12.5.1 Resolver Interface Option Module	238
12.5.2 Drive Resident Digital MMC Control.....	238
12.6 Direct Connect Cables	239
12.6.1 Drive Programming Cable	239
12.6.2 Standalone MMC to MMC Smart Drive I/O Cable	239
12.7 Digital Link and Networking Cables	239
12.8 Connector Kits	240
12.9 Breakout Boards and Cables	241
12.9.1 Drive Mounted Breakout Boards	241
12.9.2 Panel Mounted Breakout Boards.....	241
12.9.3 Breakout Board Kits.....	241
12.9.4 Breakout Board Cables	242
12.9.5 Flying Lead Cables.....	243
12.10 Motor Cables (AKM/DDR Motors)	244
12.10.1 Feedback Cables (AKM/DDR Motors).....	245
12.10.2 Motor Power Cables (AKM/DDR Motors)	247
12.11 Motor Cables (LSM/MSM Motors).....	248
12.11.1 Feedback Cables (LSM/MSM Motors)	248
12.11.2 Power Cables for Blower Fan (LSM/MSM Motors).....	249
12.11.3 Motor Power Cables (LSM/MSM Motors).....	249
12.12 Optional External Devices	251
12.12.1 AC Line Filters	251

12.12.2 AC Line Reactors	251
12.12.3 External Shunt Resistor Kits	252
12.13 Software	252
13 Declarations of Conformity	253
Appendix A - 460V MMC Smart Drive DC Bus Sharing	259
A.1 Introduction	259
A.2 DC Bus Sharing with AC Power to All Drives.....	259
A.3 DC Bus Sharing with AC Power to One Drive.....	261
Index.....	265
Sales and Service.....	270

1 Introduction to the MMC Smart Drive

1.1 Overview

This manual covers three distinct products:

- The Analog Interfaced MMC Smart Drive (MMC-SD) which receives motion commands via a $\pm 10V$ analog input
- The Digital MMC Smart Drive (MMC-SD) which receives motion commands via a digital connection (Digital Link)
- The S200-DLS Digital Link Drive which receives motion commands via a digital connection (Digital Link)

Unless otherwise noted, all of the information in this manual applies to both the Analog Interfaced MMC Smart Drive and the Digital MMC Smart Drive, but not to the S200-DLS Drive. The S200-DLS Drive is detailed exclusively in [Chapter 7 on page 151](#).

Features include:

- 230V, Single Phase drives available with power ratings of .5kW, 1kW, and 2 kW
- 460V, Three Phase drives available with power ratings of 1.3kW through 65kW
- Drive firmware in user upgradeable Flash memory
- Serial port for communications with PC-resident PiCPro
- Internal switch to control a mechanical brake
- Green Power LED and yellow Diagnostic LED
- Motor feedback types include incremental encoder, high resolution encoder, and resolver
- Eight General Purpose 24VDC Inputs
- Four General Purpose 24VDC outputs
- $\pm 10V$ command input (Analog Interfaced MMC-SD only)
- Digital Link digital connections (Digital MMC-SD only)
- Optional MMC-SD Control (for Digital MMC-SD only)
- UL Listed and CE Marked.

1.2 Contents of This Manual

This manual includes the following major topics:

- Information to safely operate and maintain the equipment in a safe manner.
- User responsibilities for product acceptance and storage.
- Power and environmental information for general power, control cabinet, grounding, heat control and handling.
- Procedures for mounting, wiring, and connecting the MMC Smart Drive and standard Kollmorgen motors recommended for use with the MMC Smart Drive.
- Recommended drive system wiring guidelines for signal separation and differential devices. Methods to ensure ElectroMagnetic Compatibility.

- The location of connectors on the drive and descriptions of their functionality including I/O, encoder, serial interface and motor/brake connector locations and signal descriptions.
- Physical, electrical, environmental and functional specifications/dimensions.
- Description of the minimal maintenance necessary.
- A troubleshooting chart of potential problems and possible solutions.
- Part numbers and descriptions for the drive and related equipment.

1.3 Software and Manuals

1.3.1 Required Software and Manuals

PiCPro (one of the following)

- Professional Edition
- MMC Limited Edition
- Monitor Edition

1.3.2 Suggested Manuals

- Function/Function Block Reference Guide
- Motion Application Specific Function Block Manual
- Ethernet Application Specific Function Block Manual
- General Purpose Application Specific Function Block Manual

1.4 Kollmorgen Support Contact

Contact your local Kollmorgen representative for:

- Sales and order support
- Product technical training
- Warranty support
- Support service agreements

Kollmorgen Technical Support can be reached:

- In the United States, telephone (800) 558-4808
- Outside the United States, telephone (920) 921-7100
- E-mail address: glmotion.support@kollmorgen.com
- Web site: www.glcontrols.com

2 Safety Precautions

READ AND UNDERSTAND THIS SECTION IN ITS ENTIRETY BEFORE UNDERTAKING INSTALLATION OR ADJUSTMENT OF THE MMC SMART DRIVE AND ANY ASSOCIATED SYSTEMS OR EQUIPMENT

The instructions contained in this section will help users to operate and maintain the equipment in a safe manner.

PLEASE REMEMBER THAT SAFETY IS EVERYONE'S RESPONSIBILITY

2.1 System Safety


The basic rules of safety set forth in this section are intended as a guide for the safe operation of equipment. This general safety information, along with explicit service, maintenance and operational materials, make up the complete instruction set. All personnel who operate, service or are involved with this equipment in any way should become totally familiar with this information prior to operating.

2.1.1 User Responsibility

It is the responsibility of the user to ensure that the procedures set forth here are followed and, should any major deviation or change in use from the original specifications be required, appropriate procedures should be established for the continued safe operation of the system. It is strongly recommended that you contact your OEM to ensure that the system can be safely converted for its new use and continue to operate in a safe manner.

2.1.2 Safety Instructions

- Do not operate your equipment with safety devices bypassed or covers removed.
- Only qualified personnel should operate the equipment.
- Never perform service or maintenance while automatic control sequences are in operation.
- To avoid shock or serious injury, only qualified personnel should perform maintenance on the system.

ATTENTION	
	Do not touch the main power supply fuses or any components internal to the power modules while the main power supply switch is ON. Note that when the main power switch is OFF, the incoming supply cable may be live.

- **GROUNDING (Protective Earth)**

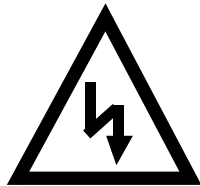
The equipment must be grounded (connected to the protective earth connection) according to OEM recommendations and to the latest local regulations for electrical safety. The grounding (protective earth) conductor must not be interrupted inside or outside the equipment enclosures. The wire used for equipment grounding (connection to protective earth) should be green with a yellow stripe.

2.2 Safety Signs

The purpose of a system of safety signs is to draw attention to objects and situations which could affect personal or plant safety. It should be noted that the use of safety signs does not replace the need for appropriate accident prevention measures. Always read and follow the instructions based upon the level of hazard or potential danger.

2.3 Warning Labels

Hazard warning



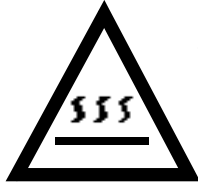
Danger Electric
Shock Risk

When you see this safety sign on a system, it gives a warning of a hazard or possibility of a hazard existing. The type of warning is given by the pictorial representation on the sign plus text if used.

To ignore such a caution could lead to severe injury or death arising from an unsafe practice.

Danger, Warning, or Caution warning

Symbol plus DANGER, WARNING or CAUTION:
These notices provide information intended to prevent potential personal injury and equipment damage.

Hot Surface warning

Symbol plus HOT SURFACE:
These notices provide information intended to prevent potential personal injury.

2.4 Safety First

Kollmorgen equipment is designed and manufactured with consideration and care to generally accepted safety standards. However, the proper and safe performance of the equipment depends upon the use of sound and prudent operating, maintenance and servicing procedures by trained personnel under adequate supervision.

For your protection, and the protection of others, learn and always follow these safety rules. Observe warnings on machines and act accordingly. Form safe working habits by reading the rules and abiding by them. Keep these safety rules handy and review them from time to time to refresh your understanding of them.

2.5 Safety Inspection**2.5.1 Before Starting System**

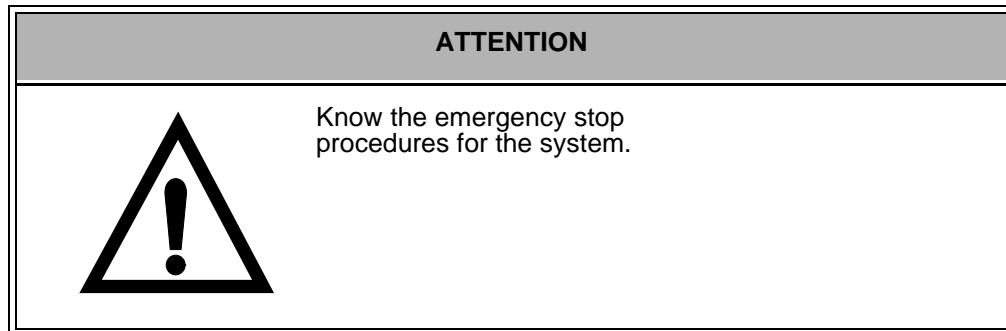
- Ensure that all guards and safety devices are installed and operative and all doors which carry warning labels are closed and locked.
- Ensure that all personnel are clear of those areas indicated as potentially hazardous.
- Remove (from the operating zone) any materials, tools or other objects that could cause injury to personnel or damage the system.
- Make sure that the control system is in an operational condition.
- Make certain that all indicating lights, horns, pressure gauges or other safety devices or indicators are in working order.

2.6 After Shutdown

Make certain all controlled equipment in the plant is safe and the associated electrical, pneumatic or hydraulic power is turned off. It is permissible for the control equipment contained in enclosures to remain energized provided this does not conflict with the safety instructions found in this section.

2.7 Operating Safely

- Do not operate the control system until you read and understand the operating instructions and become thoroughly familiar with the system and the controls.
- Never operate the control system while a safety device or guard is removed or disconnected
- Where access to the control system is permitted for manual operation, only those doors which provide that access should be unlocked. They should be locked immediately after the particular operation is completed.
- Never remove warnings that are displayed on the equipment. Torn or worn labels should be replaced.
- Do not start the control system until all personnel in the area have been warned.
- Never sit or stand on anything that might cause you to fall onto the control equipment or its peripheral equipment.
- Horseplay around the control system and its associated equipment is dangerous and should be prohibited.




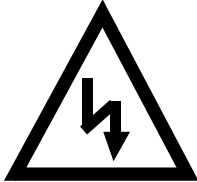
- Never operate the equipment outside specification limits.
- Keep alert and observe indicator lights, system messages and warnings that are displayed on the system.
- Do not operate faulty or damaged equipment. Make certain proper service and maintenance procedures have been performed.

2.8 Electrical Service & Maintenance Safety

- **ALL ELECTRICAL OR ELECTRONIC MAINTENANCE AND SERVICE SHOULD BE PERFORMED BY TRAINED AND AUTHORIZED PERSONNEL ONLY.**
- It should be assumed at all times that the POWER is ON and all conditions treated as live. This practice assures a cautious approach which may prevent accident or injury.
- To remove power:
LOCK THE SUPPLY CIRCUIT DISCONNECTING MEANS IN THE OPEN POSITION.
APPLY LOCKOUT/TAGOUT DEVICES IN ACCORDANCE WITH A DOCUMENTED AND ESTABLISHED POLICY.

- Make sure the circuit is safe by using the proper test equipment. Check test equipment regularly.

ATTENTION	
	Care should be taken if you are manually discharging the bus capacitors.

WARNING	
	Even after power to the drive is removed, it may take up to 10 minutes for bus capacitors to discharge to a level below 50 VDC. To be sure the capacitors are discharged, measure the voltage across the + and - terminals for the DC bus.

- There may be circumstances where troubleshooting on live equipment is required. Under such conditions, special precautions must be taken:
 - Make sure your tools and body are clear of the areas of equipment which may be live.
 - Extra safety measures should be taken in damp areas.
 - Be alert and avoid any outside distractions.
 - Make certain another qualified person is in attendance.
- Before applying power to any equipment, make certain that all personnel are clear of associated equipment.
- Control panel doors should be unlocked only when checking out electrical equipment or wiring. On completion, close and lock panel doors.
- All covers on junction panels should be fastened closed before leaving any job.
- Never operate any controls while others are performing maintenance on the system.
- Do not bypass a safety device.
- Always use the proper tool for the job.
- Replace the main supply fuses only when electrical power is OFF (locked out).

2.9 Safe Cleaning Practices

- Do not use toxic or flammable solvents to clean control system hardware.
- Turn off electrical power (lock out) before cleaning control system assemblies.
- Keep electrical panel covers closed and power off when cleaning an enclosure.

- Always clean up spills around the equipment immediately after they occur.
- Never attempt to clean a control system while it is operating.
- Never use water to clean control equipment unless you are certain that the equipment has been certified as sealed against water ingress. Water is a very good conductor of electricity and the single largest cause of death by electrocution.

3 Installing the MMC Smart Drive

NOTE

The National Electrical Code and any other governing regional or local codes overrule the information in this manual. Kollmorgen does not assume responsibility for the user's compliance or non-compliance with any code, national, local or otherwise, for the proper installation of this drive and associated systems or equipment. Failure to abide by applicable codes creates the hazard of personal injury and/or equipment damage.

3.1 Storing the Drive Before Installation

The drive should remain in the shipping container prior to installation. If the equipment is not to be used for a period of time, store it as follows:

- Use a clean, dry location
- Maintain the storage temperature and humidity as shown in the specifications section of this manual.
- Store it where it cannot be exposed to a corrosive atmosphere
- Store it in a non-construction area

3.2 Unpacking the Drive

Remove all packing material, wedges, and braces from within and around the components. After unpacking, check the name plate Material Number against the purchase order of the item(s) against the packing list. The model number, serial number and manufacturing date code are located on the side of the unit.

3.3 Handling an MMC Smart Drive

The case protects the MMC Smart Drive's internal circuitry against mechanical damage in shipping and handling.

However, like any electronic device, the circuitry can be destroyed by:

- Conditions exceeding those detailed in the specifications tables shown in the Specifications sections in this manual.
- moisture condensing inside the module
- static discharge
- exposure to a magnetic field strong enough to induce a current in the circuitry
- vibration, and other hazards

3.4 Inspecting the Drive Before Installation

Inspect the unit for any physical damage that may have been sustained during shipment.

If you find damage, either concealed or visible, contact your buyer to make a claim with the shipper. If degraded performance is detected when testing the unit, contact your distributor or Kollmorgen. Do this as soon as possible after receipt of the unit.

3.5 **Complying with European Directives**

For industrial products installed within the European Union or EEC regions, certain directives and standards apply. See “Conformity” in the Specifications sections of Chapters 5 and 6 for applicable directives.

Servo amplifiers are considered to be subsystems when incorporated into electrical plants and machines for industrial use. The Kollmorgen servo amplifiers have been designed and tested as such. They bear the CE mark and are provided with a Declaration of Conformance. However, it is the overall machine or system design that must meet European Directives and standards. To help the manufacturer of the machine or plant meet these directives and standards, specific guidelines are provided in this documentation. These include such things as shielding, grounding, filters, treatment of connectors and cable layout.

3.6 **Conforming with UL and cUL Standards**

Kollmorgen drives meet safety and fire hazard requirements as outlined in “Conformity” in the Specifications sections of [Chapter 13, *Declarations of Conformity*](#).

3.7 **General Installation and Ventilation Requirements**

- The drive must be enclosed in a grounded NEMA12 enclosure offering protection to IP55 such that they are not accessible to an operator or unskilled person, in order to comply with UL[®] and CE requirements. A NEMA 4X enclosure exceeds these requirements providing protection to IP66.
- The environmental conditions must not exceed those detailed in the specifications tables shown in the Specifications sections in this manual.
- Install the panel on a properly bonded, flat, rigid, non-painted galvanized steel, vertical surface that won't be subjected to shock, vibration, moisture, oil mist, dust, or corrosive vapors.
- Maintain minimum clearances for proper airflow, easy module access, and proper cable bend radius.
- Plan the installation of your system so that you can perform all cutting, drilling, tapping, and welding with the drive removed from the enclosure. Because the drive is of the open type construction, be careful to keep any metal debris from falling into it. Metal debris or other foreign matter can become lodged in the circuitry, which can result in damage to components.

The MMC Smart Drive is suitable for operation in a pollution degree 2 environment (i.e., normally, only non-conductive pollution occurs). Install the drive away from all sources of strong electromagnetic noise. Such noise can interfere with MMC Smart Drive operation.

Protect the MMC Smart Drive system from all the following:

- conductive fluids and particles
- corrosive atmosphere
- explosive atmosphere

Diagrams included with this manual and recommendations may be modified if necessary so the wiring conforms to current NEC standards or government regulations.

Table 3-1: Cabinet Clearance Dimensions		
Location	Minimum Clearance	
	230V Drive	460V Drive
Above Drive Body	2.0 in. (50.8 mm)	4.0 in. (100 mm)
Below Drive Body	2.0 in. (50.8 mm)	4.0 in. (100 mm)
Each Side of Drive	.50 in. (12.7 mm)	None
In Front of Drive (for cabling)	3.0 in. (76.2 mm)	3.0 in. (76.2 mm)

NOTE
Use filtered or conditioned air in ventilated cabinets. The air should be free of oil, corrosives, or electrically conductive contaminants.

3.8 Controlling Heat Within the System

The MMC Smart Drive hardware case is designed to promote air circulation and dissipate heat. Normally no fans or air conditioners are needed. However, if the environment outside the control cabinet is hot or humid, you may need to use a fan, heat exchanger, dehumidifier or air conditioner to provide the correct operating environment.

Make sure that the temperature and humidity within the drive cabinet does not exceed that which is shown in the specifications sections of this manual.

Make sure that components installed in the cabinet with the MMC Smart Drive do not raise the temperature above system limits and that any hot spots do not exceed specifications. For example, when heat-generating components such as transformers, other drives or motor controls are installed, separate them from the drive by doing one of the following:

- Place them near the top of the control cabinet so their heat output rises away from the MMC Smart Drive.
- Put them in another control cabinet above or to one side of the cabinet with the MMC Smart Drive. This protects the MMC Smart Drive from both heat and electrical noise.

The MMC Smart Drive itself is a source of heat, though in most installations its heat dissipates without harmful effects. System heat is generated from power dissipated by:

- the drive
- field side input/output components
- other drives in the cabinet
- the logic power supply

- external shunt resistors
- line reactors

CAUTION

If the MMC Smart Drive is operated outside the recommended environmental limits, it may be damaged. This will void the warranty.

3.9 Bonding

Connecting metal chassis, assemblies, frames, shields and enclosures to reduce the effects of electromagnetic interference (EMI) is the process of bonding.

Most paints act as insulators. To achieve a good bond between system components, surfaces need to be paint-free or metal plated. Bonding metal surfaces creates a low-impedance exit path for high-frequency energy. Improper bonding blocks this direct exit path and allows high-frequency energy to travel elsewhere in the cabinet. Excessive high-frequency energy can negatively affect the operation of the drive.

3.9.1 Bonding a Subpanel Using a Stud

1. Weld threaded mounting studs to the back of the enclosure.
2. Brush off any non-conductive materials (e.g. paint) from the studs.
3. Remove any non-conductive materials from the front of the subpanel.
4. Position the mounting holes on the subpanel over the mounting studs on the back of the enclosure and slide the subpanel onto the studs.
5. Attach the subpanel to the mounting stud by sliding a star washer over the stud and then turn and tighten a nut onto the stud.

3.9.2 Bonding a Ground Bus Using a Stud

1. Weld threaded mounting studs to the back of the subpanel.
2. Brush off any non-conductive materials (e.g. paint) from the studs.
3. Slide a flat washer over the studs.
4. Remove any non-conductive materials from around the mounting hole on the chassis mounting bracket or ground bus.
5. Position the mounting hole of the chassis or ground bus over the studs on the back of the subpanel and slide the mounting bracket or ground bus onto the stud.
6. Attach the subpanel to the subpanel stud by sliding a star washer and then a flat washer over the stud. Turn and tighten a nut onto the stud.

3.9.3 Bonding a Ground Bus or Chassis Using a Bolt

1. Brush off any non-conductive materials (e.g. paint) from the threaded bolt (s).
2. Slide a star washer over the threaded bolt (s).
3. Use a subpanel having tapped mounting holes. Remove any non-conductive materials from around the mounting holes on both sides of the subpanel.
4. Turn the threaded bolts into the subpanel mounting holes.

5. Slide a star washer onto the threaded end of the bolt.
6. Turn and tighten a nut onto the stud.
7. Slide a flat washer onto the threaded end of the bolt.
8. Position the mounting holes on the groundbus or mounting bracket over the threaded bolts and turn the bolts until they come through the grounding bus or mounting bracket.
9. Slide a star washer onto the threaded end of the bolt.
10. Slide a flat washer onto the threaded end of the bolt.
11. Turn and tighten a nut onto the bolt.

3.9.4 Grounding Multiple Drive Cabinets

1. Mount one bonded ground bus in each cabinet.
2. Designate the cabinet ground bus in one and only one of the cabinets as the common ground bus for all of the cabinets in the system.
3. Connect the ground wires from the ground bus in each individual cabinet ground bus to the designated common ground bus (mounted in only one of the cabinets).
4. Connect the common cabinet ground bus to an external ground system that is connected to a single point ground.

3.9.5 Bonding Multiple Subpanels

Kollmorgen recommends bonding both the top and bottom of subpanels sharing the same enclosure. Use a 25.4 mm (1.0 in.) x 6.35 mm (0.25) wire braid. Be sure the area around each wire braid fastener is clear of any non-conductive materials. Bond the cabinet ground bus to at least one of the subpanels.

NOTE
Subpanels that are not bonded together may not share a common low impedance path. This difference in impedance may affect networks and other devices that span multiple panels.

3.10 Drive Mounting Guidelines

- A control cabinet for the MMC Smart Drive should have a NEMA-12 rating or better. A cabinet with this rating protects its contents from dust and mechanical damage.
- The cabinet must be large enough to provide adequate air circulation for the MMC Smart Drive and other components. Always allow for adequate air flow through the MMC Smart Drive vents.
- The cabinet must have a rigid non-painted galvanized metal surface to mount the MMC Smart Drive on.

- The cabinet door should open fully for easy access.

IMPORTANT
Post warnings according to National, State, or local codes for the voltage present in the control cabinet. Diagrams included with this manual and recommendations may be modified if necessary so the wiring conforms to current NEC standards or government regulations.

NOTE
This drive contains parts and assemblies that are sensitive to ESD (Electrostatic Discharge). Follow static control precautions during installation, testing, service, or repair of this assembly. Parts and assemblies can be damaged if proper precautions are not taken.

1. Lay out the positions for the drive and accessories in the enclosure.
2. Attach the drive to the cabinet, first using the upper mounting slots of the drive and then the lower. The recommended mounting hardware is M5 metric(#10-32).
3. Tighten all mounting fasteners.

3.11 Drive System Grounding Procedures

The ground of the MMC Smart Drive power source must be connected directly to a **Single Point Ground (SPG)** tie block. The tie block should be made of brass or copper, bolted or brazed to the control cabinet. If the tie block is bolted rather than brazed, scrape away paint or grease at the point of contact. Put star washers between the tie block and the cabinet to ensure good electrical contact.

Metal enclosures of power supplies, drives, etc., should also have good electrical contact with the SPG.

Metal enclosures of power supplies, drives, etc., should also have good electrical contact with the SPG.

CAUTION
The Single Point Ground should be the only common point for all the ground lines. If not, ground loops may cause current flow among components of the system which can interfere with proper operation of the MMC Smart Drive.

Devices to be connected directly to the Single Point Ground include:

- Plant safety ground.
- Protective earth ground(s) from the MMC Smart Drive power terminals.
- The metal panel or cabinet on which the MMC Smart Drive is mounted.
- “Common” or “0 V” lines from power supplies that provide +24 power to devices and external power to the I/O modules and the devices to which they are connected.

- Protective grounds from the devices themselves, such as device drivers, machinery, and operator interface devices.
- Protective earth ground from line and load sides of any AC line filters.
- The ground of the power source of the computer workstation or laptop, if any, from which you monitor the system operation. An AC outlet in the control cabinet is recommended.
- Single point grounds from other control cabinets, if any, in the system.

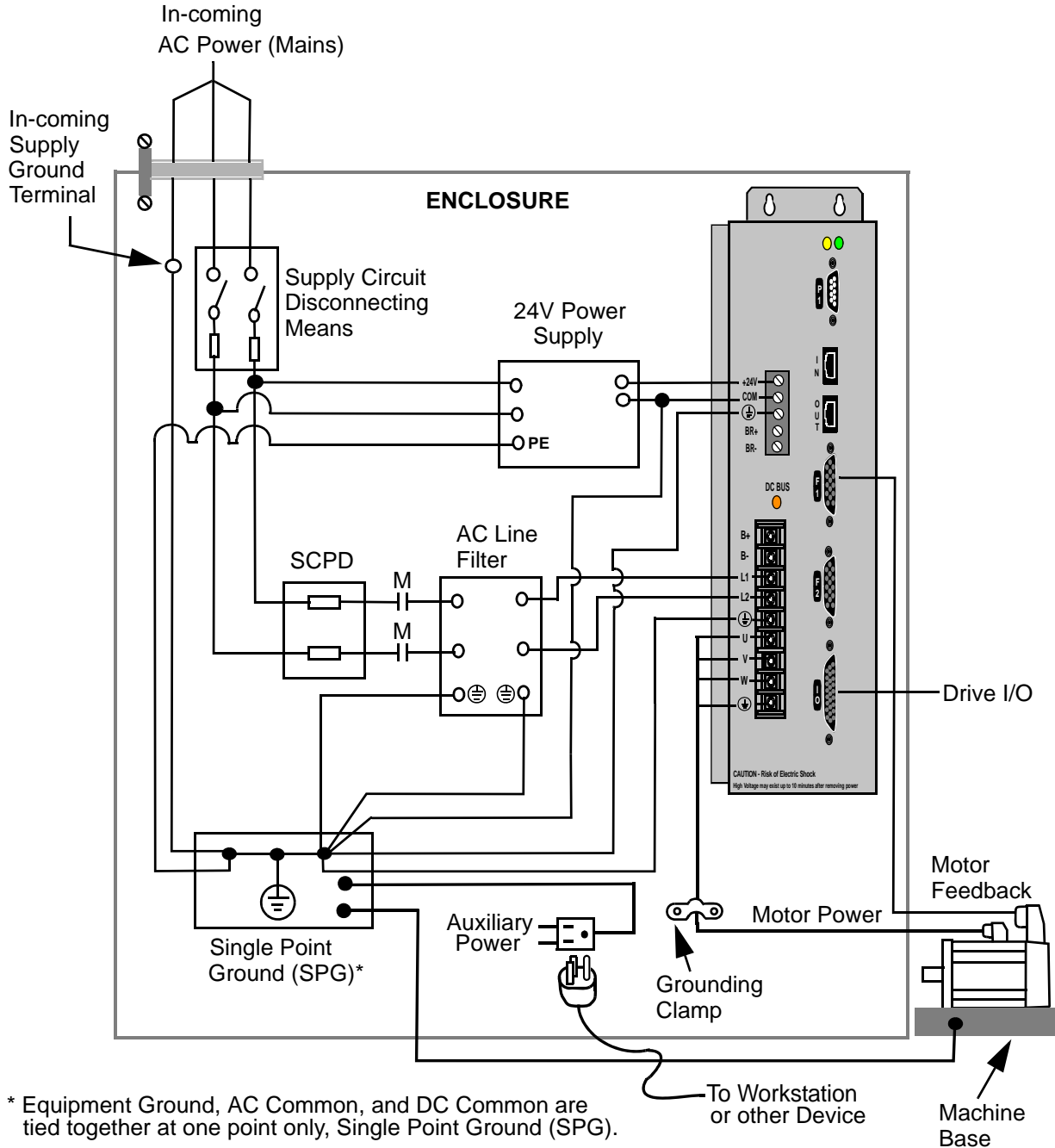
IMPORTANT

You must ensure that the “0V” or “Common” of all devices connected to the MMC Smart Drive are connected to Single Point Ground (SPG). Failure to do so may result in erratic operation or damage to the MMC Smart Drive and devices connected to it. Examples of devices connected to the MMC Smart Drive include the power source that supplies power to the MMC Smart Drive and devices connected to the MMC Smart Drive PiCPro Port. Note that some devices (for example, a Personal Computer) may have their “0V” and “Protective Earth Ground” connected together internally, in which case only one connection has to be made to SPG for that device. Also note that the AC/DC converter for some portable PCs have chassis connected from the wall plug to the PC. The ground for the AC outlet must be connected to the SPG.

Also, you must ensure that the MMC Smart Drive “Protective Earth Ground” connection is connected to SPG, and that the MMC Smart Drive is mounted to a metal panel or enclosure that is connected to SPG.

3.11.1 Grounding Requirements

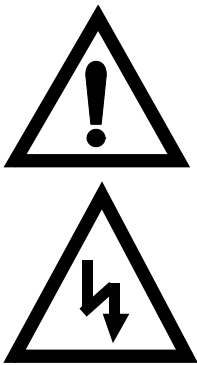
Figure 3-1: Example of Grounding Required for CE Compliant Single Phase 230V Drive System



- Mount the filter as close to the Drive as possible. If the distance exceeds 600 mm (2.0 ft), use shielded cable between the Drive and the filter, strapping the shield to chassis at each end of the cable. This is particularly important for attenuation of higher frequency emissions (5-30 MHz).

- Shield or separate the wires connecting the AC power to the filter from other power cables (e.g., connections between the Drive and the filter, motor power cable, etc.). If the connections are not separated from each other, the EMI on the Drive side of the filter can couple over to the source side of the filter, thereby reducing or eliminating the filter’s effectiveness. The coupling mechanism can radiate or allow stray capacitance between the wires.
- Bond the filter and the Drive to a grounded conductive surface (the enclosure) to establish a high frequency (HF) connection. To achieve the HF ground, the contact surface interface between the filter, Drive, and the enclosure should be free from paint or any other type of insulator.
- Size the filter following manufacturer recommendations.
- Provide a large enough ground bar to connect all wires with no more than two wires per connection.
- Clamp motor power cable shield for EMC termination.

IMPORTANT
Filter AC power to the drives to be compliant to CE emission requirements.

WARNING	
	<p>High voltage exists in AC line filters. The filter must be grounded properly before applying power. Filter capacitors retain high voltages after power removal. Before handling the equipment, voltages should be measured to determine safe levels. Failure to observe this precaution could result in personal injury.</p>

3.11.2 Grounding Multiple Drives in the Same Cabinet

1. Mount a common bonded ground bus in the cabinet.
2. Connect the ground wires for all drives to the common bonded cabinet ground bus.
3. Connect the common bonded cabinet ground bus to an external ground system that is connected to a single point ground.

3.12 System Wiring Guidelines

The MMC Smart Drive relies on electrical signals to report what is going on in the application and to send commands to it. In addition, signals are constantly being

exchanged within the system. The MMC Smart Drive is designed for use in industrial environments, but some guidelines should be followed.

This section contains common system wiring configurations, size, and practices that can be used in a majority of applications. National Electrical Code, local electrical codes, special operating temperatures, duty cycles, or system configurations take precedence over the values and methods provided.


Wherever possible, install wiring and related components in the following order:

1. main power line disconnecting means
2. transformer (optional)
3. fuses (SCPD)
4. motor control
5. line reactor (as required)
6. line filter (optional)
7. device protection fuses (as required)
8. drive
9. shunt resistors (optional)

3.12.1 Recommended Signal Separation

Kollmorgen recommends separation of low level signals (encoder, analog, communications, fast DC inputs) from high voltage or high current lines. Maintain at least two inches of separation.

Inside a control cabinet, connect the shields of shielded cables at the MMC Smart Drive. It is recommended that factory cables (from Kollmorgen) are used between MMC drives, controls, and motors to ensure CE compliance.

WARNING	
	Use care when wiring I/O devices to the MMC Smart Drive and when plugging in cables. Wiring the wrong device to the connector or plugging a connector into the wrong location could cause intermittent or incorrect machine operation or damage to equipment.


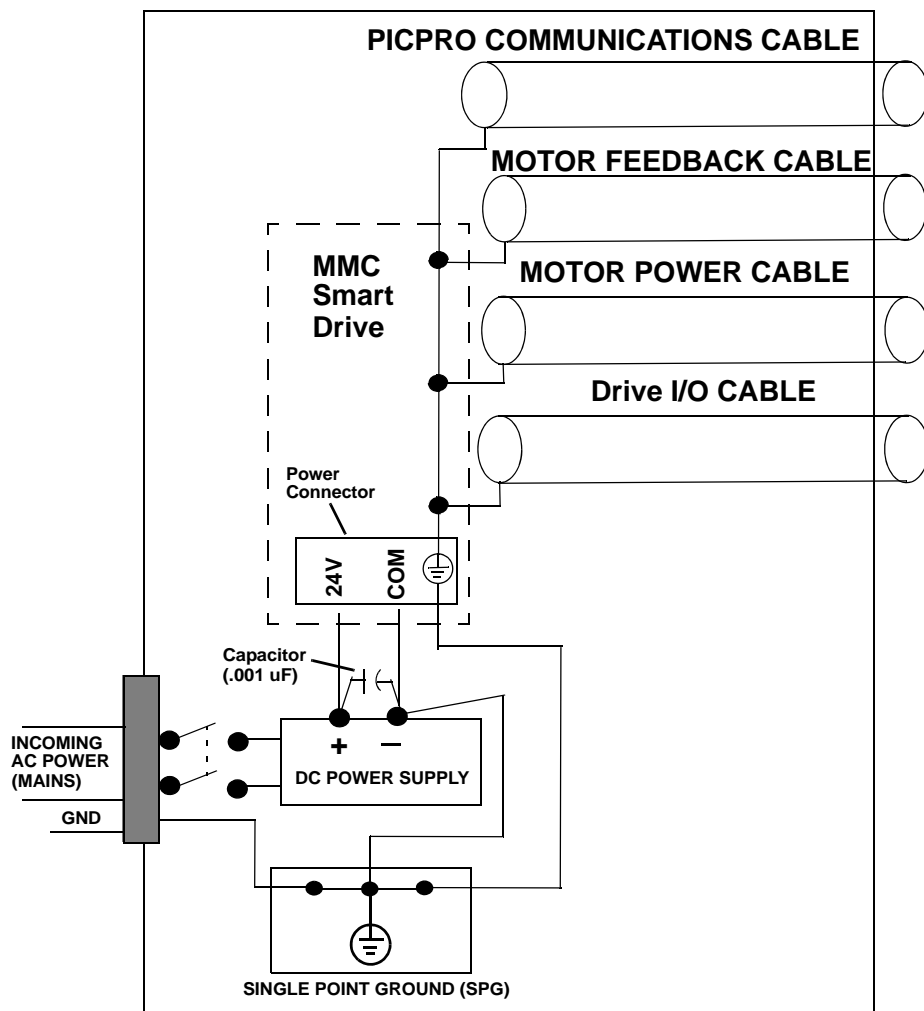
WARNING: FEEDBACK DEVICE DAMAGE	
	<p>Feedback Cable Installation and Removal</p> <p>All power to the Smart Drive (24 Vdc and main AC power) must be removed before connecting/disconnecting feedback cable connectors at the Smart Drive (F1 and F2 connector) or at the motor feedback device. Also, all connections must be secure when power is applied. Failure to follow these precautions may result in damage to the feedback device or Smart Drive.</p>

Figure 3-2: Recommended Signal Separation



To prevent excessive conducted emissions from a DC power source (typically 24V) used for digital I/O, a .001 micro farad capacitor should be used. Connect the capacitor from the +24V DC to COMMON at the distribution terminals.

3.12.2 Building Your Own Cables

- Connect the cable shield to the connector shells on both ends of the cable for a complete 360 degree connection.
- Use a twisted pair cable whenever possible, twisting differential signals with each other, and single-ended signals with the appropriate ground return.

NOTE
Kollmorgen cables are designed to minimize EMI and are recommended over hand-built cables.

3.12.3 Routing Cables

Guidelines for routing cables in a cabinet include the following:

- Always route power and control cables separately.
- Do not run high and low voltage wires/cable in the same wireway.
- Cross high and low voltage conductors at 90 degree angles.
- On parallel cable runs, maximize the distance between high and low voltage cables.
- Maintain the least amount of unshielded cable leads.

3.13 Wiring the Drive

These procedures assume you have bonded and mounted your MMC Smart Drive to the subpanel and that there is no power applied to the system.

3.13.1 Sizing the 24V Power Supply

When you size your power supply, you must ensure that the supply is large enough to handle the total load. Refer to the specification tables for the +24VDC input power requirements.

In most cases, one power supply can be used for an entire control system. However, depending upon the drives and external I/O used in the application, the power distribution may be split into two or more power supplies.

Use of switches in series with the 24VDC power input is not recommended. The drive contains energy storage capacitors at the inputs. While no harm is done to the drive, this much capacitance across the 24VDC source may cause voltage dips when the switch in series with the 24VDC power is closed.

CAUTION

A possible ignition hazard within the MMC Smart Drive exists if excessive current is drawn from the 24 VDC powering the MMC Smart Drive. To prevent this possibility (due to improper wiring or 24 VDC supply failure), a fuse should be used in series with the 24 VDC to the MMC Smart Drive. Specifically, a 4 A max. "UL248 Series" fuse should be used. In addition, the 24 VDC shall be supplied by an isolating source such that the maximum open circuit voltage available to the MMC Smart Drive is not more than 30 VDC.

The +24V power to the MMC Smart Drive is connected through a Phoenix 5-pin connector with a plug-in terminal block. The ground from the power source and the ground from the MMC Smart Drive must be connected to the Single-Point Ground (SPG). Devices connected to the Drive I/O Port may have their own power sources for input or output control signals provided that each one is:

- at the correct voltage and current levels for the module and the device.
- connected to the same Single-Point Ground that the MMC Smart Drive uses.

It is recommended that the same main disconnect switch be used for the MMC Smart Drive and for all devices in the application.

IMPORTANT

No matter how the system is installed, before you connect the MMC Smart Drive to the application, make sure that power is off to the system and to the devices that are wired to the MMC Smart Drive.

3.13.2 System AC Power Wiring Guidelines

NOTE

In addition to the guidelines listed below, follow all national and local electrical codes and regulations.

- Install a supply circuit disconnecting means.
- Install a Short Circuit Protective Device (SCPD).
- Due to high inrush current at power-up, use dual element time delay fuses for the SCPD.
- Install additional device protection fusing (460V models). Only high speed type fuses provide proper protection.
- Refer to the Specifications sections in Chapter 4 of this manual for device and conductor requirements.
- Clamp the motor power cable shield to the drive using the Kollmorgen supplied bracket. Maximum tightening torque for bracket screws is 10 lb-in.

- Use shielded cables and AC line filters (for CE Compliance). Make sure that wiring from the drive to the line filter is as short as possible. Locate common grounding bus bars as close as possible to the drive. The braid shield of the cable should be clamped at the drive or mounting panel.
- Power connections for each drive in a system should be separately connected directly to the AC power supply. Do not daisy chain drive power connections.
- Make sure the phase to neutral ground voltage does not exceed the input ratings of the drive when using an autotransformer.

3.13.3 Connecting Interface Cables

IMPORTANT

This drive contains ESD (Electrostatic Discharge) sensitive parts and assemblies. Follow static control precautions when installing, testing, servicing, or repairing components in a drive system.


- Plug PiCPro cable into the PiCPro port (9-pin D-shell for the Analog Interfaced MMC-SD, and 6-pin mini-din for the Digital Interfaced MMC-SD).
- Plug the one 15-pin D-shell, Feedback cable into the FBK1 connector.
- Plug the 26-pin D-shell, Drive I/O cable into the I/O connector.
- Tighten the attachment screws for all cables to the drive connectors.

WARNING



To avoid personal injury and/or equipment damage:

- Ensure installation complies with specifications regarding wire types, conductor sizes, branch circuit protection, and disconnect devices. The National Electrical Code (NEC) and local codes outline provisions for safely installing electrical equipment.
- Ensure motor power connectors are used for connection purposes only. Do not use them to turn the unit on and off.
- To avoid personal injury and/or equipment damage, ensure shielded power cables are grounded to prevent potentially high voltages on the shield.

WARNING: FEEDBACK DEVICE DAMAGE	
	<p>Feedback Cable Installation and Removal</p> <p>All power to the Smart Drive (24 Vdc and main AC power) must be removed before connecting/disconnecting feedback cable connectors at the Smart Drive (F1 and F2 connector) or at the motor feedback device. Also, all connections must be secure when power is applied. Failure to follow these precautions may result in damage to the feedback device or Smart Drive.</p>

3.13.4 Preparing Motor Connection Wires

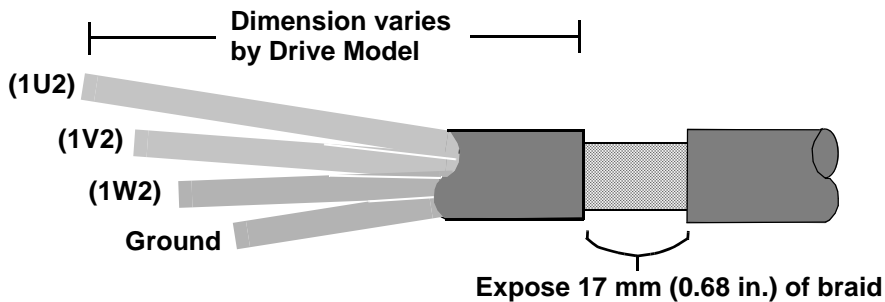
NOTE
<p>It is recommended that Kollmorgen cables be used. Kollmorgen cables are designed to minimize EMI and are recommended over hand-built cables.</p>

1. Strip back cable jacket approximately 152 mm (6.0 in.) from the end of the cable.
2. Strip approximately 12 mm (0.50 in.) of insulation from the end of each conductor. Do not tin ends after stripping.

IMPORTANT
<p>Do not nick, cut or damage wire strands while removing wire insulation.</p>

3. Strip the cable jacket away from the cable until the shield braid is visible. Expose 17 mm (0.68 in.) of cable shield braid.

Figure 3-3: : Motor Cable



4. Attach the individual wires from the motor cable to their assigned terminal. Refer to Chapters 5 and 6 for front panel connectors and terminal assignments.
5. Tighten each terminal screw.

6. Gently pull on each wire to make sure it does not come out of its terminal. Reinsert and tighten any loose wires.
7. Attach the plastic cover to terminal block

Factory supplied motor power cables for LSM, MSM, FSM, AKM, DDR, CDDR, and YSM Series motors are shielded, and the power cable is designed to be terminated at the drive during installation. A small portion of the cable jacket is removed which exposes the shield braid. The exposed shield braid must be clamped to the drive chassis using the provided clamp and clamp screws

Figure 3-4: Terminating Motor Power Cable for 230V Drive

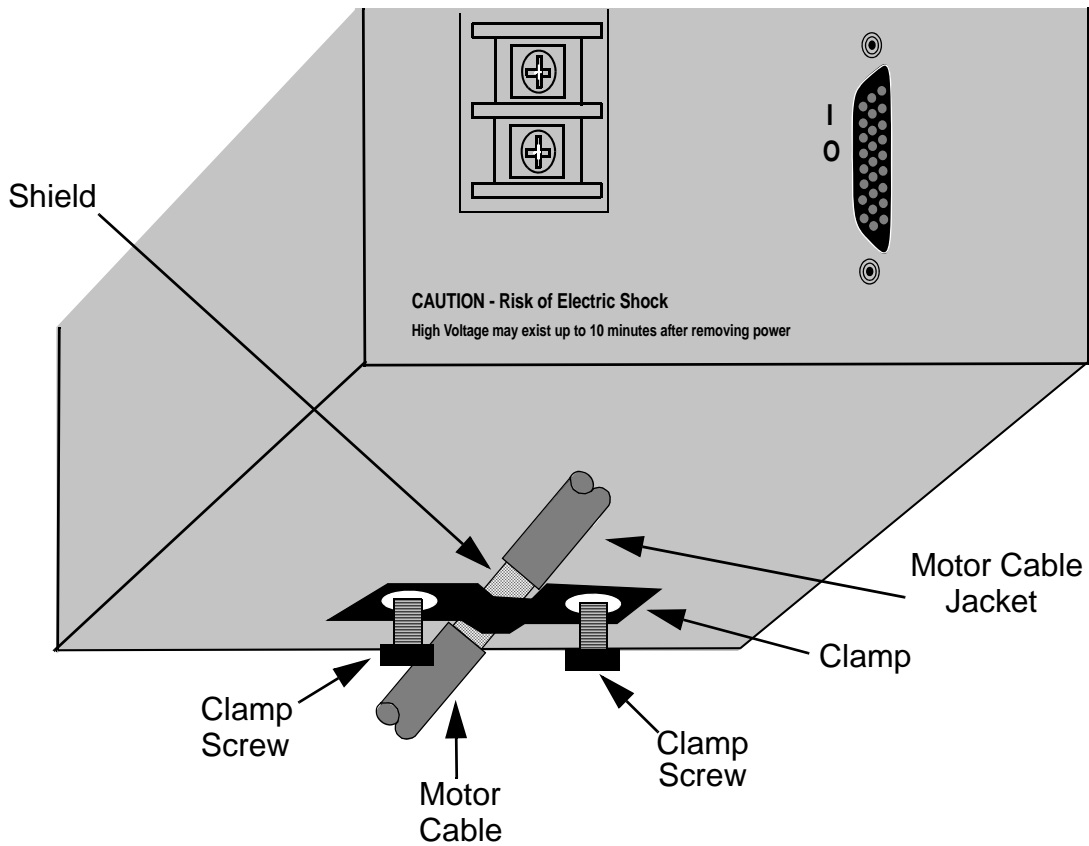
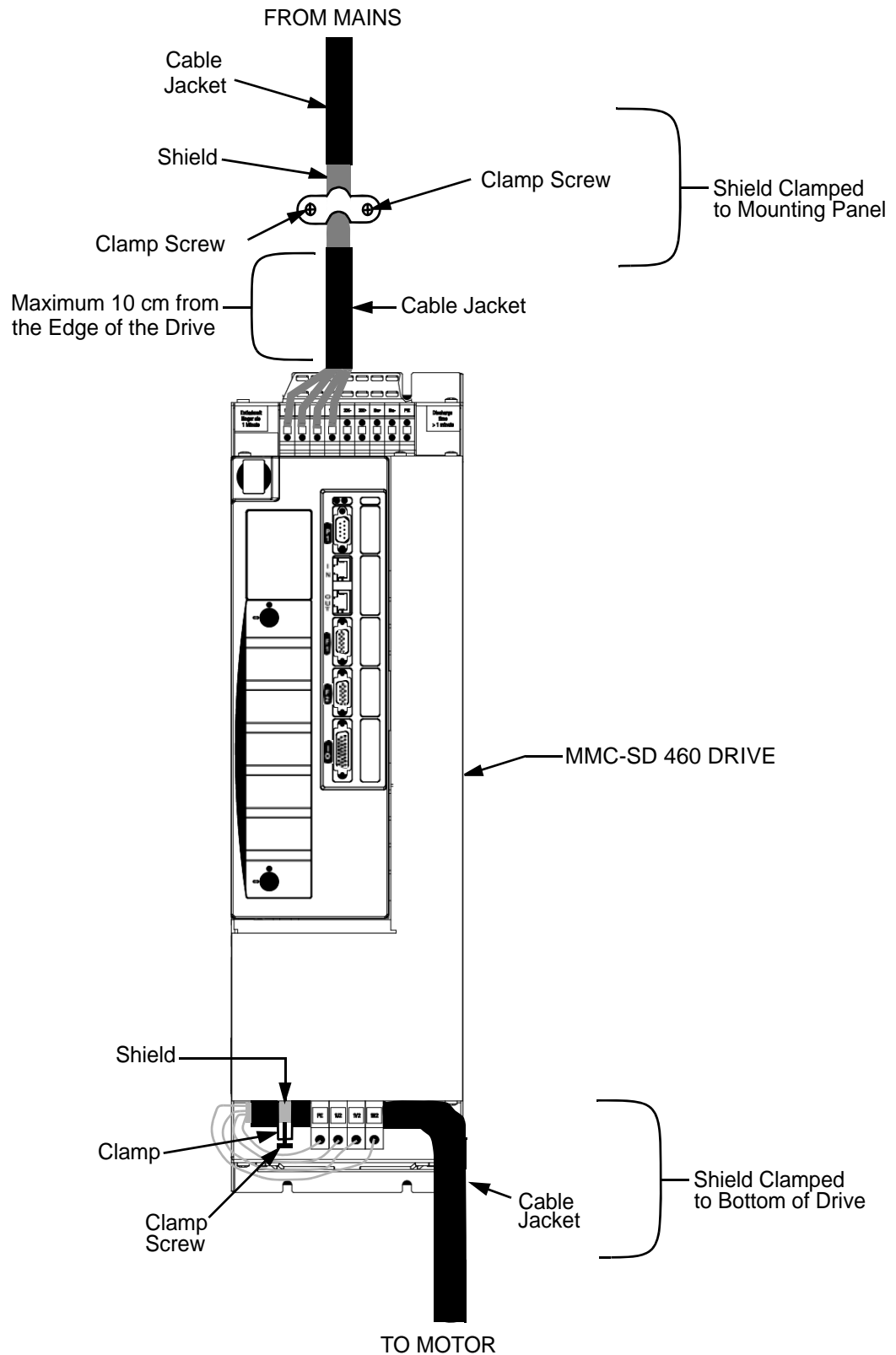


Figure 3-5: Terminating Incoming AC Power (Mains) Cable for 460V Drive



4 System Power Protection and Related Devices

4.1 AC Input Power Requirements

The MMC Smart Drive is powered from an external AC power source. The power required for each drive type is listed in [Table 4-1](#).

Table 4-1: AC Input Power Requirements				
Drive Model ^a	Requirements			
	Nominal Input Current (Amps _{RMS})		Transformer (kVA) ^b	
230 Volt Drives ^a	Input Voltage = 120VAC	Input Voltage = 230VAC	Input Voltage = 120VAC	Input Voltage = 230VAC
MMC-SD-0.5-230	5	5	.5	1
MMC-SD-1.0-230	9	9	1	2
MMC-SD-2.0-230	18	18	2	4
460 Volt Drives ^a	Input Voltage = 230VAC	Input Voltage = 460VAC	Input Voltage = 230VAC	Input Voltage = 460VAC
MMC-SD-1.3-460	2.8	2.44	1.2	3.0
MMC-SD-2.4-460	4.8	4.18	2.0	5.0
MMC-SD-4.0-460	8.1	7.0	3.4	8.5
MMC-SD-6.0-460	12.4	10.8	5.2	12.8
MMC-SD-8.0-460	17.0	14.8	7.0	17.6
MMC-SD-12.0-460	19.2	16.7	8.0	19.5
MMC-SD-16.0-460	24.2	21.1	10.0	25.0
MMC-SD-24.0-460	38.0	33.1	16.0	39.5
MMC-SD-30.0-460	53.0	46.0	22.0	55.0
MMC-SD-42.0-460	70.0	70.0	29.0	73.0
MMC-SD-51.0-460	84.0	73.0	35.0	87.0
MMC-SD-65.0-460	105	91.0	44.0	110

- a. Drive Model pertains to Analog (no dash suffix) and digital (-D & -DN)
- b. See [section 4.4 on page 47](#) for calculating application transformer requirement

4.2 Protection

4.2.1 Motor Overload Protection

The MMC Smart Drive utilizes solid state motor overload protection in accordance with UL508C that operates:

- within 8 minutes at 200% overload
- within 20 seconds at 600% overload

4.2.2 Motor Thermal Protection

The motor may be supplied with one of the following thermal protectors:

- A thermostat (normally closed, contacts rated at 10ma or greater). The thermostat's contact will open when the motor's maximum operating temperature is exceeded. Connect the thermostat between 0V and pin 11 of the drive's Feedback Connector (F2).
- A thermistor (Phillips KTY84-130 PTC or equivalent recommended). The motor manufacturer will provide the motor's maximum operating temperature. This temperature may be entered into the Motor Temperature Parameters in PiCPro. Connect the thermistor output to pin 11 of the drive's Feedback Connector (F2).

4.2.3 230V Smart Drive Protection Requirements

Two types of Protection must be provided in case the Smart Drive malfunctions:

- Short Circuit Protection - this protection helps minimize damage to the Smart Drive in the case of a Short Circuit condition. Short Circuit Protection is required to meet UL508C requirements.
- Branch Circuit Over Current Protection - this protection helps minimize damage to the Smart Drive and helps protect the wiring between the Smart Drive and the Over Current Protection Device in the case of a sustained Over Current condition. Over Current Protection must be provided in accordance with NFPA 79 7.2.3 and 7.2.10. Supplemental UL1007 protectors **shall not** be used to provide Branch Circuit Protection.

When using the 230V Smart Drive, the fuse that provides Short Circuit Protection also provides Over Current Circuit Protection, therefore a separate Short Circuit Protection fuse is not required.

Two types of fuses are defined for use with the 230V Smart Drive:

Non-restricted - If the Branch Circuit supplying power to the drive is capable of delivering no more than 5,000 RMS symmetrical short circuit amperes (240V maximum), the fuse type provided for Protection has no "Clearance I^2t " restrictions, and must meet the following requirements:

- have a current rating no greater than the "Maximum Fuse Size" in [Table 4-2](#)
- have an interrupt capability no less than the short circuit rating (Prospective Short-circuit Symmetrical Amperes) of the Branch Circuit supplying the drive.

Restricted - If the Branch Circuit supplying power to the drive is capable of delivering between 5,000 and 100,000 RMS symmetrical short circuit amperes (240V maximum), the fuse type provided for Protection has “Clearance I^2t ” restrictions, and must meet the following requirements:

- meet both of the requirements for a non-restricted fuse (above)
- be a Class RK1, J, or CC dual element current limiting fuse

230V Drive Model ^a	Maximum Fuse Size ^b	
	V _{IN} = 120VAC	V _{IN} = 230VAC
MMC-SD-0.5-230	12A	12A
MMC-SD-1.0-230	15A	15A
MMC-SD-2.0-230	30A	30A

a. Drive model pertains to Analog (no dash suffix) and Digital (-D & -DN) versions

b. This is the maximum fuse size that can be used for Device Protection

4.2.4 460V Smart Drive Protection Requirements

Two types of Protection must be provided in case the Smart Drive malfunctions:

- Short Circuit Protection - this protection helps minimize damage to the Smart Drive in the case of a Short Circuit condition. Short Circuit Protection is required to meet UL508C requirements.
- Branch Circuit Over Current Protection - this protection helps minimize damage to the Smart Drive and helps protect the wiring between the Smart Drive and the Over Current Protection Device in the case of a sustained Over Current condition. Over Current Protection must be provided in accordance with NFPA 79 7.2.3 and 7.2.10. Supplemental UL1007 protectors **shall not** be used to provide Branch Circuit Protection.

Two types of fuses are defined for use with the 460V Smart Drive:

Non-restricted - If the Branch Circuit supplying power to the drive is capable of delivering no more than 5,000 RMS symmetrical short circuit amperes (480V maximum), the fuse type provided for Protection has no “Clearance I^2t ” restrictions, and must meet the following requirements:

- have a current rating no greater than the “Maximum Fuse Size” in [Table 4-3](#)
- have an interrupt capability no less than the short circuit rating (Prospective Short-circuit Symmetrical Amperes) of the Branch Circuit supplying the drive.

Restricted - If the Branch Circuit supplying power to the drive is capable of delivering between 5,000 and 100,000 RMS symmetrical short circuit amperes (480V maximum), the fuse type provided for Protection has “Clearance I^2t ” restrictions, and must meet the following requirements:

- meet both of the requirements for a non-restricted fuse (above)

- have a “Clearance I^2t ” rating no greater than the “Clearance I^2t ” rating in [Table 4-3](#)

The requirements for both restricted and non restricted fuses may be met by using one of two methods:

- Use a single fuse that meets all requirements. The easiest way to accomplish this is to use a “Combination Fuse” from [Table 4-3](#). These fuses meet all of the requirements for both Short Circuit Protection and Over Current Protection, and may be used on Branch Circuits that supply up to 100,000 RMS symmetrical short circuit amperes (480V maximum).
- Use two fuses connected in series, that, in combination, meet all of the requirements:
 - Use an Over Current Protection fuse that has a current rating not greater than the “Maximum Fuse Size” shown in [Table 4-3](#), and an interrupt capability not less than the short circuit rating (Prospective Short-circuit Symmetrical Amperes) of the Branch Circuit supplying the drive.
 - Use a Short circuit Protection fuse (typically a semiconductor fuse) that has a “Clearance I^2t ” rating not greater than that shown in [Table 4-3](#), and a current rating greater than the Over Current Protection fuse (to avoid nuisance tripping).

Table 4-3: 460V Smart Drive Protection Devices					
460V Drive Model ^a	I^2t Rating ^b	Maximum Fuse Size ^c		Ferraz (Bussmann) Combination Fuse ^{d,e}	
		$V_{IN} = 230VAC$	$V_{IN} = 460VAC$	$V_{IN} = 230VAC$	$V_{IN} = 460VAC$
460 Volt Drives ^a		$V_{IN} = 230VAC$	$V_{IN} = 460VAC$	$V_{IN} = 230VAC$	$V_{IN} = 460VAC$
MMC-SD-1.3-460	$< 228A^2s$	11A	9A	HSJ6(DFJ6)	HSJ6(DFJ6)
MMC-SD-2.4-460	$\leq 228A^2s$	19A	16A	HSJ15(DFJ15)	HSJ15(DFJ15)
MMC-SD-4.0-460	$\leq 260A^2s$	32A	27A	HSJ15(DFJ15)	HSJ15(DFJ15)
MMC-SD-6.0-460	$\leq 340A^2s$	49A	41A	HSJ20(DFJ20)	HSJ20(DFJ20)
MMC-SD-8.0-460	$\leq 616A^2s$	68A	56A	HSJ30(DFJ30)	HSJ25(DFJ25)
MMC-SD-12.0-460	$\leq 1, 555A^2s$	76A	64A	HSJ35(DFJ35)	HSJ30(DFJ30)
MMC-SD-16.0-460	$\leq 1, 555A^2s$	96A	80A	HSJ40(DFJ40)	HSJ35(DFJ35)
MMC-SD-24.0-460	$\leq 1, 555A^2s$	152A	126A	HSJ60(DFJ60)	HSJ45(DFJ45)
MMC-SD-30.0-460	$\leq 15,000A^2s$	212A	176A	N/A ^f (DFJ80)	N/A ^f (DFJ60)
MMC-SD-42.0-460	$\leq 15,000A^2s$	280A	233A	HSJ125(DFJ125)	HSJ100(DFJ100)
MMC-SD-51.0-460	$\leq 83,700A^2s$	336A	280A	HSJ150(DFJ150)	HSJ110(DFJ110)
MMC-SD-65.0-460	$\leq 83,700A^2s$	420A	350A	HSJ175(DFJ175)	HSJ125(DFJ125)

- a. Drive model pertains to analog (no dash suffix) and Digital (-D)
- b. This is the maximum “Clearance I^2t Rating” of a fuse used for Device Protection. Use a fuse that falls in the operating point below the stated release integral (I^2t). All of the listed “Combination Fuses” meet this requirement.
- c. This is the maximum fuse size that can be used for Device and Branch Circuit Protection
- d. Kollmorgen part numbers for these fuses can be found in [Section 12.4](#)
- e. Listed devices are UL Recognized. These fuses have an Interrupt current of 100,000A
- f. Combination fuse not available from Ferraz for this drive

4.3 Line Reactors

AC Line Reactors are required when using some models of the MMC Smart Drive. They protect the drive from impermissible rates of current change and reduce harmonic current distortions. When required, they are mounted between the drive and the mains input power source.

NOTE
<p>Multiple drives or inverters on a common power line require one reactor per drive. Individual reactors provide filtering between each drive (and thereby reduce crosstalk) and also provide optimum surge protection for each unit. A single reactor serving several drives does not provide adequate protection, filtering or harmonic reduction when the system is partially loaded. Refer to Figure 4-1 for an example of one line reactor connected to one drive.</p>

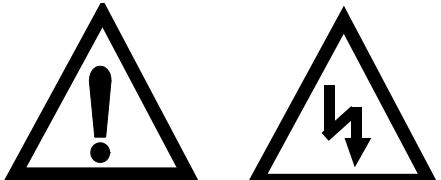
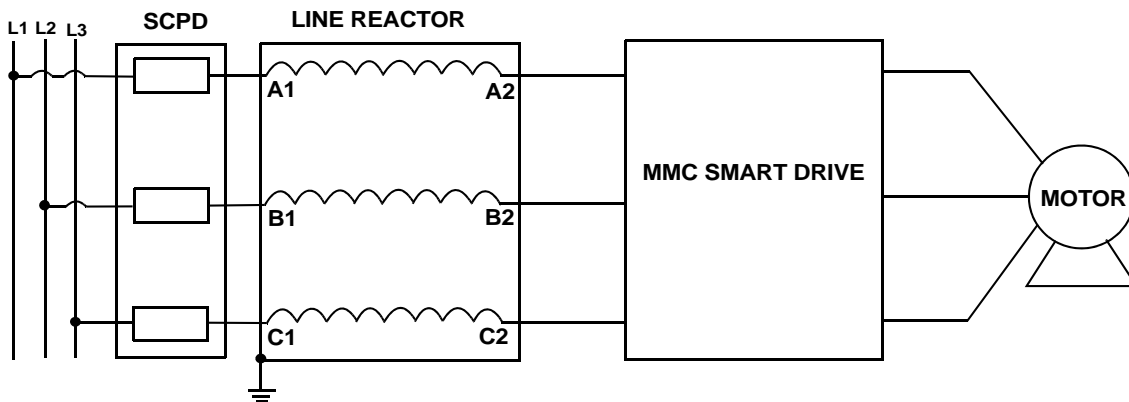
WARNING

<p>Danger Electric Shock Risk</p>
<p>The frame of line/load reactors must be grounded at one of the reactor mounting holes typically by using a star washer under the heads of the mounting bolts. INJURY OR DEATH MAY RESULT IF THESE SAFETY PRECAUTIONS ARE NOT OBSERVED.</p>

Figure 4-1: Line Reactor Connection (Simplified)



Line reactors are not necessary for the 230V MMC Smart Drives or the 460V size 1 and 2 MMC Smart Drives. Line reactors are required for the 460V size 3 and size 4 MMC Smart Drives.

4.3.1 Specifications and Dimensions for Required Line Reactors

Table 4-4: MMC-SD-12-460 Line Reactor Specifications				
Fundamental Amperage	Power Loss	Inductance	Weight	Part Number
25A	52W	1.2 mH	14 lbs.	M.1302.7373

0.38 x 0.75
(4 SLOTS)

3.00

3.43
MAX

2.35

LABEL

WIRE RANGE: 22-5 AWG

CAUTION - TERMINAL SCREW TIGHTENING
TORQUE: 16 in-lb MAX

6.00
MAX

7.25
MAX

Table 4-5: MMC-SD-16-460 Line Reactor Specifications				
Fundamental Amperage	Power Loss	Inductance	Weight	Part Number
35A	54W	0.8 mH	16 lbs.	M.1302.7374

0.38 x 0.75 (4 SLOTS)

3.00

4.00 MAX

2.63

LABEL

WIRE RANGE: 22-5 AWG

CAUTION - TERMINAL SCREW TIGHTENING TORQUE: 16 in-lb MAX

5.75 MAX

7.25 MAX

Table 4-6: MMC-SD-24-460 Line Reactor Specifications

Fundamental Amperage	Power Loss	Inductance	Weight	Part Number
45A	62W	0.7 mH	28 lbs.	M.1302.7375

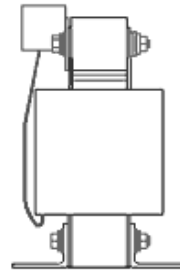
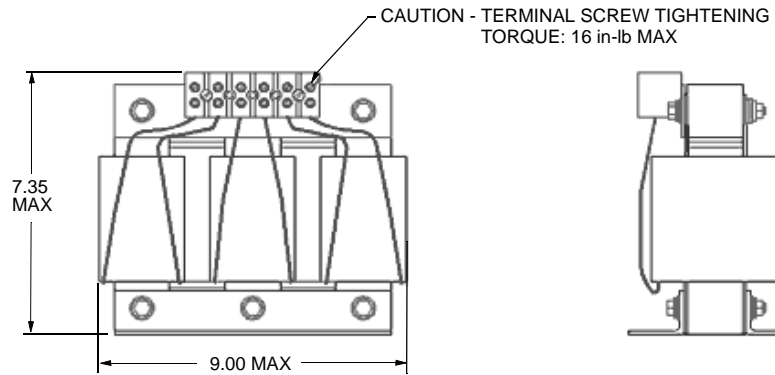
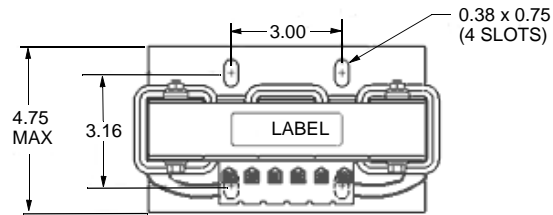
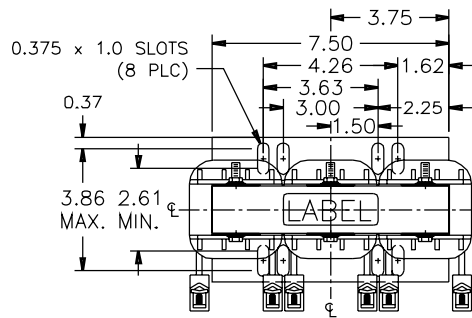


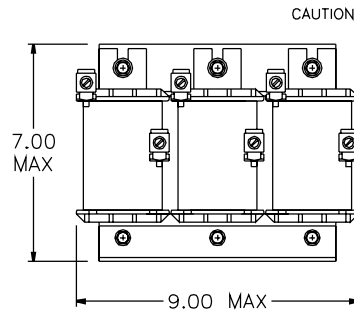
Table 4-7: MMC-SD-30-460 Line Reactor Specifications

Fundamental Amperage	Power Loss	Inductance	Weight	Part Number
55A	67W	0.5 mH	27 lbs.	M.3000.0105



WIRE RANGE: 6-0 AWG

NOTE:
CENTER LINE REPRESENTS
CENTER OF REACTOR CORE



CAUTION-TERMINAL SCREW TIGHTENING
TORQUE: 6-4 (45) in-lb MAX.
2-0 (50) in-lb MAX.

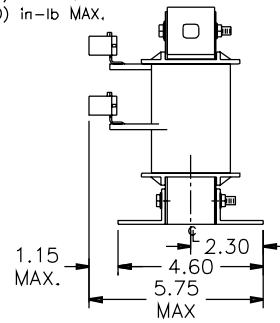


Table 4-8: MMC-SD-42-460 Line Reactor Specifications

Fundamental Amperage	Power Loss	Inductance	Weight	Part Number
80A	86W	0.4 mH	51 lbs.	M.3000.0106

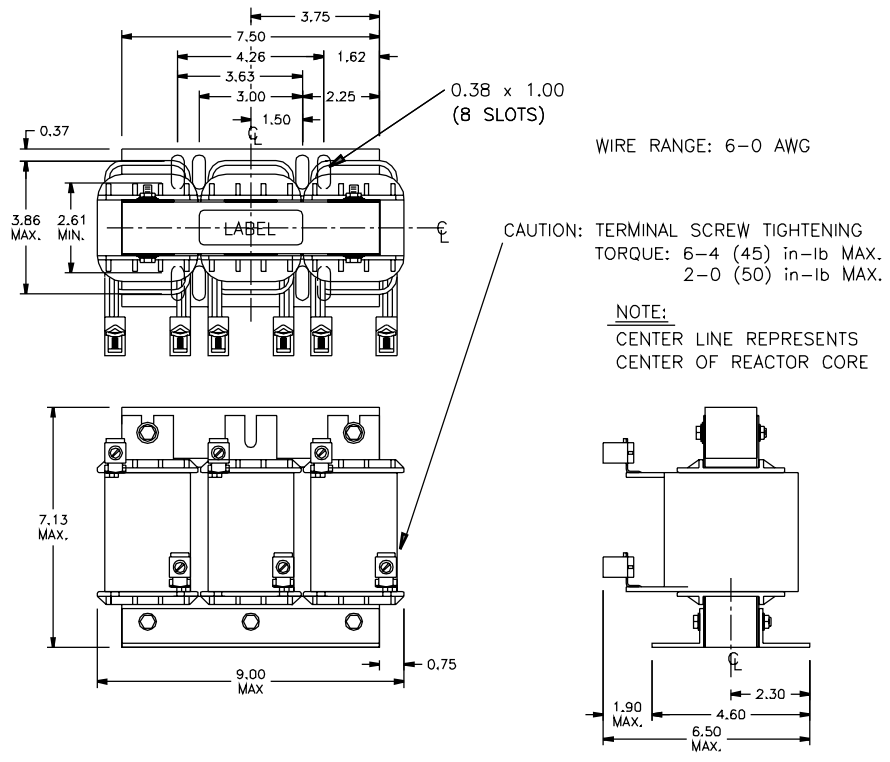
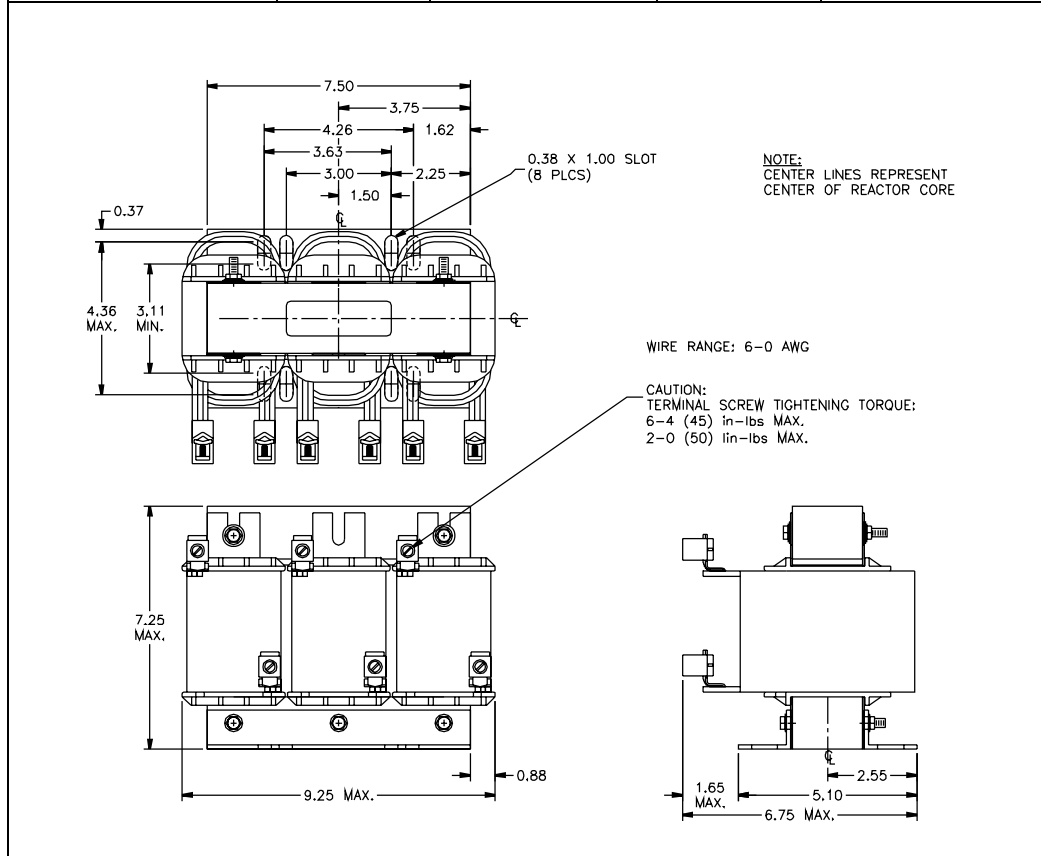
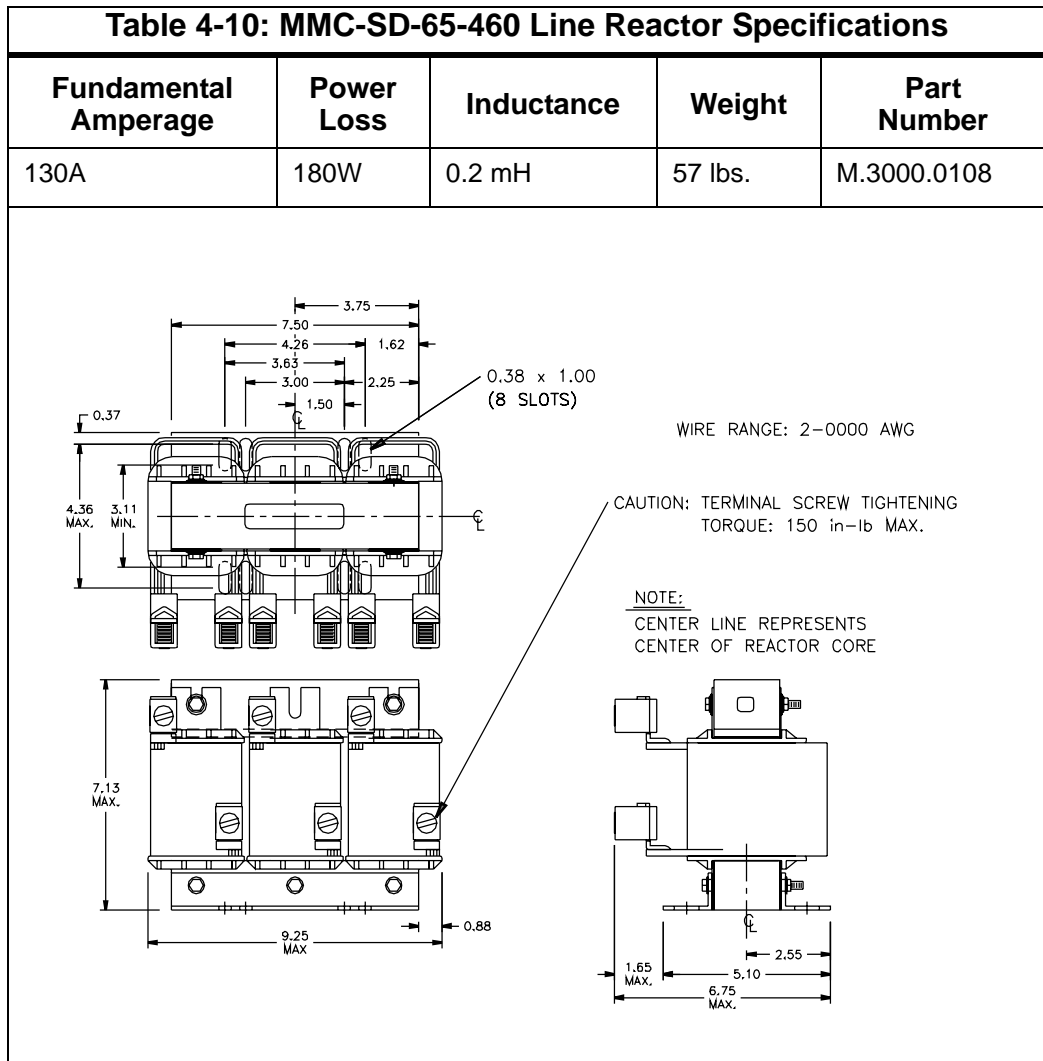


Table 4-9: MMC-SD-51-460 Line Reactor Specifications

Fundamental Amperage	Power Loss	Inductance	Weight	Part Number
100A	84W	0.3 mH	51 lbs.	M.3000.0107





4.4 Isolation Transformers

The MMC Smart Drive does not require the use of isolation transformers. However, a transformer may be required to match the voltage requirements of the controller to the available service. To size a transformer for the main AC power inputs, the power output (KVA) of each axis must be known. This can be derived by calculating the horsepower for each axis and converting that horsepower into units of watts. If power is being supplied to more than one motor and a drive, simply add the kW ratings together from each calculation to get a system kW total.

For an autotransformer, ensure that the phase to neutral/ground voltages do not exceed the input voltage ratings of the drive.

If you are using the Motions Solutions Sizing Software, the average speed and average torque data has already been calculated and can be used in the equation. If you are not sure of the exact speed and torque in your application, record the speed/torque curve for your drive/motor combination and use the resulting values as a worst case continuous speed and torque.

Calculations are multiplied by a factor to compensate for the power and loss elements within a power system. A factor of 2.0 is used with a single phase system and a factor of 1.5 is used with a three phase system. This factor should minimize the effects of the secondary line voltage sagging in the transformer during peak current periods.

The speed/torque curve information for 230V motors is based upon a drive input voltage of 230V AC. For a 115V AC input voltage, the maximum speed can be reduced up to one half.

Example 230V Formula:

$$KVA = \frac{Speed(RPM) \cdot Torque(lb - in)}{63,025} \cdot \frac{0.746 \cdot KVA}{HP} \cdot 2.0$$

Example 460V Formula:

$$KVA = \frac{Speed(RPM) \cdot Torque(lb - in)}{63,025} \cdot \frac{0.746 \cdot KVA}{HP} \cdot 1.5$$

NOTE

The 3-Phase source powering the drive has to be a center-grounded "Y" configuration. Do not exceed 304 Volts RMS from any phase to ground.

4.5 External Shunts

4.5.1 Choosing an External Shunt

Power from the motor is returned to the MMC Smart Drive during motor deceleration. Excessive power may have to be dissipated from the MMC Smart drive when large inertia loads are present. External shunts should be used to avoid excessive bus over voltage faults.

Kollmorgen recommends you use the Motion Solutions Sizing Software to determine the need for and type of external shunt. However, you may perform the following calculations to choose the external shunt for your application.

1. Obtain the Peak Generating Power for the drive in watts (W).
2. Perform the following calculation:

$$W \times T = \text{Watts/sec or Joules}$$

where:

W is watts from Step 1 above,

T is decel time required by the application

3. Obtain the Absorption Energy in Joules for the drive from the Specifications section of the drive manual.
4. Determine the Peak Shunt Power from the drive that would be delivered to the shunt resistor for your application:

- (Number calculated in Step 2 above) - (Absorption Energy from the drive Specifications table in either Chapter 5 or 6)
= Watt-seconds
 - (Watt-seconds computed in 5a. above) ÷ (Decel Time for the application) =
Peak Shunt Power in Watts
5. Determine the Continuous Shunt Power that would be delivered to the shunt resistor for this application:
- Duty Cycle of Peak or Peak x Decel Time) ÷ (Total Cycle Time) = Continuous Shunt Power in Watts
6. Choose an external shunt from [Table 4-11](#).

4.5.2 External Shunt Resistor Kits

Table 4-11: Shunt Resistors		
For Drive^a	Shunt Resistor Module	Part Number
MMC-SD-0.5-230 MMC-SD-1.0-230 MMC-SD-2.0-230	100Ω, 300W, 600V, Dynamic	M.1015.7046
MMC-SD-1.3-460 MMC-SD-2.4-460	145Ω, 450W Cont. Power, 5.4kW Peak Power, 820 V, 240 sec. Time Constant, 121 mm x 93 mm x 605 mm	M.1302.7048
MMC-SD-4.0-460	95Ω, 700W Cont. Power, 8kW Peak Power, 820 V, 250 sec. Time Constant, 121 mm x 93 mm x 705 mm	M.1302.7049
MMC-SD-6.0-460 MMC-SD-8.0-460	50Ω, 1400W Cont. Power, 17kW Peak Power, 850V, 250 sec. Time Constant, 130 mm x 182 mm x 710 mm	M.1302.7060
MMC-SD-12.0-460 MMC-SD-16.0-460	25 Ω, 2800W Cont. Power, 32kW Peak Power, 850V, 60 sec. Time Constant, 171 mm x 430 mm x 550 mm	M.1302.7061
MMC-SD-24.0-460 MMC-SD-30.0-460 MMC-SD-42.0-460 MMC-SD-51.0-460 MMC-SD-65.0-460	18Ω, 3900W Cont. Power, 70kW Peak Power, 850V, 70 sec. Time Constant, 180 mm x 445 mm x 490 mm	M.1302.7063

a. Drive Model pertains to Analog (no dash suffix) and digital (-D)

4.5.3 Mounting Dimensions for External Shunts

Figure 4-2: Mounting Dimensions for 230V External Shunt (P/N M.1015.7046)

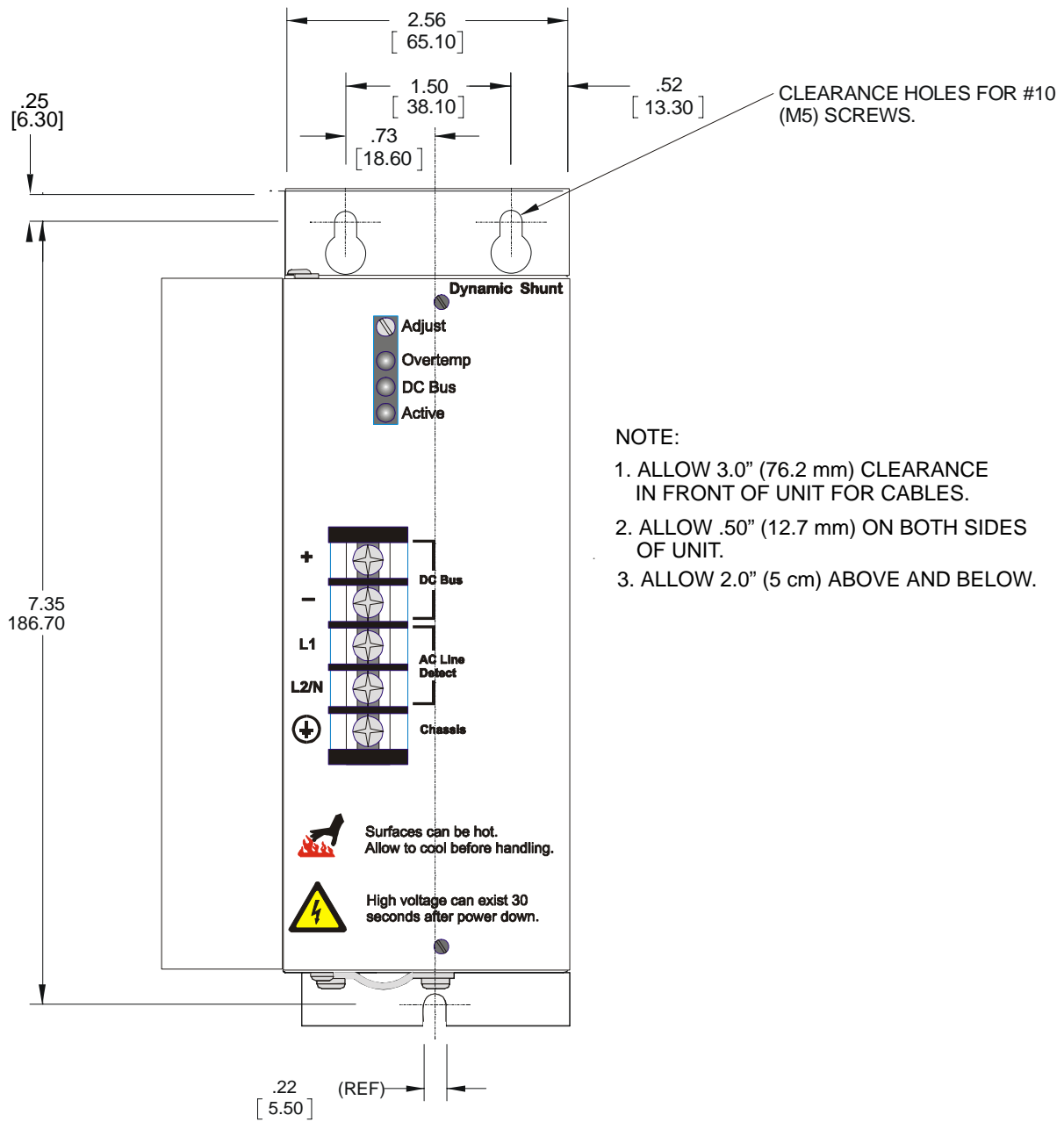


Figure 4-3: Mounting Dimensions for 460V External Shunt (P/N M.1302.7048)

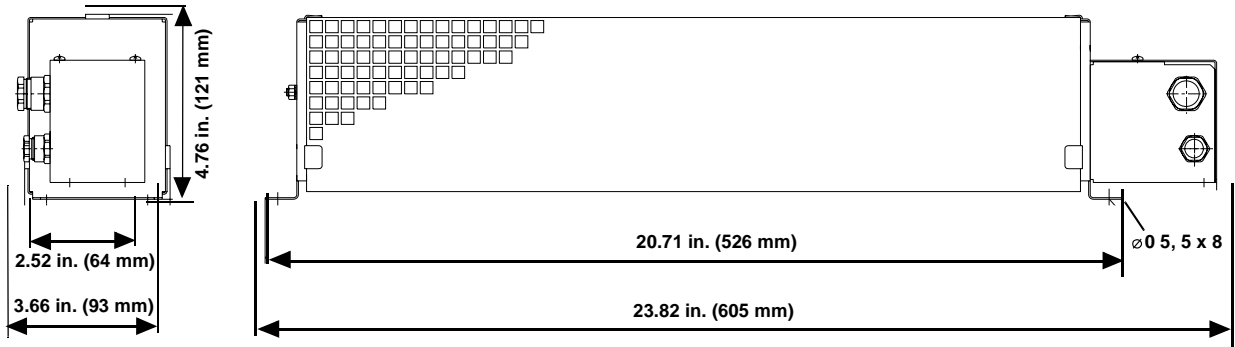


Figure 4-4: Mounting Dimensions for 460V External Shunt (P/N M.1302.7049)

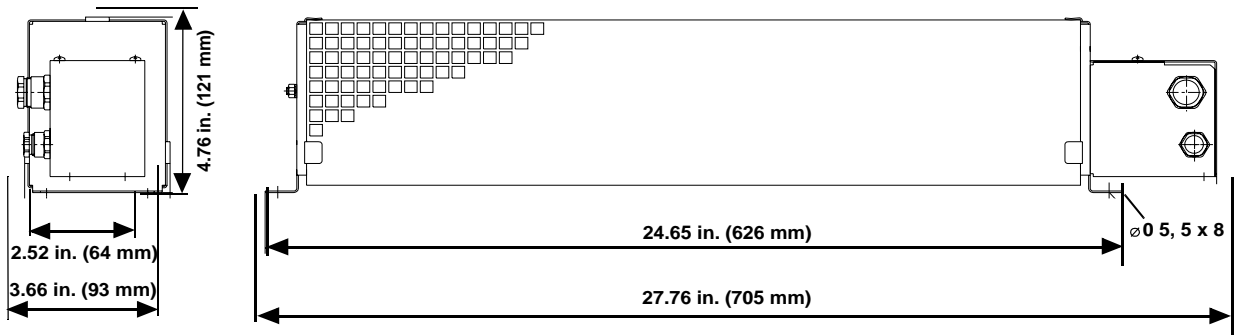


Figure 4-5: Mounting Dimensions for 460V External Shunt (P/N M.1302.7060)

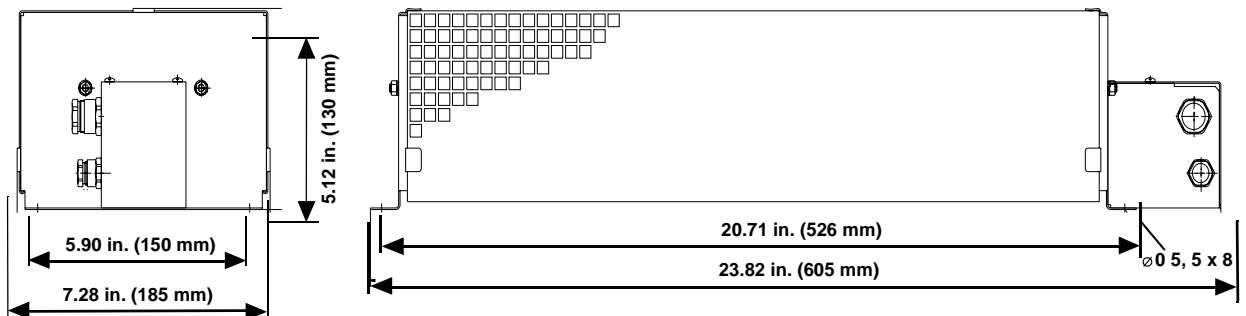


Figure 4-6: Mounting Dimensions for 460V External Shunt (P/N M.1302.7061)

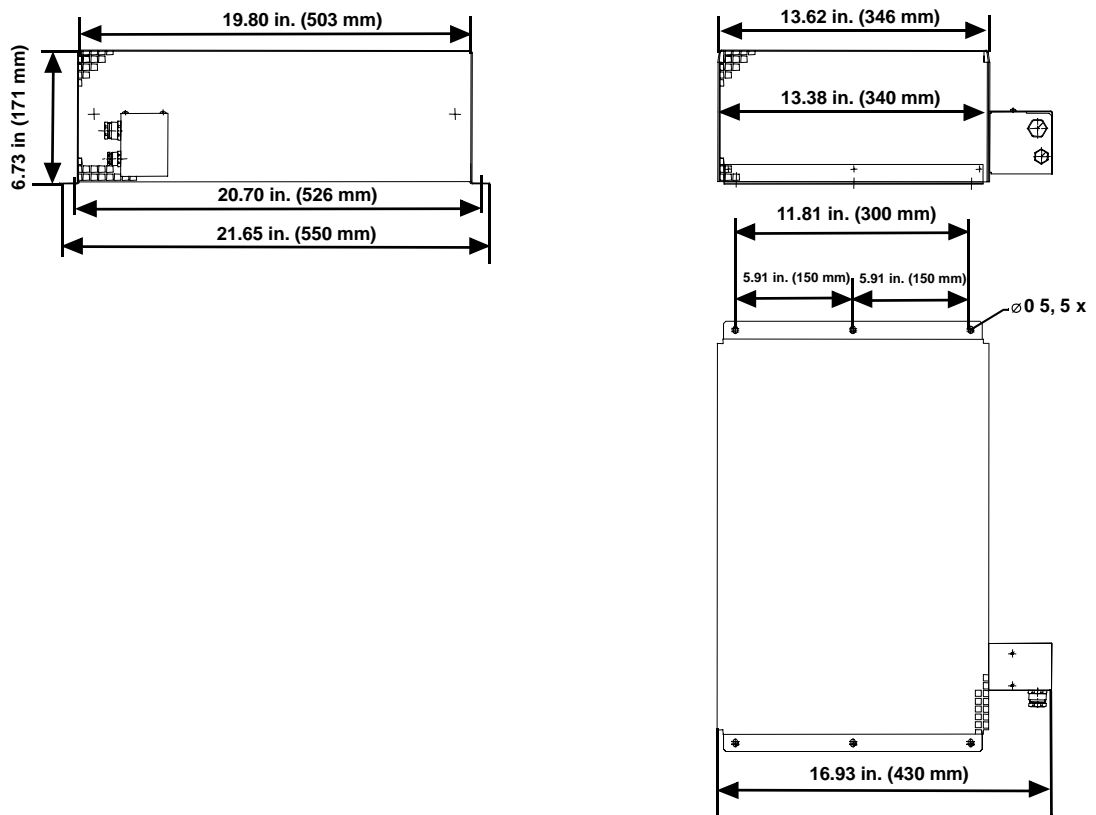
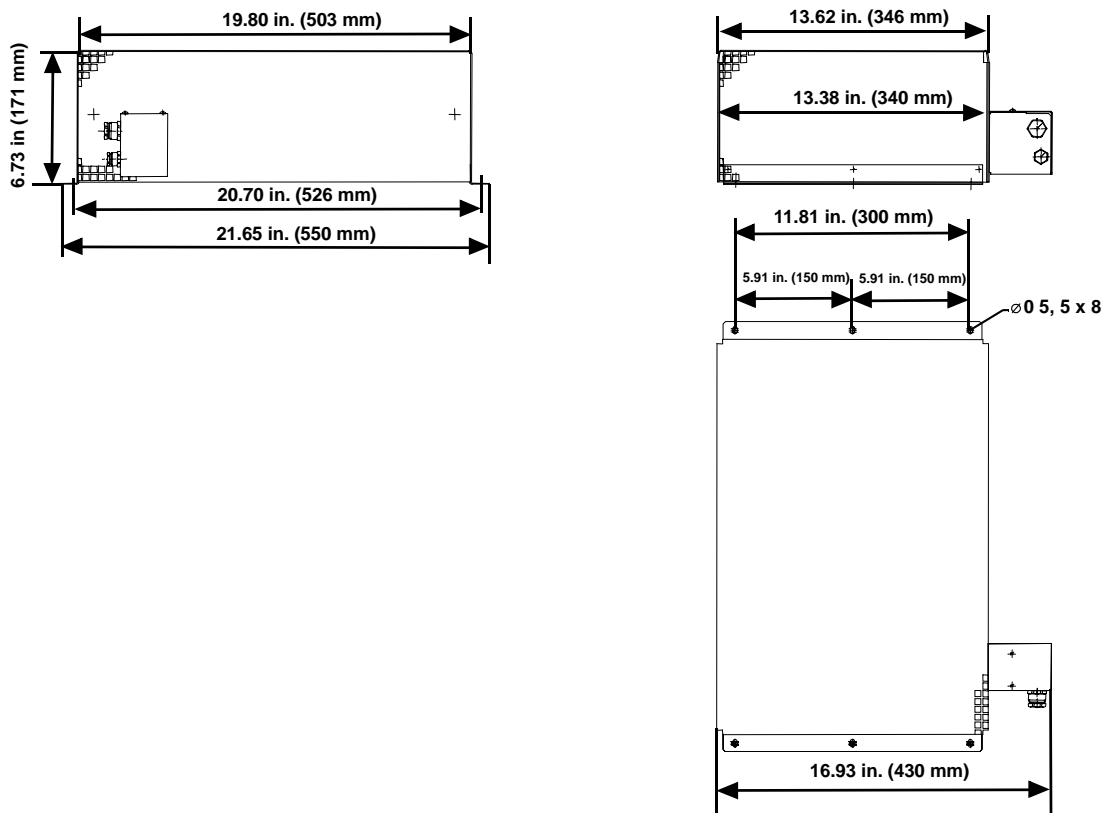


Figure 4-7: Mounting Dimensions for 460V External Shunt (P/N M.1302.7063)

4.6 Line Filters

Line Filters consist of combinations of capacitors, reactors, resistors and voltage limiters that are intended to reduce the electromagnetic influence of the environment.

4.6.1 Line Filters and CE Compliance

The direction of influence is bi-directional, i.e. there is a reaction in the units of emission of conducted disturbances, and, at the same time, an improvement in the immunity of the drive to interference that occurs in the case of lightning strikes, tripped fuses, or simple switching activities.

- The filter should be mounted to a grounded conductive surface.
- The filter must be mounted close to the drive input terminals. If the distance exceeds 2 feet (600 mm), then a shielded cable should be used to connect the drive and filter, rather than a wire.
- The wires connecting the AC source to the filter should be shielded from, or at least separated from the wires (or strap) connecting the drive to the filter. If the connections are not segregated from each other, then the EMI on the drive side of the filter can couple over to the source side of the filter, thereby reducing, or eliminating the filter effectiveness. The coupling mechanism can be radiation, or stray capacitance between the wires.

Figure 4-8: Block Diagram Simplified for 3-Phase Line Filter

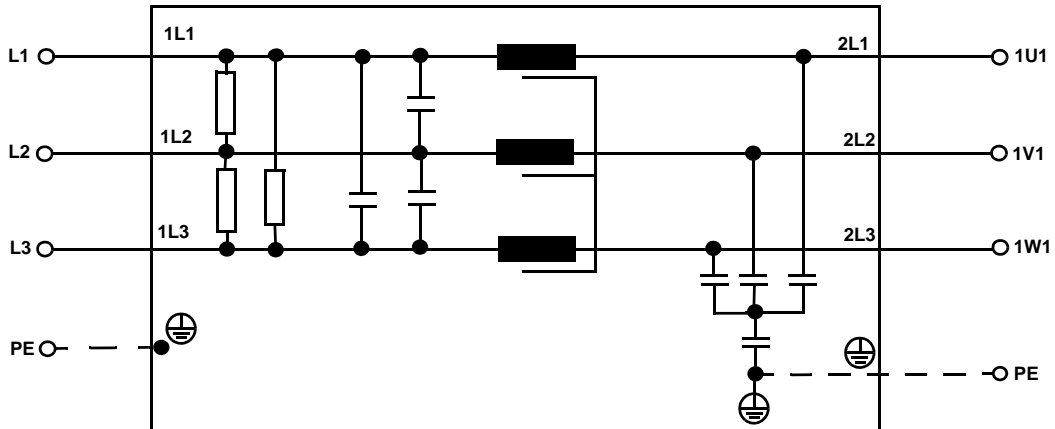
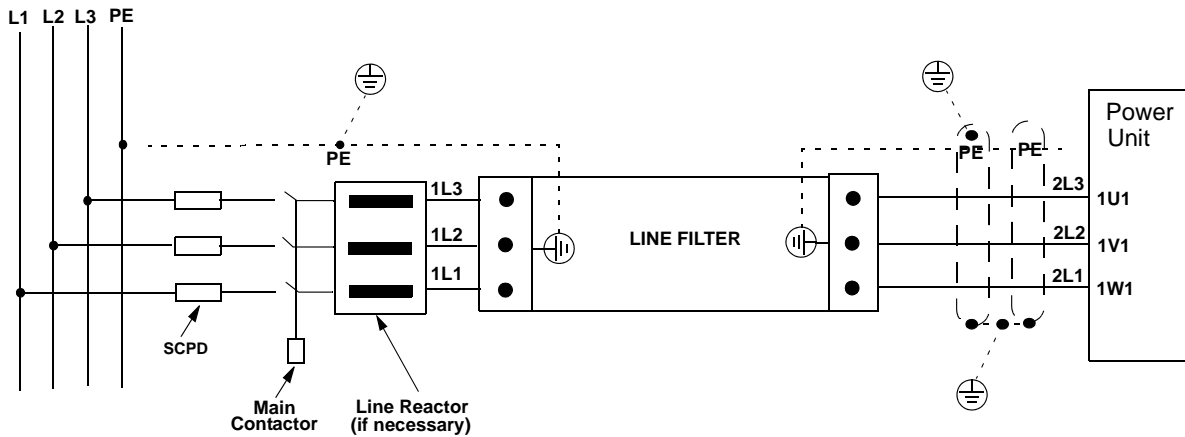



Figure 4-9: Connection Diagram for 3-Phase Line Filter



WARNING	
	<p>High leakage currents exist in AC line filters. The filters must be grounded properly before applying power. Filter capacitors retain high voltages after removal. Measure voltages to determine safe levels prior to handling the equipment. Failure to do so could result in severe bodily injury.</p>

NOTE
<p>To be able to route the interference currents at low impedance back to the interference sources, the filter, the power unit, and the contact area of the motor cable shield must have a junction with the common mounting plate over as wide a surface as possible that has good conductive properties. The best way to ensure this is to use unpainted zinc-coated mounting plates.</p>

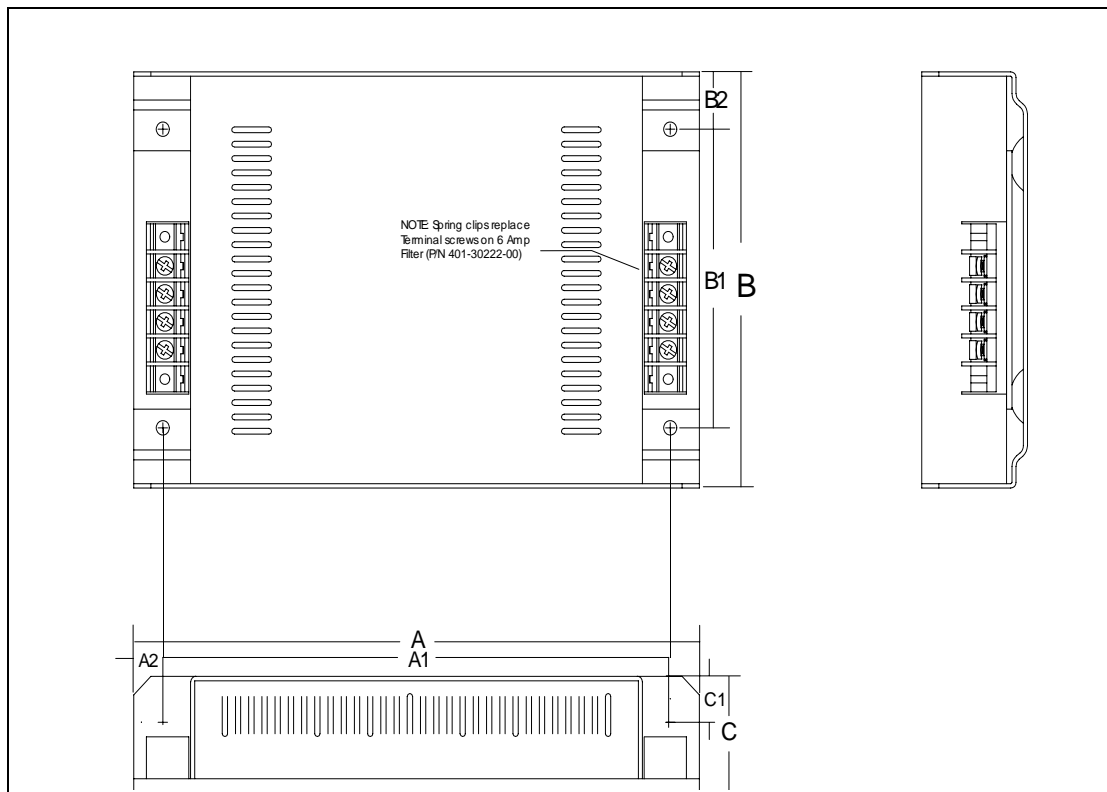
Table 4-12: Part Numbers for AC Line Filters		
Current	For Drive	Part Number
6A, 250V, 1 Phase	MMC-SD-0.5-230 MMC-SD-1.0-230	M.1015.6922
10A, 250V, 1 Phase	MMC-SD-2.0-230	M.1015.6917
7A, 480V, 3 Phase	MMC-SD-1.3-460 MMC-SD-2.4-460	M.1302.5241
16A, 480V, 3 Phase	MMC-SD-4.0-460 MMC-SD-6.0-460 MMC-SD-8.0-460	M.1302.5244
30A, 480V, 3 Phase	MMC-SD-12.0-460 MMC-SD-16.0-460	M.1302.5245
42A, 480V, 3 Phase	MMC-SD-24.0-460	M.1302.5246
56A, 480V, 3 Phase	MMC-SD-30.0-460 MMC-SD-42.0-460	M.1302.5247
75A, 480V, 3 Phase	MMC-SD-51.0-460	M.1302.5248
100A, 480V, 3 Phase	MMC-SD-65.0-460	M.3000.0109

Table 4-13: Technical Data for 230V Line Filters			
	M.1015.6922	M.1015.6917	M.1015.6918
Voltage/Freq.	250VAC @ 50/50Hz	250VAC @ 50/50Hz	250VAC @ 50/50Hz
Current	6A @ 50°C	10A @ 50°C	23A @ 50°C
Overload Current	150% 1 minute 200% 1 second	150% 1 minute 200% 1 second	150% 1 minute 200% 1 second
Temperature	-25 to 95°C	-25 to 95°C	-25 to 95°C
Leakage Current	5mA @ 240V, 50 Hz	46mA @ 240V, 50 Hz	200mA @ 250V, 50Hz
Electric Strength	2500VAC/1 minute	2500VAC/1 minute	2500VAC/1 minute
Power Loss	3.5W (Full Load)	2.7W (Full Load)	10W (Full Load)
Terminals	2mm sq. spring clamp	M4 screw cross/ sq. 2x 2.5mm	M4 screw cross/ sq. 2x 2.5mm
Weight	0.3Kg (0.66 Lb.)	0.95Kg (2.0 Lb)	1.6Kg (2.5 Lb)
Back Mounting ^a	4 x M4	4 x M4	4 x M4
Side Mounting ^a	2 x M5	2 x M6	2 x M6

a. Line filters are manufactured to millimeter dimensions (inches are approximate conversions).

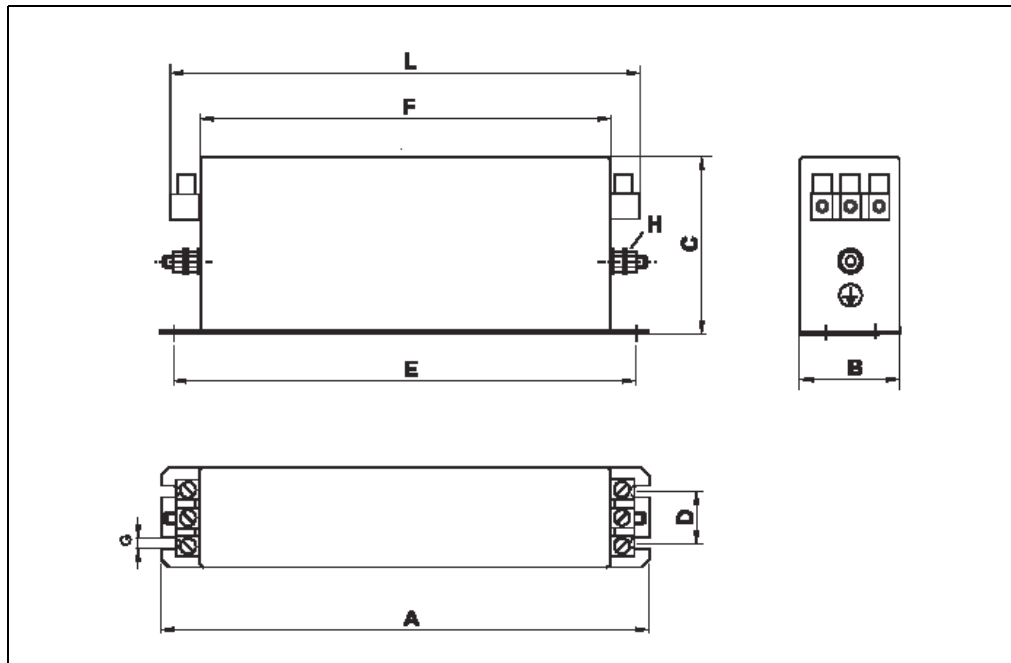
Table 4-14: Technical Data for 460V Line Filters							
Item	Part Number						
	M.1302.5241	M.1302.5244	M.1302.5245	M.1302.5246	M.1302.5247	M.1302.5248	M.3000.0109
Maximum Supply Voltage	3 x 480VAC, 50/60Hz						
Rated current (at 40°C)	7A	16A	30A	42A	56A	75A	100A
Peak current	1.5 x I _N for < 1 min. per hour at T _B = 40°						
Test Voltage Phase/Phase Phase/Ground	2.1 kVDC for 2 sec. at 25°C 2.7 kVDC for 2 sec. at 25°C						
Maximum Connection Cross-section	4mm ²	4mm ²	10mm ²	10mm ²	4mm ²	25mm ²	50mm ²
Operational Environmental Temperature Range T _B	-25°C ... +55°C Reduction of rated current from 40°C onwards by 1.4% / °C						
Power Loss (typical)	4W	8W	12W	15W	18W	24W	24W
Site Altitude	Below 2000 m above sea level (higher altitudes on request)						
Storage Temperature Range	-25°C ... +85°C						
Type of Protection	IP20						
Weight	0.6kg	1.0kg	1.3kg	1.6kg	1.9kg	2.6kg	4.0kg

4.6.2 Dimensions for 230V Line Filters



MEASUREMENT	SINGLE PHASE 6A M.1015.6922		SINGLE PHASE 10A M.1015.6917		SINGLE PHASE 23A M.1015.6918	
	mm	in	mm	in	mm	in
A	170	6.7	214	8.4	214	8.4
A1	152	6.0	192	7.6	192	7.6
A2	9	0.4	11	0.4	11	0.4
B	92	3.6	145	5.7	204	8.0
B1	55	2.2	104	4.1	164	6.6
B2	18	0.7	20	0.8	20	0.8
C	25	1.0	40	1.6	47	1.8
C1	10	0.4	16	0.6	19	0.8

4.6.3 Dimensions for 460V Line Filters

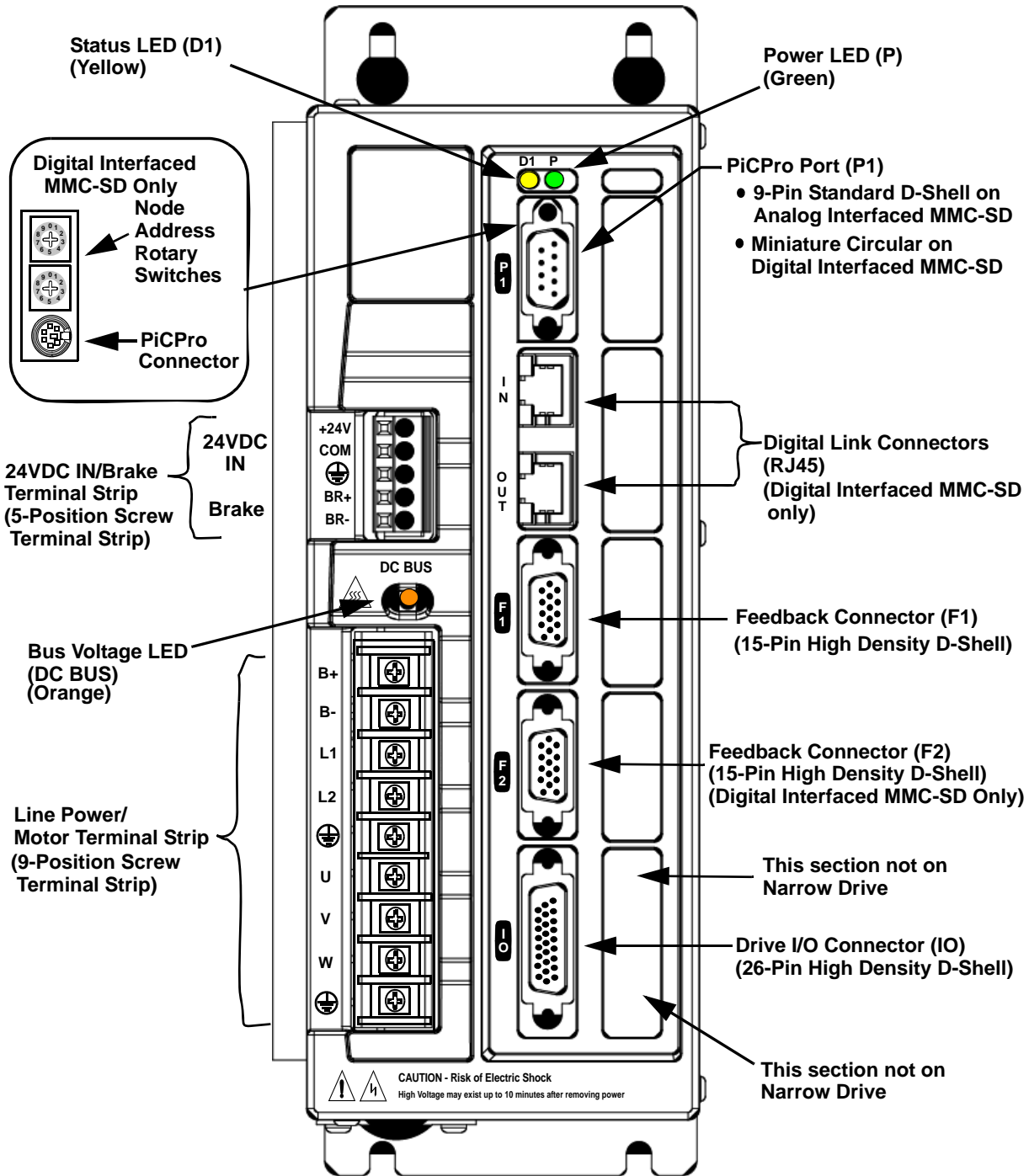


Part Number	A	B	C	D	E	F	L	G	H
M.1302.5241	190	40	70	20	180	160	185	5.4	M5
M.1302.5244	250	50	70	25	235	220	245		
M.1302.5245	270	50	85	30	255	240	265		
M.1302.5246	310	50	85	30	295	280	305	6.5	M6
M.1302.5247	250	85	90	60	235	220	258		
M.1302.5248	270	80	135	60	255	240	278		
M.3000.0190	270	90	150	65	255	240	326	6.5	M10

5 230V Single Phase MMC Smart Drive

The 230V MMC Smart Drive is available in both analog and digital interfaced versions, with power ratings of .5kW, 1kW, and 2kW. This section describes these drives in detail.

Figure 5-1: Front Panel, 230V Single Phase (500W, 1kW, 2 kW)

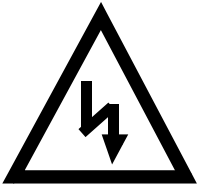


5.1 Control Section Connectors, Switches, LEDs

This section describes the connectors, switches, and LEDs located on the Control Section (right portion) of the drive.

NOTE
The functionality and descriptions for the switches, connectors, and LEDs on the control section of the 460V MMC Smart Drives are the same as those on the 230V MMC Smart Drive.

5.1.1 LEDs

LED	Color	Description
P	Green	Power LED. Indicates when illuminated that power is being supplied to the 24V input terminal strip.
D1	Yellow	Status LED. Drive status and fault information.
DC BUS 	Orange	Bus Voltage LED. Indicates when illuminated that the DC bus is at a hazardous voltage (not available on 460V Smart Drives). DANGER DC bus capacitors may retain hazardous voltages for up to ten minutes after input power has been removed. Always use a voltmeter to ensure that the DC bus voltage is below 50VDC before servicing the drive. Failure to observe this precaution could result in severe bodily injury or loss of life.

5.1.2 PiCPro Port (Digital Interfaced Drives)

This section details the PiCPro Port connector on the Digital Interfaced Drives (-D and -DN). For information on the PiCPro Port connector on Analog Interfaced Drives, see [section 5.1.3 on page 65](#).

The 6-pin circular DIN PiCPro Port connector (labeled “P1” on the front of the Drive) provides serial communication for the PiCPro programming interface.

- Pin descriptions for are provided in [Table 5-2](#)
- Pin assignments are provided in [Table 5-3](#)
- The available PiCPro Port to PC cable is described in [Table 5-4](#)

USB ADAPTER
<p>A USB-to-RS232 Adapter is available (P/N M.3000.0879) that allows you to connect the PiCPro Port on the Control to a USB connector on your PC. One side of the Adapter contains a 6in cable that connects to your PC. The other side of the Adapter contains a male DB9 connector that allows connection to the Control using a PiCPro Cable M.1302.8250 (not provided, described in Table 5-7 on page 68).</p>

Table 5-2: PiCPro Port Pin Descriptions

Function	Notes	Pin
Receive Data	RS232-level signal that receives serial data from the connected PC running PiCPro.	1
Transmit Data	RS232-level signal that transmits serial data to the connected PC running PiCPro.	2
Signal Ground	Provides the return path for signals	3 and 5
Shield Ground	Provides a path for shield current through the chassis to an external single point ground.	Connector Shell

Table 5-3: PiCPro Port Pin Assignments

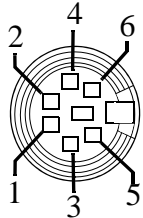
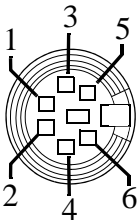
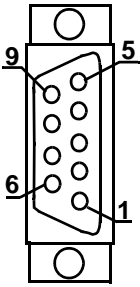
Pin	Signal	In/Out	Connector Pinout
1	RS232 Receive Data	In	<p style="text-align: center;">6-pin Female Miniature Circular DIN</p> 
2	RS232 Transmit Data	Out	
3	Signal Ground	In/Out	
4	NC	N/A	
5	Signal Ground	In/Out	
6	NC	N/A	
Connector Shield	Shield	In	

Table 5-4: PiCPr0 Port to PC Cable

Part Number: M.1302.8284 Length: 4 M (13 ft) Cable type: 24 AWG, shielded, twisted pair, 4 conductor.				
6-Pin male Miniature Circular DIN (to PiCPro Port, face view)		9-Pin female D-sub (to PC COM Port, face view)		
				
Pin	Signal	Pin	Signal	Notes
1	RS232 Receive Data	3	RS232 Transmit Data	Twisted Pair
2	RS232 Transmit Data	2	RS232 Receive Data	
5	Signal Ground	5	Signal Ground	
Shell	Drain	Shell	Drain	

5.1.3 PiCPro Port (Analog Drives)

This section details the PiCPro Port connector on the Analog Interfaced Drives (not -D or -DN). For information on the PiCPro Port connector on Digital Interfaced Drives, see [section 5.1.2 on page 63](#).

The 9-pin male D-sub PiCPro Port connector (labeled “P1” on the front of the Drive) provides serial communication for the PiCPro programming interface.

- Pin descriptions for are provided in [Table 5-5](#)
- Pin assignments are provided in [Table 5-6](#)
- The available PiCPro Port to PC cable is described in [Table 5-7](#)

USB ADAPTER
<p>A USB-to-RS232 Adapter is available (P/N M.3000.0879) that allows you to connect the PiCPro Port on the Control to a USB connector on your PC. One side of the Adapter contains a 6in cable that connects to your PC. The other side of the Adapter contains a male DB9 connector that allows connection to the Control using a PiCPro Cable M.1302.8250 (not provided, described in Table 5-7 on page 68).</p>

Function	Notes	Pin
Receive Data	RS232-level signal that receives serial data from the connected PC running PiCPro.	2
Transmit Data	RS232-level signal that transmits serial data to the connected PC running PiCPro.	3
Signal Ground	Provides the return path for signals	5
Data Terminal Ready	Always high (tied to +12V through 1K resistor)	4
Request-to-send	Always high (tied to +12V through 1K resistor)	7
Shield Ground	Provides a path for shield current through the chassis to an external single point ground.	Connector Shell

Table 5-6: PiCPro Port Pin Assignments			
Pin	Signal	In/Out	Connector Pinout
1	NC	N/A	<p>9-pin male D-sub</p>
2	RS232 Receive Data	In	
3	RS232 Transmit Data	Out	
4	Data Terminal Ready	Out	
5	Signal Ground	In/Out	
6	NC	N/A	
7	Request-to-send	Out	
8	NC	N/A	
9	NC	N/A	
Connector Shield	Drain	In	

Table 5-7: PiCPr0 Port to PC Cable

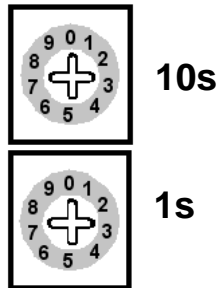
Part Number: M.1302.8250 Length: 4 M (13 ft) Cable type: 24 AWG, shielded, twisted pair, 4 conductor.				
9-Pin female D-sub (to PiCPro Port, face view)		9-Pin female D-sub (to PC COM Port, face view)		
Pin	Signal	Pin	Signal	Notes
2	Receive Data	3	Transmit Data	Twisted Pair
3	Transmit Data	2	Receive Data	
5	Signal Ground	5	Signal Ground	
Shell	Drain	Shell	Drain	

5.1.4 Node Address Rotary Switch (Digital Interfaced MMC-SD Only)

Two rotary switches are used to set the drive address. Rotate the switch to the desired address.

Addresses can be set to any number from 1 through 64. The top switch represents values of base ten. The bottom switch represents values of base 1.

As an example, rotating the switch to a setting of 2 on the top switch equals the value of 20 (2 x 10). Rotating the switch on the bottom switch to a setting of 5 equals the value of 5. The actual address setting is 25 (20 + 5).



5.1.5 Digital Link Ports (Digital Interfaced MMC-SD Only)

The two 8-pin RJ-45 Digital Link Port connectors (labeled “IN” and “OUT” on the front of the Drive) provide communications between Drives and between a Drive and a Standalone MMC Digital Control. Also provided are two green “Link” lights located between the RJ-45 connectors. The left light will be on if there is a Drive or Digital Control connected to the “IN” port, and the right light will be on if there is a Drive connected to the “OUT” port.

A “straight-through” shielded cable must be used when connecting the Drive to either the Standalone MMC Digital Control or another Drive. Connect the cable from the Drive’s “OUT” port to the next Drive’s “IN” port, or from the Standalone MMC Digital Control’s “B” port to the Drive’s “IN” port. Refer to the Standalone MMC Hardware Manual for Control information.

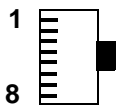
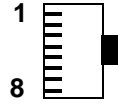
- Pin descriptions for are provided in [Table 5-8](#)
- Pin assignments are provided in [Table 5-9](#)
- The available Digital Link Port to Digital Drive cables are described in [Table 5-10](#)

Table 5-8: Digital Link Port Pin Description

Digital Link Connector (IN/OUT) Signals		Pin	
Function	Notes	“In” Connector	“Out” Connector
Receive Data +	Receives data from connected drives.	1	3
Receive Data -	Receives data from connected drives.	2	6
Transmit Data +	Transmits data to connected drives.	3	1
Transmit Data -	Transmits data to connected drives.	6	2
Protective Ground	Provides a path for the ground signal to an external single point ground.	Connector Shell	Connector Shell

Table 5-9: Digital Link Port Pin Assignments

Pin	Label	In/Out	Connector Pinout
IN Connector			
1	Receive +	In	<p>RJ-45 Connectors</p>
2	Receive -	In	
3	Transmit +	Out	
4	Not Used	N/A	
5	Not Used	N/A	
6	Transmit -	Out	
7	Not Used	N/A	
8	Not Used	N/A	
Connector Shield	Provides a path for the ground signal to an external single point ground.	In	
OUT Connector			
1	Transmit +	Out	
2	Transmit -	Out	
3	Receive +	In	
4	Not Used	N/A	
5	Not Used	N/A	
6	Receive -	In	
7	Not Used	N/A	
8	Not Used	N/A	
Connector Shield	Provides a path for the ground signal to an external single point ground.	In	

Table 5-10: Digital Link Port “IN” to “OUT” Cables				
Part Numbers: .3 M (1.0 ft): M.1302.8285 .6 M (2.0 ft): M.1302.8286 1 M (3.3 ft): M.1302.8287 2 M (6.6 ft): M.1302.8288 3 M (9.8 ft): M.1302.8289 5 M (16.4 ft): M.1302.8300 10 M (32.8 ft): M.1302.8301 15 M (49.2 ft): M.1302.8302 30 M (98.4 ft): M.1302.8303 Cable type: 28 AWG, shielded, twisted pair, 8 conductor.				
8-Pin RJ-45 Plug (to Digital Link Port “OUT”, face view) 		8-Pin RJ-45 Plug (to Digital Drive “IN”, face view) 		
Pin	Signal	Pin	Signal	Notes
1	Transmit Data +	1	Receive Data +	Twisted
2	Transmit Data -	2	Receive Data -	Pair
3	Receive Data +	3	Transmit Data +	Twisted
6	Receive Data -	6	Transmit Data -	Pair
4	None	4	None	Twisted
5	None	5	None	Pair
7	None	7	None	Twisted
8	None	8	None	Pair
Shell	Drain	Shell	Drain	

5.1.6 Feedback Connectors (F1 & F2)

The two 15-pin female Feedback connectors (labeled “F1” and “F2” on the front of the Drive) provide the interface between two feedback devices. A detailed description of the capabilities and limitations of connected devices can be found in [section 5.1.6.1 on page 76](#).

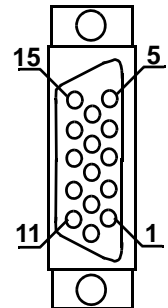
- Pin descriptions for the F1 connector are provided in [Table 5-11](#)
- Pin assignments for the F1 connector are provided in [Table 5-12](#)
- Pin descriptions for the F2 connector are provided in [Table 5-13](#)
- Pin assignments for the F2 connector are provided in [Table 5-14](#)
- The available Flying Lead cable is described in [Table 5-16](#).
- Available Breakout Boxes and Cables are described in [Table 5-17](#).
- Breakout Box dimensions are shown in [Figure 5-2](#)
- Breakout Board dimensions are shown in [Figure 5-3](#)
- Feedback Port to Motor Cables are described in [section 5.1.6.2 on page 80](#)

Table 5-11: Pin Description for Feedback Connector (F1)

F1 Feedback Signals			
Signal Type	Signal Name	Notes	Pin
Incremental Encoder Inputs	A1, A1/, B1, B1/, I1, I1/	Differential A quad B encoder signals.	1, 2, 3, 4, 5, 10
Sinewave Encoder Inputs	Sin, Sin/, Cos, Cos/	Sinewave Encoder signals	1, 2, 3, 4
Sinewave Encoder Data Channel In/Out	RS-485 Data +, RS-485 Data -, RS-485 Clock+, RS-485 Clock-	RS-485 signals for connecting the Sinewave Encoder Data Channel to the drive	5, 10, 12, 13
Motor Commutation Hall Sensor Inputs	Commutation Track S1, S2, S3	Hall device input signals that are used to initialize the commutation angle. They consist of a 74HC14 input with 10 μ s filter and 1 K pull up to +5V. Shared with F2.	12, 13, 8
Sinewave Encoder Commutation Inputs	Commutation Sin+, Commutation Sin-	Sinewave signals that are used to initialize the motor commutation angle when a Heidenhein Sincoder is used as the motor feedback device.	12, 13
Resolver Inputs	Sin+, Sin-, Cos+, Cos-	Resolver rotor feedback signals used when optional Resolver Interface Board is installed.	1, 2, 3, 4
Resolver Outputs	Carrier+, Carrier-	Resolver rotor excitation signals used when optional Resolver Interface Board is installed.	5, 10
Temperature Input	Temperature	Thermostat (normally- closed) or Thermistor (Phillips KTY84-130 PTC or equivalent recommended) input for detecting over temperature conditions within the motor.	11
+5V Encoder Power Outputs	+5V Source	Regulated +5VDC for powering the attached encoder (F1 pin 14 + F2 pin 14 = 500ma max).	14
+9V Encoder Power Outputs	+9V Source	Regulated +9VDC for powering the attached encoder (F1 pin 7 + F2 pin 7 = 150ma max).	7
Sinewave Encoder Reference Mark Input	Ref Mark, Ref Mark/	Reference Mark input used with some Sinewave Encoders used to indicate motor position within one revolution.	5, 10
Signal and Power Common	Common	Return path for feedback signals and power supplies (+5V and +9V).	6

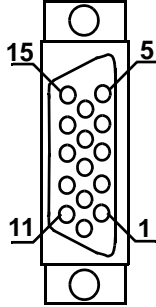
Table 5-12: Pin Assignments for Feedback Connector (F1)

Encoder/Resolver Pin Assignments for Motor Feedback 15 Pin Connector (F1) 230V Single Phase (500W, 1kW, 2kW)							
Pin	Feedback Device					In/ Out	Connector Pinout
	Sinewave Encoder						
	Digital Incremental Encoder	Stegmann Hiperface	Endat ^a BiSS ^{a,b} SSI ^{a,c}	Heidenhain Sincoder	Resolver ^d		
1	A1	Cos		Cos+	In	15-pin Female HD D-Sub	
2	A1/	Cos/		Cos-			
3	B1	Sine		Sin+			
4	B1/	Sine/		Sin-			
5	I1	RS-485 Data+		Ref Mark	Carrier+		Note ^e
6	Common						In/Out
7	N/U	+9V Source	N/U	N/U	N/U		Out
8	Commutation Track S3	N/U	N/U	N/U	N/U		In
9	N/U			Commuta- tion Cos+	N/U		
10	I1/	RS-485 Data-		Ref Mark/	Carrier-		Note ^e
11	Temperature						In
12	Commutation Track S1	N/U	RS-485 Clock+	Commuta- tion Sin+	N/U		In ^f
13	Commutation Track S2	N/U	RS-485 Clock-	Commuta- tion Sin-	N/U		
14	+5V Source	N/U	+5V Source		N/U		Out
15	N/U			Commuta- tion Cos-	N/U		In
Shell	Shield					N/A	



- a. Available on Digital Interfaced MMC-SD only
- b. Not on all Part Numbers. See [Chapter 12](#) for details
- c. For future use
- d. Requires installation of optional resolver board.
- e. Pins 5 and 10 are In/Out for Stegmann Hiperface and Endat; Inputs for Digital Incremental, SSI, BiSS, Heidenhain Sincoder; and Outputs for Resolver
- f. Pins 12 and 13 are Outputs for ENDAT, SSI, and BiSS

Table 5-13: Pin Description for Feedback Connector (F2) (Digital Interfaced MMC-SD Only)		
F2 Feedback Signals		
Signal Type	Notes	Pins
Incremental Encoder Input	Differential A quad B encoder signals.	1,2, 3, 4, 5, 10
Motor Commutation Hall Sensor Inputs	Hall-device input signals that are used to initialize the motor commutation angle. They consist of a 74HC14 input with a 10 μ s filter and a 1K pull-up to +5V. Shared with F1.	8, 12, 13
Temperature Input	Thermostat (normally-closed) or Thermistor (Phillips KTY84-130 PTC or equivalent recommended) input for detecting over temperature conditions within the motor. If a thermostat is used, connect one side to 0V, and the other side to the Temperature Input (pin 11).	11
+5V Encoder Power Outputs	Regulated +5VDC for powering the attached encoder (F1 pin 14 + F2 pin 14 = 500ma max).	14
+9V Encoder Power Outputs	Regulated +9VDC for powering the attached encoder (F1 pin 7 + F2 pin 7 = 150ma max).	7
Signal and Power Common	Return path for feedback signals and power supplies (+5V and 9 V).	6

Table 5-14: Pin Assignments for Feedback Connector (F2) (Digital Interfaced MMC-SD Only)			
Pin Assignments F2 Feedback 15 Pin Connector 230V Single Phase (500W, 1kW, 2kW)			
Pin	Label	In/Out	Connector Pinout
1	A2	In	15-pin Female HD D-Sub 
2	A2/	In	
3	B2	In	
4	B2/	In	
5	I2	In	
6	Common	In/Out	
7	+9V	Out	
8	S3	In	
9	Do Not Connect	N/A	
10	I2/	In	
11	Temperature	In	
12	S1	In	
13	S2	In	
14	+5V	Out	
15	Do Not Connect	N/A	
Shell	Shield	In	

5.1.6.1 Feedback Connectors (F1 and F2) Details

The F1 and F2 Feedback connectors support a variety of devices and functions. This section helps clarify the capabilities and limitations of connected devices.

- All signals (other than the encoder inputs) are bussed internally between the two feedback connectors F1 and F2. The bussed signals include motor commutation inputs, temperature input, +5V power, +9V power, and encoder power outputs.
- F1 can interface with incremental encoders, sinewave encoders, and resolvers (using the optional resolver interface module). These signals are conditioned and routed to the Drive I/O connector.
- F2 can be designated (in PiCPro) as the motor feedback connector but only if F1 is not (either one or the other must be designated as such).
- F2 can interface with only incremental type encoders.
- The hall sensor inputs on F1 and F2 are connected together, allowing either F1 or F2 to accept the hall sensor signal, but NOT both. Only one feedback may be connected to motor hall sensor inputs.
- Refer to [Table 5-15](#) for more information regarding the valid combinations of feedback on the F1 and F2 connectors.

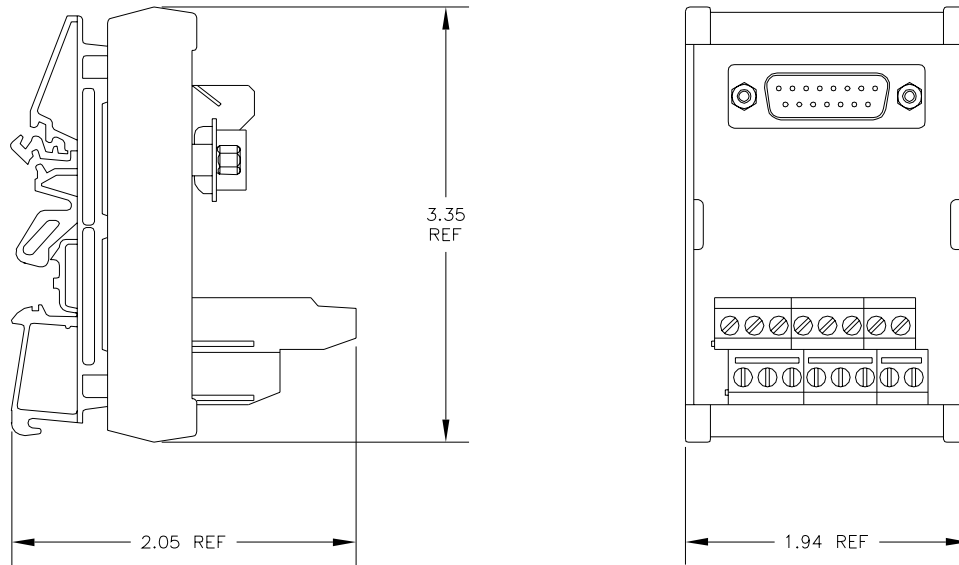
Table 5-15: Supported Feedback Combinations	
Drive Feedback Configuration 1 and 4 (in PiCPro Drive Setup)	
F1 (Motor mounted feedback device for motor control)	F2 (Externally mounted feedback device for position feedback)
<ul style="list-style-type: none"> • Incremental Encoder with commutation halls • Resolver • Sincoder with commutation halls • Endat2.1 (single or multi-turn) • Stegmann Hiperface (single or multi-turn) • BiSS (single or multi-turn) 	<ul style="list-style-type: none"> • Incremental Encoder without commutation halls
Drive Feedback Configuration 2 and 3 (in PiCPro Drive Setup)	
F1 (Externally mounted feedback device for position feedback)	F2 (Motor mounted feedback device for motor control)
<ul style="list-style-type: none"> • Sincoder without commutation halls • Resolver 	<ul style="list-style-type: none"> • Incremental Encoder with commutation halls

Table 5-16: Feedback Port (F1 and F2) to Flying Lead Cable			
Part Number: M.1016.2519 Length: 3 M (10 ft) Cable type: 28 AWG, shielded, twisted pair, 16 conductor.			
15-Pin HD male D-sub (to F1/F2 Port, face view)			
Pin	Signal	Color	Notes
1	A1, Cos, Cos+	Blue	Twisted Pair
2	A1/, Cos/, Cos-	Blue/White	
3	B1, Sine, Sin+	Black	Twisted Pair
4	B1/, Sine/, Sin-	Black/White	
5	I1, RS-485 Data+, Ref Mark, Carrier+	Red	Twisted Pair
10	I1/, RS-485 Data-, Ref Mark/, Carrier-	Red/White	
8	Commutation Track S3	Green	Twisted Pair
9	Commutation Cos+	Green/White	
6	Common	Yellow	Twisted Pair
7	+9V Source	Yellow/White	
11	Temperature	Orange	Twisted Pair
11	Temperature	Orange/White	
12	Commutation Track S1, RS-485 Clock+, Commutation Sin+	Brown	Twisted Pair
13	Commutation Track S2, RS-485 Clock-, Commutation Sin-	Brown/White	
14	+5V source,	Violet	Twisted Pair
15	Commutation Cos-	Violet/White	
Shell	Drain	N/A	

Table 5-17: Feedback Ports (F1 and F2) Breakout Box and Cables		
Description	Length	Part Number
MMC-SD F1/F2 Port Breakout Board ^a	N/A	M.1302.6970
MMC-SD F1/F2 Port Breakout Box ^b	N/A	M.1302.6972
MMC-SD F1/F2 Port to Breakout Box Cable	1 M (3.3 ft)	M.1302.6976
	3 M (9.8 ft)	M.1302.6977
	9 M (29.5 ft)	M.1302.6979
	15 M (49.2 ft)	M.1302.6980
MMC-SD F1/F2 Port Breakout Box and Cable Kits. These kits include an M.1302.6972 Breakout Box and an inter-connect cable of the indicated length	1 M (3.3 ft)	M.1302.7005
	3 M (9.8 ft)	M.1302.7006
	9 M (29.5 ft)	M.1302.7007
	15 M (49.2 ft)	M.1302.7008

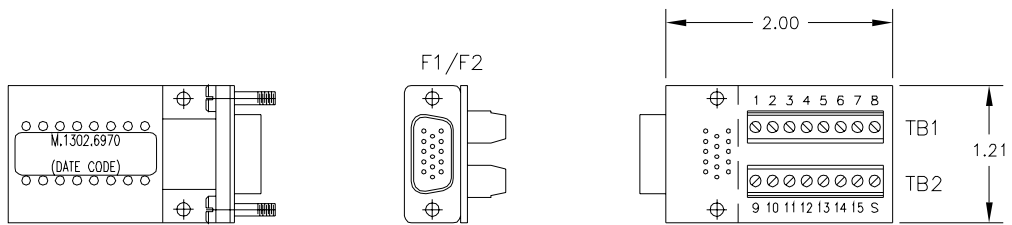
- a. The Breakout Board (see [Figure 5-3 on page 79](#)) is mounted directly to the F1 and/or F2 connector, and provides screw terminals wire termination.
- b. The Breakout Box (see [Figure 5-2 on page 79](#)) is DIN-rail mounted, and provides screw terminal wire termination. Use one of the cables listed in the table to connect between the F1 and/or F2 connector and the Breakout Box.

Figure 5-2: Feedback Port (F1 and F2) Breakout Box Dimensions



D15 SUB/P
PART NO. M.1302.6972

Figure 5-3: Feedback Port (F1 and F2) Breakout Board Dimensions



DANAHER MOTION PART NUMBER	DANAHER MOTION SHORT DESCRIPTION
M.1302.6970	BKOUT BD,F1/F2,MMC-SD DR MT

5.1.6.2 Feedback Port (F1/F2) to Motor Cables

Several cables are available that allow easy connection between the Feedback Port (F1/F2) and various Kollmorgen motors. These cables are detailed in the following tables. For information on Non-Flex versus Hi-Flex cables, refer to [section 8.1 on page 171](#).

Table 5-18: F1/F2 Endat/BiSS to AKM/DDR Motor Cables		
For Connection Diagram, see Table 5-24: on page -83.		
Length	Non-Flex P/N	Hi-Flex P/N
1 M (3.3 ft)	M.1302.8605	M.1302.8613
3 M (9.8 ft)	M.1302.8437	M.1302.8438
6 M (19.7 ft)	M.1302.8606	M.1302.8614
9 M (29.5 ft)	M.1302.8607	M.1302.8615
15 M (49.2 ft)	M.1302.8608	M.1302.8616
30 M (98.4 ft)	M.1302.8609	M.1302.8617

Table 5-19: F1/F2 Resolver to AKM/DDR Motor Cables		
For Connection Diagram, see Table 5-25: on page -84.		
Length	Non-Flex P/N	Hi-Flex P/N
1 M (3.3 ft)	M.1302.8618	M.1302.8630
3 M (9.8 ft)	M.1302.8439	M.1302.8450
6 M (19.7 ft)	M.1302.8619	M.1302.8631
9 M (29.5 ft)	M.1302.8620	M.1302.8632
15 M (49.2 ft)	M.1302.8621	M.1302.8633
30 M (98.4 ft)	M.1302.8622	M.1302.8634

Table 5-20: F1/F2 Encoder to AKM/DDR Motor Cables		
For Connection Diagram, see Table 5-26: on page -85.		
Length	Non-Flex P/N	Hi-Flex P/N
1 M (3.3 ft)	M.1302.8590	M.1302.8600
3 M (9.8 ft)	M.1302.8447	M.1302.8435
6 M (19.7 ft)	M.1302.8591	M.1302.8601
9 M (29.5 ft)	M.1302.8542	M.1302.8602
15 M (49.2 ft)	M.1302.8594	M.1302.8603
30 M (98.4 ft)	M.1302.8595	M.1302.8604

Table 5-21: F1/F2 Encoder to LSM/MSM Motor Cables		
For Connection Diagram, see Table 5-27: on page -86.		
Length	Non-Flex P/N	Hi-Flex P/N
1 M (3.3 ft)	M.1302.8590	M.1302.8600
3 M (9.8 ft)	M.1302.8447	M.1302.8435
6 M (19.7 ft)	M.1302.8591	M.1302.8601
9 M (29.5 ft)	M.1302.8542	M.1302.8602
15 M (49.2 ft)	M.1302.8594	M.1302.8603
30 M (98.4 ft)	M.1302.8595	M.1302.8604

Table 5-22: F1/F2 Encoder to FSM Motor Cables		
For Connection Diagram, see Table 5-28: on page -87.		
Length	Non-Flex P/N	Hi-Flex P/N
1 M (3.3 ft)	M.1301.3927	N/A
3 M (9.8 ft)	M.1301.4011	N/A
9 M (29.5 ft)	M.1301.4012	N/A
15 M (49.2 ft)	M.1301.4013	N/A
30 M (98.4 ft)	M.1301.4014	N/A

Table 5-23: F1/F2 Encoder to YSM Motor Cables		
For Connection Diagram, see Table 5-29: on page -88.		
Length	Non-Flex P/N	Hi-Flex P/N
1 M (3.3 ft)	M.1301.3983	N/A
2 M (6.6 ft)	M.1302.7675	N/A
3 M (9.8 ft)	M.1301.3984	N/A
9 M (29.5 ft)	M.1301.3985	N/A
15 M (49.2 ft)	M.1301.3986	N/A
30 M (98.4 ft)	M.1301.3987	N/A

Table 5-24: Feedback Port (F1/F2) ENDAT/BiSS to AKM/DDR Motor Cable

For Part Numbers, see Table 5-18: on page -80.

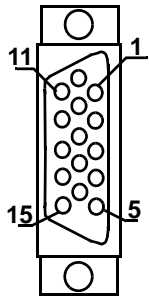
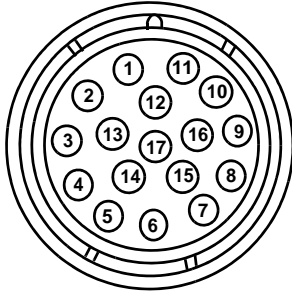

Wire Color	Pin Number	Signal Type	Pin Number	Jumper Connections	Signal Type
<p>Twisted Pair 7 pair 28 AWG 1 pair 16 AWG 1 pair 22 AWG</p> <p>15-Pin HD male D-sub Connector to MMC Smart Drive</p>  <p>Connector to Motor</p> 					
Wire Color	Pin Number	Signal Type	Pin Number	Jumper Connections	Signal Type
Yellow	1	COS	9		B+
White/Yellow	2	COS/	1		B-
Blue	3	SIN	11		A+
White/Blue	4	SIN/	3		A-
Black	5	DATA+	5		DATA
White/Black	10	DATA-	13		DATA/
Violet	12	CLOCK+	8		CLOCK
White/Violet	13	CLOCK-	15		CLOCK/
Red	N/U	N/A	12		UnSENSE VCC
White/Red	N/U	N/A	10		UnSENSE COM
Green	11	TEMPERATUR	7		THERMAL
White/Green	N/U	N/A	14		THERMAL
Orange	N/U	N/A	N/U		N/A
White/Orange	N/U	N/A	N/U		N/A
Brown	7	9 VDC	N/U		N/A
White/Brown	N/U	N/A	N/U		N/A
Gray	14	+5 VDC	4		5VDC
White/Gray	6	COM	2	GMD	
N/C	9	N/A	6	N/C	
N/C	15	N/A	16	N/C	
N/C	8	N/A	17	N/C	

Table 5-25: Feedback Port (F1/F2) Resolver AKM/DDR Motor

For Part Numbers, see [Table 5-19: on page -80.](#)

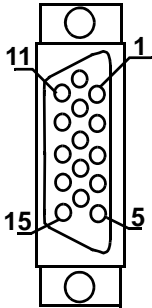
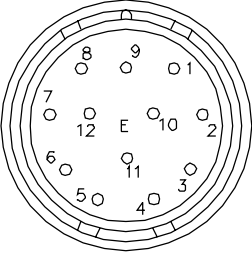
Twisted Pair 4 pair 24 AWG	D-sub 15-Pin HD Male Connector to MMC Smart Drive		Connector to Motor		
					
Wire Color	Pin Number	Signal Type	Pin Number	Jumper Connections	Signal Type
Black	1	COS+	7		COS+
White/Black	2	COS-	3		COS-
Red	3	SIN+	8		SIN+
White/Red	4	SIN-	4		SIN-
Green	5	REF+	9		REF+
White/Green	10	REF-	5		REF-
Orange	11	TEMP+	2		TEMP+
White/Orange	6	COM	6		TEMP-
N/C	7	9 VDC	9		9 VDC
N/C	8	N/A	N/U		N/A
N/C	9	+5 VDC	10	+5 VDC	
N/C	12	COM	1	N/C	
N/C	13	N/A	10	N/C	
N/C	14	N/A	11	N/C	
N/C	15	N/A	12	N/C	

Table 5-26: Feedback Port (F1/F2) Encoder to AKM/DDR Motor

For Part Numbers, see [Table 5-20: on page -81](#).

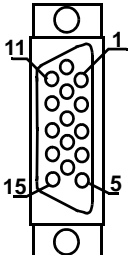
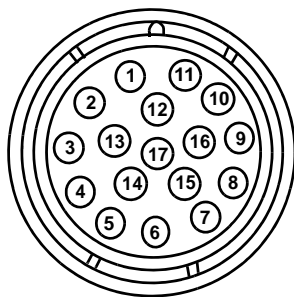
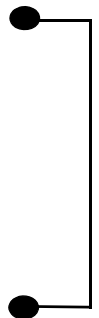
Twisted Pair 8 pair 28 AWG 1 pair 16 AWG		D-sub 15-Pin HD Male Connector to MMC Smart Drive		Connector to Motor	
					
Wire Color	Pin Number	Signal Type	Pin Number	Jumper Connections	Signal Type
Yellow	1	A	3		A
White/Yellow	2	A/	4		A/
Blue	3	B	1		B
White/Blue	4	B/	2		B/
Black	5	I	5		I
White/Black	10	I/	6		I/
Violet	12	S1	15		S1
White/Violet	13	S2	16		S2
Red	8	S3	17		S3
White/Red	N/U	N/A	N/U		N/A
Green	11	TEMPERATURE	8		TEMPERATURE+
White/Green	N/U	N/A	9		TEMPERATURE-
Orange	N/U	N/A	N/U		N/A
White/Orange	N/U	N/A	N/U		N/A
Brown	7	9 VDC	11		N/A
White/Brown	N/U	N/A	N/U	N/A	
Gray	14	+5 VDC	10	+5 VDC	
White/Gray	6	COM	7	COM	
N/C	9	N/A	12	N/C	
N/C	15	N/A	13	N/C	
			14	N/C	

Table 5-27: Feedback Port (F1/F2) Encoder to LSM or MSM Motors

For Part Numbers, see [Table 5-21: on page -81](#).

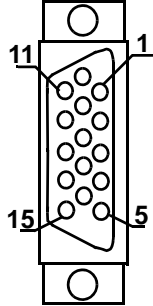
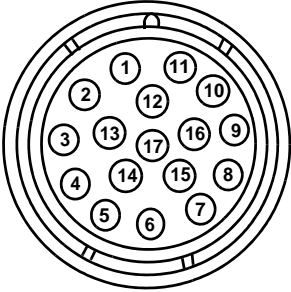
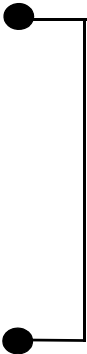
Wire Color	Pin Number	Signal Type	Pin Number	Jumper Connections	Signal Type
<div style="display: flex; justify-content: space-around;"> <div style="text-align: center;"> <p>D-sub 15-Pin HD Male Connector to MMC Smart Drive</p>  </div> <div style="text-align: center;"> <p>Connector to Motor</p>  </div> </div>					
Twisted Pair 8 pair 28 AWG 1 pair 16 AWG					
Yellow	1	A	1		A
White/Yellow	2	A/	2		A/
Blue	3	B	3		B
White/Blue	4	B/	4		B/
Black	5	I	5		I
White/Black	10	I/	6		I/
Violet	12	S1	15		S1
White/Violet	13	S2	16		S2
Red	8	S3	17		S3
White/Red	N/U	N/A	N/U		N/A
Green	11	TEMPERATURE	13		TEMPERATURE+
White/Green	N/U	N/A	14		TEMPERATURE-
Orange	N/U	N/A	N/U		N/A
White/Orange	N/U	N/A	N/U		N/A
Brown	7	9 VDC	9		9 VDC
White/Brown	N/U	N/A	N/U		N/A
Gray	14	+5 VDC	10		+5 VDC
White/Gray	6	COM	11	COM	
N/C	9	N/A	7	N/C	
N/C	15	N/A	8	N/C	
			12	N/C	

Table 5-28: Feedback Port (F1/F2) Encoder to FSM Motors

For Part Numbers, see [Table 5-22: on page -81.](#)

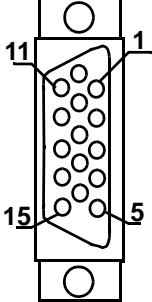
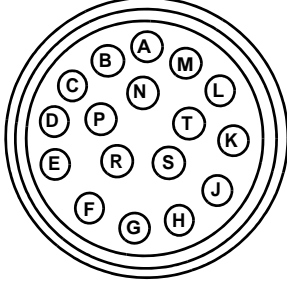

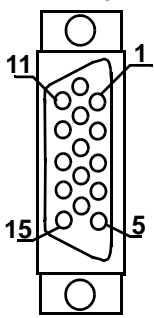
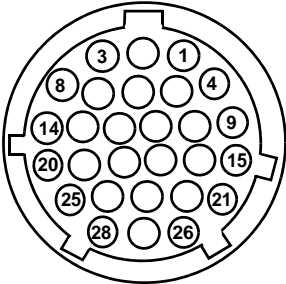
Twisted Pair, 28 AWG 16 AWG	D-sub 15-Pin HD Male Connector to MMC Smart Drive		Connector to Motor		
					
Wire Color	Pin Number	Signal Type	Pin Number	Jumper Connections	Signal Type
Black	1	A	A		A
White/Black	2	A/	B		A/
Red	3	B	C		B
White/Red	4	B/	D		B/
Green	5	I	E		I
White/Green	10	I/	F		I/
Gray	14	+5V	J		+5VDC
White/Gray	6	COM	K		+5VDC
			L		COM
			M		COM
Blue	13	S2	S		TEMPERATURE-
			N		S2
			T		S1
Brown	8	S3	P		S3
			11		TEMPERATURE
White/Violet	7	N/C	N/U	N/A	
	9	N/C	N/U	N/A	
White/Violet	15	N/C	G	N/C	
	N/U	N/A	H	N/C	

Table 5-29: Feedback Port (F1/F2) Encoder to YSM Motors

For Part Numbers, see [Table 5-23: on page -82.](#)

Twisted Pair, 28 AWG 16 AWG	D-sub 15-Pin HD Male Connector to MMC Smart Drive		Connector to Motor		
					
Wire Color	Pin Number	Signal Type	Pin Number	Jumper Connections	Signal Type
Black	1	A	9	NO JUMPERED PINS	A
White/Black	2	A/	10		A/
Red	3	B	11		B
White/Red	4	B/	12		B/
Green	5	I	13		I
White/Green	10	I/	14		I/
Gray	14	+5V	22		+5VDC
White/Gray	6	COM	23		COM
Blue	13	S2	17		S2
White/Blue	12	S1	15		S1
Brown	8	S3	19		S3
White/Brown	N/A	N/C	24		N/C
N/A	7	N/C	1		N/C
N/A	9	N/C	2		N/C
N/A	15	N/C	3		N/C
N/A	11	N/C	4-8		N/C
			16	N/C	
			18	N/C	
			20	N/C	
			21	N/C	
			25-28	N/C	

5.1.7 Drive I/O Connector (IO)

The 26-pin HD female D-sub Drive I/O Port connector (labeled “IO” on the front of the Drive) provides connection between various devices and the Drive. This port provides one Analog Command Input, two differential Fast Inputs, several General Purpose I/O points (wiring example shown in [See Figure 5-6 on page 95](#)), and buffered versions of the feedback device connected to the F1 port.

- Pin descriptions are provided in [Table 5-30](#)
- Pin assignments are provided in [Table 5-31](#)
- Available MMC Control cables are described in [Table 5-32](#)
- The available Flying Lead cable is described in [Table 5-33](#).
- Available Breakout Boxes and Cables are described in [Table 5-34](#).
- Breakout Box dimensions are shown in [Figure 5-4](#)
- Breakout Board dimensions are shown in [Figure 5-5](#)

Table 5-30: Pin Description for Drive I/O Connector (IO)

Signal Type	Notes	Pins
Analog Command Inputs (Analog Interfaced MMC-SD only)	Analog velocity or torque commands of 0 to +/- 10V. Separate scale and offset parameters are used relative to the command signal being velocity or torque	14, 15
Fast Inputs (Digital Interfaced MMC-SD only)	Used for latching encoder position.	8, 9, 11, 12
General Purpose Software Assignable Inputs	24VDC sourcing type. Default assignments: Pin 17 (GPIN1) = Drive Enable, Pin 18 (GPIN2) = Fault Reset	17, 18, 19, 20, 21, 22
Buffered F1 Encoder Output	RS485 drivers are used and the signal that is output depends on the encoder or resolver type used. See specifications in Chapter 5 of this manual. These signals are generated after the feedback from the F1 connector is filtered and processed.	1, 2, 3, 4, 5, 6
General Purpose Software Assignable Outputs	24VDC sourcing type. Default assignment: Pin 26 (GPOUT4) = Drive Ready	23, 24, 25, 26
IO24V, IO24COM	24 VDC inputs for powering GPIN and GPOUT I/O.	10, 16

Table 5-31: Pin Assignment for Drive I/O Connector (IO)

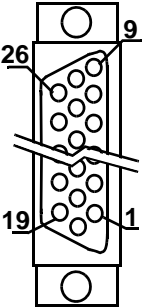
Pin	Wiring Label	PiCPro I/O Label	In/Out	Pin	Wiring Label	PiCPro I/O Label	In/Out	Connector Pinout
1	FDBK1B A		Out	14	CMD +		In	26-pin Female HD D-Sub 
2	FDBK1B A/		Out	15	CMD -		In	
3	FDBK1B B		Out	16	IO24COM		In	
4	FDBK1B B/		Out	17	GPIN1	Input1	In	
5	FDBK1B I		Out	18	GPIN2	Input2	In	
6	FDBK1B I/		Out	19	GPIN3	Input3	In	
7	Shield		Out	20	GPIN4	Input4	In	
8	GPIN7 +	Input7	In	21	GPIN5	Input5	In	
9	GPIN7 -		In	22	GPIN6	Input6	In	
10	IO24V		In	23	GPOUT1	Output1	Out	
11	GPIN8 +	Input8	In	24	GPOUT2	Output2	Out	
12	GPIN8 -		In	25	GPOUT3	Output3	Out	
13	Shield			26	GPOUT4	Output4	Out	

Table 5-32: Drive I/O Port to Analog MMC Control "An" Port Cable^a

Part Numbers:

.5 M (1.6 ft): M.1302.5990 1.5 M (4.9 ft): M.1302.5992

1 M (3.3 ft): M.1302.5991 3 M (16.4 ft): M.1302.5993

Cable type: 28 AWG (pins 10 & 16 20 AWG), shielded, twisted pair, 26 conductor.

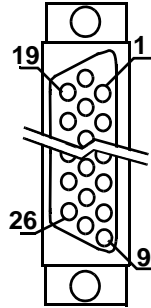
Wire Color	Pin Number	Signal Type	Pin Number	Jumper Connection	Signal Type
Black	1	A	1		A
White/Black	2	A/	2		A/
Red	3	B	3		B
White/Red	4	B/	4		B/
Green	5	I	5		I
White/Green	6	I/	10		I/
Orange	26	OUT4	6		DCIN+
White/	N/U	N/U	7		DCIN-
Blue	14	CMD+	8		DA+
White/Blue	15	CMD-	9		DA-
Yellow	17	IN1	13		DCOUT1
White/Yellow	18	IN2	14		DCOUT2
Brown	N/U	N/U	N/U		N/A
White/Brown	N/U	N/U	15		DCOSS
Violet	N/U	N/U	N/U		N/A
White/Violet	N/U	N/U	N/U		N/A
Gray	10	IO24V	11	24VDCOUT	
White/Gray	16	IOCOM	12	COM	
N/A	Shell	Shield	Shell		Shield

a. These cables are only used to interface between the Analog MMC-An control and the Analog MMC Smart Drive.

Table 5-33: Drive I/O Port to Flying Lead Cable

Part Numbers:
 1 M (3.3 ft): M.1302.7032 15 M (49.2 ft): M.1302.7036
 3 M (10 ft): M.1302.7034 30 M (98.4 ft): M.1302.7037
 9 M (29.5 ft): M.1302.7035
 Cable type: 28 AWG (pins 10 & 16 20 AWG), shielded, twisted pair, 26 conductor.

26-Pin HD male D-sub (to Drive I/O Port, face view)



Pin	Signal	Color	Notes	Pin	Signal	Color	Notes
1	A	Black	Twisted	17	GPIN1	Violet	Twisted
2	A/	Blk/Wht	Pair	18	GPIN2	Vio/Wht	Pair
3	B	Red	Twisted	19	GPIN3	Pink	Twisted
4	B/	Red/Wht	Pair	20	GPIN4	Pnk/Wht	Pair
5	I	Green	Twisted	21	GPIN5	Blk/Yel	Twisted
6	I/	Grn/Wht	Pair	22	GPIN6	Gry/Grn	Pair
7	Shield	Black	Twisted	23	GPOUT1	Grn/Red	Twisted
13	Shield	Blue	Pair	24	GPOUT2	Yel/Red	Pair
8	GPIN7 +	Blue	Twisted	25	GPOUT3	Gry/Blu	Twisted
9	GPIN7 -	Blu/Wht	Pair	26	GPOUT4	Yel/Blu	Pair
11	GPIN8 +	Yellow	Twisted	10	IO24V	Gray	Twisted
12	GPIN8 -	Yel/Wht	Pair	16	IO24C	Gry/Wht	Pair
14	CMD +	Brown	Twisted				
15	CMD -	Brn/Wht	Pair				

Description	Length	Part Number
Drive I/O Port Breakout Board ^a	N/A	M.1302.6971
Drive I/O Breakout Box ^b	N/A	M.1302.6973
Drive I/O Port to Breakout Box Cable	1 M (3.3 ft)	M.1302.6982
	3 M (9.8 ft)	M.1302.6984
	9 M (29.5 ft)	M.1302.6985
Drive I/O Port Breakout Box and Cable Kits. These kits include an M.1302.6973 Breakout Box and an interconnect cable of the indicated length.	1 M (3.3 ft)	M.1302.7009
	3 M (9.8 ft)	M.1302.7030
	9 M (29.5 ft)	M.1302.7031

- a. The Drive I/O Breakout Board (see [Figure 5-5 on page 94](#)) is mounted directly to the IO connector, and provides screw terminals wire termination.
- b. The Drive I/O Breakout Box (see [Figure 5-4 on page 94](#)) is DIN-rail mounted, and provides screw terminal wire termination. Use one of the cables listed in the table to connect between the IO connector and the Breakout Box.

Figure 5-4: Drive I/O Port Breakout Box Dimensions

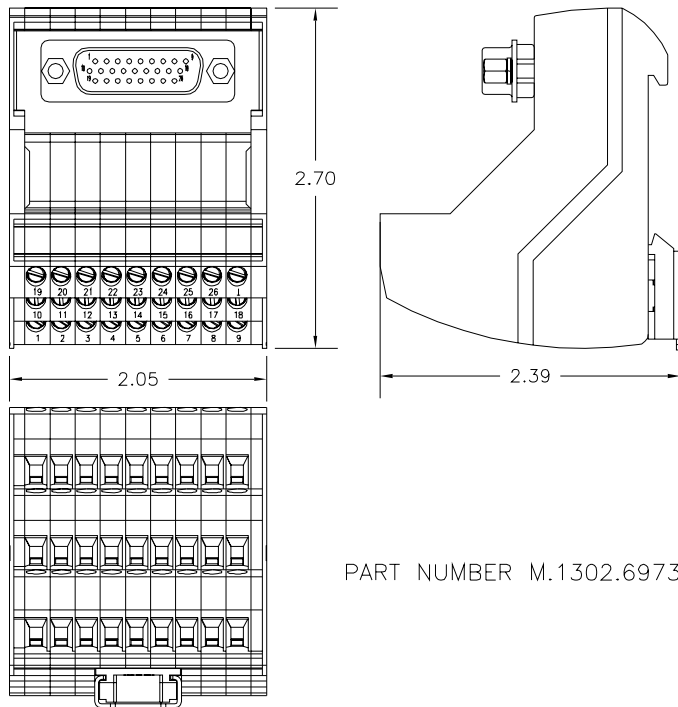


Figure 5-5: Drive I/O Port Breakout Board Dimensions

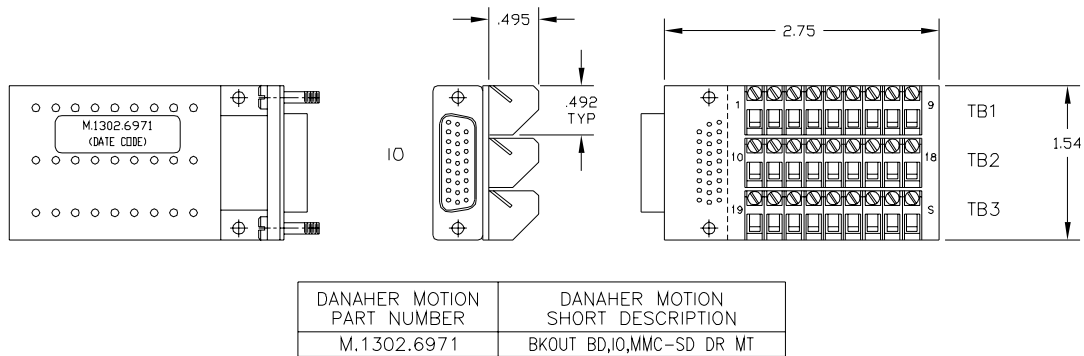
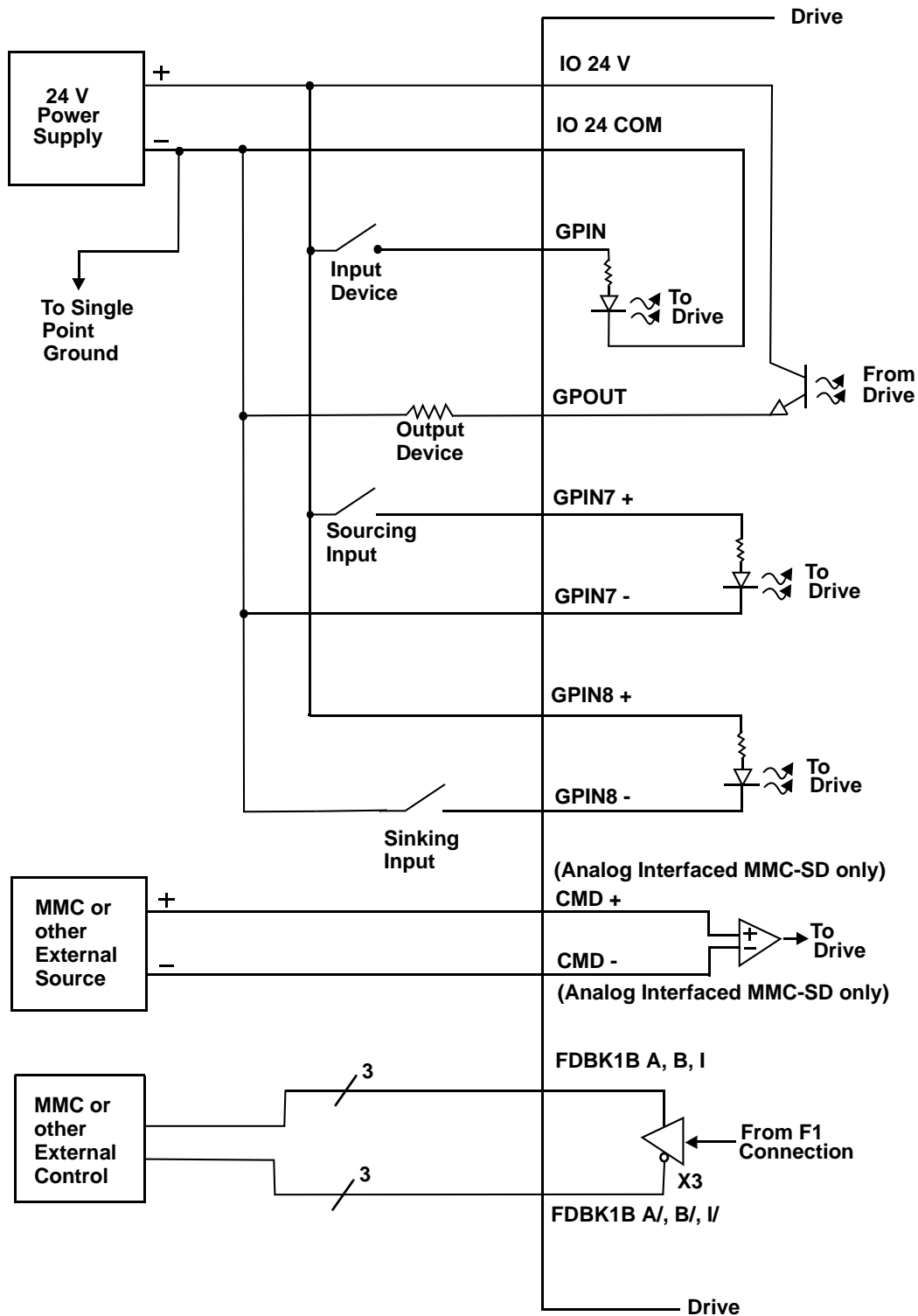


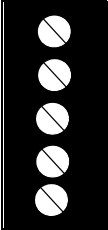

Figure 5-6: Wiring Diagram for Drive I/O Connector (IO)



5.2 Power Section Connectors

This section describes the connectors located on the Power Section (left portion) of the drive.

5.2.1 24 VDC IN/Brake Connector

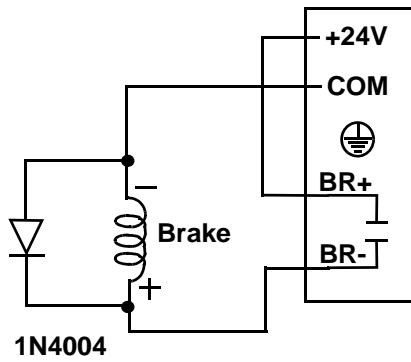
Table 5-35: Pin Assignment for 24 VDC IN/Brake Connector					
Terminal Label	Signal Type	Signal Description	PiCPro I/O Label	In/Out	Connector Pinout
+24V	Logic Power	+24V user supplied power signal terminal.	N/A	In	5-pin Pluggable Screw Terminal 
COM	Common	+24V Common	N/A	In	
	Protective Ground	Must be connected to Protective Earth Ground (SPG)	N/A	In	
BR+	Brake Relay +	Refer to Figure Figure 5-7 .	Output5 /Relay	Out	
BR-	Brake Relay -			Out	

NOTE

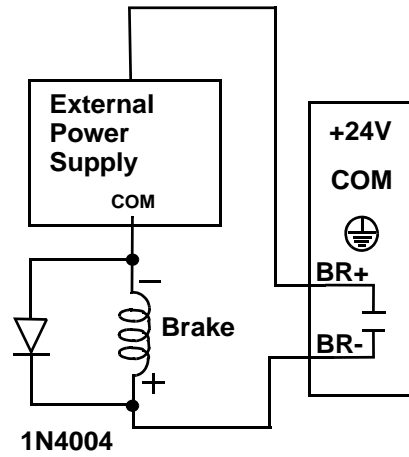
Use of a diode (as shown) or an external RC type snubber is highly recommended for use with inductive loads, especially DC inductive loads.

Figure 5-7: BR+ and BR- Wiring Examples

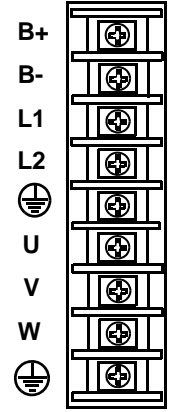


Using 24V Power Source



Using External Power Source



5.2.2 Motor Connector

Table 5-36: Pin Assignment for Motor Connector				
Terminal Label	Signal Type	Signal Description	In/Out	Pin Sequence
B+	DC Bus	Power from drive to active shunt	Out	9-pin non-plugable Screw Terminal 
B-				
L1	AC Power	100-240VAC single phase power in to drive.	In	
L2				
	Protective Ground	Must be connected to Protective Earth Ground (SPG).	In	
U	Motor Power	Power U-phase from the drive to the motor.	Out	
V		Power V-phase from the drive to the motor.	Out	
W		Power W-Phase from the drive to the motor.	Out	
	Protective Ground	Connection for motor ground.	In	

5.3 Specifications - 230V MMC Smart Drive

5.3.1 General Data for all 230V Models

General Drive Data	
Minimum wire size for input power wires	1.5mm ² (16 AWG) 75° C copper.
Maximum tightening torque for power wire terminals	1.17 Nm (10.4 in-lbs.)
Commutation	Three Phase Sinusoidal
Current Regulator	Digital PI 125 µsec. update rate
Velocity Regulator	Digital PID - 250 µsec. update rate
Environmental Data	
Operating Temperature Range	7° C to 55° C (45° F to 131° F)
Storage Temperature Range	-30° C to 70° C (-22° F to 158° F)
Humidity	5% to 95% non-condensing
Altitude	1500 m (5000 ft) Derate 3% for each 300 m above 1500m
Vibration Limits (per IEC 68-2-6) Operating/Non-operating	10-57 Hz (constant amplitude, 15 mm) 57 - 2000 Hz (acceleration 2 g)
Shock (per IEC 68-2-27) Non-operating	Four shocks per axis (15g/11 msec)
F1 and F2 Feedback Inputs	
Input receiver type	Maxim 3098 A quad B differential RS422 receiver
Encoder signals	Differential quadrature
Input threshold	±200 mV
Input termination	150Ω, provided internally
Maximum input voltage	5V peak to peak differential -10 to +13.2V common mode
Maximum input signal frequency	720 K Hz (2.88 M feedback counts per second)
+5V regulated output	500ma max between F1 and F2
+9V regulated output	150ma max between F1 and F2

General Purpose Inputs	
Configuration	<ul style="list-style-type: none"> • 8 optically isolated 24V DC inputs • Active high • 6 are current sourcing only (current flow into input) • 2 are sink or source
Guaranteed On	15 VDC
Guaranteed Off	5 VDC
Time delay on	1 ms max.
Time delay off	1 ms max.
Input voltage	Nominal 24 VDC, maximum 30 VDC
General Purpose Outputs	
Configuration	<ul style="list-style-type: none"> • 4 optically isolated 24V DC outputs • Active high • Current sourcing only (current into load) • Short circuit and overload protected
Maximum current	50mA per output
Voltage range	24VDC +15%-10%
Time delay on for resistive loads	50 µsec. max
Time delay off for resistive loads	50 µsec. max
Leakage current in off state	0.5 mA max
Command Input (Analog Interfaced MMC-SD only)	
Command Input	Analog velocity or torque, 0 to $\pm 10V$ 14 bit effective resolution

Digital Link In/Out Ports (Digital Interfaced MMC-SD only)	
"In" port	Sends and receives high speed data to and from connected MMC-SD's "Out" port.
"Out" port	Sends and receives high speed data to and from connected MMC-SD's "In" port.
Cable Type	Shielded, Straight Pinned, CAT5 or better (CAT5e, CAT6, etc.)
Maximum Cable Length	30 m (98.4 ft)

Drive I/O Connector Encoder Emulation Output	
F1 Motor Feedback Type	Input Limit Encoder Emulation Output (A quad B Differential Output)
Incremental Encoder	720 KHz 2.88 M counts/sec. The motor encoder A/B/I inputs are electrically buffered and retransmitted via the Drive I/O connector.
High Resolution Encoder	100 KHz 400 K counts/sec. The encoder SIN/COS signals are electrically squared and retransmitted as A/B. The index mark "I" is synthesized by the drive control DSP. Absolute position information is not available via the Encoder Emulation Output.
Resolver	500 RPS 2.00 M counts/sec. The field-installable resolver interface module converts the motor resolver to 1024 lines/4096 counts per revolution of A/B encoder output. The module synthesizes the index mark "I" once per revolution of the resolver. Absolute position information is not available via the Encoder Emulation Output.
Conformity	
CE Marked	Conforms to Low Voltage Directive 73/23/EEC (amended by 93/68/EEC) and EMC Directive 89/336/EEC (amended by 92/31/EEC and 93/68/EEC). Conformance is in accordance with the following standards: EN 50178 and EN61800-3
UL and C/UL Listed	E233454

5.3.2 Physical and Electrical Data for 230V Drives

	Model		
	MMC-SD-0.5-230 (-D, -DN)	MMC-SD-1.0-230 (-D, -DN)	MMC-SD-2.0-230 (-D, -DN)
Part Numbers			
Analog, standard width	M.1302.5090	M.1302.5091	M.1302.5092
Digital			
Standard width, no BiSS	M.1302.8130	M.1302.8131	M.1302.8132
Standard width, Biss	M.3000.0461	M.3000.0462	M.3000.0463
Narrow width, no BiSS	M.1302.8908	M.1302.8910	M.1302.8911
Narrow width, Biss	M.3000.0458	M.3000.0459	M.3000.0460
Physical			
Weight	4.9 lbs. (2.23 kg)	5.6 lbs. (2.55 kg)	5.7 lbs. (2.59 kg)
Electrical Specifications			
AC Input Specifications			
Nominal Input Power	1.0 kVA	2.0 kVA	4.0 kVA
Input Voltage	100-240 VAC (nominal), Single Phase, 88-265 VAC (absolute limits)		
Input Frequency	47 - 63 Hz		
Nominal Input Current	5A RMS	9A RMS	18A RMS
Maximum Inrush Current (0-Peak)	70A	70A	70A
Power Loss	22W	37W	70W
AC Output Specifications			
Continuous Output Current RMS (0-Peak)	1.8A (2.5A)	3.5A (5A)	7.1A (10A)
Continuous Output Power			
Input = 115 VAC	250W	500W	1kW
Input = 230 VAC	500W	1kW	2kW
Peak Output Current (0-Peak)	7.5A	15A	30A
Output Frequency	0-266 Hz		

DC Input Power Specifications (24VDC)		
Input Voltage Range	24 VDC +15% -10%	
Typical Input Current	375 mA	
Typical Input Wattage	9 W	
Inrush Current	1.5 A for 10 ms	
Relay Contact for Motor Mechanical Brake		
Rating (resistive load)		
Nominal switching capacity	24 VDC	
Maximum switching power	831 VA	
Maximum switching voltage	250 VAC / 100 VDC	
Maximum switching current	5 A (AC) / 2.5 A (DC)	
Energy Absorbtion Specifications		
DC Bus Capacitance (Internal)	1410 μ F	1880 μ F
Bus overvoltage threshold	420 VDC	
Joules available for energy absorption		
230V motor w/115V line input	94 joules	126 joules
230V motor w/230V line input	38 joules	51 joules

5.4

Dimensions for 230V MMC Smart Drive

This section contains dimensional information on the narrow width (-DN) Digital MMC-SD drive, the standard width (-D) Digital MMC-SD drive, and the Analog Interfaced drive (no letter suffix). Use this information to determine mounting hole locations on the drive panel.

When locating the drive on the panel, observe the clearance requirements found in [Table 3-1 on page 19](#). Mount the drive to the panel with #10 bolts and #10 star washers (to ensure proper ground connection).

Figure 5-8: 500 W Narrow Drive (-DN) - Front View

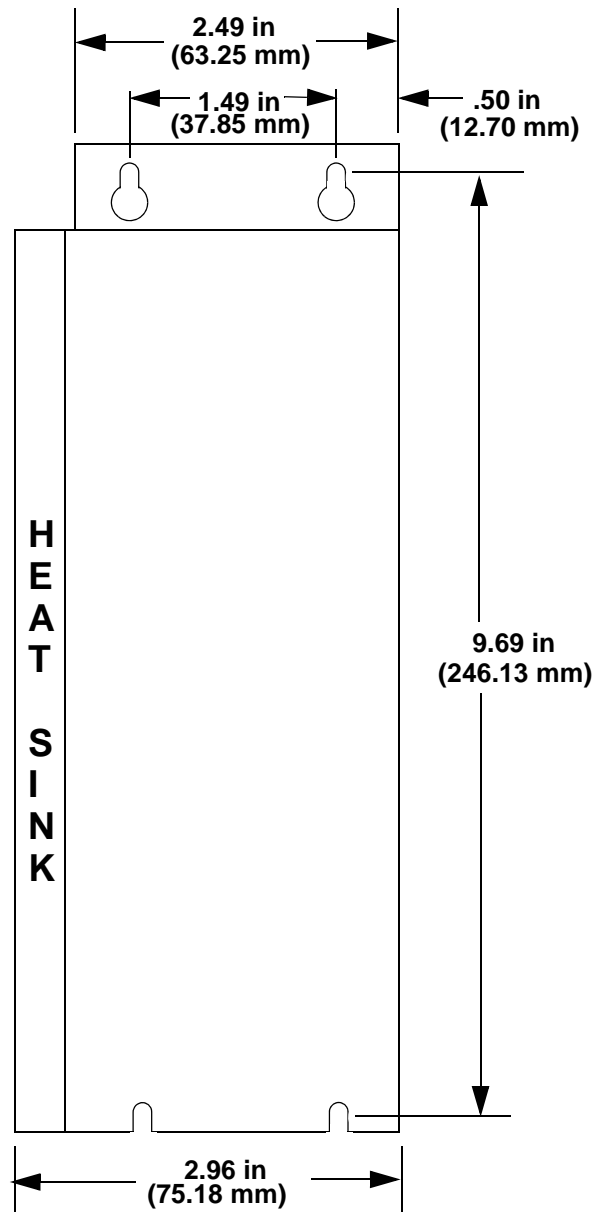


Figure 5-9: 500 W Standard Drive (non-DN) - Front

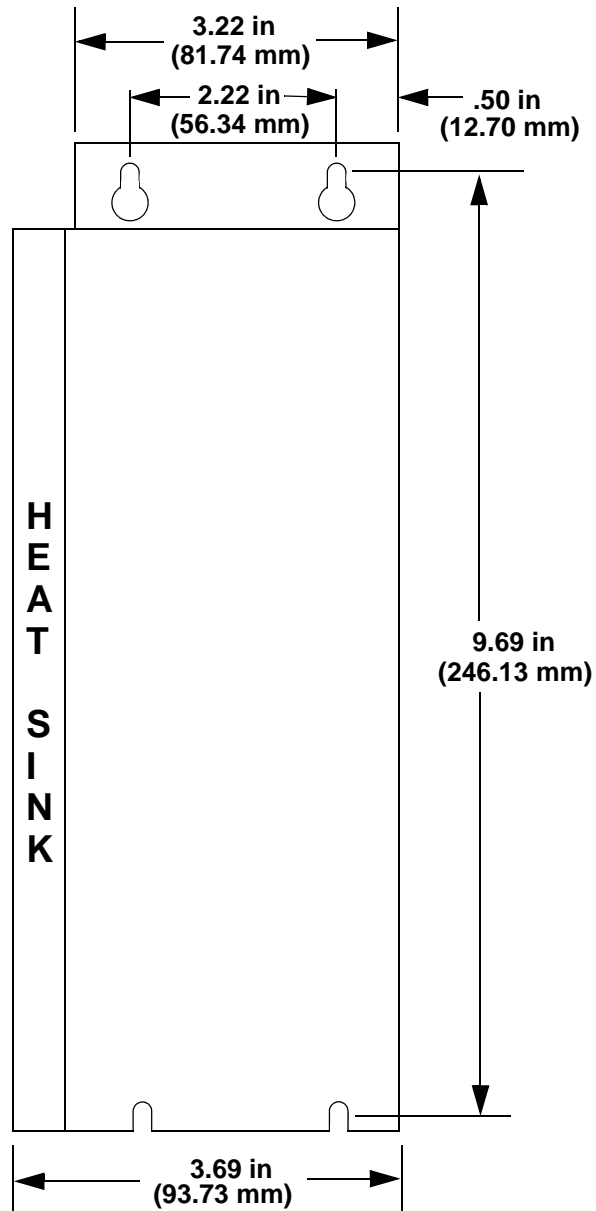


Figure 5-10: 1 kW & 2 kW Narrow Drive (-DN) - Front View

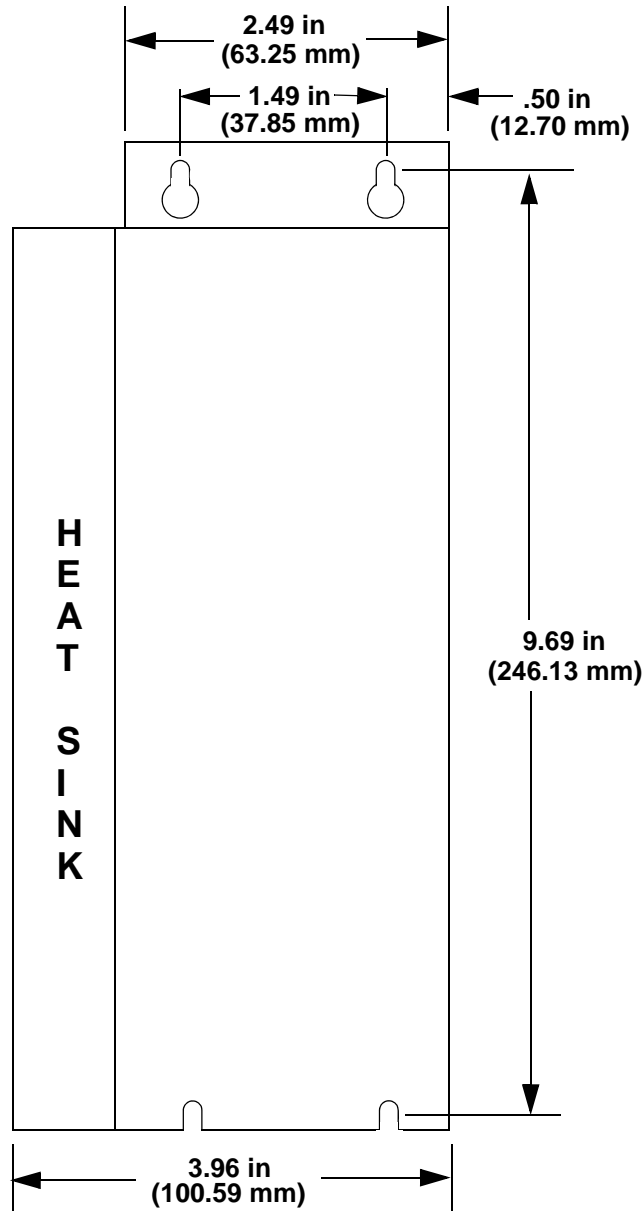


Figure 5-11: 1 kW & 2 kW Standard Drive (non-DN) - Front View

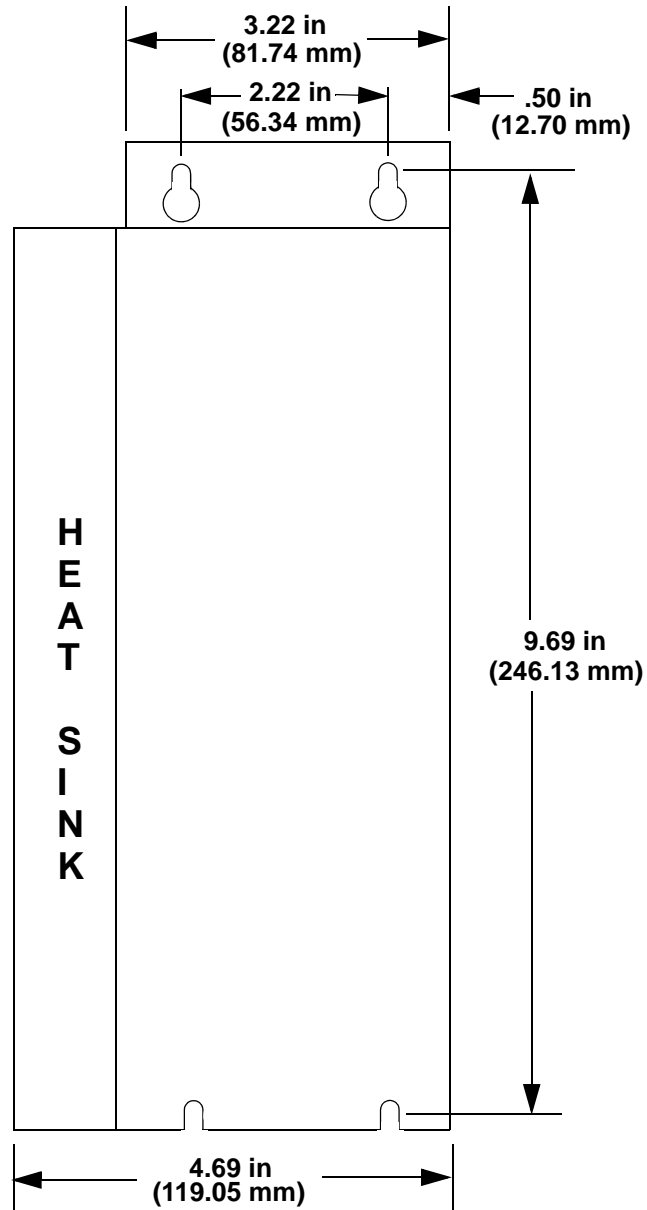
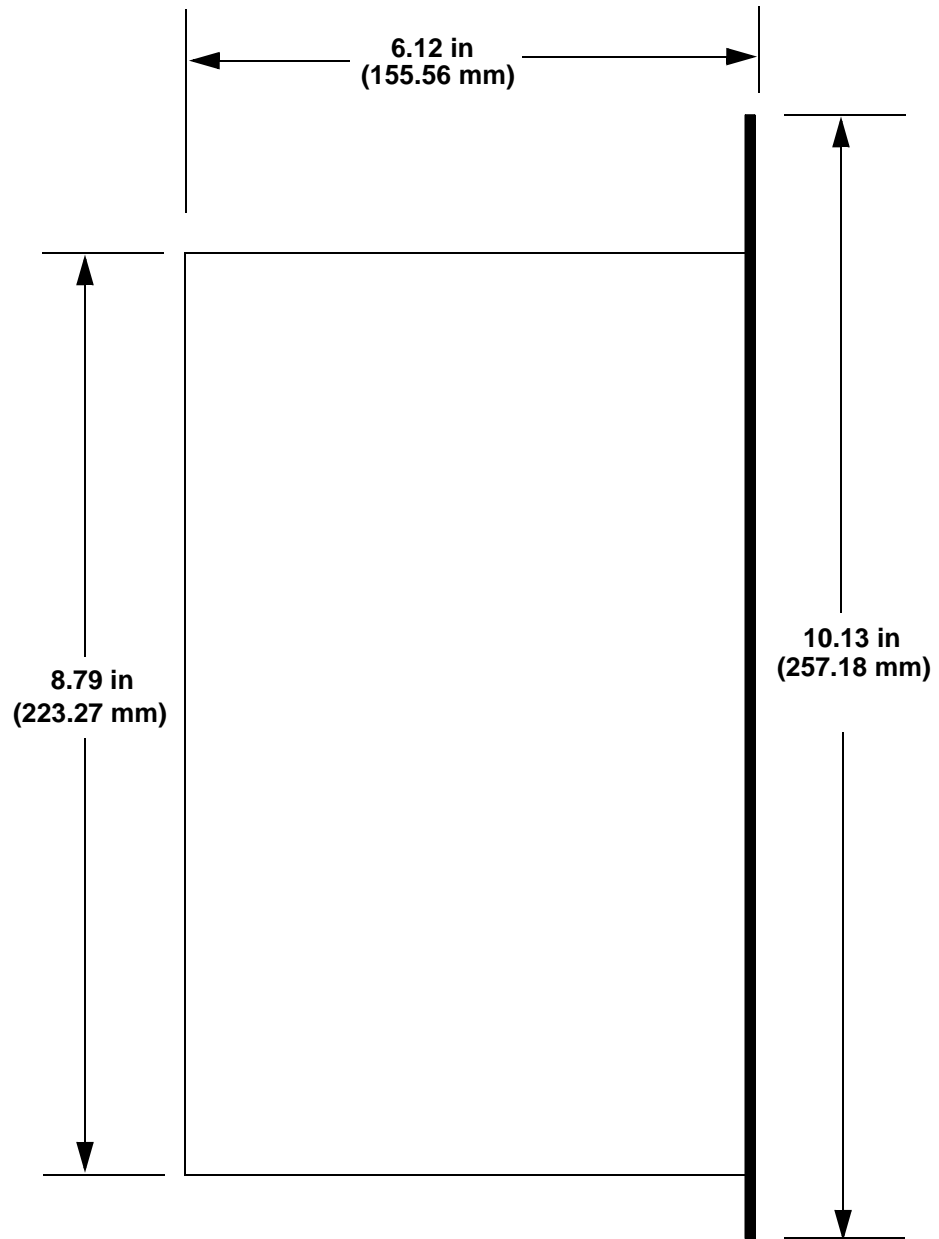


Figure 5-12: 230V Standard (non -DN) and Narrow (-DN) Drive - Side View



6 460V 3-Phase MMC Smart Drive

The 460V MMC Smart Drive is available in both analog and digital interfaced versions, with power ratings from 1.3kW through 65kW. This section describes these drives in detail.

6.1 Control Section Connectors, Switches, LEDs

The Control Section is located on the right side of the drive, and is identical to the Control Section on the 230V Smart Drive. Refer to [section 5.1 on page 63](#) for Information on the connectors, switches, and LEDs located on the Control Section of the drive.

6.2 Power Section Connectors

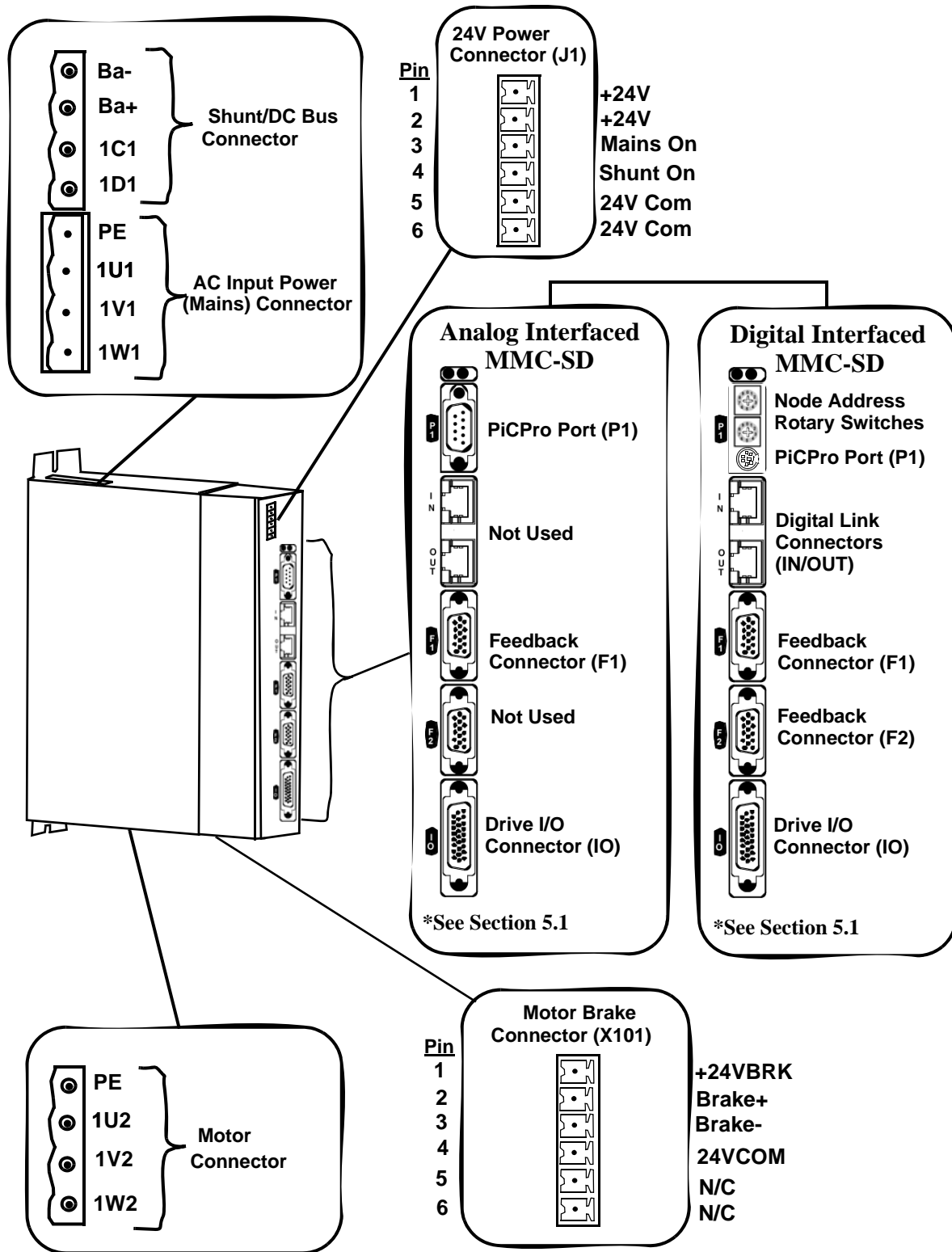
The 460V Smart Drive is available in four frame sizes (size 1 through 4). The Power Section connectors location and function are different among the four frame sizes. Each frame size is described in detail in the following sections.

6.2.1 Size 1 Power Section Connectors

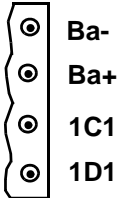
This section describes in detail the connectors located on the Power Section of the Size 1 drives.

The functionality and descriptions for the switches and connectors on the Control Section of the 460V MMC Smart Drives are the same as those on the 230V MMC Smart Drive. Refer to [section 5.1 on page 63](#) for more information.

Figure 6-1: Connectors on the Size 1 460V Smart Drive



6.2.1.1 Shunt/DC Bus Connector

Table 6-1: 460V Size 1 Shunt/DC Bus Connector				
Signal Type	Signal Description	Connector Label	In/Out	Connector
Power	External Shunt Resistor. Used to dissipate energy returned to the drive by the motor.	Ba-	Out	
		Ba+		
DC Bus Power	Direct DC bus connection	1C1 (ZK+)	N/A	
		1D1 (ZK-)		

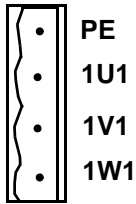
NOTE

The shunt resistor (if installed) across Ba+ and Ba- will be connected across the DC bus when the DC bus reaches the “shunt switch threshold” as shown in the specification table; or when the “Shunt On” input on the J1 connector is active.

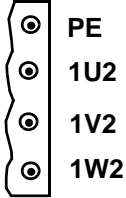
NOTE

If a 460V drive is connected to 220V to run a 220V motor, enable the “220V Shunt on 440V Drive” feature using PICPro, connect GPOUT3 on the Drive I/O (IO) connector to the “Shunt On” input on the J1 connector, and install the appropriate shunt resistor across the Ba+ and Ba- terminals. The shunt resistor will be applied across the DC bus when the DC bus voltage rises above 415 volts, and will be removed when the DC bus voltage falls below 400 volts.

6.2.1.2 AC Power Connector

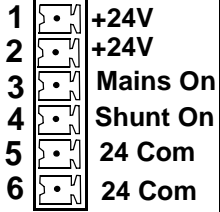
Table 6-2: 460V Size 1 AC Power Connector				
Signal Type	Signal Description	Connector Label	In/Out	Connector
Protective Ground	Protective Earth Ground	PE	Out	
Power	3 phase input power AC source must be center grounded Y system.	1U1	In	
		1V1		
		1W1		

6.2.1.3 Motor Connector

Table 6-3: 460V Size 1 Motor Connector				
Signal Type	Signal Description	Connector Label	In/Out	Connector
Protective Ground	Protective Earth Ground	PE	Out	
Power	Drive output power to motor.	1U2	Out	
		1V2		
		1W2		

6.2.1.4 24V Power Connector (J1)

Table 6-4: 460V Size 1 24V Power Connector (J1)

Signal Type	Signal Description	Pin	Connector Label	In/Out	Connector
Power	24 VDC input power	1	+24V	In	Top 
		2	+24V		
24V Logic Output	Reserved for future use, do not use!	3	Mains On	Out	
24V Logic Input	When this input is active, the shunt resistor (if installed) between Ba+ and Ba- is connected across the DC bus.	4	Shunt On	In	
Power	24 VDC input common to the drive.	5	24V Com	In	
		6	24V Com		

CAUTION

A possible ignition hazard within the MMC 460V Smart Drives exists if excessive current is drawn from the 24 VDC powering the MMC Smart Drive. To prevent this possibility (due to improper wiring or 24 VDC supply failure), a fuse should be used in series with the 24 VDC to the MMC Smart Drive (4 A max). In addition, the 24 VDC shall be supplied by an isolating source such that the maximum open circuit voltage available to the MMC Smart Drive is not more than 30 VDC.

6.2.1.5 Motor Brake Connector (X101)

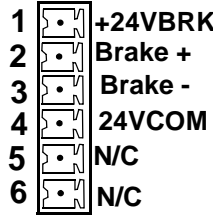
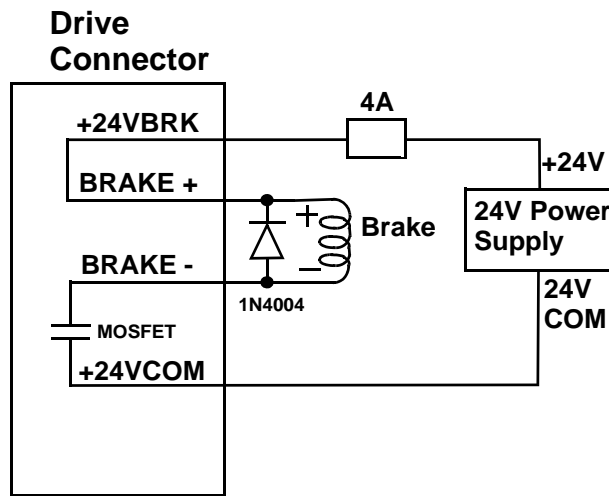
Table 6-5: 460V Size 1 Motor Brake Connector (X101)					
Signal Type	Signal Description	Pin	Connector Label	In/Out	Connector
Power	24 VDC brake input power	1	+24VBRK	In	<div style="text-align: center;">Top</div> 
Brake control	Brake connections	2	Brake +	Out	
		3	Brake -	In	
Power	24 VDC common	4	24VCOM	Out	
Not Used.		5	N/C	Not Used	
		6			

Figure 6-2: Wiring Example for X101 Connector

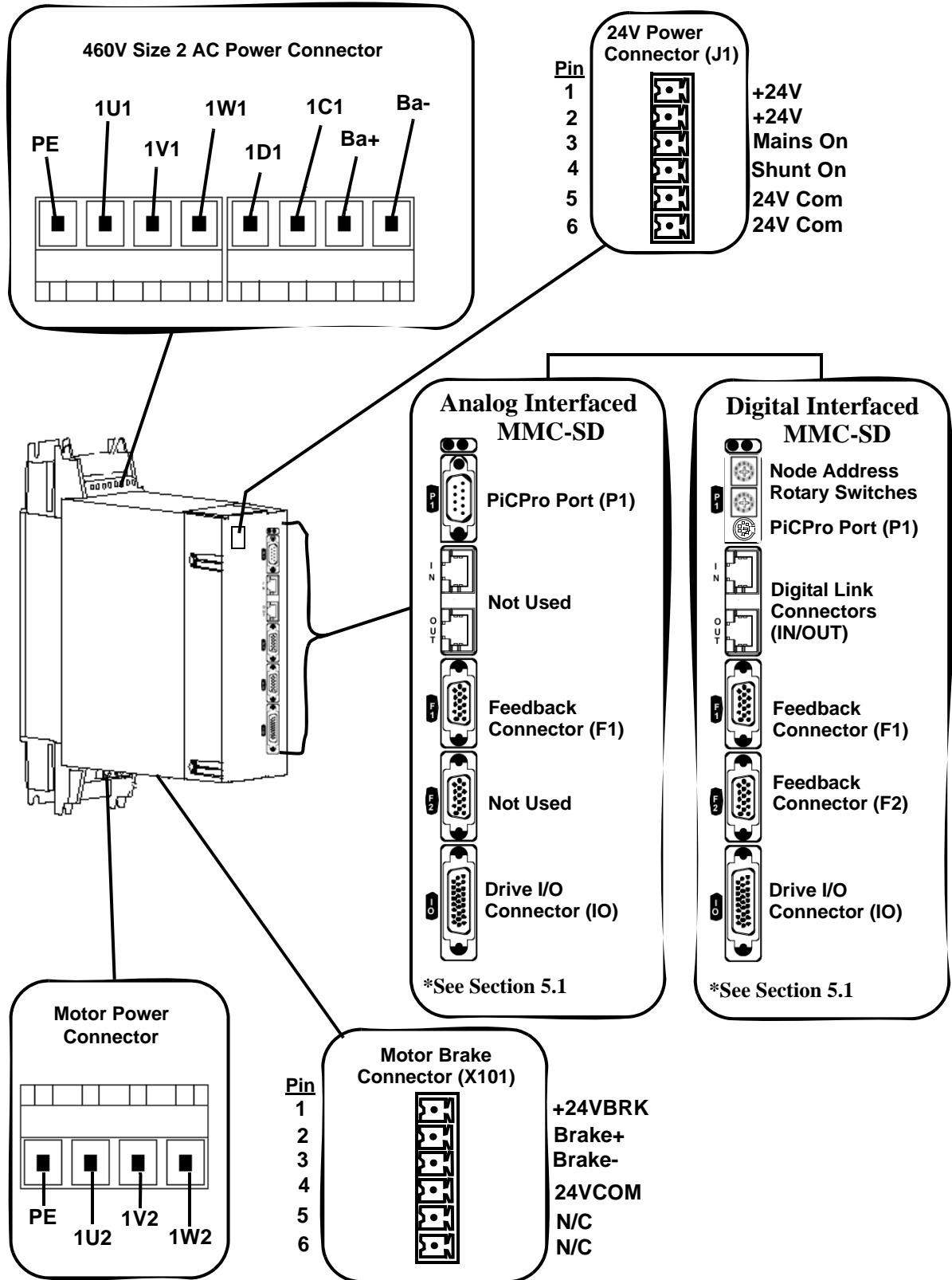


6.2.2 Size 2 Power Section Connectors

This section describes in detail the connectors located on the Power Section of the Size 2 drives.

The functionality and descriptions for the switches and connectors on the Control Section of the 460V MMC Smart Drives are the same as those on the 230V MMC Smart Drive. Refer to [section 5.1 on page 63](#) for more information.

Figure 6-3: Connectors on the Size 2 460V Drive



6.2.2.1 AC Power Connector

Table 6-6: 460V Size 2 AC Power Connector			
<p>The diagram shows a terminal block with eight terminals. From left to right, they are labeled: PE, 1U1, 1V1, 1W1, 1D1, 1C1, Ba+, and Ba-. Each terminal is represented by a square symbol with a dot in the center. Below the terminals are two rows of empty slots, representing the physical layout of the connector.</p>			
Signal Type	Signal Description	Connector Label	In/Out
Ground	Protective Ground (Earth)	PE	Out
Power	Three phase AC input power in to drive	1U1	In
		1V1	
		1W1	
DC Bus Power	Direct DC bus connection	1D1 (ZK-)	Out
		1C1 (ZK+)	
Power	External Shunt Resistor used to dissipate energy returned to the drive from motor	Ba+	Out
		Ba-	

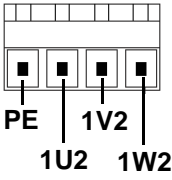
NOTE

The shunt resistor (if installed) across Ba+ and Ba- will be connected across the DC bus when the DC bus reaches the “shunt switch threshold” as shown in the specification table; or when the “Shunt On” input on the J1 connector is active.

NOTE

If a 460V drive is connected to 220V to run a 220V motor, enable the “220V Shunt on 440V Drive” feature using PicPro, connect GPOUT3 on the Drive I/O (IO) connector to the “Shunt On” input on the J1 connector, and install the appropriate shunt resistor across the Ba+ and Ba- terminals. The shunt resistor will be applied across the DC bus when the DC bus voltage rises above 415 volts, and will be removed when the DC bus voltage falls below 400 volts.

6.2.2.2 Motor Connector

Table 6-7: 460V Size 2 Motor Connector				
Signal Type	Signal Description	Connector Label	In/Out	Connector
Ground	Protective Ground (Earth)	PE	Out	 <p>The diagram shows a 4-pin connector with terminals labeled PE, 1U2, 1V2, and 1W2. The PE terminal is on the far left, followed by 1U2, 1V2, and 1W2 on the far right.</p>
Motor	Power U-phase from the drive to the motor	1U2	Out	
	Power V-phase from the drive to the motor	1V2	Out	
	Power W-phase from the drive to the motor	1W2	Out	

6.2.2.3 24V Power Connector (J1)

Table 6-8: 460V Size 2 24V Power Connector (J1)					
Signal Type	Signal Description	Pin	Connector Label	In/Out	Connector
Power	24 VDC input power	1	+24V	In	<p style="text-align: center;">Top</p>
		2	+24V		
24V Logic Output	Reserved for future use, do not use!	3	Mains On	Out	
24V Logic Input	When this input is active, the shunt resistor (if installed) between Ba+ and Ba- is connected across the DC bus.	4	Shunt On	In	
Power	24 VDC input common to the drive.	5	24V Com	In	
		6	24V Com		

CAUTION
<p>A possible ignition hazard within the MMC 460V Smart Drives exists if excessive current is drawn from the 24 VDC powering the MMC Smart Drive. To prevent this possibility (due to improper wiring or 24 VDC supply failure), a fuse should be used in series with the 24 VDC to the MMC Smart Drive. Specifically, a 4 A max. "UL248 Series" fuse should be used. In addition, the 24 VDC shall be supplied by an isolating source such that the maximum open circuit voltage available to the MMC Smart Drive is not more than 30 VDC.</p>

6.2.2.4 Motor Brake Connector (X101)

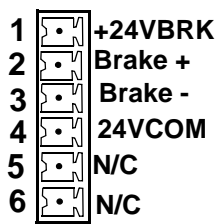
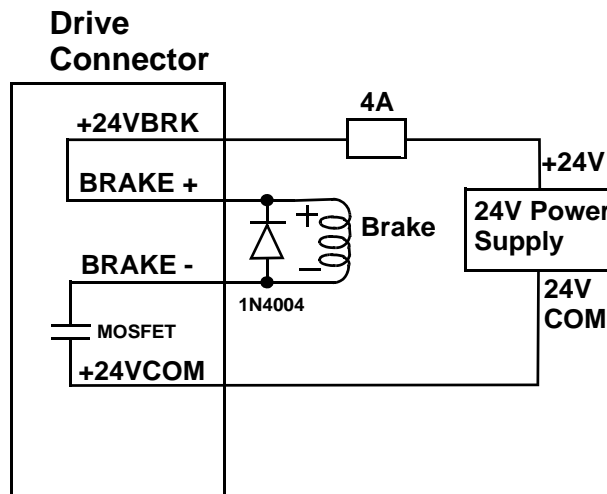
Table 6-9: 460V Size 2 Motor Brake Connector (X101)					
Signal Type	Signal Description	Pin	Connector Label	In/Out	Connector
Power	24 VDC brake input power	1	+24VBRK	In	<div style="text-align: center;"> Top  </div>
Brake control	Brake connections	2	Brake +	Out	
		3	Brake -	In	
Power	24 VDC common (supply and magnet)	4	24VCOM	Out	
Not Used.		5	N/C	Not Used	
		6			

Figure 6-4: Wiring Example for X101 Connector

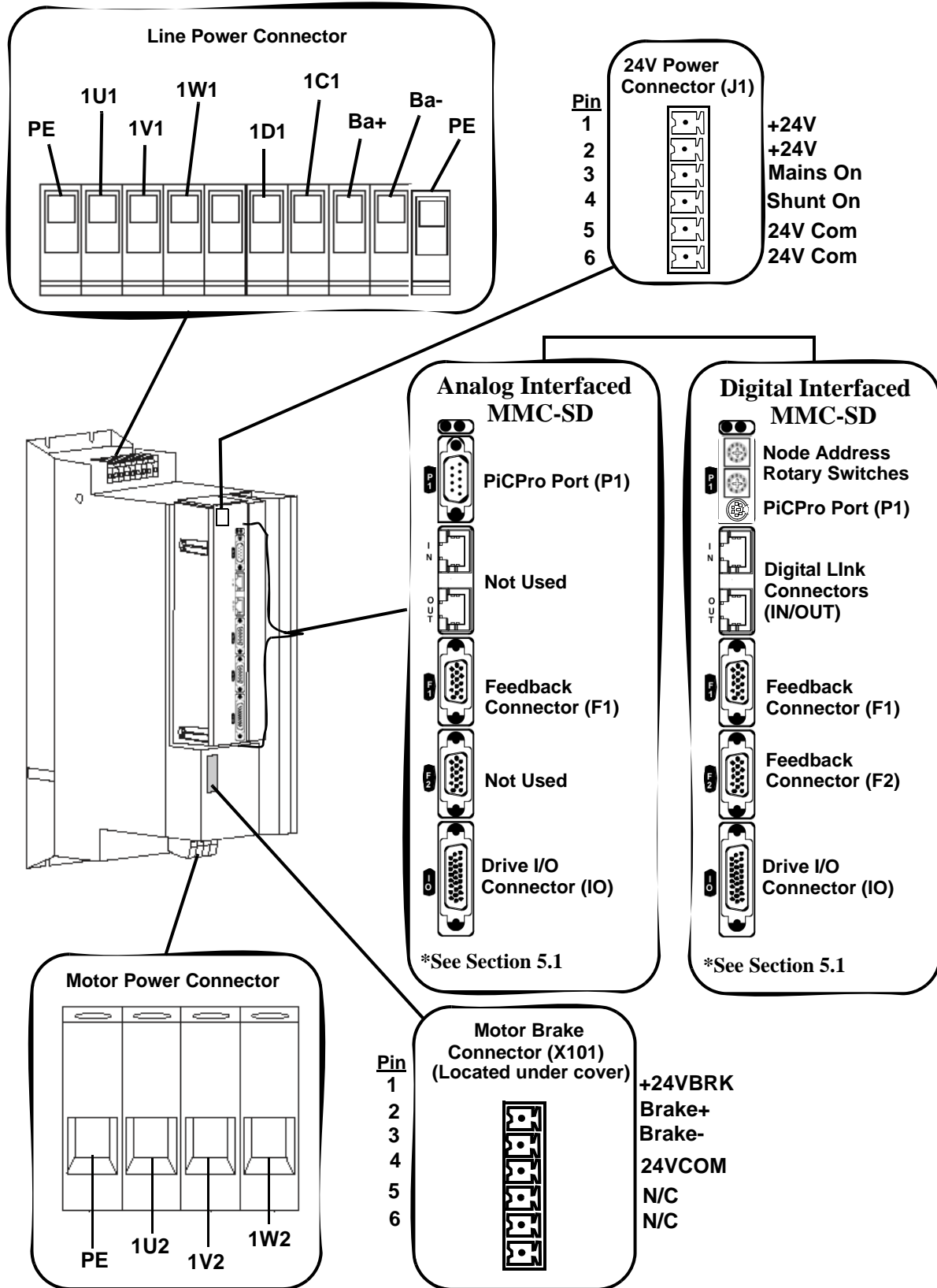


6.2.3 Size 3 Power Section Connectors

This section describes in detail the connectors located on the Power Section of the Size 3 drives.

The functionality and descriptions for the switches and connectors on the Control Section of the 460V MMC Smart Drives are the same as those on the 230V MMC Smart Drive. Refer to [section 5.1 on page 63](#) for more information.

Figure 6-5: Connectors on the Size 3 460V Drive



6.2.3.1 AC Power Connector

Table 6-10: 460V Size 3 AC Power Connector

Signal Type	Signal Description	Connector Label	In/Out
Ground	Protective Ground (Earth)	PE	Out
Power	Three phase AC input power in to drive	1U1	In
		1V1	
		1W1	
DC Bus Power	Direct DC bus connection	1D1 (ZK-)	Out
		1C1 (ZK+)	
	External Shunt Resistor used to dissipate energy returned to the drive from motor	Ba+	Out
		Ba-	

NOTE

The shunt resistor (if installed) across Ba+ and Ba- will be connected across the DC bus when the DC bus reaches the “shunt switch threshold” as shown in the specification table; or when the “Shunt On” input on the J1 connector is active.

NOTE

If a 460V drive is connected to 220V to run a 220V motor, enable the “220V Shunt on 440V Drive” feature using PicPro, connect GPOUT3 on the Drive I/O (IO) connector to the “Shunt On” input on the J1 connector, and install the appropriate shunt resistor across the Ba+ and Ba- terminals. The shunt resistor will be applied across the DC bus when the DC bus voltage rises above 415 volts, and will be removed when the DC bus voltage falls below 400 volts.

6.2.3.2 Motor Connector

Table 6-11: 460V Size 3 Motor Connector				
Signal Type	Signal Description	Connector Label	In/Out	Connector
Ground	Protective Ground (Earth)	PE	Out	<p>The diagram shows a vertical connector with four pins. From left to right, the pins are labeled: PE (Protective Earth), 1U2 (U-phase), 1V2 (V-phase), and 1W2 (W-phase). Each label is connected to its respective pin by a vertical line.</p>
Motor	Power U-phase from the drive to the motor	1U2	Out	
	Power V-phase from the drive to the motor	1V2	Out	
	Power W-phase from the drive to the motor	1W2	Out	

6.2.3.3 24V Power Connector (J1)

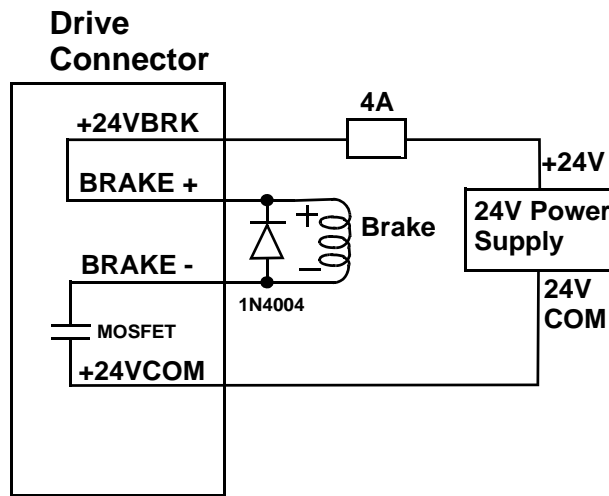
Table 6-12: 460V Size 3 24V Power Connector (J1)					
Signal Type	Signal Description	Pin	Connector Label	In/Out	Connector
Power	24 VDC input power	1	+24V	In	<p style="text-align: center;">Top</p>
		2	+24V		
24V Logic Output	Reserved for future use, do not use!	3	Mains On	Out	
24V Logic Input	When this input is active, the shunt resistor (if installed) between Ba+ and Ba- is connected across the DC bus.	4	Shunt On	In	
Power	24 VDC input common to the drive.	5	24V Com	In	
		6	24V Com		

CAUTION
<p>A possible ignition hazard within the MMC 460V Smart Drives exists if excessive current is drawn from the 24 VDC powering the MMC Smart Drive. To prevent this possibility (due to improper wiring or 24 VDC supply failure), a fuse should be used in series with the 24 VDC to the MMC Smart Drive. Specifically, a 4 A max. "UL248 Series" fuse should be used. In addition, the 24 VDC shall be supplied by an isolating source such that the maximum open circuit voltage available to the MMC Smart Drive is not more than 30 VDC.</p>

6.2.3.4 Motor Brake Connector (X101)

Table 6-13: 460V Size 3 Motor Brake Connector (X101)					
Signal Type	Signal Description	Pin	Connector Label	In/Out	Connector
Power	24 VDC brake input power	1	+24VBRK	In	<p style="text-align: center;">Top</p>
Brake control	Brake connections	2	Brake +	Out	
		3	Brake -	In	
Power	24 VDC common (supply and magnet)	4	24VCOM	Out	
Not Used.		5	N/C	Not Used	
		6			

Figure 6-6: Wiring Example for X101 Connector

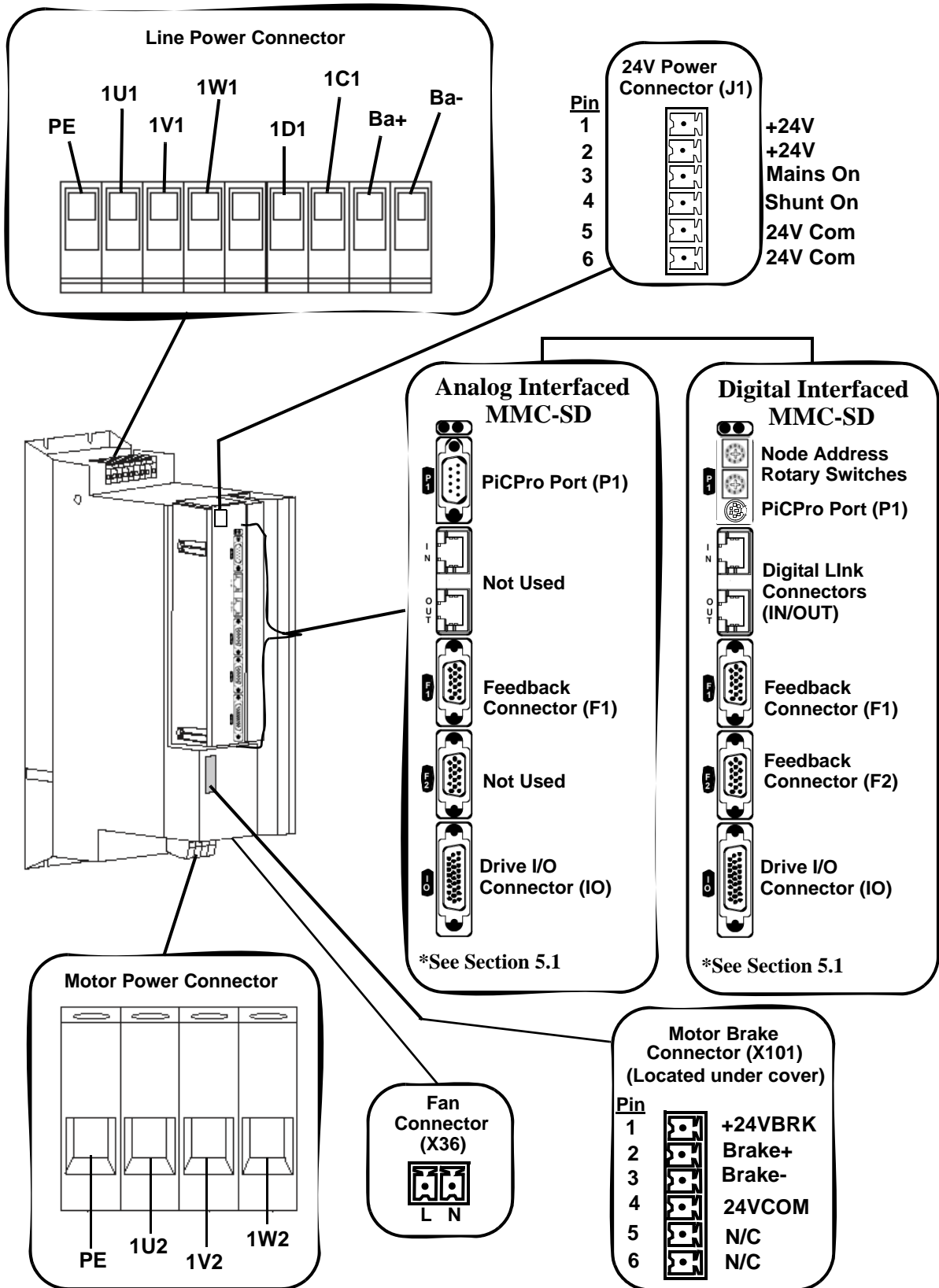


6.2.4 Size 4 Power Section Connectors

This section describes in detail the connectors located on the Power Section of the Size 4 drives.

The functionality and descriptions for the switches and connectors on the Control Section of the 460V MMC Smart Drives are the same as those on the 230V MMC Smart Drive. Refer to [section 5.1 on page 63](#) for more information.

Figure 6-7: Connectors on the Size 4 460V Drive



6.2.4.1 AC Power Connector

Table 6-14: 460V Size 4 AC Power Connector			
<p>The diagram shows a terminal block with eight terminals. From left to right, they are labeled: PE, 1U1, 1V1, 1W1, 1D1, 1C1, Ba+, and Ba-. The terminals are arranged in two rows of four. The top row contains PE, 1U1, 1V1, and 1W1. The bottom row contains 1D1, 1C1, Ba+, and Ba-. Below the terminals are two rows of empty slots for additional wiring.</p>			
Signal Type	Signal Description	Connector Label	In/Out
Ground	Protective Ground (Earth)	PE	Out
Power	Three phase AC input power in to drive	1U1	In
		1V1	
		1W1	
DC Bus Power	Direct DC bus connection	1D1 (ZK-)	Out
		1C1 (ZK+)	
	External Shunt Resistor used to dissipate energy returned to the drive from motor	Ba+	Out
		Ba-	

NOTE

The shunt resistor (if installed) across Ba+ and Ba- will be connected across the DC bus when the DC bus reaches the “shunt switch threshold” as shown in the specification table; or when the “Shunt On” input on the J1 connector is active.

NOTE

If a 460V drive is connected to 220V to run a 220V motor, enable the “220V Shunt on 440V Drive” feature using PicPro, connect GPOUT3 on the Drive I/O (IO) connector to the “Shunt On” input on the J1 connector, and install the appropriate shunt resistor across the Ba+ and Ba- terminals. The shunt resistor will be applied across the DC bus when the DC bus voltage rises above 415 volts, and will be removed when the DC bus voltage falls below 400 volts.

6.2.4.2 Motor Connector

Table 6-15: 460V Size 4 Motor Connector				
Signal Type	Signal Description	Connector Label	In/Out	Connector
Ground	Protective Ground (Earth)	PE	Out	<p>The diagram shows a vertical 4-pin connector. From left to right, the terminals are labeled: PE (Protective Earth), 1U2 (U-phase), 1V2 (V-phase), and 1W2 (W-phase). Each label has a vertical line pointing to its respective terminal.</p>
Motor	Power U-phase from the drive to the motor	1U2	Out	
	Power V-phase from the drive to the motor	1V2	Out	
	Power W-phase from the drive to the motor	1W2	Out	

6.2.4.3 24V Power Connector (J1)

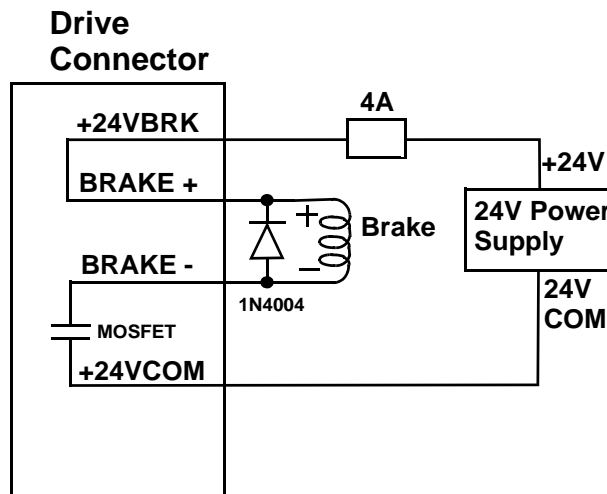
Table 6-16: 460V Size 4 24V Power Connector (J1)					
Signal Type	Signal Description	Pin	Connector Label	In/Out	Connector
Power	24 VDC input power	1	+24V	In	<p style="text-align: center;">Top</p>
		2	+24V		
24V Logic Output	Reserved for future use, do not use!	3	Mains On	Out	
24V Logic Input	When this input is active, the shunt resistor (if installed) between Ba+ and Ba- is connected across the DC bus.	4	Shunt On	In	
Power	24 VDC input common to the drive.	5	24V Com	In	
		6	24V Com		

CAUTION
<p>A possible ignition hazard within the MMC 460V Smart Drives exists if excessive current is drawn from the 24 VDC powering the MMC Smart Drive. To prevent this possibility (due to improper wiring or 24 VDC supply failure), a fuse should be used in series with the 24 VDC to the MMC Smart Drive. Specifically, a 4 A max. "UL248 Series" fuse should be used. In addition, the 24 VDC shall be supplied by an isolating source such that the maximum open circuit voltage available to the MMC Smart Drive is not more than 30 VDC.</p>

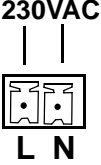
6.2.4.4 Motor Brake Connector (X101)

Table 6-17: 460V Size 4 Motor Brake Connector (X101)					
Signal Type	Signal Description	Pin	Connector Label	In/Out	Connector
Power	24 VDC brake input power	1	+24VBRK	In	<p style="text-align: center;">Top</p> <p>1 +24VBRK 2 Brake + 3 Brake - 4 24VCOM 5 N/C 6 N/C</p>
Brake control	Brake connections	2	Brake +	Out	
		3	Brake -	In	
Power	24 VDC common (supply and magnet)	4	24VCOM	Out	
Not Used.		5	N/C	Not Used	
		6			

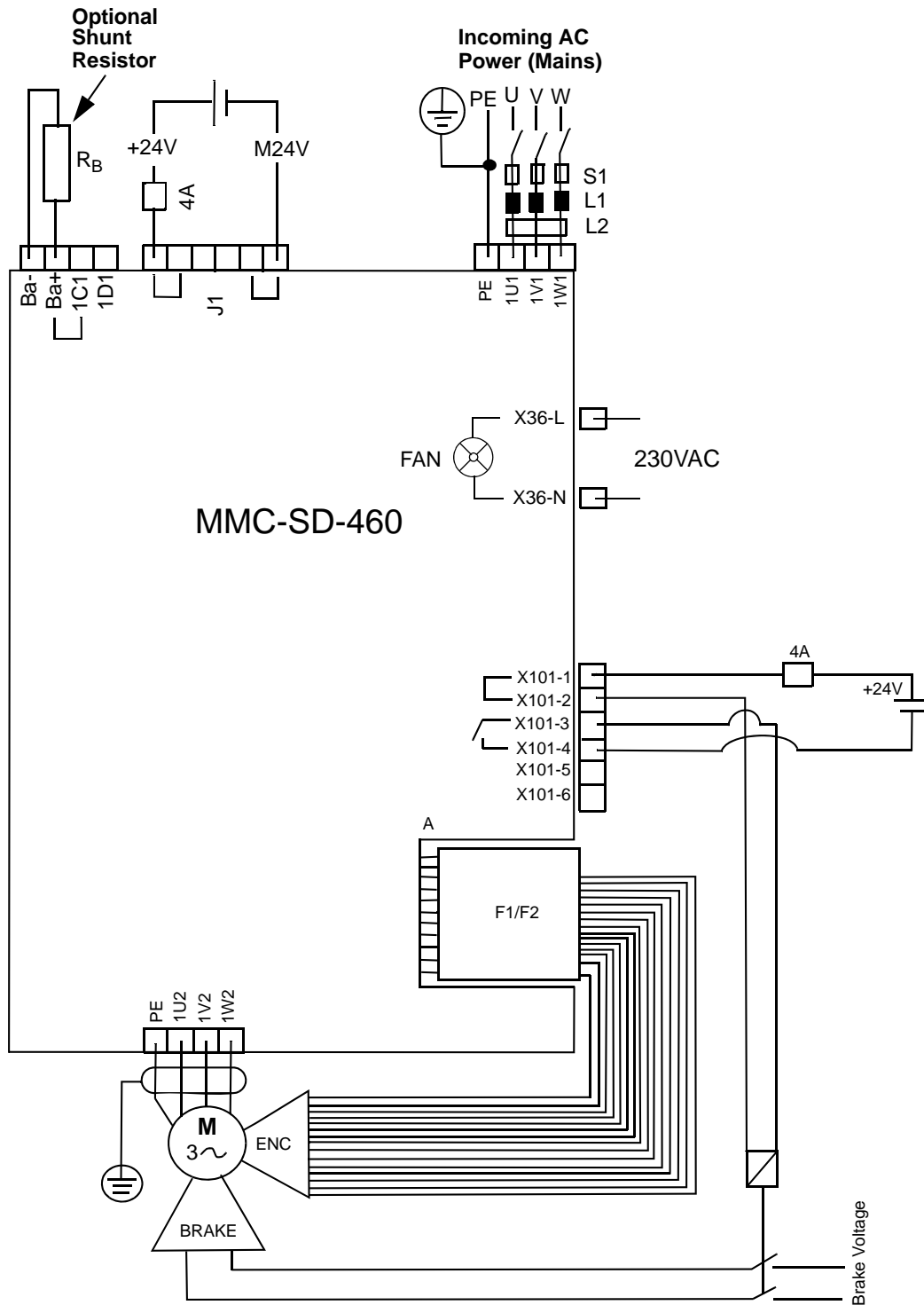
Figure 6-8: Wiring Example for X101 Connector



6.2.4.5 Fan Connector (X36)

Table 6-18: 460V Size 4 Fan Connector (X36)					
Signal Type	Signal Description	Pin	Connector Label	In/Out	Connector
Power	230VAC Line for powering the fan	1	L	In	<p>230VAC</p>  <p>L N</p>
Power	230VAC Neutral for powering the fan	2	N	In	

6.3 Typical 460V Drive Connection Layout



6.4 Specifications - 460V MMC Smart Drive)

6.4.1 Common Data for Size 1, 2, 3, 4 (All Models)

General Drive Data	
Minimum wire size for input power wires	1.5mm ² (16 AWG) 75° C copper
Maximum tightening torque for power wire terminals	1.25Nm (11 in-lbs.)
Commutation	3 Phase Sinusoidal, Space Vector Modulated (SVM)
Current Regulator	Digital PI 125 µsec update rate
Velocity Regulator	Digital PID - 250 µsec update rate
General Operating Data	
Operating Temperature Range (MMC-SD-1.3, -2.4, -4.0, -6.0, -8.0, -12.0, -16.0, -24.0)	7° C to 50° C (45° F to 122° F)
Operating Temperature Range (MMC-SD-30.0, -42.0, -51.0, -65.0)	7° C to 55° C (45° F to 131° F). Derate 3% per° C above 40° C.
Storage Temperature Range	-30° C to 70° C (-22° F to 158° F)
Humidity	5% to 95% non-condensing
Altitude	1500m (5000ft) Derate 3% for each 300 m above 1500m
Vibration Limits (per IEC 68-2-6) Operating/Non-operating	10-57Hz (constant amplitude .15mm) 57 - 2000Hz (acceleration 2g)
Shock (per IEC 68-2-27) Non-operating	15g/11msec per axis
F1 and F2 Feedback Inputs	
Input receiver type	Maxim 3098 A quad B differential RS422 receiver
Encoder signals	Differential quadrature
Input threshold	±200mV
Input termination	150Ω, provided internal
Maximum input voltage	5Vpp differential -10 to +13.2V common mode
Maximum input signal frequency	720KHz (2.88 M feedback unit count rate)

General Purpose Inputs	
Configuration	<ul style="list-style-type: none"> • 8 optically isolated 24V DC inputs • Active high • 6 are current sourcing only (current flow into input) • 2 are sink or source
Guaranteed On	15VDC
Guaranteed Off	5VDC
Time delay on	1ms max.
Time delay off	1ms max.
Input voltage	Nominal 24VDC, maximum 30VDC
General Purpose Outputs	
Configuration	<ul style="list-style-type: none"> • 4 optically isolated 24VDC outputs • Active high • Current sourcing only (current into load) • Short circuit and overload protected
Maximum current	50mA per output
Voltage range	24VDC +15%-10%
Time delay on for resistive loads	50µsec. max
Time delay off for resistive loads	50µsec. max
Leakage current in off state	0.5mA max
Command Input/Output	
Command Input	Analog velocity or torque, 0 to $\pm 10V$ 14 bit effective resolution
Digital Link In/Out Ports (Digital Interfaced MMC-SD only)	
"In" port	Sends and receives high speed data to and from connected MMC-SD's "Out" port.
"Out" port	Sends and receives high speed data to and from connected MMC-SD's "In" port.
Cable Type	Shielded, Straight Pinned, CAT5 or better (CAT5e, CAT6, etc.)
Maximum Cable Length	30m (98.4 ft)

Drive I/O Connector Encoder Emulation Output		
F1 Motor Feedback Type	Input Limit	Encoder Emulation Output (A quad B Differential Output)
Incremental Encoder	720KHz 2.88 M counts/sec.	The motor encoder A/B/I inputs are electrically buffered and retransmitted via the Drive I/O connector.
High Resolution Encoder	100KHz 400K counts/sec.	The encoder SIN/COS signals are electrically squared and retransmitted as A/B. The index mark "I" is synthesized by the drive control DSP. Absolute position information is not available via the Encoder Emulation Output.
Resolver	500RPS 2.00M counts/sec.	The field-installable resolver interface module converts the motor resolver to 1024 lines/4096 counts per revolution of A/B encoder output. The module synthesizes the index mark "I" once per revolution of the resolver. Absolute position information is not available via the Encoder Emulation Output.
Conformity		
CE Marked	Conforms to Low Voltage Directive 73/23/EEC (amended by 93/68/EEC) and EMC Directive 89/336/EEC (amended by 92/31/EEC and 93/68/EEC). Conformance is in accordance with the following standards: EN 50178 and EN61800-3	
UL and C/UL Listed	E233454	

6.4.2 Physical/Electrical Data for 460V Size 1 Smart Drives

	Model	
	MMC-SD-1.3-460 (-D)	MMC-SD-2.4-460 (-D)
Part Numbers		
Analog	M.1302.5093	M.1302.5094
Digital, no BiSS	M.1302.8133	M.1302.8134
Digital, BiSS	M.3000.0464	M.3000.0465
Physical		
Weight	10 lbs.	
Electrical Specifications		
AC Input Specifications		
Nominal Input Power	1.94kVA	3.33kVA
Input Voltage	207-460 VAC (nominal), Three Phase, 187-528 VAC	
Input Frequency	47-63Hz	
Nominal Input	2.44A RMS	4.18A RMS
NOTE: Nominal Input Current is specified for nominal input voltage of 460 VAC.		
Maximum Inrush	4.56A RMS	7.81A RMS
Power Loss	34W	60W
AC Output Specifications		
Continuous Output Current RMS (0-Peak)	2.1A (3.0A)	3.9A (5.5A)
Continuous Output Power		
Input = 230 VAC	.65kW	1.2kW
Input = 460 VAC	1.3kW	2.4kW
Peak Output Current (0-Peak)	6.0A	11.0A
Output Frequency	0-450Hz	
DC Input Power Specifications (24VDC)		
Input Voltage Range	24VDC +15% -10%	
Typical Input Current	700mA	
Typical Input Wattage	17W	
Inrush Current	4A for 10ms	

Internal Holding Brake Driver		
Maximum Current	0.5A	
Energy Absorbtion Specifications		
DC Bus Capacitance (Internal)	110 μ F	240 μ F
Shunt Switch Threshold	780VDC	
Joules available for energy absorption		
230V motor w/ 230V line input	3 joules	7 joules
460V motor w/ 230V line input	28 joules	60 joules
460V motor w/ 460V line input	10 joules	22 joules
External Shunt		
Maximum shunt resistor current	5.9A (AC)	
Minimum shunt resistor	130 Ω	
Maximum shunt resistor power at minimum shunt resistor	4.5kW	5kW

6.4.3 Physical/Electrical Data for 460V Size 2 Smart Drives

	Model		
	MMC-SD-4.0-460 (-D)	MMC-SD-6.0-460 (-D)	MMC-SD-8.0-460 (-D)
Part Numbers Analog Digital, no BiSS Digital, BiSS	M.1302.5095 M.1302.8135 M.3000.0466	M.1302.5096 M.1302.8136 M.3000.0467	M.1302.5097 M.1302.8137 M.3000.0468
Physical			
Weight	16 lbs.		
Electrical Specifications			
AC Input Specifications			
Nominal Input Power	5.6kVA	8.6kVA	11.8kVA
Input Voltage	207-460 VAC (nominal), Three Phase, 187-528 VAC (absolute limits)		
Input Frequency	47-63Hz		
Nominal Input Current	7A RMS	10.8A RMS	14.8A RMS
NOTE: Nominal Input Current is specified for nominal input voltage of 460 VAC. Approximate Current for input voltages between 400 and 480 VAC = (listed current) x input voltage/460			
Maximum Inrush Current	13.2A RMS	20.2A RMS	27.7A RMS
Power Loss	102W	150W	204W
AC Output Specifications			
Continuous Output Current RMS (0-Peak)	6.4A (9.0A)	9.6A (13.5A)	12.7A (18.0A)
Continuous Output Power			
Input = 230 VAC	2.0kW	3.0kW	4.0kW
Input = 460 VAC	4.0kW	6.0kW	8.0kW
Peak Output Current (0-peak)	18.0A	27.0A	36.0A
Output Frequency	0Hz to 450Hz		

Internal Holding Brake Driver			
Maximum Current	0.5A		
DC Input Power Specifications (24VDC)			
Input Voltage Range	24VDC +15% -10%		
Typical Input Current	1050mA		
Typical Input Wattage	25W		
Inrush Current	4A for 10ms		
Energy Absorbtion Specifications			
DC Bus Capacitance (Internal)	470 μ F	705 μ F	
Shunt Switch Threshold	780VDC		
Joules available for energy absorption			
230V motor w/230V line input	13 joules	19 joules	
460V motor w/230V line input	188 joules	177 joules	
460V motor w/460V line input	44 joules	66 joules	
External Shunt			
Maximum shunt resistor current	9A (AC)	9A (AC)	9A (AC)
Minimum shunt resistor	86 Ω	60 Ω	44 Ω
Maximum shunt resistor power at minimum shunt resistor	7kW	10kW	14kW

6.4.4 Physical/Electrical Data for 460V Size 3 Smart Drives

	Model			
	MMC-SD-12.0-460 (-D)	MMC-SD-16.0-460 (-D)	MMC-SD-24.0-460 (-D)	MMC-SD-30.0-460-D
Part Numbers Analog Digital, no BiSS Digital, BiSS	M.1302.5098 M.1302.8138 M.3000.0469	M.1302.5099 M.1302.8139 M.3000.0470	M.1302.5100 M.1302.8140 M.3000.0471	M.3000.0545 N/A M.3000.0021
Physical				
Weight	35 lbs.			
Electrical Specifications				
AC Input Specifications				
Nominal Input Power	13.3kVA	16.8kVA	26.3 kVA	36.7 kVA
Input Voltage	207-460VAC (nominal), Three Phase, 187-528VAC (absolute limits)			
Input Frequency	47-63Hz			
Nominal Input Current	16.7A RMS	21.1A RMS	33.1A RMS	44.0A RMS
NOTE: Nominal Input Current is specified for nominal input voltage of 460 VAC. Approximate Current for input voltages between 400 and 480 VAC = (listed current) x 460/input voltage				
Maximum Inrush Current	32.2A RMS	39.2A RMS	61.8A RMS	tbdA RMS
Power Loss	300W	390W	600W	840W
AC Output Specifications				
Continuous Output Current RMS (0-Peak)	19.5A (27.5A)	25.8A (36.5A)	38.9A (55.0A)	(49.0A (69.3A))
Continuous Output Power				
Input = 230 VAC	6.0kW	8.0kW	12.0kW	15.0kW
Input = 460 VAC	12.0kW	16.0kW	24.0kW	30.0kW
Peak Output Current (0-peak)	55.0A	73.0A	110.0A	110.0A
Output Frequency	0Hz to 450Hz			

Internal Holding Brake Driver				
Maximum Current	0.5A		1.0A	
DC Input Power Specifications (24VDC)				
Input Voltage Range	24VDC +15% -10%			
Typical Input Current	1750mA			
Typical Input Wattage	42W			
Inrush Current	4A for 10ms			
Energy Absorbtion Specifications				
DC Bus Capacitance (Internal)	820 μ F	1230 μ F	1640 μ F	2000 μ F
Shunt Switch Threshold	780VDC			
Joules available for energy absorption				
230V motor w/ 230V line input	22 joules	33 joules	45 joules	553 joules
460V motor w/ 230V line input	206 joules	309 joules	412 joules	502 joules
460V motor w/ 460V line input	76 joules	114 joules	152 joules	185 joules
External Shunt				
Maximum shunt resistor current	36A (AC)		50A (AC)	
Minimum shunt resistor	22 Ω		16 Ω	
Maximum shunt resistor power at minimum shunt resistor	29kW		40kW	

6.4.5 Physical/Electrical Data for 460V Size 4 Smart Drives

	Model		
	MMC-SD-42.0-460-D	MMC-SD-51.0-460-D	MMC-SD-65.0-460-D
Part Numbers Analog Digital, BiSS	M.3000.0546 M.3000.0022	M.3000.0547 M.3000.0023	M.3000.0548 M.3000.0024
Physical			
Weight	59 lbs.		
Electrical Specifications			
AC Input Specifications			
Nominal Input Power	48.5kVA	58.2kVA	72.1kVA
Input Voltage	207-460VAC (nominal), Three Phase, 187-528VAC (absolute limits)		
Input Frequency	47-63Hz		
Nominal Input Current	58A RMS	72A RMS	95A RMS
NOTE: Nominal Input Current is specified for nominal input voltage of 460 VAC. Approximate Current for input voltages between 400 and 480 VAC = (listed current) x 460/input voltage			
Maximum Inrush Current	tbdA RMS	tbdA RMS	tbdA RMS
Power Loss	1080W	1350W	1740W
AC Output Specifications			
Continuous Output Current RMS (0-Peak)	66.0A (93.3A)	83.2A (117.4A)	108.0A (152.7A)
Continuous Output Power			
Input = 230 VAC	21.0kW	25.1kW	32.5kW
Input = 460 VAC	42.0kW	51.0kW	65.0kW
Peak Output Current (0-peak)	147A	189A	209A
Output Frequency	0Hz to 450Hz		
Internal Holding Brake Driver			
Maximum Current	4.0A		

DC Input Power Specifications (24VDC)			
Input Voltage Range	24VDC +15% -10%		
Typical Input Current	3.2A		
Typical Input Wattage	77W		
Inrush Current	tbdA for tbdms		
Energy Absorbtion Specifications			
DC Bus Capacitance (Internal)	1880 μ F	2350 μ F	3055 μ F
Shunt Switch Threshold	780VDC		
Joules available for energy absorption			
230V motor w/ 230V line input	50.4joules	63.1joules	82joules
460V motor w/ 230V line input	472joules	591joules	768joules
460V motor w/ 460V line input	173joules	218joules	284joules
External Shunt			
Maximum shunt resistor current	67A (AC)	100A (AC)	100A (AC)
Minimum shunt resistor	12 Ω	8 Ω	8W
Maximum shunt resistor power at minimum shunt resistor	53kW	80	80kW
Fan (X36 Connector)			
Input Voltage	230VAC (nominal), 207VAC to 253VAC, 50/60HZ		
Input Current	1A Max		
Power Loss	87W		

6.5 Dimensions for the 460V Smart Drives

Figure 6-9: Size 1 460V Smart Drive - Front View

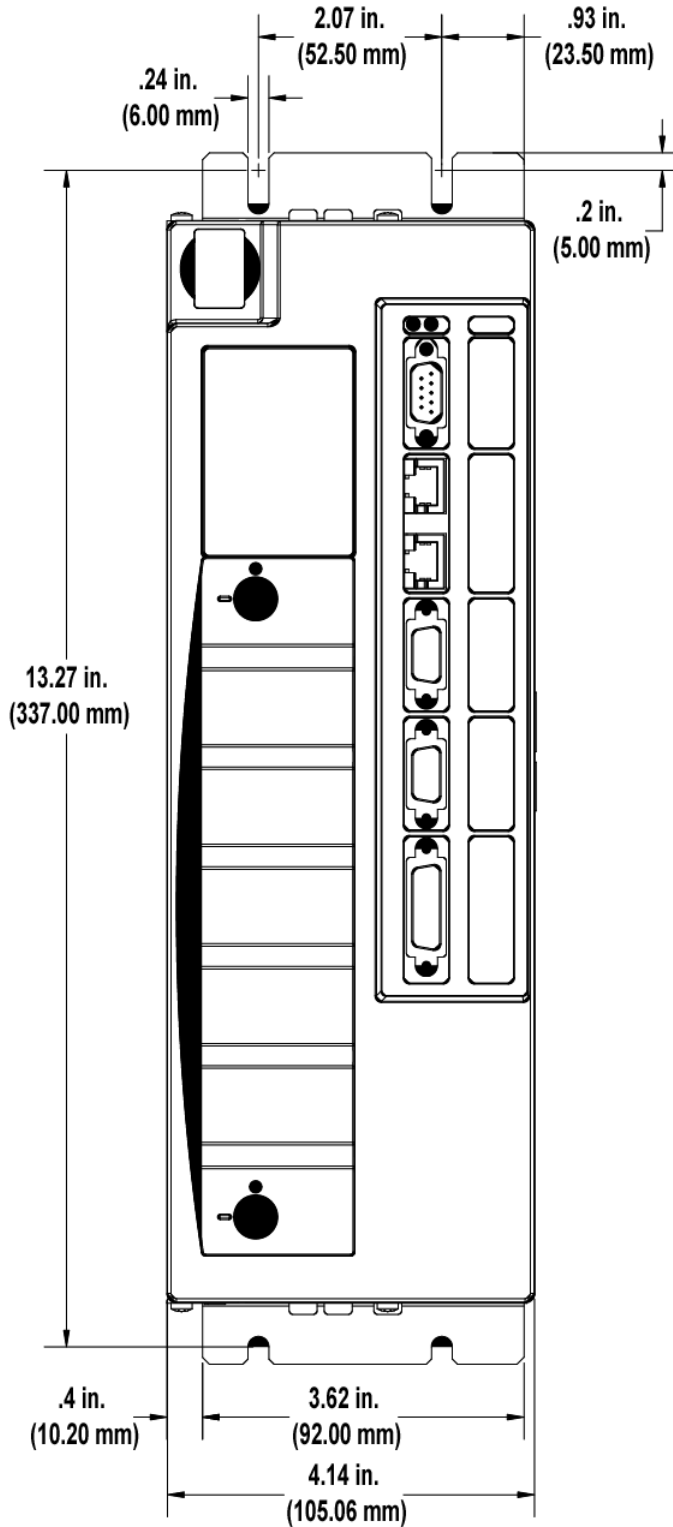


Figure 6-10: Size 1 460V Smart Drive - Side View

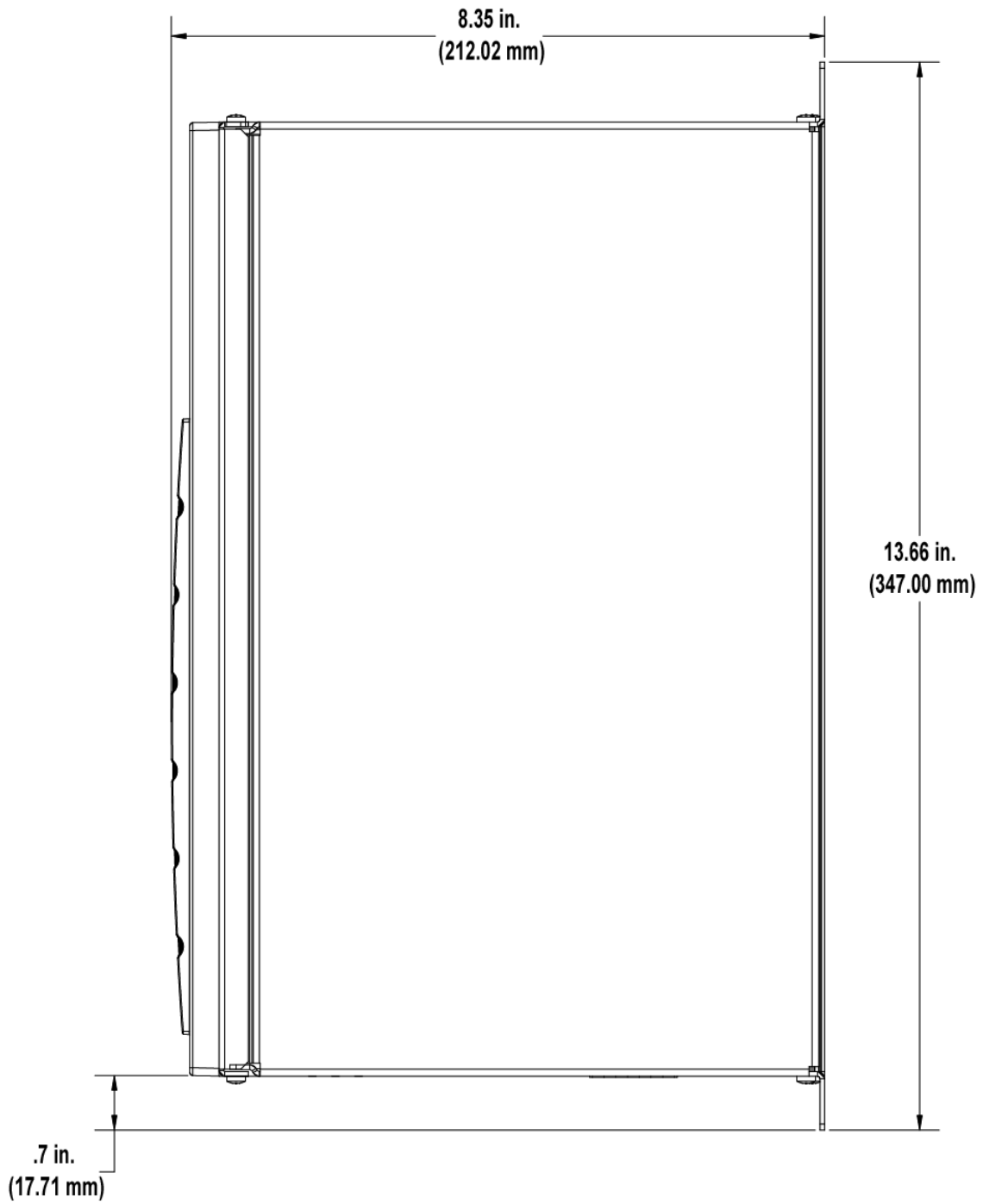


Figure 6-11: Size 2 460V Smart Drive - Front View

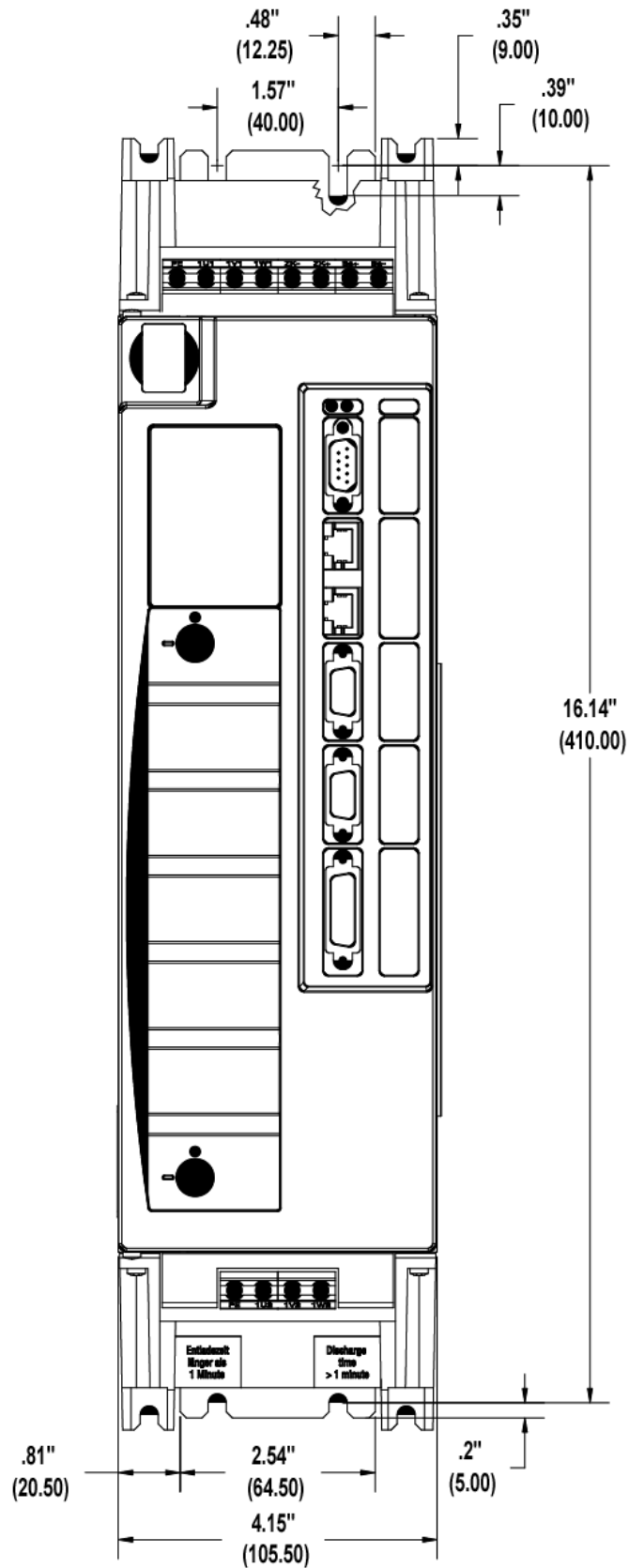


Figure 6-12: Size 2 460V Smart Drive - Side View

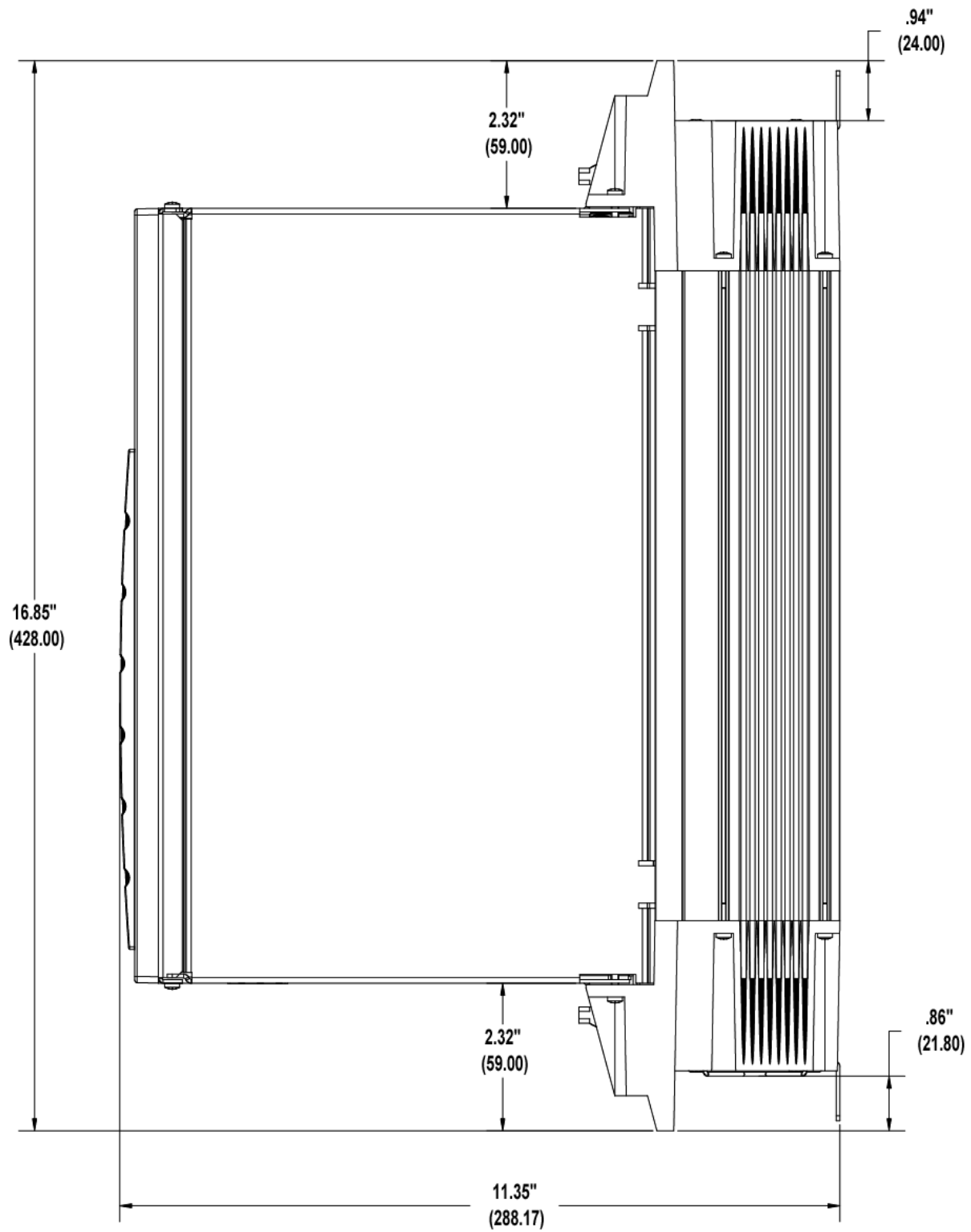


Figure 6-13: Size 3 460V Smart Drive - Front View

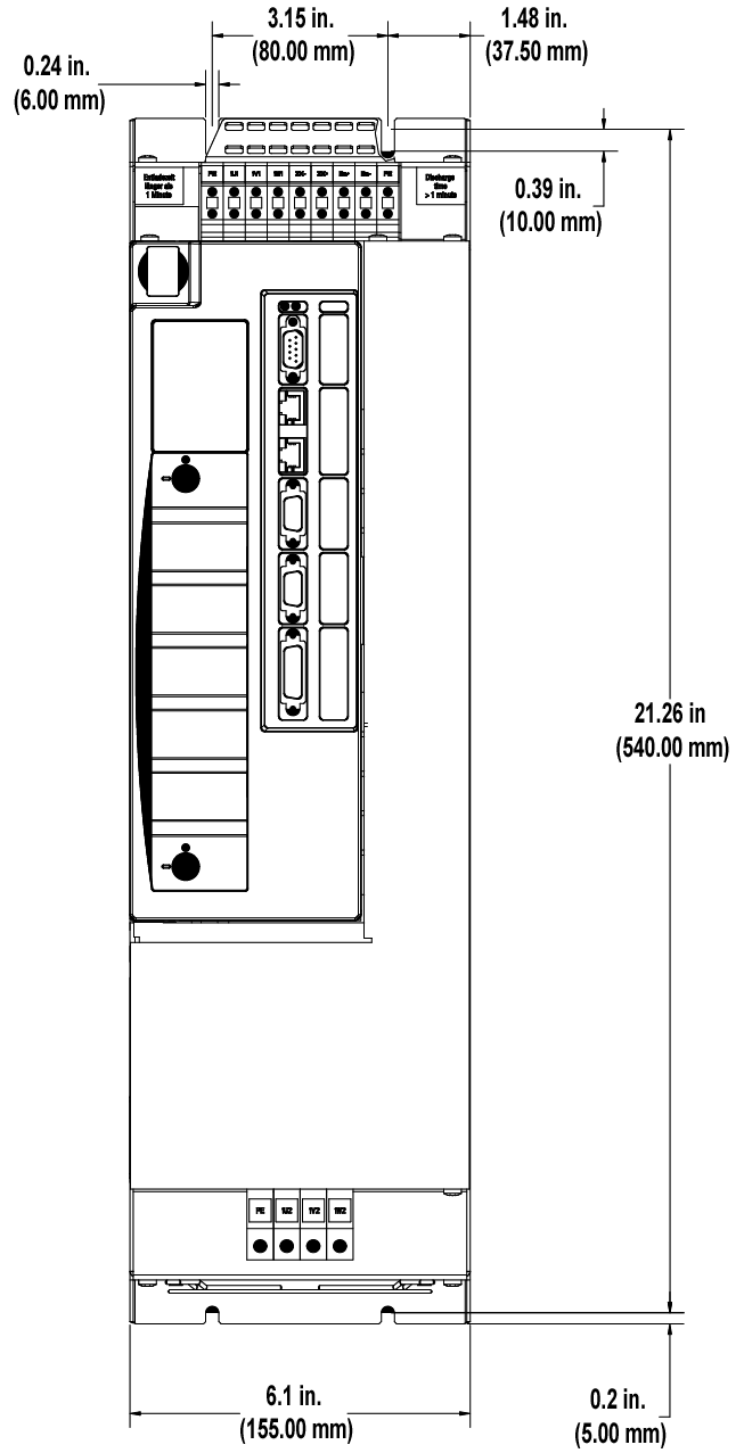


Figure 6-14: Size 3 460V Smart Drive - Side View

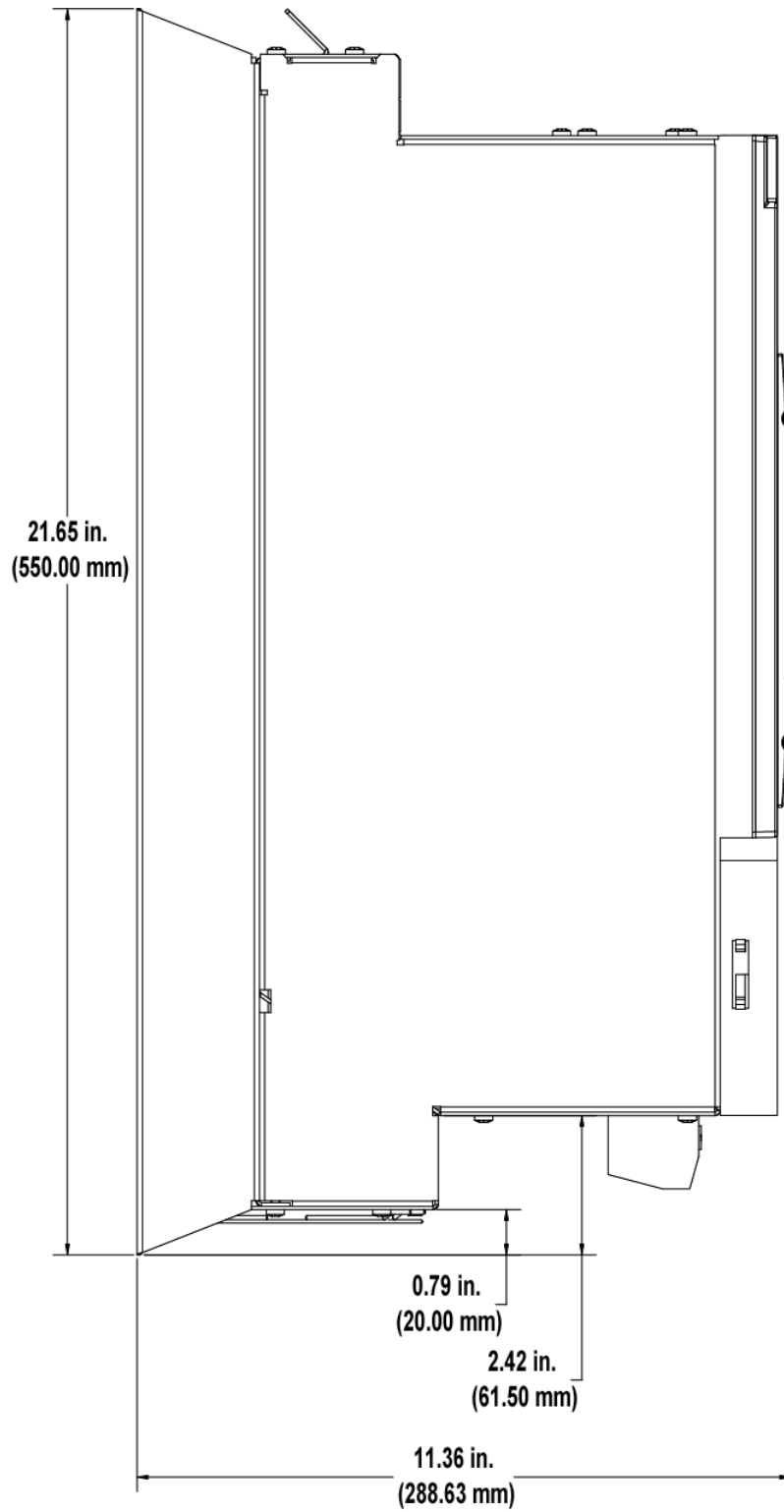


Figure 6-15: Size 4 460V Smart Drive - Front View

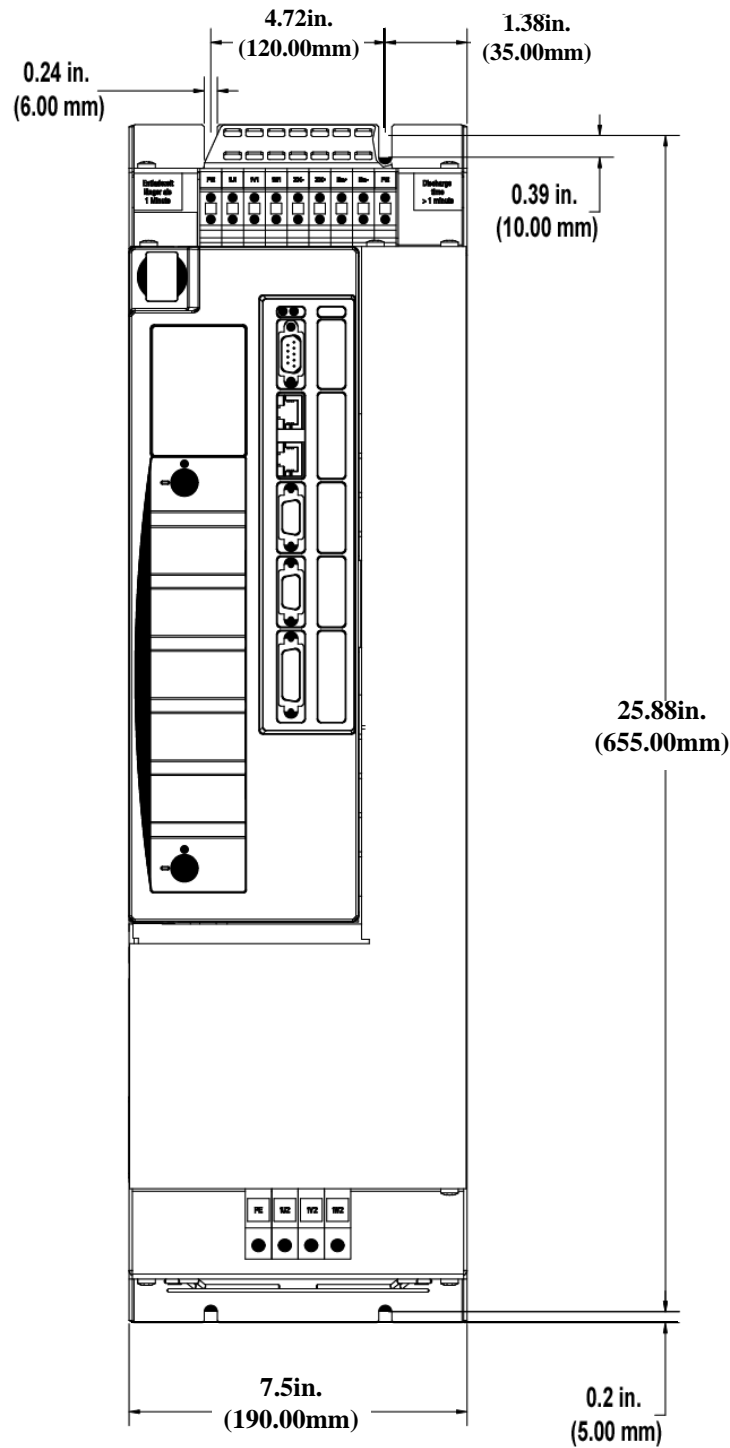
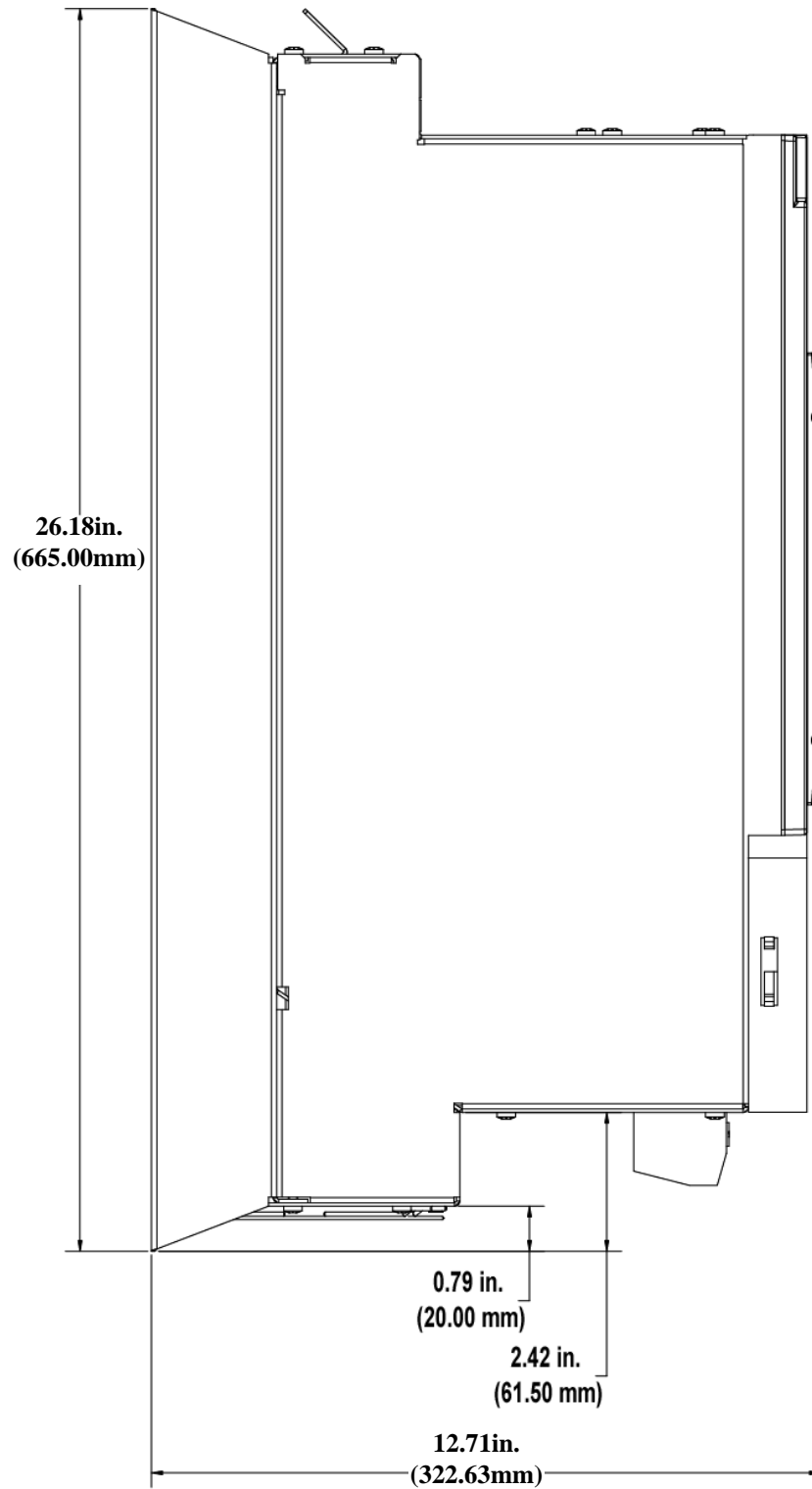


Figure 6-16: Size 4 460V Smart Drive - Side View



7 S200-DLS Drive

This chapter only pertains to the S200-DLS Drive, not to the MMC Smart Drive.

The S200-DLS consists of a Base Unit with an S200 Digital Link Option Card installed. The combination of the two components is the S200-DLS Drive. The Base Unit is described in detail in Kollmorgen's S200 Base Unit Reference Manual, P/N M-SM-200-01, which can be found at http://www.kollmorgen.com/website/com/eng/products/drives/ac_servo_drives/s200_manuals.php. Please refer to the S200 Base Unit Reference Manual for Base Unit Specifications, Mounting information, Wiring information, etc. The Base Unit has the same Part Number as the Digital Link version, except that the -DLS is replaced with -VTS. For example, a S20360-DLS consists of an S20360-VTS Base Unit and an S200 Digital Link Option Card.

Any data or specification contained in this manual takes precedence over conflicting data or specifications found in the Base Unit manual.

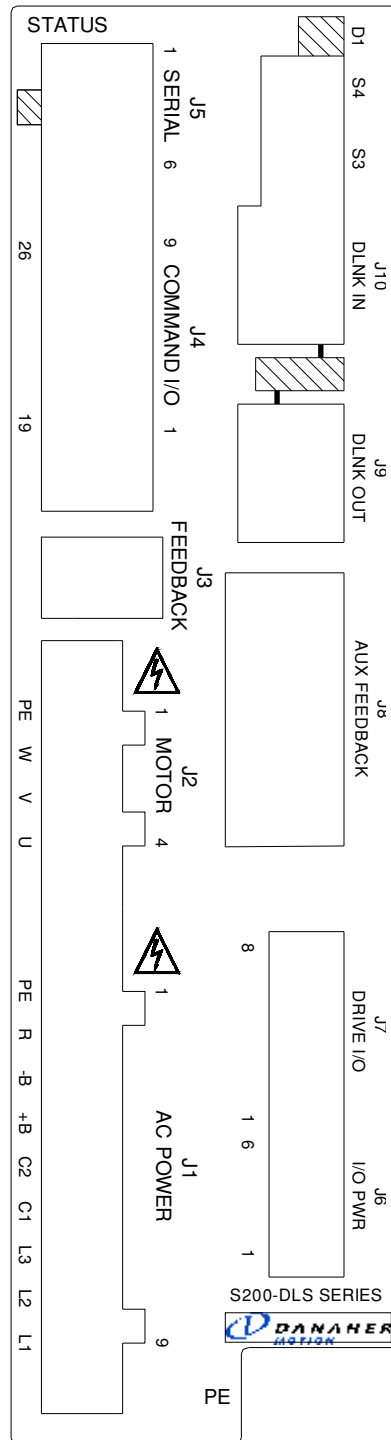
CE ENCLOSURE REQUIREMENTS

In order to meet the requirements of the CE Directives, the S200-DLS drive(s) must be mounted within a grounded metal enclosure. Additional actions may also be required, as described in the S200 Base Unit Reference Manual, mentioned above.

BISS ENCODER SUPPORT

In order to use a BiSS encoder with the S200-DLS drive, the drive must be Rev 3 or later (as found on the drive label), and the firmware within the drive must be Version 2.03 or later.

Figure 7-1:



7.1 S200-DLS Option Card

The S200 Option Card is located on the right side of the S200-DLS Drive. This section explains in detail the various indicators and connectors located on the S200 Option Card.

7.1.1 LED Indicators

There are three LED Indicators on the front of the Option Card, as described in [Table 7-1](#).

LED	Color	Description
Diagnostic	Yellow	The Diagnostic LED (labeled "D1" on the front of the Drive), located in the top of the Option Card, serves as the Option Card Status indicator, and provides Option Card status and fault information.
Digital Link LEDs	Green	These LEDs, located between the "DLINK IN" and "DLINK OUT" connectors, provide Digital Link status information.

7.1.2 Diagnostic Indicator Details

The Diagnostic Indicator LED (labeled "D1" on the front of the Drive) performs various functions:

- When Control Power is applied to the Drive, the Diagnostic LED turns on briefly as the Option Card runs internal power-on diagnostics. If the diagnostics pass, the Diagnostic LED goes off.
- If the Diagnostic LED is flashing after the power-on diagnostics are complete, there is a problem with the Drive. See [section 9.2.3.1 on page 185](#) for blink code details.
- While the Drive is operating, the Option Card is constantly monitoring Drive operation and performance. If a Warning or Fault condition is detected, the Diagnostic LED will blink. See [section 9.2.3.1 on page 185](#) for blink code details.

7.1.3 Digital Link LEDs

There are two green LED indicators located between the "DLINK IN" and "DLINK OUT" connectors.

- The right-most LED is associated with the "DLINK IN" connector, and indicates that the Drive is that another "upstream" device (either another Digital Link drive or a Digital Control) is connected and successfully communicating with the Drive.
- The left-most LED is associated with the "DLINK OUT" connector, and indicates that the Drive is connected and successfully communicating with the another "downstream" Drive.

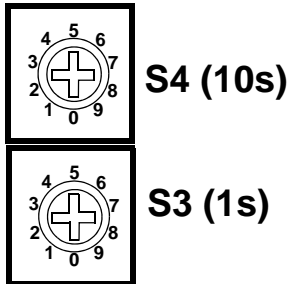
7.1.4 Node Address Rotary Switches

Two rotary switches are used to set the drive address. Rotate the switch to the desired address.

Addresses can be set to any number from 1 through 64. The top switch represents values of base ten. The bottom switch represents values of base 1.

As an example, rotating the top switch (S3) to a setting of 2 equals the value of 20 (2 x 10). Rotating the bottom switch (S4) to a setting of 5 equals the value of 5. The actual address setting is 25 (20 + 5).

Figure 7-2: Node Address Switches



7.1.5 Digital Link Ports

The two 8-pin RJ-45 Digital Link Port connectors (labeled “J10 DLINK IN” and “J9 DLINK OUT” on the front of the Drive) provide communications between the S200-DLS and:

- another S200-DLS Drive
- an MMC Smart Drive (including a Drive that contains a Drive Resident MMC Control)
- an MMC-DSA Control (MMC-DSA2, -DSA4, -DSA8, -DSA16)
- a Digital Standalone MMC Control (MMC-D32, -D64)

Also provided are two green “Link” lights located between the RJ-45 connectors. The right light will be on if there is a Drive or Digital Control connected to the “IN” port, and the left light will be on if there is a Drive connected to the “OUT” port.

A “straight-through” shielded cable must be used when connecting to another device. Connect the cable from the Drive’s “DLINK OUT” port to the next Drive’s “DLINK IN” port, or from the MMC Digital Control’s Digital Link port to the Drive’s “DLINK IN” port. Refer to the Standalone MMC Hardware Manual for Standalone Digital Control information.

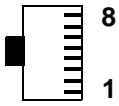
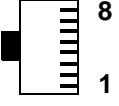
- Pin descriptions for are provided in [Table 7-2](#)
- Pin assignments are provided in [Table 7-3](#)
- The available Digital Link Port to Digital Drive cables are described in [Table 7-4](#)

Table 7-2: Digital Link Port Pin Description

Digital Link Connector (IN/OUT) Signals		Pin	
Function	Notes	“In” Connector	“Out” Connector
Receive Data+/-	Receives data from connected drives.	1,2	3,6
Transmit Data +/-	Transmits data to connected drives.	3,6	1,2
Protective Ground	Shield connection. Provides a path for the ground signal to an external single point ground.	Connector Shell	Connector Shell

Table 7-3: Digital Link Port Pin Assignments

Pin	Label	In/Out	Connector Pinout
IN Connector			<p>RJ-45 Connectors</p>
1	Receive +	In	
2	Receive -	In	
3	Transmit +	Out	
4	Not Used	N/A	
5	Not Used	N/A	
6	Transmit -	Out	
7	Not Used	N/A	
8	Not Used	N/A	
Connector Shield	Provides a path for the ground signal to an external single point ground.	In	
OUT Connector			
1	Transmit +	Out	
2	Transmit -	Out	
3	Receive +	In	
4	Not Used	N/A	
5	Not Used	N/A	
6	Receive -	In	
7	Not Used	N/A	
8	Not Used	N/A	
Connector Shield	Provides a path for the ground signal to an external single point ground.	In	

Table 7-4: Digital Link Port “IN” to “OUT” Cables				
Part Numbers: .3 M (1.0 ft): M.1302.8285 .6 M (2.0 ft): M.1302.8286 1 M (3.3 ft): M.1302.8287 2 M (6.6 ft): M.1302.8288 3 M (9.8 ft): M.1302.8289 5 M (16.4 ft): M.1302.8300 10 M (32.8 ft): M.1302.8301 15 M (49.2 ft): M.1302.8302 30 M (98.4 ft): M.1302.8303 Cable type: CAT-5 (or better), 28 AWG, shielded, twisted pair, 8 conductor.				
8-Pin RJ-45 Plug (to Digital Link Port “OUT”, face view) 		8-Pin RJ-45 Plug (to Digital Drive “IN”, face view) 		
Pin	Signal	Pin	Signal	Notes
1	Transmit Data +	1	Receive Data +	Twisted Pair
2	Transmit Data -	2	Receive Data -	
3	Receive Data +	3	Transmit Data +	Twisted Pair
6	Receive Data -	6	Transmit Data -	
4	None	4	None	Twisted Pair
5	None	5	None	
7	None	7	None	Twisted Pair
8	None	8	None	
Shell	Drain	Shell	Drain	

7.1.6 Auxiliary Feedback Port

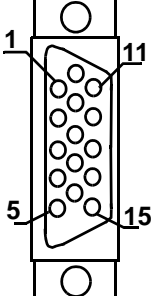
The 15-pin female Auxiliary Feedback connector (labeled “J8 AUX FEEDBACK” on the front of the Drive) provides the interface between the S200-DLS Drive and a feedback device.

- Pin descriptions are provided in [Table 7-5](#)
- Pin assignments are provided in [Table 7-6](#)
- The available Flying Lead cable is described in [Table 7-7](#).
- Available Breakout Boxes and Cables are described in [Table 7-8](#).
- Breakout Box dimensions are shown in [Figure 7-3](#)
- Breakout Board dimensions are shown in [Table 7-4](#)

Table 7-5: Aux Feedback Port Pin Description

Aux Feedback Signals			
Signal Type	Signal Name	Notes	Pin
Incremental Encoder Inputs	A1, A1/, B1, B1/, I1, I1/	Differential A quad B encoder signals.	1, 2, 3, 4, 5, 10
BiSS Encoder Data Channel In/Out ^a	RS-485 Data +, RS-485 Data -, RS-485 Clock+, RS-485 Clock-	RS-485 signals for connecting a BiSS Encoder Data Channel to the drive	5, 10, 12, 13
Motor Commutation Hall Sensor Inputs	Commutation Track S1, S2, S3	Hall device input signals that are used to initialize the commutation angle. They consist of a 74HC14 input with 10 μ s filter and 1 K pull up to +5V. Shared with F2.	12, 13, 8
Temperature Input	Temperature	Thermostat (normally- closed) or Thermistor (Phillips KTY84-130 PTC or equivalent recommended) input for detecting over temperature conditions within the motor.	11
+5V Encoder Power Outputs	+5V Source	Regulated +5VDC for powering the attached encoder (250ma max).	14
Signal and Power Common	Common	Return path for feedback signals and +5V power supply.	6

a. In order to use a BiSS encoder with the S200-DLS drive, the drive must be Rev 3 or later (as found on the drive label), and the firmware within the drive must be Version 2.03 or later.

Table 7-6: Aux Feedback Port Pin Assignments				
Encoder Pin Assignments for Aux Feedback 15 Pin Connector				
Pin	Feedback Device		In/Out	Connector Pinout
	Digital Incremental Encoder	Endat ^a BISS ^b SSI ^a		
1	A1	N/U	In	15-pin Female HD D-Sub 
2	A1/	N/U		
3	B1	N/U		
4	B1/	N/U		
5	I1	RS-485 Data+	Note ^c	
6	Common		In/Out	
7	N/U		N/A	
8	Commutation Track S3	N/U	In	
9	N/U		N/A	
10	I1/	RS-485 Data-	Note ^c	
11	Temperature		In	
12	Commutation Track S1	RS-485 Clock+	In ^d	
13	Commutation Track S2	RS-485 Clock-		
14	+5V Source		Out	
15	N/U		N/A	
Shell	Shield		N/A	

a. For future use

b. In order to use a BiSS encoder with the S200-DLS drive, the drive must be Rev 3 or later (as found on the drive label), and the firmware within the drive must be Version 2.03 or later

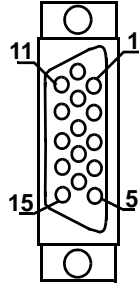
c. Pins 5 and 10 are In/Out for Endat, and Inputs for Digital Incremental, SSI, and BiSS

d. Pins 12 and 13 are Outputs for ENDAT, SSI, and BiSS

Table 7-7: Aux Feedback Port to Flying Lead Cable

Part Numbers: 1 M (3.3 ft): M.3000.8005 3 M (9.8 ft): M.3000.8006
 6 M (19.7 ft): M.3000.8007 9 M (19.5 ft): M.3000.8008
 Cable type: 28 AWG (pins 6 & 14 16 AWG), shielded, twisted pair, 16 conductor.

15-Pin HD male D-sub (to Aux Feedback Port, face view)

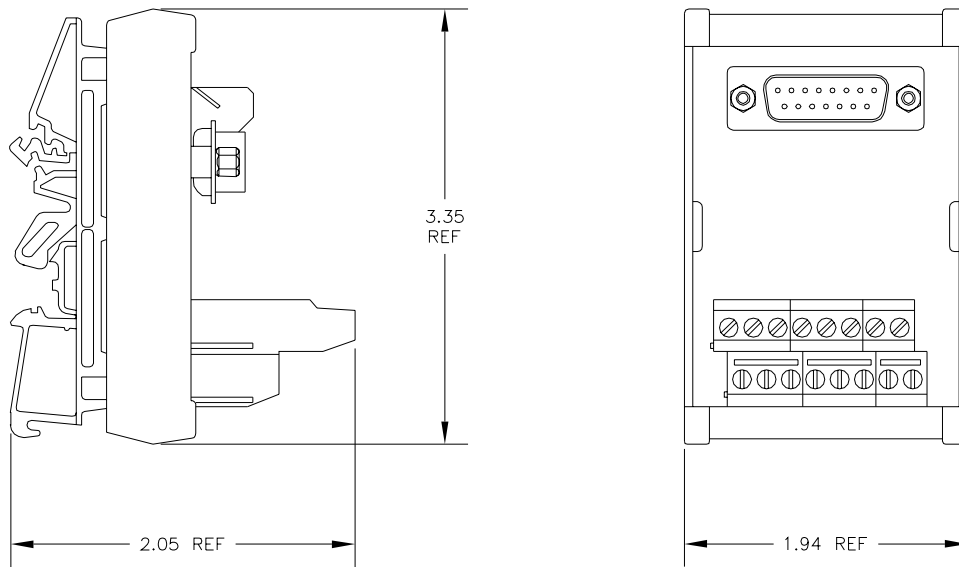


Pin	Signal	Color	Notes
1	A1	White	Twisted
2	A1/	White/Yellow	Pair
3	B1	Blue	Twisted
4	B1/	White/Blue	Pair
5	I1, RS-485 Data+	Black	Twisted
10	I1/, RS-485 Data-	White/Black	Pair
8	Commutation Track S3	Red	Twisted
	Not Connected	White/Red	Pair
14	+5V source	Gray	Twisted
6	Common	White/Gray	Pair
11	Temperature	Green	Twisted
	Not Connected	White/Green	Pair
12	Commutation Track S1, RS-485 Clock+	Violet	Twisted
13	Commutation Track S2, RS-485 Clock-	White/Violet	Pair
	Not Connected	Orange	Twisted
	Not Connected	White/Orange	Pair
7	Not Used	Brown	Twisted
	Not Connected	White/Brown	Pair
Shell	Drain	N/A	

Description	Length	Part Number
Aux Feedback Port Breakout Board ^a	N/A	M.1302.6970
Aux Feedback Port Breakout Box ^b	N/A	M.1302.6972
Aux Feedback Port to Breakout Box Cable	1 M (3.3 ft)	M.3000.8001
	3 M (9.8 ft)	M.3000.8002
	6 M (19.7 ft)	M.3000.8003
	9 M (29.7ft)	M.3000.8004

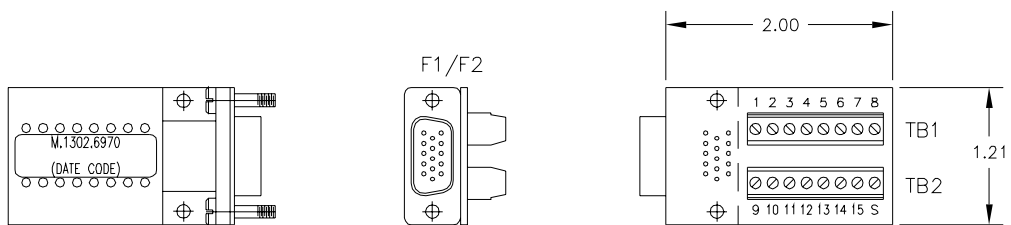
- a. The Breakout Board (see [Figure 7-3 on page 162](#)) is mounted directly to the Aux Feedback connector, and provides screw terminals wire termination.
- b. The Breakout Box (see [Figure 7-4 on page 162](#)) is DIN-rail mounted, and provides screw terminal wire termination. Use one of the cables listed in the table to connect between the Aux Feedback connector and the Breakout Box.

Figure 7-3: Aux Feedback Port Breakout Box Dimensions



D15 SUB/P
PART NO. M.1302.6972

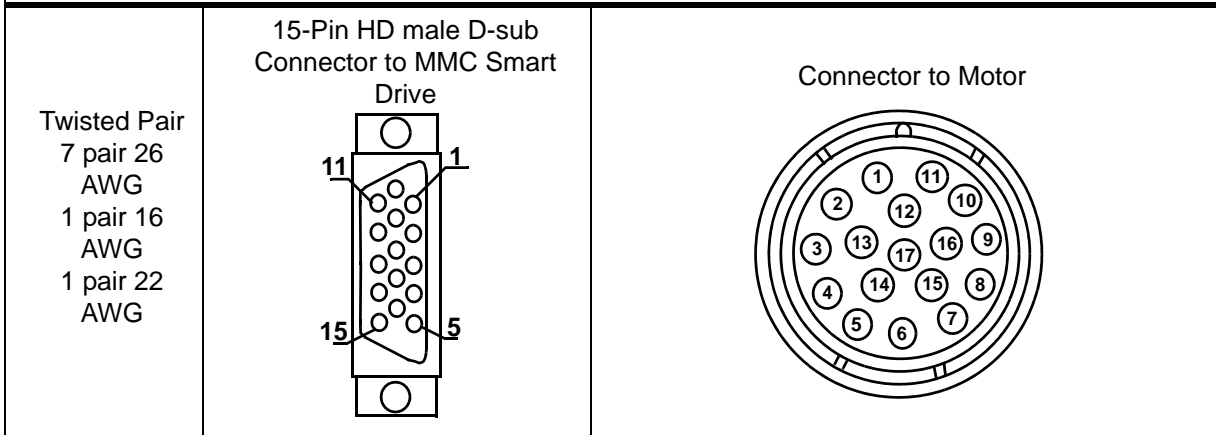
Figure 7-4: Aux Feedback Port Breakout Board Dimensions




DANAHER MOTION PART NUMBER	DANAHER MOTION SHORT DESCRIPTION
M.1302.6970	BKOUT BD,F1/F2,MMC-SD DR MT

Table 7-9: Aux Feedback Port ENDAT/BiSS to AKM/DDR Motor Cable

Part Numbers:
 1 M (3.3 ft): M.1302.0809 3 M (9.8 ft): M.1302.0810 6 M (19.7 ft): M.1302.0811
 9 M (29.5 ft): M.1302.0812 15 M (49.2 ft): M.1302.0813 30 M (98.4 ft): M.1302.0814



Wire Color	Pin Number	Signal Type	Pin Number	Jumper Connections	Signal Type
Yellow	1	COS	9		B+
White/Yellow	2	COS/	1		B-
Blue	3	SIN	11		A+
White/Blue	4	SIN/	3		A-
Black	5	DATA+	5		DATA
White/Black	10	DATA-	13		DATA/
Violet	12	CLOCK+	8		CLOCK
White/Violet	13	CLOCK-	15		CLOCK/
Red	N/U	N/A	12		UnSENSE VCC
White/Red	N/U	N/A	10		UnSENSE COM
Green	11	TEMPERATUR	7		THERMAL
White/Green	N/U	N/A	14		THERMAL
Orange	N/U	N/A	N/U		N/A
White/Orange	N/U	N/A	N/U		N/A
Brown	7	9 VDC	N/U		N/A
White/Brown	N/U	N/A	N/U		N/A
Gray	14	+5 VDC	4		5VDC
White/Gray	6	COM	2	GMD	
N/C	9	N/A	6	N/C	
N/C	15	N/A	16	N/C	
N/C	8	N/A	17	N/C	

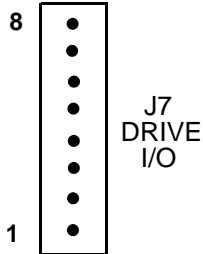
7.1.7 Drive I/O and I/O Power Ports

The 8-pin plugable spring-terminal Drive I/O Port connector (labeled "J7 DRIVE I/O" on the front of the Drive) in combination with the 6-pin plugable spring-terminal I/O Power Port connector (labeled "J6 I/O POWER" on the front of the Drive) provide connection between user I/O devices and the Drive. The Drive I/O port provides 4 source-only, 50ma, short-circuit and over-current protected outputs (described in detail in [section 7.1.8 on page 167](#)), and 4 sink or source (selectable in two groups of two) inputs (described in detail in [section 7.1.8 on page 167](#)). The I/O Power Port supplies power to the Drive I/O Port.

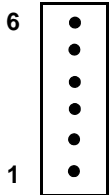
- Pin descriptions for the Drive I/O Port are provided in [Table 7-10](#), and for the I/O Power Port in [Table 7-11](#).
- Pin assignments for the Drive I/O Port are provided in [Table 7-12](#), and for the I/O Power Port in [Table 7-13](#).
- The available Drive I/O Port and I/O Power Port Accessories are described in [Table 7-14](#).
- The Drive I/O is discussed in more detail in [section 7.1.8 on page 167](#).

Table 7-10: Drive I/O Port Pin Descriptions

Function	Notes	Pin
DC Outputs 1-4	Nominal 24 Vdc Outputs capable of sourcing up to 50 ma.	5,6,7,8
DC Inputs 5-8	Nominal 24 Vdc sourcing/sinking Inputs	1,2,3,4

Table 7-11: Drive I/O Port Pin Assignments			
Pin	Signal	In/Out	Connector Pinout
1	DC Input 8	In	8-Pin plugable Screw Terminal Connector 
2	DC Input 7 (Data Capture input for J8 Aux Feedback connector)	In	
3	DC Input 6	In	
4	DC Input 5 (Data Capture input for J3 SFD Feedback connector)	In	
5	DC Output 4	Out	
6	DC Output 3	Out	
7	DC Output 2	Out	
8	DC Output 1	Out	

Function	Notes	Pin
I/O 24V Power	Nominal 24 Vdc to power Drive I/O	3
I/O 24V Common	I/O 24V common	2
DC Inputs 5 and 6 Sink/source	This pin determines whether Drive I/O inputs 5 & 6 are sourcing (this pin connected to 24 Vdc Common) or sinking (this pin connected to 24 Vdc)	6
DC Inputs 7 and 8 Sink/source	This pin determines whether Drive I/O inputs 7 & 8 are sourcing (this pin connected to 24 Vdc Common) or sinking (this pin connected to 24 Vdc)	5
Chassis Ground	This pin should be connected to Chassis Ground	1

Pin	Signal	In/Out	Connector Pinout
1	Chassis Ground	In	6-Pin pluggable Screw Terminal Connector 
2	Drive I/O 24 Vdc Common	In	
3	Drive I/O 24 Vdc	In	
4	N/C	N/A	
5	Input 7&8 Sink/Source	In	
6	Input 5&6 Sink/Source	In	

Description	Part Number
6-pin spring-contact pluggable mating connector for the I/O Power Port (J6)	M.1302.7662
8-pin spring-contact pluggable mating for connector for the Drive I/O Port (J7)	M.1302.7627

7.1.8 Drive I/O Port Details

There are four DC Inputs and four DC Outputs available for interfacing to various devices. This section explains these Inputs/Outputs in detail.

7.1.8.1 Drive I/O Port Outputs

The Drive I/O Port provides 4 source-only 24 Vdc outputs. For sourcing outputs, one side of the load is connected to the Output pin on the Drive I/O connector, and the other side of the load is connected to 24 Vdc Common.

These outputs get their power from Pin 3 of the I/O Power connector. Each of the 4 outputs on the Drive I/O connector is a solid state switch rated at 50 ma, and is short-circuit and over-current protected. In addition, each output is protected with internal clamping diodes. Without clamping, high voltage transients (kickback) from inductive loads might damage the module. For safety reasons, all outputs turn off (no current flow) when a the user program (Ladder) is not running (Scan Loss), or communications to the Drive is lost.

7.1.8.2 Drive I/O Port Inputs

The Drive I/O Port also provides 4 sink/source 24 Vdc inputs.

To configure an Input as Sinking, the Sink/Source select pin (pin 6 for Inputs 5 and 6, pin 5 for inputs 7 and 8), must be connected to 24 Vdc. When configured as Sinking, one side of the input device is connected to the Input pin on the Drive I/O Port connector, and the other side of the input device must be connected to 24 Vdc Common.

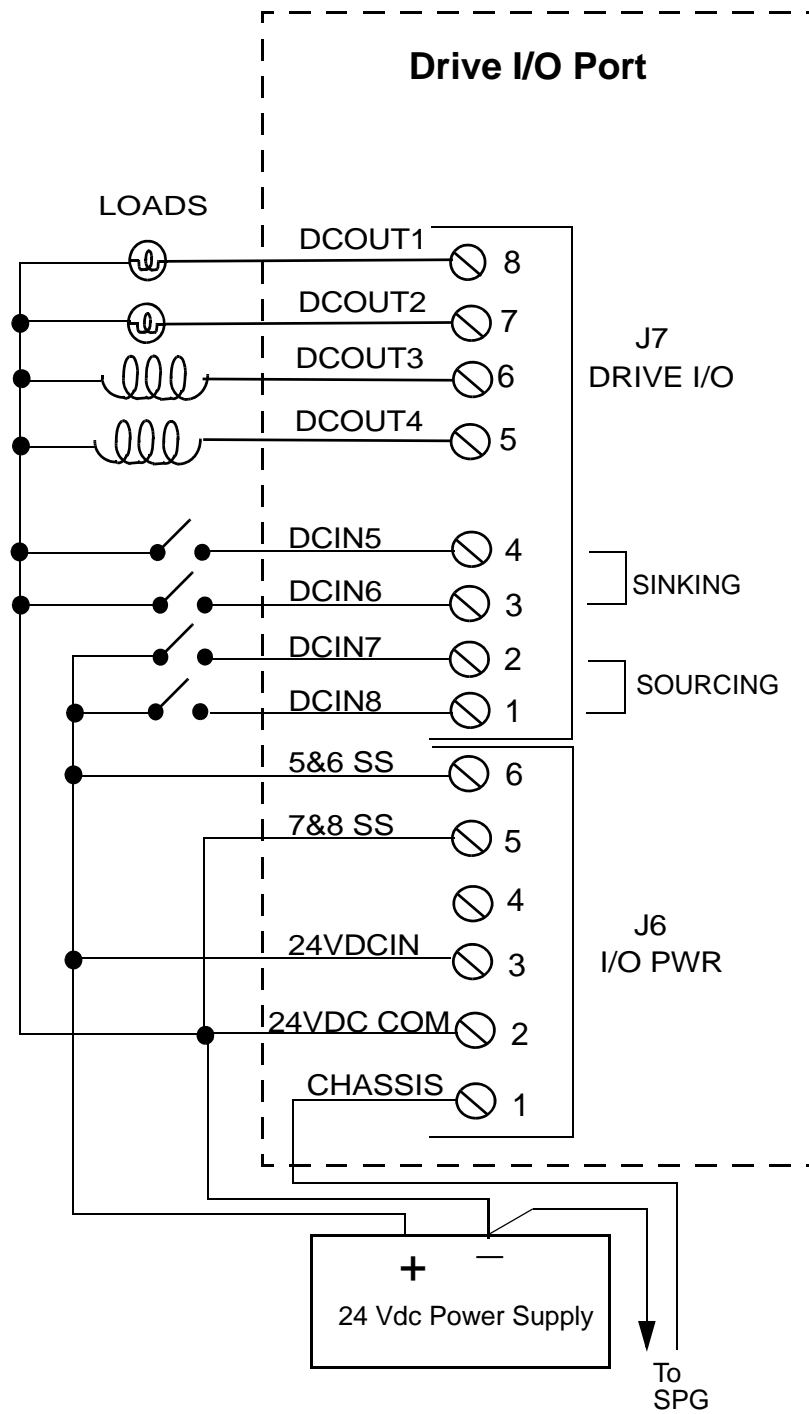
To configure an Input as Sourcing, the Sink/Source select pin (pin 6 for Inputs 5 and 6, pin 5 for inputs 7 and 8), must be connected to 24 Vdc Common. When configured as Sourcing, one side of the input device is connected to the Input pin on the Drive I/O Port connector, and the other side of the input device must be connected to 24 Vdc.

7.1.8.3 Drive I/O Port Wiring Example

An example of wiring the Drive I/O is shown in [See Figure 7-5 on page 168](#).

- Since the Outputs are sourcing, one side of the output device is connected to the Output pin on the Drive I/O Port connector, and the other side is connected to 24 Vdc Common.
- The Sink/Source select pin for Inputs 5 and 6 on the I/O Power Port connector is connected to 24 Vdc, making Drive Inputs 5 and 6 Sinking. In this configuration, one side of the input device is connected to the Input pin on the Drive I/O Port connector, and the other side of the input device is connected to 24 Vdc Common.
- The Sink/Source select pin for inputs 7 and 8 on the I/O Power Port connector is connected to 24 Vdc Common, making Drive Inputs 7 and 8 Sourcing. In this configuration, one side of the input device is connected to the Input pin on the Drive I/O Port connector, and the other side of the input device is connected to 24 Vdc.

Figure 7-5: Connecting Devices to the Drive I/O Port



7.2 Specifications - S200-DLS Drive

The S200-DLS consists of a Base Unit with an S200 Digital Link Option Card installed. The combination of the two components is the S200-DLS Drive. The Base Unit is described in detail in Kollmorgen's S200 Base Unit Reference Manual, P/N M-SM-200-01, which can be found at http://www.kollmorgen.com/website/com/eng/products/drives/ac_servo_drives/s200_manuals.php. Please refer to the S200 Base Unit Reference Manual for Base Unit Specifications, Mounting information, Wiring information, etc. The Base Unit has the same Part Number as the Digital Link version, except that the -DLS is replaced with -VTS. For example, a S20360-DLS consists of an S20360-VTS Base Unit and an S200 Digital Link Option Card.

Any data contained in this manual takes precedence over conflicting data found in the Base Unit manual.

Part Numbers	
S20360-DLS	Output Current = 3A RMS continuous
S20660-DLS	Output Current = 6A RMS continuous
S21260-DLS	Output Current = 12A RMS continuous
S22460-DLS	Output Current = 24A RMS continuous
Drive I/O Port DC Inputs	
Configuration	<ul style="list-style-type: none"> • 4 optically isolated 24V DC inputs • Active high • Sink or source
Guaranteed On	15 VDC
Guaranteed Off	5 VDC
Time delay on	1 ms max.
Time delay off	1 ms max.
Input voltage	Nominal 24 VDC, maximum 30 VDC

Drive I/O Port DC Outputs	
Configuration	<ul style="list-style-type: none"> • 4 optically isolated 24V DC outputs • Active high • Current sourcing only (current into load) • Short circuit and overload protected
Maximum current	50mA per output
Voltage range	24VDC +15%-10%
Time delay on for resistive loads	50 µsec. max
Time delay off for resistive loads	50 µsec. max
Leakage current in off state	0.5 mA max
Digital Link In/Out Ports	
“In” port	Sends and receives high speed data to and from connected MMC-SD’s “Out” port.
“Out” port	Sends and receives high speed data to and from connected MMC-SD’s “In” port.
Cable Type	Shielded, Straight Pinned, CAT5 or better (CAT5e, CAT6, etc.)
Maximum Cable Length	30 m (98.4 ft)
Conformity	
CE Marked Note: Only units Rev 1 or higher are CE Marked.	Conforms to Low Voltage Directive 73/23/EEC (amended by 93/68/EEC) and EMC Directive 89/336/EEC (amended by 92/31/EEC and 93/68/EEC). Conformance is in accordance with the following standards: EN 50178 and EN61800-3
UL and C/UL Recognized	E233454
RoHs	The S200-DLS Drives are not RoHs compliant

8 Cables and Connections to External Devices

8.1 Flex Cable Installation Guidelines

Follow these guidelines for any flexing cable application:

- Cable should be hung suspended for 48 hours to develop its most natural “set* and lay” prior to installation
- A cable should be installed with, not against, its natural set
- Using strain relief fittings at both ends of the cable will reduce conductor breakage at the flex points
- If there is any kink in a cable after installation, it will always remain and eventually cause a cable failure
- After installation, the most critical factors in the cable are the minimum bend radius and the reel tension

* Note: The natural set occurs during the manufacturing of the cable. The cable is cured in one direction on the reel with a notable difference in its ability to be flexed one way versus the other.

When using specially designed flex cables, the following five criteria must be considered:

- Bending Radius
- Cable Tension
- Operating Speed
- Temperature
- Ampacity

Bending Radius and Cable Tension are discussed in the following sections.

8.1.1 Bending Radius

The following guidelines recommended by the ICEA standards are intended to optimize cable life:

- Minimum Bend Radius (Shielded Feedback Cables) = 12 times the Cable Diameter
- Minimum Bend Radius (Shielded Power Cables) = 12 times the Cable Diameter

Reduced bending radii result in reduced cable life due to increased stress on the copper conductors and overall distortion of the cable. Therefore, reduced radii should only be considered for applications in which other factors, such as reduced cable tension, lower operating speed, and ambient temperature are more favorable to cable life, or where the mechanical limitations of the installation do not allow the optimum radius.

Doubling the minimum bending radius for reeling applications can triple cable life at the maximum recommended tension. Therefore, the largest possible bending radius should be used to increase cable life.

8.1.2 Cable Tension

Cable tension plays an extremely important role in determining cable life in reeling. The copper conductors are the principle strength member in flexible cable constructions. Even if strain relief fittings are used on the cable ends, most of the tension will still be supported by the copper conductors.

The effects of tension on a cable are dependent upon the pounds per cross-sectional area of the copper conductors. Larger AWG wires and/or more conductors can handle more tension than smaller AWG wires and/or fewer conductors.

8.2 Flex Cable Installation

Cables should be fixed on both ends to relieve them of tensile loads and prevent any loads from being applied to the molded connectors. At a minimum, the cables have to be fixed on the moving end of the track. A distance of 3 to 6 inches from the track to the fixation point is recommended (See [Figure 8-1](#)).

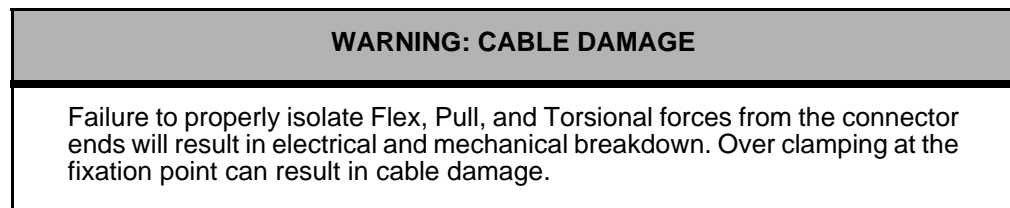
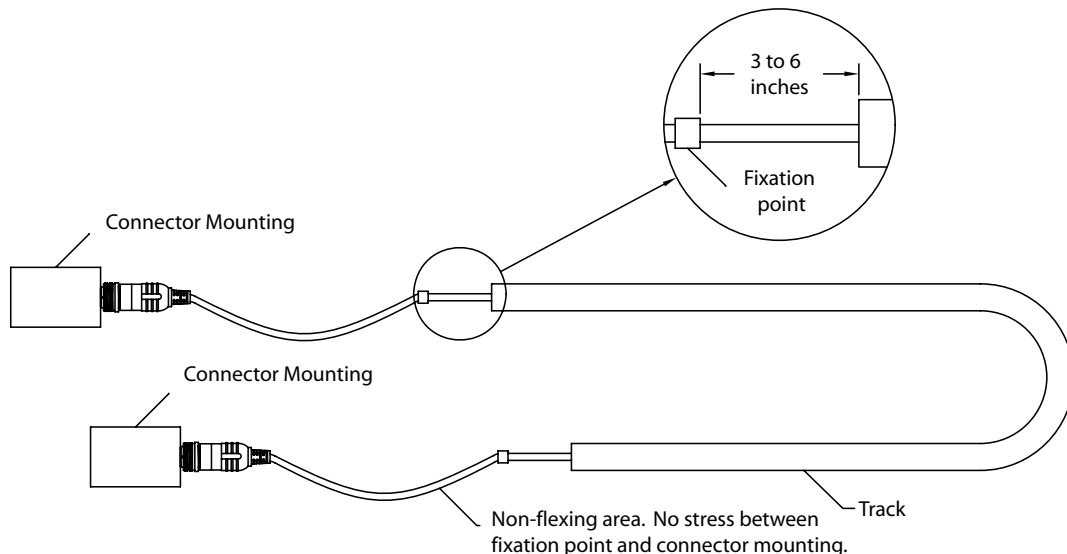


Figure 8-1: Flex Cable Installation



Observe the following precautions when installing flex cables:

- The cable must be able to move freely in the track
- The cable must be able to move in the radius section of the track. This must be checked in the track's fully extended position.

- When cables of different diameters are installed, the use of vertical separators or horizontal shelving is recommended. Cables of similar diameters can be put in the same compartment.
- Cables should never be put on top of one another in high velocity or high cycle applications.
- The cable's weight should be distributed symmetrically over the chain width.

8.3 Motor Power/Fan/Brake Cable Pin Assignments

Table 8-1: LSM/MSM Motor Power Connector Flying Lead Cables

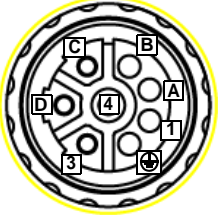
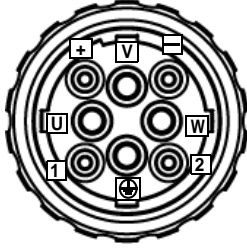
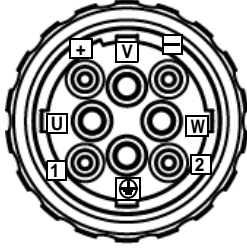


			Connector Pinout		
					
Wire Color	Wire Number	Signal Type	Size 1 Power Connector (Kit No. M.1302.0479)	Size 1.5.1 Power Connector (Kit No. M.1302.1998)	Size 1.5.2 Power Connector (Kit No. M.1302.2354)
Black (1)	1U2	Out	1	U	U
Black (2)	1V2	Out	3	V	V
Black (3)	1W2	Out	4	W	W
Green/ Yellow	PE	Ground	2		
Black (5)	Brake+	Out	A	+	+
Black (6)	Brake-	Out	B	-	-

Table 8-2: LSM/MSM Fan Motor Flying Lead Cable


			Connector Pinout
			
Wire Color	Wire Number	Signal Type	Pin
Brown	U	Out	1
Black	N	Out	2
Green/Yellow	PE	Ground	3

Table 8-3: AKM/DDR Motor Power Flying Lead Cables

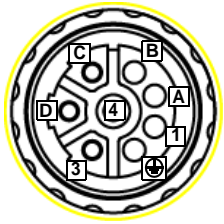
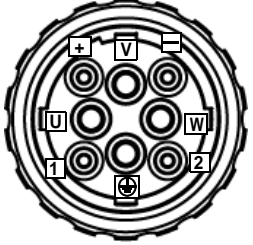
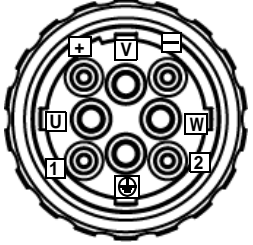


			Connector Pinout		
					
Wire Color	Wire Number	Signal Type	Size 1 Power Connector (Kit No. M.1302.0479)	Size 1.5.1 Power Connector (Kit No. M.1302.1998)	Size 1.5.2 Power Connector (Kit No. M.1302.2354)
Black (1)	U	Out	1	U	U
Black (2)	V	Out	4	V	V
Black (3)	W	Out	3	W	W
Green/ Yellow	PE	Ground	2		
Black (5)	Brake+	Out	A	+	+
White (6)	Brake-	Out	B	-	-

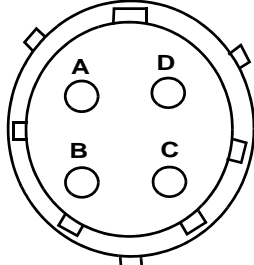

Table 8-4: FSM Motor Power Flying Lead Cable				
				
		Drive Lower Screw Terminal	Connector End to Motor	
Wire Color	Terminal	Signal Type	Pin Number	Signal Type
Brown	U	Out	A	Out
Black	V	Out	B	Out
Blue	W	Out	C	Out
Green/Yellow		Ground	D	Ground

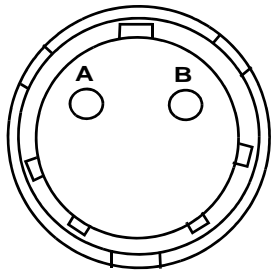
Table 8-5: FSM Motor Brake Flying Lead Cable	
	
Pin Number	Signal Type
A	B+
B	B-

Table 8-6: YSM Motor Power and Brake Flying Lead Cable

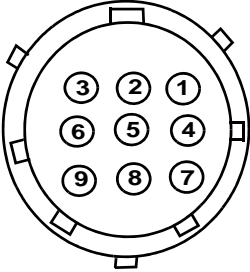
				
	Drive Lower Screw Terminal		Connector End to Motor	
Wire Color	Terminal	Signal Type	Pin Number	Signal Type
Brown	U	Out	1	Out
Black	V	Out	2	Out
Blue	W	Out	3	Out
N/A	N/U	N/A	4 (N/U)	N/A
Green/Yellow	⊕	Ground	5	Ground
N/A	N/U	N/A	6 (N/U)	N/A
N/A	N/U	N/A	8 (N/U)	N/A
			7	B+
			9	B-

Table 8-7: YSM Motor Brake Flying Lead Cable

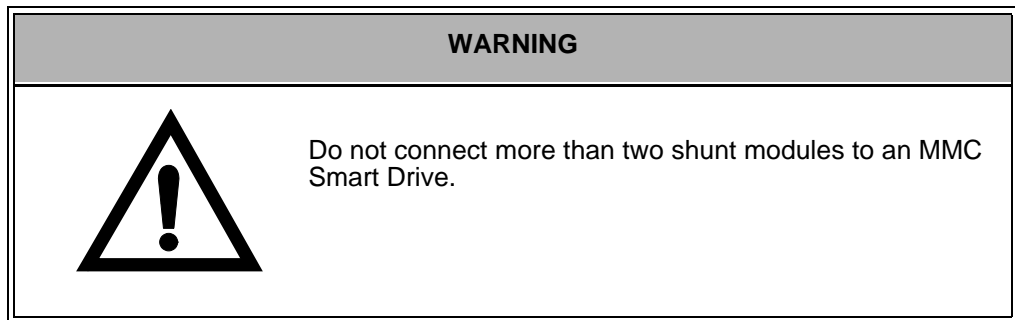
Pin Number	Signal Type
7	B+
9	B-

8.4 Connecting Shunt Modules

Use shielded, high temperature 75° C (167° F), 600V, 2.5-4.0 mm² (12-14 AWG), 3.05 m (10 ft) maximum, copper wire. Follow one of the methods given below to reduce the effects of EMI noise:

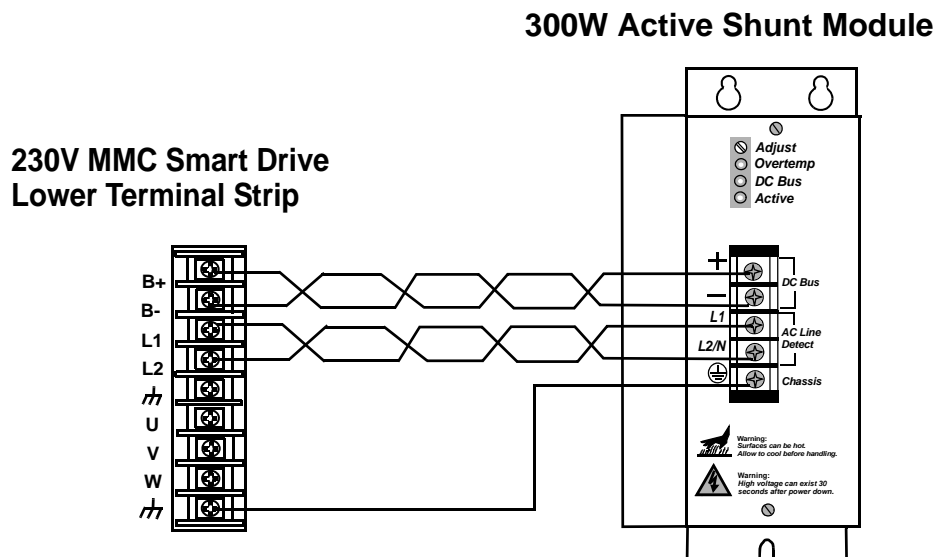
- Install wires using twisted pairs (two turns per foot minimum), as shown in the figure above. Keep unshielded wires as short as possible.
- Use shielded, twisted cable (ground shield at shunt and drive).
- Use shielded metal conduit (ground conduit at shunt and drive).

When two shunt modules are connected in parallel, the shunt capacity is doubled.



8.4.1 Connecting the 230V MMC Smart Drive to 300 W Shunt Module

Figure 8-2: Wiring 230V MMC Smart Drive to 300W Active Shunt Module



8.4.2 Connecting the 460V MMC Smart Drive to Kollmorgen Shunt Modules

Figure 8-3: Wiring 460V MMC Smart Drive to 450 Watt, 130Ω Shunt Module / 700 Watt, 95Ω Shunt Module / 1400 Watt, 50Ω Shunt Module

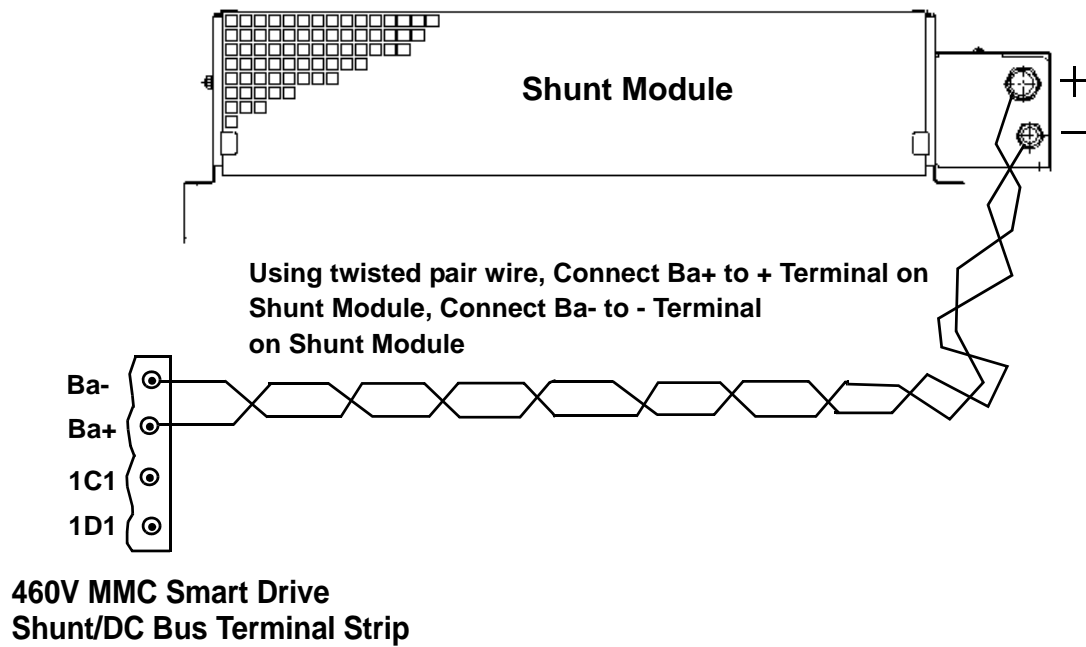
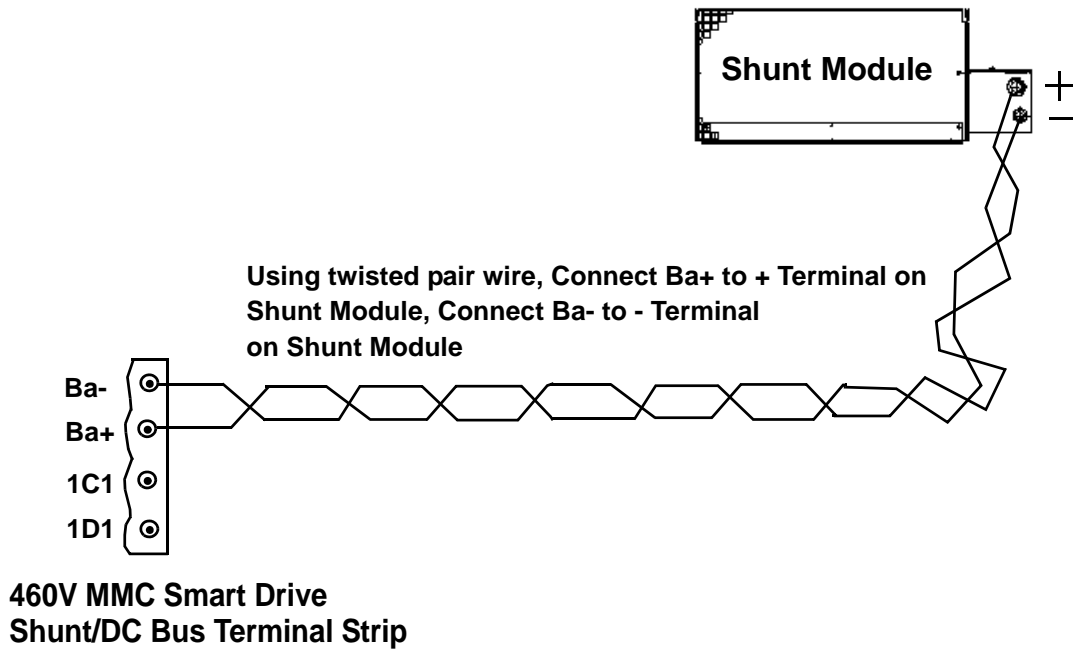
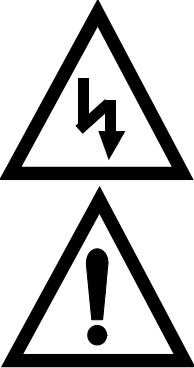


Figure 8-4: Wiring 460V MMC Smart Drive to 2800 Watt, 25Ω Shunt Module / 3900 Watt, 18Ω Shunt Module



9 Maintenance and Troubleshooting

9.1 Maintenance

WARNING	
	<p>Disconnect input power before touching cables or connections.</p> <p>DC bus capacitors may retain hazardous voltages after input power has been removed.</p> <p>Before working on the drive, measure the DC bus voltage to verify it has reached a safe level.</p> <p>Failure to observe this precaution could result in severe bodily injury or loss of life.</p>

- Remove superficial dust and dirt from the drive.
- Check cable insulation and connections.
- Clean exterior surfaces and airflow vents using an OSHA approved nozzle that provides compressed air under low pressure of less than 20 kPa (30 psi).
- Visually check for cable damage. Replace all damaged cables.
- Inspect D-shell connectors for proper seating and signal continuity end-to-end.

9.2 Troubleshooting

9.2.1 General Troubleshooting

Refer to [Table 9-1](#) for general troubleshooting information.

Table 9-1: General Troubleshooting Symptoms, Causes, Remedies		
Symptom	Possible Cause	Remedy
Power (P) indicator not ON	No 24VDC input power.	Verify 24 VDC power is applied to the drive.
	Internal power supply malfunction.	Contact your Kollmorgen representative.
Motor jumps when first enabled	Motor wiring error.	Check motor feedback and power wiring.
	Incorrect motor chosen.	Verify the proper motor is selected.
	Incorrect or faulty encoder	Replace the encoder with correct and/or functional encoder.
I/O not working correctly	I/O power supply disconnected.	Verify connections and I/O power source.

9.2.2 Power-On Diagnostics

When the drive is powered up, it tests itself and reports the results of the tests in the form of LED signals.

9.2.2.1 Power LED

If the Power (P) LED does not go on, or goes off during operation of the system, check that 24 VDC power is still connected to the drive. Please note that the Power (P) LED is not available on the S200-DLS Drive.

9.2.2.2 Diagnostic LEDs

The Diagnostic LED (D1) lights up briefly while diagnostic tests are running and then goes off. If the Diagnostic LED (D1) remains on, the drive has failed one of its diagnostic tests. Follow these steps:

1. Turn off power to the drive system and to the application.
2. Perform any necessary maintenance to the drive.
3. Check the I/O wiring and the devices the system is connected to. There may be a short or other problem other than the drive. Correct these problems.

4. Turn on power to check diagnostics again.

NOTE
<p>Power-On diagnostics are run only when the system is powered up. If a drive fails during power-up, the Diagnostic LED (D1) light remains on. If you suspect that a drive is defective, cycle power to run diagnostics again.</p>

9.2.3 Run-Time Diagnostics

While the MMC Smart Drive is running, other tests are performed on a regular basis with their results reported through the Diagnostic LED (D1) and the Status LED (labeled "STATUS", only available on the S200-DLS Drive). The Diagnostic LED is covered in detail in [Section 9.2.3.1](#). The Status LED is covered in detail in [section 9.2.3.1 on page 185](#).

9.2.3.1 Troubleshooting with the Diagnostic LED (D1)

This section pertains to the Diagnostic LED labeled "D1" located on the front of the 230V Smart Drive, the 460V Smart Drive, and the S200-DLS Drive. The S200-DLS Drive also has a Status LED, labeled "STATUS", which is covered in [section 9.2.3.2 on page 192](#).

When a Warning or Fault is detected, the Diagnostic LED (D1) located on the face of the drive will flash a one-digit Warning Code or a two-digit Fault Code. The LED will continue to flash the Code until the Warning or Fault is eliminated.

For example, if there is a long pause-flash-pause-flash-flash-long pause, the Code is 12.

Warning conditions give the user an indication of a potential problem, but do not disable the drive. Whenever a Warning condition is detected, the drive generates a single-digit Warning Code. The user can detect a Warning condition in three ways:

- by visually observing the "D1" LED on the front of the Drive
- by examining the Drive Maintenance page in PiCPro under "Faults and Warnings"
- by reading the Warning Code using READ_SV variable 69 from within the user's Ladder.

Fault conditions give the user an indication of a more serious problem, and disable the Drive. Whenever a Fault condition is detected, the drive generates a two-digit Fault Code.

The Drive Diagnostic Codes are described in [Table 9-2](#).

Table 9-2: Drive Diagnostic LED Codes			
Code	Description	Possible Causes	Possible Remedies
Codes 01 through 06 are Warning Codes, and do not disable the Drive			
01	Drive Heatsink Temp. Warning	Drive heatsink temperature exceeds warning limit	<ul style="list-style-type: none"> • Lower the ambient temperature around the drive.
02	Drive Ambient Temp. Warning	Acceptable ambient temperature limit has been exceeded warning limit	
03	Motor Temp. Warning (available only when the motor contains a thermistor)	Thermistor temperature has exceeded user defined acceptable limit.	<ul style="list-style-type: none"> • Reduce acceleration rates. • Reduce duty cycle (ON/OFF) of commanded motion. • Increase time permitted for motion. • Use larger drive and motor. • Check tuning.
04	Motor Calculated Temp. Warning (available only when the motor does not contain a thermistor).	Calculated motor temperature has exceeded acceptable limit	
05	Overtravel Plus Warning	The Overtravel Plus Fault input is low because the axis has reached the Plus Travel Limit.	Move the axis off the Plus Limit Switch in the negative direction.
06	Overtravel Minus Warning	The Overtravel Minus Fault input is low because the axis has reached the Minus Travel Limit.	Move the axis off the Minus Limit Switch in the positive direction.
Codes 11 and higher are Fault Codes, and disable the Drive			
11	Drive Memory Fault	The drive's non-volatile memory is not functioning properly	Upgrade firmware. Contact Kollmorgen.

Table 9-2: Drive Diagnostic LED Codes (Continued)

Code	Description	Possible Causes	Possible Remedies
12	Drive Bus Over Voltage Fault	Excessive regeneration of power. The motor may regenerate too much peak energy through the drive's power supply. A fault is generated to prevent overload.	Change the deceleration or motion profile. Check shunt connections and where necessary, properly make connections. Reduce the reflected inertia of your mechanical system. Use a larger motor and/or drive.
		Excessive AC input voltage.	Verify input AC voltage is within specifications. Adjust accordingly.
		Output short circuit.	Remove all power and motor connections, and perform a continuity check from the DC bus to the U, V, and W motor outputs. If a continuity exists, check for wire fibers between terminals, contact Kollmorgen
		Motor cabling wires shorted together.	Disconnect motor power cables from the drive. Test the cables for short circuits. Replace cable if necessary.
		Internal motor winding short circuit.	Disconnect motor power cables from the motor. If the motor is difficult to turn by hand, it may need to be replaced. Test winding resistance to confirm short circuit.
		230V motor used with a 460V drive and drive powered at 460V.	Set the drive for operation at 230V and apply 230V power to the drive.
13	Drive PM1 Over Current Fault	Current feedback exceeds the drive over current fault limit.	Adjust the over current fault limit.
		Output short circuit.	Remove all power and motor connections, and perform a continuity check from the DC bus to the U, V, and W motor outputs. If a short exists, check for wire fibers between terminals, contact Kollmorgen
		Motor cabling wires shorted together.	Disconnect motor power cables from the drive. If faults stop, replace cable.
		Internal motor winding short circuit.	Disconnect motor power cables from the motor. If the motor is difficult to turn by hand, it may need to be replaced.

Table 9-2: Drive Diagnostic LED Codes (Continued)			
Code	Description	Possible Causes	Possible Remedies
14	Drive Over Power Fault	Drive current and voltage output, in combination with the heatsink temperature indicate that the power output required by the drive would damage the power section.	Verify ambient temperature is not too high. Operate within the continuous power rating. Reduce acceleration rates. Check for mechanical load problems and adjust as necessary. Resize the application and apply components accordingly.
15	Motor Temperature Fault	Motor thermostat trips due to high motor ambient temperature	Operate within (not above) the continuous torque rating for the ambient temperature (40°C maximum). Lower ambient temperature, increase motor cooling. Check that motor is properly sized for the application. If necessary, resize the motor.
		Motor thermostat trips due to excessive current	Reduce acceleration rates. Increase time permitted for motion. Use larger drive and motor. Reduce duty cycle (ON/OFF) of commanded motion. Check tuning.
		Motor thermostat trips due to motor wiring error.	Check motor wiring.
		Motor thermostat trips due to incorrect motor selection.	Verify the proper motor has been selected.
16	Continuous Current Fault	Current exceeds the continuous motor current rating for an extended period of time.	Change motor and or drive to be compatible with load requirements. Check tuning.
17	Drive Heatsink Temperature Fault	Drive heatsink temperature exceeds drive heatsink fault limit	Let the drive cool down and/or reduce the load.
22	Drive F1 Feedback Fault	Error is detected in the motor feedback	Verify motor selection is correct. Check to be sure the correct encoder is attached. Verify encoder wiring is correct. Use shielded cables with twisted pair wires. Route the encoder feedback cable away from potential noise sources. Check ground connections.

Table 9-2: Drive Diagnostic LED Codes (Continued)

Code	Description	Possible Causes	Possible Remedies
23	Drive Ambient Temp. Fault	Drive ambient temperature exceeds the drive ambient temperature fault limit	Operate within (not above) the continuous rating for the ambient temperature. Lower ambient temperature, increase cabinet cooling.
24	Motor Calculated Temp. Fault	Motor calculated temperature exceeds the motor calculated temperature fault limit.	Check the machine for excessive loads. Motor may be undersized for the application.
25	Drive Timing Fault	Timing error is detected in the execution of the control algorithms performed by the drive's digital signal processor.	Contact Kollmorgen.
26	Drive Interface Fault	Communication error is detected in the transmission of information between the drive's digital signal processor and the drive's power section.	Contact Kollmorgen.
27	User Set Fault	PiCPro Set User Fault command selected.	The PiCPro Set User Fault command was selected or the Control Panel mode was activated or deactivated while the drive was enabled.
31	Drive F1 Communication Fault	Communication error is detected in the transmission of information between the drive and a high resolution or multi-turn absolute feedback device.	Check encoder line and make sure the correct encoder is attached. Verify encoder wiring is correct. Use shielded cables with twisted pair wires. Route the encoder feedback cable away from potential noise sources. Check ground connections. Verify motor selection is correct.
		Bad encoder.	Replace motor and encoder.
32	Over Speed Fault	User specified motor speed has been exceeded.	Check cables for noise. Check tuning.
33	Over Current Fault	User-Specified average current level has been exceeded.	Change to a less restrictive setting. Reduce the load.
34	Drive Communication Fault	Communication error occurs while drive control is being performed using the PiCPro Control Panel tools.	Do not disconnect the PiCPro cable while operating in Control Panel Mode.

Table 9-2: Drive Diagnostic LED Codes (Continued)			
Code	Description	Possible Causes	Possible Remedies
35	Drive Power Module Fault	The drive's power section detects a fault condition.	Verify AC power is applied to drive. Contact Kollmorgen.
36	Drive Setup Data Fault	The configuration data has been corrupted.	Re-download Drive Setup Data.
41	Drive Relay Fault	The drive's power section relay did not function properly during power-up.	Check the drive system connections. Adjust as necessary. Contact Kollmorgen.
42	Drive PM2 Over Current Fault	Current feedback exceeds the drive over current fault limit.	Adjust the over current fault limit.
		Output short circuit.	Remove all power and motor connections, and perform a continuity check from the DC bus to the U, V, and W motor outputs. If a continuity exists, check for wire fibers between terminals, contact Kollmorgen.
		Motor cabling wires shorted together.	Disconnect motor power cables from the drive. If faults stop, replace cable.
		Internal motor winding short circuit.	Disconnect motor power cables from the motor. If the motor is difficult to turn by hand, it may need to be replaced.
43	Drive PM Over Temperature Fault	Drive power module temperature exceeds the drive power module temperature fault limit	Check to be sure that the drive is being operated within the continuous power rating. Check for adequate enclosure ventilation. Ensure cooling air flow is adequate in space around the drive. Check for clogged vents or defective fan. Contact Kollmorgen.
44	Motor Ground Fault	Ground fault has occurred.	Make sure motor ground connections are correct. Replace defective motor ground wires. Check for internal motor winding short circuits.
45	Drive AC Input Over Voltage Fault	Incoming AC voltage is too high.	Verify input VAC is within specifications.

Table 9-2: Drive Diagnostic LED Codes (Continued)

Code	Description	Possible Causes	Possible Remedies
46	Overtravel Plus Fault	Overtravel Plus Fault input is off and Drive Ignore Plus Travel Limit is off.	Overtravel Plus Fault status can be monitored using READ_SV variable 68 AND (16#400 0000). Fault input write a 0 to WRITE_SV variable 86. Use DRSETFLT to reset fault indications. To override the Overtravel Plus Fault input write a 1 to WRITE_SV variable 86, Ignore Plus Travel Limit. To reactivate checking of the Overtravel Plus input write a 1 to WRITE_SV variable 86, Ignore Plus Travel Limit. To reactivate checking of the Overtravel Plus Fault input write a 0 to WRITE_SV variable 86.
47	Overtravel Minus Fault	This fault is set when the Overtravel Minus Fault input is off and Drive Ignore Minus Travel Limit is off.	Overtravel Minus Fault status can be monitored using READ_SV variable 68 AND (16#800 0000). Use DRSETFLT to reset fault indications. To override the Overtravel Minus Fault input write a 1 to WRITE_SV variable 87, Ignore Minus Travel Limit. To reactivate checking of the Overtravel Minus Fault input write a 0 to WRITE_SV variable 87.
51	Digital Link Communication Error	This fault is set when two consecutive corrupt Digital Link messages are detected or no Digital Link messages are received within 250 microseconds.	Digital Link Communication Error status can be monitored using READ_SV variable 68 AND (16#1000 0000). This fault requires that the user servo setup function and DSTRTSRV be executed prior to executing DRSETFLT to reset the fault indication.
52	Invalid Switch Setting Fault	This fault is set when the drive address switch setting is set to 0 or greater than 64 or its setting is changed while the Digital Link is operating in cyclic communications mode.	Invalid Switch Setting Fault status can be monitored using READ_SV variable 68 AND (16#2000 0000). Use DRSETFLT to reset fault indications. Note: Digital Link initialization must be performed before this fault can be reset.
53	Cannot Determine Drive Type	<ul style="list-style-type: none"> • Regulator board was initialized when installed on a different Power Board. • Flash Data Invalid or Not Readable, 	<ul style="list-style-type: none"> • Re-initialize Drive • Drive damaged - consult factory

Code	Description	Possible Causes	Possible Remedies
77	Drive Not Ready	Power applied to an uninitialized drive.	Initialize and configure the drive using PiCPro.

9.2.3.2 Troubleshooting using the Status LED (STATUS)

This section pertains to the Status LED labeled "STATUS" located on the front of the S200-DLS Drive. The 230V Smart Drive, the 460V Smart Drive, and the S200-DLS Drive also have a Diagnostic LED, labeled "D1", which is covered in [section 9.2.3.1 on page 185](#).

Fault codes for the S200-DLS Drive are described in [Table 9-3](#).

Fault Code	Fault	Possible Causes
ON	No faults and power stage Enabled	Normal Operation
OFF	control power not applied insufficient control power applied	Loose or open circuit wiring of control power input. Low input voltage to control power supply.
Fast Blink	No faults and power stage Disabled	Hardware or Software Enable inactive. To enable the Drive, apply hardware enable and set software enable.
2	Motor Over Temp • motor temperature exceeds allowed limit	High ambient temperature at motor. Insufficient motor heat sinking from motor mounting. Operating above the motor's continuous current rating. Motor temperature sensor failure or not connected.
3	Drive Over/Under Temp • Temperature of drive heatsink/chassis is outside of allowed limits	• High or low drive ambient temperature. • Restriction of cooling air due to insufficient space around unit. • Operating above the drive's continuous current rating.

Table 9-3: Drive Status LED Fault Codes (Continued)

Fault Code	Fault	Possible Causes
4	Drive I*t Too High <ul style="list-style-type: none"> • The product of the drives output current multiplied by time has exceeded allowed limits. • If current foldback is enabled the drive peak output current automatically reduces to 0.67% of DIpeak. If foldback is not enabled, the drive will fault. 	<ul style="list-style-type: none"> • Mechanically-jammed motor. • Motion profile acceleration requires peak current for too long of a time duration. • Machine load on the motor increased by friction. • Wiring problem between drive and motor yielding improper motion.Motor commutation error. • Drive under-sized for application, friction or load.
5	Motor I*I*t Too High <ul style="list-style-type: none"> • Motor current amplitude squared multiplied by time has exceed allowed limits 	<ul style="list-style-type: none"> • Mechanically-jammed motor. • Motion profile acceleration requires peak current for too long of a time duration. • Machine load on the motor increased by friction. • Motor commutation error. • Motor under-sized for application, friction or load.
6	Optional Battery low <ul style="list-style-type: none"> • Optional fault used to indicate SFD battery supply voltage is low 	<ul style="list-style-type: none"> • Battery low fault enabled and battery is not installed. • SFD Battery backup voltage is low.
7	Bus Over Voltage - Self Re-setting <ul style="list-style-type: none"> • The BUS voltage has exceed the upper threshold limit 	<ul style="list-style-type: none"> • AC Line voltage is too high. • Regenerative energy during deceleration is causing the BUS to rise (possible remedy: add regen resistor).
9	Motor I-I or I-n Short <ul style="list-style-type: none"> • Line-to-Line, Line-to-Neutral or Line-to-PE short on the motor output causing an instantaneous over current. 	<ul style="list-style-type: none"> • Motor power wiring short circuit - line-to-ground /neutral. • Motor cable short line-to-line. • Motor power cable length exceeds the data sheet specification causing excessive motor line-to-earth ground/neutral capacitance. • Internal motor winding short circuit. • Motor L too small. • KIP set too large.

Table 9-3: Drive Status LED Fault Codes (Continued)		
Fault Code	Fault	Possible Causes
10	Output Over Current	<ul style="list-style-type: none"> • Insufficient motor inductance • KIP or KII improperly set causing excessive output current overshoots.
11	Hall Fault <ul style="list-style-type: none"> • Valid only when drive is set for 6 Step (Hall feedback) operation. 	<ul style="list-style-type: none"> • Invalid configuration. • Motor overspeed. • Invalid hall state. • Invalid hall transition.
12	SFD Configuration Error	<ul style="list-style-type: none"> • SFD UART error during SFD initialization. • Bad motor data check sum. • The drive will attempt to initialize the SFD up to 4 times. If it fails this error is reported.
13	J3 FB +5V Short <ul style="list-style-type: none"> • Excessive current drain on SFD +5 supply output. 	<ul style="list-style-type: none"> • Excessive loading on SFD +5 supply. • Short in the feedback cable on SFD +5 (J3-1) to ground.
14	SFD Motor Data Error <ul style="list-style-type: none"> • Motor data in SFD is outside drive limits or is inconsistent 	<ul style="list-style-type: none"> • Motor and Drive are not compatible. Auto setup calculation yielded a desired parameter value outside valid range. • Incorrect/inconsistent motor data loaded into the SFD.
15	SFD Sensor Failure Internal SFD failure.	Excessive electrical noise in the drive environment causing communications interference.
16	SFD UART Error	Internal SFD failure.
17	SFD Communication Error	<ul style="list-style-type: none"> • Feedback cable not connected at the drive or at the motor. • Feedback cable shield not connected. • Defective feedback cable • Internal SFD failure. • Excessive electrical noise in the drive environment causing communications interference.
18	Option Card Watch Dog Time out	Communication error between option card and main board.

Table 9-3: Drive Status LED Fault Codes (Continued)

Fault Code	Fault	Possible Causes
19	Position Error Too Large	<ul style="list-style-type: none"> • If ExtFaults = Step size over flow then GearOut/GearIn is too large. • If ExtFaults = Position error over flow then the following error (PosErr), has exceeded ± 128 revs. • Check if the motor is stalling or if the commanded speed is higher than the motor can achieve at the present bus voltage.
20	Option Card Fault	<ul style="list-style-type: none"> • If ExtFaults is AuxFBFault, then the AuxFB device is in error. • Check the AuxFB faults: AuxFBEnDatFlt, AuxFBPTCFIt or AuxFBSCDFIt. • Check to make sure that the drive is set up for the correct feedback device and that the device is functioning correctly. If ExtFaults is "No ExtendedFault," then this was a fault induced by the controller, such as SynqLost.

10 Resolver Interface Option Module

The Resolver Interface Option module can be installed in the 230V or 460V Smart Drive. It cannot be installed in an S200-DLS Drive. This section describes the Resolver Interface Option Module in detail.

10.1 Theory of Operation

The Resolver Interface Option Module provides the interface between the resolver and the drive's DSP. It is a tracking system where the rotor is excited with a sine wave. The outputs of the resolver are amplitude modulated by the sine and cosine of the rotor shaft angle. The tracking converter converts the sine and cosine amplitude ratio into a 12 bit number.

The module provides a 4 Vrms 5 kHz sine wave to excite the resolver rotor. The resolver transformer ratio is .5:1 so the stator outputs are 2V RMS with the shaft rotated to the angle of maximum coupling. The sine and cosine rotor outputs are returned to the resolver module's twin instrumentation amplifier inputs to produce a high common mode noise rejection and a high input impedance (220K Ω). The sine and cosine signals are then fed to a resolver to digital converter chip that performs the tracking conversion. The converter has both a serial output and an encoder emulator output. The serial output is read when the drive is powered up to obtain the absolute commutation angle for the motor. Thereafter, it is used as an encoder emulator.

The module is able to detect a loss of feedback by monitoring the sine and cosine signals. If both are near zero at the same time, a loss of feedback error is generated.

10.2 Installing the Resolver Module

1. If the Resolver Module is being installed in a 230V drive, remove the five screws at the corners of the cover and remove the cover. If the Resolver Module is being installed in a 460V drive, turn the 2 locking screws on the front of the drive clockwise and remove the MMC Smart Drive board from the drive chassis.
2. Remove the shunt from the 24-pin DIP socket located on the MMC Smart Drive board (See Figure 10-1 on page 198).
3. If there are not two standoffs already installed on either side of the 24-pin DIP socket on the MMC Smart Drive board, proceed to step 10.
4. If there are nylon standoffs snapped into the Resolver Module, remove and discard them. If there are nylon standoffs included with the Resolver Module, discard them.
5. Remove and save the two nylon screws that are threaded into the standoffs mounted to the MMC Smart Drive board.
6. Position the Resolver Module so the mounting holes align with the standoffs, and the header is aligned with the socket (See Figure 10-2 on page 199).
7. Using even pressure, press the option module into place.
8. Screw the Resolver Module to the standoffs using the screws removed in step 5.
9. Verify that the module is fully seated into the socket and proceed to step 15.
10. If there are standoffs installed in the Resolver Module, proceed to step 12.
11. Install the snap-in standoffs that were included with the Resolver Module into the Resolver Module. From the back of the Resolver Module (the side that has the 24-pin header on it), insert the short (slotted) end of the standoffs into the mounting holes.

12. Position the Resolver Module so the long (locking tab) end of the standoffs line up with the mounting holes on the Drive board, and the header is aligned with the socket (See Figure 10-2 on page 199).
13. Using even pressure, press the option module into place.
14. Verify that the module is fully seated into the socket and the locking tabs on the standoffs are in the locked position.
15. If the Resolver Module was installed in a 230V drive, re-install the cover and five screws removed in step 1. If the Resolver Module was installed in a 460V drive, re-install the MMC Smart Drive board into the chassis and turn the 2 locking screws on the front of the drive counter-clockwise to secure the front panel to the chassis.

Figure 10-1: : Before Shunt Removed and Resolver Module Installed

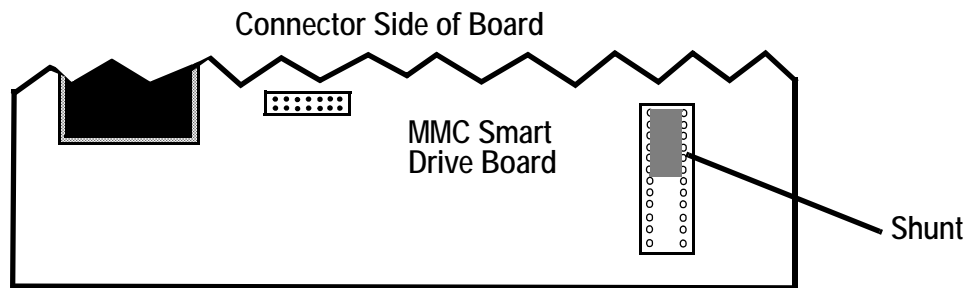
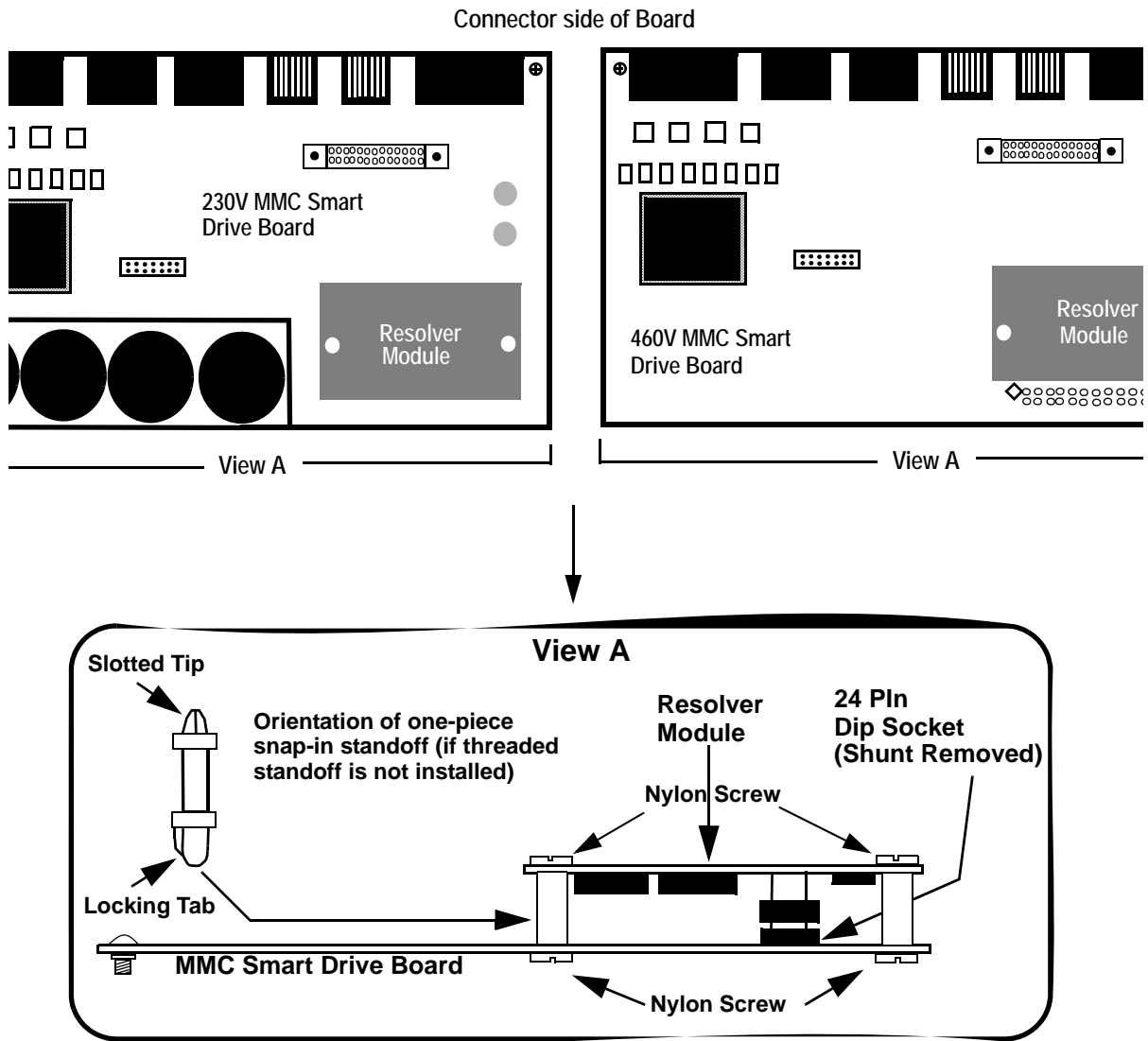


Figure 10-2: : Shunt Removed and Resolver Module Installed



10.3 Specifications

Characteristics	Resolver Interface Option Module Specifications
Part Number	M.1302.4523
Function	Resolver to encoder converter
Part Number	M.1302.4523
Field Side Connector	F1 Feedback Connector
Excitation Frequency	5 kHz
Output Voltage	4 V _{RMS}
Current per Output Channel, max.	28 mA _{RMS}
Resolver Transformer Ratio	0.5:1.0
Resolver Resolution	4096 Feedback Units (FUs) per electrical revolution
Accuracy Over Temperature Range	+ 15 minutes
Electrical Velocity, max.	500 RPS
Cable Length, max.	30 M
Power	Powered from MMC Smart Drive

11 Drive Resident Digital MMC Control

The Drive Resident Digital MMC Control can be installed in the 230V or 460V Smart Drive. It cannot be installed in an S200-DLS Drive. This section describes the Drive Resident Digital MMC Control in detail.

11.1 Introduction

This section contains information for the Drive Resident Digital MMC Control (Digital MMC-Dx). Block I/O information can be found in the Block I/O Modules Manual. Software information can be found in the PiCPro Online Help, the Function/Function Block Reference Guide, ASFB Manuals or on-line.

11.1.1 Overview

The Drive Resident Digital MMC Control offers a complete solution to both machine and motion control in a module that is installed into any Digital Interfaced Smart Drive (MMC-SD-D) except the 230V Narrow Drive (-DN). One Drive Resident Digital MMC Control can control from 1 to 16 drives as follows:

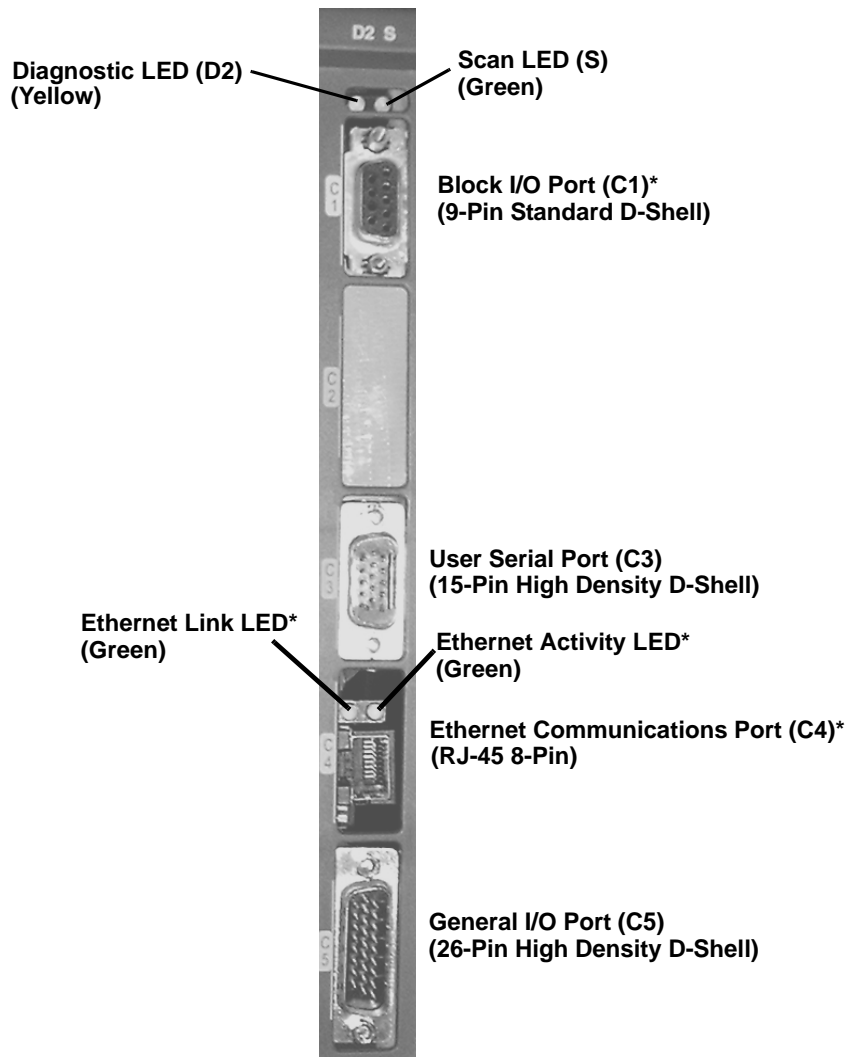
- Digital MMC-D1 (controls one MMC-SD-D)
- Digital MMC- D2 (controls two MMC-SD-D)
- Digital MMC- D4 (controls four MMC-SD-D)
- Digital MMC- D8 (controls eight MMC-SD-D)
- Digital MMC- D16 (controls 16 MMC-SD-D)

PiCPro is used to program the Drive Resident Digital MMC Control. The built-in I/O (eight 24VDC inputs and eight 24VDC outputs) can be expanded using Kollmorgen serially distributed block I/O (not included on the Digital MMC-D1).

11.1.2 Major Components

The Drive Resident Digital MMC Control contains the CPU, a User Serial port, a Block I/O port, an Ethernet port, and a General I/O port consisting of 8 DC inputs and 8 DC outputs.

Figure 11-1: The Drive Resident Digital MMC Control



* The Block I/O Port connector (C1), Ethernet Communications Port connector (C4), Ethernet Link LED, and Ethernet Activity LED are present on the Digital MMC-D1 Control, but are not functional.

11.2 Installing the Drive Resident Digital MMC Control

11.2.1 Installing into a 230V MMC-SD Drive

1. Remove the three screws from the right side of the cover and one screw from the top and bottom of the drive near the front. Remove the cover.
2. Place the cover removed in step 1 on a flat surface, with the blue plastic faceplate down, and the large side cover to the left pointing up.
3. Remove the two screws that hold the .6" by 8" blue filler plate to the back of the faceplate and remove the plate.
4. Locate the 4 screws that secure the top-most printed circuit board into the drive. Remove one of the screws and the associated lock washer, and install one of the four threaded standoffs that were included with the Drive Resident Digital MMC Control (do not use the lock washer). Repeat this process for the other 3 screws, one at a time.
5. Place the Drive Resident Digital MMC Control into the drive, with the connectors facing towards the front of the unit. Align the 20-pin connector on the Drive Resident Digital MMC Control with the 20-pin connector on the drive. Press the Drive Resident Digital MMC Control onto the drive until the 20-pin connector is completely seated and the Drive Resident Digital MMC Control is seated against the threaded standoffs installed in step 4.
6. Fasten the Drive Resident Digital MMC Control onto the threaded standoffs using the lockwashers and screws removed in step 4.
7. Replace the cover using the 4 screws removed in step 1.

11.2.2 Installing into a 460V MMC-SD Drive

1. Turn the two locking screws on the front of the drive clockwise $\frac{1}{4}$ turn and pull the drive control board unit out of the drive.
2. Place the drive control board unit removed in step 1 on a flat surface, with the blue plastic faceplate down, and the drive control board to the left.
3. Remove the two screws that hold the .6" by 8" blue filler plate and remove the plate.
4. Place the drive control board unit on a flat surface so that the control board is facing up, and the blue plastic faceplate is facing away from you.
5. Locate the 4 screws that secure the top-most printed circuit board into the drive. Remove one of the screws and the associated lock washer, and install one of the four threaded standoffs that were included with the Drive Resident Digital MMC Control (do not use the lock washer). Repeat this process for the other 3 screws, one at a time.
6. Place the control board unit on a flat surface, with the blue plastic faceplate down, and the drive control board to the left.
7. Loosen (but do not remove....about 2 turns) the 5 screws that hold the drive control board mounting plate to the front cover plate.
8. Place the Drive Resident Digital MMC Control into the drive, inserting the connectors on the Drive Resident Digital MMC Control through the front plate.
9. Align the 20-pin connector on the Drive Resident Digital MMC Control with the 20-pin connector on the drive. Press the Drive Resident Digital MMC Control onto the

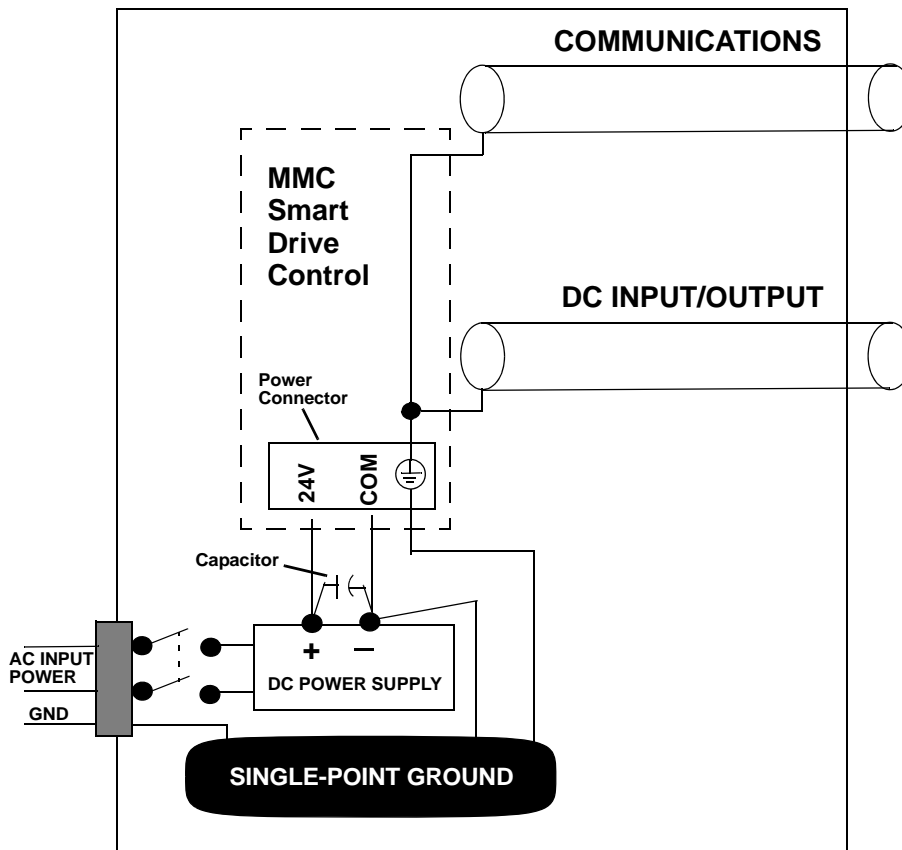
drive until the 20-pin connector is completely seated and the Drive Resident Digital MMC Control is seated against the threaded standoffs installed in step 5.

10. Tighten the 5 screws loosened in step 7
11. Fasten the Drive Resident Digital MMC Control onto the threaded standoffs using the lockwashers and screws removed in step 5.
12. Replace the control board unit back into the drive, and turn the locking screws $\frac{1}{4}$ turn counter-clockwise to secure the unit in place.

11.3 System Wiring Guidelines

The Drive Resident Digital MMC Control relies on electrical signals to report what is going on in the application and to send commands to it. In addition, signals are constantly being exchanged within the system. The Drive Resident Digital MMC Control is designed for use in industrial environments, but some guidelines should be followed.

Figure 11-2: Recommended EMC Compliant Connections



Inside a control cabinet, connect the shields of shielded cables. The two different methods of terminating shields are used to accommodate two different immunity requirements. Immunity required inside an enclosure is considered lower because cables are typically less than three meters in length and/or can be separated from each other and from noise sources.

Immunity required external to an enclosure is considered higher because the user may have less control over the noise environment. Low level signal cables that can be external to an enclosure are tested at a 2 KV level for electrical fast transients (EFTs).

Low level signals that can be less than three meters in length or can be separated from noise sources are tested at a 1 KV level. Under the stated conditions, there will be no disturbance of digital I/O, encoder, or encoder operation. For analog signals, there may be momentary disturbances but there will be self-recovery when the noise subsides.

Do not operate transmitters, arc welding equipment, or other high noise radiators within one meter of an enclosure that has the door open. Continue to equip inductive devices, if they are in series with a mechanical contact or switch, with arc suppression circuits. These devices include contactors, solenoids and motors. Shield all cables that carry heavy current near the system, using continuous foil wrap or conduit grounded at both ends. Such cables include power leads for high-frequency welders and for pulse-width-modulated motor drives.

WARNING

Use care when wiring I/O devices to the Drive Resident Digital MMC Control and when plugging in cables. Wiring the wrong device to the connector or plugging a connector into the wrong location could cause intermittent or incorrect machine operation.

11.4 Starting an Operation

Good procedure suggests that the system should be tested each time a new application is powered up. The Diagnostic LED (D2) on the Drive Resident Digital MMC Control should be off indicating that the diagnostic tests were passed.

Turn off the main disconnect switch and plug the DC connector into the power connector on the MMC-SD. Turn on input power. The D2 LED turns on and then turns off when the Drive Resident Digital MMC Control passes its diagnostic tests.

11.4.1 Connecting the Drive Resident Digital MMC Control to the Application

1. Turn off the main disconnect switch in the control cabinet. If some devices are not powered from the control cabinet, turn them off also.
2. Connect the connectors according to your diagrams.
3. Turn on power to the system. The PWR light on the MMC-SD goes on and stays on.
The D2 light goes on, then goes off in turn.
The SCAN (S) light goes on.
The application starts to work under control of the system.
4. If an application program is not in system memory, use the download command in the PiCPro software to place it there.

11.4.2 Basic Setup and Maintenance Procedures

[Table 11-1](#) below summarizes how to proceed when performing certain maintenance and/or setup functions.

Table 11-1: Troubleshooting Summary	
In order to:	Do the following:
Turn off the entire application.	Turn off main disconnect (which should also turn off all external power supplies to the application); unplug the DC power to the MMC-SD.
Wire the I/O to the application.	Turn off main disconnect (which should also turn off all external power supplies to the application); unplug the DC power to the MMC-SD.
Change the battery.	Turn off main disconnect (which should also turn off all external power supplies to the application); unplug the DC power to the MMC-SD.
Connect/disconnect the MMC with the computer workstation through the PiCPro port.	Turn off main disconnect (which should also turn off all external power supplies to the application); unplug the DC power to the MMC-SD.
Connect/disconnect the MMC with an operator interface through the User port.	Turn off main disconnect (which should also turn off all external power supplies to the application); unplug the DC power to the MMC-SD.
Download an application program into the memory.	Make sure power is on (check the P LED) on the MMC-SD.
Stop the scan.	From the workstation - use the Stop Scan commands in the PiCPro software.

11.4.3 Start-up Diagnostics

When the system is powered up, it tests itself and reports the results in the form of LED signals.

11.4.3.1 Power LED

If the Power LED (P) on MMC-SD does not go on, or goes off during operation of the system, check that power is still connected to the MMC-SD. If the power LED on the MMC-SD is on, turn off the main disconnect switch and replace the Drive Resident Digital MMC Control.

11.4.3.2 Scan LED

If the SCAN (S) LED does not go on:

1. Check that the power (P) light is ON.
2. Check that the diagnostic (D2) light is OFF.

11.4.3.3 Drive Resident Digital MMC Control Start-Up Diagnostic LEDs

The LED D2 light on the Drive Resident Digital MMC Control lights up briefly while its diagnostic tests are running and then goes off. If D2 remains on, the Drive Resident Digital MMC Control has failed one of its tests. Follow these steps:

1. Turn off power to the system and to the application.
2. If the I/O wiring is connected, remove the connector.
3. Remove the defective Drive Resident Digital MMC Control from the drive.
4. Replace with a new Drive Resident Digital MMC Control. Connect the I/O wiring.
5. Turn on power to check diagnostics again.

NOTE
Diagnosics are run only when the system is powered up. It is possible that a failure might occur during operation. If so, D2 remains off. If you suspect that a module might be defective, cycle power to run diagnostics again.

11.4.4 MMC Run-Time Diagnostics

While the Drive Resident Digital MMC Control is running, other tests are performed on a regular basis with their results also reported by D2.

While the Drive Resident Digital MMC Control is running, the D2 will flash a three digit code signal if there is an error. For example, if there is a long pause-flash-pause-flash-flash-pause-flash-flash-flash-long pause, the code is 123.

Code	Error	Description
123	Scan too long	A ladder scan loss has occurred because the CPU takes more than 200 ms to scan the application program. Whenever the scan light is out, the discrete outputs go to the OFF state and the analog outputs are zeroed.
124	Excessive overhead	The system overhead update time is excessive.
125	Insufficient memory	There is insufficient memory on the CPU to run the current program.
126	No hardware bit memory	There is no bit memory installed on the CPU and the program requires it.
127	No software bit memory	There is no bit memory capability via software and the program requires it.
222	Driver error	No driver support on the CPU for the I/O module. Update your system EPROMs.
22_	Master rack error	The I/O modules in the master rack do not match what was declared in the hardware master declaration table. The number of flashes in the third digit (__) identifies the slot number that is in error.
232	Communications error	A failure has occurred in remote I/O communications.
3_ _	Expansion rack error	The I/O modules in the block I/O modules do not match what was declared in the expansion hardware declaration table. For block I/O modules: The number of flashes in the second and third digits indicates the block I/O module (01 through 77). The second digit will flash a 1 - 7, 10 for 0. The third digit will flash a 1 - 9, 10 for 0. For example, if the second digit flashes 3 times and the third digit flashes 10 times, the module is 30 .
621	Low Battery	The battery on the Control is near its end of life, and needs to be replaced.

11.5 Connectors & Operation

Kollmorgen provides many optional accessories that simplify wiring the Drive Resident Digital MMC Control to external devices.

These accessories include cables to connect MMC-SD drives together and breakout boxes that provide screw-terminal connections to the Drive Resident Digital MMC Control. Contact Kollmorgen for further information.

11.5.1 PiCPro Port (P1)

The PiCPro Port (P1) connector provides serial communication for the PiCPro programming interface. PiCPro Port (P1) is physically located on the MMC-SD faceplate. Refer to Chapter 5 for information on the PiCPro (P1) Port.

Note: PiCPro can also be run over from the Ethernet (C4) connector.

11.5.2 Block I/O Port (C1)

The 9-pin female D-sub PiCPro Port connector (labeled “C1” on the front of the Control) provides serial communication between 1 to 77 Block I/O modules and the Control. Cables connecting the Control to the first Block I/O Module and between Block I/O modules can be up to 200 feet in length.

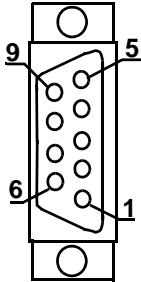
Note: The Block I/O Port (C1) is not included on the Digital MMC-D1.

- Pin descriptions for are provided in [Table 11-3](#).
- Pin assignments are provided in [Table 11-4](#).
- The available Flying Lead cable is described in [Table 11-5](#).
- Connections to the Block I/O Module are described in [Table 11-6](#).
- Available Breakout Boxes and Cables are described in [Table 11-7](#).
- Breakout Box dimensions are shown in [Figure 11-3](#)

Table 11-3: Block I/O Port Pin Descriptions

Function	Notes	Pin
Transmit Data +	Transmits data to Block I/O Modules.	3
Transmit Data -	Transmits data to Block I/O Modules.	4
Receive Data +	Receives data from Block I/O Modules.	5
Receive Data -	Receives data from Block I/O Modules.	6
Shield Ground	Provides a path for shield current through the chassis to an external single point ground.	7 & Shell

Table 11-4: Block I/O Port Pin Assignment

Pin	Signal	In/Out	Connector Pinout
1	NC	N/A	9-pin female D-sub 
2	N/C	N/A	
3	Transmit Data +	Out	
4	Transmit Data -	Out	
5	Receive Data +	In	
6	Receive Data -	In	
7	Shield	In	
8	NC	N/A	
9	NC	N/A	
Connector Shell	Drain	In	

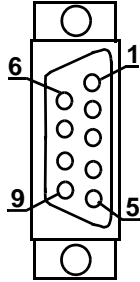
NOTE

Pin 7 of the Block I/O port connector is connected to the connector shell within the MMC. Therefore, the shield may be connected to either pin 7 or the connector shell.

Table 11-5: Block I/O Port to Flying Lead Cable

Part Number: M.1016.2568
 Length: 3 M (10 ft)
 Cable type: 24 AWG, twisted pair (individually shielded), 4 conductor.

9-Pin male D-sub (to Block I/O Port, face view)



Pin	Signal	Color	Notes
3	Transmit Data +	White	Twisted Pair with Shield
4	Transmit Data -	Black	
7	Shield	N/A	
5	Receive Data +	Red	Twisted Pair with Shield
6	Receive Data -	Black	
7	Shield	N/A	

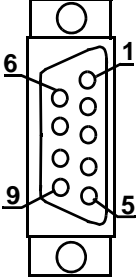
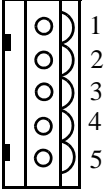
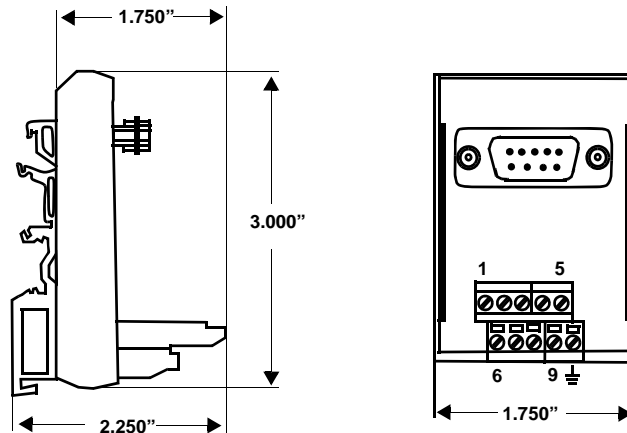
Table 11-6: Block I/O Port to Block I/O Module Wiring				
Use this table to wire from the Block I/O Port to the first Block I/O Module.				
9-Pin male D-sub (to Block I/O Port, face view)		5-Pin Pluggable Screw Terminal (to Block I/O Module, face view)		
				
Pin	Signal	Pin	Signal	Notes
3	Transmit Data +	1	Receive Data +	Twisted Pair
4	Transmit Data -	2	Received Data -	
5	Receive Data +	4	Transmit Data +	Twisted Pair
6	Received Data -	5	Transmit Data -	
7	Shield Ground	3	Shield Ground	
Shell	Drain	Shell	Drain	

Table 11-7: Block I/O Port Breakout Box and Cables^a		
Description	Length	Part Number
MMC Block I/O Breakout Box	N/A	M.1016.2533
MMC Block I/O Connector to Breakout Box Cable	.3 M (1 ft)	M.1016.2543
MMC Block I/O Connector to Breakout Box Cable	.6 M (2 ft)	M.1016.2544
MMC Block I/O Connector to Breakout Box Cable	.9 M (3 ft)	M.1016.2545

a. The Breakout Box (see [Figure 11-3 on page 213](#)) is DIN-rail mounted, and provides screw terminal wire termination. It can be attached to the “C1” port on the Control. The pinouts on the terminal strip interface provide a one-to-one transfer of the signals from the connector to the respective pin(s) on the terminal block. The connector pins marked with the “ground” symbol on the screw connector are connected to the “D” connector shell for shield grounding purposes.

Figure 11-3: Block I/O Breakout Box Dimensions

11.5.3 User Port

The 15-pin HD male D-sub User Port connector (labeled “C3” on the front of the Control) provides RS232 and RS485 serial communication between a serial device and the Control. The User Port provides RS232/RS485 communications at Baud rates to 115.2 K with Multidrop capability.

- Pin descriptions are provided in [Table 11-8](#)
- Pin assignments are provided in [Table 11-9](#)
- The available Flying Lead cable is described in [Table 11-10](#).
- The available RS-232 Exter HMI cable is described in [Table 11-11](#).
- The available RS-485 Exter HMI cable is described in [Table 11-12](#).
- Available Breakout Boxes and Cables are described in [Table 11-13](#).
- Breakout Box dimensions are shown in [Figure 11-4](#)

Table 11-8: User Port Pin Descriptions		
Function	Notes	Pin
RS232 Receive Data	RS232-level signal that receives serial data from the connected serial device.	9
RS232 Transmit Data	RS232-level signal that sends serial data to the connected serial device.	10
RS232 Request-to-send	RS232-level signal that indicates to the connected serial device that it can transmit data to the Control.	5
RS232 Clear-to-send	RS232-level signal that indicates to the Control that it can transmit data to the connected serial device.	7
RS-232 Data-terminal-ready	This output from the Control is always high (12 Vdc).	4
RS-485 Receive Data +	RS485-level signal that receives serial data from the connected serial device(s).	12
RS-485 Receive Data -	RS485-level signal that receives serial data from the connected serial device(s).	13
RS-485 Transmit Data +	RS485-level signal that transmits serial data to the connected serial device(s).	14
RS-485 Transmit Data -	RS485-level signal that transmits serial data to the connected serial device(s).	15
Signal Ground	Provides the return path for signals	8
Shield Ground	Provides a path for shield current through the chassis to an external single point ground.	Shell

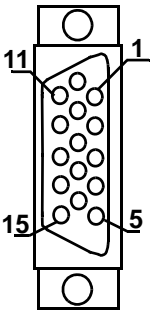
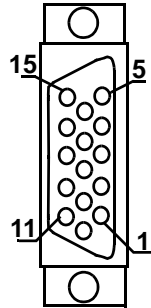
Table 11-9: User Port Pin Assignments			
Pin	Signal	In/Out	Connector Pinout
1	NC	N/A	15-pin HD male D-sub 
2	N/C	N/A	
3	N/C	N/A	
4	RS232 Data-terminal-ready (12 Vdc)	Out	
5	RS232 Request-to-Send	Out	
6	N/C	N/A	
7	RS232 Clear- to-Send	In	
8	Signal Ground	In/Out	
9	RS232 Receive Data	In	
10	RS232 Transmit Data	Out	
11	N/C	N/A	
12	RS485 Receive Data +	In	
13	RS485 Receive Data -	In	
14	RS485 Transmit Data +	Out	
15	RS485 Transmit Data -	Out	
Connector Shell	Drain	In	

Table 11-10: User Port to Flying Lead Cable

Part Number: M.1016.2565
 Length: 3 M (10 ft)
 Cable type: 28 AWG, shielded, twisted pair, 16 conductor.

15-Pin HD female D-sub (to User Port, face view)

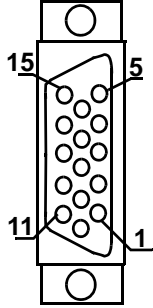


Pin	Signal	Color	Notes
3	N/C	Blue	Twisted
8	Signal Ground	Blue/Black	Pair
12	RS485 Receive Data +	Brown	Twisted
13	RS485 Receive Data -	Brown/Black	Pair
14	RS485 Transmit Data +	Violet	Twisted
15	RS485 Transmit Data -	Violet/Black	Pair
4	RS232 Data-terminal Ready	White	
5	RS232 Request-to-send	Red	
7	RS232 Clear-to-send	Green	
9	RS232 Receive Data	Yellow	
10	RS232 Transmit Data	Orange	
Shell	Drain	N/A	

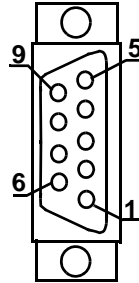
Table 11-11: User Port to RS-232 Exter HMI Cable

Part Number: M.1302.8453
 Length: 4 M (13 ft)
 Cable type: 24 AWG, shielded, twisted pair, 4 conductor.

15-Pin HD female D-sub
 (to User Port, face view)



9-Pin female D-sub (to
 Exter HMI COM2 Port,
 face view)



Pin	Signal	Pin	Signal	Notes
9	Receive Data	3	Transmit Data	Twisted
10	Transmit Data	2	Receive Data	Pair
8	Signal Ground	5	Signal Ground	
Shell	Drain	Shell	Drain	

Table 11-12: User Port to RS-485 Exter HMI Cable

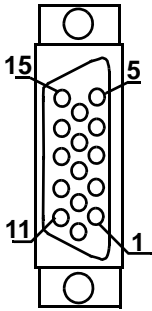
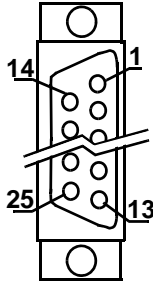
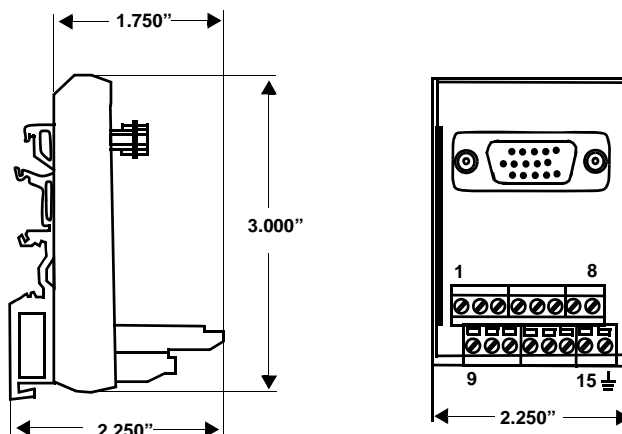
Part Number: M.1302.8454 Length: 4 M (13 ft) Cable type: 24 AWG, shielded, twisted pair, 6 conductor.				
15-Pin HD female D-sub (to User Port, face view)		25-Pin male D-sub (to Exter HMI COM1 Port, face view)		
				
Pin	Signal	Pin	Signal	Notes
12	Receive Data+	2	Transmit Data+	Twisted
13	Receive Data-	15	Transmit Data-	Pair
14	Transmit Data+	3	Receive Data+	Twisted
15	Transmit Data-	16	Receive Data-	Pair
8	Signal Ground	7	Signal Ground	
Shell	Drain	Shell	Drain	

Table 11-13: User Port Breakout Box and Cables^a

Description	Length	Part Number
MMC User Port Breakout Box	N/A	M.1016.2530
MMC User Port to Breakout Box Cable	.3 M (1 ft)	M.1016.2715
MMC User Port to Breakout Box Cable	.6 M (2 ft)	M.1016.2716
MMC User Port to Breakout Box Cable	.9 M (3 ft)	M.1016.2717

a. The Breakout Box (see [Figure 11-4 on page 219](#)) is DIN-rail mounted, and provides screw terminal wire termination. It can be attached to the “C3” connector on the Control. The pinouts on the terminal strip interface provide a one-to-one transfer of the signals from the connector to the respective pin(s) on the terminal block. The connector pins marked with the “ground” symbol on the screw connector are connected to the “D” connector shell for shield grounding purposes.

Figure 11-4: User Port Breakout Box Dimensions



11.5.4 Ethernet Port

The 8-pin RJ-45 Ethernet Port connector (labeled “C4” on the front of the Control) provides IEEE 802.3/802.3u-100Base-TX/10Base T, half duplex connectivity between an Ethernet device and the Control. Also provided on near the RJ-45 connector is a green “Link” light (which will be on if there is either a 100Base-T or 10Base-T Link) and a green “Activity” light (which will be on whenever a send or receive packet has occurred on the network).

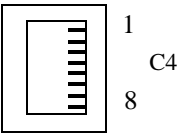
Communication using the Ethernet Port can be between the Control and a PC, User Interface, or other Ethernet device or network. For example, PiCPro running on a PC can communicate to the Control through this Ethernet connector.

Typically, a “straight-through” shielded cable should be used when connecting the Control to another Ethernet device.

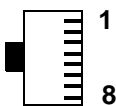
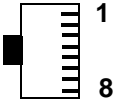
- Pin descriptions for are provided in [Table 11-14](#)
- Pin assignments are provided in [Table 11-15](#)
- The available Ethernet Port to Ethernet Device cables are described in [Table 11-16](#)

Table 11-14: Ethernet Port Pin Descriptions		
Function	Notes	Pin
Receive Data +	Receives data from connected device.	3
Receive Data -	Receives data from connected device.	6
Transmit Data +	Transmits data to connected device.	1
Transmit Data -	Transmits data to connected device.	2

Table 11-14: Ethernet Port Pin Descriptions		
Function	Notes	Pin
Shield Ground	Provides a path for shield current through the chassis to an external single point ground.	Shell

Table 11-15: Ethernet Port Pin Assignments			
Pin	Signal	In/Out	Connector Pinout
1	Transmit Data +	Out	RJ-45 
2	Transmit Data -	Out	
3	Receive Data +	In	
4	Termination Resistors ^a	In	
5	Termination Resistors ^(a)	In	
6	Receive Data -	In	
7	Termination Resistors ^(a)	In	
8	Termination Resistors ^(a)	In	
Connector Shell	Shield	In	

a. Pins 4, 5, 7, and 8 are tied to termination resistors on the Control. Standard Ethernet cables contain 8 wires. The Control only uses 4 of these wires as shown. Connecting the 4 unused wires to pins 4, 5, 7, and 8, (as will be done in a standard Ethernet cable) reduces noise that can be induced from the unused wires to the Transmit and Receive wires.

Table 11-16: Ethernet Port to Ethernet Device Cables				
Part Numbers: .3 M (1.0 ft): M.1302.8285 .6 M (2.0 ft): M.1302.8286 1 M (3.3 ft): M.1302.8287 2 M (6.6 ft): M.1302.8288 3 M (9.8 ft): M.1302.8289 5 M (16.4 ft): M.1302.8300 10 M (32.8 ft): M.1302.8301 15 M (49.2 ft): M.1302.8302 30 M (98.4 ft): M.1302.8303 Cable type: 28 AWG, shielded, twisted pair, 8 conductor.				
8-Pin RJ-45 Plug (to Ethernet Port, face view) 		8-Pin RJ-45 Plug (to Ethernet Device, face view) 		
Pin	Signal	Pin	Signal	Notes
1	Transmit Data +	1	Receive Data +	Twisted
2	Transmit Data -	2	Receive Data -	Pair
3	Receive Data +	3	Transmit Data +	Twisted
6	Receive Data -	6	Transmit Data -	Pair
4	None	4	None	Twisted
5	None	5	None	Pair
7	None	7	None	Twisted
8	None	8	None	Pair
Shell	Drain	Shell	Drain	

11.5.5 General I/O Port (C5)

The 26-pin HD male D-sub General I/O Port connector (labeled “C5” on the front of the Control) provides connection between user I/O devices and the Control. This port provides 8 source-only, 250ma, short-circuit protected outputs (described in detail in [section 11.5.5.1 on page 226](#)), and 8 source-only inputs (described in detail in [section 11.5.5.2 on page 228](#)).

- Pin descriptions are provided in [Table 11-17](#)
- Pin assignments are provided in [Table 11-18](#)
- The available Flying Lead cable is described in [Table 11-19](#).
- Available Breakout Boxes and Cables are described in [Table 11-20](#).
- Breakout Box dimensions are shown in [Figure 11-5](#)

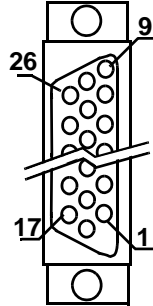
Table 11-17: General I/O Port Pin Descriptions		
Function	Notes	Pin
DC Outputs 1-8	Nominal 24 Vdc Outputs capable of sourcing up to 250 ma.	1-8
DC Inputs 1-8	Nominal 24 Vdc sourcing Inputs	19-26
DC Output Power	This is the 24 Vdc supplied by the user to power the DC Outputs	9
I/O 24 Volts	These pins are only connected to each other within the Control. If used, connect one pin to 24 Vdc, and the other pins to one side of input devices.	10-13
24 Vdc Common	These pins are only connected to each other within the Control. Connect pin 14 to 24V Common. This provides the return path for the 24 Vdc Inputs. Connect pins 15-18 to one side of output devices if desired.	14-18
Shield Ground	Provides a path for shield current through the chassis to an external single point ground.	Shell

Table 11-18: General I/O Port Pin Assignments			
Pin	Signal	In/Out	Connector Pinout
1	DCOUT1	Out	<p>26-pin HD male D-sub</p>
2	DCOUT2	Out	
3	DCOUT3	Out	
4	DCOUT4	Out	
5	DCOUT5	Out	
6	DCOUT6	Out	
7	DCOUT7	Out	
8	DCOUT8	Out	
9	24VDCIN	In	
10-13	IO24V	In/Out	
14-18	IO24C	In/Out	
19	DCIN1	IN	
20	DCIN2	IN	
21	DCIN3	IN	
22	DCIN4	IN	
23	DCIN5	IN	
24	DCIN6	IN	
25	DCIN7	IN	
26	DCIN8	IN	
Shell	Drain	In	

Table 11-19: General I/O Port to Flying Lead Cable

Part Numbers:
 1 M (3.3 ft): M.1302.8257 15 M (49.2 ft): M.1302.8290
 3 M (10 ft): M.1302.8258 30 M (98.4 ft): M.1302.8291
 9 M (29.5 ft): M.1302.8259
 Cable type: 28 AWG (pins 9 & 10 are 20 AWG), shielded, twisted pair, 26 conductor.

26-Pin HD female D-sub (to Gen I/O Port, face view)



Pin	Signal	Color	Notes	Pin	Signal	Color	Notes
1	DCOUT1	Blk	Twisted	15	IO24C	Brn	Twisted
2	DCOUT2	Wht/Blk	Pair	16	IO24C	Wht/Brn	Pair
3	DCOUT3	Red	Twisted	17	IO24C	Vio	Twisted
4	DCOUT4	Wht/Red	Pair	18	IO24C	Wht/Vio	Pair
5	DCOUT5	Grn	Twisted	19	DCIN1	Pnk	Twisted
6	DCOUT6	Wht/Grn	Pair	20	DCIN2	Wht/Pnk	Pair
7	DCOUT7	Org	Twisted	21	DCIN3	Blk/Yel	Twisted
8	DCOUT8	Wht/Org	Pair	22	DCIN4	Gry/Grn	Pair
9	24VDCIN	Gry	Twisted	23	DCIN5	Grn/Red	Twisted
10	IO24V	Wht/Gry	Pair	24	DCIN6	Yel/Red	Pair
11	IO24V	Blu	Twisted	25	DCIN7	Gry/Blu	Twisted
12	IO24V	Wht/Blu	Pair	26	DCIN8	Yel/Blu	Pair
13	IO24V	Yel	Twisted				
14	IO24C	Wht/Yel	Pair				
Shell	Drain	N/A					

Table 11-20: General I/O Port Breakout Box and Cables ^a		
Description	Length	Part Number
DR Control Gen I/O Breakout Board ^b	N/A	M.1302.8480
DR Control Gen I/O Breakout Box ^c	N/A	M.1302.8253
DR Control Gen I/O & Aux I/O Connector to Breakout Box Cable	1 M (3.3 ft)	M.1302.8254
	3 M (9.8 ft)	M.1302.8255
	9 M (29.5 ft)	M.1302.8256

- a. The connector pins marked with the “ground” symbol on the screw connector are connected to the “D” connector shell for shield grounding purposes.
- b. The Breakout Board is mounted directly to the General I/O connector, and provides screw terminals wire termination.
- c. The Breakout Box (see [Figure 11-5 on page 225](#)) is DIN-rail mounted, and provides screw terminal wire termination. Use one of the cables listed in the table to connect between the General I/O connector and the Breakout Box.

Figure 11-5: General I/O Port Breakout Box Dimensions

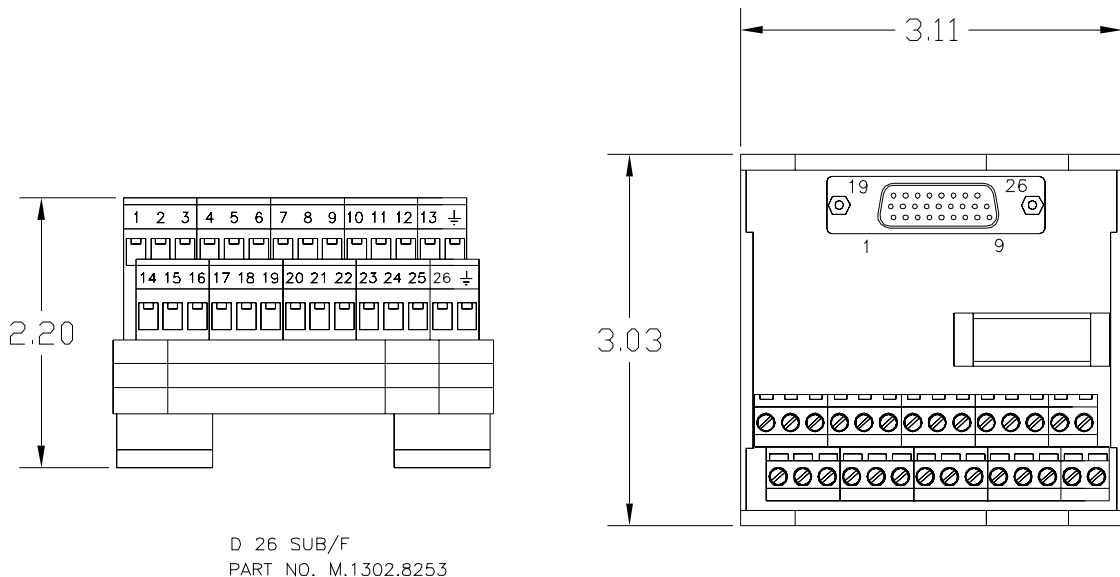
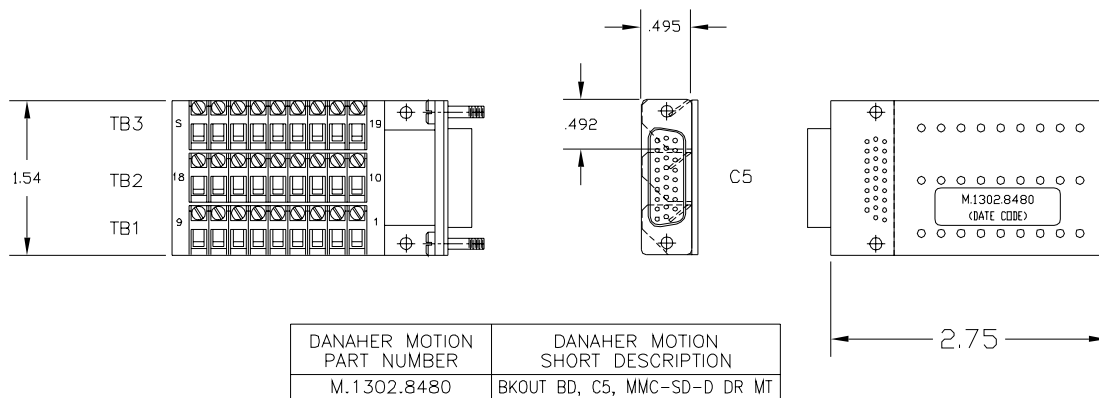


Figure 11-6: General I/O Port Breakout Board Dimensions



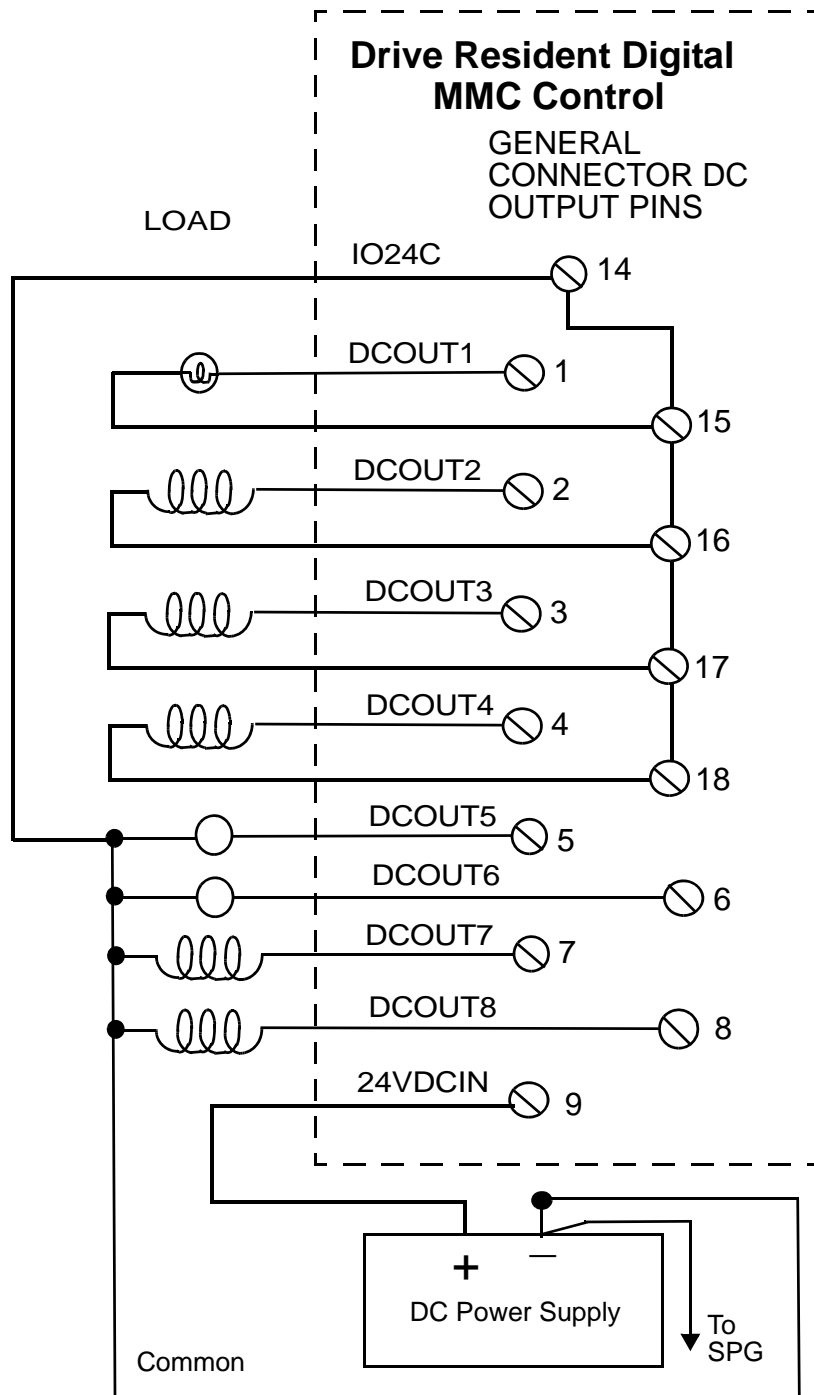
11.5.5.1 DC Output Operation

The General I/O Port provides 8 source-only 24 Vdc outputs. These outputs get their power from Pin 9 of the General I/O connector. Each of the 8 outputs on the general I/O connector is a solid state switch rated at 250 ma. An example of connecting the DC Outputs to loads is shown in [Figure 11-7](#).

When a short circuit condition is sensed, all outputs in the group are turned off and remain off for approximately 100 ms regardless of ladder activity. After 100 ms, the ladder again controls the outputs. In addition, each output is protected with internal clamping diodes. Without clamping, high voltage transients (kickback) from inductive loads might damage the module.

For safety reasons, all outputs turn off (no current flow) when a scan loss condition occurs.

Figure 11-7: Connecting Output Devices to the General I/O Port (C5)

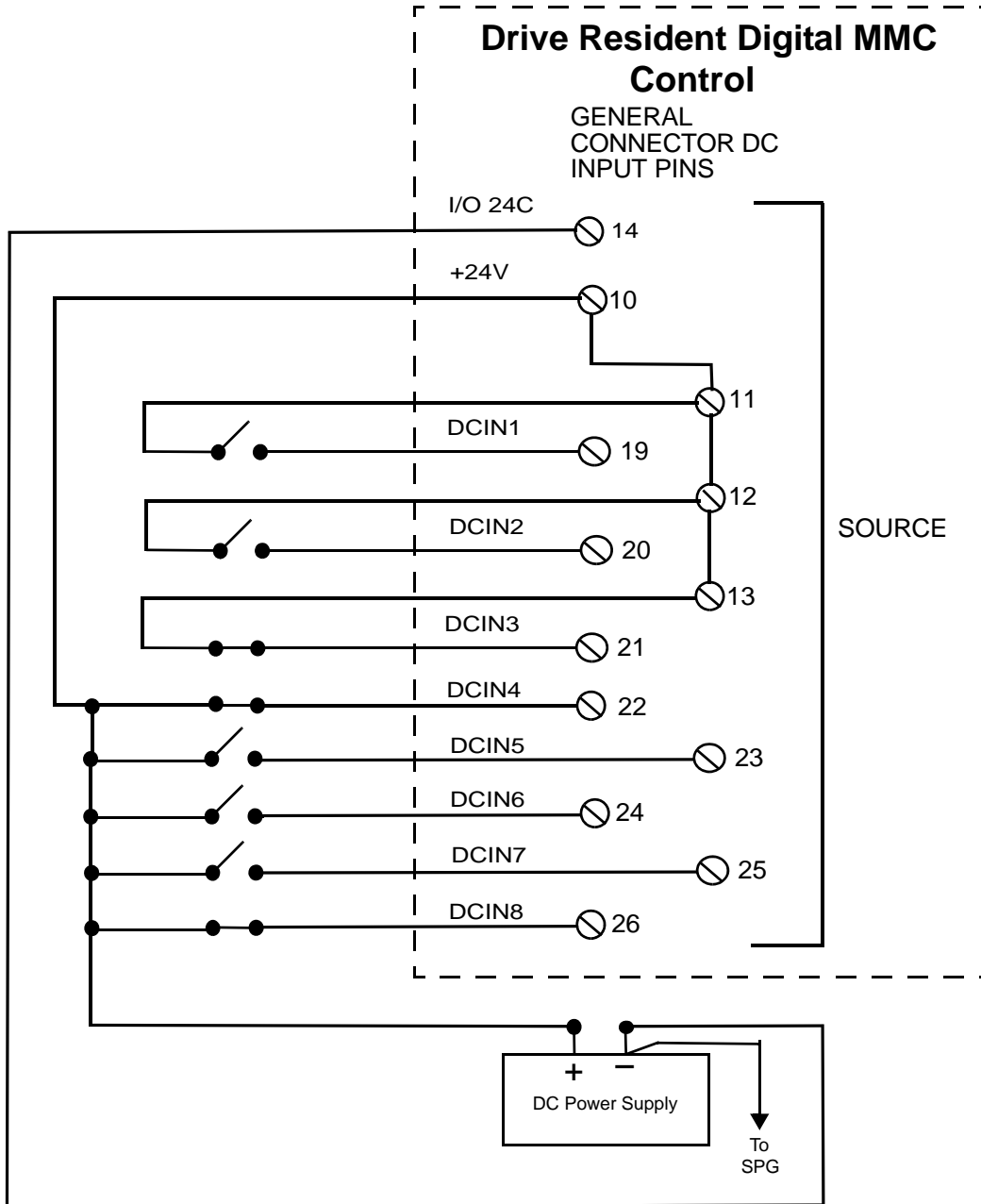


11.5.5.2 DC Input Operation

The General I/O Port provides eight 24 Vdc sourcing inputs.

An example of connecting the DC Inputs to the Control is shown in [Figure 11-8](#).

Figure 11-8: Connecting Input Devices to the General I/O Port (C5)



11.6 Specifications

General											
Characteristic		MMC Specifications									
		Number of servo axes available at six update rates ^a									
Model	Part No.	Speed	App Mem	RAM Mem	User Mem	8 ms	4 ms	2 ms	1 ms	.5 ms	.25 ms
Digital MMC-D1	M.3000 .0164	Std.	1.3M	256K	64K	1	1	1	1	1	1
Digital MMC-D2	M.3000 .0165	Std.	1.3M	256K	64K	2	2	2	2	2	1
Digital MMC-D4	M.3000 .0166	Std.	1.3M	256K	64K	4	4	4	4	2	1
Digital MMC-D8	M.3000 .0518	X1.5	1.3M	256K	64K	8	8	8	4-8	2-4	1-2
Digital MMC-D16	M.3000 .0167	X1.5	1.3M	256K	64K	16	16	8-16	4-8	2-4	1-2

a. Using features such as servo tasks, S-curve, RATIO_RL, M_LINCIR, M_SCRVLC, PLS, and CAM_OUT places a heavier burden on available CPU time. Consult Kollmorgen for assistance if you want to exceed the number of axes in this chart.

CPU	32 bit RISC processor with numeric coprocessor
Battery	3V Coin Cell, BR2032 lithium battery
Battery Life	2 power-off years (typical)
CAUTION for Lithium Batteries Danger of explosion if battery is incorrectly replaced. Replace only with the same or equivalent type recommended by the manufacturer. Dispose of used batteries according to the manufacturer's instructions.	
Flash Disk	2 Megabytes
Memory	1 Megabyte max.
PiCPro Port (to workstation)	RS232 serial port, secured protocol Software selectable baud rate to 115.2K
User Port (to serial interface device)	RS232/RS485 serial port Supports RTS/CTS hardware handshaking Software selectable baud rate to 115.2K
Ethernet Port (to Ethernet Device)	IEEE 802.3/802.3u-100Base-TX/10Base T Half duplex Cable type: Shielded, Straight Pinned, CAT5 or better (CAT5e, CAT6, etc.) Maximum cable length: 82.5 ft (25 m)

Input voltage from MMC-SD Drive	20 VDC to 30 VDC
Input power from MMC-SD Drive	250 mA
Time-of-day clock Clock tolerance	Access via PiCPro 10.2 and above or your application program At 25°C (77°F), ±1 second per day Over temperature, voltage and aging variation, +2/-12 seconds per day
General DC Inputs	
Configuration	Sourcing only. Operates with IEC Type 1 inputs (per IEC 1131-2)
Input voltage	Nominal 24 VDC, maximum 30 VDC
Guaranteed on voltage	15 VDC
Guaranteed off voltage	5 VDC
Turn on/off time	1 ms
General DC Outputs	
Number of outputs	8 outputs
Input voltage	Nominal 24 VDC, 30 VDC maximum
Configuration	Eight solid-state switches.
Protection of logic circuits	Optical isolation between the logic and field side, transient suppression on the 24V external supply
Maximum current	.25 A per output
Voltage range	24 VDC nominal, 5 to 30 VDC
Switch characteristics	Solid-state switches
Time delay on for resistive loads	50 µsec max
Time delay off for resistive loads	50 µsec max
Leakage current in off state	0.5 mA max
Switch voltage, maximum ON	1 VDC max
Short circuit protection for each group	15 A (max) pulses for about 130 µsec every 100 msec until short is removed
Scan loss response	Outputs turn off

12 Part Numbers

12.1 230V Smart Drives

DESCRIPTION	MODEL NUMBER	PART NUMBER
2.5A Cont. / 7.5A Max./ .5kW		
Analog, standard width	MMC-SD-0.5-230	M.1302.5090
Digital, standard width without BiSS	MMC-SD-0.5-230-D	M.1302.8130
Digital, standard width with BiSS	MMC-SD-0.5-230-D	M.3000.0461
Digital, narrow width without BiSS	MMC-SD-0.5-230-DN	M.1302.8908
Digital, narrow width with Biss	MMC-SD-0.5-230-DN	M.3000.0458
5A Cont. / 15A Max./ 1kW		
Analog, standard width	MMC-SD- 1.0-230	M.1302.5091
Digital, standard width without BiSS	MMC-SD-1.0-230-D	M.1302.8131
Digital, standard width with BiSS	MMC-SD-1.0-230-D	M.3000.0462
Digital, narrow width without BiSS	MMC-SD-1.0-230-DN	M.1302.8910
Digital, narrow width with Biss	MMC-SD-1.0-230-DN	M.3000.0459
10A Cont. / 30A Max / 2kW		
Analog, standard width	MMC-SD-2.0-230	M.1302.5092
Digital, standard width without BiSS	MMC-SD-2.0-230-D	M.1302.8132
Digital, standard width with BiSS	MMC-SD-2.0-230-D	M.3000.0463
Digital, narrow width without BiSS	MMC-SD-2.0-230-DN	M.1302.8911
Digital, narrow width with Biss	MMC-SD-2.0-230-DN	M.3000.0460

12.2 460V Smart Drives

DESCRIPTION	MODEL NUMBER	PART NUMBER
3.0A Cont. / 6.0A Max. / 1.3 kW		
Analog	MMC-SD-1.3-460	M.1302.5093
Digital, without BiSS	MMC-SD-1.3-460-D	M.1302.8133
Digital, with BiSS	MMC-SD-0.5-230-D	M.3000.0464
5.5A Cont. / 11.0A Max. / 2.4 kW		
Analog	MMC-SD-2.4-460	M.1302.5094
Digital, without BiSS	MMC-SD-2.4-460-D	M.1302.8134
Digital, with BiSS	MMC-SD-2.4-460-D	M.3000.0465
9.0A Cont. / 18.0A Max. / 4.0 kW		
Analog	MMC-SD-4.0-460	M.1302.5095
Digital, without BiSS	MMC-SD-4.0-460-D	M.1302.8135
Digital, with BiSS	MMC-SD-4.0-460-D	M.3000.0466
13.5A Cont. / 27.0A Max. / 6.0 kW		
Analog	MMC-SD-6.0-460	M.1302.5096
Digital, without BiSS	MMC-SD-6.0-460-D	M.1302.8136
Digital, with BiSS	MMC-SD-6.0-460-D	M.3000.0467
18.0A Cont. / 36.0A Max. / 8.0 kW		
Analog	MMC-SD-8.0-460	M.1302.5097
Digital, without BiSS	MMC-SD-8.0-460-D	M.1302.8137
Digital, with BiSS	MMC-SD-8.0-460-D	M.3000.0468
27.5A Cont. / 55.0A Max. / 12.0 kW		
Analog	MMC-SD-12.0-460	M.1302.5098
Digital, without BiSS	MMC-SD-12.0-460-D	M.1302.8138
Digital, with BiSS	MMC-SD-12.0-460-D	M.3000.0469

DESCRIPTION	MODEL NUMBER	PART NUMBER
36.5A Cont. / 73.0A Max. / 16.0 kW		
Analog	MMC-SD-16.0-460	M.1302.5099
Digital, without BiSS	MMC-SD-16.0-460-D	M.1302.8139
Digital, with BiSS	MMC-SD-16.0-460-D	M.3000.0470
55.0A Cont. / 110.0A Max. / 24.0 kW		
Analog	MMC-SD-24.0-460	M.1302.5100
Digital, without BiSS	MMC-SD-24.0-460-D	M.1302.8140
Digital, with BiSS	MMC-SD-24.0-460-D	M.3000.0471
69.3A Cont. / 110.0A Max. / 30.0 kW		
Analog	MMC-SD-30.0-460	M.3000.0545
Digital, with BiSS	MMC-SD-30.0-460-D	M.3000.0021
93.3A Cont. / 147.0A Max. / 42.0 kW		
Analog	MMC-SD-42.0-460	M.3000.0546
Digital, with BiSS	MMC-SD-42.0-460-D	M.3000.0022
117.4A Cont. / 189.0A Max. / 51.0 kW		
Analog	MMC-SD-51.0-460	M.3000.0547
Digital, with BiSS	MMC-SD-51.0-460-D	M.3000.0023
152.7A Cont. / 209.0A Max. / 65.0 kW		
Analog	MMC-SD-65.0-460	M.3000.0548
Digital, with BiSS	MMC-SD-65.0-460-D	M.3000.0024

12.3 S200-DLS Drives and Accessories

DESCRIPTION ^a	MODEL NUMBER	PART NUMBER
3.0A Continuous @ 40 degrees C	S20360-DLS	S20360-DLS
6.0A Continuous @ 40 degrees C	S20660-DLS	S20660-DLS
12.0A Continuous @ 40 degrees C	S21260-DLS	S21260-DLS
24.0A Continuous @ 40 degrees C	S22460-DLS	S22460-DLS
Aux Feedback Port ENDAT/BiSS to AKM/DDR Motor Cable 1 M (3.3 ft)	N/A	M.1302.0809
Aux Feedback Port ENDAT/BiSS to AKM/DDR Motor Cable 3 M (9.8 ft)	N/A	M.1302.0810
Aux Feedback Port ENDAT/BiSS to AKM/DDR Motor Cable 6 M (19.7 ft)	N/A	M.1302.0811
Aux Feedback Port ENDAT/BiSS to AKM/DDR Motor Cable 9 M (29.5 ft)	N/A	M.1302.0812
Aux Feedback Port ENDAT/BiSS to AKM/DDR Motor Cable 15 M (49.2 ft)	N/A	M.1302.0813
Aux Feedback Port ENDAT/BiSS to AKM/DDR Motor Cable 30 M (98.4 ft)	N/A	M.1302.0814
6-pin spring-contact pluggable mating connector for the I/O Power Port (J6)	N/A	M.1302.7662
8-pin spring-contact pluggable mating for connector for the Drive I/O Port (J7)	N/A	M.1302.7627

- a. For S200 Base Unit cables and connectors, please refer to the S200 Base Unit Reference Manual, P/N M-SM-200-01, which can be found at http://www.kollmorgen.com/website/com/eng/products/drives/ac_servo_drives/s200_manuals.php.

12.4 Combination Fuses

Combination Fuse	Fuse Part Number	Fuse Holder Type 3P	Fuse Holder Part Number
DFJ6	M.3000.0190	30 Amp	M.1016.1046
DFJ15	M.3000.0191	30 Amp	M.1016.1046
DFJ20	M.3000.0192	30 Amp	M.1016.1046
DFJ25	M.3000.0193	30 Amp	M.1016.1046
DFJ30	M.3000.0194	30 Amp	M.1016.1046
DFJ35	M.3000.0195	60 Amp	M.1016.0612
DFJ40	M.3000.0196	60 Amp	M.1016.0612
DFJ45	M.3000.0197	60 Amp	M.1016.0612
DFJ60	M.3000.0198	60 Amp	M.1016.0612
DFJ80	M.3000.0199	100 Amp	M.1016.0613
DFJ100	M.3000.0200	100 Amp	M.1016.0613
DFJ110	M.3000.0201	200 Amp	M.1016.0614
DFJ125	M.3000.0202	200 Amp	M.1016.0614
DFJ150	M.3000.0203	200 Amp	M.1016.0614
DFJ175	M.3000.0204	200 Amp	M.1016.0614

12.5 Option Modules

12.5.1 Resolver Interface Option Module

Module	Model Number	Part Number
Resolver Interface Option Module		M.1302.4523

12.5.2 Drive Resident Digital MMC Control

Drive Resident Digital MMC Control	Model Number	Part Number
1 Axis Controller	Digital MMC-D1	M.3000.0164
2 Axis Controller	Digital MMC-D2	M.3000.0165
4 Axis Controller	Digital MMC-D4	M.3000.0166
8 Axis Controller	Digital MMC-D8	M.3000.0518
16 Axis Controller	Digital MMC-D16	M.3000.0167

12.6 Direct Connect Cables

12.6.1 Drive Programming Cable

Description	Drive Connector	Part Number
PiCPro Port to PC Connector (Analog)	P1	M.1302.8250
PiCPro Port to PC Connector (Digital)		M.1302.8284

12.6.2 Standalone MMC to MMC Smart Drive I/O Cable

Description	Drive Connector	Part Number
MMC A'n' to MMC Smart Drive I/O 0.5M	IO	M.1302.5990
MMC A'n' to MMC Smart Drive I/O 1.0M		M.1302.5991
MMC A'n' to MMC Smart Drive I/O 1.5M		M.1302.5992
MMC A'n' to MMC Smart Drive I/O 3.0M		M.1302.5993

12.7 Digital Link and Networking Cables

Description	Drive Connector	MMC-SD Control Connector	Part Number
CAT5e Patch Cord 0.3M	IN, OUT	C4	M.1302.8285
CAT5e Patch Cord 0.6M			M.1302.8286
CAT5e Patch Cord 1.0M			M.1302.8287
CAT5e Patch Cord 2.0M			M.1302.8288
CAT5e Patch Cord 3.0M			M.1302.8289
CAT5e Patch Cord 5.0M			M.1302.8300
CAT5e Patch Cord 10M			M.1302.8301
CAT5e Patch Cord 15M			M.1302.8302
CAT5e Patch Cord 30M			M.1302.8303

12.8 Connector Kits

Description	Part Number
CONN-FBK-12POS-16-28AWG	M.1302.0500
CONN-FBK-17POS-16-28AWG	M.1302.0510
CONN-PWR-BRK-8POS-14-16AWG-SIZE 1	M.1302.0479
CONN-PWR-BRK-8POS-12AWG-SIZE 1	M.1302.8755
CONN-PWR-BRK-8POS-12-14AWG-SIZE 1.5	M.1302.1998
CONN-PWR-BRK-8POS-8-10AWG-SIZE 1.5	M.1302.2354
CONN-PWR-BRK-8POS-6AWG-SIZE 3	M.1302.7492
CONN-PWR-BRK-8POS-4AWG-SIZE 3	M.1302.7493
CONN-PWR-FAN-6POS-16AWG	M.1302.6219
CONN-X100-X101	M.1302.7099
CONN-4TERM-MAINS	M.1302.7158
CONN-4TERM-MOTOR	M.1302.7159

12.9 Breakout Boards and Cables

12.9.1 Drive Mounted Breakout Boards

Description	Drive Connector	Part Number
BKOUT BD, F1/F2 MMC-SD, DR MT	F1, F2	M.1302.6970
BKOUT BD, I/O MMC-SD, DR MT	IO	M.1302.6971
BKOUT BD, C5 MMC-SD, DR MT	C5	M.1302.8480

12.9.2 Panel Mounted Breakout Boards

Description	Drive Connector	MMC-SD Control Connector	Part Number
BKOUT BD, F1/F2 MMC-SD, PNL MT	F1, F2		M.1302.6972
BKOUT BD, DRIVE I/O MMC-SD, PNL MT	IO		M.1302.6973
BKOUT BD, GEN I/O MMC-SD CONTROL, PNL MT		C5	M.1302.8253
BKOUT BD, BLOCK I/O MMC-SD CONTROL, PNL MT		C1	M.1016.2533
BKOUT BD, USER SERIAL MMC-SD CONTROL, PNL MT		C3	M.1016.2530

12.9.3 Breakout Board Kits

Description	Drive Connector	Part Number
KIT, BKOUT BD, F1/F2 MMC-SD 1.0M	F1, F2	M.1302.7005
KIT, BKOUT BD, F1/F2 MMC-SD 3.0M		M.1302.7006
KIT, BKOUT BD, F1/F2 MMC-SD 9.0M		M.1302.7007
KIT, BKOUT BD, F1/F2 MMC-SD 15.0M		M.1302.7008
KIT, BKOUT BD, I/O MMC-SD 1.0M	IO	M.1302.7009
KIT, BKOUT BD, I/O MMC-SD 3.0M		M.1302.7030
KIT, BKOUT BD, I/O MMC-SD 9.0M		M.1302.7031

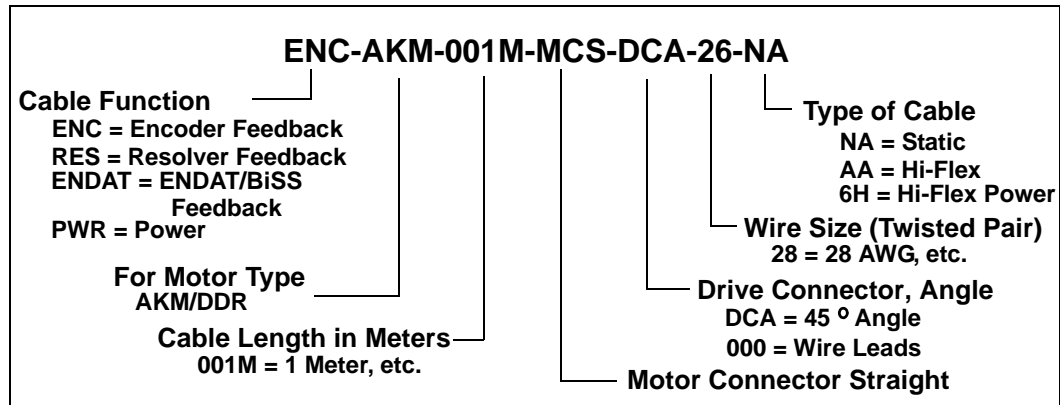
12.9.4 Breakout Board Cables

Description	Drive Connector	MMC-SD Control Connector	Part Number
CABLE, MMC-SD Feedback Port to Breakout Board, 1 Meter	F1, F2		M.1302.6976
CABLE, MMC-SD Feedback Port to Breakout Board, 3 Meter			M.1302.6977
CABLE, MMC-SD Feedback Port to Breakout Board, 9 Meter			M.1302.6979
CABLE, MMC-SD Feedback Port to Breakout Board, 15 Meter			M.1302.6980
CABLE, MMC-SD Drive I/O Port to Breakout Board, 1 Meter	IO		M.1302.6982
CABLE, MMC-SD Drive I/O Port to Breakout Board, 3 Meter			M.1302.6984
CABLE, MMC-SD Drive I/O Port to Breakout Board, 9 Meter			M.1302.6985
CABLE, MMC Control General I/O Port to Breakout Board, 1 Meter		C5	M.1302.8254
CABLE, MMC Control General I/O Port to Breakout Board, 3 Meter			M.1302.8255
CABLE, MMC Control General I/O Port to Breakout Board, 9 Meter			M.1302.8256
CABLE, MMC Control User Serial Port to Breakout Board, 1 Foot		C3	M.1016.2715
CABLE, MMC Control User Serial Port to Breakout Board, 2 Foot			M.1016.2716
CABLE, MMC Control User Serial Port to Breakout Board, 3 Foot			M.1016.2717
CABLE, MMC Control Block I/O Port to Breakout Board, 1 Foot		C1	M.1016.2543
CABLE, MMC Control Block I/O Port to Breakout Board, 2 Foot			M.1016.2544
CABLE, MMC Control Block I/O Port to Breakout Board, 3 Foot			M.1016.2545

12.9.5 Flying Lead Cables

Description	Drive Connector	MMC-SD Control Connector	Part Number
CABLE, MMC-SD Drive Feedback Port to Flying Lead, 10 Feet	F1, F2		M.1016.2519
CABLE, MMC-SD Drive I/O Port to Flying Lead, 1 Meter	IO		M.1302.7032
CABLE, MMC-SD Drive I/O Port to Flying Lead, 3 Meter			M.1302.7034
CABLE, MMC-SD Drive I/O Port to Flying Lead, 9 Meter			M.1302.7035
CABLE, MMC-SD Drive I/O Port to Flying Lead, 15 Meter			M.1302.7036
CABLE, MMC-SD Drive I/O Port to Flying Lead, 30 Meter			M.1302.7037
CABLE, MMC-SD Control General I/O Port to Flying Lead, 1 Meter			
CABLE, MMC-SD Control General I/O Port to Flying Lead, 3 Meter	M.1302.8258		
CABLE, MMC-SD Control General I/O Port to Flying Lead, 9 Meter	M.1302.8259		
CABLE, MMC-SD Control General I/O Port to Flying Lead, 15 Meter	M.1302.8290		
CABLE, MMC-SD Control General I/O Port to Flying Lead, 30 Meter	M.1302.8291		
CABLE, MMC-SD Control User Serial Port to Flying Lead, 10 Feet		C3	M.1016.2565
CABLE, MMC-SD Control Block I/O Port to Flying Lead, 10 Feet		C1	M.1016.2568

12.10 Motor Cables (AKM/DDR Motors)



12.10.1 Feedback Cables (AKM/DDR Motors)

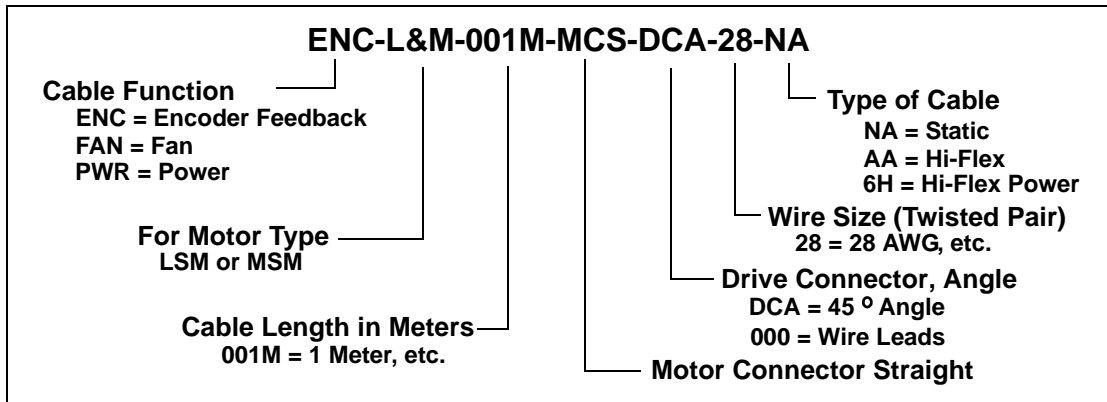
Feedback Cable	Part Number
Static Type	
ENC-AKM-001M-MCS-DCA-28-NA	M.1302.8590
ENC-AKM-003M-MCS-DCA-28-NA	M.1302.8447
ENC-AKM-006M-MCS-DCA-28-NA	M.1302.8591
ENC-AKM-009M-MCS-DCA-28-NA	M.1302.8542
ENC-AKM-015M-MCS-DCA-28-NA	M.1302.8594
ENC-AKM-030M-MCS-DCA-28-NA	M.1302.8595
RES-AKM-001M-MCS-DCA-28-NA	M.1302.8618
RES-AKM-003M-MCS-DCA-28-NA	M.1302.8439
RES-AKM-006M-MCS-DCA-28-NA	M.1302.8619
RES-AKM-009M-MCS-DCA-28-NA	M.1302.8620
RES-AKM-015M-MCS-DCA-28-NA	M.1302.8621
RES-AKM-030M-MCS-DCA-28-NA	M.1302.8622
ENDAT-AKM-001M-MCS-DCA-28-NA	M.1302.8605
ENDAT-AKM-003M-MCS-DCA-28-NA	M.1302.8437
ENDAT-AKM-006M-MCS-DCA-28-NA	M.1302.8606
ENDAT-AKM-009M-MCS-DCA-28-NA	M.1302.8607
ENDAT-AKM-015M-MCS-DCA-28-NA	M.1302.8608
ENDAT-AKM-030M-MCS-DCA-28-NA	M.1302.8609

Flexing Type (12 X O.D. Min Bend Radius)	
ENC-AKM-001M-MCS-DCA-28-AA	M.1302.8600
ENC-AKM-003M-MCS-DCA-28-AA	M.1302.8435
ENC-AKM-006M-MCS-DCA-28-AA	M.1302.8601
ENC-AKM-009M-MCS-DCA-28-AA	M.1302.8602
ENC-AKM-015M-MCS-DCA-28-NA	M.1302.8603
ENC-AKM-030M-MCS-DCA-28-NA	M.1302.8604
RES-AKM-001M-MCS-DCA-28-NA	M.1302.8630
RES-AKM-003M-MCS-DCA-28-NA	M.1302.8450
RES-AKM-006M-MCS-DCA-28-NA	M.1302.8631
RES-AKM-009M-MCS-DCA-28-NA	M.1302.8632
RES-AKM-015M-MCS-DCA-28-NA	M.1302.8633
RES-AKM-030M-MCS-DCA-28-NA	M.1302.8634
ENDAT-AKM-001M-MCS-DCA-28-NA	M.1302.8613
ENDAT-AKM-003M-MCS-DCA-28-NA	M.1302.8438
ENDAT-AKM-006M-MCS-DCA-28-NA	M.1302.8614
ENDAT-AKM-009M-MCS-DCA-28-NA	M.1302.8615
ENDAT-AKM-015M-MCS-DCA-28-NA	M.1302.8616
ENDAT-AKM-030M-MCS-DCA-28-NA	M.1302.8617

12.10.2 Motor Power Cables (AKM/DDR Motors)

Power Cable (Flexing Type, 12 X O.D. Min Bend Radius)	Part Number
PWR-AKM-001M-MCS-000-14-6H	M.1302.8585
PWR-AKM-003M-MCS-000-14-6H	M.1302.8549
PWR-AKM-006M-MCS-000-14-6H	M.1302.8586
PWR-AKM-009M-MCS-000-14-6H	M.1302.8554
PWR-AKM-015M-MCS-000-14-6H	M.1302.8588
PWR-AKM-030M-MCS-000-14-6H	M.1302.8589

12.11 Motor Cables (LSM/MSM Motors)



12.11.1 Feedback Cables (LSM/MSM Motors)

Feedback Cable	Part Number
Static Type	
ENC-L&M-001M-MCS-DCA-28-NA	M.1302.0944
ENC-L&M-003M-MCS-DCA-28-NA	M.1302.0945
ENC-L&M-009M-MCS-DCA-28-NA	M.1302.0946
ENC-L&M-015M-MCS-DCA-28-NA	M.1302.0947
ENC-L&M-030M-MCS-DCA-28-NA	M.1302.0948
Flexing Type (12 X O.D. Min Bend Radius)	
ENC-L&M-001M-MCS-DCA-28-AA	M.1302.5834
ENC-L&M-003M-MCS-DCA-28-AA	M.1302.5835
ENC-L&M-009M-MCS-DCA-28-AA	M.1302.5836
ENC-L&M-015M-MCS-DCA-28-AA	M.1302.5837
ENC-L&M-030M-MCS-DCA-28-AA	M.1302.5838

12.11.2 Power Cables for Blower Fan (LSM/MSM Motors)

Power Cable	Part Number
FAN-L&M-001M-MCS-000-16	M.1302.6310
FAN-L&M-003M-MCS-000-16	M.1302.6311
FAN-L&M-009M-MCS-000-16	M.1302.6312
FAN-L&M-015M-MCS-000-16	M.1302.6313
FAN-L&M-030M-MCS-000-16	M.1302.6314

12.11.3 Motor Power Cables (LSM/MSM Motors)

Power Cable (Flexing Type, 12 X O.D. Min Bend Radius)	Part Number
PWR-L&M-001M-MCS-000-16-6H	M.1302.1114
PWR-L&M-003M-MCS-000-16-6H	M.1302.1115
PWR-L&M-009M-MCS-000-16-6H	M.1302.1116
PWR-L&M-015M-MCS-000-16-6H	M.1302.1117
PWR-L&M-030M-MCS-000-16-6H	M.1302.1118
PWR-L&M-001M-MCS-000-14-6H	M.1302.1119
PWR-L&M-003M-MCS-000-14-6H	M.1302.1130
PWR-L&M-009-MCS-000-14-6H	M.1302.1131
PWR-L&M-015M-MCS-000-14-6H	M.1302.1132
PWR-L&M-030M-MCS-000-14-6H	M.1302.1133
PWR-L&M-001M-MCS-000-12-6H	M.1302.1134
PWR-L&M-003M-MCS-000-12-6H	M.1302.1135
PWR-L&M-009M-MCS-000-12-6H	M.1302.1136
PWR-L&M-015M-MCS-000-12-6H	M.1302.1137
PWR-L&M-030M-MCS-000-12-6H	M.1302.1139
PWR-L&M-001M-MCS-000-10-6H	M.1302.1140
PWR-L&M-003M-MCS-000-10-6H	M.1302.1142
PWR-L&M-009M-MCS-000-10-6H	M.1302.1143
PWR-L&M-015M-MCS-000-10-6H	M.1302.1144
PWR-L&M-030M-MCS-000-10-6H	M.1302.1145

PWR-L&M-001M-MCS-000-08-6H	M.1302.1146
PWR-L&M-003M-MCS-000-08-6H	M.1302.1147
PWR-L&M-009M-MCS-000-08-6H	M.1302.1148
PWR-L&M-015M-MCS-000-08-6H	M.1302.1149
PWR-L&M-030M-MCS-000-08-6H	M.1302.1150
PWR-L&M-001M-MCS-000-06-6H	M.3000.tbd
PWR-L&M-003M-MCS-000-06-6H	M.3000.tbd
PWR-L&M-009M-MCS-000-06-6H	M.3000.tbd
PWR-L&M-015M-MCS-000-06-6H	M.3000.tbd
PWR-L&M-030M-MCS-000-06-6H	M.3000.tbd
PWR-L&M-001M-MCS-000-04-6H	M.3000.tbd
PWR-L&M-003M-MCS-000-04-6H	M.3000.tbd
PWR-L&M-009M-MCS-000-04-6H	M.3000.tbd
PWR-L&M-015M-MCS-000-04-6H	M.3000.tbd
PWR-L&M-030M-MCS-000-04-6H	M.3000.tbd
PWR-L&M-001M-MCS-000-02-6H	M.3000.tbd
PWR-L&M-003M-MCS-000-02-6H	M.3000.tbd
PWR-L&M-009M-MCS-000-02-6H	M.3000.tbd
PWR-L&M-015M-MCS-000-02-6H	M.3000.tbd
PWR-L&M-030M-MCS-000-02-6H	M.3000.tbd

12.12 Optional External Devices

12.12.1 AC Line Filters

For Drive Model	AC Line Filter Description	Part Number
MMC-SD-0.5-230(-D) MMC-SD-1.0-230(-D)	6A, 250V, Single phase	M.1015.6922
MMC-SD-2.0-230(-D)	10A, 250V, Single phase,	M.1015.6917
MMC-SD-1.3-460(-D) MMC-SD-2.4-460(-D)	7A, 480V, Three phase	M.1302.5241
MMC-SD- 4.0-460(-D) MMC-SD-6.0-460(-D) MMC-SD- 8.0-460(-D)	16A, 480V, Three phase	M.1302.5244
MMC-SD-12.0-460(-D) MMC-SD-16.0-460(-D)	30A, 480V, Three phase	M.1302.5245
MMC-SD-24.0-460(-D)	42A, 480V, Three phase	M.1302.5246
MMC-SD-30.0-460-D MMC-SD-42.0-460-D	56A, 480V, Three phase	M.1302.5247
MMC-SD-51.0-460-D	75A, 480V, Three phase	M.1302.5248
MMC-SD-65.0-460-D	100A, 480V, Three phase	M.3000.0019

12.12.2 AC Line Reactors

Drive Model	Required Line Reactor (Amps)	Power Loss (Watts)	Inductance (mH)	Weight (Pounds)	Part Number
MMC-SD-12.0-460(-D)	25	52	1.2	14	M.1302.7373
MMC-SD-16.0-460(-D)	35	54	0.8	16	M.1302.7374
MMC-SD-24.0-460(-D)	45	62	0.7	28	M.1302.7375
MMC-SD-30.0-460-D	55	67	0.5	27	M.3000.0105
MMC-SD-42.0-460-D	80	86	0.4	51	M.3000.0106
MMC-SD-51.0-460-D	100	84	0.3	51	M.3000.0107
MMC-SD-65.0-460-D	130	180	0.2	57	M.3000.0108

12.12.3 External Shunt Resistor Kits

For Drive	Shunt Resistor Module	Part Number
MMC-SD-0.5-230(-D) MMC-SD-1.0-230(-D) MMC-SD-2.0-230(-D)	100Ω, 300W, 600V, Dynamic	M.1015.7046
MMC-SD-1.3-460(-D) MMC-SD-2.4-460(-D)	130Ω, 450W Cont. Power, 5.4kW Peak Power, 820V, 240 sec. Time Constant, 121 mm x 93 mm x 605 mm	M.1302.7048
MMC-SD-4.0-460(-D)	95Ω, 700W Cont. Power, 8kW Peak Power, 820V, 250 sec. Time Constant, 121 mm x 93 mm x 705 mm	M.1302.7049
MMC-SD-6.0-460(-D) MMC-SD-8.0-460(-D)	50Ω, 1400W Cont. Power, 17kW Peak Power, 850V, 250 sec. Time Constant, 130 mm x 182 mm x 710 mm	M.1302.7060
MMC-SD-12.0-460(-D) MMC-SD-16.0-460(-D)	25Ω, 2800 W Cont. Power, 32kW Peak Power, 850V, 60 sec. Time Constant, 71 mm x 430 mm x 550 mm	M.1302.7061
MMC-SD-24.0-460(-D) MMC-SD-30.0-460-D MMC-SD-42.0-460-D MMC-SD-51.0-460-D MMC-SD-65.0-460-D	18Ω, 3900W Cont. Power, 70kW Peak Power, 850V, 70 sec. Time Constant, 180 mm x 445 mm x 490 mm	M.1302.7063

12.13 Software

Description	Part Number
PiCPro Professional Edition	M.1300.7213
PiCPro MMC Limited Edition	M.1300.7214
PiCPro Monitor Edition	M.1300.7215

13 Declarations of Conformity

EC DECLARATION OF CONFORMITY

The undersigned, representing the supplier

G & L Motion Control Inc.
672 South Military Road
Fond du Lac, Wisconsin 54936-1960

herewith declares that all **three-phase current synchronous motors, type LSM** are in conformity with the provisions of the following EC Directive when installed in accordance with the installation instructions contained in the product documentation:

Low Voltage Directive 73/23 EWG

Conformity of the specified product with the guidelines of this directive will be proved by the total compliance with the following harmonic European standards:

EN 60034-1: September 2000 Rotating Electrical Machines
+A11 May 2002
EN 60034-5: December 2001
EN 60034-9: June 1998

Year of Marking: 2002

<i>Signature</i>	<i>Robert J. Kollmeyer</i>
<i>Full Name</i>	Robert J. Kollmeyer
<i>Position</i>	Director of Engineering
<i>Place</i>	G & L Motion Control Inc.
<i>Date</i>	<i>05 - APR - 05</i>

EC DECLARATION OF CONFORMITY

The undersigned, representing the supplier

G & L Motion Control Inc.
672 South Military Road
Fond du Lac, Wisconsin 54936-1960

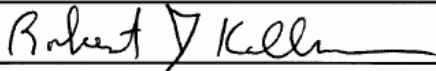
herewith declares that all **three-phase current synchronous motors, type MSM** are in conformity with the provisions of the following EC Directive when installed in accordance with the installation instructions contained in the product documentation:

Low Voltage Directive 73/23 EWG

Conformity of the specified product with the guidelines of this directive will be proved by the total compliance with the following harmonic European standards:

EN 60034-1: November 1995 Rotating Electrical Machines
EN 60034-5: April 1998
EN 60034-9: May 1996

Year of Marking: 1999

<i>Signature</i>	
<i>Full Name</i>	Robert J. Kollmeyer
<i>Position</i>	Director of Engineering
<i>Place</i>	G & L Motion Control Inc.
<i>Date</i>	05 - APR - 05

The undersigned, representing the supplier

G & L Motion Control Inc.
672 South Military Road
Fond du Lac, Wisconsin 54936-1960

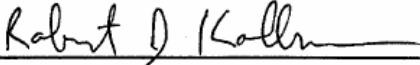
herewith declares that all **PiC900™/PiC90™/PiC9™/MMC and Block I/O modules**, labeled with the CE mark, are in conformity with the provisions of the following EC Directives when installed in accordance with the installation instructions contained in the product documentation:

Low Voltage Directive 73/23/EEC as amended by 93/68/EEC
EMC Directive 89/336/EEC as amended by 92/31/EEC and 93/68/EEC

Conformity of the specified product is based upon application of the following standards and/or technical specifications referenced below:

<i>EN 50081-2:1993</i>	<i>EMC Generic Industrial Emissions</i>
<i>EN 50082-2:1995</i>	<i>EMC Generic Industrial Immunity</i>
<i>EN 61131-2:1994/A11:1996</i>	<i>Low voltage requirements for programmable controllers</i>
<i>EN61326:1997</i>	<i>Electrical Equipment for measurement, control and Laboratory use – EMC requirements</i>

Year of Marking: 2002

<i>Signature</i>	
<i>Full Name</i>	Robert J. Kollmeyer
<i>Position</i>	Director of Engineering
<i>Place</i>	G & L Motion Control Inc.
<i>Date</i>	05-APR-05

EC DECLARATION OF CONFORMITY

The undersigned, representing the supplier

G & L Motion Control Inc.
672 South Military Road
Fond du Lac, Wisconsin 54936-1960

herewith declares that all **servo drives and accessories** (see attached list of catalogue numbers) are in conformity with the provisions of the following EC Directive(s) when installed in accordance with the installation instructions contained in the product documentation:

Low Voltage Directive as amended by 93/68/EEC

EMC Directive as amended by 92/31/EEC and 93/68/EEC

and that the standards and/or technical specifications referenced below have been applied:

*EN 60034-1:1998 +
A1:1998 and A2:1999*

*Rotating Electrical Machines
Part 1: Rating and Performance*

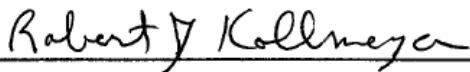
EN 60204-1:1997

*Safety of machinery – Electrical equipment of machines
Part 1: Specifications for general requirements*

EN 61800-3:1996

*Adjustable Speed Electrical Power Drive Systems – EMC
Product Standard Including Specific Test Methods*

Year of Marking: 2002

<i>Signature</i>	
<i>Full Name</i>	Robert J. Kollmeyer
<i>Position</i>	Director of Engineering
<i>Place</i>	G & L Motion Control Inc.
<i>Date</i>	05-APR-05

EC DECLARATION OF CONFORMITY

The undersigned, representing the supplier

G & L Motion Control Inc.
672 South Military Road
Fond du Lac, Wisconsin 54936-1960


herewith declares that all MMC Smart Drives (**MMC-SD-XXX-XXX-XXX**) and accessories, and all **S200-DLS Drives**, labeled with the CE mark, are in conformity with the provisions of the following EC Directive(s) when installed in accordance with the installation instructions contained in the product documentation:

73/23/EEC *Low Voltage Directive as amended by 93/68/EEC*
89/336/EEC *EMC Directive as amended by 92/31/EEC and 93/68/EEC*

and that the standards and/or technical specifications referenced below have been applied:

EN 50178:1998 *Electronic equipment for use in power installations*
EN 61800-3:1996 *Adjustable speed electrical power drive systems - EMC*
/A11:2000 *Product standard including specific test methods*

Year of Marking: 2003

Signature	
Full Name	Peter Winkelmann
Position	Business Unit Manager
Place	G & L Motion Control Inc.
Date	10 MAR 09

Appendix A - 460V MMC Smart Drive DC Bus Sharing

A.1 Introduction

This section discusses DC bus sharing among 2 or more 460V Smart Drives.

DC bus sharing accomplishes 4 things:

- It pools the capacitance of all of the drives.
- It lowers electricity cost.
- It allows multiple drives to share one shunt resistor.
- It allows the shunt energy to be shared among multiple shunt resistors.

Pooling the capacitance increases the Joule energy absorption capability to the sum of the drives connected ([Table A-2 on page 264](#)). This lowers energy cost slightly because energy that can be absorbed is not wasted in the shunt resistors. In some applications, this can eliminate the need for a shunt resistor altogether.

Many applications will have one drive motoring while the other is regenerating. This energy is transferred from one drive to the other through the DC bus rather than being dissipated in a shunt. This saves energy cost.

If it is desired to share one shunt resistor instead of using one per drive, the energy flows through the DC bus to the drive controlling the shunt resistor. Its internal circuitry will turn the shunt on when the bus voltage reaches an upper limit.

If it is desired to distribute the shunt load among multiple drives, each having a smaller resistor, then **it is important to interconnect the “Shunt On” signals for all drives sharing the DC bus**. This ensures that all of the shunt resistors will properly share the load. If this connection is not made, it is likely that only one shunt resistor will dissipate all of the shunt power, overheating it.

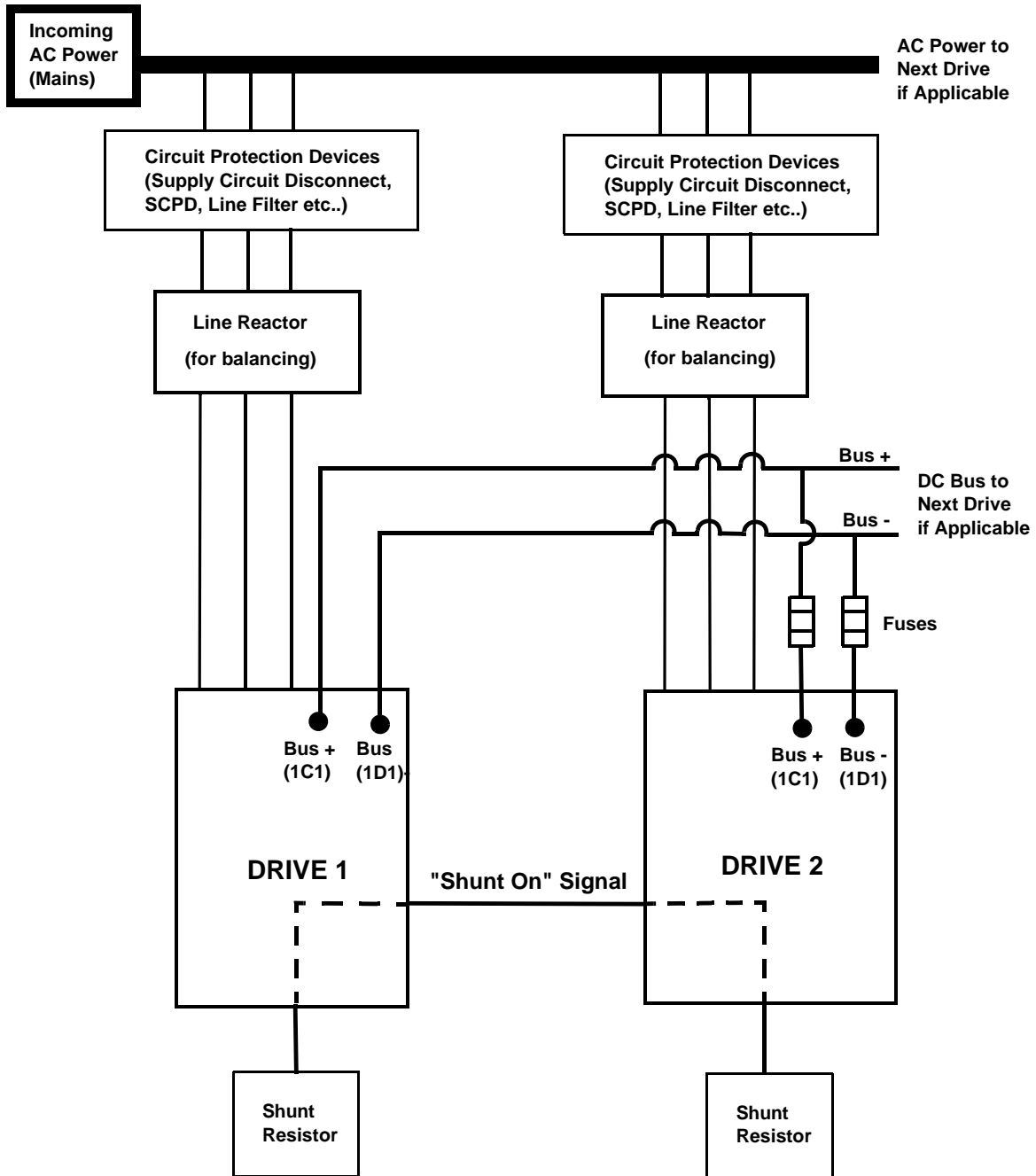
A.2 DC Bus Sharing with AC Power to All Drives

When sharing DC power among several drives with AC power supplying all of the drives ([Figure A-1](#)), all drives must be the same size (for example, all drives must be MMC-SD-4.0-460). When two drives are connected to a shared DC bus in this manner, the combined energy absorption of all drives is available.

3% line reactors are required for all sizes using this configuration to ensure rectifier balance. However, shunt resistors are optional (see below). Refer to Chapter 4 in this manual for information related to fusing, line reactors and shunts. Refer to Chapter 6 for connector information.

When more than one shunt is used with the MMC Smart Drives, it is important to tie the “Shunt On” circuits together so that all shunts get turned on at the same time. For example, in [Figure A-1](#), if the shunt connected to Drive 1 turns on, the “Shunt On” signal will turn on the shunt for Drive 2. The second shunt resistor is optional as long as the “Shunt On” signal is connected as shown. The “Shunt On” signal acts as both an input and an output for each Drive.

Figure A-1: DC Bus Sharing with AC Input Power to All Drives



A.3 DC Bus Sharing with AC Power to One Drive

When sharing DC power among several drives with AC power supplying just one of the drives ([Figure A-2](#)), all drives need not be the same size (for example, one drive may be a MMC-SD-8.0-460, and another drive may be a MMC-SD-1.3-

460). When two or more drives are connected to a shared DC bus in this manner, there are two limits that must be considered:

- The drives not powered by AC must not consume more power than the “Bus power available for linking to other drives” as listed in [Table A-1](#).
- The total power consumed by all drives cannot exceed the greater of “Bus power available for linking to other drives” and the kW rating of the AC powered drive as listed in [Table A-1](#).

For example, assume that the AC powered drive is a MMC-SD-24.0-460 and consumes 14kW, and supplies DC power to two more drives that consume 4kW each (8kW total). From [Table A-1](#), the total DC power available to the non-AC powered drives is 10kW, meeting the first criteria. The total power consumed is 22kW, and since the AC powered drive is a 24kW drive, meets the second criteria.

The continuous current available from the drive would be reduced by the same percentage as the kW. In the example given, the available kW was reduced from 24 to 16kW. Therefore $16/24 = 67\%$. The drive’s continuous current is reduced by 1/3 from 45 Amps to 30 Amps.

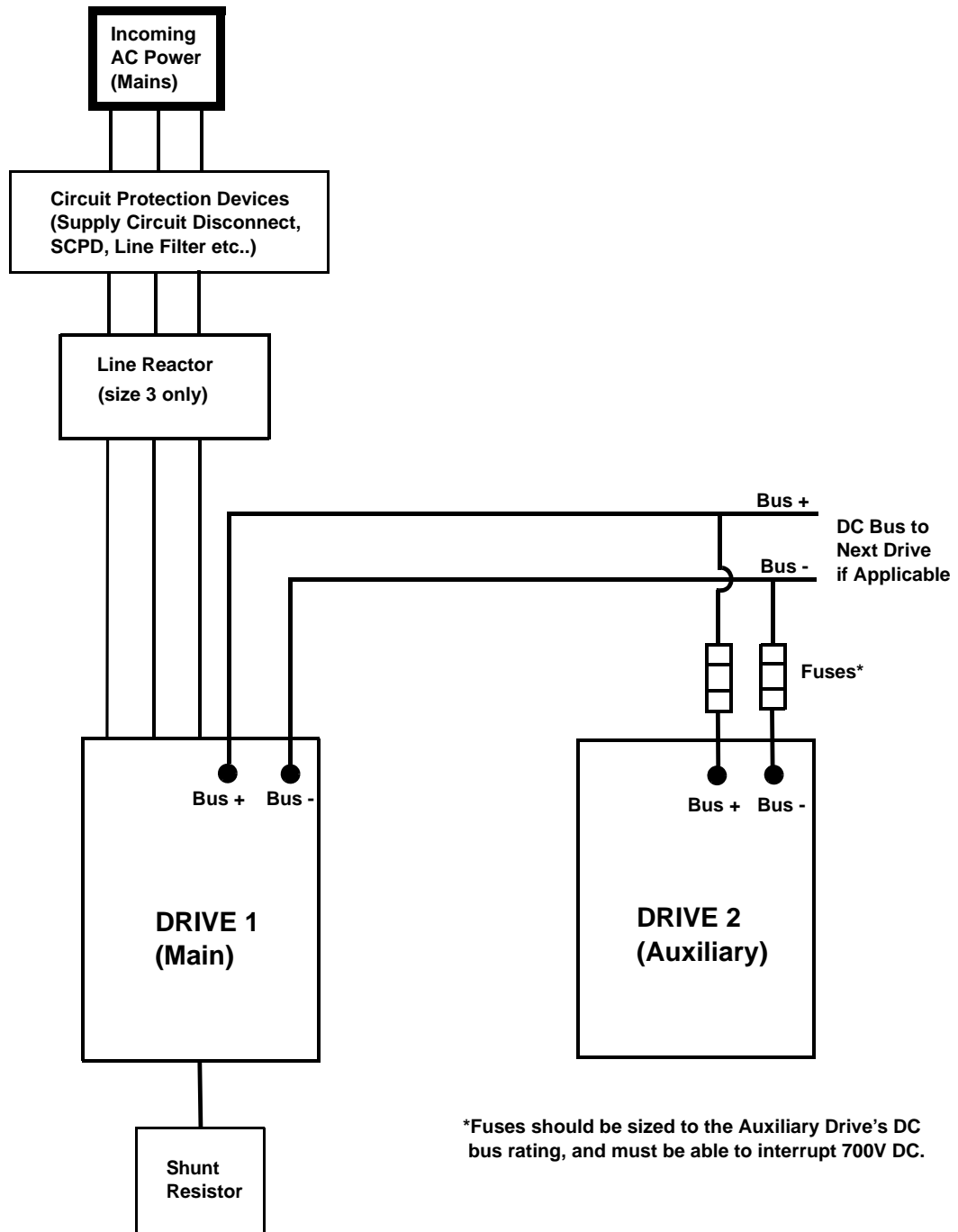
If peak current is to be used at the same time on more than one drive, the total peak current used by all drives must not exceed that of the main drive. If both the main and auxiliary drives will accelerate at the same time, the peak current used by auxiliary drives is subtracted from the available peak current of the main drive. Connection of a shunt to the main drive is optional depending on the results found in sizing the system. The system will have the combined DC Bus capacitance of all drives connected.

[Table A-2 on page 264](#) shows the MMC Smart Drive bus capacitance and energy absorption capability.

:

Table A-1: kW Ratings for Powered Drive			
Drive Model	Bus power available for linking to other drives	Continuous Current (Amps)	Peak Current (Amps)
MMC-SD-1.3-460	2.0kW	3	6
MMC-SD-2.4-460	2.0kW	5.5	11
MMC-SD-4.0-460	5.0kW	9	18
MMC-SD-6.0-460	5.0kW	13.5	27
MMC-SD-8.0-460	5.0kW	18	36
MMC-SD-12.0-460	10.0kW	27.5	55
MMC-SD-16.0-460	10.0kW	36.5	73
MMC-SD-24.0-460	10.0kW	55	110
MMC-SD-30.0-460	10.0kW	69.3	110
MMC-SD-42.0-460	36.0kW	93.3	147
MMC-SD-51.0-460	45.0kW	117.4	184
MMC-SD-65.0-460	58.0kW	152.7	209

Figure A-2: Two or more drives with AC input power to one drive



*Fuses should be sized to the Auxiliary Drive's DC bus rating, and must be able to interrupt 700V DC.

Table A-2: Drive Bus Capacitance and energy Absorption Capability

Drive ^a	MMC Smart Drive Bus Capacitance (μFarad)	Energy Absorption at 230V Line Input and 230V Motor (Joules)	Energy Absorption at 230V Line Input and 460V Motor (Joules)	Energy Absorption at 460V Line Input and 460V Motor (Joules)
460V Size 1				
MMC-SD-1.3-460	110	3	28	10
MMC-SD-2.4-460	240	7	60	22
460V Size 2				
MMC-SD-4.0-460	470	13	118	44
MMC-SD-6.0-460	470	13	118	44
MMC-SD-8.0-460	705	19	177	66
460V Size 3				
MMC-SD-12.0-460	820	22	206	76
MMC-SD-16.0-460	1230	33	309	114
MMC-SD-24.0-460	1640	45	412	152
MMC-SD-30.0-460	2000	55	502	185
460V Size 4				
MMC-SD-42.0-460	1880	50.4	472	173
MMC-SD-51.0-460	2350	63.1	591	218
MMC-SD-65.0-460	3055	82	768	284
230 V^b				
MMC-SD-0.5-460	1410	38		
MMC-SD-1.0-460	1880	51		
MMC-SD-2.0-460	1880	51		

a. add suffix (-D) for Digital Drive

b. add suffix (-D) for Digital Drives and (-DN) for Digital Narrow Drives

Index

Numerics

230V Smart Drive
 24VDC IN/Brake connector [96](#)
 address switches [68](#), [69](#)
 dimensions [103](#)
 drive I/O connector [89](#)
 F1/F2 feedback connectors [71](#)
 LEDs [63](#)
 motor connector [98](#)
 PiCPro port (analog drive) [65](#)
 PiCPro port (digital drive) [63](#)
 specifications [99](#)

24V power connector
 460V Smart Drive
 size 1 [113](#)
 size 2 [118](#)
 size 3 [123](#)
 size 4 [128](#)

24VDC IN/Brake connector
 230V Smart Drive [96](#)

460V Smart Drive
 24V power connector
 size 1 [113](#)
 size 2 [118](#)
 size 3 [123](#)
 size 4 [128](#)

AC power connector
 size 1 [112](#)
 size 2 [116](#)
 size 3 [121](#)
 size 4 [126](#)

address switches [68](#), [69](#)

connectors
 size 1 [109](#)
 size 2 [114](#)
 size 3 [119](#)
 size 4 [124](#)

dimensions [143](#)
 drive connection layout [131](#)
 drive I/O connector [89](#)
 F1/F2 feedback connectors [71](#)

fan connector
 size 4 [130](#)

motor brake connector
 size 1 [114](#)
 size 2 [119](#)
 size 3 [124](#)
 size 4 [129](#)

motor connector
 size 1 [112](#)
 size 2 [117](#)

size 3 [122](#)
 size 4 [127](#)
 part numbers [234](#)
 PiCPro port (analog drive) [65](#)
 PiCPro port (digital drive) [63](#)
 shunt/DC bus connector
 size 1 [111](#)
 specifications [132](#)

A

AC line filters
 part numbers [251](#)

AC line reactors
 part numbers [251](#)

AC power connector
 460V Smart Drive
 size 1 [112](#)
 size 2 [116](#)
 size 3 [121](#)
 size 4 [126](#)

address switches
 230V Smart Drive [68](#), [69](#)
 460V Smart Drive [68](#), [69](#)
 S200-DLS Drive [153](#)

AKM/DDR motor cables
 part numbers [244](#)

application
 wiring [25](#)

Auxiliary Feedback Port
 S200-DLS Drive [157](#)

B

block I/O port
 Drive Resident MMC Control [209](#)

bonding
 mounting [20](#)

breakout boards & cables
 part numbers [241](#)

C

cables
 pin assignments
 LSM and MSM motors [174](#)

CE
 filter requirements [24](#)

combination fuse
 part numbers [237](#)

conformity
 european directives [18](#)
 UL and cUL standards [18](#)

connecting
 Drive Resident MMC Control [205](#)

connections

- Drive Resident MMC Control [209](#)
- connector kits
 - part numbers [240](#)
- connectors
 - 460V Smart Drive
 - size 1 [109](#)
 - size 2 [114](#)
 - size 3 [119](#)
 - size 4 [124](#)
- contents of the manual [9](#)
- control cabinet
 - requirements [21](#)

D

- DC input operation
 - Drive Resident MMC Control [228](#)
- DC output operation
 - Drive Resident MMC Control [226](#)
- diagnostic
 - error codes [185](#), [192](#)
- Diagnostic Indicator
 - S200-DLS Drive [153](#)
- diagnostics
 - Drive Resident MMC Control [206](#)
 - power on [184](#)
 - runtime [185](#)
- Digital Link
 - LEDs [153](#)
- digital link cables
 - part numbers [239](#)
- digital link option card
 - S200-DLS Drive [153](#)
- Digital Link Ports
 - S200-DLS Drive [155](#)
- dimensions
 - 230V Smart Drive [103](#)
 - 460V Smart Drive [143](#)
 - cabinet clearance [19](#)
 - motor cable [31](#)
 - shunts [50](#)
- distribution
 - power [28](#)
- drive connection layout
 - 460V Smart Drive [131](#)
- drive I/O connector
 - 230V Smart Drive [89](#)
 - 460V Smart Drive [89](#)
- Drive I/O Port details
 - S200-DLS Drive [164](#)
- Drive Resident MMC Control
 - block I/O port [209](#)
 - connecting [205](#)
 - connections [209](#)
 - DC input operation [228](#)

- DC output operation [226](#)
- diagnostics [206](#)
- error codes [208](#)
- ethernet port [219](#)
- front view [202](#)
- general I/O port [221](#)
- overview [201](#)
- part numbers [238](#)
- PiCPro port [209](#)
- power LED [206](#)
- run-time diagnostics [208](#)
- scan LED [206](#)
- setup and maintenance [205](#)
- specifications [230](#)
- starting an operation [205](#)
- startup diagnostic LED [207](#)
- system wiring guidelines [204](#)
- troubleshooting [206](#)
- user port [213](#)

E

- electrical service & maintenance safety [14](#)
- EMI (ElectroMagnetic Interference)
 - bonding [20](#)
- error codes
 - diagnostic [185](#), [192](#)
 - drive fault [186](#), [192](#)
 - Drive Resident MMC Control [208](#)
- ethernet port
 - Drive Resident MMC Control [219](#)

F

- F1/F2 feedback connectors
 - 230V Smart Drive [71](#)
 - 460V Smart Drive [71](#)
- fan connector
 - 460V Smart Drive
 - size 4 [130](#)
- faults
 - diagnostic [185](#), [192](#)
- filter, AC power [24](#)
- front view
 - Drive Resident MMC Control [202](#)

G

- general I/O port
 - Drive Resident MMC Control [221](#)
- grounding
 - CE single phase 230V drive system [24](#)
 - multiple drives [25](#)
 - protective earth [12](#)
 - system [22](#)

H

handling the MMC Smart Drive [17](#)
 heat
 controlling [19](#)

I

I/O Power Port
 S200-DLS Drive [164](#)
 inspection
 safety [13](#)
 installation [18](#)
 installing [17](#)
 resolver option module [197](#)
 isolation transformers
 230V formula [48](#)
 460V formula [48](#)

L

LEDs
 230V Smart Drive [63](#)
 Digital Link on S200-DLS Drive [153](#)
 error codes [185](#), [192](#)
 S200-DLS drive option card [153](#)
 line filters
 block diagram for 3-phase [54](#)
 CE compliance [53](#)
 connection diagram for 3-phase [54](#)
 technical data
 230V [56](#)
 460V [57](#)
 LSM/MSM motor cables
 part numbers [248](#)

M

maintenance [183](#)
 manual cleaning procedure [15](#)
 MMC Control
 see Drive Resident MMC Control [201](#)
 MMC Smart Drive
 introduction [9](#)
 power [29](#)
 motor brake connector
 460V Smart Drive
 size 1 [114](#)
 size 2 [119](#)
 size 3 [124](#)
 size 4 [129](#)
 motor connector
 230V Smart Drive [98](#)
 460V Smart Drive
 size 1 [112](#)
 size 2 [117](#)
 size 3 [122](#)

 size 4 [127](#)
 mounting [21](#)
 bonding [20](#)

N

noise
 see bonding [20](#)

O

operation
 safety [14](#)
 overview
 Drive Resident MMC Control [201](#)

P

part numbers
 230V Smart Drive [233](#)
 460V Smart Drive [234](#)
 AC line filters [251](#)
 AC line reactors [251](#)
 AKM/DDR motor cables [244](#)
 breakout boards & cables [241](#)
 combination fuse [237](#)
 connector kits [240](#)
 digital link cables [239](#)
 drive connect cables [239](#)
 Drive Resident MMC Control [238](#)
 LSM/MSM motor cables [248](#)
 optional external devices [251](#)
 Resolver option module [238](#)
 resolver option modules [238](#)
 S200-DLS Drive [236](#)
 PicPro port
 Drive Resident MMC Control [209](#)
 PiCPro port (analog drive)
 230V Smart Drive [65](#)
 460V Smart Drive [65](#)
 PiCPro port (digital drive)
 230V Smart Drive [63](#)
 460V Smart Drive [63](#)
 power
 distribution in MMC [28](#)
 MMC Smart Drive [29](#)
 power LED
 Drive Resident MMC Control [206](#)
 procedure
 manual cleaning [15](#)
 protective earth
 grounding [12](#)

R

Requirements
 Transformer [35](#)

resolver option module
installing 197
part numbers 238
theory of operation 197
resolver option modules
part numbers 238
run-time diagnostics
Drive Resident MMC Control 208

S

S200-DLS Drive
address switches 153
Auxiliary Feedback Port 157
Diagnostic Indicator 153
Digital Link Option Card 153
Digital Link Ports 155
Drive I/O Port details 164
I/O Power Port details 164
introduction 151
LEDs 153
part numbers 236
specifications 169
safety
after shutdown 13
cleaning 15
electrical service & maintenance 14
inspection 13
operating safely 14
operation 14
signs 12
system 11
warning labels 12
Sales and Service 270
scan LED
Drive Resident MMC Control 206
Service 270
setup and maintenance
Drive Resident MMC Control 205
shields 26
shunt/DC bus connector
460V Smart Drive
size 1 111
shunts
choosing 48
dimensions 50
signs
safety 12
single point ground (SPG)
checklist 22
software
required 10
specifications
230V MMC Smart Drive 99

460V Smart Drive 132
Drive Resident MMC Control 230
optional resolver module 200
S200-DLS Drive 169
starting an operation
Drive Resident MMC Control 205
startup diagnostic LED
Drive Resident MMC Control 207
storage
before installation 17
storing the drive 17
system mounting requirements
ventilation 18
system wiring guidelines
Drive Resident MMC Control 204

T

technical support contacts 10
theory of operation
resolver option module 197
Transformer
Size 35
troubleshooting
drive error codes 186, 192
Drive Resident MMC Control 206
general 184
hardware wiring 184

U

Unpacking 17
user port
Drive Resident MMC Control 213

V

ventilation 18

W

warning label
danger, warning, caution 13
hazard 12
Web Address 270
wiring
application 25
connecting shunt modules 179
connections for 3-phase line filter 54
EMC compliant 25
interface cables 30
preparing motor connection wires 31
routing high/low voltage cables 30
terminating 230V motor power cable 32
terminating 460V power cable 33

Sales and Service

We are committed to quality customer service. In order to serve in the most effective way, please contact your local sales representative for assistance.

If you are unaware of your local sales representative, please contact us.

North America

Kollmorgen Customer Support North America

E-mail: glmotion.support@kollmorgen.com
Phone: In the United States, telephone (800) 558-4808
Outside the United States, telephone (920) 921-7100
Fax: (920) 906-7669
Web site: www.glcontrols.com

Europe

Kollmorgen Customer Support Europe

E-mail: glmotion.support@kollmorgen.com
Phone: +44 (0)1525 243-243
Fax: +44 (0)1525 243-244
Web site: www.glcontrols.com

KOLLMORGEN[®]

Because Motion Matters™