

---

Danaher Motion

# MMC Smart Drive<sup>™</sup> and Digital MMC Control

Hardware Manual  
Version 3.1



Keep all product manuals as a product component during the life span of the product.  
Pass all product manuals to future users/owners of the product.

Catalog No. M.1301.5524  
Part No. M.3000.0525



**Record of Revisions**

<b>Edition</b>	<b>Valid for</b>	<b>Description</b>
03/2007	PiCPro V16.1	Major Update
10/2007	PiCPro V16.1 SP2	Added MMC-D8

Third party brands and trademarks are the property of their respective owners

Technical changes to improve the performance of the equipment may be made without notice!  
Printed in USA  
All rights reserved. No part of this work may be reproduced in any form (by printing, photocopying, microfilm or any other method) or processed, copied or distributed by electronic means without the written permission of Danaher Motion.

## NOTE

These products are being manufactured and sold by G & L Motion Control, Inc., a Danaher Motion company ("Danaher Motion").

Progress is an on-going commitment at Danaher Motion. We continually strive to offer the most advanced products in the industry; therefore, information in this document is subject to change without notice. The text and illustrations are not binding in detail. Danaher Motion shall not be liable for any technical or editorial omissions occurring in this document, nor for any consequential or incidental damages resulting from the use of this document.

Danaher Motion makes every attempt to ensure accuracy and reliability of the specifications in this publication. Specifications are subject to change without notice. Danaher Motion provides this information "AS IS" and disclaims all warranties, express or implied, including, but not limited to, implied warranties of merchantability and fitness for a particular purpose. It is the responsibility of the product user to determine the suitability of this product for a specific application.

DO NOT ATTEMPT to use any Danaher Motion product until the use of such product is completely understood. It is the responsibility of the user to make certain proper operation practices are understood. Danaher Motion products should be used only by qualified personnel and for the express purpose for which said products were designed.

Should information not covered in this document be required, contact the Customer Service Department, Danaher Motion, 672 South Military Road, P.O. Box 1960, Fond du Lac, WI 54936-1960. Danaher Motion can be reached by telephone at (920) 921-7100 or (800) 558-4808 in the United States or by e-mail at [glmotion.support@danahermotion.com](mailto:glmotion.support@danahermotion.com).

Catalog No. (Order No.) M.1301.5524

Printed Version Part No. M.3000.0525

Electronic Version Part No. M.3000.0524

Release 102607

©2007, Danaher Motion



# Table of Contents

<b>1 Introduction to the MMC Smart Drive.....</b>	<b>9</b>
1.1 Overview.....	9
1.2 Contents of This Manual.....	9
1.3 Software and Manuals.....	10
1.3.1 Required Software and Manuals.....	10
1.3.2 Suggested Manuals.....	10
1.4 Danaher Motion Support Contact.....	10
<b>2 Safety Precautions.....</b>	<b>11</b>
2.1 System Safety.....	11
2.1.1 User Responsibility.....	11
2.1.2 Safety Instructions.....	11
2.2 Safety Signs.....	12
2.3 Warning Labels.....	12
2.4 Safety First.....	13
2.5 Safety Inspection.....	13
2.5.1 Before Starting System.....	13
2.6 After Shutdown.....	13
2.7 Operating Safely.....	14
2.8 Electrical Service & Maintenance Safety.....	14
2.9 Safe Cleaning Practices.....	15
<b>3 Installing the Drive.....</b>	<b>17</b>
3.1 Storing the Drive Before Installation.....	17
3.2 Unpacking the Drive.....	17
3.3 Handling an MMC Smart Drive.....	17
3.4 Inspecting the Drive Before Installation.....	17
3.5 Complying with European Directives.....	18
3.6 Conforming with UL and cUL Standards.....	18
3.7 General Installation and Ventilation Requirements.....	18
3.8 Controlling Heat Within the System.....	19
3.9 Bonding.....	20
3.9.1 Bonding a Subpanel Using a Stud.....	20
3.9.2 Bonding a Ground Bus Using a Stud.....	20
3.9.3 Bonding a Ground Bus or Chassis Using a Bolt.....	20
3.9.4 Grounding Multiple Drive Cabinets.....	21
3.9.5 Bonding Multiple Subpanels.....	21
3.10 Drive Mounting Guidelines.....	21
3.11 Drive System Grounding Procedures.....	22
3.11.2 Grounding Multiple Drives in the Same Cabinet.....	25
3.12 System Wiring Guidelines.....	25
3.12.1 Recommended Signal Separation.....	26
3.12.2 Building Your Own Cables.....	28
3.12.3 Routing Cables.....	28
3.13 Wiring the Drive.....	28
3.13.1 Sizing the 24V Power Supply.....	28
3.13.2 System AC Power Wiring Guidelines.....	29
3.13.3 Connecting Interface Cables.....	30
3.13.4 Preparing Motor Connection Wires.....	31
<b>4 System Power Protection and Related Devices.....</b>	<b>35</b>

4.1 AC Input Power Requirements.....	35
4.2 Protection.....	36
4.2.1 Motor Overload Protection.....	36
4.2.2 Motor Thermal Protection.....	36
4.2.3 230V Smart Drive Protection Requirements.....	36
4.2.4 460V Smart Drive Protection Requirements.....	37
4.3 Line Reactors.....	40
4.3.1 Specifications and Dimensions for Required Line Reactors.....	41
4.4 Isolation Transformers.....	47
4.5 External Shunts.....	48
4.5.1 Choosing an External Shunt.....	48
4.5.2 External Shunt Resistor Kits.....	49
4.6 Line Filters.....	53
4.6.1 Line Filters and CE Compliance.....	53
4.6.2 Dimensions for 230V Line Filters.....	58
4.6.3 Dimensions for 460V Line Filters.....	59
<b>5 230V Single Phase MMC Smart Drive.....</b>	<b>61</b>
5.1 LEDs.....	61
5.2 Connectors and Switches on the 230V Drive.....	63
5.2.1 PiCPro Port (Digital Interfaced Drives).....	64
5.2.2 PiCPro Port (Analog Drives).....	65
5.2.3 Node Address Rotary Switch (Digital Interfaced MMC-SD Only).....	67
5.2.4 Digital Link Ports (Digital Interfaced MMC-SD Only).....	68
5.2.5 Feedback Connector (F1).....	70
5.2.6 Feedback Connector (F2) (Digital Interfaced MMC-SD Only).....	73
5.2.7 Drive I/O Connector (IO).....	75
5.2.8 24 VDC IN/Brake Terminal Strip.....	78
5.2.9 Motor Terminal Strip.....	79
5.3 Specifications - 230V MMC Smart Drive.....	80
5.3.1 General Data for all 230V Models.....	80
5.3.2 Physical and Electrical Data for 230V Drives.....	83
5.4 Dimensions for 230V MMC Smart Drive.....	84
<b>6 460V 3-Phase MMC Smart Drive.....</b>	<b>91</b>
6.1 LEDs.....	91
6.2 Connectors on the 460V Smart Drive.....	92
6.2.1 Size 1 460V Smart Drive Connectors.....	92
6.2.1.1 Shunt/DC Bus Terminals.....	93
6.2.1.2 AC Power Terminal Strip.....	94
6.2.1.3 Motor Terminals.....	94
6.2.1.4 24V Power Connector (J1).....	95
6.2.1.5 Motor Brake Terminals (X101).....	96
6.2.2 Size 2 460V Drive Smart Drive Connectors.....	97
6.2.2.1 AC Power Terminals.....	98
6.2.2.2 Motor Power Terminals.....	99
6.2.2.3 24V Power Connector (J1).....	100
6.2.3 Size 3 460V Drive Smart Drive Connectors.....	102
6.2.3.1 AC Power Terminals.....	103
6.2.3.2 Motor Power Terminals.....	104
6.2.3.3 24V Power Connector (J1).....	105
6.2.3.4 Motor Brake Terminals (X101).....	106
6.2.4 Size 4 460V Drive Smart Drive Connectors.....	107
6.2.4.1 AC Power Terminals.....	108

---

6.2.4.2 Motor Power Terminals .....	109
6.2.4.3 24V Power Connector (J1) .....	110
6.2.4.4 Motor Brake Terminals (X101).....	111
6.2.4.5 Fan Terminals (X36).....	112
6.3 Typical 460V Drive Connection Layout .....	113
6.4 Specifications - 460V MMC Smart Drive) .....	114
6.4.1 Common Data for Size 1, 2, 3, 4 (All Models).....	114
6.4.2 Physical/Electrical Data for 460V Size 1 Smart Drives .....	117
6.4.3 Physical/Electrical Data for 460V Size 2 Smart Drives .....	119
6.4.4 Physical/Electrical Data for 460V Size 3 Smart Drives .....	121
6.4.5 Physical/Electrical Data for 460V Size 4 Smart Drives .....	123
6.5 Dimensions for the 460V Smart Drives .....	125
<b>7 Cables and Connections to External Devices .....</b>	<b>133</b>
7.1 Flex Cable Installation Guidelines .....	133
7.1.1 Bending Radius.....	133
7.1.2 Cable Tension .....	133
7.2 Flex Cable Installation .....	134
7.3 I/O Cable Pin Assignments.....	136
7.4 LSM and MSM Motors Cable Pin Assignments .....	137
7.5 AKM/DDR Motors Cable Pin Assignments .....	140
7.6 FSM Motors Cable Pin Assignments .....	144
7.8 Connecting Shunt Modules .....	148
7.8.1 Connecting the 230V MMC Smart Drive to 300 W Shunt Module .....	148
<b>8 Maintenance and Troubleshooting.....</b>	<b>151</b>
8.1 Maintenance .....	151
8.2 Diagnostics.....	151
8.2.1 Power-On Diagnostics .....	151
8.2.1.1 Power LED .....	151
8.2.1.2 Diagnostic LEDs .....	151
8.2.2 Run-Time Diagnostics.....	152
8.3 Troubleshooting.....	152
8.3.1 General Troubleshooting.....	152
8.3.2 Troubleshooting Drive Diagnostic Fault Codes.....	152
8.3.3 Troubleshooting Drive Diagnostic Warning Codes .....	159
<b>9 Resolver Interface Option Module.....</b>	<b>161</b>
9.1 Theory of Operation.....	161
9.2 Installing the Resolver Module .....	161
<b>10 Drive Resident Digital MMC Control.....</b>	<b>165</b>
10.1 Introduction .....	165
10.1.1 Overview .....	165
10.1.2 Major Components.....	165
10.2 Installing the Drive Resident Digital MMC Control.....	167
10.2.1 Installing into a 230V MMC-SD Drive.....	167
10.2.2 Installing into a 460V MMC-SD Drive.....	167
10.3 System Wiring Guidelines .....	168
10.4 Starting an Operation .....	169
10.4.1 Connecting the Drive Resident Digital MMC Control to the Application.....	169
10.4.2 Basic Setup and Maintenance Procedures .....	169
10.4.3 Start-up Diagnostics.....	170
10.4.3.1 Power LED .....	170

10.4.3.2 Scan LED .....	170
10.4.3.3 Drive Resident Digital MMC Control Start-Up Diagnostic LEDs .....	171
10.4.4 MMC Run-Time Diagnostics.....	172
10.5 MMC Connections to External Devices for Machine Control .....	173
10.5.1 PiCPro Port (P1).....	173
10.5.2 Block I/O Port (C1) .....	173
10.5.3 User Port (C3) .....	174
10.5.4 Ethernet Port (C4) .....	174
10.5.5 General I/O Port (C5) .....	175
<b>11 Part Numbers .....</b>	<b>181</b>
11.1 230V Smart Drives .....	181
11.2 460V Smart Drives .....	182
11.3 Option Modules.....	184
11.3.1 Resolver Interface Option Module .....	184
11.3.2 Drive Resident Digital MMC Control.....	184
11.4 Direct Connect Cables .....	185
11.4.1 Drive Programming Cable .....	185
11.4.2 Standalone MMC to MMC Smart Drive I/O Cable .....	185
11.5 Digital Link and Networking Cables .....	185
11.6 Connector Kits .....	186
11.7 Breakout Boards and Cables .....	187
11.7.1 Drive Mounted Breakout Boards .....	187
11.7.2 Panel Mounted Breakout Boards.....	187
11.7.3 Breakout Board Kits.....	187
11.7.4 Breakout Board Cables .....	188
11.7.5 Flying Lead Cables.....	189
11.8 Motor Cables (AKM/DDR Motors) .....	190
11.8.1 Feedback Cables (AKM/DDR Motors).....	190
11.8.2 Motor Power Cables (AKM/DDR Motors) .....	192
11.9 Motor Cables (LSM/MSM Motors).....	193
11.9.1 Feedback Cables (LSM/MSM Motors) .....	193
11.9.2 Power Cables for Blower Fan (LSM/MSM Motors).....	194
11.9.3 Motor Power Cables (LSM/MSM Motors).....	194
11.10 Optional External Devices .....	196
11.10.1 AC Line Filters .....	196
11.10.2 AC Line Reactors .....	196
11.10.3 External Shunt Resistor Kits.....	197
11.11 Software.....	197
<b>12 Declarations of Conformity .....</b>	<b>199</b>
<b>Appendix A - 460V MMC Smart Drive DC Bus Sharing.....</b>	<b>205</b>
A.1 Introduction .....	205
A.2 DC Bus Sharing with AC Power to All Drives .....	205
A.3 DC Bus Sharing with AC Power to One Drive .....	207
<b>Index .....</b>	<b>211</b>
<b>Sales and Service .....</b>	<b>214</b>



# 1 Introduction to the MMC Smart Drive

## 1.1 Overview

This manual covers two distinct products:

- The Analog Interfaced MMC Smart Drive (MMC-SD) which receives motion commands via a  $\pm 10V$  analog input
- The Digital MMC Smart Drive (MMC-SD) which receives motion commands via a digital connection (Digital Link)

Unless otherwise noted, all of the information in this manual applies to both drives.

Features include:

- 230V, Single Phase drives available with power ratings of .5kW, 1kW, and 2 kW
- 460V, Three Phase drives available with power ratings of 1.3kW through 65kW
- Drive firmware in user upgradeable Flash memory
- Serial port for communications with PC-resident PiCPro
- Internal switch to control a mechanical brake
- Green Power LED and yellow Diagnostic LED
- Motor feedback types include incremental encoder, high resolution encoder, and resolver.
- Eight General Purpose 24VDC Inputs
- Four General Purpose 24VDC outputs
- $\pm 10V$  command input (Analog Interfaced MMC-SD only)
- Digital Link digital connections (Digital MMC-SD only)
- Optional MMC-SD Control (for Digital MMC-SD only)
- UL Listed and CE Marked.

## 1.2 Contents of This Manual

This manual includes the following major topics:

- Information to safely operate and maintain the equipment in a safe manner.
- User responsibilities for product acceptance and storage.
- Power and environmental information for general power, control cabinet, grounding, heat control and handling.
- Procedures for mounting, wiring, and connecting the MMC Smart Drive and standard Danaher Motion motors recommended for use with the MMC Smart Drive.
- Recommended drive system wiring guidelines for signal separation and differential devices. Methods to ensure ElectroMagnetic Compatibility.
- The location of connectors on the drive and descriptions of their functionality including I/O, encoder, serial interface and motor/brake connector locations and signal descriptions.
- Physical, electrical, environmental and functional specifications/dimensions.
- Description of the minimal maintenance necessary.

- A troubleshooting chart of potential problems and possible solutions.
- Part numbers and descriptions for the drive and related equipment.

## **1.3 Software and Manuals**

### **1.3.1 Required Software and Manuals**

PiCPro (one of the following)

- Professional Edition
- MMC Limited Edition
- Monitor Edition

### **1.3.2 Suggested Manuals**

- Function/Function Block Reference Guide
- Motion Application Specific Function Block Manual
- Ethernet Application Specific Function Block Manual
- General Purpose Application Specific Function Block Manual

## **1.4 Danaher Motion Support Contact**

Contact your local Danaher Motion representative for:

- Sales and order support
- Product technical training
- Warranty support
- Support service agreements

Danaher Motion Technical Support can be reached:

- In the United States, telephone (800) 558-4808
- Outside the United States, telephone (920) 921-7100
- E-mail address: [glmotion.support@danahermotion.com](mailto:glmotion.support@danahermotion.com)
- Web site: [www.glcontrols.com](http://www.glcontrols.com)

## 2 Safety Precautions

### **READ AND UNDERSTAND THIS SECTION IN ITS ENTIRETY BEFORE UNDERTAKING INSTALLATION OR ADJUSTMENT OF THE MMC SMART DRIVE AND ANY ASSOCIATED SYSTEMS OR EQUIPMENT**

The instructions contained in this section will help users to operate and maintain the equipment in a safe manner.

### **PLEASE REMEMBER THAT SAFETY IS EVERYONE'S RESPONSIBILITY**

#### 2.1 System Safety


The basic rules of safety set forth in this section are intended as a guide for the safe operation of equipment. This general safety information, along with explicit service, maintenance and operational materials, make up the complete instruction set. All personnel who operate, service or are involved with this equipment in any way should become totally familiar with this information prior to operating.

##### 2.1.1 User Responsibility

It is the responsibility of the user to ensure that the procedures set forth here are followed and, should any major deviation or change in use from the original specifications be required, appropriate procedures should be established for the continued safe operation of the system. It is strongly recommended that you contact your OEM to ensure that the system can be safely converted for its new use and continue to operate in a safe manner.

##### 2.1.2 Safety Instructions

- Do not operate your equipment with safety devices bypassed or covers removed.
- Only qualified personnel should operate the equipment.
- Never perform service or maintenance while automatic control sequences are in operation.
- To avoid shock or serious injury, only qualified personnel should perform maintenance on the system.

ATTENTION	
	Do not touch the main power supply fuses or any components internal to the power modules while the main power supply switch is ON. Note that when the main power switch is OFF, the incoming supply cable may be live.

- **GROUNDING (Protective Earth)**

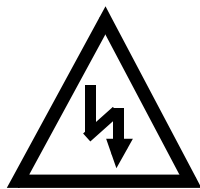
The equipment must be grounded (connected to the protective earth connection) according to OEM recommendations and to the latest local regulations for electrical safety. The grounding (protective earth) conductor must not be interrupted inside or outside the equipment enclosures. The wire used for equipment grounding (connection to protective earth) should be green with a yellow stripe.

## 2.2 Safety Signs

The purpose of a system of safety signs is to draw attention to objects and situations which could affect personal or plant safety. It should be noted that the use of safety signs does not replace the need for appropriate accident prevention measures. Always read and follow the instructions based upon the level of hazard or potential danger.

## 2.3 Warning Labels

### *Hazard warning*



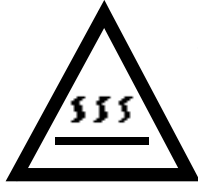
Danger Electric  
Shock Risk

When you see this safety sign on a system, it gives a warning of a hazard or possibility of a hazard existing. The type of warning is given by the pictorial representation on the sign plus text if used.

To ignore such a caution could lead to severe injury or death arising from an unsafe practice.

***Danger, Warning, or Caution warning***

Symbol plus DANGER, WARNING or CAUTION:  
These notices provide information intended to prevent potential personal injury and equipment damage.

***Hot Surface warning***

Symbol plus HOT SURFACE:  
These notices provide information intended to prevent potential personal injury.

**2.4 Safety First**

Danaher Motion equipment is designed and manufactured with consideration and care to generally accepted safety standards. However, the proper and safe performance of the equipment depends upon the use of sound and prudent operating, maintenance and servicing procedures by trained personnel under adequate supervision.

For your protection, and the protection of others, learn and always follow these safety rules. Observe warnings on machines and act accordingly. Form safe working habits by reading the rules and abiding by them. Keep these safety rules handy and review them from time to time to refresh your understanding of them.

**2.5 Safety Inspection****2.5.1 Before Starting System**

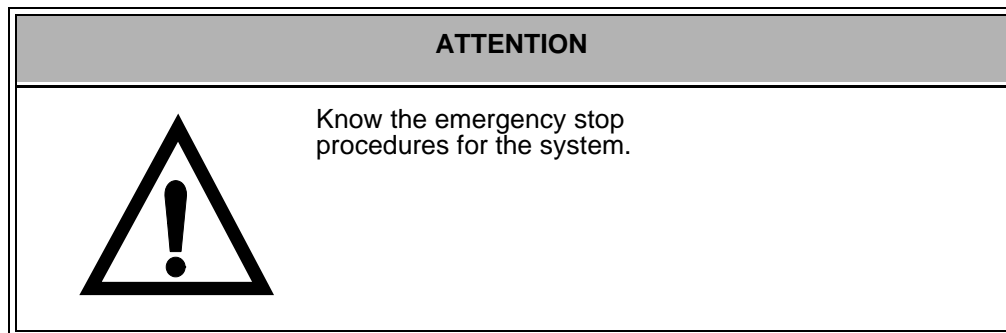
- Ensure that all guards and safety devices are installed and operative and all doors which carry warning labels are closed and locked.
- Ensure that all personnel are clear of those areas indicated as potentially hazardous.
- Remove (from the operating zone) any materials, tools or other objects that could cause injury to personnel or damage the system.
- Make sure that the control system is in an operational condition.
- Make certain that all indicating lights, horns, pressure gauges or other safety devices or indicators are in working order.

**2.6 After Shutdown**

Make certain all controlled equipment in the plant is safe and the associated electrical, pneumatic or hydraulic power is turned off. It is permissible for the control equipment contained in enclosures to remain energized provided this does not conflict with the safety instructions found in this section.

## 2.7 Operating Safely

- Do not operate the control system until you read and understand the operating instructions and become thoroughly familiar with the system and the controls.
- Never operate the control system while a safety device or guard is removed or disconnected
- Where access to the control system is permitted for manual operation, only those doors which provide that access should be unlocked. They should be locked immediately after the particular operation is completed.
- Never remove warnings that are displayed on the equipment. Torn or worn labels should be replaced.
- Do not start the control system until all personnel in the area have been warned.
- Never sit or stand on anything that might cause you to fall onto the control equipment or its peripheral equipment.
- Horseplay around the control system and its associated equipment is dangerous and should be prohibited.




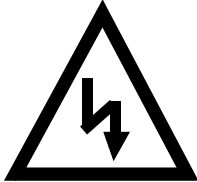
- Never operate the equipment outside specification limits.
- Keep alert and observe indicator lights, system messages and warnings that are displayed on the system.
- Do not operate faulty or damaged equipment. Make certain proper service and maintenance procedures have been performed.

## 2.8 Electrical Service & Maintenance Safety

- **ALL ELECTRICAL OR ELECTRONIC MAINTENANCE AND SERVICE SHOULD BE PERFORMED BY TRAINED AND AUTHORIZED PERSONNEL ONLY.**
- It should be assumed at all times that the POWER is ON and all conditions treated as live. This practice assures a cautious approach which may prevent accident or injury.
- To remove power:  
**LOCK THE SUPPLY CIRCUIT DISCONNECTING MEANS IN THE OPEN POSITION.**  
**APPLY LOCKOUT/TAGOUT DEVICES IN ACCORDANCE WITH A DOCUMENTED AND ESTABLISHED POLICY.**

- Make sure the circuit is safe by using the proper test equipment. Check test equipment regularly.

ATTENTION	
	Care should be taken if you are manually discharging the bus capacitors.

WARNING	
	Even after power to the drive is removed, it may take up to 10 minutes for bus capacitors to discharge to a level below 50 VDC. To be sure the capacitors are discharged, measure the voltage across the + and - terminals for the DC bus.

- There may be circumstances where troubleshooting on live equipment is required. Under such conditions, special precautions must be taken:
  - Make sure your tools and body are clear of the areas of equipment which may be live.
  - Extra safety measures should be taken in damp areas.
  - Be alert and avoid any outside distractions.
  - Make certain another qualified person is in attendance.
- Before applying power to any equipment, make certain that all personnel are clear of associated equipment.
- Control panel doors should be unlocked only when checking out electrical equipment or wiring. On completion, close and lock panel doors.
- All covers on junction panels should be fastened closed before leaving any job.
- Never operate any controls while others are performing maintenance on the system.
- Do not bypass a safety device.
- Always use the proper tool for the job.
- Replace the main supply fuses only when electrical power is OFF (locked out).

## 2.9 Safe Cleaning Practices

- Do not use toxic or flammable solvents to clean control system hardware.
- Turn off electrical power (lock out) before cleaning control system assemblies.
- Keep electrical panel covers closed and power off when cleaning an enclosure.

- Always clean up spills around the equipment immediately after they occur.
- Never attempt to clean a control system while it is operating.
- Never use water to clean control equipment unless you are certain that the equipment has been certified as sealed against water ingress. Water is a very good conductor of electricity and the single largest cause of death by electrocution.



## 3 Installing the Drive

### NOTE

The National Electrical Code and any other governing regional or local codes overrule the information in this manual. Danaher Motion does not assume responsibility for the user's compliance or non-compliance with any code, national, local or otherwise, for the proper installation of this drive and associated systems or equipment. Failure to abide by applicable codes creates the hazard of personal injury and/or equipment damage.

### 3.1 Storing the Drive Before Installation

The drive should remain in the shipping container prior to installation. If the equipment is not to be used for a period of time, store it as follows:

- Use a clean, dry location
- Maintain the storage temperature and humidity as shown in the specifications section of this manual.
- Store it where it cannot be exposed to a corrosive atmosphere
- Store it in a non-construction area

### 3.2 Unpacking the Drive

Remove all packing material, wedges, and braces from within and around the components. After unpacking, check the name plate Material Number against the purchase order of the item(s) against the packing list. The model number, serial number and manufacturing date code are located on the side of the unit.

### 3.3 Handling an MMC Smart Drive

The case protects the MMC Smart Drive's internal circuitry against mechanical damage in shipping and handling.

However, like any electronic device, the circuitry can be destroyed by:

- Conditions exceeding those detailed in the specifications tables shown in the Specifications sections in this manual.
- moisture condensing inside the module
- static discharge
- exposure to a magnetic field strong enough to induce a current in the circuitry
- vibration, and other hazards

### 3.4 Inspecting the Drive Before Installation

Inspect the unit for any physical damage that may have been sustained during shipment.

If you find damage, either concealed or visible, contact your buyer to make a claim with the shipper. If degraded performance is detected when testing the unit, contact your distributor or Danaher Motion. Do this as soon as possible after receipt of the unit.

### 3.5 **Complying with European Directives**

For industrial products installed within the European Union or EEC regions, certain directives and standards apply. See “Conformity” in the Specifications sections of Chapters 5 and 6 for applicable directives.

Servo amplifiers are considered to be subsystems when incorporated into electrical plants and machines for industrial use. The Danaher Motion servo amplifiers have been designed and tested as such. They bear the CE mark and are provided with a Declaration of Conformance. However, it is the overall machine or system design that must meet European Directives and standards. To help the manufacturer of the machine or plant meet these directives and standards, specific guidelines are provided in this documentation. These include such things as shielding, grounding, filters, treatment of connectors and cable layout.

### 3.6 **Conforming with UL and cUL Standards**

Danaher Motion drives meet safety and fire hazard requirements as outlined in “Conformity” in the Specifications sections of [Chapter 12, \*Declarations of Conformity\*](#).

### 3.7 **General Installation and Ventilation Requirements**

- The drive must be enclosed in a grounded NEMA12 enclosure offering protection to IP55 such that they are not accessible to an operator or unskilled person, in order to comply with UL<sup>®</sup> and CE requirements. A NEMA 4X enclosure exceeds these requirements providing protection to IP66.
- The environmental conditions must not exceed those detailed in the specifications tables shown in the Specifications sections in this manual.
- Install the panel on a properly bonded, flat, rigid, non-painted galvanized steel, vertical surface that won't be subjected to shock, vibration, moisture, oil mist, dust, or corrosive vapors.
- Maintain minimum clearances for proper airflow, easy module access, and proper cable bend radius.
- Plan the installation of your system so that you can perform all cutting, drilling, tapping, and welding with the drive removed from the enclosure. Because the drive is of the open type construction, be careful to keep any metal debris from falling into it. Metal debris or other foreign matter can become lodged in the circuitry, which can result in damage to components.

The MMC Smart Drive is suitable for operation in a pollution degree 2 environment (i.e., normally, only non-conductive pollution occurs). Install the drive away from all sources of strong electromagnetic noise. Such noise can interfere with MMC Smart Drive operation.

Protect the MMC Smart Drive system from all the following:

- conductive fluids and particles
- corrosive atmosphere
- explosive atmosphere

Diagrams included with this manual and recommendations may be modified if necessary so the wiring conforms to current NEC standards or government regulations.

<b>Table 3-1: Cabinet Clearance Dimensions</b>		
<b>Location</b>	<b>Minimum Clearance</b>	
	<b>230V Drive</b>	<b>460V Drive</b>
Above Drive Body	2.0 in. (50.8 mm)	4.0 in. (100 mm)
Below Drive Body	2.0 in. (50.8 mm)	4.0 in. (100 mm)
Each Side of Drive	.50 in. (12.7 mm)	None
In Front of Drive (for cabling)	3.0 in. (76.2 mm)	3.0 in. (76.2 mm)

<b>NOTE</b>
Use filtered or conditioned air in ventilated cabinets. The air should be free of oil, corrosives, or electrically conductive contaminants.

### 3.8 Controlling Heat Within the System

The MMC Smart Drive hardware case is designed to promote air circulation and dissipate heat. Normally no fans or air conditioners are needed. However, if the environment outside the control cabinet is hot or humid, you may need to use a fan, heat exchanger, dehumidifier or air conditioner to provide the correct operating environment.

Make sure that the temperature and humidity within the drive cabinet does not exceed that which is shown in the specifications sections of this manual.

Make sure that components installed in the cabinet with the MMC Smart Drive do not raise the temperature above system limits and that any hot spots do not exceed specifications. For example, when heat-generating components such as transformers, other drives or motor controls are installed, separate them from the drive by doing one of the following:

- Place them near the top of the control cabinet so their heat output rises away from the MMC Smart Drive.
- Put them in another control cabinet above or to one side of the cabinet with the MMC Smart Drive. This protects the MMC Smart Drive from both heat and electrical noise.

The MMC Smart Drive itself is a source of heat, though in most installations its heat dissipates without harmful effects. System heat is generated from power dissipated by:

- the drive
- field side input/output components
- other drives in the cabinet
- the logic power supply

- external shunt resistors
- line reactors

**CAUTION**

If the MMC Smart Drive is operated outside the recommended environmental limits, it may be damaged. This will void the warranty.

### 3.9 Bonding

Connecting metal chassis, assemblies, frames, shields and enclosures to reduce the effects of electromagnetic interference (EMI) is the process of bonding.

Most paints act as insulators. To achieve a good bond between system components, surfaces need to be paint-free or metal plated. Bonding metal surfaces creates a low-impedance exit path for high-frequency energy. Improper bonding blocks this direct exit path and allows high-frequency energy to travel elsewhere in the cabinet. Excessive high-frequency energy can negatively affect the operation of the drive.

#### 3.9.1 Bonding a Subpanel Using a Stud

1. Weld threaded mounting studs to the back of the enclosure.
2. Brush off any non-conductive materials (e.g. paint) from the studs.
3. Remove any non-conductive materials from the front of the subpanel.
4. Position the mounting holes on the subpanel over the mounting studs on the back of the enclosure and slide the subpanel onto the studs.
5. Attach the subpanel to the mounting stud by sliding a star washer over the stud and then turn and tighten a nut onto the stud.

#### 3.9.2 Bonding a Ground Bus Using a Stud

1. Weld threaded mounting studs to the back of the subpanel.
2. Brush off any non-conductive materials (e.g. paint) from the studs.
3. Slide a flat washer over the studs.
4. Remove any non-conductive materials from around the mounting hole on the chassis mounting bracket or ground bus.
5. Position the mounting hole of the chassis or ground bus over the studs on the back of the subpanel and slide the mounting bracket or ground bus onto the stud.
6. Attach the subpanel to the subpanel stud by sliding a star washer and then a flat washer over the stud. Turn and tighten a nut onto the stud.

#### 3.9.3 Bonding a Ground Bus or Chassis Using a Bolt

1. Brush off any non-conductive materials (e.g. paint) from the threaded bolt (s).
2. Slide a star washer over the threaded bolt (s).
3. Use a subpanel having tapped mounting holes. Remove any non-conductive materials from around the mounting holes on both sides of the subpanel.
4. Turn the threaded bolts into the subpanel mounting holes.

5. Slide a star washer onto the threaded end of the bolt.
6. Turn and tighten a nut onto the stud.
7. Slide a flat washer onto the threaded end of the bolt.
8. Position the mounting holes on the groundbus or mounting bracket over the threaded bolts and turn the bolts until they come through the grounding bus or mounting bracket.
9. Slide a star washer onto the threaded end of the bolt.
10. Slide a flat washer onto the threaded end of the bolt.
11. Turn and tighten a nut onto the bolt.

### 3.9.4 Grounding Multiple Drive Cabinets

1. Mount one bonded ground bus in each cabinet.
2. Designate the cabinet ground bus in one and only one of the cabinets as the common ground bus for all of the cabinets in the system.
3. Connect the ground wires from the ground bus in each individual cabinet ground bus to the designated common ground bus (mounted in only one of the cabinets).
4. Connect the common cabinet ground bus to an external ground system that is connected to a single point ground.

### 3.9.5 Bonding Multiple Subpanels

Danaher Motion recommends bonding both the top and bottom of subpanels sharing the same enclosure. Use a 25.4 mm (1.0 in.) x 6.35 mm (0.25) wire braid. Be sure the area around each wire braid fastener is clear of any non-conductive materials. Bond the cabinet ground bus to at least one of the subpanels.

#### NOTE

Subpanels that are not bonded together may not share a common low impedance path. This difference in impedance may affect networks and other devices that span multiple panels.

### 3.10 Drive Mounting Guidelines

- A control cabinet for the MMC Smart Drive should have a NEMA-12 rating or better. A cabinet with this rating protects its contents from dust and mechanical damage.
- The cabinet must be large enough to provide adequate air circulation for the MMC Smart Drive and other components. Always allow for adequate air flow through the MMC Smart Drive vents.
- The cabinet must have a rigid non-painted galvanized metal surface to mount the MMC Smart Drive on.

- The cabinet door should open fully for easy access.

**IMPORTANT**

Post warnings according to National, State, or local codes for the voltage present in the control cabinet. Diagrams included with this manual and recommendations may be modified if necessary so the wiring conforms to current NEC standards or government regulations.

**NOTE**

This drive contains parts and assemblies that are sensitive to ESD (Electrostatic Discharge). Follow static control precautions during installation, testing, service, or repair of this assembly. Parts and assemblies can be damaged if proper precautions are not taken.

1. Lay out the positions for the drive and accessories in the enclosure.
2. Attach the drive to the cabinet, first using the upper mounting slots of the drive and then the lower. The recommended mounting hardware is M5 metric(#10-32).
3. Tighten all mounting fasteners.

### 3.11 Drive System Grounding Procedures

The ground of the MMC Smart Drive power source must be connected directly to a **Single Point Ground (SPG)** tie block. The tie block should be made of brass or copper, bolted or brazed to the control cabinet. If the tie block is bolted rather than brazed, scrape away paint or grease at the point of contact. Put star washers between the tie block and the cabinet to ensure good electrical contact.

Metal enclosures of power supplies, drives, etc., should also have good electrical contact with the SPG.

Metal enclosures of power supplies, drives, etc., should also have good electrical contact with the SPG.

**CAUTION**

The Single Point Ground should be the only common point for all the ground lines. If not, ground loops may cause current flow among components of the system which can interfere with proper operation of the MMC Smart Drive.

Devices to be connected directly to the Single Point Ground include:

- Plant safety ground.
- Protective earth ground(s) from the MMC Smart Drive power terminals.
- The metal panel or cabinet on which the MMC Smart Drive is mounted.
- “Common” or “0 V” lines from power supplies that provide +24 power to devices and external power to the I/O modules and the devices to which they are connected.

- Protective grounds from the devices themselves, such as device drivers, machinery, and operator interface devices.
- Protective earth ground from line and load sides of any AC line filters.
- The ground of the power source of the computer workstation or laptop, if any, from which you monitor the system operation. An AC outlet in the control cabinet is recommended.
- Single point grounds from other control cabinets, if any, in the system.

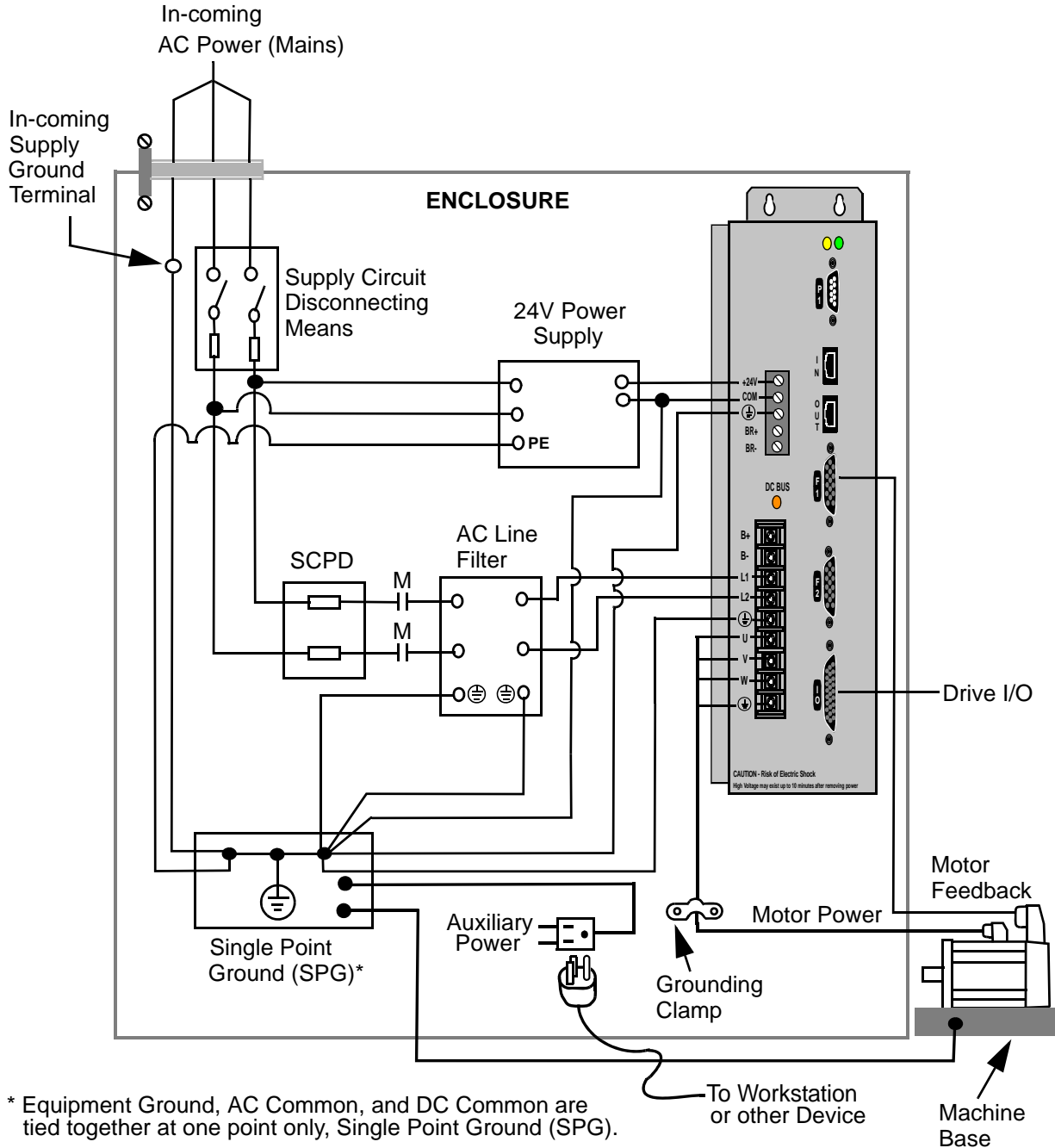
**IMPORTANT**

You must ensure that the "0V" or "Common" of all devices connected to the MMC Smart Drive are connected to Single Point Ground (SPG). Failure to do so may result in erratic operation or damage to the MMC Smart Drive and devices connected to it. Examples of devices connected to the MMC Smart Drive include the power source that supplies power to the MMC Smart Drive and devices connected to the MMC Smart Drive PiCPro Port. Note that some devices (for example, a Personal Computer) may have their "0V" and "Protective Earth Ground" connected together internally, in which case only one connection has to be made to SPG for that device. Also note that the AC/DC converter for some portable PCs have chassis connected from the wall plug to the PC. The ground for the AC outlet must be connected to the SPG.

Also, you must ensure that the MMC Smart Drive "Protective Earth Ground" connection is connected to SPG, and that the MMC Smart Drive is mounted to a metal panel or enclosure that is connected to SPG.

3.11.1 Grounding Requirements

Figure 3-1: Example of Grounding Required for CE Compliant Single Phase 230V Drive System



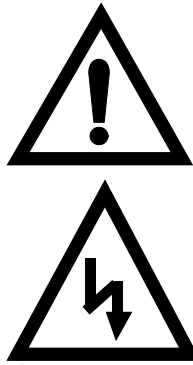
- Mount the filter as close to the Drive as possible. If the distance exceeds 600 mm (2.0 ft), use shielded cable between the Drive and the filter, strapping the shield to chassis at each end of the cable. This is particularly important for attenuation of higher frequency emissions (5-30 MHz).



- Shield or separate the wires connecting the AC power to the filter from other power cables (e.g., connections between the Drive and the filter, motor power cable, etc.). If the connections are not separated from each other, the EMI on the Drive side of the filter can couple over to the source side of the filter, thereby reducing or eliminating the filter's effectiveness. The coupling mechanism can radiate or allow stray capacitance between the wires.
- Bond the filter and the Drive to a grounded conductive surface (the enclosure) to establish a high frequency (HF) connection. To achieve the HF ground, the contact surface interface between the filter, Drive, and the enclosure should be free from paint or any other type of insulator.
- Size the filter following manufacturer recommendations.
- Provide a large enough ground bar to connect all wires with no more than two wires per connection.
- Clamp motor power cable shield for EMC termination.

**IMPORTANT**

Filter AC power to the drives to be compliant to CE emission requirements.

**WARNING**

High voltage exists in AC line filters. The filter must be grounded properly before applying power. Filter capacitors retain high voltages after power removal. Before handling the equipment, voltages should be measured to determine safe levels. Failure to observe this precaution could result in personal injury.

### 3.11.2 Grounding Multiple Drives in the Same Cabinet

1. Mount a common bonded ground bus in the cabinet.
2. Connect the ground wires for all drives to the common bonded cabinet ground bus.
3. Connect the common bonded cabinet ground bus to an external ground system that is connected to a single point ground.

### 3.12 System Wiring Guidelines

The MMC Smart Drive relies on electrical signals to report what is going on in the application and to send commands to it. In addition, signals are constantly being

exchanged within the system. The MMC Smart Drive is designed for use in industrial environments, but some guidelines should be followed.

This section contains common system wiring configurations, size, and practices that can be used in a majority of applications. National Electrical Code, local electrical codes, special operating temperatures, duty cycles, or system configurations take precedence over the values and methods provided.


Wherever possible, install wiring and related components in the following order:

1. main power line disconnecting means
2. transformer (optional)
3. fuses (SCPD)
4. motor control
5. line reactor (as required)
6. line filter (optional)
7. device protection fuses (as required)
8. drive
9. shunt resistors (optional)


### 3.12.1 Recommended Signal Separation

Danaher Motion recommends separation of low level signals (encoder, analog, communications, fast DC inputs) from high voltage or high current lines. Maintain at least two inches of separation.

Inside a control cabinet, connect the shields of shielded cables at the MMC Smart Drive. It is recommended that factory cables (from Danaher Motion) are used between MMC drives, controls, and motors to ensure CE compliance.

<b>WARNING</b>	
	Use care when wiring I/O devices to the MMC Smart Drive and when plugging in cables. Wiring the wrong device to the connector or plugging a connector into the wrong location could cause intermittent or incorrect machine operation or damage to equipment.

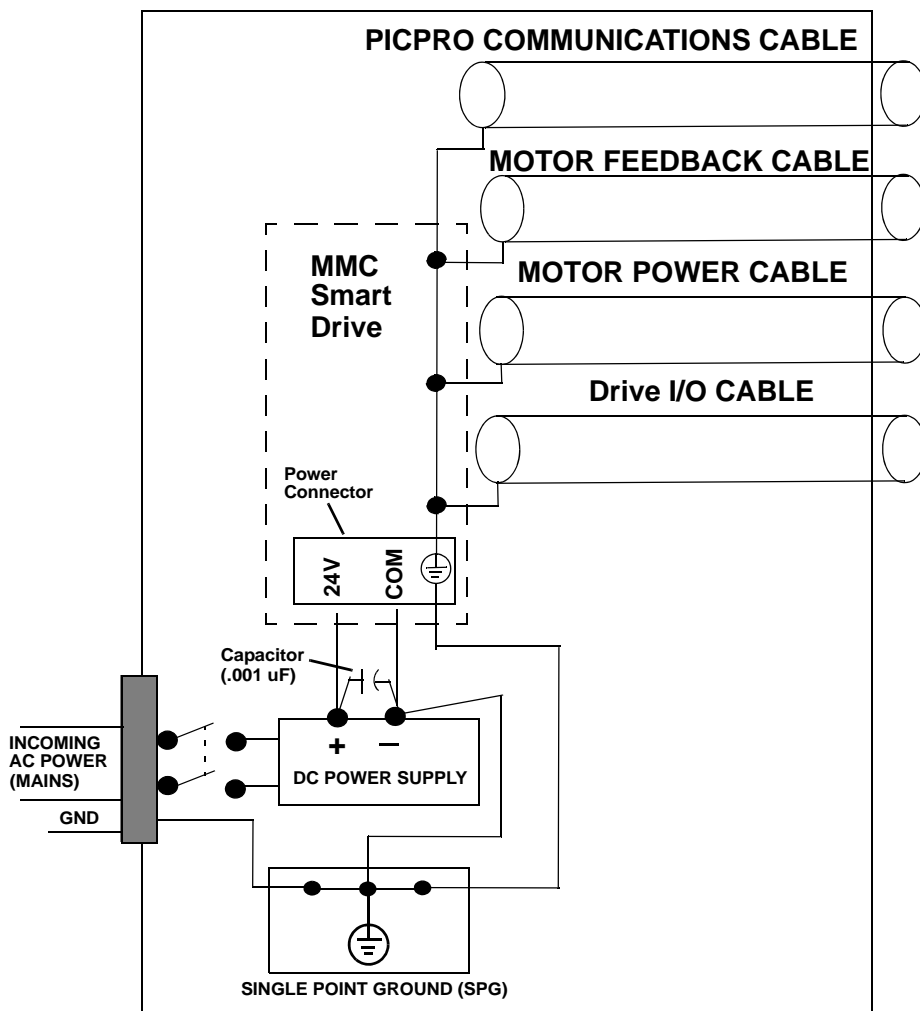
**WARNING: FEEDBACK DEVICE DAMAGE**



**Feedback Cable Installation and Removal**

All power to the Smart Drive (24 Vdc and main AC power) must be removed before connecting/disconnecting feedback cable connectors at the Smart Drive (F1 and F2 connector) or at the motor feedback device. Also, all connections must be secure when power is applied. Failure to follow these precautions may result in damage to the feedback device or Smart Drive.

**Figure 3-2: Recommended Signal Separation**



To prevent excessive conducted emissions from a DC power source (typically 24V) used for digital I/O, a .001 micro farad capacitor should be used. Connect the capacitor from the +24V DC to COMMON at the distribution terminals.

### 3.12.2 Building Your Own Cables

- Connect the cable shield to the connector shells on both ends of the cable for a complete 360 degree connection.
- Use a twisted pair cable whenever possible, twisting differential signals with each other, and single-ended signals with the appropriate ground return.

NOTE
Danaher Motion cables are designed to minimize EMI and are recommended over hand-built cables.

### 3.12.3 Routing Cables

Guidelines for routing cables in a cabinet include the following:

- Always route power and control cables separately.
- Do not run high and low voltage wires/cable in the same wireway.
- Cross high and low voltage conductors at 90 degree angles.
- On parallel cable runs, maximize the distance between high and low voltage cables.
- Maintain the least amount of unshielded cable leads.

## 3.13 Wiring the Drive

These procedures assume you have bonded and mounted your MMC Smart Drive to the subpanel and that there is no power applied to the system.

### 3.13.1 Sizing the 24V Power Supply

When you size your power supply, you must ensure that the supply is large enough to handle the total load. Refer to the specification tables for the +24VDC input power requirements.

In most cases, one power supply can be used for an entire control system. However, depending upon the drives and external I/O used in the application, the power distribution may be split into two or more power supplies.

Use of switches in series with the 24VDC power input is not recommended. The drive contains energy storage capacitors at the inputs. While no harm is done to the drive, this much capacitance across the 24VDC source may cause voltage dips when the switch in series with the 24VDC power is closed.

**CAUTION**

A possible ignition hazard within the MMC Smart Drive exists if excessive current is drawn from the 24 VDC powering the MMC Smart Drive. To prevent this possibility (due to improper wiring or 24 VDC supply failure), a fuse should be used in series with the 24 VDC to the MMC Smart Drive. Specifically, a 4 A max. "UL248 Series" fuse should be used. In addition, the 24 VDC shall be supplied by an isolating source such that the maximum open circuit voltage available to the MMC Smart Drive is not more than 30 VDC.

The +24V power to the MMC Smart Drive is connected through a Phoenix 5-pin connector with a plug-in terminal block. The ground from the power source and the ground from the MMC Smart Drive must be connected to the Single-Point Ground (SPG). Devices connected to the Drive I/O Port may have their own power sources for input or output control signals provided that each one is:

- at the correct voltage and current levels for the module and the device.
- connected to the same Single-Point Ground that the MMC Smart Drive uses.

It is recommended that the same main disconnect switch be used for the MMC Smart Drive and for all devices in the application.

**IMPORTANT**

No matter how the system is installed, before you connect the MMC Smart Drive to the application, make sure that power is off to the system and to the devices that are wired to the MMC Smart Drive.

### 3.13.2 System AC Power Wiring Guidelines

**NOTE**

In addition to the guidelines listed below, follow all national and local electrical codes and regulations.

- Install a supply circuit disconnecting means.
- Install a Short Circuit Protective Device (SCPD).
- Due to high inrush current at power-up, use dual element time delay fuses for the SCPD.
- Install additional device protection fusing (460V models). Only high speed type fuses provide proper protection.
- Refer to the Specifications sections in Chapter 4 of this manual for device and conductor requirements.
- Clamp the motor power cable shield to the drive using the Danaher Motion supplied bracket. Maximum tightening torque for bracket screws is 10 lb-in.

- Use shielded cables and AC line filters (for CE Compliance). Make sure that wiring from the drive to the line filter is as short as possible. Locate common grounding bus bars as close as possible to the drive. The braid shield of the cable should be clamped at the drive or mounting panel.
- Power connections for each drive in a system should be separately connected directly to the AC power supply. Do not daisy chain drive power connections.
- Make sure the phase to neutral ground voltage does not exceed the input ratings of the drive when using an autotransformer.

### 3.13.3 Connecting Interface Cables

#### IMPORTANT

This drive contains ESD (Electrostatic Discharge) sensitive parts and assemblies. Follow static control precautions when installing, testing, servicing, or repairing components in a drive system.


- Plug PiCPro cable into the PiCPro port (9-pin D-shell for the Analog Interfaced MMC-SD, and 6-pin mini-din for the Digital Interfaced MMC-SD).
- Plug the one 15-pin D-shell, Feedback cable into the FBK1 connector.
- Plug the 26-pin D-shell, Drive I/O cable into the I/O connector.
- Tighten the attachment screws for all cables to the drive connectors.

#### WARNING



To avoid personal injury and/or equipment damage:

- Ensure installation complies with specifications regarding wire types, conductor sizes, branch circuit protection, and disconnect devices. The National Electrical Code (NEC) and local codes outline provisions for safely installing electrical equipment.
- Ensure motor power connectors are used for connection purposes only. Do not use them to turn the unit on and off.
- To avoid personal injury and/or equipment damage, ensure shielded power cables are grounded to prevent potentially high voltages on the shield.

WARNING: FEEDBACK DEVICE DAMAGE	
	<p><b>Feedback Cable Installation and Removal</b></p> <p>All power to the Smart Drive (24 Vdc and main AC power) must be removed before connecting/disconnecting feedback cable connectors at the Smart Drive (F1 and F2 connector) or at the motor feedback device. Also, all connections must be secure when power is applied. Failure to follow these precautions may result in damage to the feedback device or Smart Drive.</p>

### 3.13.4 Preparing Motor Connection Wires

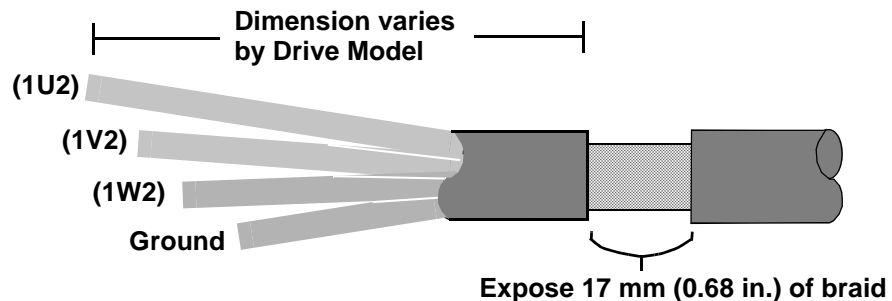
NOTE
<p>It is recommended that Danaher Motion cables be used. Danaher Motion cables are designed to minimize EMI and are recommended over hand-built cables.</p>

1. Strip back cable jacket approximately 152 mm (6.0 in.) from the end of the cable.
2. Strip approximately 12 mm (0.50 in.) of insulation from the end of each conductor. Do not tin ends after stripping.

IMPORTANT
<p>Do not nick, cut or damage wire strands while removing wire insulation.</p>

3. Strip the cable jacket away from the cable until the shield braid is visible. Expose 17 mm (0.68 in.) of cable shield braid.

**Figure 3-3: : Motor Cable**



4. Attach the individual wires from the motor cable to their assigned terminal. Refer to Chapters 5 and 6 for front panel connectors and terminal assignments.

5. Tighten each terminal screw.
6. Gently pull on each wire to make sure it does not come out of its terminal. Reinsert and tighten any loose wires.
7. Attach the plastic cover to terminal block

Factory supplied motor power cables for LSM, MSM, FSM, AKM, DDR, CDDR, and YSM Series motors are shielded, and the power cable is designed to be terminated at the drive during installation. A small portion of the cable jacket is removed which exposes the shield braid. The exposed shield braid must be clamped to the drive chassis using the provided clamp and clamp screws

**Figure 3-4: Terminating Motor Power Cable for 230V Drive**

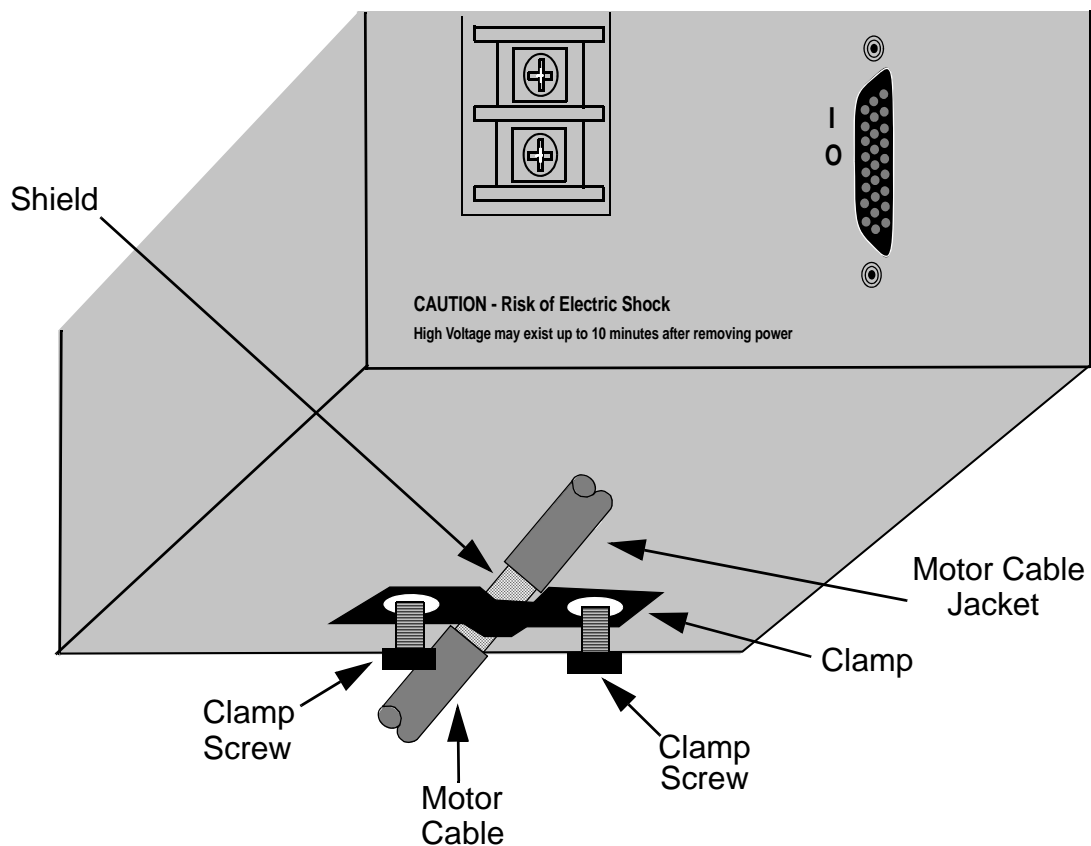
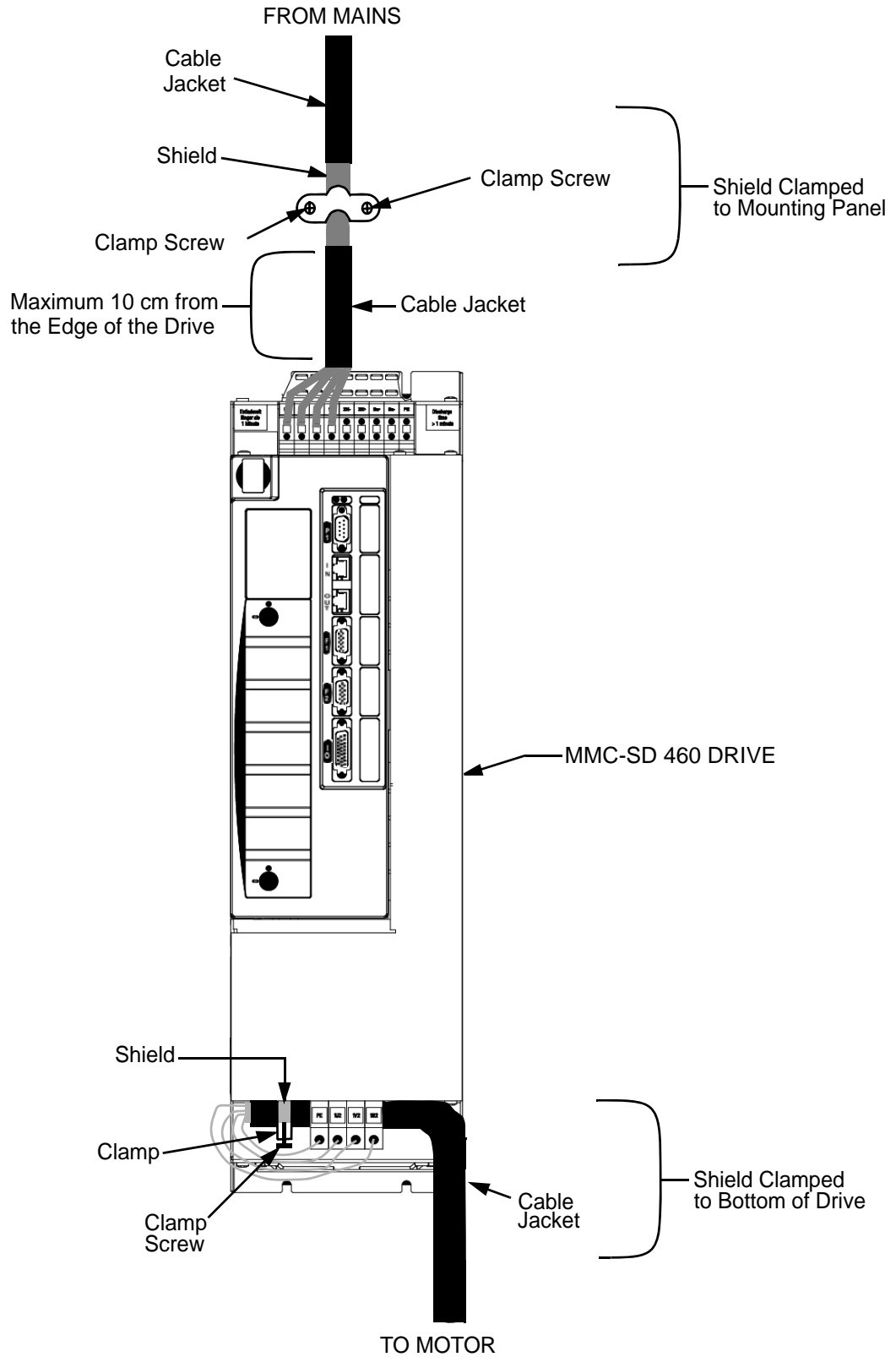




Figure 3-5: Terminating Incoming AC Power (Mains) Cable for 460V Drive





## 4 System Power Protection and Related Devices

### 4.1 AC Input Power Requirements

The MMC Smart Drive is powered from an external AC power source. The power required for each drive type is listed in [Table 4-1](#).

Table 4-1: AC Input Power Requirements				
Drive Model <sup>a</sup>	Requirements			
	Nominal Input Current (Amps <sub>RMS</sub> )		Transformer (kVA) <sup>b</sup>	
230 Volt Drives <sup>a</sup>	Input Voltage = 120VAC	Input Voltage = 230VAC	Input Voltage = 120VAC	Input Voltage = 230VAC
MMC-SD-0.5-230	5	5	.5	1
MMC-SD-1.0-230	9	9	1	2
MMC-SD-2.0-230	18	18	2	4
460 Volt Drives <sup>a</sup>	Input Voltage = 230VAC	Input Voltage = 460VAC	Input Voltage = 230VAC	Input Voltage = 460VAC
MMC-SD-1.3-460	2.8	2.44	1.2	3.0
MMC-SD-2.4-460	4.8	4.18	2.0	5.0
MMC-SD-4.0-460	8.1	7.0	3.4	8.5
MMC-SD-6.0-460	12.4	10.8	5.2	12.8
MMC-SD-8.0-460	17.0	14.8	7.0	17.6
MMC-SD-12.0-460	19.2	16.7	8.0	19.5
MMC-SD-16.0-460	24.2	21.1	10.0	25.0
MMC-SD-24.0-460	38.0	33.1	16.0	39.5
MMC-SD-30.0-460	53.0	46.0	22.0	55.0
MMC-SD-42.0-460	70.0	70.0	29.0	73.0
MMC-SD-51.0-460	84.0	73.0	35.0	87.0
MMC-SD-65.0-460	105	91.0	44.0	110

a. Drive Model pertains to Analog (no dash suffix) and digital (-D & -DN)

b. See [section 4.4 on page 47](#) for calculating application transformer requirement

## 4.2 Protection

### 4.2.1 Motor Overload Protection

The MMC Smart Drive utilizes solid state motor overload protection in accordance with UL508C that operates:

- within 8 minutes at 200% overload
- within 20 seconds at 600% overload

### 4.2.2 Motor Thermal Protection

The motor may be supplied with one of the following thermal protectors:

- A thermostat (normally closed, contacts rated at 10ma or greater). The thermostat's contact will open when the motor's maximum operating temperature is exceeded. Connect the thermostat between 0V and pin 11 of the drive's Feedback Connector (F2).
- A thermistor (Phillips KTY84-130 PTC or equivalent recommended). The motor manufacturer will provide the motor's maximum operating temperature. This temperature may be entered into the Motor Temperature Parameters in PiCPro. Connect the thermistor output to pin 11 of the drive's Feedback Connector (F2).

### 4.2.3 230V Smart Drive Protection Requirements

Two types of Protection must be provided in case the Smart Drive malfunctions:

- Short Circuit Protection - this protection helps minimize damage to the Smart Drive in the case of a Short Circuit condition. Short Circuit Protection is required to meet UL508C requirements.
- Branch Circuit Over Current Protection - this protection helps minimize damage to the Smart Drive and helps protect the wiring between the Smart Drive and the Over Current Protection Device in the case of a sustained Over Current condition. Over Current Protection must be provided in accordance with NFPA 79 7.2.3 and 7.2.10. Supplemental UL1007 protectors **shall not** be used to provide Branch Circuit Protection.

When using the 230V Smart Drive, the fuse that provides Short Circuit Protection also provides Over Current Circuit Protection, therefore a separate Short Circuit Protection fuse is not required.

Two types of fuses are defined for use with the 230V Smart Drive:

**Non-restricted** - If the Branch Circuit supplying power to the drive is capable of delivering no more than 5,000 RMS symmetrical short circuit amperes (240V maximum), the fuse type provided for Protection has no "Clearance  $I^2t$ " restrictions, and must meet the following requirements:

- have a current rating no greater than the "Maximum Fuse Size" in [Table 4-2](#)
- have an interrupt capability no less than the short circuit rating (Prospective Short-circuit Symmetrical Amperes) of the Branch Circuit supplying the drive.

**Restricted** - If the Branch Circuit supplying power to the drive is capable of delivering between 5,000 and 100,000 RMS symmetrical short circuit amperes (240V maximum), the fuse type provided for Protection has "Clearance  $I^2t$ " restrictions, and must meet the following requirements:

- meet both of the requirements for a non-restricted fuse (above)
- be a Class RK1, J, or CC dual element current limiting fuse

230V Drive Model <sup>a</sup>	Maximum Fuse Size <sup>b</sup>	
	V <sub>IN</sub> = 120VAC	V <sub>IN</sub> = 230VAC
MMC-SD-0.5-230	12A	12A
MMC-SD-1.0-230	15A	15A
MMC-SD-2.0-230	30A	30A

a. Drive model pertains to Analog (no dash suffix) and Digital (-D & -DN) versions

b. This is the maximum fuse size that can be used for Device Protection

#### 4.2.4 460V Smart Drive Protection Requirements

Two types of Protection must be provided in case the Smart Drive malfunctions:

- Short Circuit Protection - this protection helps minimize damage to the Smart Drive in the case of a Short Circuit condition. Short Circuit Protection is required to meet UL508C requirements.
- Branch Circuit Over Current Protection - this protection helps minimize damage to the Smart Drive and helps protect the wiring between the Smart Drive and the Over Current Protection Device in the case of a sustained Over Current condition. Over Current Protection must be provided in accordance with NFPA 79 7.2.3 and 7.2.10. Supplemental UL1007 protectors **shall not** be used to provide Branch Circuit Protection.

Two types of fuses are defined for use with the 460V Smart Drive:

**Non-restricted** - If the Branch Circuit supplying power to the drive is capable of delivering no more than 5,000 RMS symmetrical short circuit amperes (480V maximum), the fuse type provided for Protection has no “Clearance I<sup>2</sup>t” restrictions, and must meet the following requirements:

- have a current rating no greater than the “Maximum Fuse Size” in [Table 4-3](#)
- have an interrupt capability no less than the short circuit rating (Prospective Short-circuit Symmetrical Amperes) of the Branch Circuit supplying the drive.

**Restricted** - If the Branch Circuit supplying power to the drive is capable of delivering between 5,000 and 100,000 RMS symmetrical short circuit amperes (480V maximum), the fuse type provided for Protection has “Clearance I<sup>2</sup>t” restrictions, and must meet the following requirements:

- meet both of the requirements for a non-restricted fuse (above)
- have a “Clearance I<sup>2</sup>t” rating no greater than the “Clearance I<sup>2</sup>t” rating in [Table 4-3](#)

The requirements for both restricted and non restricted fuses may be met by using one of two methods:

- Use a single fuse that meets all requirements. The easiest way to accomplish this is to use a “Combination Fuse” from [Table 4-3](#). These fuses meet all of the requirements for both Short Circuit Protection and Over Current Protection, and may be used on Branch Circuits that supply up to 100,000 RMS symmetrical short circuit amperes (480V maximum).
- Use two fuses connected in series, that, in combination, meet all of the requirements:
  - Use an Over Current Protection fuse that has a current rating not greater than the “Maximum Fuse Size” shown in [Table 4-3](#), and an interrupt capability not less than the short circuit rating (Prospective Short-circuit Symmetrical Amperes) of the Branch Circuit supplying the drive.
  - Use a Short circuit Protection fuse (typically a semiconductor fuse) that has a “Clearance  $I^2t$ ” rating not greater than that shown in [Table 4-3](#), and a current rating greater than the Over Current Protection fuse (to avoid nuisance tripping).

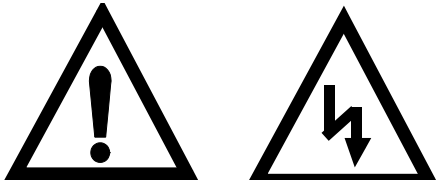
Table 4-3: 460V Smart Drive Protection Devices					
460V Drive Model <sup>a</sup>	I <sup>2</sup> t Rating <sup>b</sup>	Maximum Fuse Size <sup>c</sup>		Ferraz (Bussmann) Combination Fuse <sup>d</sup>	
		V <sub>IN</sub> = 230VAC	V <sub>IN</sub> = 460VAC	V <sub>IN</sub> = 230VAC	V <sub>IN</sub> = 460VAC
460 Volt Drives <sup>a</sup>		V <sub>IN</sub> = 230VAC	V <sub>IN</sub> = 460VAC	V <sub>IN</sub> = 230VAC	V <sub>IN</sub> = 460VAC
MMC-SD-1.3-460	< 228A <sup>2</sup> s	11A	9A	HSJ6(DFJ6)	HSJ6(DFJ6)
MMC-SD-2.4-460	≤ 228A <sup>2</sup> s	19A	16A	HSJ15(DFJ15)	HSJ15(DFJ15)
MMC-SD-4.0-460	≤ 260A <sup>2</sup> s	32A	27A	HSJ15(DFJ15)	HSJ15(DFJ15)
MMC-SD-6.0-460	≤ 340A <sup>2</sup> s	49A	41A	HSJ20(DFJ20)	HSJ20(DFJ20)
MMC-SD-8.0-460	≤ 616A <sup>2</sup> s	68A	56A	HSJ30(DFJ30)	HSJ25(DFJ25)
MMC-SD-12.0-460	≤ 1, 555A <sup>2</sup> s	76A	64A	HSJ35(DFJ35)	HSJ30(DFJ30)
MMC-SD-16.0-460	≤ 1, 555A <sup>2</sup> s	96A	80A	HSJ40(DFJ40)	HSJ35(DFJ35)
MMC-SD-24.0-460	≤ 1, 555A <sup>2</sup> s	152A	126A	HSJ60(DFJ60)	HSJ45(DFJ45)
MMC-SD-30.0-460	≤ 15,000A <sup>2</sup> s	212A	176A	N/A <sup>e</sup> (DFJ80)	N/A <sup>e</sup> (DFJ60)
MMC-SD-42.0-460	≤ 15,000A <sup>2</sup> s	280A	233A	HSJ125(DFJ125)	HSJ100(DFJ100)
MMC-SD-51.0-460	≤ 83,700A <sup>2</sup> s	336A	280A	HSJ150(DFJ150)	HSJ110(DFJ110)
MMC-SD-65.0-460	≤ 83,700A <sup>2</sup> s	420A	350A	HSJ175(DFJ175)	HSJ125(DFJ125)

- a. Drive model pertains to analog (no dash suffix) and Digital (-D)
- b. This is the maximum “Clearance I<sup>2</sup>t Rating” of a fuse used for Device Protection. Use a fuse that falls in the operating point below the stated release integral (I<sup>2</sup>t). All of the listed “Combination Fuses” meet this requirement.
- c. This is the maximum fuse size that can be used for Device and Branch Circuit Protection
- d. Listed devices are UL Recognized. These fuses have an Interrupt current of 100,000A
- e. Combination fuse not available from Ferraz for this drive

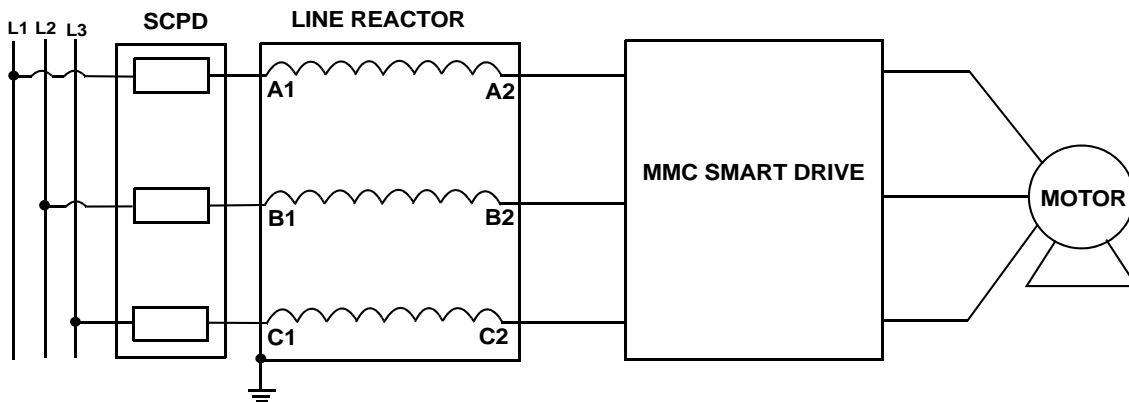
### 4.3 Line Reactors

AC Line Reactors are required when using some models of the MMC Smart Drive. They protect the drive from impermissible rates of current change and reduce harmonic current distortions. When required, they are mounted between the drive and the mains input power source.

NOTE
<p>Multiple drives or inverters on a common power line require one reactor per drive. Individual reactors provide filtering between each drive (and thereby reduce crosstalk) and also provide optimum surge protection for each unit. A single reactor serving several drives does not provide adequate protection, filtering or harmonic reduction when the system is partially loaded. Refer to <a href="#">Figure 4-1</a> for an example of one line reactor connected to one drive.</p>

WARNING

<p>Danger Electric Shock Risk</p>
<p>The frame of line/load reactors must be grounded at one of the reactor mounting holes typically by using a star washer under the heads of the mounting bolts. INJURY OR DEATH MAY RESULT IF THESE SAFETY PRECAUTIONS ARE NOT OBSERVED.</p>

**Figure 4-1: Line Reactor Connection (Simplified)**



Line reactors are not necessary for the 230V MMC Smart Drives or the 460V size 1 and 2 MMC Smart Drives. Line reactors are required for the 460V size 3 and size 4 MMC Smart Drives.



4.3.1 Specifications and Dimensions for Required Line Reactors

Table 4-4: MMC-SD-12-460 Line Reactor Specifications				
Fundamental Amperage	Power Loss	Inductance	Weight	Part Number
25A	52W	1.2 mH	14 lbs.	M.1302.7373

0.38 x 0.75 (4 SLOTS)

3.00

3.43 MAX

2.35

LABEL

WIRE RANGE: 22-5 AWG

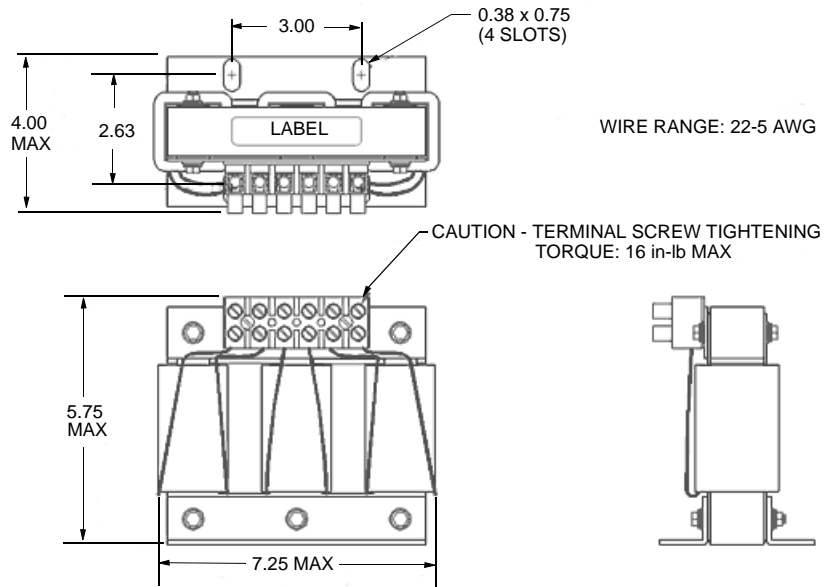
CAUTION - TERMINAL SCREW TIGHTENING TORQUE: 16 in-lb MAX

6.00 MAX

7.25 MAX

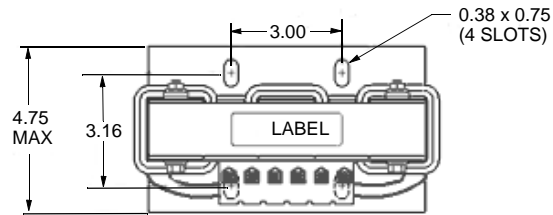
**Table 4-5: MMC-SD-16-460 Line Reactor Specifications**

Fundamental Amperage	Power Loss	Inductance	Weight	Part Number
35A	54W	0.8 mH	16 lbs.	M.1302.7374

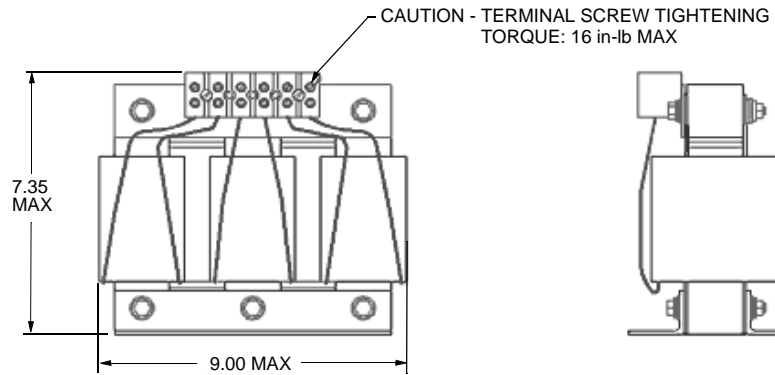


**Table 4-6: MMC-SD-24-460 Line Reactor Specifications**

Fundamental Amperage	Power Loss	Inductance	Weight	Part Number
45A	62W	0.7 mH	28 lbs.	M.1302.7375

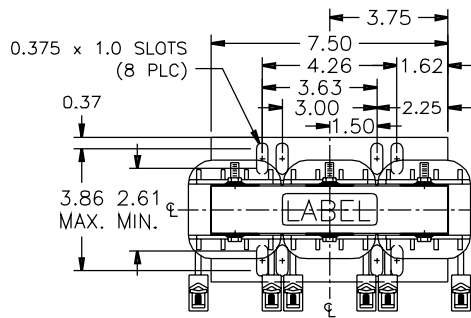


WIRE RANGE: 18-4 AWG



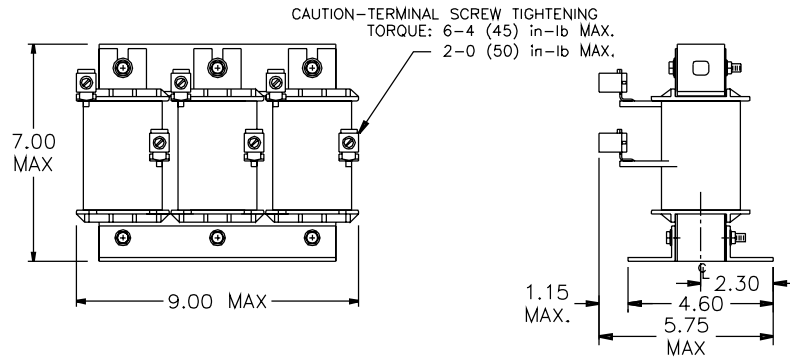
**Table 4-7: MMC-SD-30-460 Line Reactor Specifications**

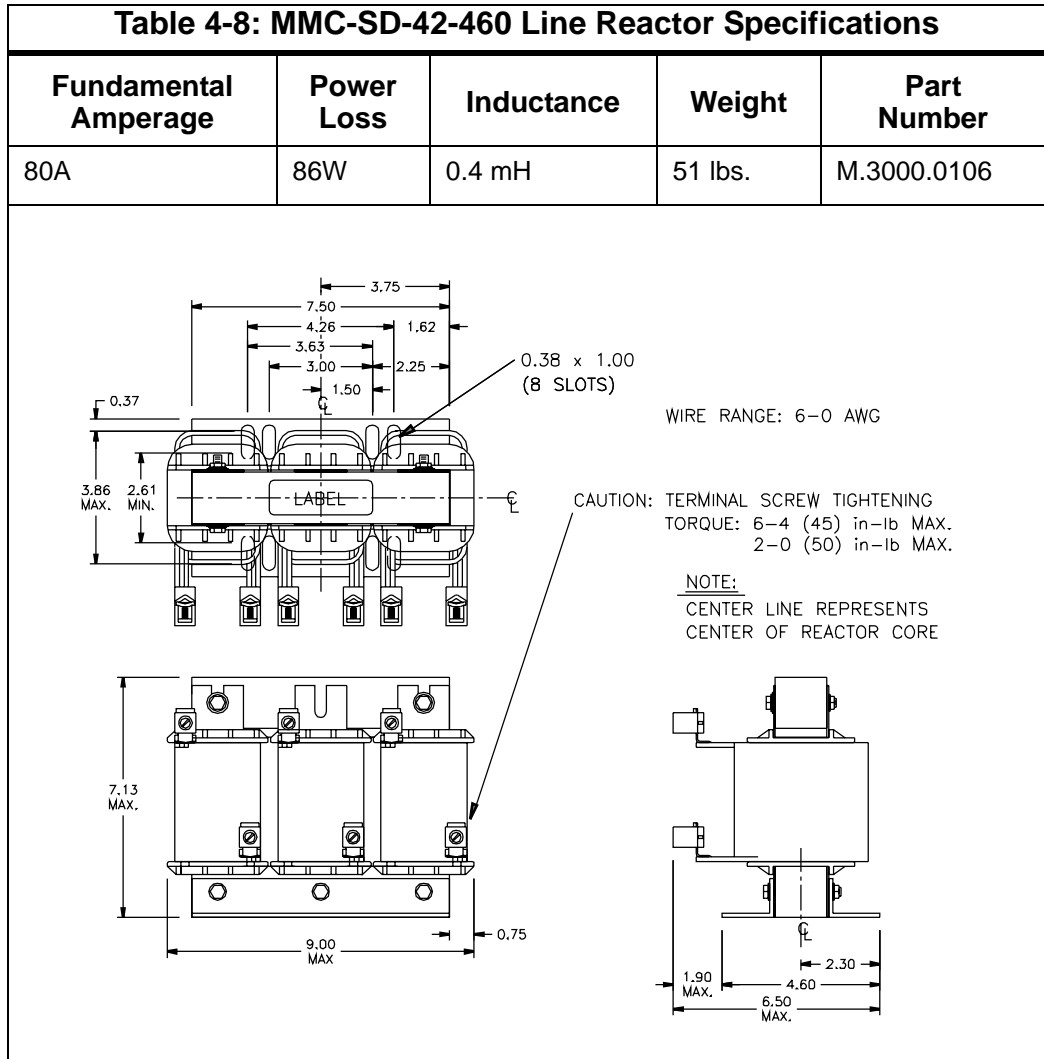
Fundamental Amperage	Power Loss	Inductance	Weight	Part Number
55A	67W	0.5 mH	27 lbs.	M.3000.0105



WIRE RANGE: 6-0 AWG

NOTE:  
CENTER LINE REPRESENTS  
CENTER OF REACTOR CORE





**Table 4-9: MMC-SD-51-460 Line Reactor Specifications**

Fundamental Amperage	Power Loss	Inductance	Weight	Part Number
100A	84W	0.3 mH	51 lbs.	M.3000.0107

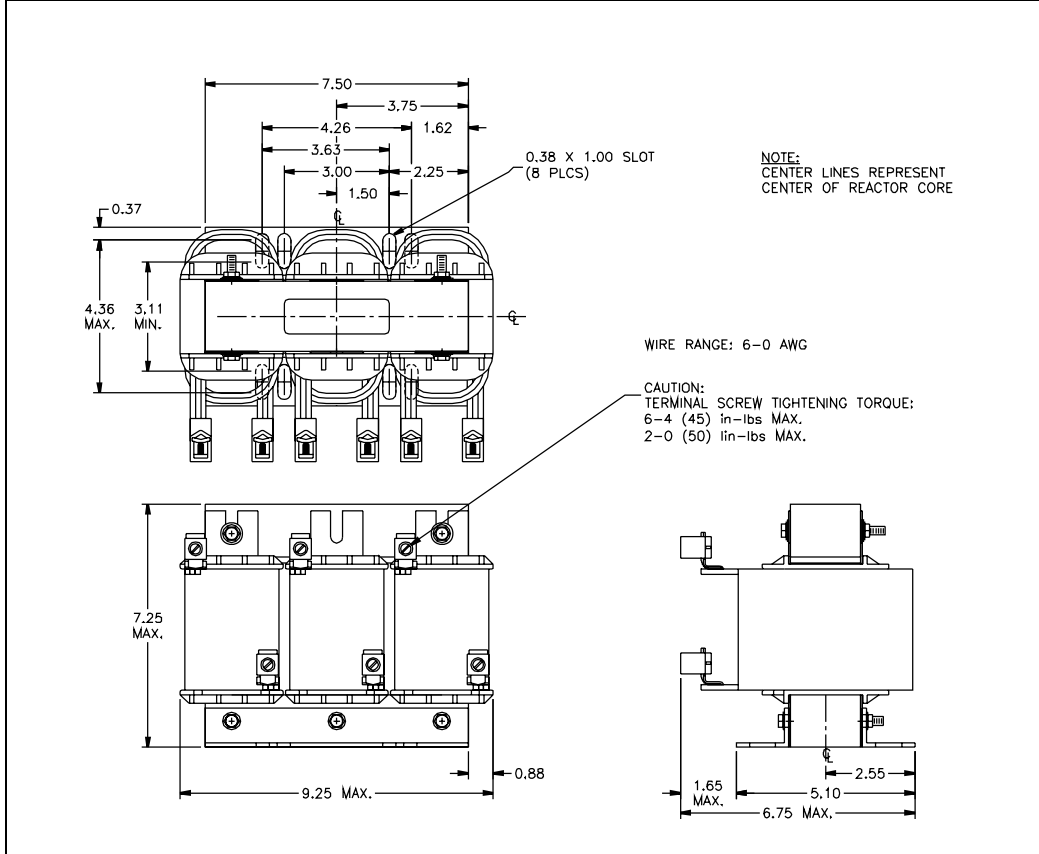


Table 4-10: MMC-SD-65-460 Line Reactor Specifications				
Fundamental Amperage	Power Loss	Inductance	Weight	Part Number
130A	180W	0.2 mH	57 lbs.	M.3000.0108

0.38 x 1.00 (8 SLOTS)

WIRE RANGE: 2-0000 AWG

CAUTION: TERMINAL SCREW TIGHTENING TORQUE: 150 in-lb MAX.

NOTE: CENTER LINE REPRESENTS CENTER OF REACTOR CORE

Dimensions shown in drawing: 3.75, 7.50, 4.26, 1.62, 3.63, 3.00, 2.25, 1.50, 0.37, 4.36 MAX., 3.11 MIN., 7.13 MAX., 9.25 MAX., 0.88, 1.65 MAX., 5.10, 6.75 MAX., 2.55.

#### 4.4 Isolation Transformers

The MMC Smart Drive does not require the use of isolation transformers. However, a transformer may be required to match the voltage requirements of the controller to the available service. To size a transformer for the main AC power inputs, the power output (KVA) of each axis must be known. This can be derived by calculating the horsepower for each axis and converting that horsepower into units of watts. If power is being supplied to more than one motor and a drive, simply add the kW ratings together from each calculation to get a system kW total.

For an autotransformer, ensure that the phase to neutral/ground voltages do not exceed the input voltage ratings of the drive.

If you are using the Motions Solutions Sizing Software, the average speed and average torque data has already been calculated and can be used in the equation. If you are not sure of the exact speed and torque in your application, record the speed/torque curve for your drive/motor combination and use the resulting values as a worst case continuous speed and torque.

Calculations are multiplied by a factor to compensate for the power and loss elements within a power system. A factor of 2.0 is used with a single phase system and a factor of 1.5 is used with a three phase system. This factor should minimize the effects of the secondary line voltage sagging in the transformer during peak current periods.

The speed/torque curve information for 230V motors is based upon a drive input voltage of 230V AC. For a 115V AC input voltage, the maximum speed can be reduced up to one half.

**Example 230V Formula:**

$$KVA = \frac{Speed(RPM) \cdot Torque(lb - in)}{63,025} \cdot \frac{0.746 \cdot KVA}{HP} \cdot 2.0$$

**Example 460V Formula:**

$$KVA = \frac{Speed(RPM) \cdot Torque(lb - in)}{63,025} \cdot \frac{0.746 \cdot KVA}{HP} \cdot 1.5$$

**NOTE**

The 3-Phase source powering the drive has to be a center-grounded "Y" configuration. Do not exceed 304 Volts RMS from any phase to ground.

## 4.5 External Shunts

### 4.5.1 Choosing an External Shunt

Power from the motor is returned to the MMC Smart Drive during motor deceleration. Excessive power may have to be dissipated from the MMC Smart drive when large inertia loads are present. External shunts should be used to avoid excessive bus over voltage faults.

Danaher Motion recommends you use the Motion Solutions Sizing Software to determine the need for and type of external shunt. However, you may perform the following calculations to choose the external shunt for your application.

1. Obtain the Peak Generating Power for the drive in watts (W).
2. Perform the following calculation:  

$$W \times T = \text{Watts/sec or Joules}$$
 where:  

$$W \text{ is watts from Step 1 above,}$$

$$T \text{ is decel time required by the application}$$
3. Obtain the Absorption Energy in Joules for the drive from the Specifications section of the drive manual.
4. Determine the Peak Shunt Power from the drive that would be delivered to the shunt resistor for your application:



- (Number calculated in Step 2 above) - (Absorption Energy from the drive Specifications table in either Chapter 5 or 6)  
= Watt-seconds
  - (Watt-seconds computed in 5a. above) ÷ (Decel Time for the application) = Peak Shunt Power in Watts
5. Determine the Continuous Shunt Power that would be delivered to the shunt resistor for this application:
- Duty Cycle of Peak or Peak x Decel Time) ÷ (Total Cycle Time) = Continuous Shunt Power in Watts
6. Choose an external shunt from [Table 4-11](#).

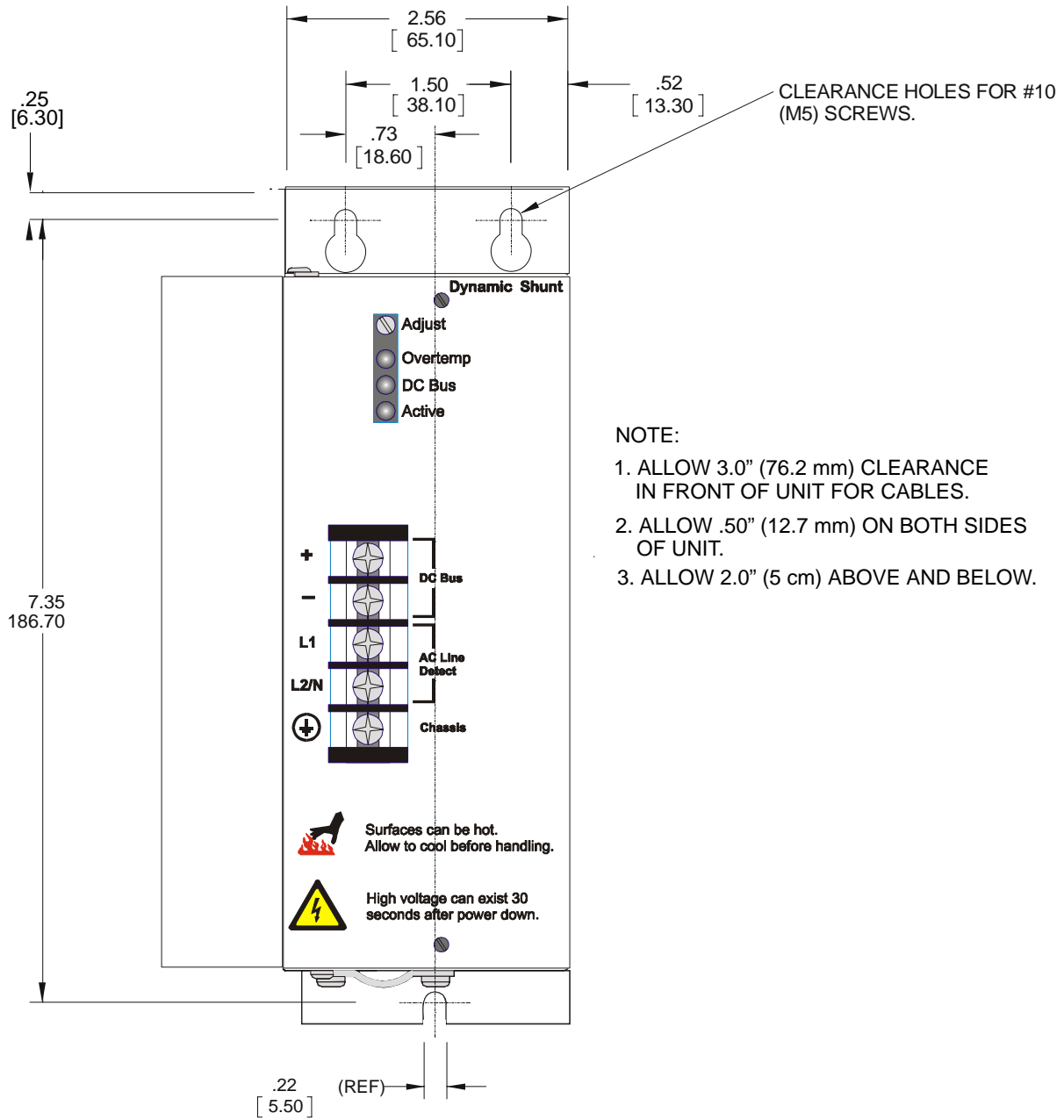
**4.5.2 External Shunt Resistor Kits**

<b>Table 4-11: Shunt Resistors</b>		
<b>For Drive<sup>a</sup></b>	<b>Shunt Resistor Module</b>	<b>Part Number</b>
MMC-SD-0.5-230 MMC-SD-1.0-230 MMC-SD-2.0-230	100Ω, 300W, 600V, Dynamic	M.1015.7046
MMC-SD-1.3-460 MMC-SD-2.4-460	130Ω, 450W Cont. Power, 5.4kW Peak Power, 820 V, 240 sec. Time Constant, 121 mm x 93 mm x 605 mm	M.1302.7048
MMC-SD-4.0-460	95Ω, 700W Cont. Power, 8kW Peak Power, 820 V, 250 sec. Time Constant, 121 mm x 93 mm x 705 mm	M.1302.7049
MMC-SD-6.0-460 MMC-SD-8.0-460	50Ω, 1400W Cont. Power, 17kW Peak Power, 850V, 250 sec. Time Constant, 130 mm x 182 mm x 710 mm	M.1302.7060
MMC-SD-12.0-460 MMC-SD-16.0-460	25 Ω, 2800W Cont. Power, 32kW Peak Power, 850V, 60 sec. Time Constant, 171 mm x 430 mm x 550 mm	M.1302.7061
MMC-SD-24.0-460 MMC-SD-30.0-460 MMC-SD-42.0-460 MMC-SD-51.0-460 MMC-SD-65.0-460	18Ω, 3900W Cont. Power, 70kW Peak Power, 850V, 70 sec. Time Constant, 180 mm x 445 mm x 490 mm	M.1302.7063

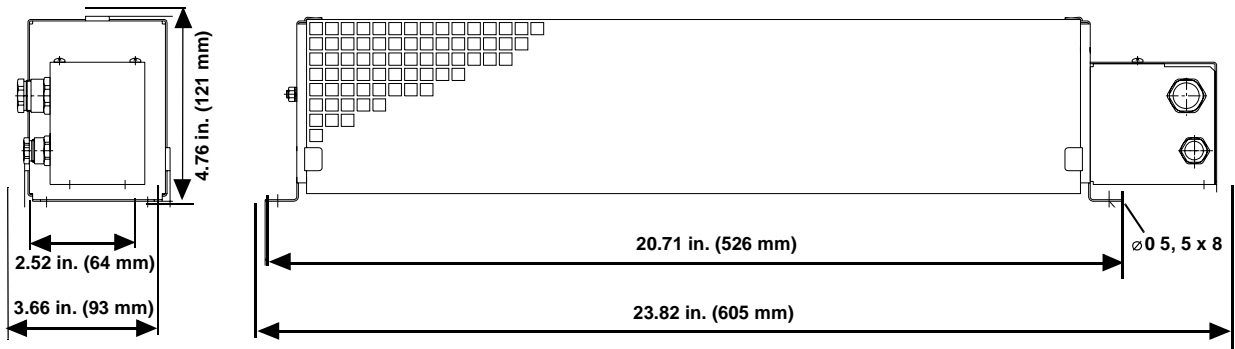
a. Drive Model pertains to Analog (no dash suffix) and digital (-D)

### 4.5.3 Mounting Dimensions for External Shunts

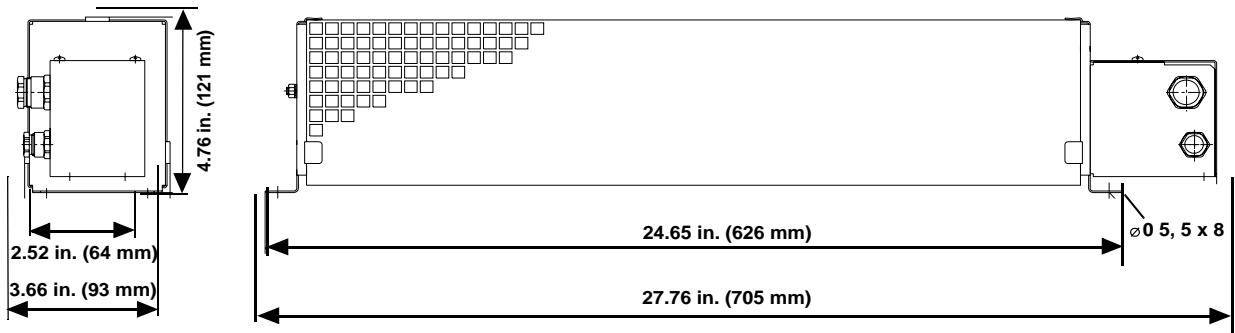
Figure 4-2: Mounting Dimensions for 230V External Shunt (P/N M.1015.7046)



**Figure 4-3: Mounting Dimensions for 460V External Shunt (P/N M.1302.7048)**



**Figure 4-4: Mounting Dimensions for 460V External Shunt (P/N M.1302.7049)**



**Figure 4-5: Mounting Dimensions for 460V External Shunt (P/N M.1302.7060)**

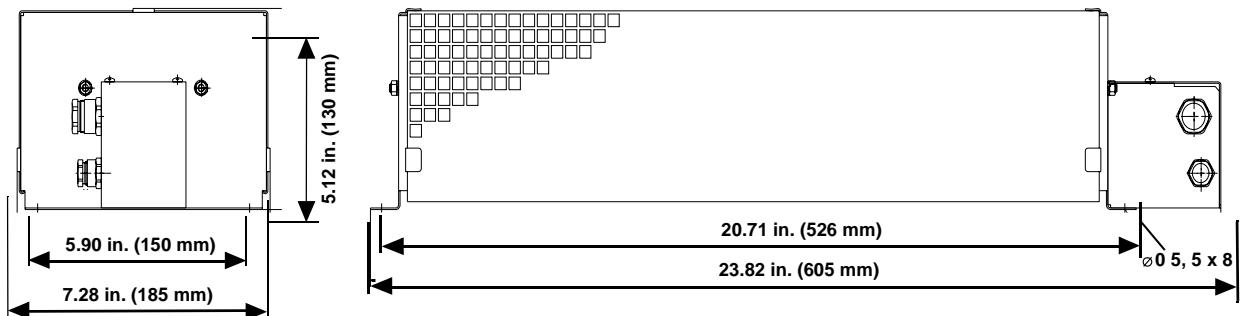
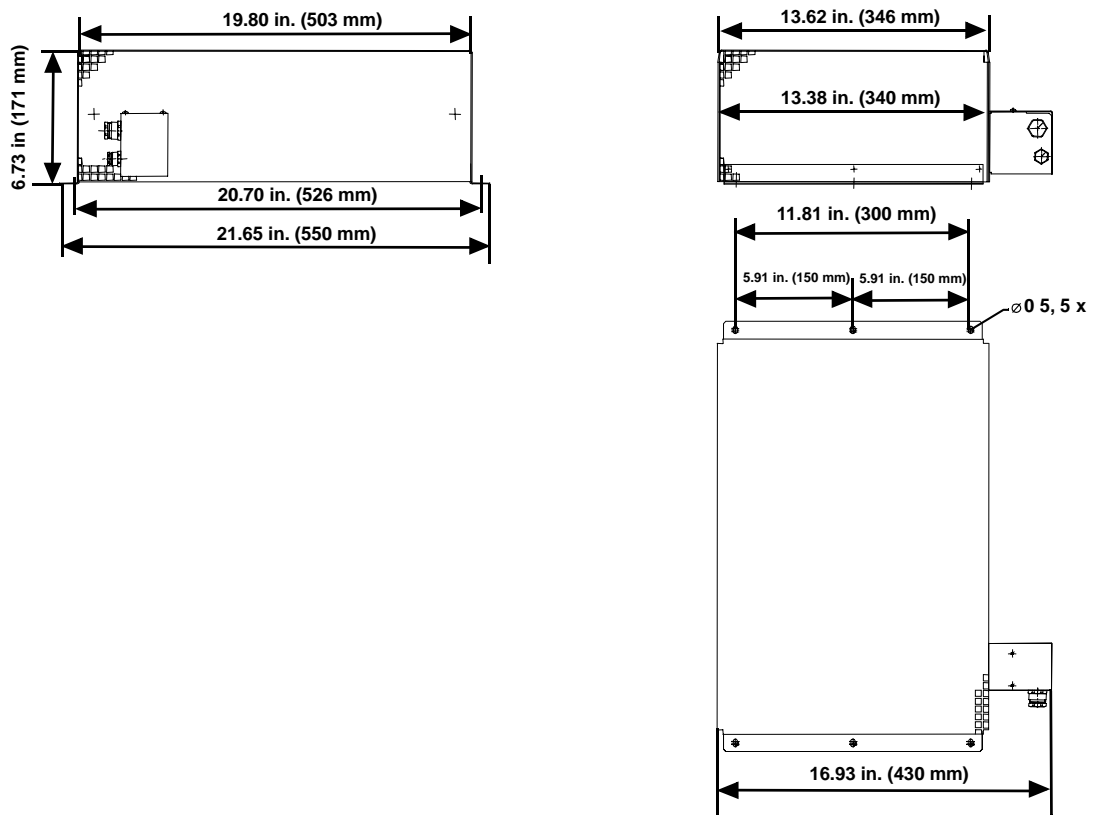
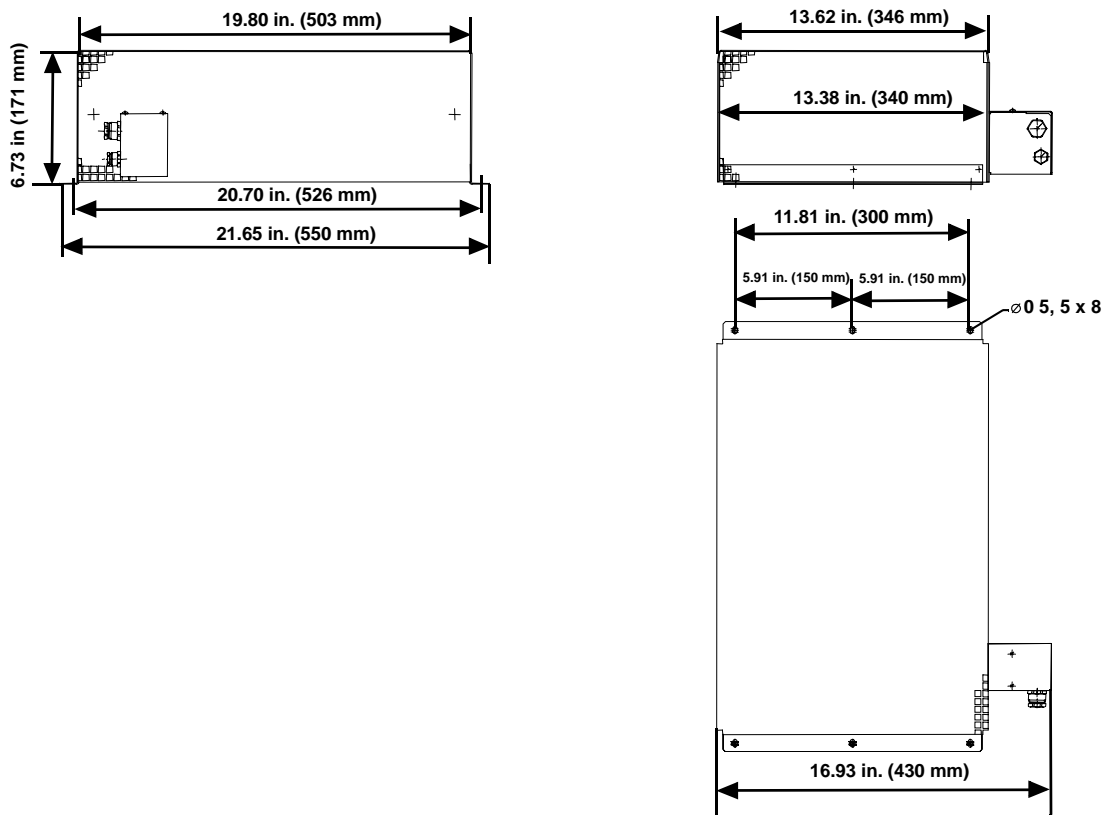


Figure 4-6: Mounting Dimensions for 460V External Shunt (P/N M.1302.7061)



**Figure 4-7: Mounting Dimensions for 460V External Shunt (P/N M.1302.7063)**

## 4.6 Line Filters

Line Filters consist of combinations of capacitors, reactors, resistors and voltage limiters that are intended to reduce the electromagnetic influence of the environment.

### 4.6.1 Line Filters and CE Compliance

The direction of influence is bi-directional, i.e. there is a reaction in the units of emission of conducted disturbances, and, at the same time, an improvement in the immunity of the drive to interference that occurs in the case of lightning strikes, tripped fuses, or simple switching activities.

- The filter should be mounted to a grounded conductive surface.
- The filter must be mounted close to the drive input terminals. If the distance exceeds 2 feet (600 mm), then a shielded cable should be used to connect the drive and filter, rather than a wire.
- The wires connecting the AC source to the filter should be shielded from, or at least separated from the wires (or strap) connecting the drive to the filter. If the connections are not segregated from each other, then the EMI on the drive side of the filter can couple over to the source side of the filter, thereby reducing, or eliminating the filter effectiveness. The coupling mechanism can be radiation, or stray capacitance between the wires.

Figure 4-8: Block Diagram Simplified for 3-Phase Line Filter

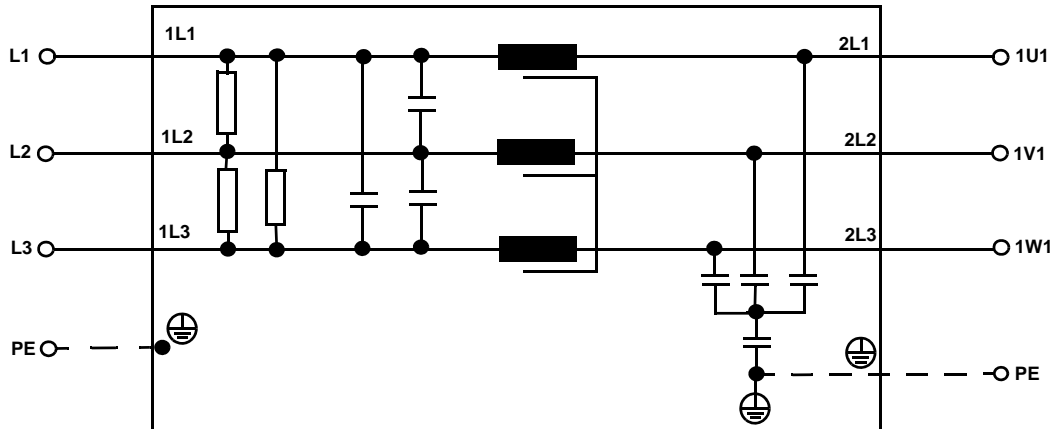
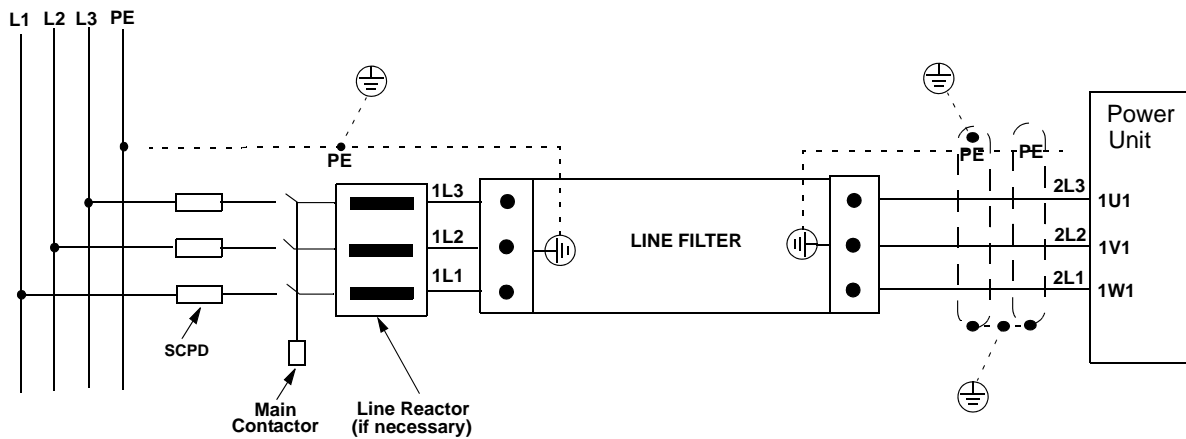



Figure 4-9: Connection Diagram for 3-Phase Line Filter



<b>WARNING</b>	
	<p>High leakage currents exist in AC line filters. The filters must be grounded properly before applying power. Filter capacitors retain high voltages after removal. Measure voltages to determine safe levels prior to handling the equipment. Failure to do so could result in severe bodily injury.</p>

<b>NOTE</b>
<p>To be able to route the interference currents at low impedance back to the interference sources, the filter, the power unit, and the contact area of the motor cable shield must have a junction with the common mounting plate over as wide a surface as possible that has good conductive properties. The best way to ensure this is to use unpainted zinc-coated mounting plates.</p>

<b>Table 4-12: Part Numbers for AC Line Filters</b>		
<b>Current</b>	<b>For Drive</b>	<b>Part Number</b>
6A, 250V, 1 Phase	MMC-SD-0.5-230 MMC-SD-1.0-230	M.1015.6922
10A, 250V, 1 Phase	MMC-SD-2.0-230	M.1015.6917
7A, 480V, 3 Phase	MMC-SD-1.3-460 MMC-SD-2.4-460	M.1302.5241
16A, 480V, 3 Phase	MMC-SD-4.0-460 MMC-SD-6.0-460 MMC-SD-8.0-460	M.1302.5244
30A, 480V, 3 Phase	MMC-SD-12.0-460 MMC-SD-16.0-460	M.1302.5245
42A, 480V, 3 Phase	MMC-SD-24.0-460	M.1302.5246
56A, 480V, 3 Phase	MMC-SD-30.0-460 MMC-SD-42.0-460	M.1302.5247
75A, 480V, 3 Phase	MMC-SD-51.0-460	M.1302.5248
100A, 480V, 3 Phase	MMC-SD-65.0-460	M.3000.0109

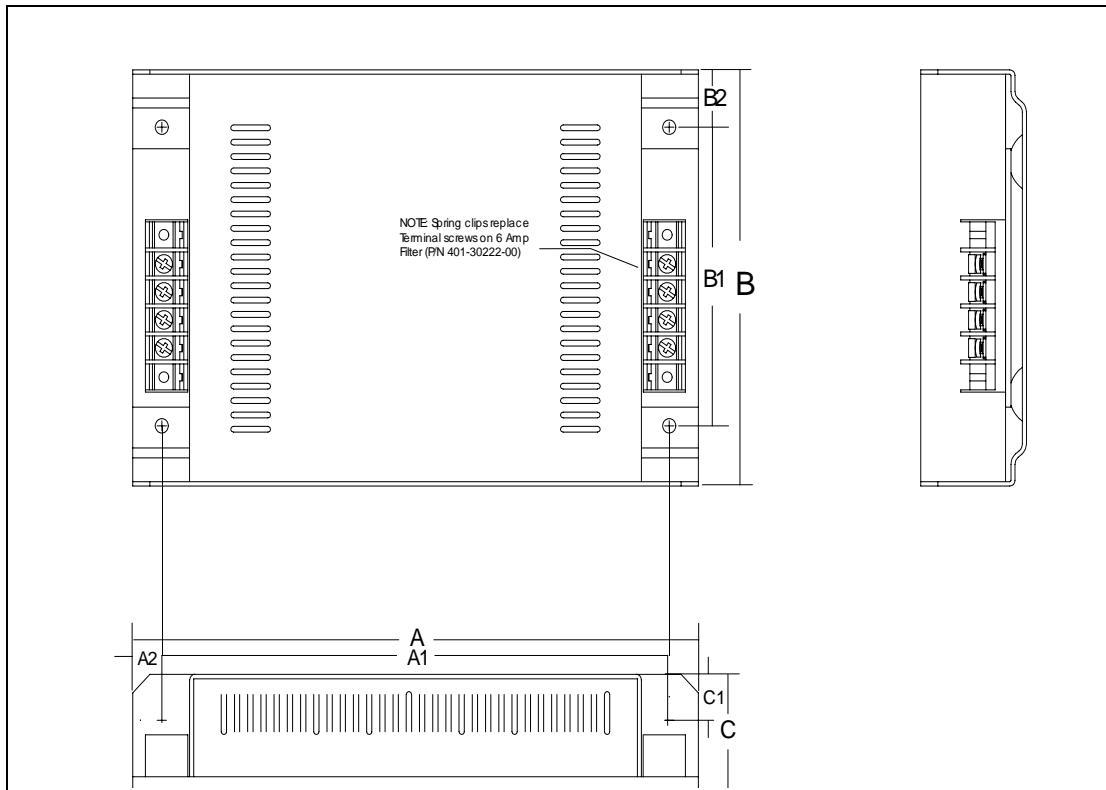
<b>Table 4-13: Technical Data for 230V Line Filters</b>			
	<b>M.1015.6922</b>	<b>M.1015.6917</b>	<b>M.1015.6918</b>
Voltage/Freq.	250VAC @ 50/50Hz	250VAC @ 50/50Hz	250VAC @ 50/50Hz
Current	6A @ 50°C	10A @ 50°C	23A @ 50°C
Overload Current	150% 1 minute 200% 1 second	150% 1 minute 200% 1 second	150% 1 minute 200% 1 second
Temperature	-25 to 95°C	-25 to 95°C	-25 to 95°C
Leakage Current	5mA @ 240V, 50 Hz	46mA @ 240V, 50 Hz	200mA @ 250V, 50Hz
Electric Strength	2500VAC/1 minute	2500VAC/1 minute	2500VAC/1 minute
Power Loss	3.5W (Full Load)	2.7W (Full Load)	10W (Full Load)
Terminals	2mm sq. spring clamp	M4 screw cross/ sq. 2x 2.5mm	M4 screw cross/ sq. 2x 2.5mm
Weight	0.3Kg (0.66 Lb.)	0.95Kg (2.0 Lb)	1.6Kg (2.5 Lb)
Back Mounting <sup>a</sup>	4 x M4	4 x M4	4 x M4
Side Mounting <sup>a</sup>	2 x M5	2 x M6	2 x M6

a. Line filters are manufactured to millimeter dimensions (inches are approximate conversions).



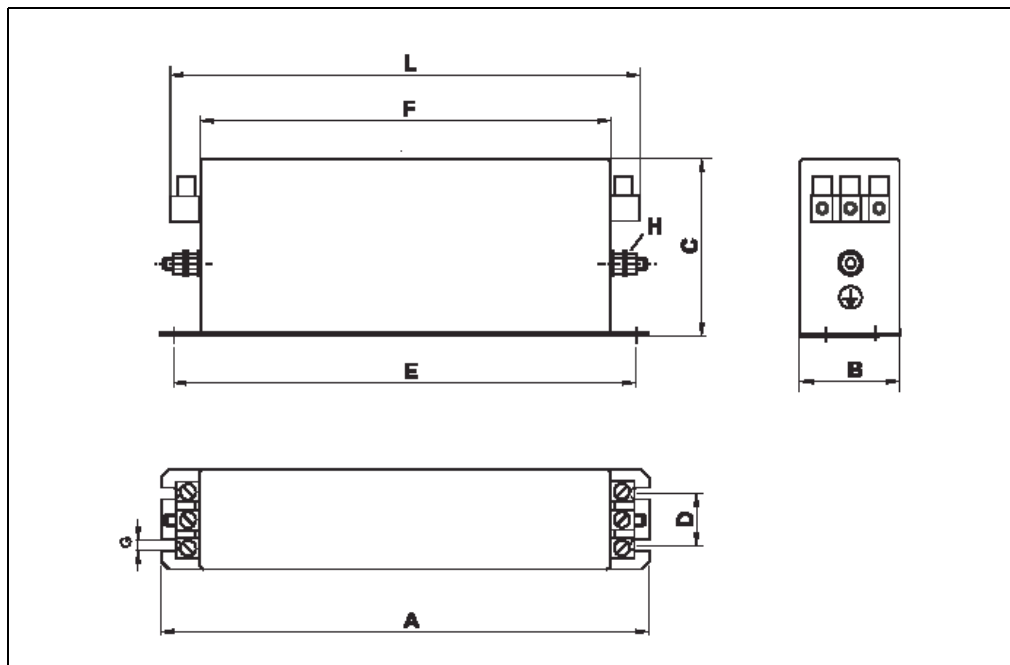
Table 4-14: Technical Data for 460V Line Filters							
Item	Part Number						
	M.1302.5241	M.1302.5244	M.1302.5245	M.1302.5246	M.1302.5247	M.1302.5248	M.3000.0109
Maximum Supply Voltage	3 x 480VAC, 50/60Hz						
Rated current (at 40°C)	7A	16A	30A	42A	56A	75A	100A
Peak current	1.5 x I <sub>N</sub> for < 1 min. per hour at T <sub>B</sub> = 40°						
Test Voltage Phase/Phase Phase/Ground	2.1 kVDC for 2 sec. at 25°C 2.7 kVDC for 2 sec. at 25°C						
Maximum Connection Cross-section	4mm <sup>2</sup>	4mm <sup>2</sup>	10mm <sup>2</sup>	10mm <sup>2</sup>	4mm <sup>2</sup>	25mm <sup>2</sup>	50mm <sup>2</sup>
Operational Environmental Temperature Range T <sub>B</sub>	-25°C ... +55°C Reduction of rated current from 40°C onwards by 1.4% / °C						
Power Loss (typical)	4W	8W	12W	15W	18W	24W	24W
Site Altitude	Below 2000 m above sea level (higher altitudes on request)						
Storage Temperature Range	-25°C ... +85°C						
Type of Protection	IP20						
Weight	0.6kg	1.0kg	1.3kg	1.6kg	1.9kg	2.6kg	4.0kg

4.6.2 Dimensions for 230V Line Filters



MEASUREMENT	SINGLE PHASE 6A M.1015.6922		SINGLE PHASE 10A M.1015.6917		SINGLE PHASE 23A M.1015.6918	
	mm	in	mm	in	mm	in
A	170	6.7	214	8.4	214	8.4
A1	152	6.0	192	7.6	192	7.6
A2	9	0.4	11	0.4	11	0.4
B	92	3.6	145	5.7	204	8.0
B1	55	2.2	104	4.1	164	6.6
B2	18	0.7	20	0.8	20	0.8
C	25	1.0	40	1.6	47	1.8
C1	10	0.4	16	0.6	19	0.8

4.6.3 Dimensions for 460V Line Filters



Part Number	A	B	C	D	E	F	L	G	H
M.1302.5241	190	40	70	20	180	160	185	5.4	M5
M.1302.5244	250	50	70	25	235	220	245		
M.1302.5245	270	50	85	30	255	240	265		
M.1302.5246	310	50	85	30	295	280	305	6.5	M6
M.1302.5247	250	85	90	60	235	220	258		
M.1302.5248	270	80	135	60	255	240	278		
M.3000.0190	270	90	150	65	255	240	326	6.5	M10



## 5 230V Single Phase MMC Smart Drive

### 5.1 LEDs

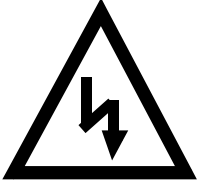
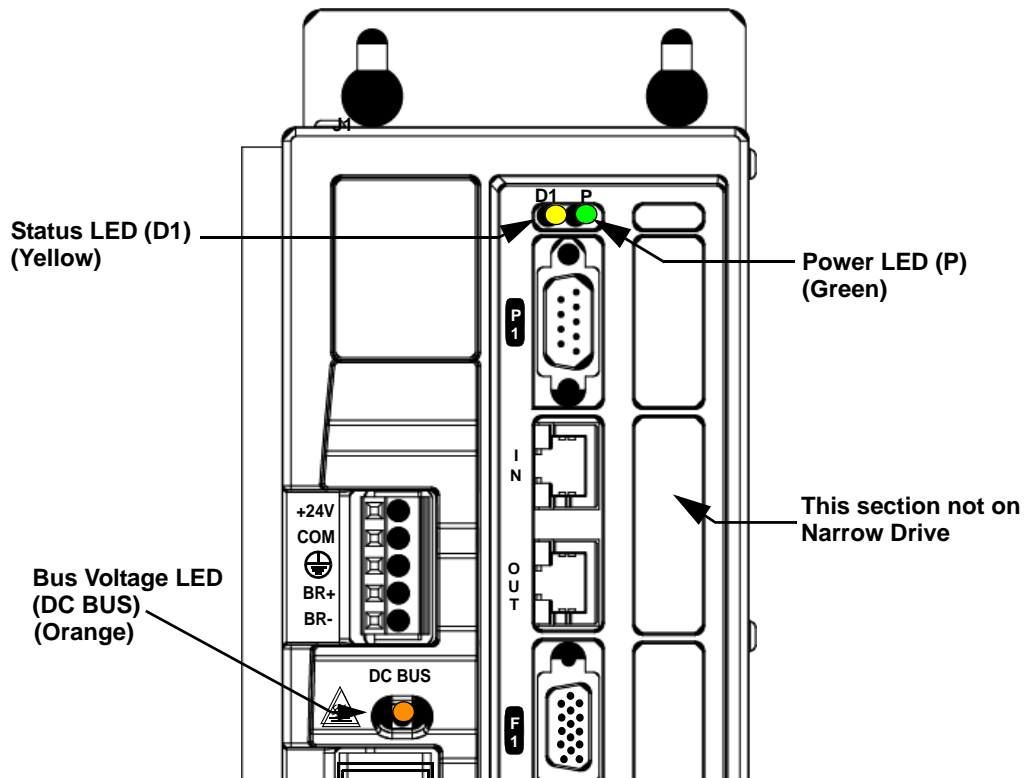
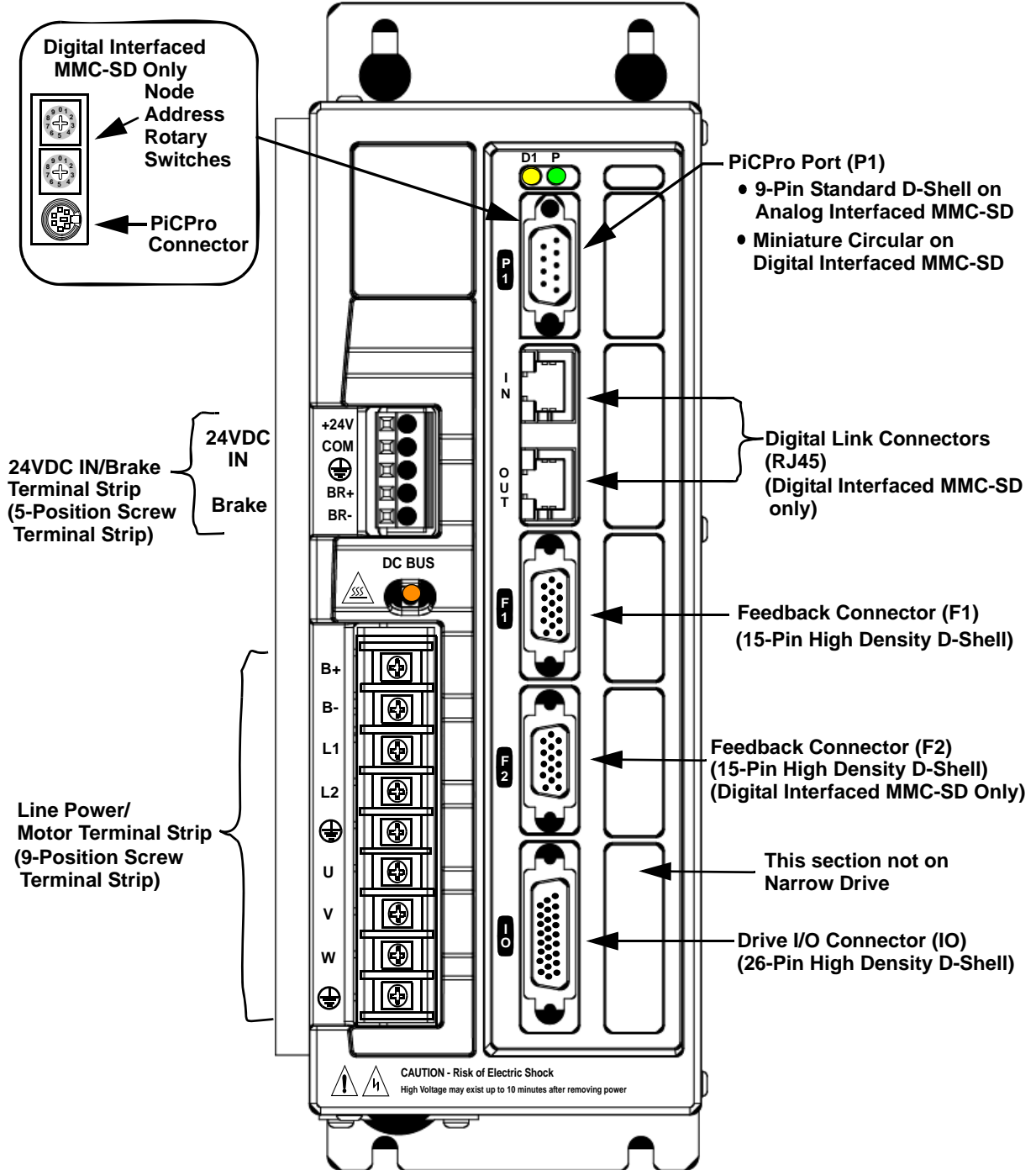
Table 5-1: LEDs Description for 230V Single Phase MMC Smart Drive		
LED	Color	Description
P	Green	Power LED. Indicates when illuminated that power is being supplied to the 24V input terminal strip.
D1	Yellow	Status LED. Drive status and fault information.
<p>DC BUS</p> 	Orange	<p>Bus Voltage LED. Indicates when illuminated that the DC bus is at a hazardous voltage.</p> <p><b>DANGER</b></p> <p>DC bus capacitors may retain hazardous voltages for up to ten minutes after input power has been removed. Always use a voltmeter to ensure that the DC bus voltage is below 50VDC before servicing the drive. Failure to observe this precaution could result in severe bodily injury or loss of life.</p>

Figure 5-1: Location of LEDs on 230V Single Phase MMC Smart Drive



5.2 Connectors and Switches on the 230V Drive

Figure 5-2: Front Panel, 230V Single Phase (500W, 1kW, 2 kW)



### 5.2.1 PiCPro Port (Digital Interfaced Drives)

This section details the PiCPro Port connector on the Digital Interfaced Drives (-D and -DN). For information on the PiCPro Port connector on Analog Interfaced Drives, see [section 5.2.2 on page 65](#).

The 6-pin circular DIN PiCPro Port connector (labeled “P1” on the front of the Drive) provides serial communication for the PiCPro programming interface.

- Pin descriptions for are provided in [Table 5-2](#)
- Pin assignments are provided in [Table 5-3](#)
- The available PiCPro Port to PC cable is described in [Table 5-4](#)

**Table 5-2: PiCPro Port Pin Descriptions**

Function	Notes	Pin
Receive Data	RS232-level signal that receives serial data from the connected PC running PiCPro.	1
Transmit Data	RS232-level signal that transmits serial data to the connected PC running PiCPro.	2
Signal Ground	Provides the return path for signals	3 and 5
Shield Ground	Provides a path for shield current through the chassis to an external single point ground.	Connector Shell

**Table 5-3: PiCPro Port Pin Assignments**

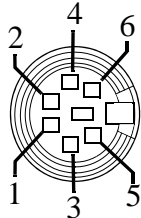
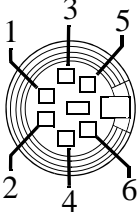
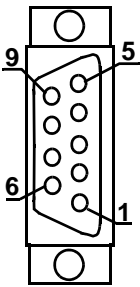
Pin	Signal	In/Out	Connector Pinout
1	RS232 Receive Data	In	<p>6-pin Female Miniature Circular DIN</p> 
2	RS232 Transmit Data	Out	
3	Signal Ground	In/Out	
4	NC	N/A	
5	Signal Ground	In/Out	
6	NC	N/A	
Connector Shield	Shield	In	



Table 5-4: PiCPr0 Port to PC Cable				
Part Number: M.1302.8284 Length: 4 M (13 ft) Cable type: 24 AWG, shielded, twisted pair, 4 conductor.				
6-Pin male Miniature Circular DIN (to PiCPro Port, face view)		9-Pin female D-sub (to PC COM Port, face view)		
				
Pin	Signal	Pin	Signal	Notes
1	RS232 Receive Data	3	RS232 Transmit Data	Twisted Pair
2	RS232 Transmit Data	2	RS232 Receive Data	
5	Signal Ground	5	Signal Ground	
Shell	Drain	Shell	Drain	

### 5.2.2 PiCPro Port (Analog Drives)

This section details the PiCPro Port connector on the Analog Interfaced Drives (not -D or -DN). For information on the PiCPro Port connector on Digital Interfaced Drives, see [section 5.2.1 on page 64](#).

The 9-pin male D-sub PiCPro Port connector (labeled “P1” on the front of the Drive) provides serial communication for the PiCPro programming interface.

- Pin descriptions for are provided in [Table 5-5](#)
- Pin assignments are provided in [Table 5-6](#)
- The available PiCPro Port to PC cable is described in [Table 5-7](#)

**Table 5-5: PiCPro Port Pin Descriptions**

Function	Notes	Pin
Receive Data	RS232-level signal that receives serial data from the connected PC running PiCPro.	2
Transmit Data	RS232-level signal that transmits serial data to the connected PC running PiCPro.	3
Signal Ground	Provides the return path for signals	5
Data Terminal Ready	Always high (tied to +12V through 1K resistor)	4
Request-to-send	Always high (tied to +12V through 1K resistor)	7
Shield Ground	Provides a path for shield current through the chassis to an external single point ground.	Connector Shell

**Table 5-6: PiCPro Port Pin Assignments**

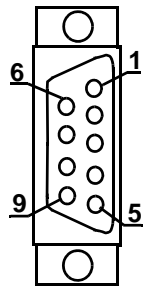
Pin	Signal	In/Out	Connector Pinout
1	NC	N/A	<p>9-pin male D-sub</p> 
2	RS232 Receive Data	In	
3	RS232 Transmit Data	Out	
4	Data Terminal Ready	Out	
5	Signal Ground	In/Out	
6	NC	N/A	
7	Request-to-send	Out	
8	NC	N/A	
9	NC	N/A	
Connector Shield	Drain	In	

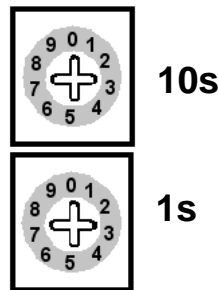
Table 5-7: PiCPr0 Port to PC Cable				
Part Number: M.1302.8250 Length: 4 M (13 ft) Cable type: 24 AWG, shielded, twisted pair, 4 conductor.				
9-Pin female D-sub (to PiCPro Port, face view)		9-Pin female D-sub (to PC COM Port, face view)		
Pin	Signal	Pin	Signal	Notes
2	Receive Data	3	Transmit Data	Twisted Pair
3	Transmit Data	2	Receive Data	
5	Signal Ground	5	Signal Ground	
Shell	Drain	Shell	Drain	

### 5.2.3 Node Address Rotary Switch (Digital Interfaced MMC-SD Only)

Two rotary switches are used to set the drive address. Rotate the switch to the desired address.

Addresses can be set to any number from 1 through 64. The top switch represents values of base ten. The bottom switch represents values of base 1.

As an example, rotating the switch to a setting of 2 on the top switch equals the value of 20 (2 x 10). Rotating the switch on the bottom switch to a setting of 5 equals the value of 5. The actual address setting is 25 (20 + 5).



## 5.2.4 Digital Link Ports (Digital Interfaced MMC-SD Only)

The two 8-pin RJ-45 Digital Link Port connectors (labeled “IN” and “OUT” on the front of the Drive) provide communications between Drives and between a Drive and a Standalone MMC Digital Control. Also provided are two green “Link” lights located between the RJ-45 connectors. The left light will be on if there is a Drive or Digital Control connected to the “IN” port, and the right light will be on if there is a Drive connected to the “OUT” port.

A “straight-through” shielded cable must be used when connecting the Drive to either the Standalone MMC Digital Control or another Drive. Connect the cable from the Drive’s “OUT” port to the next Drive’s “IN” port, or from the Standalone MMC Digital Control’s “B” port to the Drive’s “IN” port. Refer to the Standalone MMC Hardware Manual for Control information.

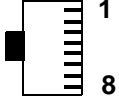

- Pin descriptions for are provided in [Table 5-8](#)
- Pin assignments are provided in [Table 5-9](#)
- The available Digital Link Port to Digital Drive cables are described in [Table 5-10](#)

**Table 5-8: Digital Link Port Pin Description**

Digital Link Connector (IN/OUT) Signals		Pin	
Function	Notes	“In” Connector	“Out” Connector
Receive Data +	Receives data from connected drives.	1	3
Receive Data -	Receives data from connected drives.	2	6
Transmit Data +	Transmits data to connected drives.	3	1
Transmit Data -	Transmits data to connected drives.	6	2
Protective Ground	Provides a path for the ground signal to an external single point ground.	Connector Shell	Connector Shell

Table 5-9: Digital Link Port Pin Assignments			
Pin	Label	In/Out	Connector Pinout
<b>IN Connector</b>			
1	Receive +	In	<p>RJ-45 Connectors</p>
2	Receive -	In	
3	Transmit +	Out	
4	Not Used	N/A	
5	Not Used	N/A	
6	Transmit -	Out	
Connector Shield	Provides a path for the ground signal to an external single point ground.	In	
<b>OUT Connector</b>			
1	Transmit +	Out	
2	Transmit -	Out	
3	Receive +	In	
4	Not Used	N/A	
5	Not Used	N/A	
6	Receive -	In	
Connector Shield	Provides a path for the ground signal to an external single point ground.	In	

**Table 5-10: Digital Link Port “IN” to “OUT” Cables**

Part Numbers:				
.3 M (1.0 ft): M.1302.8285		.6 M (2.0 ft): M.1302.8286		
1 M (3.3 ft): M.1302.8287		2 M (6.6 ft): M.1302.8288		
3 M (9.8 ft): M.1302.8289		5 M (16.4 ft): M.1302.8300		
10 M (32.8 ft): M.1302.8301		15 M (49.2 ft): M.1302.8302		
30 M (98.4 ft): M.1302.8303				
Cable type: 28 AWG, shielded, twisted pair, 8 conductor.				
8-Pin RJ-45 Plug (to Digital Link Port “OUT”, face view)		8-Pin RJ-45 Plug (to Digital Drive “IN”, face view)		
				
Pin	Signal	Pin	Signal	Notes
1	Transmit Data +	1	Receive Data +	Twisted
2	Transmit Data -	2	Receive Data -	Pair
3	Receive Data +	3	Transmit Data +	Twisted
6	Receive Data -	6	Transmit Data -	Pair
4	None	4	None	Twisted
5	None	5	None	Pair
7	None	7	None	Twisted
8	None	8	None	Pair
Shell	Drain	Shell	Drain	

### 5.2.5 Feedback Connector (F1)

- All signals (other than the encoder inputs) are bussed internally between the two feedback connectors F1 and F2. The bussed signals include motor commutation inputs, temperature input, and encoder power outputs.
- F1 can interface with incremental encoders, sinewave encoders, and resolvers (using the optional resolver interface module). These signals are conditioned and routed to the Drive I/O connector.

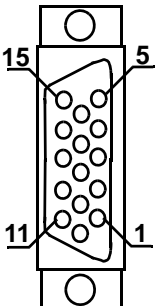
#### NOTE

Because of the variety of feedback devices that can be used, the following table contains signal descriptions only (no pin numbers). Refer to [Table 5-12](#) for feedback device specific pin numbers.

**Table 5-11: Pin Description for Feedback Connector (F1)**

F1 Feedback Signals			
Signal Type	Signal Name	Notes	Pin
Incremental Encoder Inputs	A1, A1/, B1, B1/, I1, I1/	Differential A quad B encoder signals.	Pin Assignments vary depending on the type of Feedback Device used. Refer to <a href="#">Table 5-12</a> for pin assignments.
Sinewave Encoder Inputs	Sin, Sin/, Cos, Cos/	Sinewave Encoder signals	
Sinewave Encoder Data Channel In/Out	RS-485 Data +, RS-485 Data -, RS-485 Clock+, RS-485 Clock-	RS-485 signals for connecting the Sinewave Encoder Data Channel to the drive	
Motor Commutation Hall Sensor Inputs	Commutation Track S1, S2, S3	Hall device input signals that are used to initialize the commutation angle. They consist of a 74HC14 input with 10µs filter and 1 K pull up to +5V. Shared with F2.	
Sinewave Encoder Commutation Inputs	Commutation Sin+, Commutation Sin-	Sinewave signals that are used to initialize the motor commutation angle when a Heidenhein Sincoder is used as the motor feedback device.	
Resolver Inputs	Sin+, Sin-, Cos+, Cos-	Resolver rotor feedback signals used when optional Resolver Interface Board is installed.	
Resolver Outputs	Carrier+, Carrier-	Resolver rotor excitation signals used when optional Resolver Interface Board is installed.	
Temperature Input	Temperature	Thermostat (normally- closed) or Thermistor (Phillips KTY84-130 PTC or equivalent recommended) input for detecting over temperature conditions within the motor.	
Travel Limit Inputs	+ Travel Limit, -Travel Limit	Over travel limit inputs (Reserved for future use).	
Encoder Power Outputs	+5V Source, +9V Source	Regulated +5VDC and regulated +9VDC for powering the attached encoder.	
Sinewave Encoder Reference Mark Input	Ref Mark/	Reference Mark input used with some Sinewave Encoders used to indicate motor position within one revolution.	
Signal and Power Common	Common	Return path for feedback signals and power supplies (+5V and +9V).	

**Table 5-12: Encoder/Resolver Pin Assignments for Feedback Connector (F1)**

Encoder/Resolver Pin Assignments for Motor Feedback 15 Pin Connector (F1) 230V Single Phase (500W, 1kW, 2kW)							
Pin	Feedback Device					In/ Out	Connector Pinout
	Digital Incremental	Stegmann Hiperface	Sinewave Encoder		Resolver <sup>d</sup>		
			Endat <sup>a</sup> BISS <sup>a,b</sup> SSI <sup>a,c</sup>	Heidenhain Sincoder <sup>c</sup>			
1	A1	Cos		Cos+	In	15-pin Female HD D-Sub  	
2	A1/	Cos/		Cos-			
3	B1	Sine		Sin+			
4	B1/	Sine/		Sin-			
5	I1	RS-485 Data+		Ref Mark	Carrier+		Note <sup>e</sup>
6	Common						In/Out
7	N/U	+9V Source	N/U	N/U	N/U		Out
8	Commutation Track S3	N/U	N/U	N/U	N/U		In
9	+ Travel Limit		Commuta- tion Cos+	+Travel Limit			
10	I1/	RS-485 Data-		Ref Mark/	Carrier-		Note <sup>e</sup>
11	Temperature						In
12	Commutation Track S1	N/U	RS-485 Clock+	Commuta- tion Sin+	N/U		In <sup>f</sup>
13	Commutation Track S2	N/U	RS-485 Clock-	Commuta- tion Sin-	N/U		
14	+5V Source	N/U	+5V Source		N/U		Out
15	- Travel Limit		Commuta- tion Cos-	-Travel Limit	In		
Shell	Shield					N/A	

a. Available on Digital Interfaced MMC-SD only

b. Not on all Part Numbers. See [Chapter 11](#) for details

c. For future use

d. Requires installation of optional resolver board.

e. Pins 5 and 10 are In/Out for Stegmann Hiperface and Endat; Inputs for Digital Incremental, SSI, BiSS, Heidenhain Sincoder; and Outputs for Resolver

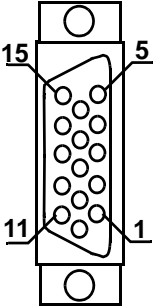
f. Pins 12 and 13 are Outputs for ENDAT, SSI, and BiSS



### 5.2.6 Feedback Connector (F2) (Digital Interfaced MMC-SD Only)

- All motor signals (other than the encoder inputs) are bussed internally between the two feedback connectors F1 and F2. The bussed signals include motor commutation inputs, temperature input, travel limit inputs, and encoder power outputs.
- F2 can be designated (in PiCPro) as the motor feedback connector but only if F1 is not (either one or the other must be designated as such).
- Travel Limits can be defined in PiCPro software as either coming into the MMC Smart Drive at the F2 connector or at the Drive I/O connector.
- F2 can interface with only incremental type encoders.
- The hall sensor inputs on F1 and F2 are connected together, allowing either F1 or F2 to accept the hall sensor signal, but NOT both. Only one feedback may be connected to motor hall sensor inputs.

<b>F2 Feedback Signals</b>		
<b>Signal Type</b>	<b>Notes</b>	<b>Pins</b>
Incremental Encoder Input	Differential A quad B encoder signals.	1, 2, 3, 4, 5, 10
Motor Commutation Hall Sensor Inputs	Hall-device input signals that are used to initialize the motor commutation angle. They consist of a 74HC14 input with a 10 $\mu$ s filter and a 1K pull-up to +5V. Shared with F1.	8, 12, 13
Temperature Input	Thermostat (normally-closed) or Thermistor (Phillips KTY84-130 PTC or equivalent recommended) input for detecting over temperature conditions within the motor. If a thermostat is used, connect one side to 0V, and the other side to the Temperature Input (pin 11).	11
Travel Limit Inputs	Over-travel limit inputs. They consist of a 74HC14 input with a 10 $\mu$ s filter and a 1K pull-up to +5V.	9, 15
Encoder Power Outputs	Regulated +5VDC and regulated +9V VDC for powering the attached encoder.	7, 14
Signal and Power Common	Return path for feedback signals and power supplies (+5V and 9 V).	6

Table 5-14: Pin Assignments for Feedback Connector (F2) (Digital Interfaced MMC-SD Only)			
Pin Assignments F2 Feedback 15 Pin Connector 230V Single Phase (500W, 1kW, 2kW)			
Pin	Label	In/Out	Connector Pinout
1	A2	In	15-pin Female HD D-Sub  
2	A2/	In	
3	B2	In	
4	B2/	In	
5	I2	In	
6	Common	In/Out	
7	+9V	Out	
8	S3	In	
9	Travel Limit+	In	
10	I2/	In	
11	Temperature	In	
12	S1	In	
13	S2	In	
14	+5V	Out	
15	Travel Limit-	In	
Shell	Shield	In	

## 5.2.7 Drive I/O Connector (IO)

Signal Type	Notes	Pins
Analog Command Inputs (Analog Interfaced MMC-SD only)	Analog velocity or torque commands of 0 to +/- 10V. Separate scale and offset parameters are used relative to the command signal being velocity or torque	14, 15
Fast Inputs (Digital Interfaced MMC-SD only)	Used for latching encoder position.	8, 9, 11, 12
General Purpose Software Assignable Inputs	24VDC sourcing type. Default assignments: Pin 17 (GPIN1) = Drive Enable, Pin 18 (GPIN2) = Fault Reset	17, 18, 19, 20, 21, 22
Buffered F1 Encoder Output	RS485 drivers are used and the signal that is output depends on the encoder or resolver type used. See Specifications in Chapter 5 of this manual. These signals are generated after the feedback from the F1 connector is filtered and processed.	1, 2, 3, 4, 5, 6
General Purpose Software Assignable Outputs	24VDC sourcing type. Default assignment: Pin 26 (GPOUT4) = Drive Ready	23, 24, 25, 26
IO24V, IO24COM	24 VDC inputs for powering GPIN and GPOUT I/O.	10, 16

Table 5-16: Pin Assignment for Drive I/O Connector (IO)

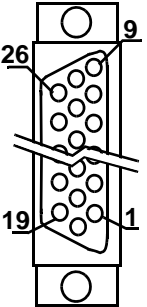
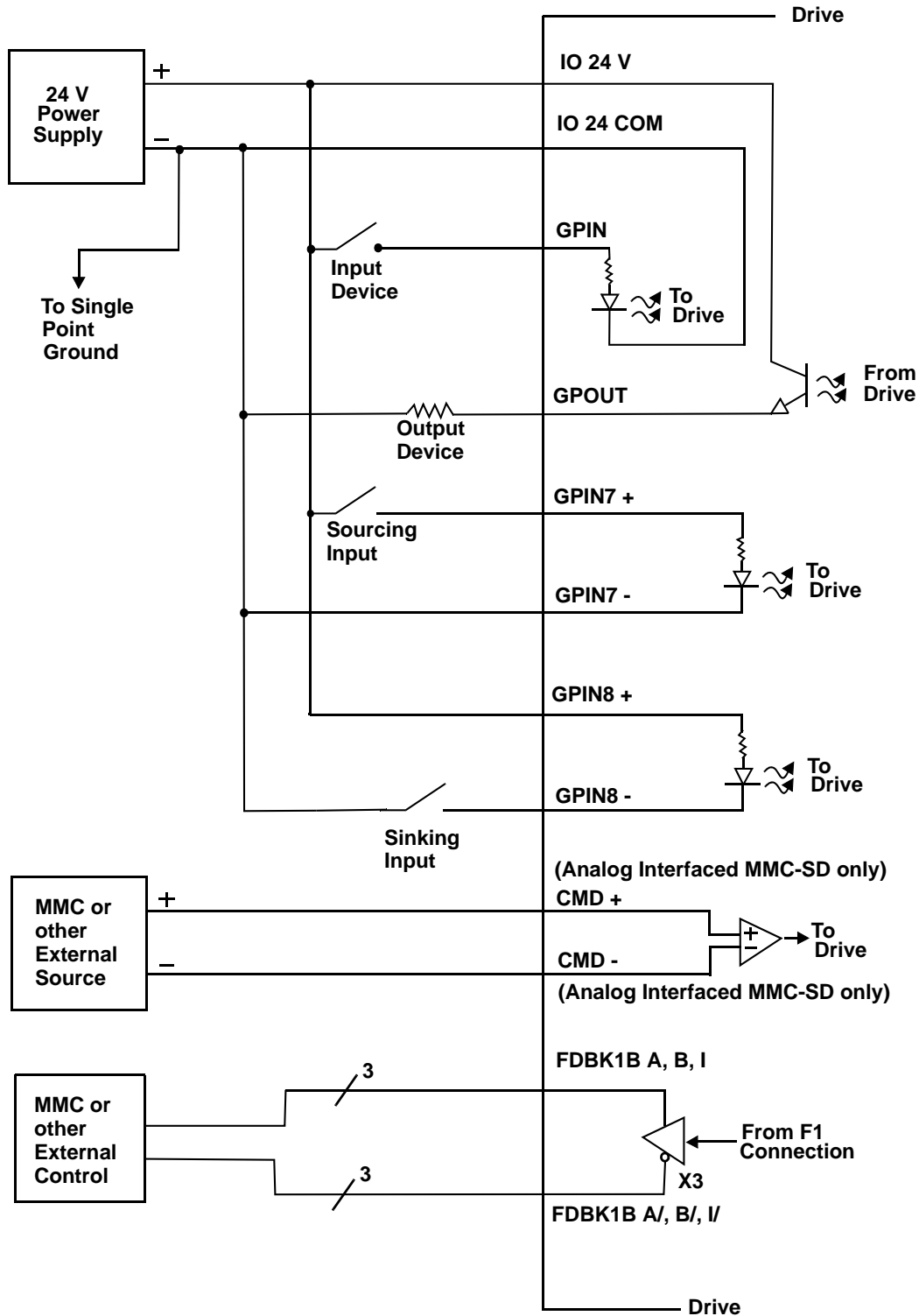
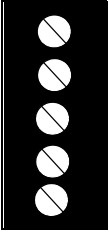

Pin	Wiring Label	PiCPro I/O Label	In/Out	Pin	Wiring Label	PiCPro I/O Label	In/Out	Connector Pinout
1	FDBK1B A		Out	14	CMD +		In	26-pin Female HD D-Sub  
2	FDBK1B A/		Out	15	CMD -		In	
3	FDBK1B B		Out	16	IO24COM		In	
4	FDBK1B B/		Out	17	GPIN1	Input1	In	
5	FDBK1B I		Out	18	GPIN2	Input2	In	
6	FDBK1B I/		Out	19	GPIN3	Input3	In	
7	Shield		Out	20	GPIN4	Input4	In	
8	GPIN7 +	Input7	In	21	GPIN5	Input5	In	
9	GPIN7 -		In	22	GPIN6	Input6	In	
10	IO24V		In	23	GPOUT1	Output1	Out	
11	GPIN8 +	Input8	In	24	GPOUT2	Output2	Out	
12	GPIN8 -		In	25	GPOUT3	Output3	Out	
13	Shield			26	GPOUT4	Output4	Out	

Figure 5-3: Wiring Diagram for Drive I/O Connector (IO)



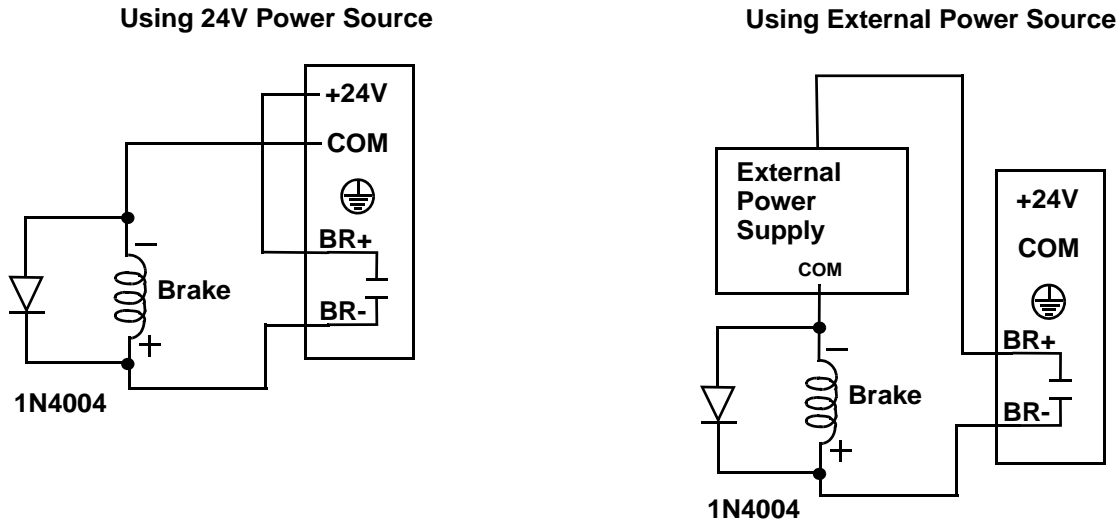
5.2.8 24 VDC IN/Brake Terminal Strip

Table 5-17: Pin Assignment for 24 VDC IN/Brake Terminal Strip					
Terminal Label	Signal Type	Signal Description	PiCPro I/O Label	In/Out	Connector Pinout
+24V	Logic Power	+24V user supplied power signal terminal.	N/A	In	5-pin Pluggable Screw Terminal 
COM	Common	+24V Common	N/A	In	
	Protective Ground	Must be connected to Protective Earth Ground (SPG)	N/A	In	
BR+	Brake Relay +	Refer to Figure 5-3 below.	Output5 /Relay	Out	
BR-	Brake Relay -			Out	

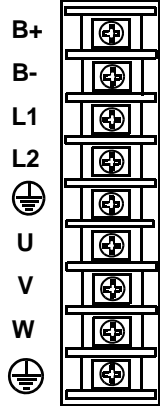
**NOTE**

Use of a diode (as shown) or an external RC type snubber is highly recommended for use with inductive loads, especially DC inductive loads.

**Figure 5-4: BR+ and BR- Wiring Examples**



5.2.9 Motor Terminal Strip

Table 5-18: Pin Assignment for Motor Terminal Strip				
Terminal Label	Signal Type	Signal Description	In/Out	Pin Sequence
B+	DC Bus	Power from drive to active shunt	Out	9-pin non-plugable Screw Terminal  
B-				
L1	AC Power	100-240VAC single phase power in to drive.	In	
L2				
⊕	Protective Ground	Must be connected to Protective Earth Ground (SPG).	In	
U	Motor Power	Power U-phase from the drive to the motor.	Out	
V		Power V-phase from the drive to the motor.	Out	
W		Power W-Phase from the drive to the motor.	Out	
⊕	Protective Ground	Connection for motor ground.	In	

### 5.3 Specifications - 230V MMC Smart Drive

#### 5.3.1 General Data for all 230V Models

<b>General Drive Data</b>	
Minimum wire size for input power wires	1.5mm <sup>2</sup> (16 AWG) 75° C copper.
Maximum tightening torque for power wire terminals	1.17 Nm (10.4 in-lbs.)
Commutation	Three Phase Sinusoidal
Current Regulator	Digital PI 125 µsec. update rate
Velocity Regulator	Digital PID - 250 µsec. update rate
<b>Environmental Data</b>	
Operating Temperature Range	7° C to 55° C (45° F to 131° F)
Storage Temperature Range	-30° C to 70° C (-22° F to 158° F)
Humidity	5% to 95% non-condensing
Altitude	1500 m (5000 ft) Derate 3% for each 300 m above 1500m
Vibration Limits (per IEC 68-2-6) Operating/Non-operating	10-57 Hz (constant amplitude.15 mm) 57 - 2000 Hz (acceleration 2 g)
Shock (per IEC 68-2-27) Non-operating	Four shocks per axis (15g/11 msec)
<b>F1 and F2 Feedback Inputs</b>	
Input receiver type	Maxim 3098 A quad B differential RS422 receiver
Encoder signals	Differential quadrature
Input threshold	±200 mV
Input termination	150Ω, provided internally
Maximum input voltage	5V peak to peak differential -10 to +13.2V common mode
Maximum input signal frequency	720 K Hz (2.88 M feedback counts per second)



<b>General Purpose Inputs</b>	
Configuration	<ul style="list-style-type: none"> <li>• 8 optically isolated 24V DC inputs</li> <li>• Active high</li> <li>• 6 are current sourcing only (current flow into input)</li> <li>• 2 are sink or source</li> </ul>
Guaranteed On	15 VDC
Guaranteed Off	5 VDC
Time delay on	1 ms max.
Time delay off	1 ms max.
Input voltage	Nominal 24 VDC, maximum 30 VDC
<b>General Purpose Outputs</b>	
Configuration	<ul style="list-style-type: none"> <li>• 4 optically isolated 24V DC outputs</li> <li>• Active high</li> <li>• Current sourcing only (current into load)</li> <li>• Short circuit and overload protected</li> </ul>
Maximum current	50mA per output
Voltage range	24VDC +15%-10%
Time delay on for resistive loads	50 $\mu$ sec. max
Time delay off for resistive loads	50 $\mu$ sec. max
Leakage current in off state	0.5 mA max
<b>Command Input (Analog Interfaced Digital MMC-SD only)</b>	
Command Input	Analog velocity or torque, 0 to $\pm$ 10V 14 bit effective resolution

<b>Digital Link In/Out Ports (Digital Interfaced MMC-SD only)</b>	
"In" port	Sends and receives high speed data to and from connected MMC-SD's "Out" port.
"Out" port	Sends and receives high speed data to and from connected MMC-SD's "In" port.
Cable Type	Shielded, Straight Pinned, CAT5 or better (CAT5e, CAT6, etc.)
Maximum Cable Length	98.4 ft (100 m)

<b>Drive I/O Connector Encoder Emulation Output</b>	
F1 Motor Feedback Type	Input Limit Encoder Emulation Output (A quad B Differential Output)
Incremental Encoder	720 KHz 2.88 M counts/sec. The motor encoder A/B/I inputs are electrically buffered and retransmitted via the Drive I/O connector.
High Resolution Encoder	100 KHz 400 K counts/sec. The encoder SIN/COS signals are electrically squared and retransmitted as A/B. The index mark "I" is synthesized by the drive control DSP. Absolute position information is not available via the Encoder Emulation Output.
Resolver	500 RPS 2.00 M counts/sec. The field-installable resolver interface module converts the motor resolver to 1024 lines/4096 counts per revolution of A/B encoder output. The module synthesizes the index mark "I" once per revolution of the resolver. Absolute position information is not available via the Encoder Emulation Output.
<b>Conformity</b>	
CE Marked	Conforms to Low Voltage Directive 73/23/EEC (amended by 93/68/EEC) and EMC Directive 89/336/EEC (amended by 92/31/EEC and 93/68/EEC). Conformance is in accordance with the following standards: EN 50178 and EN61800-3
UL and C/UL Listed	E233454

5.3.2 Physical and Electrical Data for 230V Drives

	Model		
	MMC-SD-0.5-230 (-D)	MMC-SD-1.0-230 (-D)	MMC-SD-2.0-230 (-D)
<b>Physical</b>			
<b>Weight</b>	4.9 lbs. (2.23 kg)	5.6 lbs. (2.55 kg)	5.7 lbs. (2.59 kg)
<b>Electrical Specifications</b>			
<b>AC Input Specifications</b>			
Nominal Input Power	1.0 kVA	2.0 kVA	4.0 kVA
Input Voltage	100-240 VAC (nominal), Single Phase, 88-265 VAC (absolute limits)		
Input Frequency	47 - 63 Hz		
Nominal Input Current	5A RMS	9A RMS	18A RMS
Maximum Inrush Current (0-Peak)	70A	70A	70A
Power Loss	22W	37W	70W
<b>AC Output Specifications</b>			
Continuous Output Current (0-Peak)	2.5A	5A	10A
<b>Continuous Output Power</b>			
Input = 115 VAC	250W	500W	1kW
Input = 230 VAC	500W	1kW	2kW
Peak Output Current (0-Peak)	7.5A	15A	30A
Output Frequency	0-266 Hz		
<b>DC Input Power Specifications (24VDC)</b>			
Input Voltage Range	24 VDC +15% -10%		
Typical Input Current	350 mA		650 mA
Typical Input Wattage	9 W		16 W
Inrush Current	1.5 A for 10 ms		

<b>Relay Contact for Motor Mechanical Brake</b>		
<b>Rating (resistive load)</b>		
Nominal switching capacity	24 VDC	
Maximum switching power	831 VA	
Maximum switching voltage	250 VAC / 100 VDC	
Maximum switching current	5 A (AC) / 2.5 A (DC)	
<b>Energy Absorbtion Specifications</b>		
DC Bus Capacitance (Internal)	1410 $\mu$ F	1880 $\mu$ F
Bus overvoltage threshold	420 VDC	
<b>Joules available for energy absorption</b>		
230V motor w/115V line input	94 joules	126 joules
230V motor w/230V line input	38 joules	51 joules

## 5.4 Dimensions for 230V MMC Smart Drive

This section contains dimensional information on the narrow width (-DN) Digital MMC-SD drive, the standard width (-D) Digital MMC-SD drive, and the Analog Interfaced drive (no letter suffix). Use this information to determine mounting hole locations on the drive panel.

When locating the drive on the panel, observe the clearance requirements found in [Table 3-1 on page 19](#). Mount the drive to the panel with #10 bolts and #10 star washers (to ensure proper ground connection).

Figure 5-5: 500 W Narrow Drive (-DN) - Front View

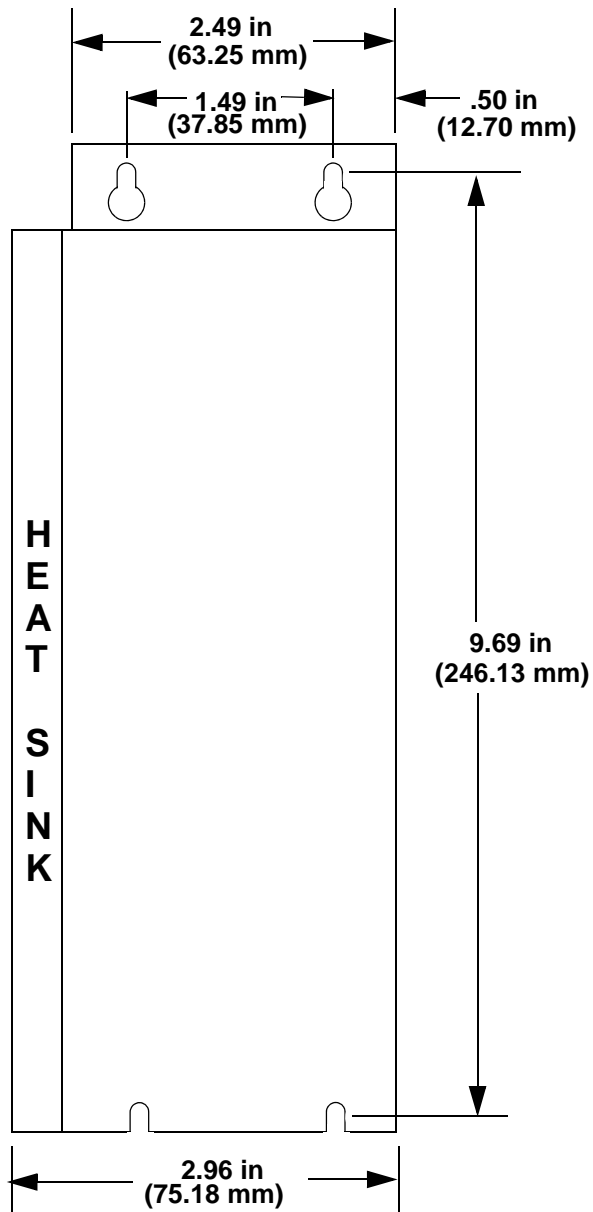


Figure 5-6: 500 W Standard Drive (non-DN) - Front

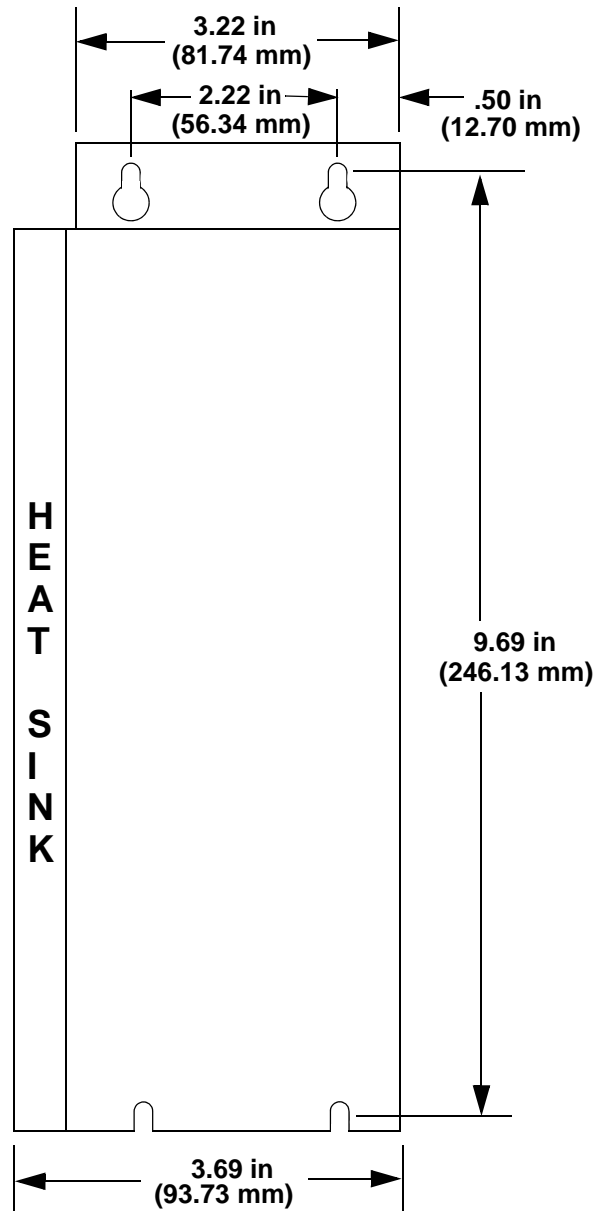


Figure 5-7: 1 kW & 2 kW Narrow Drive (-DN) - Front View

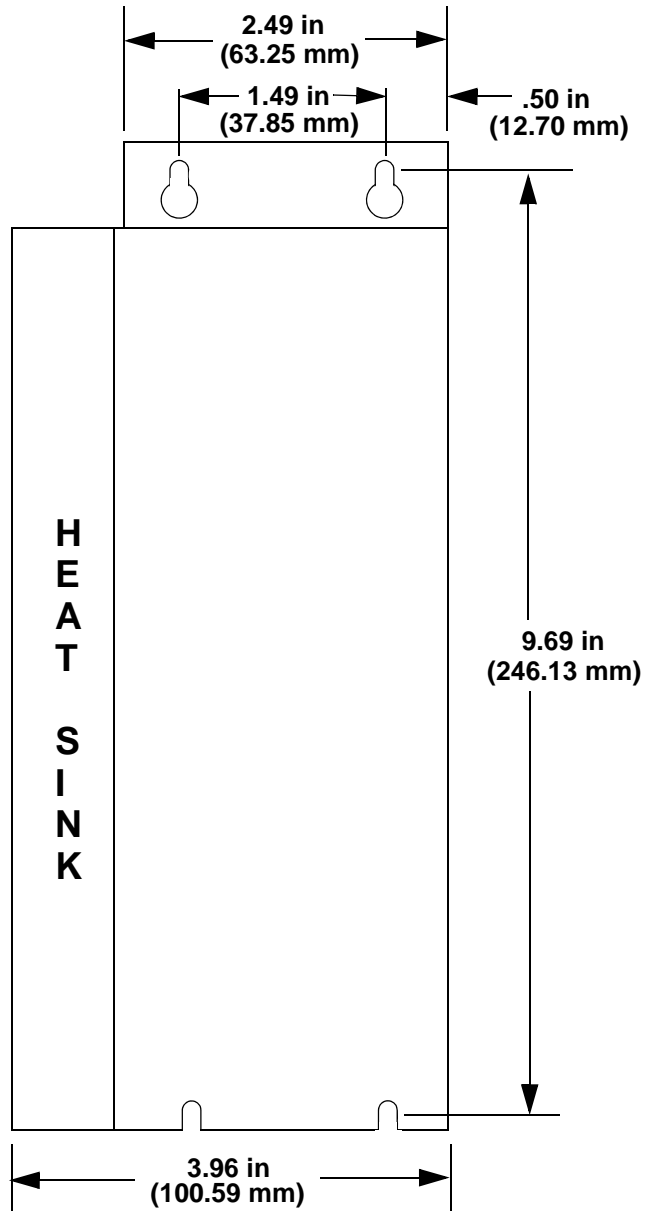


Figure 5-8: 1 kW &amp; 2 kW Standard Drive (non-DN) - Front View

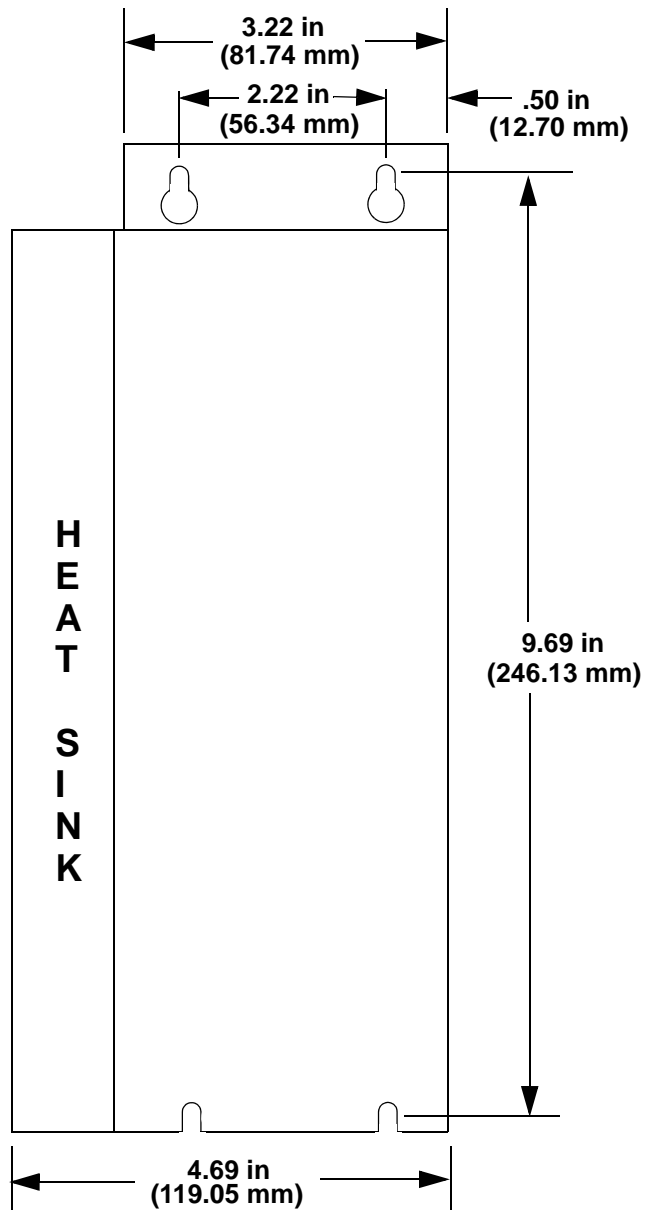
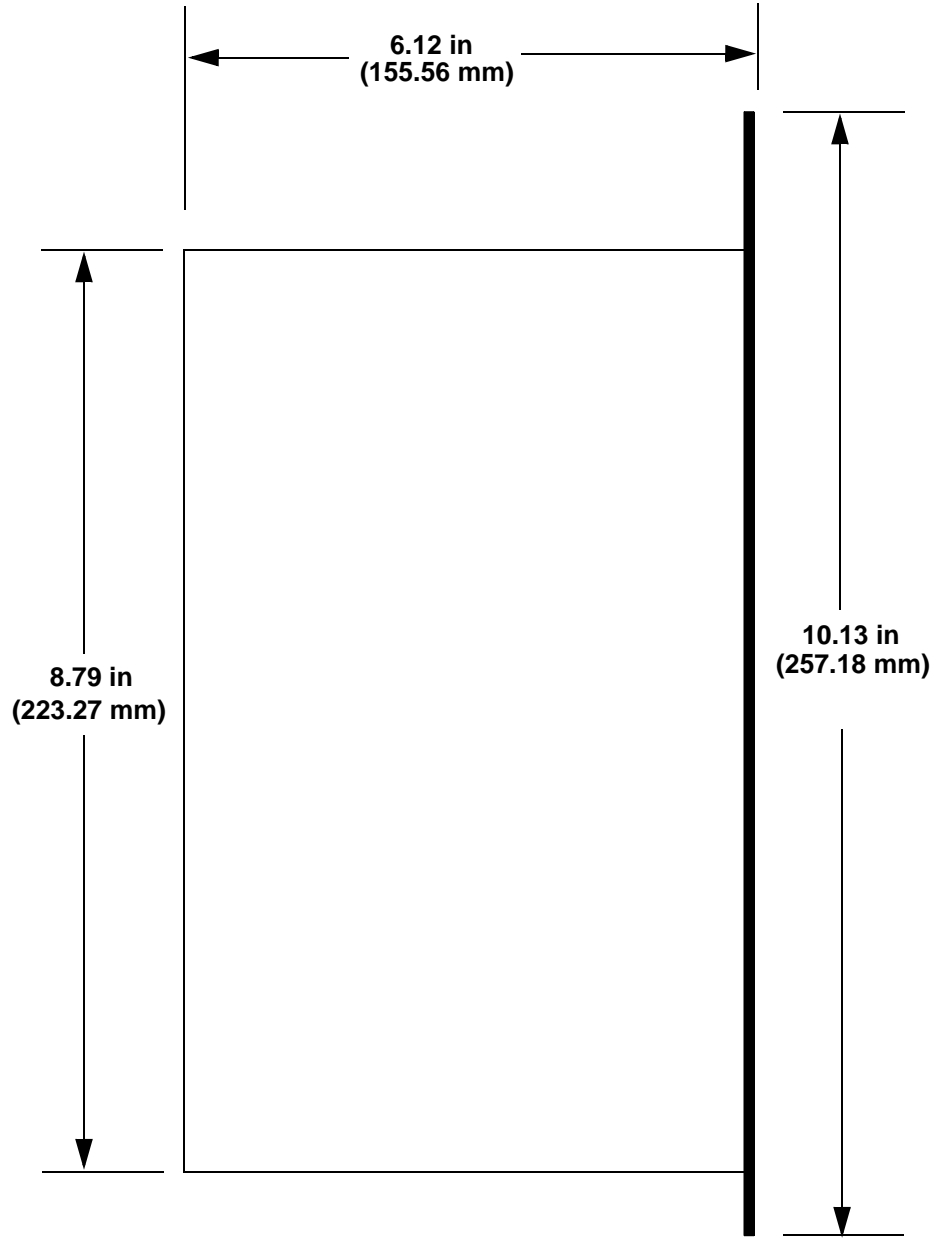




Figure 5-9: 230V Standard (non -DN) and Narrow (-DN) Drive - Side View



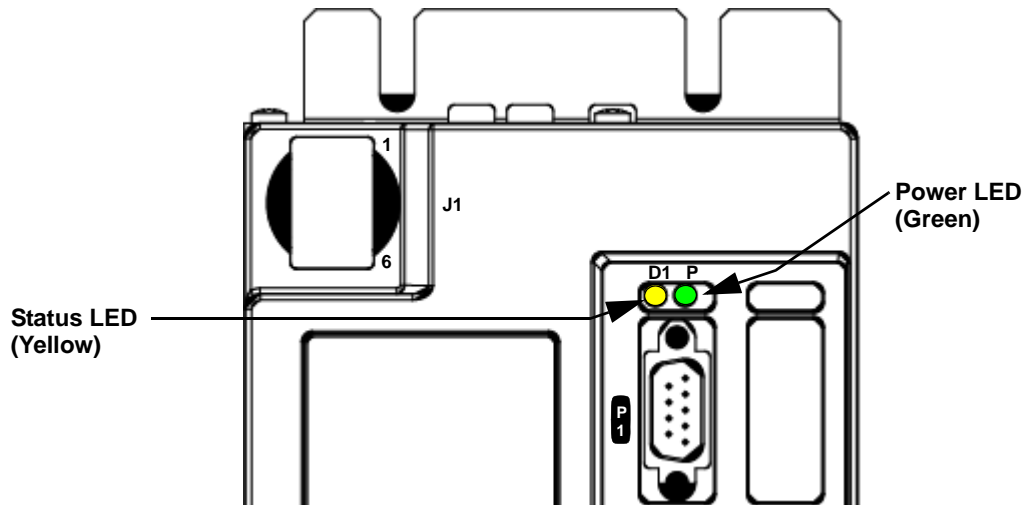


6 460V 3-Phase MMC Smart Drive

6.1 LEDs

Table 6-1: LEDs Description for 460V 3-Phase MMC Smart Drive		
LED	Color	Description
P	Green	Power LED. Indicates when illuminated that DC voltage is being supplied to the drive.
D1	Yellow	Status LED. Indicates drive status and fault information.

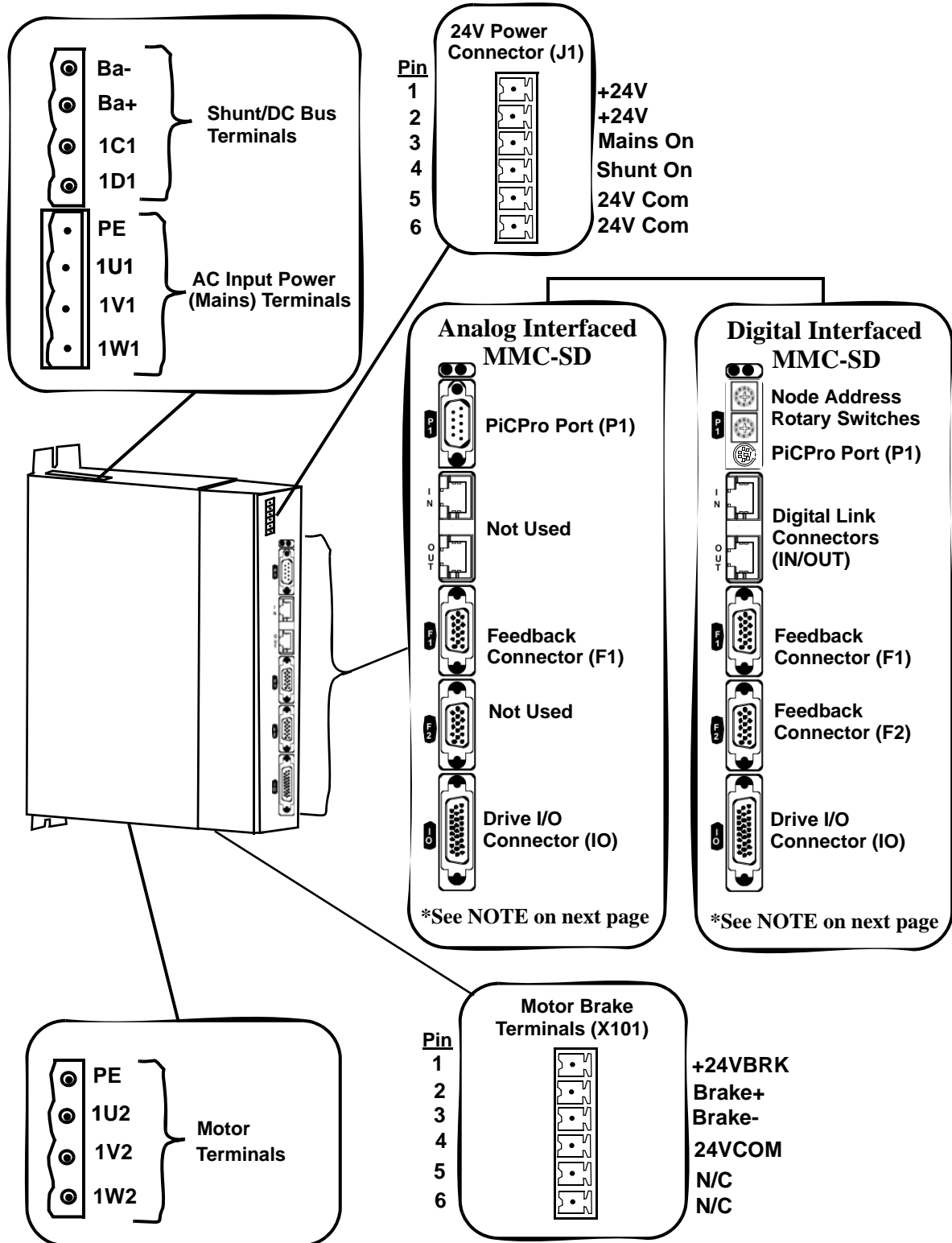
Figure 6-1: LEDs on the 460V Smart Drive



6.2 Connectors on the 460V Smart Drive

6.2.1 Size 1 460V Smart Drive Connectors

Figure 6-2: Connectors on the Size 1 460V Smart Drive

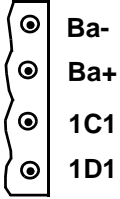


**NOTE**

The functionality and descriptions for the switches and connectors on the control section of the 460V MMC Smart Drives are the same as those on the 230V MMC Smart Drive. Refer to [section 5.2 on page 63](#) for more information.

**6.2.1.1 Shunt/DC Bus Terminals**

**Table 6-2: 460V Size 1 Shunt/DC Bus Terminals**

Signal Type	Signal Description	Terminal Label	In/Out	Terminal
Power	External Shunt Resistor. Used to dissipate energy returned to the drive by the motor.	Ba-	Out	
		Ba+		
DC Bus Power	Direct DC bus connection	1C1 (ZK+)	N/A	
		1D1 (ZK-)		

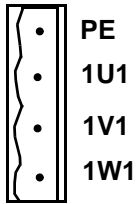
**NOTE**

The shunt resistor (if installed) across Ba+ and Ba- will be connected across the DC bus when the DC bus reaches the “shunt switch threshold” as shown in the specification table; or when the “Shunt On” input on the J1 connector is active.

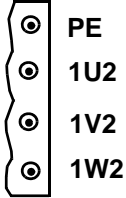
**NOTE**

If a 460V drive is connected to 220V to run a 220V motor, enable the “220V Shunt on 440V Drive” feature using PiCPro, connect GPOUT3 on the Drive I/O (IO) connector to the “Shunt On” input on the J1 connector, and install the appropriate shunt resistor across the Ba+ and Ba- terminals. The shunt resistor will be applied across the DC bus when the DC bus voltage rises above 415 volts, and will be removed when the DC bus voltage falls below 400 volts.

6.2.1.2 AC Power Terminal Strip

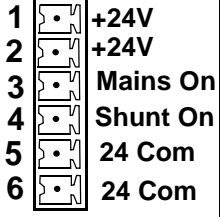
Table 6-3: 460V Size 1 AC Power Terminals				
Signal Type	Signal Description	Terminal Label	In/Out	Terminal
Protective Ground	Protective Earth Ground	PE	Out	
Power	3 phase input power AC source must be center grounded Y system.	1U1	In	
		1V1		
		1W1		

6.2.1.3 Motor Terminals

Table 6-4: 460V Size 1 Motor Terminals				
Signal Type	Signal Description	Terminal Label	In/Out	Terminal
Protective Ground	Protective Earth Ground	PE	Out	
Power	Drive output power to motor.	1U2	Out	
		1V2		
		1W2		

6.2.1.4 24V Power Connector (J1)

**Table 6-5: 460V Size 1 24V Power Connector (J1)**

Signal Type	Signal Description	Pin	Terminal Label	In/Out	Terminal
Power	24 VDC input power	1	+24V	In	Top  
		2	+24V		
24V Logic Output	Reserved for future use, do not use!	3	Mains On	Out	
24V Logic Input	When this input is active, the shunt resistor (if installed) between Ba+ and Ba- is connected across the DC bus.	4	Shunt On	In	
Power	24 VDC input common to the drive.	5	24V Com	In	
		6	24V Com		

**CAUTION**

A possible ignition hazard within the MMC 460V Smart Drives exists if excessive current is drawn from the 24 VDC powering the MMC Smart Drive. To prevent this possibility (due to improper wiring or 24 VDC supply failure), a fuse should be used in series with the 24 VDC to the MMC Smart Drive (4 A max). In addition, the 24 VDC shall be supplied by an isolating source such that the maximum open circuit voltage available to the MMC Smart Drive is not more than 30 VDC.

6.2.1.5 Motor Brake Terminals (X101)

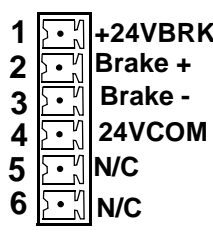
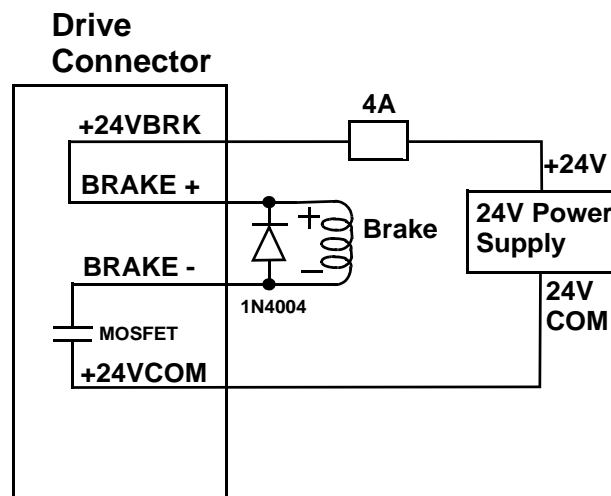
Table 6-6: 460V Size 1 Motor Brake Terminals (X101)					
Signal Type	Signal Description	Pin	Terminal Label	In/Out	Terminal
Power	24 VDC brake input power	1	+24VBRK	In	<div style="text-align: center;">Top</div> 
Brake control	Brake connections	2	Brake +	Out	
		3	Brake -	In	
Power	24 VDC common	4	24VCOM	Out	
Not Used.		5	N/C	Not Used	
		6			

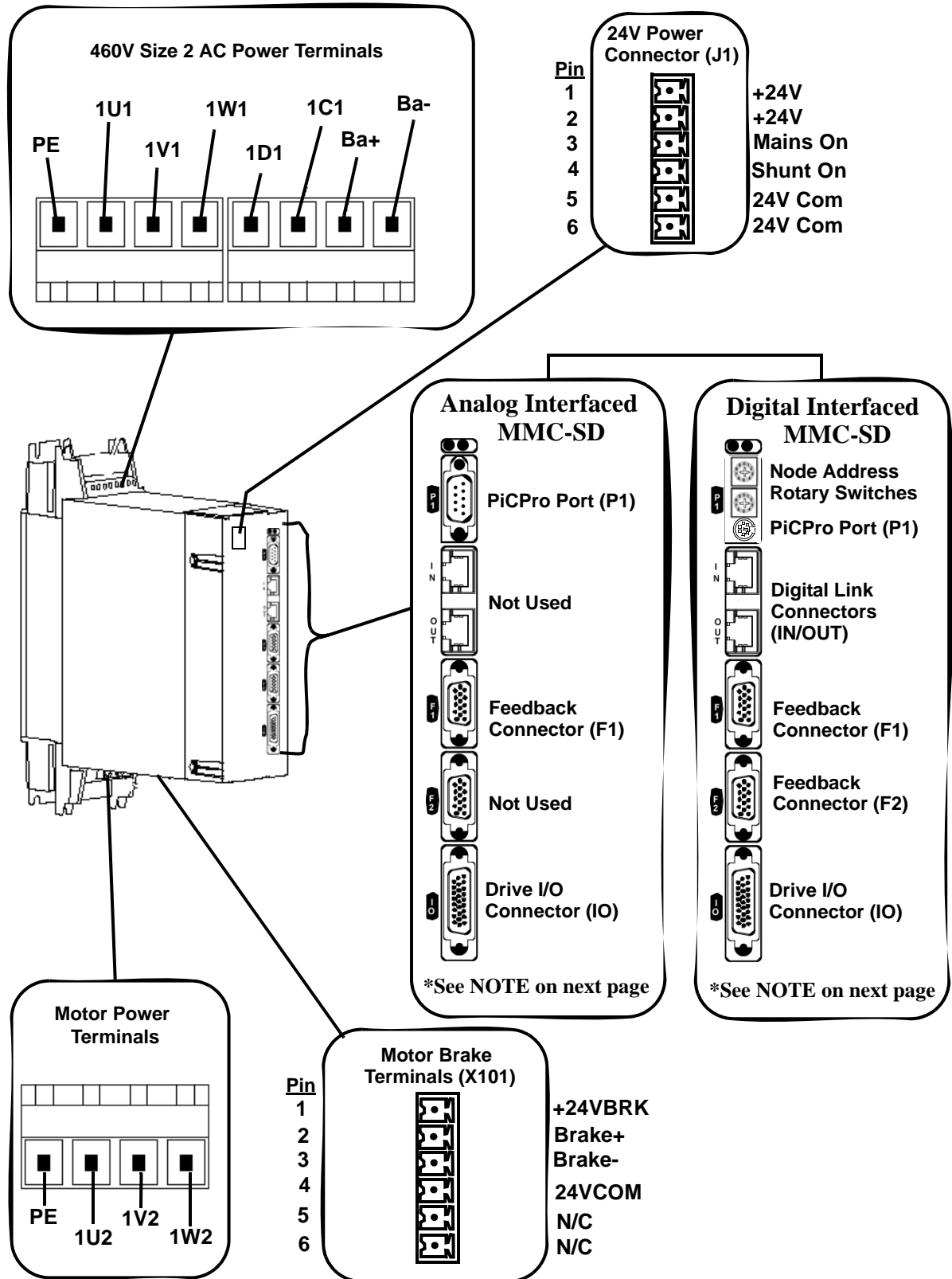
Figure 6-3: Wiring Example for X101 Connector





6.2.2 Size 2 460V Drive Smart Drive Connectors

Figure 6-4: Connectors on the Size 2 460V Drive

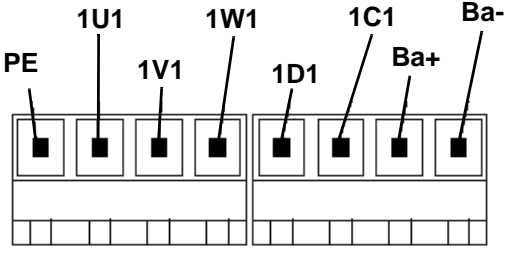


**NOTE**

The functionality and descriptions for the switches and connectors on the control section of the 460V MMC Smart Drives are the same as those on the 230V MMC Smart Drive. Refer to [section 5.2 on page 63](#) for more information.

**6.2.2.1 AC Power Terminals**

**Table 6-7: 460V Size 2 AC Power Terminals**



Signal Type	Signal Description	Terminal Label	In/Out
Ground	Protective Ground (Earth)	PE	Out
Power	Three phase AC input power in to drive	1U1	In
		1V1	
		1W1	
DC Bus Power	Direct DC bus connection	1D1 (ZK-)	Out
		1C1 (ZK+)	
Power	External Shunt Resistor used to dissipate energy returned to the drive from motor	Ba+	Out
		Ba-	

**NOTE**

The shunt resistor (if installed) across Ba+ and Ba- will be connected across the DC bus when the DC bus reaches the “shunt switch threshold” as shown in the specification table; or when the “Shunt On” input on the J1 connector is active.

NOTE
<p>If a 460V drive is connected to 220V to run a 220V motor, enable the “220V Shunt on 440V Drive” feature using PiCPro, connect GPOUT3 on the Drive I/O (IO) connector to the “Shunt On” input on the J1 connector, and install the appropriate shunt resistor across the Ba+ and Ba- terminals. The shunt resistor will be applied across the DC bus when the DC bus voltage rises above 415 volts, and will be removed when the DC bus voltage falls below 400 volts.</p>

**6.2.2.2 Motor Power Terminals**

Signal Type	Signal Description	Terminal Label	In/Out	Terminal
Ground	Protective Ground (Earth)	PE	Out	<p>The diagram shows a terminal block with four terminals. From left to right, they are labeled PE, 1U2, 1V2, and 1W2. Each label is connected to its respective terminal by a vertical line.</p>
Motor	Power U-phase from the drive to the motor	1U2	Out	
	Power V-phase from the drive to the motor	1V2	Out	
	Power W-phase from the drive to the motor	1W2	Out	

6.2.2.3 24V Power Connector (J1)

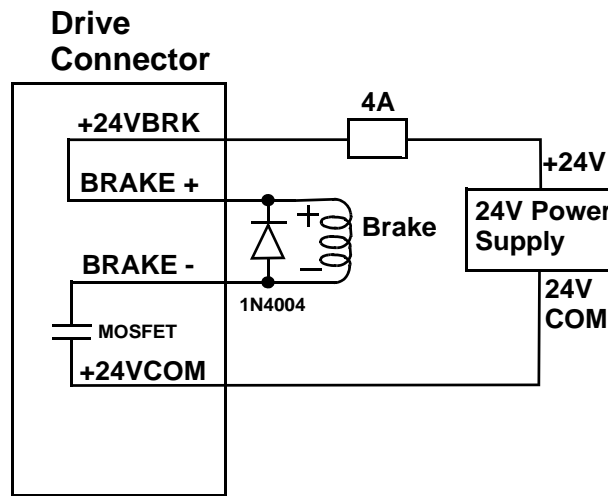
Table 6-9: 460V Size 2 24V Power Connector (J1)					
Signal Type	Signal Description	Pin	Terminal Label	In/Out	Terminal
Power	24 VDC input power	1	+24V	In	<p><b>Top</b></p>
		2	+24V		
24V Logic Output	Reserved for future use, do not use!	3	Mains On	Out	
24V Logic Input	When this input is active, the shunt resistor (if installed) between Ba+ and Ba- is connected across the DC bus.	4	Shunt On	In	
Power	24 VDC input common to the drive.	5	24V Com	In	
		6	24V Com		

CAUTION
<p>A possible ignition hazard within the MMC 460V Smart Drives exists if excessive current is drawn from the 24 VDC powering the MMC Smart Drive. To prevent this possibility (due to improper wiring or 24 VDC supply failure), a fuse should be used in series with the 24 VDC to the MMC Smart Drive. Specifically, a 4 A max. "UL248 Series" fuse should be used. In addition, the 24 VDC shall be supplied by an isolating source such that the maximum open circuit voltage available to the MMC Smart Drive is not more than 30 VDC.</p>

6.2.2.4 Motor Brake Terminals (X101)

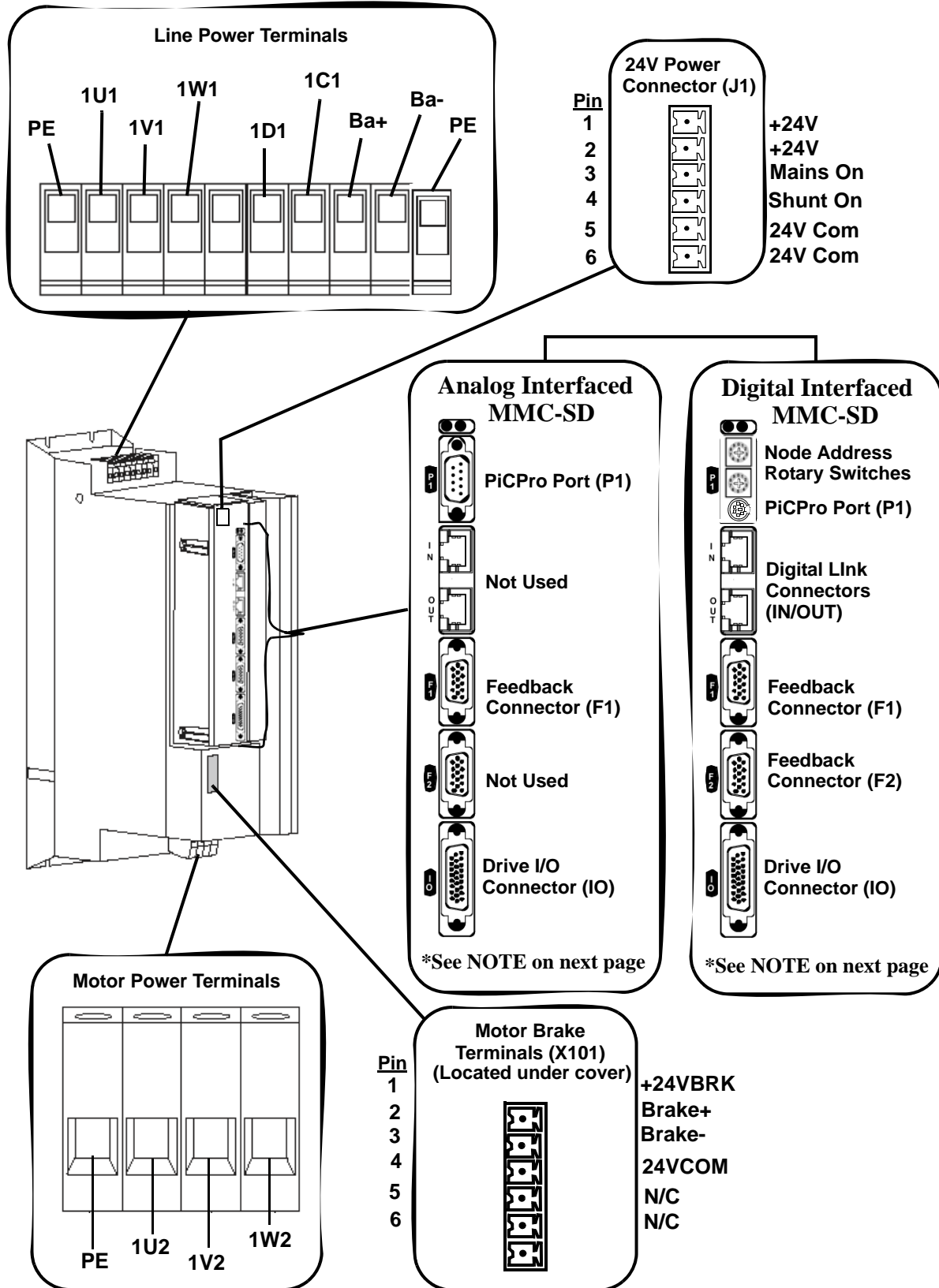
Table 6-10: 460V Size 2 Motor Brake Terminals (X101)					
Signal Type	Signal Description	Pin	Terminal Label	In/Out	Terminal
Power	24 VDC brake input power	1	+24VBRK	In	<p style="text-align: center;"><b>Top</b></p>
Brake control	Brake connections	2	Brake +	Out	
		3	Brake -	In	
Power	24 VDC common (supply and magnet)	4	24VCOM	Out	
Not Used.		5	N/C	Not Used	
		6			

Figure 6-5: Wiring Example for X101 Connector



6.2.3 Size 3 460V Drive Smart Drive Connectors

Figure 6-6: Connectors on the Size 3 460V Drive

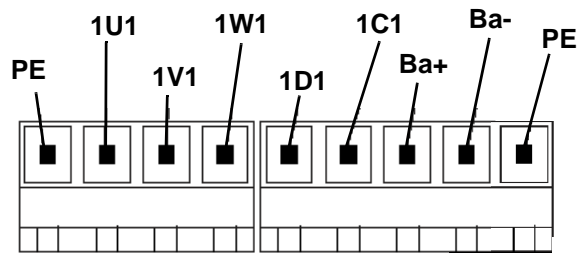


**NOTE**

The functionality and descriptions for the switches and connectors on the control section of the 460V MMC Smart Drives are the same as those on the 230V MMC Smart Drive. Refer to [section 5.2 on page 63](#) for more information.

**6.2.3.1 AC Power Terminals**

**Table 6-11: 460V Size 3 AC Power Terminals**



Signal Type	Signal Description	Terminal Label	In/Out
Ground	Protective Ground (Earth)	PE	Out
Power	Three phase AC input power in to drive	1U1	In
		1V1	
		1W1	
DC Bus Power	Direct DC bus connection	1D1 (ZK-)	Out
		1C1 (ZK+)	
	External Shunt Resistor used to dissipate energy returned to the drive from motor	Ba+	Out
		Ba-	

**NOTE**

The shunt resistor (if installed) across Ba+ and Ba- will be connected across the DC bus when the DC bus reaches the “shunt switch threshold” as shown in the specification table; or when the “Shunt On” input on the J1 connector is active.

NOTE
<p>If a 460V drive is connected to 220V to run a 220V motor, enable the “220V Shunt on 440V Drive” feature using PiCPro, connect GPOUT3 on the Drive I/O (IO) connector to the “Shunt On” input on the J1 connector, and install the appropriate shunt resistor across the Ba+ and Ba- terminals. The shunt resistor will be applied across the DC bus when the DC bus voltage rises above 415 volts, and will be removed when the DC bus voltage falls below 400 volts.</p>

6.2.3.2 Motor Power Terminals

Signal Type	Signal Description	Terminal Label	In/Out	Terminal
Ground	Protective Ground (Earth)	PE	Out	
Motor	Power U-phase from the drive to the motor	1U2	Out	
	Power V-phase from the drive to the motor	1V2	Out	
	Power W-phase from the drive to the motor	1W2	Out	



6.2.3.3 24V Power Connector (J1)

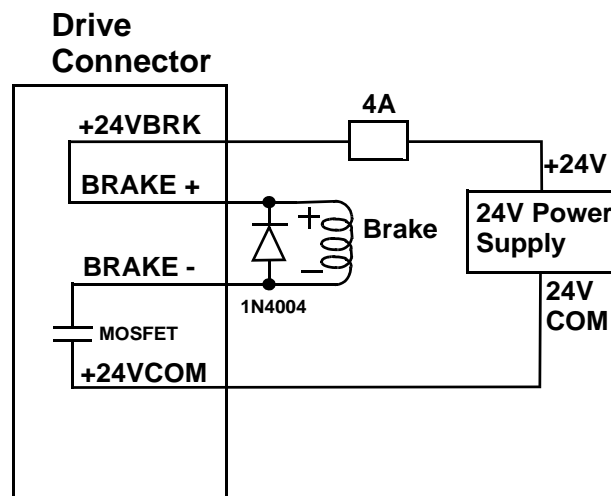
Table 6-13: 460V Size 3 24V Power Connector (J1)					
Signal Type	Signal Description	Pin	Terminal Label	In/Out	Terminal
Power	24 VDC input power	1	+24V	In	<p style="text-align: center;"><b>Top</b></p>
		2	+24V		
24V Logic Output	Reserved for future use, do not use!	3	Mains On	Out	
24V Logic Input	When this input is active, the shunt resistor (if installed) between Ba+ and Ba- is connected across the DC bus.	4	Shunt On	In	
Power	24 VDC input common to the drive.	5	24V Com	In	
		6	24V Com		

CAUTION
<p>A possible ignition hazard within the MMC 460V Smart Drives exists if excessive current is drawn from the 24 VDC powering the MMC Smart Drive. To prevent this possibility (due to improper wiring or 24 VDC supply failure), a fuse should be used in series with the 24 VDC to the MMC Smart Drive. Specifically, a 4 A max. "UL248 Series" fuse should be used. In addition, the 24 VDC shall be supplied by an isolating source such that the maximum open circuit voltage available to the MMC Smart Drive is not more than 30 VDC.</p>

6.2.3.4 Motor Brake Terminals (X101)

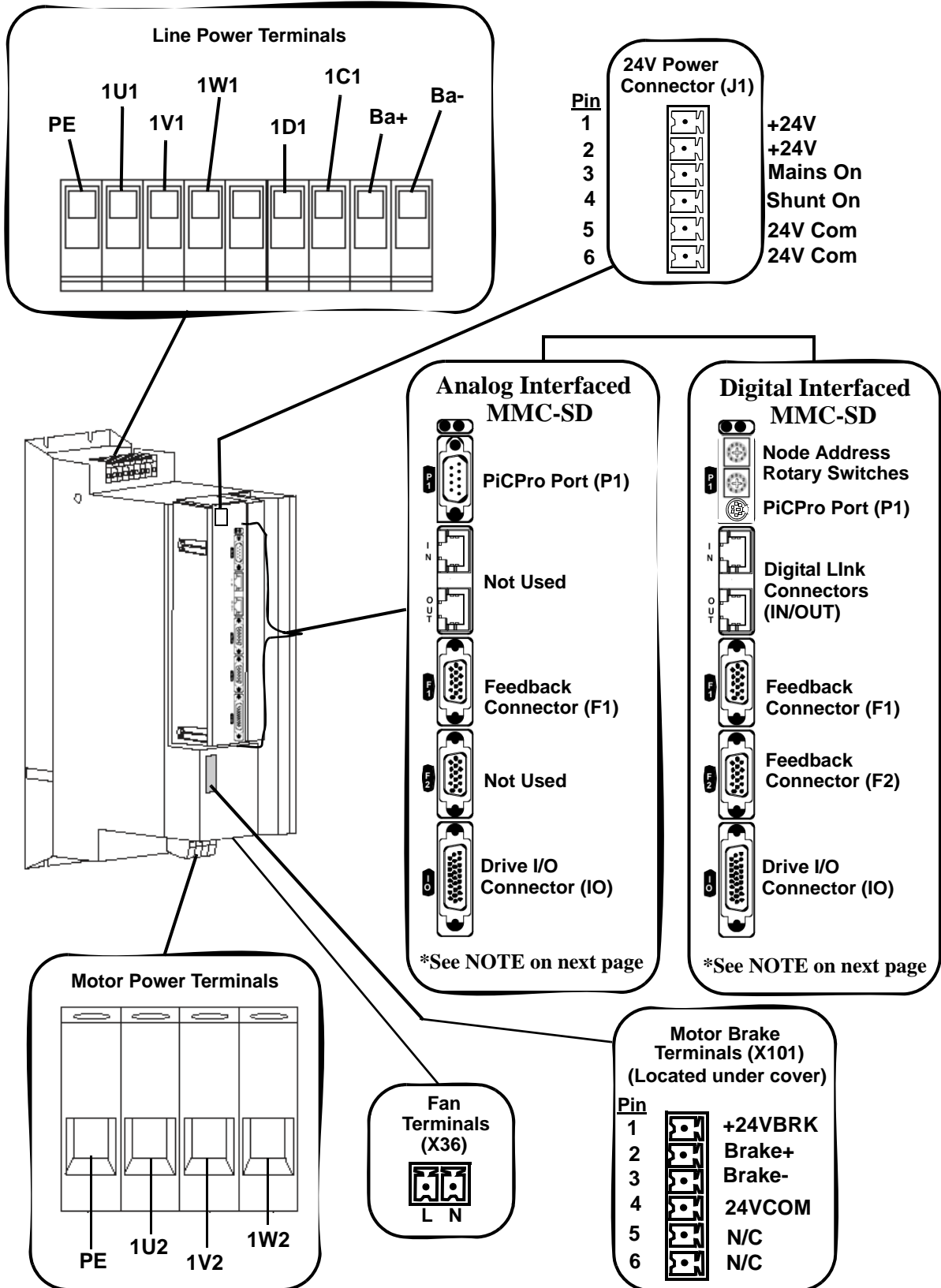
Table 6-14: 460V Size 3 Motor Brake Terminals (X101)					
Signal Type	Signal Description	Pin	Terminal Label	In/Out	Terminal
Power	24 VDC brake input power	1	+24VBRK	In	<p style="text-align: center;"><b>Top</b></p> <p>1 +24VBRK 2 Brake + 3 Brake - 4 24VCOM 5 N/C 6 N/C</p>
Brake control	Brake connections	2	Brake +	Out	
		3	Brake -	In	
Power	24 VDC common (supply and magnet)	4	24VCOM	Out	
Not Used.		5	N/C	Not Used	
		6			

Figure 6-7: Wiring Example for X101 Connector



6.2.4 Size 4 460V Drive Smart Drive Connectors

Figure 6-8: Connectors on the Size 4 460V Drive

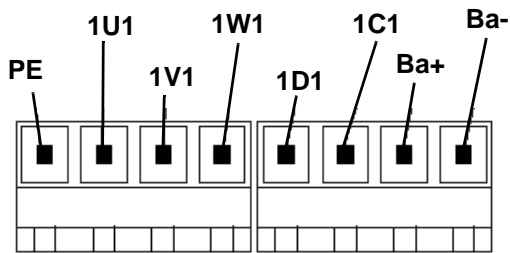


**NOTE**

The functionality and descriptions for the switches and connectors on the control section of the 460V MMC Smart Drives are the same as those on the 230V MMC Smart Drive. Refer to [section 5.2 on page 63](#) for more information.

**6.2.4.1 AC Power Terminals**

**Table 6-15: 460V Size 4 AC Power Terminals**



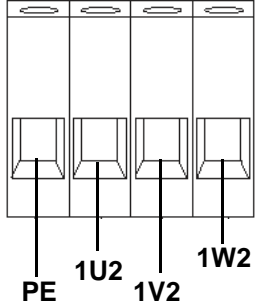
Signal Type	Signal Description	Terminal Label	In/Out
Ground	Protective Ground (Earth)	PE	Out
Power	Three phase AC input power in to drive	1U1	In
		1V1	
		1W1	
DC Bus Power	Direct DC bus connection	1D1 (ZK-)	Out
		1C1 (ZK+)	
	External Shunt Resistor used to dissipate energy returned to the drive from motor	Ba+	Out
		Ba-	

**NOTE**

The shunt resistor (if installed) across Ba+ and Ba- will be connected across the DC bus when the DC bus reaches the “shunt switch threshold” as shown in the specification table; or when the “Shunt On” input on the J1 connector is active.

NOTE
<p>If a 460V drive is connected to 220V to run a 220V motor, enable the “220V Shunt on 440V Drive” feature using PiCPro, connect GPOUT3 on the Drive I/O (IO) connector to the “Shunt On” input on the J1 connector, and install the appropriate shunt resistor across the Ba+ and Ba- terminals. The shunt resistor will be applied across the DC bus when the DC bus voltage rises above 415 volts, and will be removed when the DC bus voltage falls below 400 volts.</p>

6.2.4.2 Motor Power Terminals

Signal Type	Signal Description	Terminal Label	In/Out	Terminal
Ground	Protective Ground (Earth)	PE	Out	
Motor	Power U-phase from the drive to the motor	1U2	Out	
	Power V-phase from the drive to the motor	1V2	Out	
	Power W-phase from the drive to the motor	1W2	Out	

6.2.4.3 24V Power Connector (J1)

Table 6-17: 460V Size 4 24V Power Connector (J1)					
Signal Type	Signal Description	Pin	Terminal Label	In/Out	Terminal
Power	24 VDC input power	1	+24V	In	<p style="text-align: center;"><b>Top</b></p>
		2	+24V		
24V Logic Output	Reserved for future use, do not use!	3	Mains On	Out	
24V Logic Input	When this input is active, the shunt resistor (if installed) between Ba+ and Ba- is connected across the DC bus.	4	Shunt On	In	
Power	24 VDC input common to the drive.	5	24V Com	In	
		6	24V Com		

**CAUTION**

A possible ignition hazard within the MMC 460V Smart Drives exists if excessive current is drawn from the 24 VDC powering the MMC Smart Drive. To prevent this possibility (due to improper wiring or 24 VDC supply failure), a fuse should be used in series with the 24 VDC to the MMC Smart Drive. Specifically, a 4 A max. "UL248 Series" fuse should be used. In addition, the 24 VDC shall be supplied by an isolating source such that the maximum open circuit voltage available to the MMC Smart Drive is not more than 30 VDC.

6.2.4.4 Motor Brake Terminals (X101)

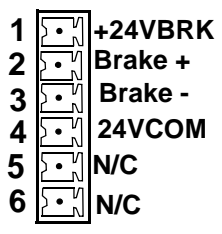
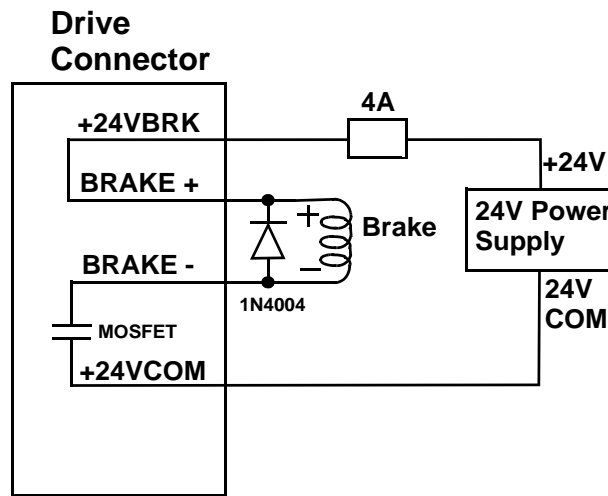
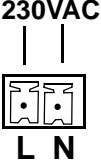
Table 6-18: 460V Size 4 Motor Brake Terminals (X101)					
Signal Type	Signal Description	Pin	Terminal Label	In/Out	Terminal
Power	24 VDC brake input power	1	+24VBRK	In	<div style="text-align: center;"> <b>Top</b>   </div>
Brake control	Brake connections	2	Brake +	Out	
		3	Brake -	In	
Power	24 VDC common (supply and magnet)	4	24VCOM	Out	
Not Used.		5	N/C	Not Used	
		6			

Figure 6-9: Wiring Example for X101 Connector

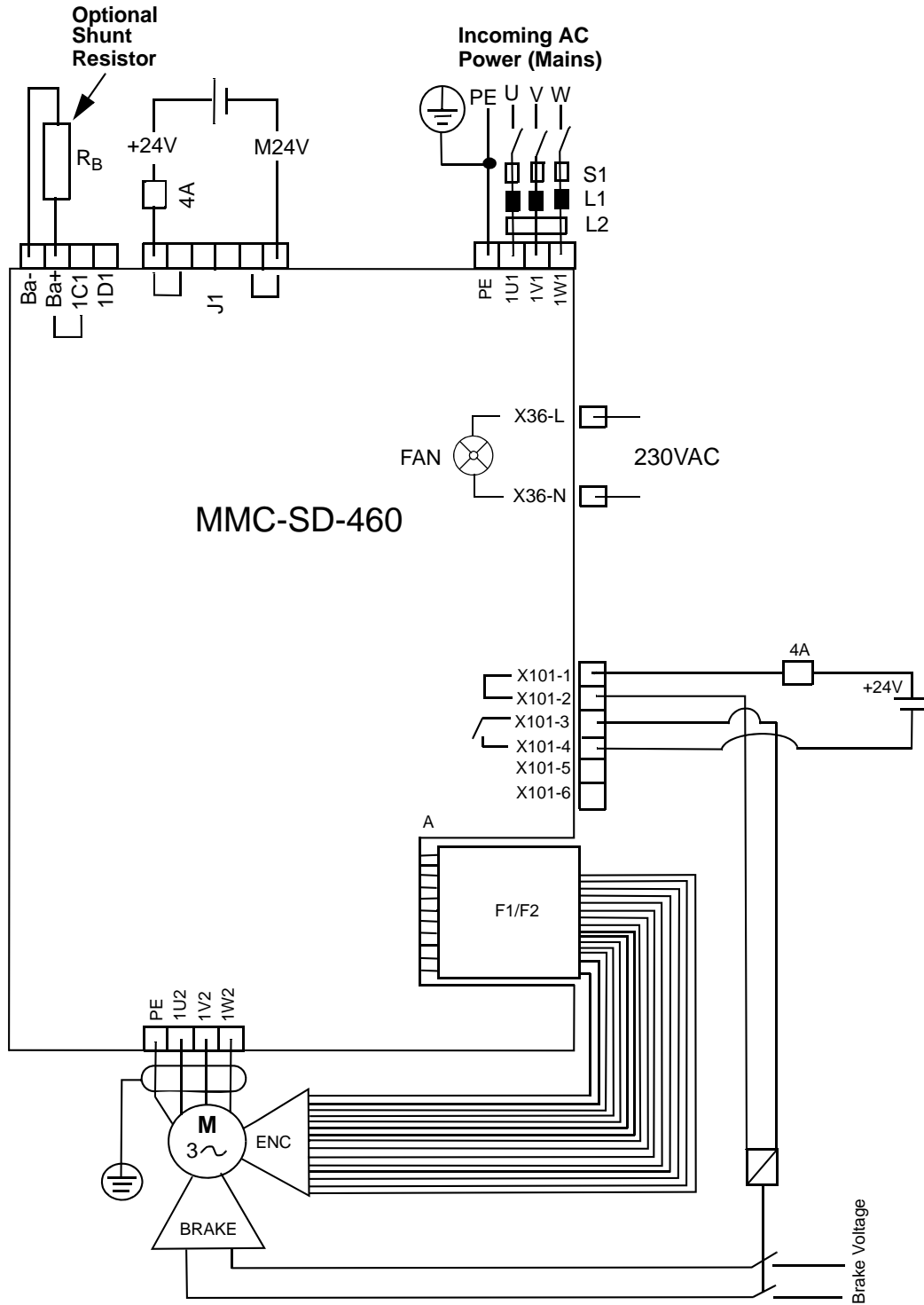


## 6.2.4.5 Fan Terminals (X36)

Table 6-19: 460V Size 4 Fan Terminals (X36)					
Signal Type	Signal Description	Pin	Terminal Label	In/Out	Terminal
Power	230VAC Line for powering the fan	1	L	In	 <p>230VAC</p> <p>L N</p>
Power	230VAC Neutral for powering the fan	2	N	In	



6.3 Typical 460V Drive Connection Layout



## 6.4 Specifications - 460V MMC Smart Drive)

### 6.4.1 Common Data for Size 1, 2, 3, 4 (All Models)

<b>General Drive Data</b>	
Minimum wire size for input power wires	1.5mm <sup>2</sup> (16 AWG) 75° C copper
Maximum tightening torque for power wire terminals	1.25Nm (11 in-lbs.)
Commutation	3 Phase Sinusoidal, Space Vector Modulated (SVM)
Current Regulator	Digital PI 125 µsec update rate
Velocity Regulator	Digital PID - 250 µsec update rate
<b>General Operating Data</b>	
Operating Temperature Range (MMC-SD-1.3, -2.4, -4.0, -6.0, -8.0, -12.0, -16.0, -24.0)	7° C to 50° C (45° F to 122° F)
Operating Temperature Range (MMC-SD-30.0, -42.0, -51.0, -65.0)	7° C to 55° C (45° F to 131° F). Derate 3% per° C above 40° C.
Storage Temperature Range	-30° C to 70° C (-22° F to 158° F)
Humidity	5% to 95% non-condensing
Altitude	1500m (5000ft) Derate 3% for each 300 m above 1500m
Vibration Limits (per IEC 68-2-6) Operating/Non-operating	10-57Hz (constant amplitude .15mm) 57 - 2000Hz (acceleration 2g)
Shock (per IEC 68-2-27) Non-operating	15g/11msec per axis
<b>F1 and F2 Feedback Inputs</b>	
Input receiver type	Maxim 3098 A quad B differential RS422 receiver
Encoder signals	Differential quadrature
Input threshold	±200mV
Input termination	150Ω, provided internal
Maximum input voltage	5Vpp differential -10 to +13.2V common mode
Maximum input signal frequency	720KHz (2.88 M feedback unit count rate)

<b>General Purpose Inputs</b>	
Configuration	<ul style="list-style-type: none"> <li>• 8 optically isolated 24V DC inputs</li> <li>• Active high</li> <li>• 6 are current sourcing only (current flow into input)</li> <li>• 2 are sink or source</li> </ul>
Guaranteed On	15VDC
Guaranteed Off	5VDC
Time delay on	1ms max.
Time delay off	1ms max.
Input voltage	Nominal 24VDC, maximum 30VDC
<b>General Purpose Outputs</b>	
Configuration	<ul style="list-style-type: none"> <li>• 4 optically isolated 24VDC outputs</li> <li>• Active high</li> <li>• Current sourcing only (current into load)</li> <li>• Short circuit and overload protected</li> </ul>
Maximum current	50mA per output
Voltage range	24VDC +15%-10%
Time delay on for resistive loads	50µsec. max
Time delay off for resistive loads	50µsec. max
Leakage current in off state	0.5mA max
<b>Command Input/Output</b>	
Command Input	Analog velocity or torque, 0 to ± 10V 14 bit effective resolution
<b>Digital Link In/Out Ports (Digital Interfaced MMC-SD only)</b>	
“In” port	Sends and receives high speed data to and from connected MMC-SD’s “Out” port.
“Out” port	Sends and receives high speed data to and from connected MMC-SD’s “In” port.
Cable Type	Shielded, Straight Pinned, CAT5 or better (CAT5e, CAT6, etc.)
Maximum Cable Length	82.5 ft (25 m)

<b>Drive I/O Connector Encoder Emulation Output</b>		
<b>F1 Motor Feedback Type</b>	<b>Input Limit</b>	<b>Encoder Emulation Output (A quad B Differential Output)</b>
Incremental Encoder	720KHz 2.88 M counts/sec.	The motor encoder A/B/I inputs are electrically buffered and retransmitted via the Drive I/O connector.
High Resolution Encoder	100KHz 400K counts/sec.	The encoder SIN/COS signals are electrically squared and retransmitted as A/B. The index mark "I" is synthesized by the drive control DSP. Absolute position information is not available via the Encoder Emulation Output.
Resolver	500RPS 2.00M counts/sec.	The field-installable resolver interface module converts the motor resolver to 1024 lines/4096 counts per revolution of A/B encoder output. The module synthesizes the index mark "I" once per revolution of the resolver. Absolute position information is not available via the Encoder Emulation Output.
<b>Conformity</b>		
CE Marked	Conforms to Low Voltage Directive 73/23/EEC (amended by 93/68/EEC) and EMC Directive 89/336/EEC (amended by 92/31/EEC and 93/68/EEC). Conformance is in accordance with the following standards: EN 50178 and EN61800-3	
UL and C/UL Listed	E233454	

## 6.4.2 Physical/Electrical Data for 460V Size 1 Smart Drives

	Model	
	MMC-SD-1.3-460 (-D)	MMC-SD-2.4-460 (-D)
<b>Physical</b>		
<b>Weight</b>	10 lbs.	
<b>Electrical Specifications</b>		
<b>AC Input Specifications</b>		
Nominal Input Power	1.94kVA	3.33kVA
Input Voltage	207-460 VAC (nominal), Three Phase, 187-528 VAC	
Input Frequency	47-63Hz	
Nominal Input	2.44A RMS	4.18A RMS
<b>NOTE:</b> Nominal Input Current is specified for nominal input voltage of 460 VAC.		
Maximum Inrush	4.56A RMS	7.81A RMS
Power Loss	34W	60W
<b>AC Output Specifications</b>		
Continuous Output	3.0A	5.5A
<b>Continuous Output Power</b>		
Input = 230 VAC	.65kW	1.2kW
Input = 460 VAC	1.3kW	2.4kW
Peak Output Current	6.0A	11.0A
Output Frequency	0-450Hz	
<b>DC Input Power Specifications (24VDC)</b>		
Input Voltage Range	24VDC +15% -10%	
Typical Input Current	700mA	
Typical Input Wattage	17W	
Inrush Current	4A for 10ms	

<b>Internal Holding Brake Driver</b>		
Maximum Current	0.5A	
<b>Energy Absorption Specifications</b>		
DC Bus Capacitance (Internal)	110 $\mu$ F	240 $\mu$ F
Shunt Switch Threshold	780VDC	
<b>Joules available for energy absorption</b>		
230V motor w/ 230V line input	3 joules	7 joules
460V motor w/ 230V line input	28 joules	60 joules
460V motor w/ 460V line input	10 joules	22 joules
<b>External Shunt</b>		
Maximum shunt resistor current	5.9A (AC)	
Minimum shunt resistor	130 $\Omega$	
Maximum shunt resistor power at minimum shunt resistor	4.5kW	5kW

### 6.4.3 Physical/Electrical Data for 460V Size 2 Smart Drives

	Model		
	MMC-SD-4.0-460 (-D)	MMC-SD-6.0-460 (-D)	MMC-SD-8.0-460 (-D)
<b>Physical</b>			
<b>Weight</b>	16 lbs.		
<b>Electrical Specifications</b>			
<b>AC Input Specifications</b>			
Nominal Input Power	5.6kVA	8.6kVA	11.8kVA
Input Voltage	207-460 VAC (nominal), Three Phase, 187-528 VAC (absolute limits)		
Input Frequency	47-63Hz		
Nominal Input Current	7A RMS	10.8A RMS	14.8A RMS
<b>NOTE:</b> Nominal Input Current is specified for nominal input voltage of 460 VAC. Approximate Current for input voltages between 400 and 480 VAC = (listed current) x 460/input voltage			
Maximum Inrush Current	13.2A RMS	20.2A RMS	27.7A RMS
Power Loss	102W	150W	204W
<b>AC Output Specifications</b>			
Continuous Output Current (0-Peak)	9.0A	13.5A	18.0A
<b>Continuous Output Power</b>			
Input = 230 VAC	2.0kW	3.0kW	4.0kW
Input = 460 VAC	4.0kW	6.0kW	8.0kW
Peak Output Current (0-peak)	18.0A	27.0A	36.0A
Output Frequency	0Hz to 450Hz		
<b>Internal Holding Brake Driver</b>			
Maximum Current	0.5A		

<b>DC Input Power Specifications (24VDC)</b>			
Input Voltage Range	24VDC +15% -10%		
Typical Input Current	1050mA		
Typical Input Wattage	25W		
Inrush Current	4A for 10ms		
<b>Energy Absorbion Specifications</b>			
DC Bus Capacitance (Internal)	470 $\mu$ F	705 $\mu$ F	
Shunt Switch Threshold	780VDC		
<b>Joules available for energy absorption</b>			
230V motor w/230V line input	13 joules	19 joules	
460V motor w/230V line input	188 joules	177 joules	
460V motor w/460V line input	44 joules	66 joules	
<b>External Shunt</b>			
Maximum shunt resistor current	9A (AC)	9A (AC)	9A (AC)
Minimum shunt resistor	86 $\Omega$	60 $\Omega$	44 $\Omega$
Maximum shunt resistor power at minimum shunt resistor	7kW	10kW	14kW



## 6.4.4 Physical/Electrical Data for 460V Size 3 Smart Drives

	Model			
	MMC-SD-12.0-460 (-D)	MMC-SD-16.0-460 (-D)	MMC-SD-24.0-460 (-D)	MMC-SD-30.0-460-D
<b>Physical</b>				
<b>Weight</b>	35 lbs.			
<b>Electrical Specifications</b>				
<b>AC Input Specifications</b>				
Nominal Input Power	13.3kVA	16.8kVA	26.3 kVA	36.7 kVA
Input Voltage	207-460VAC (nominal), Three Phase, 187-528VAC (absolute limits)			
Input Frequency	47-63Hz			
Nominal Input Current	16.7A RMS	21.1A RMS	33.1A RMS	44.0A RMS
<b>NOTE:</b> Nominal Input Current is specified for nominal input voltage of 460 VAC. Approximate Current for input voltages between 400 and 480 VAC = (listed current) x 460/input voltage				
Maximum Inrush Current	32.2A RMS	39.2A RMS	61.8A RMS	tbdA RMS
Power Loss	300W	390W	600W	840W
<b>AC Output Specifications</b>				
Continuous Output Current (0-Peak)	27.5A	36.5A	55.0A	69.3A
<b>Continuous Output Power</b>				
Input = 230 VAC	6.0kW	8.0kW	12.0kW	15.0kW
Input = 460 VAC	12.0kW	16.0kW	24.0kW	30.0kW
Peak Output Current (0-peak)	55.0A	73.0A	110.0A	110.0A
Output Frequency	0Hz to 450Hz			
<b>Internal Holding Brake Driver</b>				
Maximum Current	0.5A		1.0A	

<b>DC Input Power Specifications (24VDC)</b>				
Input Voltage Range	24VDC +15% -10%			
Typical Input Current	1050mA			
Typical Input Wattage	25W			
Inrush Current	4A for 10ms			
<b>Energy Absorbtion Specifications</b>				
DC Bus Capacitance (Internal)	820 $\mu$ F	1230 $\mu$ F	1640 $\mu$ F	2000 $\mu$ F
Shunt Switch Threshold	780VDC			
<b>Joules available for energy absorption</b>				
230V motor w/ 230V line input	22 joules	33 joules	45 joules	553 joules
460V motor w/ 230V line input	206 joules	309 joules	412 joules	502 joules
460V motor w/ 460V line input	76 joules	114 joules	152 joules	185 joules
<b>External Shunt</b>				
Maximum shunt resistor current	36A (AC)		50A (AC)	
Minimum shunt resistor	22 $\Omega$		16 $\Omega$	
Maximum shunt resistor power at minimum shunt resistor	29kW		40kW	

6.4.5 Physical/Electrical Data for 460V Size 4 Smart Drives

	Model		
	MMC-SD-42.0-460-D	MMC-SD-51.0-460-D	MMC-SD-65.0-460-D
<b>Physical</b>			
<b>Weight</b>	59 lbs.		
<b>Electrical Specifications</b>			
<b>AC Input Specifications</b>			
Nominal Input Power	48.5kVA	58.2kVA	72.1kVA
Input Voltage	207-460VAC (nominal), Three Phase, 187-528VAC (absolute limits)		
Input Frequency	47-63Hz		
Nominal Input Current	58A RMS	72A RMS	95A RMS
<b>NOTE:</b> Nominal Input Current is specified for nominal input voltage of 460 VAC. Approximate Current for input voltages between 400 and 480 VAC = (listed current) x 460/input voltage			
Maximum Inrush Current	tbdA RMS	tbdA RMS	tbdA RMS
Power Loss	1080W	1350W	1740W
<b>AC Output Specifications</b>			
Continuous Output Current (0-Peak)	93.3A	117.4A	152.7A
<b>Continuous Output Power</b>			
Input = 230 VAC	21.0kW	25.1kW	32.5kW
Input = 460 VAC	42.0kW	51.0kW	65.0kW
Peak Output Current (0-peak)	147A	189A	209A
Output Frequency	0Hz to 450Hz		
<b>Internal Holding Brake Driver</b>			
Maximum Current	4.0A		

<b>DC Input Power Specifications (24VDC)</b>			
Input Voltage Range	24VDC +15% -10%		
Typical Input Current	3.2A		
Typical Input Wattage	77W		
Inrush Current	tbdA for tbdms		
<b>Energy Absorbion Specifications</b>			
DC Bus Capacitance (Internal)	1880 $\mu$ F	2350 $\mu$ F	3055 $\mu$ F
Shunt Switch Threshold	780VDC		
<b>Joules available for energy absorption</b>			
230V motor w/ 230V line input	50.4joules	63.1joules	82joules
460V motor w/ 230V line input	472joules	591joules	768joules
460V motor w/ 460V line input	173joules	218joules	284joules
<b>External Shunt</b>			
Maximum shunt resistor current	67A (AC)	100A (AC)	100A (AC)
Minimum shunt resistor	12 $\Omega$	8 $\Omega$	8W
Maximum shunt resistor power at minimum shunt resistor	53kW	80	80kW
<b>Fan (X36 Connector)</b>			
Input Voltage	230VAC (nominal), 207VAC to 253VAC, 50/60HZ		
Input Current	1A Max		
Power Loss	87W		

6.5 Dimensions for the 460V Smart Drives

Figure 6-10: Size 1 460V Smart Drive - Front View

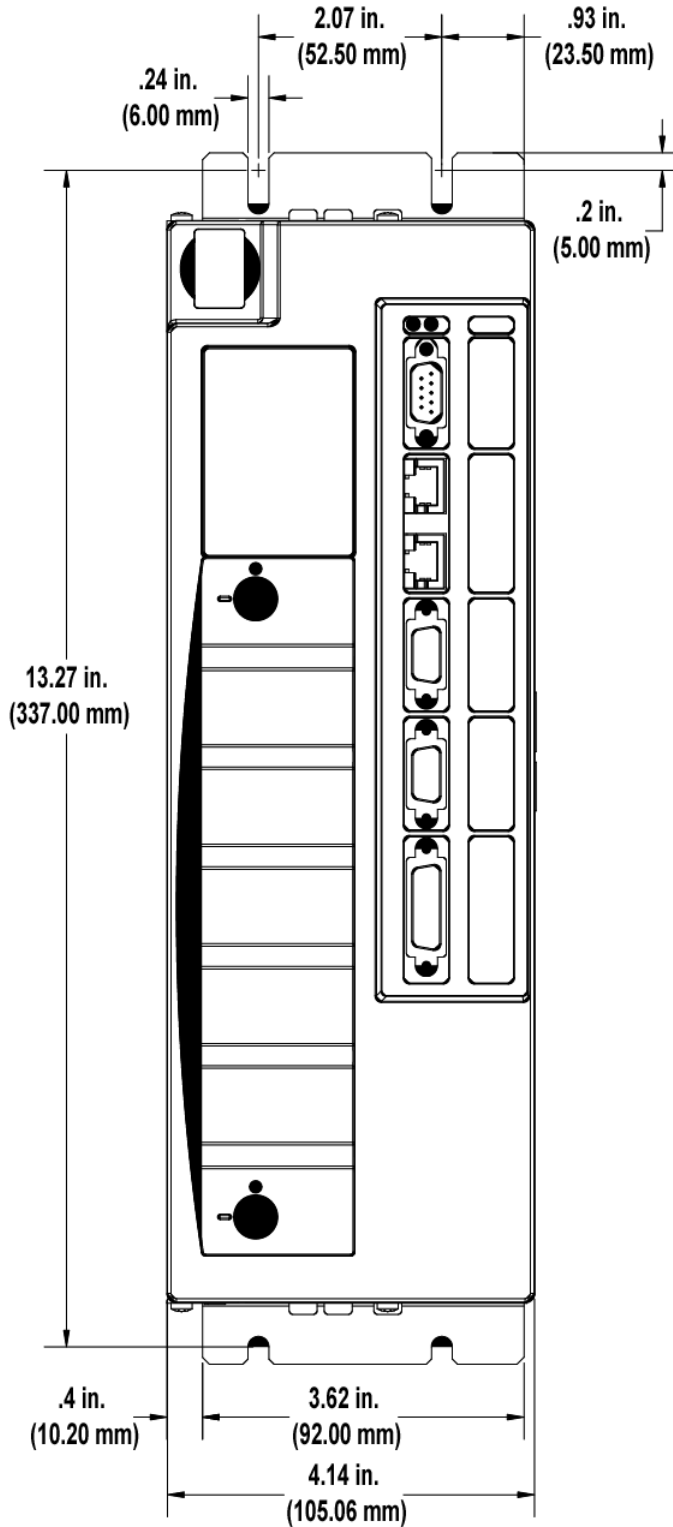


Figure 6-11: Size 1 460V Smart Drive - Side View

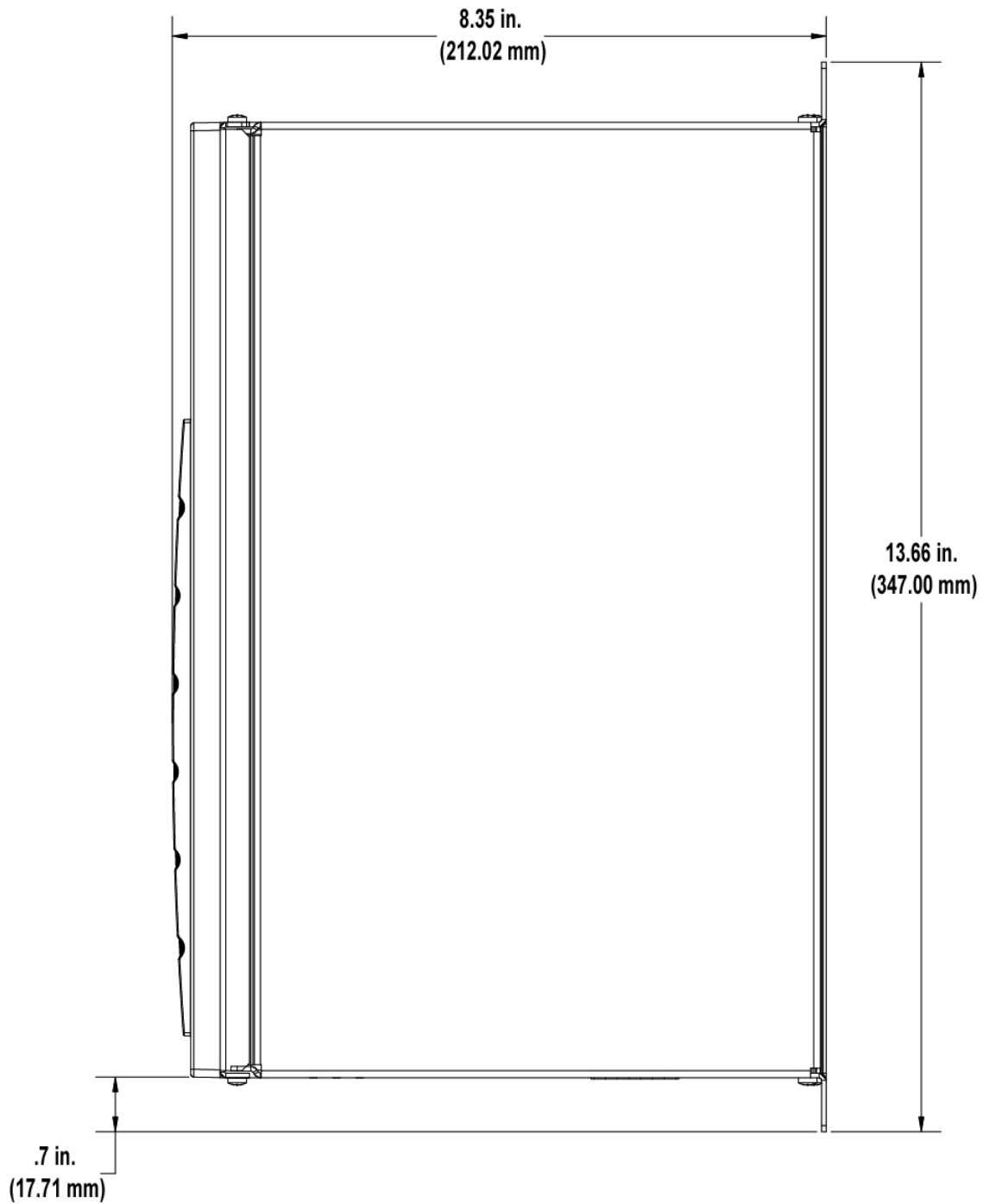


Figure 6-12: Size 2 460V Smart Drive - Front View

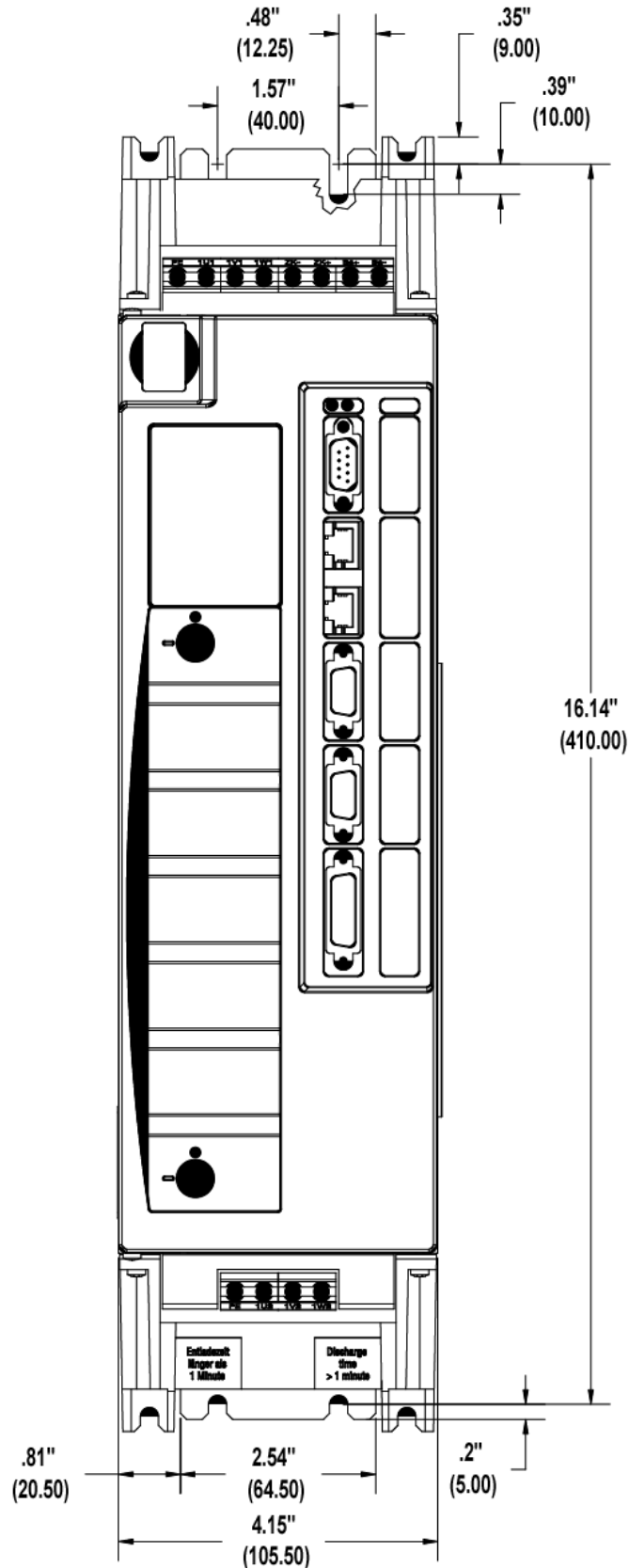


Figure 6-13: Size 2 460V Smart Drive - Side View

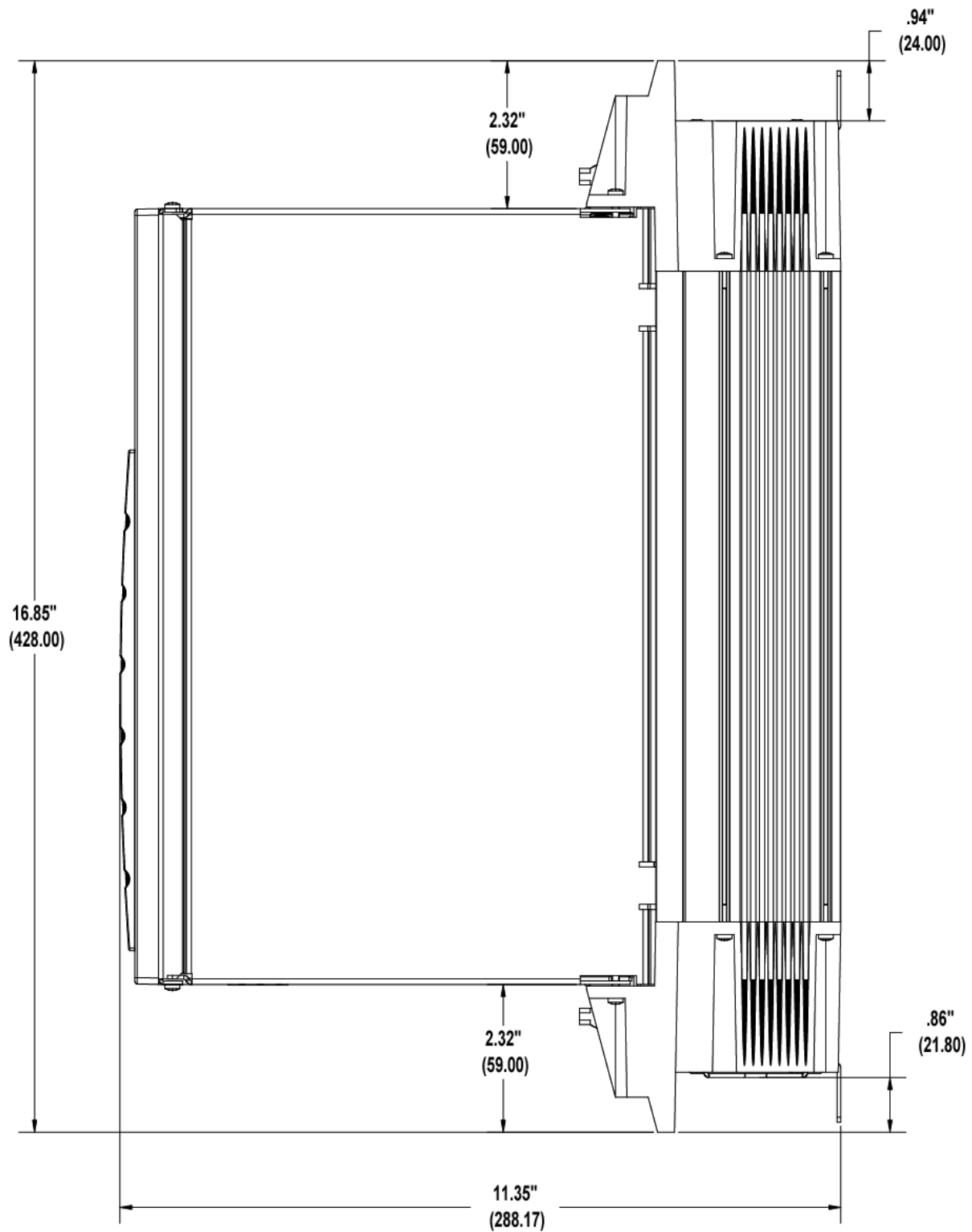




Figure 6-14: Size 3 460V Smart Drive - Front View

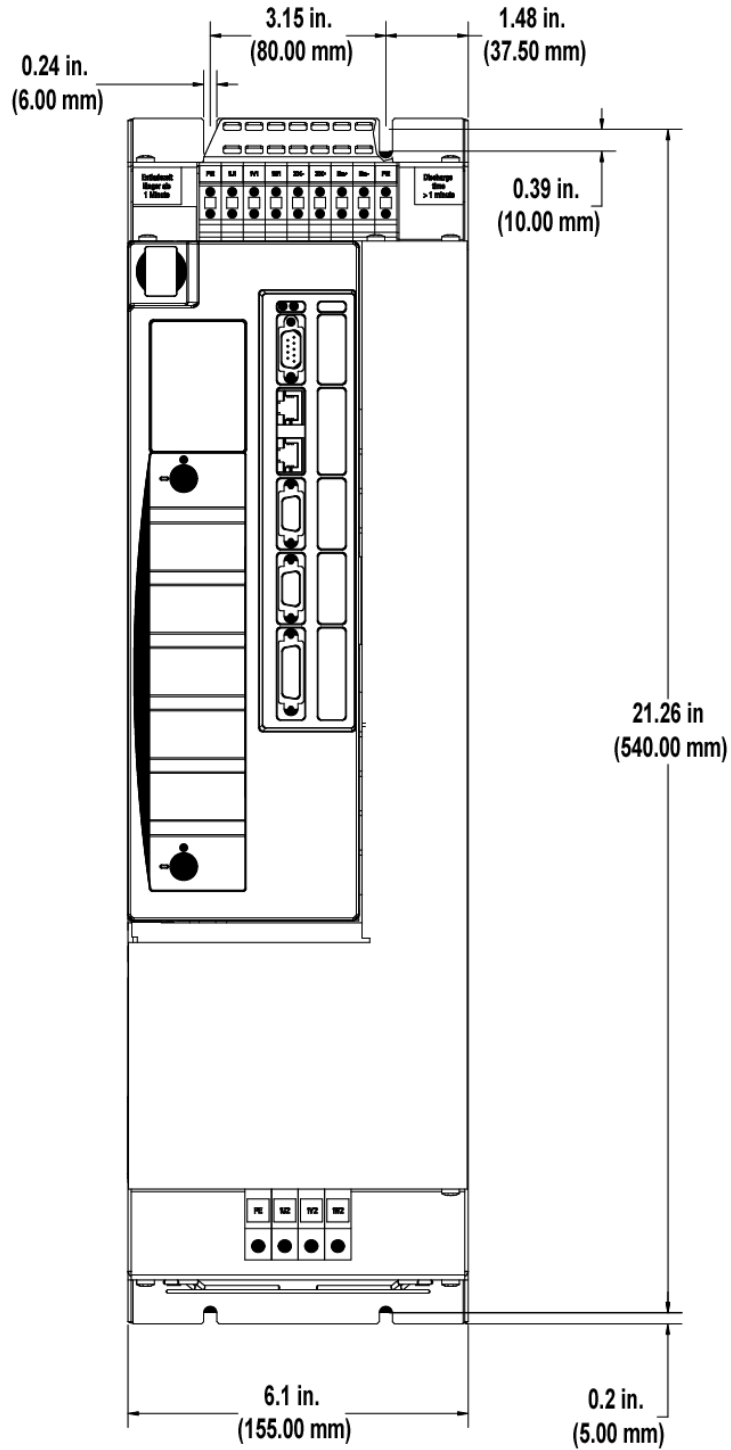


Figure 6-15: Size 3 460V Smart Drive - Side View

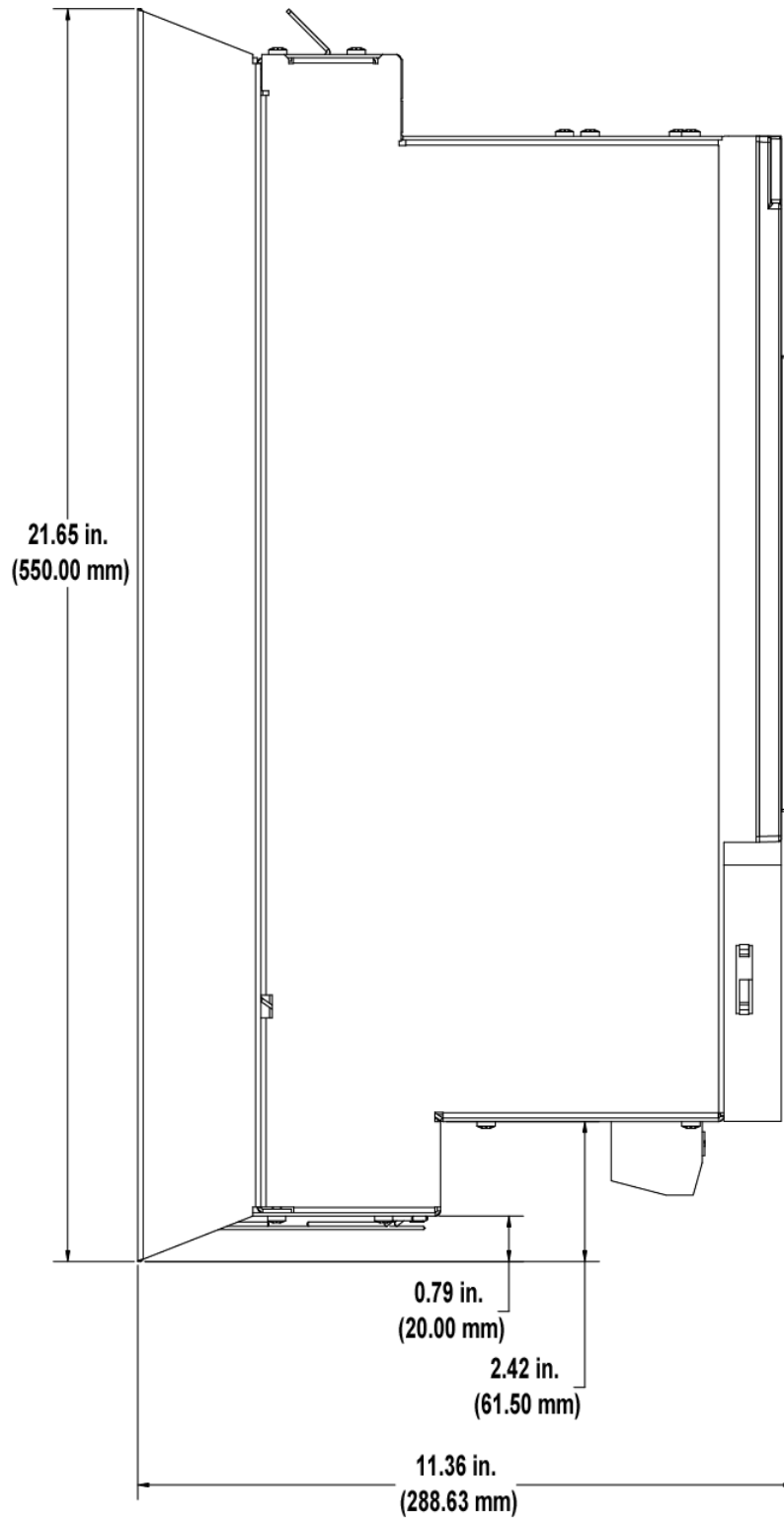
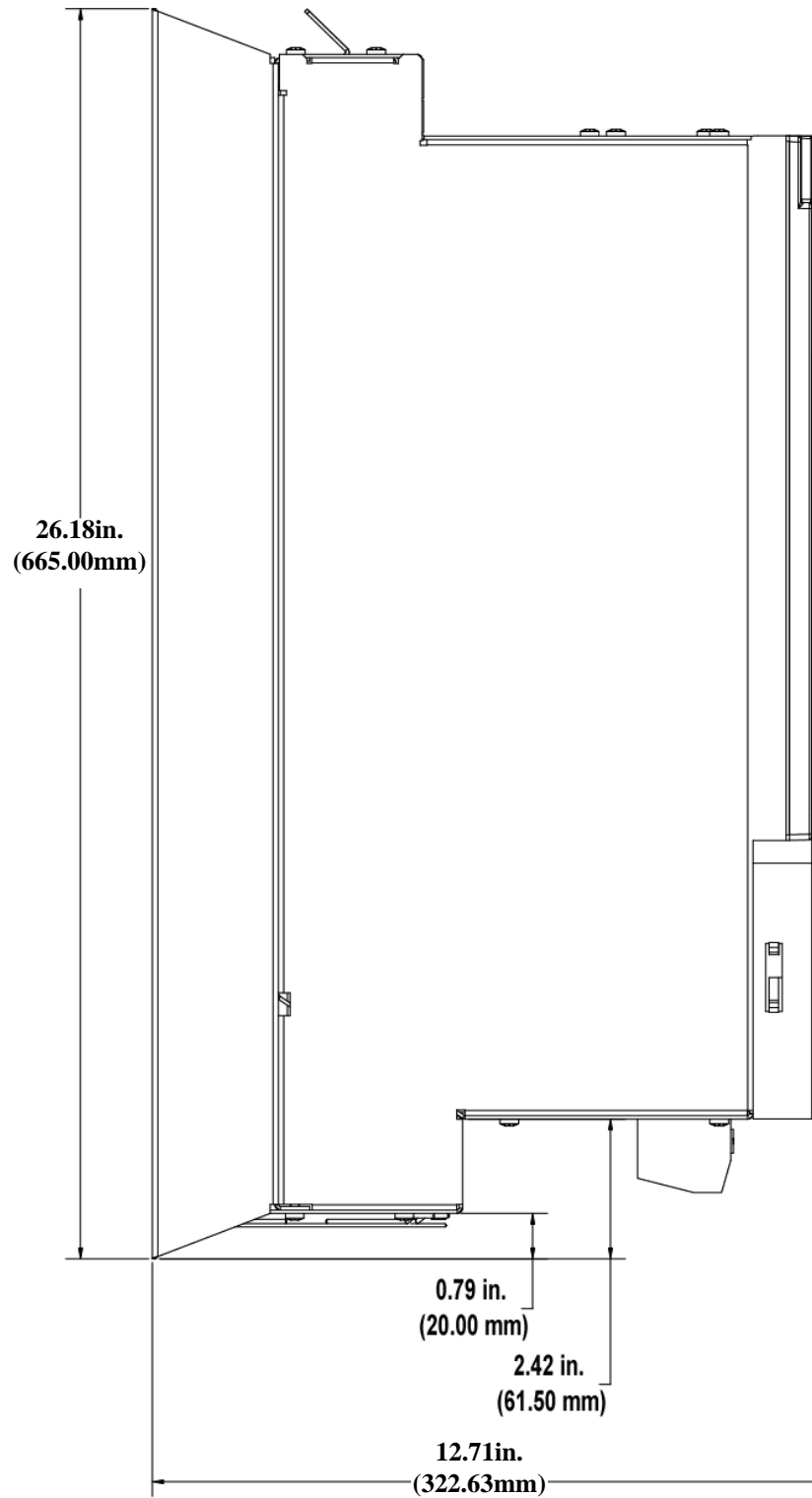




Figure 6-17: Size 4 460V Smart Drive - Side View



## 7 Cables and Connections to External Devices

### 7.1 Flex Cable Installation Guidelines

Follow these guidelines for any flexing cable application:

- Cable should be hung suspended for 48 hours to develop its most natural “set\* and lay” prior to installation
- A cable should be installed with, not against, its natural set
- Using strain relief fittings at both ends of the cable will reduce conductor breakage at the flex points
- If there is any kink in a cable after installation, it will always remain and eventually cause a cable failure
- After installation, the most critical factors in the cable are the minimum bend radius and the reel tension

\* Note: The natural set occurs during the manufacturing of the cable. The cable is cured in one direction on the reel with a notable difference in its ability to be flexed one way versus the other.

When using specially designed flex cables, the following five criteria must be considered:

- Bending Radius
- Cable Tension
- Operating Speed
- Temperature
- Ampacity

Bending Radius and Cable Tension are discussed in the following sections.

#### 7.1.1 Bending Radius

The following guidelines recommended by the ICEA standards are intended to optimize cable life:

- Minimum Bend Radius (Shielded Feedback Cables) = 12 times the Cable Diameter
- Minimum Bend Radius (Shielded Power Cables) = 12 times the Cable Diameter

Reduced bending radii result in reduced cable life due to increased stress on the copper conductors and overall distortion of the cable. Therefore, reduced radii should only be considered for applications in which other factors, such as reduced cable tension, lower operating speed, and ambient temperature are more favorable to cable life, or where the mechanical limitations of the installation do not allow the optimum radius.

Doubling the minimum bending radius for reeling applications can triple cable life at the maximum recommended tension. Therefore, the largest possible bending radius should be used to increase cable life.

#### 7.1.2 Cable Tension

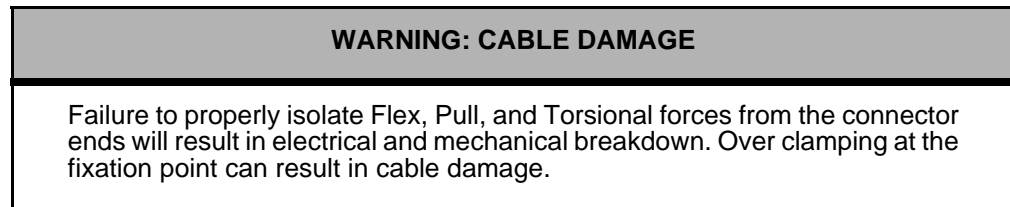
Cable tension plays an extremely important role in determining cable life in reeling. The copper conductors are the principle strength member in flexible cable

constructions. Even if strain relief fittings are used on the cable ends, most of the tension will still be supported by the copper conductors.

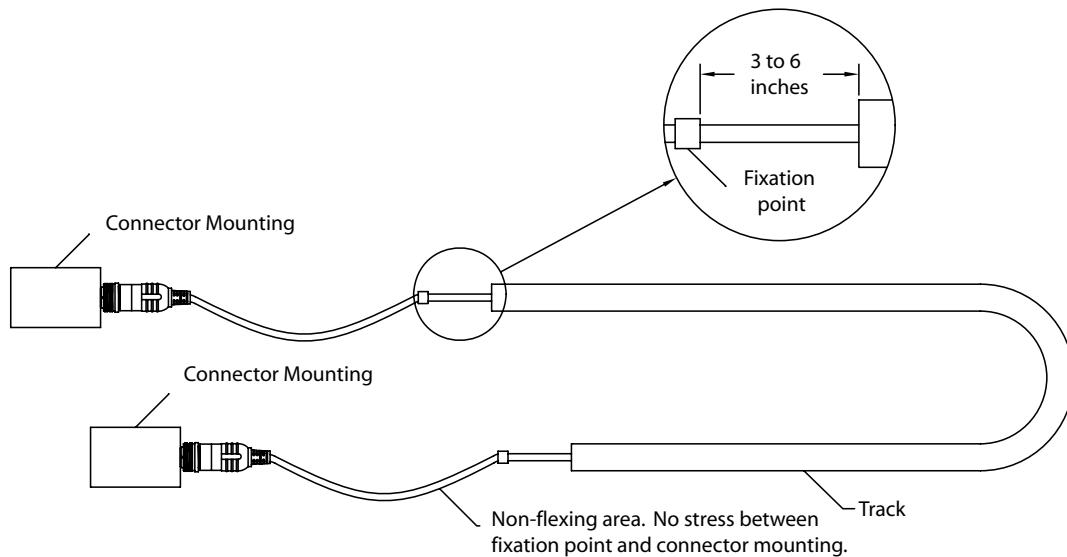
The effects of tension on a cable are dependent upon the pounds per cross-sectional area of the copper conductors. Larger AWG wires and/or more conductors can handle more tension than smaller AWG wires and/or fewer conductors.

## 7.2 Flex Cable Installation

Cables should be fixed on both ends to relieve them of tensile loads and prevent any loads from being applied to the molded connectors. At a minimum, the cables have to be fixed on the moving end of the track. A distance of 3 to 6 inches from the track to the fixation point is recommended (See [Figure 7-1](#)).



**Figure 7-1: Flex Cable Installation**

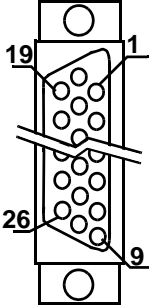
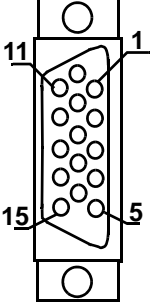



Observe the following precautions when installing flex cables:

- The cable must be able to move freely in the track
- The cable must be able to move in the radius section of the track. This must be checked in the track's fully extended position.
- When cables of different diameters are installed, the use of vertical separators or horizontal shelving is recommended. Cables of similar diameters can be put in the same compartment.

- Cables should never be put on top of one another in high velocity or high cycle applications.
- The cable's weight should be distributed symmetrically over the chain width.

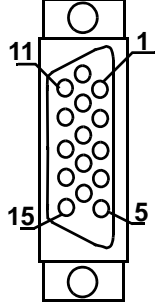
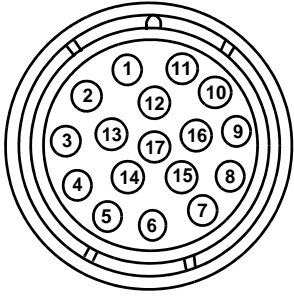

7.3 I/O Cable Pin Assignments

Table 7-1: I/O Cable to Controller (Analog Interfaced MMC-SD only)					
Twisted Pair 9 pair 28 AWG	D-sub 26-Pin HD Male Connector to MMC Smart Drive		D-sub 15-Pin HD Male Connector to MMC Controller		
					
Wire Color	Pin Number	Signal Type	Pin Number	Jumper Connection	Signal Type
Black	1	A	1		A
White/Black	2	A/	2		A/
Red	3	B	3		B
White/Red	4	B/	4		B/
Green	5	I	5		I
White/Green	6	I/	10		I/
Orange	26	OUT4	6		DCIN+
White/	N/U	N/U	7		DCIN-
Blue	14	CMD+	8		DA+
White/Blue	15	CMD-	9		DA-
Yellow	17	IN1	13		DCOUT1
White/Yellow	18	IN2	14		DCOUT2
Brown	N/U	N/U	N/U		N/A
White/Brown	N/U	N/U	15		DCOSS
Violet	N/U	N/U	N/U		N/A
White/Violet	N/U	N/U	N/U		N/A
Gray	10	IO24V	11		24VDCOUT
White/Gray	16	IOCOM	12		COM

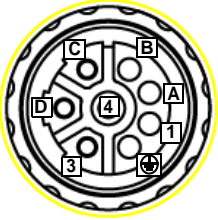
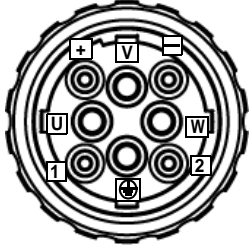



7.4 LSM and MSM Motors Cable Pin Assignments


Table 7-2: F1/F2 Motor Encoder Cable to LSM or MSM Motors

Wire Color	Pin Number	Signal Type	Pin Number	Jumper Connections	Signal Type
<p>Twisted Pair 8 pair 28 AWG 1 pair 16 AWG</p>					
<p>D-sub 15-Pin HD Male Connector to MMC Smart Drive</p> 			<p>Connector to Motor</p> 		
Yellow	1	A	1		A
White/Yellow	2	A/	2		A/
Blue	3	B	3		B
White/Blue	4	B/	4		B/
Black	5	I	5		I
White/Black	10	I/	6		I/
Violet	12	S1	15		S1
White/Violet	13	S2	16		S2
Red	8	S3	17		S3
White/Red	N/U	N/A	N/U		N/A
Green	11	TEMPERATURE	13		TEMPERATURE+
White/Green	N/U	N/A	14		TEMPERATURE-
Orange	N/U	N/A	N/U		N/A
White/Orange	N/U	N/A	N/U		N/A
Brown	7	9 VDC	9		9 VDC
White/Brown	N/U	N/A	N/U		N/A
Gray	14	+5 VDC	10		+5 VDC
White/Gray	6	COM	11		COM
N/C	9	N/A	7		N/C
N/C	15	N/A	8		N/C
			12	N/C	

**Table 7-3: Motor Power Connector to LSM or MSM Motors**

			Connector Pinout		
					
Wire Color	Wire Number	Signal Type	Size 1 Power Connector (Kit No. M.1302.0479)	Size 1.5.1 Power Connector (Kit No. M.1302.1998)	Size 1.5.2 Power Connector (Kit No. M.1302.2354)
Black (1)	1U2	Out	1		U
Black (2)	1V2	Out	3		V
Black (3)	1W2	Out	4		W
Green/ Yellow	PE	Ground	2		
Black (5)	Brake+	Out	A		+
Black (6)	Brake-	Out	B		-

**Table 7-4: Fan Motor Power Connector to LSM or MSM Motors**

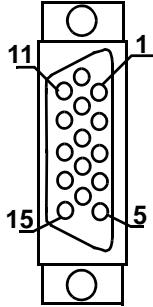
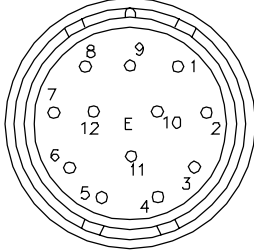
			Connector Pinout
			
Wire Color	Wire Number	Signal Type	Pin
Brown	U	Out	1
Black	N	Out	2
Green/Yellow	PE	Ground	3

7.5 AKM/DDR Motors Cable Pin Assignments

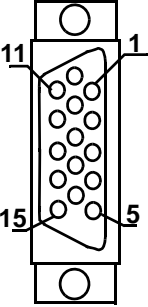
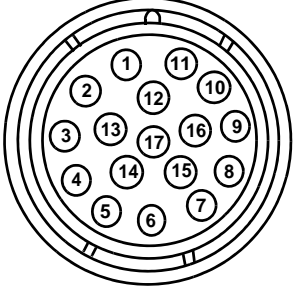

Table 7-5: F1/F2 Motor Encoder Cable to AKM/DDR Motor

Wire Color	Pin Number	Signal Type	Pin Number	Jumper Connections	Signal Type
Yellow	1	A	3		A
White/Yellow	2	A/	4		A/
Blue	3	B	1		B
White/Blue	4	B/	2		B/
Black	5	I	5		I
White/Black	10	I/	6		I/
Violet	12	S1	15		S1
White/Violet	13	S2	16		S2
Red	8	S3	17		S3
White/Red	N/U	N/A	N/U		N/A
Green	11	TEMPERATURE	8		TEMPERATURE+
White/Green	N/U	N/A	9		TEMPERATURE-
Orange	N/U	N/A	N/U		N/A
White/Orange	N/U	N/A	N/U		N/A
Brown	7	9 VDC	11		N/A
White/Brown	N/U	N/A	N/U		N/A
Gray	14	+5 VDC	10	+5 VDC	
White/Gray	6	COM	7	COM	
N/C	9	N/A	12	N/C	
N/C	15	N/A	13	N/C	
			14	N/C	

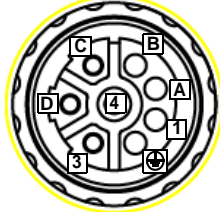
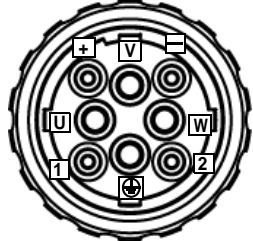
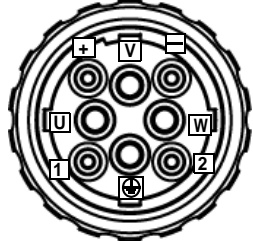

**Table 7-6: F1/F2 Motor Resolver Cable to AKM/DDR Motor**

Wire Color	Pin Number	Signal Type	Connector to Motor		
			Pin Number	Jumper Connections	Signal Type
Twisted Pair 4 pair 24 AWG		D-sub 15-Pin HD Male Connector to MMC Smart Drive		Connector to Motor	
					
Black	1	COS+	7		COS+
White/Black	2	COS-	3		COS-
Red	3	SIN+	8		SIN+
White/Red	4	SIN-	4		SIN-
Green	5	REF+	9		REF+
White/Green	10	REF-	5		REF-
Orange	11	TEMP+	2		TEMP+
White/Orange	6	COM	6		TEMP-
N/C	7	9 VDC	9		9 VDC
N/C	8	N/A	N/U		N/A
N/C	9	+5 VDC	10		+5 VDC
N/C	12	COM	1	N/C	
N/C	13	N/A	10	N/C	
N/C	14	N/A	11	N/C	
N/C	15	N/A	12	N/C	

**Table 7-7: F1/F2 Motor ENDAT/BiSS Cable to AKM/DDR Motor**

Wire Color	Pin Number	Signal Type	Pin Number	Jumper Connections	Signal Type
<p>15-Pin HD male D-sub Connector to MMC Smart Drive</p> 					
<p>Connector to Motor</p> 					
<p>Twisted Pair 7 pair 28 AWG 1 pair 16 AWG 1 pair 22 AWG</p>					
Wire Color	Pin Number	Signal Type	Pin Number	Jumper Connections	Signal Type
Yellow	1	COS	9		B+
White/Yellow	2	COS/	1		B-
Blue	3	SIN	11		A+
White/Blue	4	SIN/	3		A-
Black	5	DATA+	5		DATA
White/Black	10	DATA-	13		DATA/
Violet	12	CLOCK+	8		CLOCK
White/Violet	13	CLOCK-	15		CLOCK/
Red	N/U	N/A	12		UnSENSE VCC
White/Red	N/U	N/A	10		UnSENSE COM
Green	11	TEMPERATUR	7		THERMAL
White/Green	N/U	N/A	14		THERMAL
Orange	N/U	N/A	N/U		N/A
White/Orange	N/U	N/A	N/U		N/A
Brown	7	9 VDC	N/U		N/A
White/Brown	N/U	N/A	N/U		N/A
Gray	14	+5 VDC	4		5VDC
White/Gray	6	COM	2	GMD	
N/C	9	N/A	6	N/C	
N/C	15	N/A	16	N/C	
N/C	8	N/A	17	N/C	

**Table 7-8: Motor Power Connector to AKM/DDR Motor**

			Connector Pinout		
					
Wire Color	Wire Number	Signal Type	Size 1 Power Connector (Kit No. M.1302.0479)	Size 1.5.1 Power Connector (Kit No. M.1302.1998)	Size 1.5.2 Power Connector (Kit No. M.1302.2354)
Black (1)	U	Out	1		U
Black (2)	V	Out	4		V
Black (3)	W	Out	3		W
Green/ Yellow	PE	Ground	2		
Black (5)	Brake+	Out	A		+
White (6)	Brake-	Out	B		-

7.6 FSM Motors Cable Pin Assignments

Table 7-9: F1/F2 Motor Encoder Cable to FSM Motors

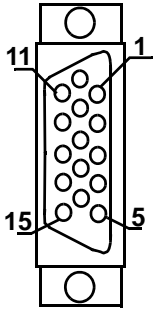
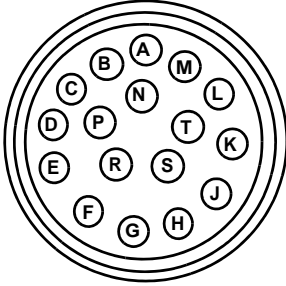

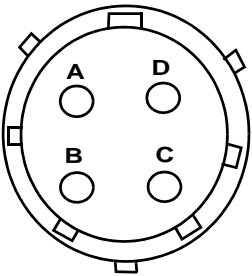

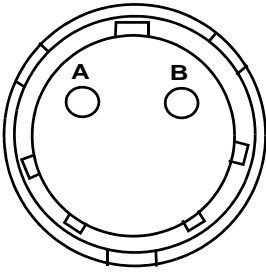
Twisted Pair, 28 AWG 16 AWG	D-sub 15-Pin HD Male Connector to MMC Smart Drive		Connector to Motor		
					
Wire Color	Pin Number	Signal Type	Pin Number	Jumper Connections	Signal Type
Black	1	A	A		A
White/Black	2	A/	B		A/
Red	3	B	C		B
White/Red	4	B/	D		B/
Green	5	I	E		I
White/Green	10	I/	F		I/
Gray	14	+5V	J		+5VDC
White/Gray	6	COM	K		+5VDC
			L		COM
			M		COM
			S		TEMPERATURE-
Blue	13	S2	N		S2
White/Blue	12	S1	T		S1
Brown	8	S3	P		S3
White/Brown	11	TEMPERATURE	R		TEMPERATURE+
Orange	N/U	N/A	N/U	N/A	
White/	N/U	N/A	N/U	N/A	
Violet	N/U	N/C	G	N/C	
White/Violet	7	N/C	H	N/C	
Yellow	9	N/C	N/U	N/A	
White/Yellow	15	N/C	N/U	N/A	



Table 7-10: Motor Power Cable to FSM Motors					
					
		Drive Lower Screw Terminal		Connector End to Motor	
Wire Color	Terminal	Signal Type	Pin Number	Signal Type	
Brown	U	Out	A	Out	
Black	V	Out	B	Out	
Blue	W	Out	C	Out	
Green/Yellow		Ground	D	Ground	

Motor Brake Cable Connector to FSM Motors	
	
Pin Number	Signal Type
A	B+
B	B-

7.7 YSM Motors Cable Pin Assignments

Table 7-11: F1/F2 Motor Encoder Cable to YSM Motors

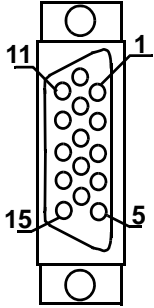
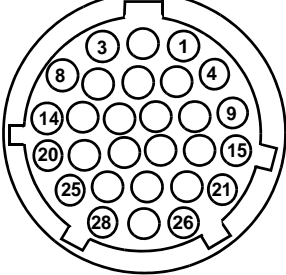
Twisted Pair, 28 AWG 16 AWG	D-sub 15-Pin HD Male Connector to MMC Smart Drive		Connector to Motor		
					
Wire Color	Pin Number	Signal Type	Pin Number	Jumper Connections	Signal Type
Black	1	A	9	NO JUMPERED PINS	A
White/Black	2	A/	10		A/
Red	3	B	11		B
White/Red	4	B/	12		B/
Green	5	I	13		I
White/Green	10	I/	14		I/
Gray	14	+5V	22		+5VDC
White/Gray	6	COM	23		COM
Blue	13	S2	17		S2
White/Blue	12	S1	15		S1
Brown	8	S3	19		S3
White/Brown	11	N/C	24		N/C
	7	N/C	1		N/C
	9	N/C	2		N/C
	15	N/C	3		N/C
			4-8	N/C	
			16	N/C	
			18	N/C	
			20	N/C	
			21	N/C	
			25-28	N/C	

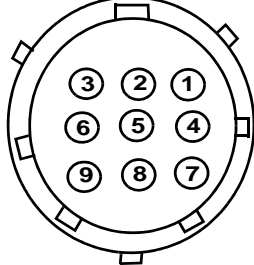

Table 7-12: Motor Power and Brake Cable to YSM Motors				
				
	Drive Lower Screw Terminal		Connector End to Motor	
Wire Color	Terminal	Signal Type	Pin Number	Signal Type
Brown	U	Out	1	Out
Black	V	Out	2	Out
Blue	W	Out	3	Out
N/A	N/U	N/A	4 (N/U)	N/A
Green/Yellow		Ground	5	Ground
N/A	N/U	N/A	6 (N/U)	N/A
N/A	N/U	N/A	8 (N/U)	N/A

Table 7-13: Motor Brake Cable Connector to YSM Motors	
Pin Number	Signal Type
7	B+
9	B-


### 7.8 Connecting Shunt Modules

Use shielded, high temperature 75° C (167° F), 600V, 2.5-4.0 mm<sup>2</sup> (12-14 AWG), 3.05 m (10 ft) maximum, copper wire. Follow one of the methods given below to reduce the effects of EMI noise:

- Install wires using twisted pairs (two turns per foot minimum), as shown in the figure above. Keep unshielded wires as short as possible.
- Use shielded, twisted cable (ground shield at shunt and drive).
- Use shielded metal conduit (ground conduit at shunt and drive).

When two shunt modules are connected in parallel, the shunt capacity is doubled.

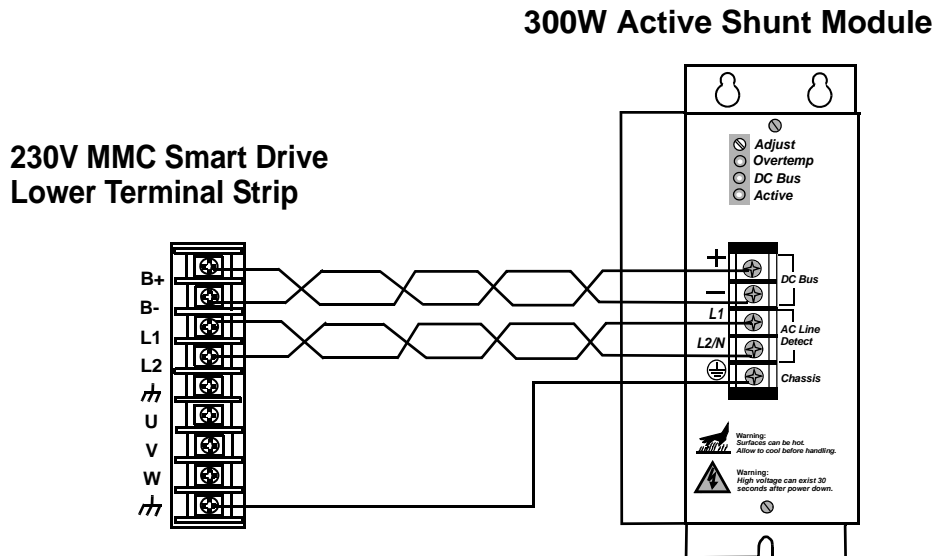
**WARNING**



Do not connect more than two shunt modules to an MMC Smart Drive.

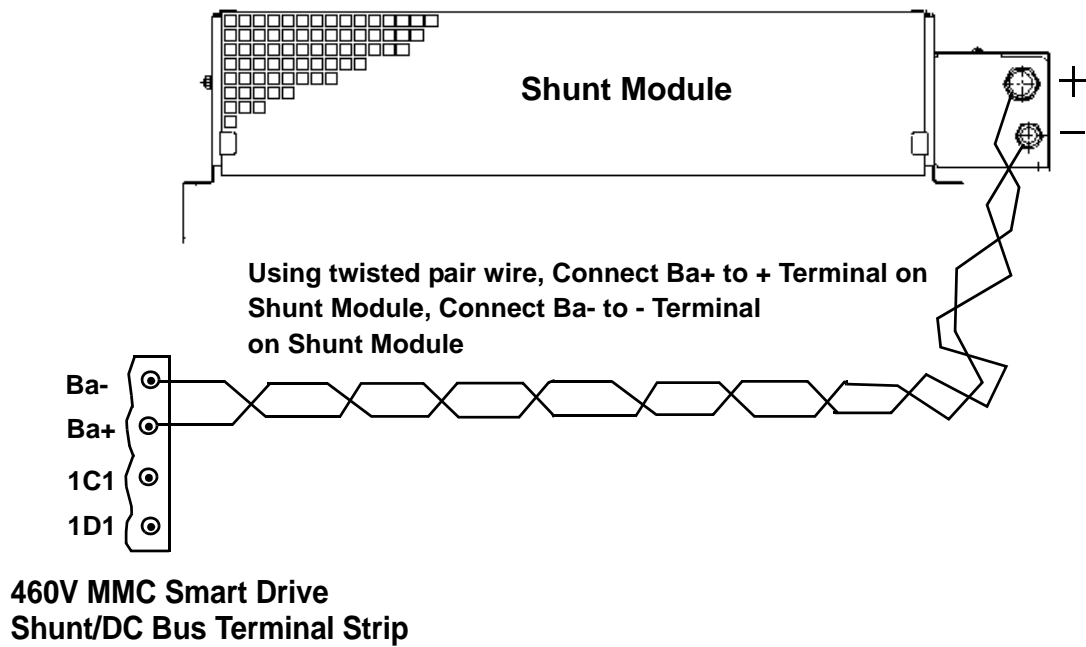
#### 7.8.1 Connecting the 230V MMC Smart Drive to 300 W Shunt Module

Figure 7-2: Wiring 230V MMC Smart Drive to 300W Active Shunt Module

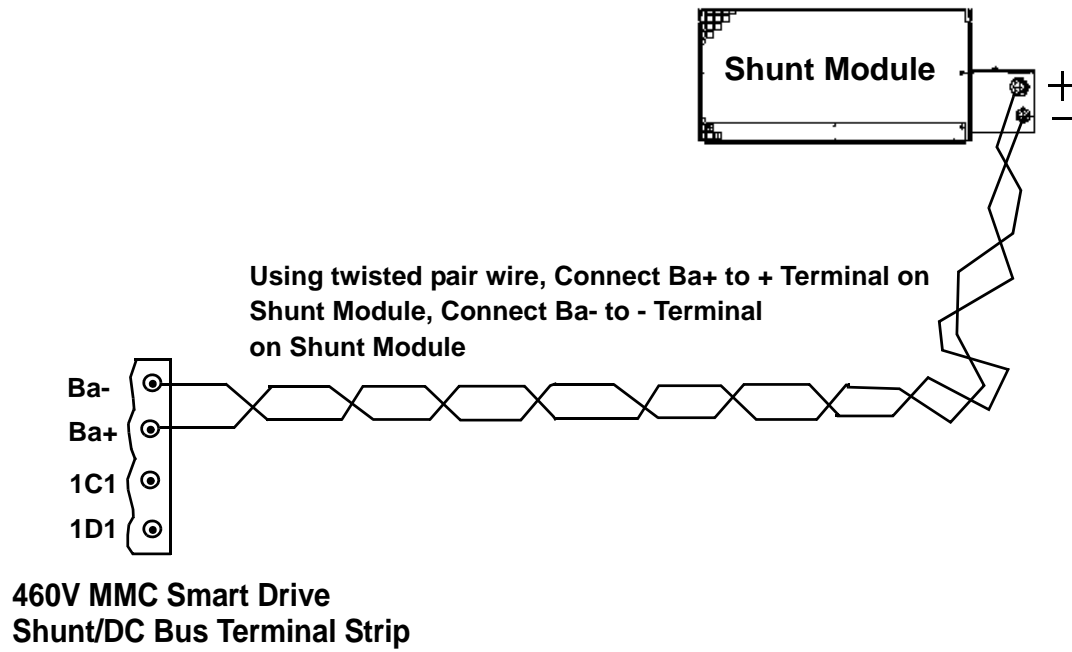


7.8.2 Connecting the 460V MMC Smart Drive to Danaher Motion Shunt Modules

Figure 7-3: Wiring 460V MMC Smart Drive to 450 Watt, 130Ω Shunt Module / 700 Watt, 95Ω Shunt Module / 1400 Watt, 50Ω Shunt Module

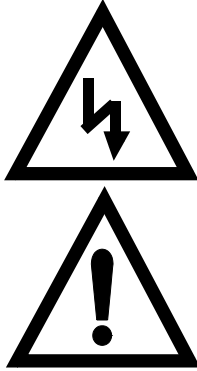


**Figure 7-4: Wiring 460V MMC Smart Drive to 2800 Watt, 25 $\Omega$  Shunt Module /  
3900 Watt, 18 $\Omega$  Shunt Module**



## 8 Maintenance and Troubleshooting

### 8.1 Maintenance

WARNING	
	<p>Disconnect input power before touching cables or connections.</p> <p>DC bus capacitors may retain hazardous voltages after input power has been removed.</p> <p>Before working on the drive, measure the DC bus voltage to verify it has reached a safe level.</p> <p>Failure to observe this precaution could result in severe bodily injury or loss of life.</p>

- Remove superficial dust and dirt from the drive.
- Check cable insulation and connections.
- Clean exterior surfaces and airflow vents using an OSHA approved nozzle that provides compressed air under low pressure of less than 20 kPa (30 psi).
- Visually check for cable damage. Replace all damaged cables.
- Inspect D-shell connectors for proper seating and signal continuity end-to-end.

### 8.2 Diagnostics

#### 8.2.1 Power-On Diagnostics

When the drive is powered up, it tests itself and reports the results of the tests in the form of LED signals.

##### 8.2.1.1 Power LED

If the Power (P) LED does not go on, or goes off during operation of the system, check that 24 VDC power is still connected to the drive.

##### 8.2.1.2 Diagnostic LEDs

The Status LED (D1) lights up briefly while diagnostic tests are running and then goes off. If the Status LED (D1) remains on, the drive has failed one of its diagnostic tests. Follow these steps:

1. Turn off power to the drive system and to the application.
2. Perform any necessary maintenance to the drive.
3. Check the I/O wiring and the devices the system is connected to. There may be a short or other problem other than the drive. Correct these problems.

4. Turn on power to check diagnostics again.

**NOTE**

Power-On diagnostics are run only when the system is powered up. If a drive fails during power-up, the Status LED (D1) light remains on. If you suspect that a drive is defective, cycle power to run diagnostics again.

## 8.2.2 Run-Time Diagnostics

While the MMC Smart Drive is running, other tests are performed on a regular basis with their results also reported through the Status LED (D1).

While the MMC Smart Drive is running, the Status LED (D1) will flash a two digit code signal if there is an error. The errors are described in [Table 8-1](#).

## 8.3 Troubleshooting

### 8.3.1 General Troubleshooting

Symptom	Possible Cause	Remedy
Power (P) indicator not ON	No 24VDC input power.	Verify 24 VDC power is applied to the drive.
	Internal power supply malfunction.	Contact your Danaher Motion representative.
Motor jumps when first enabled	Motor wiring error.	Check motor feedback and power wiring.
	Incorrect motor chosen.	Verify the proper motor is selected.
	Incorrect or faulty encoder	Replace the encoder with correct and/or functional encoder.
I/O not working correctly	I/O power supply disconnected.	Verify connections and I/O power source.

### 8.3.2 Troubleshooting Drive Diagnostic Fault Codes

When a Fault is detected, the drive is disabled and the Status LED (D1) located above the PICPro port on the face of the drive will flash a two-digit Fault code. The LED will continue to flash until the Fault is eliminated.

For example, if there is a long pause-flash-pause-flash-flash-long pause, the code is 12. The Drive Diagnostic Fault Codes are described in [Table 8-2](#).



<b>Table 8-2: Drive Diagnostic LED Fault Codes</b>			
<b>Fault Code</b>	<b>Fault</b>	<b>Possible Causes</b>	<b>Possible Remedies</b>
11	Drive Memory Fault	The drive's non-volatile memory is not functioning properly	Upgrade firmware. Contact Danaher Motion.
12	Drive Bus Over Voltage Fault	Excessive regeneration of power. The motor may regenerate too much peak energy through the drive's power supply. A fault is generated to prevent overload.	Change the deceleration or motion profile. Check shunt connections and where necessary, properly make connectons. Reduce the reflected inertia of your mechanical system. Use a larger motor and/or drive.
		Excessive AC input voltage.	Verify input AC voltage is within specifications. Adjust accordingly.
		Output short circuit.	Remove all power and motor connections, and perform a continuity check from the DC bus to the U, V, and W motor outputs. If a continuity exists, check for wire fibers between terminals, contact Danaher Motion
		Motor cabling wires shorted together.	Disconnect motor power cables from the drive. Test the cables for short circuits. Replace cable if necessary.
		Internal motor winding short circuit.	Disconnect motor power cables from the motor. If the motor is difficult to turn by hand, it may need to be replaced. Test winding resistance to confirm short circuit.
		230V motor used with a 460V drive and drive powered at 460V.	Set the drive for operation at 230V and apply 230V power to the drive.

Table 8-2: Drive Diagnostic LED Fault Codes (Continued)

Fault Code	Fault	Possible Causes	Possible Remedies
13	Drive PM1 Over Current Fault	Current feedback exceeds the drive over current fault limit.	Adjust the over current fault limit.
		Output short circuit.	Remove all power and motor connections, and perform a continuity check from the DC bus to the U, V, and W motor outputs. If a short exists, check for wire fibers between terminals, contact Danaher Motion
		Motor cabling wires shorted together.	Disconnect motor power cables from the drive. If faults stop, replace cable.
		Internal motor winding short circuit.	Disconnect motor power cables from the motor. If the motor is difficult to turn by hand, it may need to be replaced.
14	Drive Over Power Fault	Drive current and voltage output, in combination with the heatsink temperature indicate that the power output required by the drive would damage the power section.	Verify ambient temperature is not too high. Operate within the continuous power rating. Reduce acceleration rates. Check for mechanical load problems and adjust as necessary. Resize the application and apply components accordingly.
15	Motor Temperature Fault	Motor thermostat trips due to high motor ambient temperature	Operate within (not above) the continuous torque rating for the ambient temperature (40°C maximum). Lower ambient temperature, increase motor cooling. Check that motor is properly sized for the application. If necessary, resize the motor.
		Motor thermostat trips due to excessive current	Reduce acceleration rates. Increase time permitted for motion. Use larger drive and motor. Reduce duty cycle (ON/OFF) of commanded motion. Check tuning.
		Motor thermostat trips due to motor wiring error.	Check motor wiring.
		Motor thermostat trips due to incorrect motor selection.	Verify the proper motor has been selected.

<b>Table 8-2: Drive Diagnostic LED Fault Codes (Continued)</b>			
<b>Fault Code</b>	<b>Fault</b>	<b>Possible Causes</b>	<b>Possible Remedies</b>
16	Continuous Current Fault	Current exceeds the continuous motor current rating for an extended period of time.	Change motor and or drive to be compatible with load requirements. Check tuning.
17	Drive Heatsink Temperature Fault	Drive heatsink temperature exceeds drive heatsink fault limit	Let the drive cool down and/or reduce the load.
22	Drive F1 Feedback Fault	Error is detected in the motor feedback	Verify motor selection is correct. Check to be sure the correct encoder is attached. Verify encoder wiring is correct. Use shielded cables with twisted pair wires. Route the encoder feedback cable away from potential noise sources. Check ground connections.
23	Drive Ambient Temp. Fault	Drive ambient temperature exceeds the drive ambient temperature fault limit	Operate within (not above) the continuous rating for the ambient temperature. Lower ambient temperature, increase cabinet cooling.
24	Motor Calculated Temp. Fault	Motor calculated temperature exceeds the motor calculated temperature fault limit.	Check the machine for excessive loads. Motor may be undersized for the application.
25	Drive Timing Fault	Timing error is detected in the execution of the control algorithms performed by the drive's digital signal processor.	Contact Danaher Motion.
26	Drive Interface Fault	Communication error is detected in the transmission of information between the drive's digital signal processor and the drive's power section.	Contact Danaher Motion.
27	User Set Fault	PiCPro Set User Fault command selected.	The PiCPro Set User Fault command was selected or the Control Panel mode was activated or deactivated while the drive was enabled.

**Table 8-2: Drive Diagnostic LED Fault Codes (Continued)**

<b>Fault Code</b>	<b>Fault</b>	<b>Possible Causes</b>	<b>Possible Remedies</b>
31	Drive F1 Communication Fault	Communication error is detected in the transmission of information between the drive and a high resolution or multi-turn absolute feedback device.	Check encoder line and make sure the correct encoder is attached. Verify encoder wiring is correct. Use shielded cables with twisted pair wires. Route the encoder feedback cable away from potential noise sources. Check ground connections. Verify motor selection is correct.
		Bad encoder.	Replace motor and encoder.
32	Over Speed Fault	User specified motor speed has been exceeded.	Check cables for noise. Check tuning.
33	Over Current Fault	User-Specified average current level has been exceeded.	Change to a less restrictive setting. Reduce the load.
34	Drive Communication Fault	Communication error occurs while drive control is being performed using the PiCPro Control Panel tools.	Do not disconnect the PiCPro cable while operating in Control Panel Mode.
35	Drive Power Module Fault	The drive's power section detects a fault condition.	Verify AC power is applied to drive. Contact Danaher Motion.
36	Drive Setup Data Fault	The configuration data has been corrupted.	Re-download Drive Setup Data.
41	Drive Relay Fault	The drive's power section relay did not function properly during power-up.	Check the drive system connections. Adjust as necessary. Contact Danaher Motion.

<b>Table 8-2: Drive Diagnostic LED Fault Codes (Continued)</b>			
<b>Fault Code</b>	<b>Fault</b>	<b>Possible Causes</b>	<b>Possible Remedies</b>
42	Drive PM2 Over Current Fault	Current feedback exceeds the drive over current fault limit.	Adjust the over current fault limit.
		Output short circuit.	Remove all power and motor connections, and perform a continuity check from the DC bus to the U, V, and W motor outputs. If a continuity exists, check for wire fibers between terminals, contact Danaher Motion.
		Motor cabling wires shorted together.	Disconnect motor power cables from the drive. If faults stop, replace cable.
		Internal motor winding short circuit.	Disconnect motor power cables from the motor. If the motor is difficult to turn by hand, it may need to be replaced.
43	Drive PM Over Temperature Fault	Drive power module temperature exceeds the drive power module temperature fault limit	Check to be sure that the drive is being operated within the continuous power rating. Check for adequate enclosure ventilation. Ensure cooling air flow is adequate in space around the drive. Check for clogged vents or defective fan. Contact Danaher Motion.
44	Motor Ground Fault	Ground fault has occurred.	Make sure motor ground connections are correct. Replace defective motor ground wires. Check for internal motor winding short circuits.
45	Drive AC Input Over Voltage Fault	Incoming AC voltage is too high.	Verify input VAC is within specifications.

Table 8-2: Drive Diagnostic LED Fault Codes (Continued)

Fault Code	Fault	Possible Causes	Possible Remedies
46	Overtravel Plus Fault	Overtravel Plus Fault input is off and Drive Ignore Plus Travel Limit is off.	Overtravel Plus Fault status can be monitored using READ_SV variable 68 AND (16#400 0000). Fault input write a 0 to WRITE_SV variable 86. Use DRSETFLT to reset fault indications. To override the Overtravel Plus Fault input write a 1 to WRITE_SV variable 86, Ignore Plus Travel Limit. To reactivate checking of the Overtravel Plus input write a 1 to WRITE_SV variable 86, Ignore Plus Travel Limit. To reactivate checking of the Overtravel Plus Fault input write a 0 to WRITE_SV variable 86.
47	Overtravel Minus Fault	This fault is set when the Overtravel Minus Fault input is off and Drive Ignore Minus Travel Limit is off.	Overtravel Minus Fault status can be monitored using READ_SV variable 68 AND (16#800 0000). Use DRSETFLT to reset fault indications. To override the Overtravel Minus Fault input write a 1 to WRITE_SV variable 87, Ignore Minus Travel Limit. To reactivate checking of the Overtravel Minus Fault input write a 0 to WRITE_SV variable 87.
51	Digital Link Communication Error	This fault is set when two consecutive corrupt Digital Link messages are detected or no Digital Link messages are received within 250 microseconds.	Digital Link Communication Error status can be monitored using READ_SV variable 68 AND (16#1000 0000). This fault requires that the user servo setup function and DSTRTSRV be executed prior to executing DRSETFLT to reset the fault indication.
52	Invalid Switch Setting Fault	This fault is set when the drive address switch setting is set to 0 or greater than 64 or its setting is changed while the Digital Link is operating in cyclic communications mode.	Invalid Switch Setting Fault status can be monitored using READ_SV variable 68 AND (16#2000 0000). Use DRSETFLT to reset fault indications. <b>Note:</b> Digital Link initialization must be performed before this fault can be reset.
77	Drive Not Ready	Power applied to an uninitialized drive.	Initialize and configure the drive using PICPro.

### 8.3.3 Troubleshooting Drive Diagnostic Warning Codes

Warning conditions give the user an indication of a potential problem, but do not disable the drive. Whenever a Warning condition is detected, the drive generates a Warning code. The user can detect a Warning Code in two ways:

- by examining the Drive Maintenance page in PiCPro under “Faults and Warnings”
- by reading the Warning Code using READ\_SV variable 69 from within the user's Ladder.

The Drive Diagnostic Warning Codes are described in [Table 8-3](#).

<b>Table 8-3: Drive Diagnostic Warning Codes</b>			
<b>Error Code</b>	<b>Warning</b>	<b>Possible Causes</b>	<b>Possible Remedies</b>
01	Drive Heatsink Temp. Warning	Drive heatsink temperature exceeds warning limit	<ul style="list-style-type: none"> <li>• Lower the ambient temperature around the drive.</li> </ul>
02	Drive Ambient Temp. Warning	Acceptable ambient temperature limit has been exceeded warning limit	
03	Motor Temp. Warning (available only when the motor contains a thermistor)	Thermistor temperature has exceeded user defined acceptable limit.	<ul style="list-style-type: none"> <li>• Reduce acceleration rates.</li> <li>• Reduce duty cycle (ON/OFF) of commanded motion.</li> <li>• Increase time permitted for motion.</li> <li>• Use larger drive and motor.</li> <li>• Check tuning.</li> </ul>
04	Motor Calculated Temp. Warning (available only when the motor does not contain a thermistor).	Calculated motor temperature has exceeded acceptable limit	
05	Overtravel Plus Warning	The Overtravel Plus Fault input is low because the axis has reached the Plus Travel Limit.	Move the axis off the Plus Limit Switch in the negative direction.
06	Overtravel Minus Warning	The Overtravel Minus Fault input is low because the axis has reached the Minus Travel Limit.	Move the axis off the Minus Limit Switch in the positive direction.





## 9 Resolver Interface Option Module

### 9.1 Theory of Operation

The Resolver Interface Option Module provides the interface between the resolver and the drive's DSP. It is a tracking system where the rotor is excited with a sine wave. The outputs of the resolver are amplitude modulated by the sine and cosine of the rotor shaft angle. The tracking converter converts the sine and cosine amplitude ratio into a 12 bit number.

The module provides a 4 Vrms 5 kHz sine wave to excite the resolver rotor. The resolver transformer ratio is .5:1 so the stator outputs are 2V RMS with the shaft rotated to the angle of maximum coupling. The sine and cosine rotor outputs are returned to the resolver module's twin instrumentation amplifier inputs to produce a high common mode noise rejection and a high input impedance (220K  $\Omega$ ). The sine and cosine signals are then fed to a resolver to digital converter chip that performs the tracking conversion. The converter has both a serial output and an encoder emulator output. The serial output is read when the drive is powered up to obtain the absolute commutation angle for the motor. Thereafter, it is used as an encoder emulator.

The module is able to detect a loss of feedback by monitoring the sine and cosine signals. If both are near zero at the same time, a loss of feedback error is generated.

### 9.2 Installing the Resolver Module

1. If the Resolver Module is being installed in a 230V drive, remove the five screws at the corners of the cover and remove the cover. If the Resolver Module is being installed in a 460V drive, turn the 2 locking screws on the front of the drive clockwise and remove the MMC Smart Drive board from the drive chassis.
2. Remove the shunt from the 24-pin DIP socket located on the MMC Smart Drive board (See Figure 9-1 on page 162).
3. If there are not two standoffs already installed on either side of the 24-pin DIP socket on the MMC Smart Drive board, proceed to step 10.
4. If there are nylon standoffs snapped into the Resolver Module, remove and discard them. If there are nylon standoffs included with the Resolver Module, discard them.
5. Remove and save the two nylon screws that are threaded into the standoffs mounted to the MMC Smart Drive board.
6. Position the Resolver Module so the mounting holes align with the standoffs, and the header is aligned with the socket (See Figure 9-2 on page 163).
7. Using even pressure, press the option module into place.
8. Screw the Resolver Module to the standoffs using the screws removed in step 5.
9. Verify that the module is fully seated into the socket and proceed to step 15.
10. If there are standoffs installed in the Resolver Module, proceed to step 12.
11. Install the snap-in standoffs that were included with the Resolver Module into the Resolver Module. From the back of the Resolver Module (the side that has the 24-pin header on it), insert the short (slotted) end of the standoffs into the mounting holes.
12. Position the Resolver Module so the long (locking tab) end of the standoffs line up with the mounting holes on the Drive board, and the header is aligned with the socket (See Figure 9-2 on page 163).

13. Using even pressure, press the option module into place.
14. Verify that the module is fully seated into the socket and the locking tabs on the standoffs are in the locked position.
15. If the Resolver Module was installed in a 230V drive, re-install the cover and five screws removed in step 1. If the Resolver Module was installed in a 460V drive, re-install the MMC Smart Drive board into the chassis and turn the 2 locking screws on the front of the drive counter-clockwise to secure the front panel to the chassis.

**Figure 9-1: : Before Shunt Removed and Resolver Module Installed**

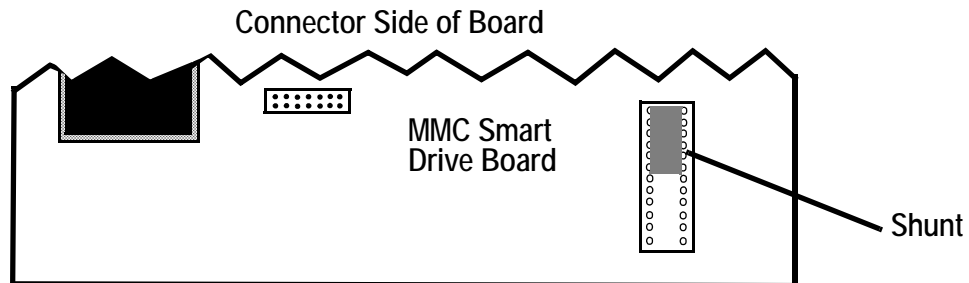
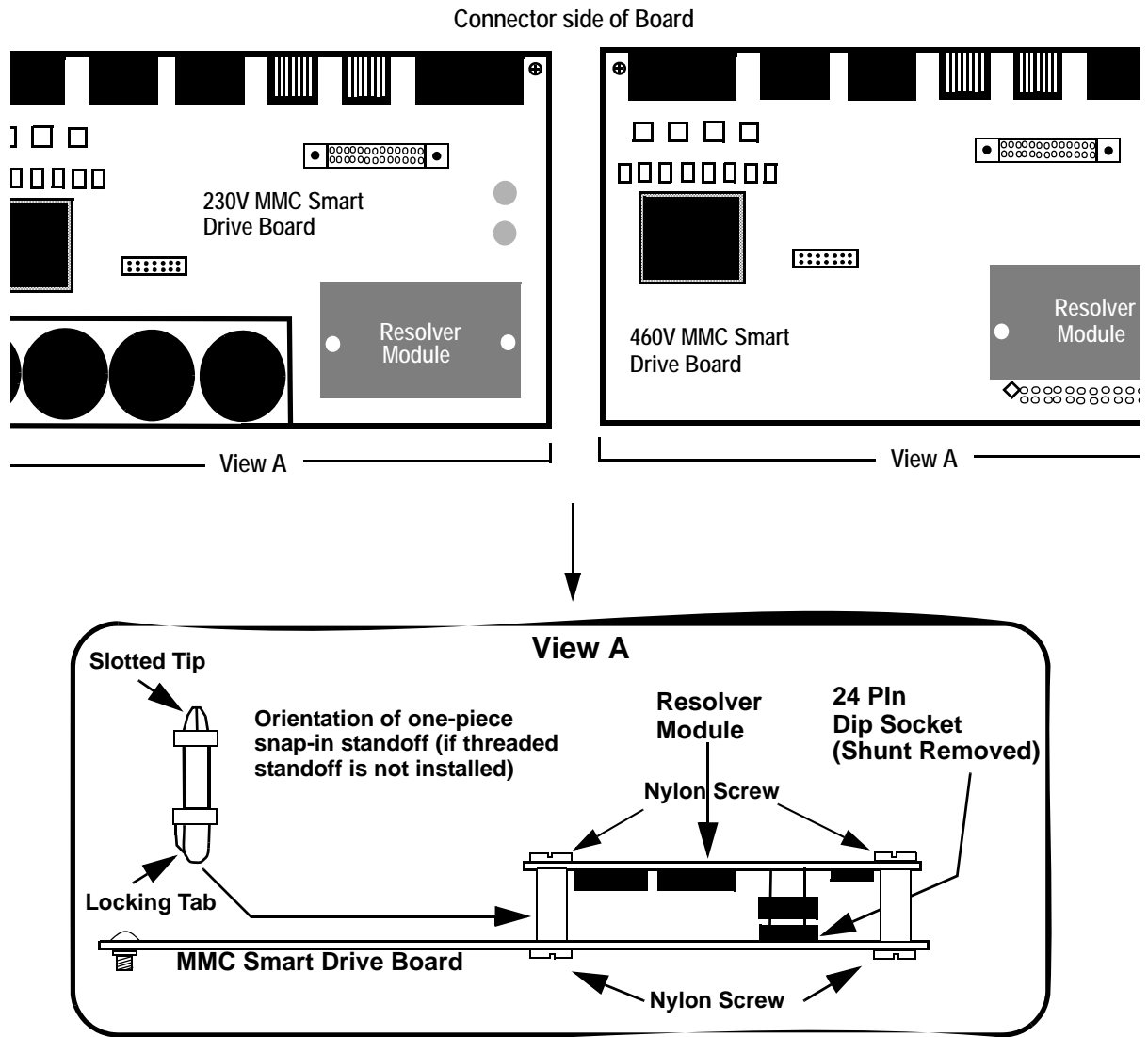


Figure 9-2: : Shunt Removed and Resolver Module Installed



**9.3 Specifications**

<b>Characteristics</b>	<b>Resolver Interface Option Module Specifications</b>
Function	Resolver to encoder converter
Part Number	M.1302.4523
Field Side Connector	F1 Feedback Connector
Excitation Frequency	5 kHz
Output Voltage	4 V <sub>RMS</sub>
Current per Output Channel, max.	28 mA <sub>RMS</sub>
Resolver Transformer Ratio	0.5:1.0
Resolver Resolution	4096 Feedback Units (FUs) per electrical revolution
Accuracy Over Temperature Range	+ 15 minutes
Electrical Velocity, max.	500 RPS
Cable Length, max.	30 M
Power	Powered from MMC Smart Drive

## **10 Drive Resident Digital MMC Control**

### **10.1 Introduction**

This section contains information for the Drive Resident Digital MMC Control (Digital MMC-Dx). Block I/O information can be found in the Block I/O Modules Manual. Software information can be found in the PiCPro Online Help, the Function/Function Block Reference Guide, ASFB Manuals or on-line.

#### **10.1.1 Overview**

The Drive Resident Digital MMC Control offers a complete solution to both machine and motion control in a module that is installed into any Digital Interfaced Smart Drive (MMC-SD-D) except the 230V Narrow Drive (-DN). One Drive Resident Digital MMC Control can control from 1 to 16 drives as follows:

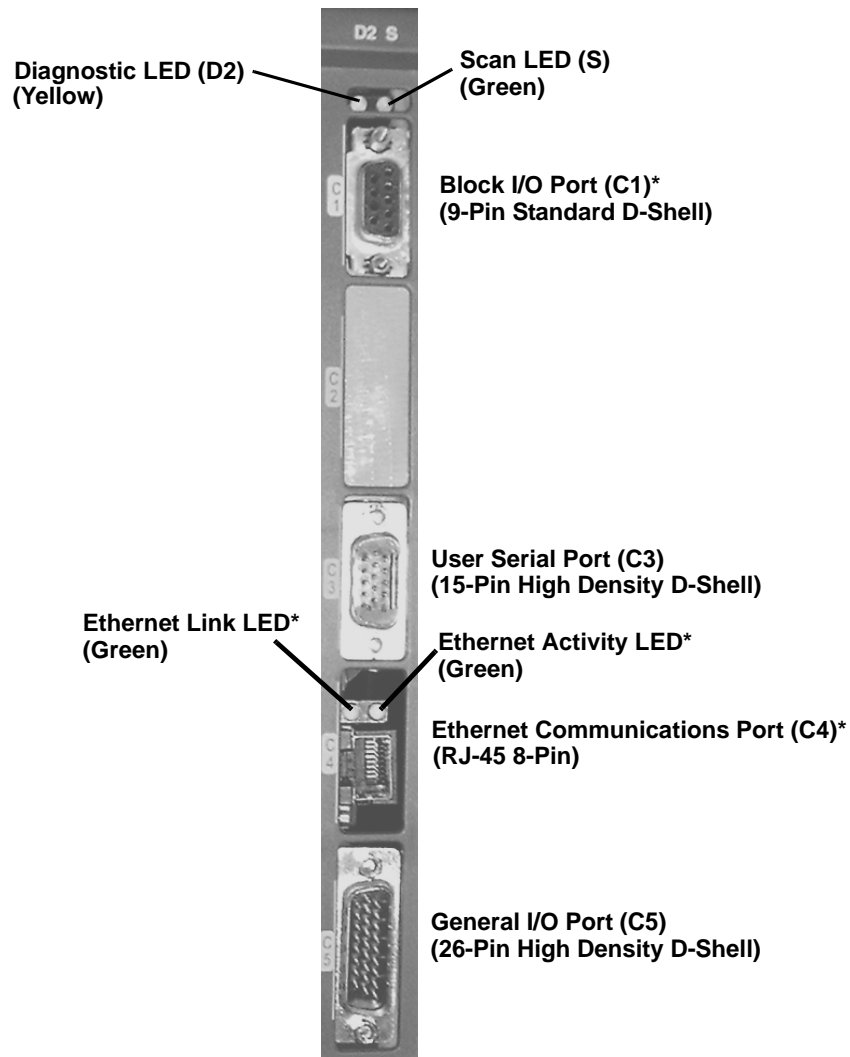
- Digital MMC-D1 (controls one MMC-SD-D)
- Digital MMC- D2 (controls two MMC-SD-D)
- Digital MMC- D4 (controls four MMC-SD-D)
- Digital MMC- D8 (controls eight MMC-SD-D)
- Digital MMC- D16 (controls 16 MMC-SD-D)

PiCPro is used to program the Drive Resident Digital MMC Control. The built-in I/O (eight 24VDC inputs and eight 24VDC outputs) can be expanded using Danaher Motion serially distributed block I/O (not included on the Digital MMC-D1).

#### **10.1.2 Major Components**

The Drive Resident Digital MMC Control contains the CPU, a User Serial port, a Block I/O port, an Ethernet port, and a General I/O port consisting of 8 DC inputs and 8 DC outputs.

**Figure 10-1: The Drive Resident Digital MMC Control**



\* The Block I/O Port connector (C1), Ethernet Communications Port connector (C4), Ethernet Link LED, and Ethernet Activity LED are present on the Digital MMC-D1 Control, but are not functional.

## 10.2 Installing the Drive Resident Digital MMC Control

### 10.2.1 Installing into a 230V MMC-SD Drive

1. Remove the three screws from the right side of the cover and one screw from the top and bottom of the drive near the front. Remove the cover.
2. Place the cover removed in step 1 on a flat surface, with the blue plastic faceplate down, and the large side cover to the left pointing up.
3. Remove the two screws that hold the .6" by 8" blue filler plate to the back of the faceplate and remove the plate.
4. Locate the 4 screws that secure the top-most printed circuit board into the drive. Remove one of the screws and the associated lock washer, and install one of the four threaded standoffs that were included with the Drive Resident Digital MMC Control (do not use the lock washer). Repeat this process for the other 3 screws, one at a time.
5. Place the Drive Resident Digital MMC Control into the drive, with the connectors facing towards the front of the unit. Align the 20-pin connector on the Drive Resident Digital MMC Control with the 20-pin connector on the drive. Press the Drive Resident Digital MMC Control onto the drive until the 20-pin connector is completely seated and the Drive Resident Digital MMC Control is seated against the threaded standoffs installed in step 4.
6. Fasten the Drive Resident Digital MMC Control onto the threaded standoffs using the lockwashers and screws removed in step 4.
7. Replace the cover using the 4 screws removed in step 1.

### 10.2.2 Installing into a 460V MMC-SD Drive

1. Turn the two locking screws on the front of the drive clockwise  $\frac{1}{4}$  turn and pull the drive control board unit out of the drive.
2. Place the drive control board unit removed in step 1 on a flat surface, with the blue plastic faceplate down, and the drive control board to the left.
3. Remove the two screws that hold the .6" by 8" blue filler plate and remove the plate.
4. Place the drive control board unit on a flat surface so that the control board is facing up, and the blue plastic faceplate is facing away from you.
5. Locate the 4 screws that secure the top-most printed circuit board into the drive. Remove one of the screws and the associated lock washer, and install one of the four threaded standoffs that were included with the Drive Resident Digital MMC Control (do not use the lock washer). Repeat this process for the other 3 screws, one at a time.
6. Place the control board unit on a flat surface, with the blue plastic faceplate down, and the drive control board to the left.
7. Loosen (but do not remove....about 2 turns) the 5 screws that hold the drive control board mounting plate to the front cover plate.
8. Place the Drive Resident Digital MMC Control into the drive, inserting the connectors on the Drive Resident Digital MMC Control through the front plate.
9. Align the 20-pin connector on the Drive Resident Digital MMC Control with the 20-pin connector on the drive. Press the Drive Resident Digital MMC Control onto the

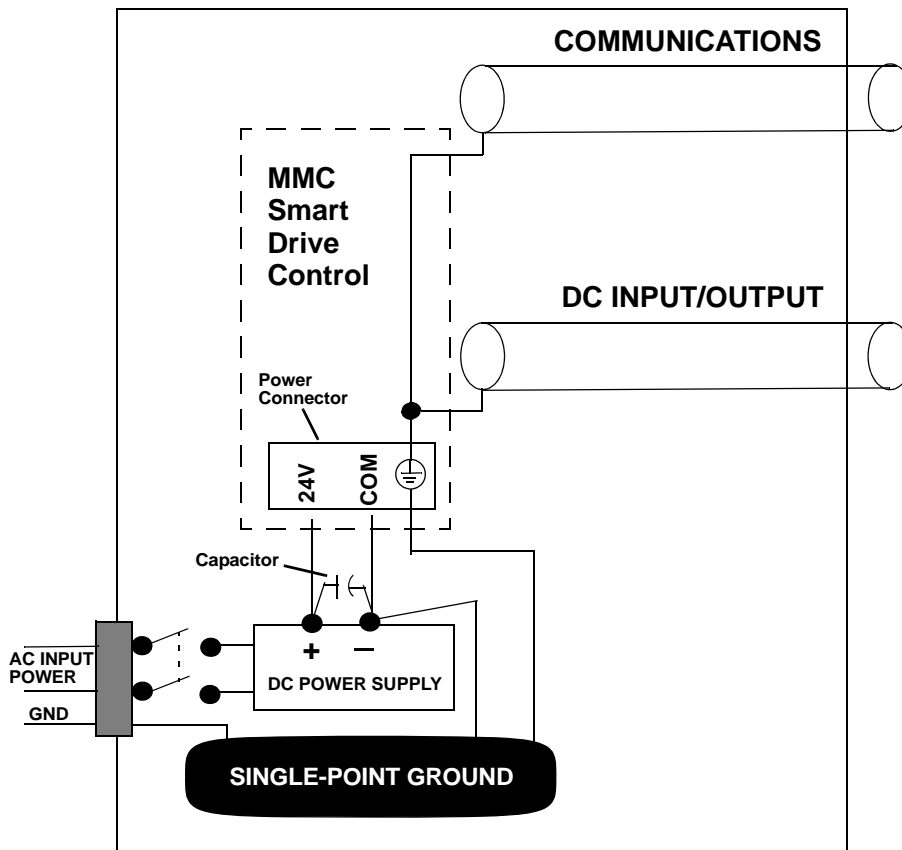
drive until the 20-pin connector is completely seated and the Drive Resident Digital MMC Control is seated against the threaded standoffs installed in step 5.

10. Tighten the 5 screws loosened in step 7
11. Fasten the Drive Resident Digital MMC Control onto the threaded standoffs using the lockwashers and screws removed in step 5.
12. Replace the control board unit back into the drive, and turn the locking screws  $\frac{1}{4}$  turn counter-clockwise to secure the unit in place.

### 10.3 System Wiring Guidelines

The Drive Resident Digital MMC Control relies on electrical signals to report what is going on in the application and to send commands to it. In addition, signals are constantly being exchanged within the system. The Drive Resident Digital MMC Control is designed for use in industrial environments, but some guidelines should be followed.

**Figure 10-2: Recommended EMC Compliant Connections**



Inside a control cabinet, connect the shields of shielded cables. The two different methods of terminating shields are used to accommodate two different immunity requirements. Immunity required inside an enclosure is considered lower because cables are typically less than three meters in length and/or can be separated from each other and from noise sources.

Immunity required external to an enclosure is considered higher because the user may have less control over the noise environment. Low level signal cables that can be external to an enclosure are tested at a 2 KV level for electrical fast transients (EFTs).



Low level signals that can be less than three meters in length or can be separated from noise sources are tested at a 1 KV level. Under the stated conditions, there will be no disturbance of digital I/O, encoder, or encoder operation. For analog signals, there may be momentary disturbances but there will be self-recovery when the noise subsides.

Do not operate transmitters, arc welding equipment, or other high noise radiators within one meter of an enclosure that has the door open. Continue to equip inductive devices, if they are in series with a mechanical contact or switch, with arc suppression circuits. These devices include contactors, solenoids and motors. Shield all cables that carry heavy current near the system, using continuous foil wrap or conduit grounded at both ends. Such cables include power leads for high-frequency welders and for pulse-width-modulated motor drives.

#### WARNING

Use care when wiring I/O devices to the Drive Resident Digital MMC Control and when plugging in cables. Wiring the wrong device to the connector or plugging a connector into the wrong location could cause intermittent or incorrect machine operation.

## 10.4 Starting an Operation

Good procedure suggests that the system should be tested each time a new application is powered up. The Diagnostic LED (D2) on the Drive Resident Digital MMC Control should be off indicating that the diagnostic tests were passed.

Turn off the main disconnect switch and plug the DC connector into the power connector on the MMC-SD. Turn on input power. The D2 LED turns on and then turns off when the Drive Resident Digital MMC Control passes its diagnostic tests.

### 10.4.1 Connecting the Drive Resident Digital MMC Control to the Application

1. Turn off the main disconnect switch in the control cabinet. If some devices are not powered from the control cabinet, turn them off also.
2. Connect the connectors according to your diagrams.
3. Turn on power to the system. The PWR light on the MMC-SD goes on and stays on.  
The D2 light goes on, then goes off in turn.  
The SCAN (S) light goes on.  
The application starts to work under control of the system.
4. If an application program is not in system memory, use the download command in the PiCPro software to place it there.

### 10.4.2 Basic Setup and Maintenance Procedures

[Table 10-1](#) below summarizes how to proceed when performing certain maintenance and/or setup functions.

<b>Table 10-1: Troubleshooting Summary</b>	
<b>In order to:</b>	<b>Do the following:</b>
Turn off the entire application.	Turn off main disconnect (which should also turn off all external power supplies to the application); unplug the DC power to the MMC-SD.
Wire the I/O to the application.	Turn off main disconnect (which should also turn off all external power supplies to the application); unplug the DC power to the MMC-SD.
Change the battery.	Turn off main disconnect (which should also turn off all external power supplies to the application); unplug the DC power to the MMC-SD.
Connect/disconnect the MMC with the computer workstation through the PiCPro port.	Turn off main disconnect (which should also turn off all external power supplies to the application); unplug the DC power to the MMC-SD.
Connect/disconnect the MMC with an operator interface through the User port.	Turn off main disconnect (which should also turn off all external power supplies to the application); unplug the DC power to the MMC-SD.
Download an application program into the memory.	Make sure power is on (check the <b>P</b> LED) on the MMC-SD.
Stop the scan.	From the workstation - use the Stop Scan commands in the PiCPro software.

### 10.4.3 Start-up Diagnostics

When the system is powered up, it tests itself and reports the results in the form of LED signals.

#### 10.4.3.1 Power LED

If the Power LED (P) on MMC-SD does not go on, or goes off during operation of the system, check that power is still connected to the MMC-SD. If the power LED on the MMC-SD is on, turn off the main disconnect switch and replace the Drive Resident Digital MMC Control.

#### 10.4.3.2 Scan LED

If the SCAN (S) LED does not go on:

1. Check that the power (P) light is ON.
2. Check that the diagnostic (D2) light is OFF.

### 10.4.3.3 Drive Resident Digital MMC Control Start-Up Diagnostic LEDs

The LED D2 light on the Drive Resident Digital MMC Control lights up briefly while its diagnostic tests are running and then goes off. If D2 remains on, the Drive Resident Digital MMC Control has failed one of its tests. Follow these steps:

1. Turn off power to the system and to the application.
2. If the I/O wiring is connected, remove the connector.
3. Remove the defective Drive Resident Digital MMC Control from the drive.
4. Replace with a new Drive Resident Digital MMC Control. Connect the I/O wiring.
5. Turn on power to check diagnostics again.

NOTE
Diagnosics are run only when the system is powered up. It is possible that a failure might occur during operation. If so, D2 remains off. If you suspect that a module might be defective, cycle power to run diagnostics again.

#### 10.4.4 MMC Run-Time Diagnostics

While the Drive Resident Digital MMC Control is running, other tests are performed on a regular basis with their results also reported by D2.

While the Drive Resident Digital MMC Control is running, the D2 will flash a three digit code signal if there is an error. For example, if there is a long pause-flash-pause-flash-flash-pause-flash-flash-flash-long pause, the code is 123.

<b>Code</b>	<b>Error</b>	<b>Description</b>
123	Scan too long	A ladder scan loss has occurred because the CPU takes more than 200 ms to scan the application program. Whenever the scan light is out, the discrete outputs go to the OFF state and the analog outputs are zeroed.
124	Excessive overhead	The system overhead update time is excessive.
125	Insufficient memory	There is insufficient memory on the CPU to run the current program.
126	No hardware bit memory	There is no bit memory installed on the CPU and the program requires it.
127	No software bit memory	There is no bit memory capability via software and the program requires it.
222	Driver error	No driver support on the CPU for the I/O module. Update your system EPROMs.
22_	Master rack error	The I/O modules in the master rack do not match what was declared in the hardware master declaration table. The number of flashes in the third digit (__) identifies the slot number that is in error.
232	Communications error	A failure has occurred in remote I/O communications.
3_ _	Expansion rack error	The I/O modules in the block I/O modules do not match what was declared in the expansion hardware declaration table. <b>For block I/O modules:</b> The number of flashes in the second and third digits indicates the block I/O module (01 through 77). The second digit will flash a 1 - 7, 10 for 0. The third digit will flash a 1 - 9, 10 for 0. For example, if the second digit flashes <b>3</b> times and the third digit flashes <b>10</b> times, the module is <b>30</b> .

## 10.5 MMC Connections to External Devices for Machine Control

Danaher Motion provides many optional accessories that simplify wiring the Drive Resident Digital MMC Control to external devices.

These accessories include cables to connect MMC-SD drives together and breakout boxes that provide screw-terminal connections to the Drive Resident Digital MMC Control. Contact Danaher Motion for further information.

### 10.5.1 PiCPro Port (P1)

The PiCPro Port (P1) connector provides serial communication for the PiCPro programming interface. PiCPro Port (P1) is physically located on the MMC-SD faceplate. Refer to Chapter 5 for information on the PiCPro (P1) Port.

Note: PiCPro can also be run over from the Ethernet (C4) connector.

### 10.5.2 Block I/O Port (C1)

**Note:** The Block I/O Port (C1) is not included on the Digital MMC-D1.

The Block I/O Port (C1) is a 9-pin female “D” connector and provides:

- Up to 77 expansion block I/O units
- 4-wire communication interface
- Up to 200 feet between block I/O units

<b>Pin</b>	<b>Description</b>	<b>In/Out</b>
1	NC	
2	NC	
3	Block I/O Transmit Data +	Out
4	Block I/O Transmit Data -	Out
5	Block I/O Receive Data +	In
6	Block I/O Receive Data -	In
7	Shield (see Note below)	
8	NC	
9	NC	

**NOTE**

Pin 7 of the Block I/O Port (C1) connector is connected to the connector shell within the Drive Resident Digital MMC Control. Therefore, the shield may be connected to either pin 7 or the connector shell.

**10.5.3 User Port (C3)**

The User Port (C3) is a 15-pin male high density “D” connector, used to communicate with a touch-screen, a hand-held controller, or other serial interface device. The User Port (C3) provides:

- RS232/RS485 communication
- Baud rates to 115.2 K
- Multidrop capability

**Table 10-4: Pinout for User Port (C3)**

Pin	Description	In/ Out	Pin	Description	In/ Out
1	NC	N/A	9	RS232 Receive Data	In
2	NC	N/A	10	RS232 Transmit Data	Out
3	NC	N/A	11	NC	
4	RS232 Data Terminal Ready (3.3V)	Out	12	RS485 Receive Data +	In
5	RS232 Request to Send	Out	13	RS485 Receive Data -	In
6	NC	N/A	14	RS485 Transmit Data +	Out
7	RS232 Clear to Send	In	15	RS485 Transmit Data -	Out
8	Signal Ground	In/ Out			

**10.5.4 Ethernet Port (C4)**

**NOTE:** The Ethernet Port (C4) is not included on the Digital MMC-D1.

The Ethernet Port (C4) consists of an 8-pin RJ45 connector and LEDs that provide:

- IEEE 802.3/802.3u-100Base-TX/10Base T, half duplex connectivity
- A green “Link” LED. This LED will be on if there is either a 100Base-T or 10Base-T Link.

- A green “Activity” LED. This LED will be on whenever a send or receive packet has occurred.

Communication using the Ethernet Port can be between the Drive Resident Digital MMC Control and a PC, User Interface, or other Ethernet device or network. For example, PiCPro running on a PC can communicate to the MMC Smart Drive through this Ethernet connector.

<b>Pin</b>	<b>Description</b>	<b>In/Out</b>
1	Transmit Data + (TD+)	Out
2	Transmit Data - (TD-)	Out
3	Receive Data + (RD+)	In
6	Receive Data - (RD-)	In
4,5,7,8	Termination Resistors (See Note 1, below)	In
Shell	Chassis Ground	In

**Note 1:** Pins 4, 5, 7, and 8 are tied to termination resistors on the Drive Resident Digital MMC Control. Standard Ethernet cables contain 8 wires. The Drive Resident Digital MMC Control only uses 4 of these wires as shown. Connecting the 4 unused wires to the Drive Resident Digital MMC Control pins 4, 5, 7, and 8, (as will be done in a standard Ethernet cable) reduces noise that can be induced from the unused wires to the Transmit and Receive wires.

Typically, a “straight-through” cable should be used when connecting the Drive Resident Digital MMC Control to another Ethernet device. Refer to [Figure 11.5 on page 185](#) for cables available from Danaher Motion.

### 10.5.5 General I/O Port (C5)

The General I/O Port (C5) is a 26-pin male high density “D” connector and includes:

- 8-24 VDC sourcing inputs (Input 1 can trigger an interrupt on the rising or falling edge)
- +24 VDC and 24 V Common
- 8-24 VDC outputs
  - Source only
  - 250 mA output capacity
  - Short circuit protection

**Table 10-6: Pinout for General I/O Port (C5)**

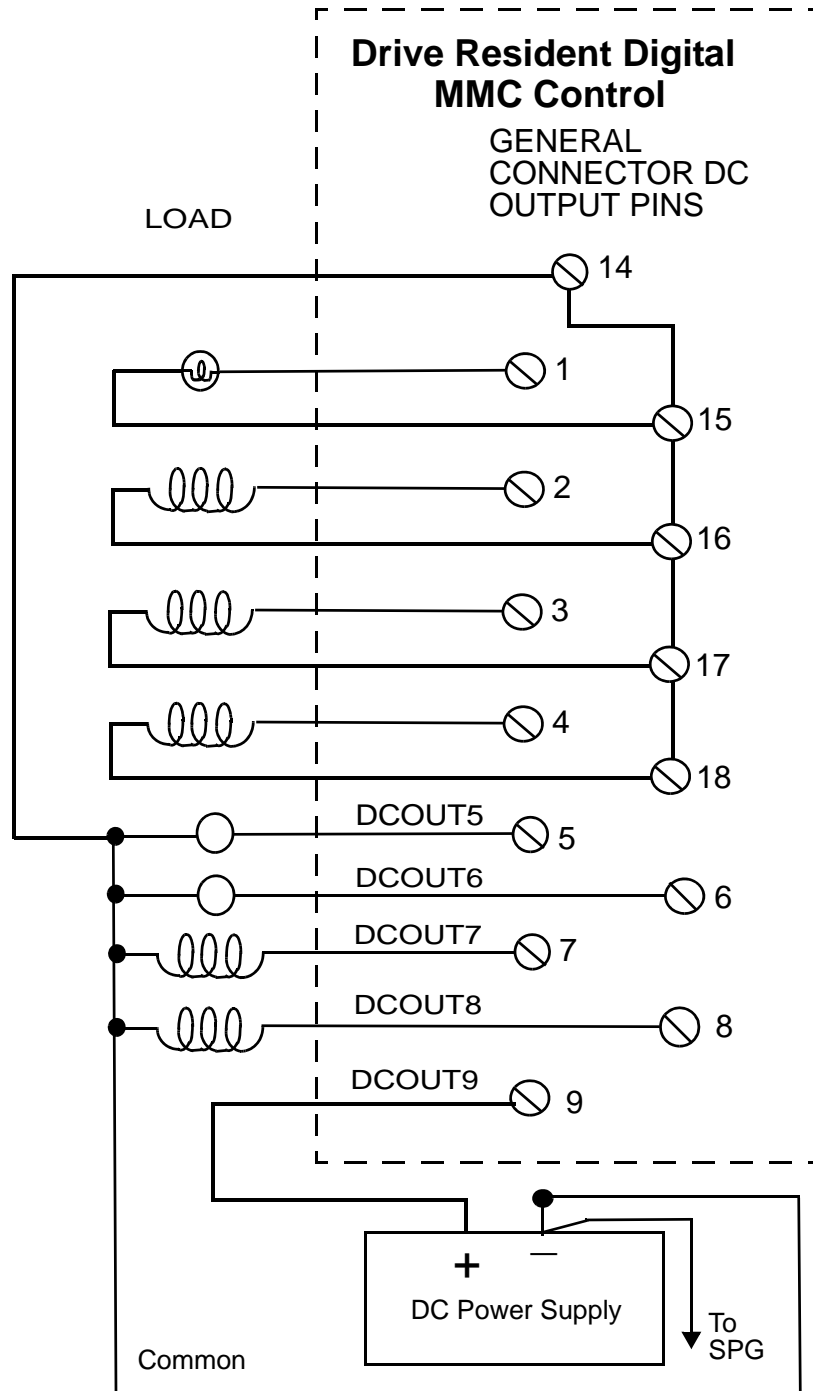
Pin	Description	In/Out	Pin	Description	In/Out
1	DCOUT1 <sup>a</sup>	Out	16	IO24C <sup>c</sup>	In/Out
2	DCOUT2 <sup>a</sup>	Out	17	IO24C <sup>c</sup>	In/Out
3	DCOUT3 <sup>a</sup>	Out	18	IO24C <sup>c</sup>	In/Out
4	DCOUT4 <sup>a</sup>	Out	19	DCIN1	In
5	DCOUT5 <sup>a</sup>	Out	20	DCIN2	In
6	DCOUT6 <sup>a</sup>	Out	21	DCIN3	In
7	DCOUT7 <sup>a</sup>	Out	22	DCIN4	In
8	DCOUT8 <sup>a</sup>	Out	23	DCIN5	In
9	24VDC OUT POWER <sup>a</sup>	In	24	DCIN6	In
10	IO24V <sup>b</sup>	In/Out	25	DCIN7	In
11	IO24V <sup>b</sup>	In/Out	26	DCIN8	In
12	IO24V <sup>b</sup>	In/Out			
13	IO24V <sup>b</sup>	In/Out			
14	IO24C <sup>c</sup>	In/Out			
15	IO24C <sup>c</sup>	In/Out			

- a. Pin 9 is 24VDC into the Drive Resident Digital MMC Control to power the 8 outputs
- b. Pins 10-13 are only connected to each other within the Drive Resident Digital MMC Control. If used, tie one pin to 24VDC, and the other to one side of input devices
- c. Pins 14-18 are connected together within the Drive Resident Digital MMC Control. Connect pin 14 to 24V common. This provides the return path for the 24VDC inputs, and allows pin 15-18 to be connected to one side of output devices if desired.



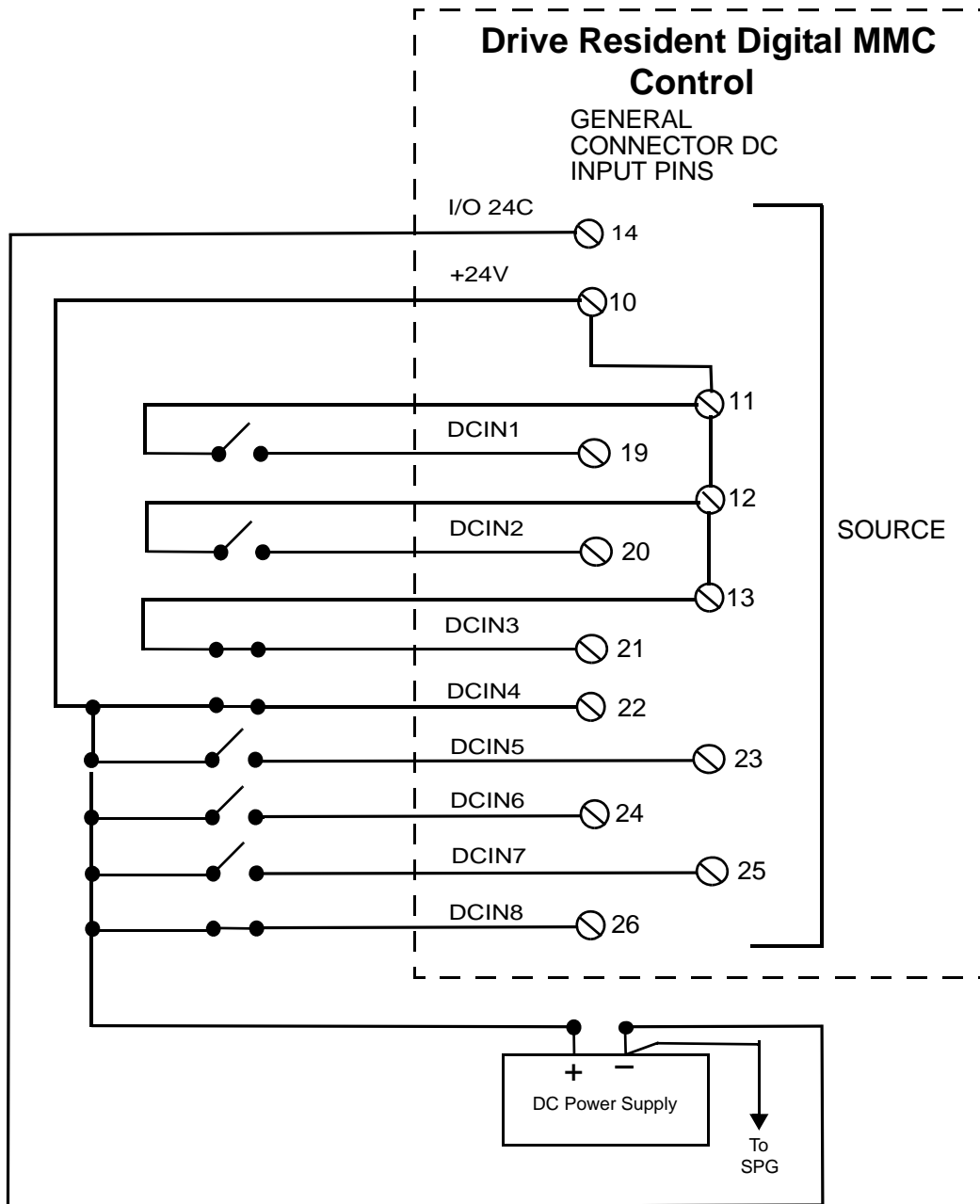
There are 8 DC outputs on the General I/O Port (C5). These outputs get their power from Pin 9 of the Drive Resident Digital MMC Control as shown in [Figure 10-3](#).

**Figure 10-3: General Outputs for General I/O Port (C5) Connected to Loads**



There are 8 general inputs on the General I/O Port (C5). The inputs are configured as sourcing as shown in Figure 10-4.

Figure 10-4: Source General Input Configuration for General I/O Port (C5)



10.6 Specifications

General											
Characteristic		MMC Specifications									
								Number of servo axes available at six update rates <sup>a</sup>			
Model	Part No.	Speed	App Mem	RAM Mem	User Mem	8 ms	4 ms	2 ms	1 ms	.5 ms	.25 ms
Digital MMC-D1	M.3000 .0164	Std.	384K	256K	64K	1	1	1	1	1	1
Digital MMC-D2	M.3000 .0165	Std.	384K	256K	64K	2	2	2	2	2	1
Digital MMC-D4	M.3000 .0166	Std.	384K	256K	64K	4	4	4	4	2	1
Digital MMC-D8	M.3000 .0518	X1.5	384K	256K	64K	8	8	8	4-8	2-4	1-2
Digital MMC-D16	M.3000 .0167	X1.5	384K	256K	64K	16	16	8-16	4-8	2-4	1-2

a. Using features such as servo tasks, S-curve, RATIO\_RL, M\_LINCIR, M\_SCRVLC, PLS, and CAM\_OUT places a heavier burden on available CPU time. Consult Danaher Motion for assistance if you want to exceed the number of axes in this chart.

<b>CPU</b>	<b>32 bit RISC processor with numeric coprocessor</b>
<b>Battery</b>	<b>3V Coin Cell, BR2032 lithium battery</b>
<b>CAUTION for Lithium Batteries</b> Danger of explosion if battery is incorrectly replaced. Replace only with the same or equivalent type recommended by the manufacturer. Dispose of used batteries according to the manufacturer's instructions.	
Flash Disk	2 Megabytes
Memory	1 Megabyte max.
PiCPro Port (to workstation)	RS232 serial port, secured protocol Software selectable baud rate to 115.2K
User Port (to serial interface device)	RS232/RS485 serial port Supports RTS/CTS hardware handshaking Software selectable baud rate to 115.2K
Ethernet Port (to Ethernet Device)	IEEE 802.3/802.3u-100Base-TX/10Base T Half duplex Cable type: Shielded, Straight Pinned, CAT5 or better (CAT5e, CAT6, etc.) Maximum cable length: 82.5 ft (25 m)
Input voltage from MMC-SD Drive	20 VDC to 30 VDC

Input power from MMC-SD Drive	250 mA
Time-of-day clock Clock tolerance	Access via PiCPro 10.2 and above or your application program At 25°C (77°F), ±1 second per day Over temperature, voltage and aging variation, +2/-12 seconds per day
<b>General DC Inputs</b>	
Configuration	Sourcing only. Operates with IEC Type 1 inputs (per IEC 1131-2)
Input voltage	Nominal 24 VDC, maximum 30 VDC
Guaranteed on voltage	15 VDC
Guaranteed off voltage	5 VDC
Turn on/off time	1 ms
<b>General DC Outputs</b>	
Number of outputs	8 outputs
Input voltage	Nominal 24 VDC, 30 VDC maximum
Configuration	Eight solid-state switches.
Protection of logic circuits	Optical isolation between the logic and field side, transient suppression on the 24V external supply
Maximum current	.25 A per output
Voltage range	24 VDC nominal, 5 to 30 VDC
Switch characteristics	Solid-state switches
Time delay on for resistive loads	50 µsec max
Time delay off for resistive loads	50 µsec max
Leakage current in off state	0.5 mA max
Switch voltage, maximum ON	1 VDC max
Short circuit protection for each group	15 A (max) pulses for about 130 µsec every 100 msec until short is removed
Scan loss response	Outputs turn off

## 11 Part Numbers

### 11.1 230V Smart Drives

DESCRIPTION	MODEL NUMBER	PART NUMBER
<b>2.5A Cont. / 7.5A Max./ .5kW</b>		
Analog, standard width	MMC-SD-0.5-230	M.1302.5090
Digital, standard width without BiSS	MMC-SD-0.5-230-D	M.1302.8130
Digital, standard width with BiSS	MMC-SD-0.5-230-D	M.3000.0461
Digital, narrow width without BiSS	MMC-SD-0.5-230-DN	M.1302.8908
Digital, narrow width with Biss	MMC-SD-0.5-230-DN	M.3000.0458
<b>5A Cont. / 15A Max./ 1kW</b>		
Analog, standard width	MMC-SD- 1.0-230	M.1302.5091
Digital, standard width without BiSS	MMC-SD-1.0-230-D	M.1302.8131
Digital, standard width with BiSS	MMC-SD-1.0-230-D	M.3000.0462
Digital, narrow width without BiSS	MMC-SD-1.0-230-DN	M.1302.8910
Digital, narrow width with Biss	MMC-SD-1.0-230-DN	M.3000.0459
<b>10A Cont. / 30A Max / 2kW</b>		
Analog, standard width	MMC-SD-2.0-230	M.1302.5092
Digital, standard width without BiSS	MMC-SD-2.0-230-D	M.1302.8132
Digital, standard width with BiSS	MMC-SD-2.0-230-D	M.3000.0463
Digital, narrow width without BiSS	MMC-SD-2.0-230-DN	M.1302.8911
Digital, narrow width with Biss	MMC-SD-2.0-230-DN	M.3000.0460

## 11.2 460V Smart Drives

DESCRIPTION	MODEL NUMBER	PART NUMBER
<b>3.0A Cont. / 6.0A Max. / 1.3 kW</b>		
Analog	MMC-SD-1.3-460	M.1302.5093
Digital, without BiSS	MMC-SD-1.3-460-D	M.1302.8133
Digital, with BiSS	MMC-SD-0.5-230-D	M.3000.0464
<b>5.5A Cont. / 11.0A Max. / 2.4 kW</b>		
Analog	MMC-SD-2.4-460	M.1302.5094
Digital, without BiSS	MMC-SD-2.4-460-D	M.1302.8134
Digital, with BiSS	MMC-SD-2.4-460-D	M.3000.0465
<b>9.0A Cont. / 18.0A Max. / 4.0 kW</b>		
Analog	MMC-SD-4.0-460	M.1302.5095
Digital, without BiSS	MMC-SD-4.0-460-D	M.1302.8135
Digital, with BiSS	MMC-SD-4.0-460-D	M.3000.0466
<b>13.5A Cont. / 27.0A Max. / 6.0 kW</b>		
Analog	MMC-SD-6.0-460	M.1302.5096
Digital, without BiSS	MMC-SD-6.0-460-D	M.1302.8136
Digital, with BiSS	MMC-SD-6.0-460-D	M.3000.0467
<b>18.0A Cont. / 36.0A Max. / 8.0 kW</b>		
Analog	MMC-SD-8.0-460	M.1302.5097
Digital, without BiSS	MMC-SD-8.0-460-D	M.1302.8137
Digital, with BiSS	MMC-SD-8.0-460-D	M.3000.0468
<b>27.5A Cont. / 55.0A Max. / 12.0 kW</b>		
Analog	MMC-SD-12.0-460	M.1302.5098
Digital, without BiSS	MMC-SD-12.0-460-D	M.1302.8138
Digital, with BiSS	MMC-SD-12.0-460-D	M.3000.0469

DESCRIPTION	MODEL NUMBER	PART NUMBER
<b>36.5A Cont. / 73.0A Max. / 16.0 kW</b>		
Analog	MMC-SD-16.0-460	M.1302.5099
Digital, without BiSS	MMC-SD-16.0-460-D	M.1302.8139
Digital, with BiSS	MMC-SD-16.0-460-D	M.3000.0470
<b>55.0A Cont. / 110.0A Max. / 24.0 kW</b>		
Analog	MMC-SD-24.0-460	M.1302.5100
Digital, without BiSS	MMC-SD-24.0-460-D	M.1302.8140
Digital, with BiSS	MMC-SD-24.0-460-D	M.3000.0471
<b>69.3A Cont. / 110.0A Max. / 30.0 kW</b>		
Digital, with BiSS	MMC-SD-30.0-460-D	M.3000.0021
<b>93.3A Cont. / 147.0A Max. / 42.0 kW</b>		
Digital, with BiSS	MMC-SD-42.0-460-D	M.3000.0022
<b>117.4A Cont. / 189.0A Max. / 51.0 kW</b>		
Digital, with BiSS	MMC-SD-51.0-460-D	M.3000.0023
<b>152.7A Cont. / 209.0A Max. / 65.0 kW</b>		
Digital, with BiSS	MMC-SD-65.0-460-D	M.3000.0024

**11.3 Option Modules****11.3.1 Resolver Interface Option Module**

<b>Module</b>	<b>Model Number</b>	<b>Part Number</b>
Resolver Interface Option Module		M.1302.4523

**11.3.2 Drive Resident Digital MMC Control**

<b>Drive Resident Digital MMC Control</b>	<b>Model Number</b>	<b>Part Number</b>
1 Axis Controller	Digital MMC-D1	M.3000.0164
2 Axis Controller	Digital MMC-D2	M.3000.0165
4 Axis Controller	Digital MMC-D4	M.3000.0166
8 Axis Controller	Digital MMC-D8	M.3000.0518
16 Axis Controller	Digital MMC-D16	M.3000.0167



**11.4 Direct Connect Cables**

**11.4.1 Drive Programming Cable**

Description	Drive Connector	Part Number
PiCPro Port to PC Connector (Analog)	P1	M.1302.8250
PiCPro Port to PC Connector (Digital)		M.1302.8284

**11.4.2 Standalone MMC to MMC Smart Drive I/O Cable**

Description	Drive Connector	Part Number
MMC A'n' to MMC Smart Drive I/O 0.5M	IO	M.1302.5990
MMC A'n' to MMC Smart Drive I/O 1.0M		M.1302.5991
MMC A'n' to MMC Smart Drive I/O 1.5M		M.1302.5992
MMC A'n' to MMC Smart Drive I/O 3.0M		M.1302.5993

**11.5 Digital Link and Networking Cables**

Description	Drive Connector	MMC-SD Control Connector	Part Number
CAT5e Patch Cord 0.3M	IN, OUT	C4	M.1302.8285
CAT5e Patch Cord 0.6M			M.1302.8286
CAT5e Patch Cord 1.0M			M.1302.8287
CAT5e Patch Cord 2.0M			M.1302.8288
CAT5e Patch Cord 3.0M			M.1302.8289
CAT5e Patch Cord 5.0M			M.1302.8300
CAT5e Patch Cord 10M			M.1302.8301
CAT5e Patch Cord 15M			M.1302.8302
CAT5e Patch Cord 30M			M.1302.8303

**11.6 Connector Kits**

<b>Description</b>	<b>Part Number</b>
CONN-FBK-12POS-16-28AWG	M.1302.0500
CONN-FBK-17POS-16-28AWG	M.1302.0510
CONN-PWR-BRK-8POS-14-16AWG-SIZE 1	M.1302.0479
CONN-PWR-BRK-8POS-12AWG-SIZE 1	M.1302.8755
CONN-PWR-BRK-8POS-12-14AWG-SIZE 1.5	M.1302.1998
CONN-PWR-BRK-8POS-8-10AWG-SIZE 1.5	M.1302.2354
CONN-PWR-BRK-8POS-6AWG-SIZE 3	M.1302.7492
CONN-PWR-BRK-8POS-4AWG-SIZE 3	M.1302.7493
CONN-PWR-FAN-6POS-16AWG	M.1302.6219
CONN-X100-X101	M.1302.7099
CONN-4TERM-MAINS	M.1302.7158
CONN-4TERM-MOTOR	M.1302.7159

**11.7 Breakout Boards and Cables****11.7.1 Drive Mounted Breakout Boards**

Description	Drive Connector	Part Number
BKOUT BD, F1/F2 MMC-SD, DR MT	F1, F2	M.1302.6970
BKOUT BD, I/O MMC-SD, DR MT	IO	M.1302.6971
BKOUT BD, C5 MMC-SD, DR MT	C5	M.1302.8480

**11.7.2 Panel Mounted Breakout Boards**

Description	Drive Connector	MMC-SD Control Connector	Part Number
BKOUT BD, F1/F2 MMC-SD, PNL MT	F1, F2		M.1302.6972
BKOUT BD, DRIVE I/O MMC-SD, PNL MT	IO		M.1302.6973
BKOUT BD, GEN I/O MMC-SD CONTROL, PNL MT		C5	M.1302.8253
BKOUT BD, BLOCK I/O MMC-SD CONTROL, PNL MT		C1	M.1016.2533
BKOUT BD, USER SERIAL MMC-SD CONTROL, PNL MT		C3	M.1016.2530

**11.7.3 Breakout Board Kits**

Description	Drive Connector	Part Number
KIT, BKOUT BD, F1/F2 MMC-SD 1.0M	F1, F2	M.1302.7005
KIT, BKOUT BD, F1/F2 MMC-SD 3.0M		M.1302.7006
KIT, BKOUT BD, F1/F2 MMC-SD 9.0M		M.1302.7007
KIT, BKOUT BD, F1/F2 MMC-SD 15.0M		M.1302.7008
KIT, BKOUT BD, I/O MMC-SD 1.0M	IO	M.1302.7009
KIT, BKOUT BD, I/O MMC-SD 3.0M		M.1302.7030
KIT, BKOUT BD, I/O MMC-SD 9.0M		M.1302.7031

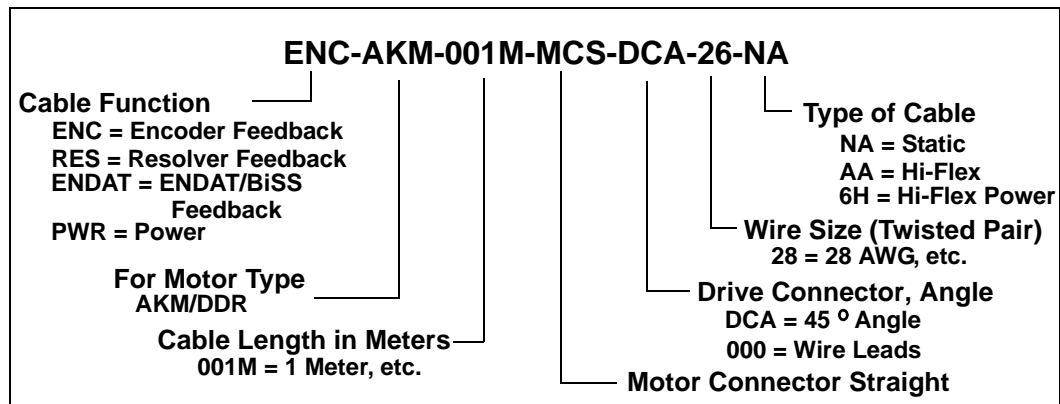
## 11.7.4 Breakout Board Cables

Description	Drive Connector	MMC-SD Control Connector	Part Number
CABLE, MMC-SD Feedback Port to Breakout Board, 1 Meter	F1, F2		M.1302.6976
CABLE, MMC-SD Feedback Port to Breakout Board, 3 Meter			M.1302.6977
CABLE, MMC-SD Feedback Port to Breakout Board, 9 Meter			M.1302.6979
CABLE, MMC-SD Feedback Port to Breakout Board, 15 Meter			M.1302.6980
CABLE, MMC-SD Drive I/O Port to Breakout Board, 1 Meter	IO		M.1302.6982
CABLE, MMC-SD Drive I/O Port to Breakout Board, 3 Meter			M.1302.6984
CABLE, MMC-SD Drive I/O Port to Breakout Board, 9 Meter			M.1302.6985
CABLE, MMC Control General I/O Port to Breakout Board, 1 Meter		C5	M.1302.8254
CABLE, MMC Control General I/O Port to Breakout Board, 3 Meter			M.1302.8255
CABLE, MMC Control General I/O Port to Breakout Board, 9 Meter			M.1302.8256
CABLE, MMC Control User Serial Port to Breakout Board, 1 Foot		C3	M.1016.2715
CABLE, MMC Control User Serial Port to Breakout Board, 2 Foot			M.1016.2716
CABLE, MMC Control User Serial Port to Breakout Board, 3 Foot			M.1016.2717
CABLE, MMC Control Block I/O Port to Breakout Board, 1 Foot		C1	M.1016.2543
CABLE, MMC Control Block I/O Port to Breakout Board, 2 Foot			M.1016.2544
CABLE, MMC Control Block I/O Port to Breakout Board, 3 Foot			M.1016.2545

## 11.7.5 Flying Lead Cables

Description	Drive Connector	MMC-SD Control Connector	Part Number
CABLE, MMC-SD Drive Feedback Port to Flying Lead, 10 Feet	F1, F2		M.1016.2519
CABLE, MMC-SD Drive I/O Port to Flying Lead, 1 Meter	IO		M.1302.7032
CABLE, MMC-SD Drive I/O Port to Flying Lead, 3 Meter			M.1302.7034
CABLE, MMC-SD Drive I/O Port to Flying Lead, 9 Meter			M.1302.7035
CABLE, MMC-SD Drive I/O Port to Flying Lead, 15 Meter			M.1302.7036
CABLE, MMC-SD Drive I/O Port to Flying Lead, 30 Meter			M.1302.7037
CABLE, MMC-SD Control General I/O Port to Flying Lead, 1 Meter			
CABLE, MMC-SD Control General I/O Port to Flying Lead, 3 Meter	M.1302.8258		
CABLE, MMC-SD Control General I/O Port to Flying Lead, 9 Meter	M.1302.8259		
CABLE, MMC-SD Control General I/O Port to Flying Lead, 15 Meter	M.1302.8290		
CABLE, MMC-SD Control General I/O Port to Flying Lead, 30 Meter	M.1302.8291		
CABLE, MMC-SD Control User Serial Port to Flying Lead, 10 Feet		C3	M.1016.2568
CABLE, MMC-SD Control Block I/O Port to Flying Lead, 10 Feet		C1	M.1016.2565

## 11.8 Motor Cables (AKM/DDR Motors)



### 11.8.1 Feedback Cables (AKM/DDR Motors)

Feedback Cable	Part Number
<b>Static Type</b>	
ENC-AKM-001M-MCS-DCA-28-NA	M.1302.8590
ENC-AKM-003M-MCS-DCA-28-NA	M.1302.8447
ENC-AKM-006M-MCS-DCA-28-NA	M.1302.8591
ENC-AKM-009M-MCS-DCA-28-NA	M.1302.8542
ENC-AKM-015M-MCS-DCA-28-NA	M.1302.8594
ENC-AKM-030M-MCS-DCA-28-NA	M.1302.8595
RES-AKM-001M-MCS-DCA-28-NA	M.1302.8618
RES-AKM-003M-MCS-DCA-28-NA	M.1302.8439
RES-AKM-006M-MCS-DCA-28-NA	M.1302.8619
RES-AKM-009M-MCS-DCA-28-NA	M.1302.8620
RES-AKM-015M-MCS-DCA-28-NA	M.1302.8621
RES-AKM-030M-MCS-DCA-28-NA	M.1302.8622
ENDAT-AKM-001M-MCS-DCA-28-NA	M.1302.8605
ENDAT-AKM-003M-MCS-DCA-28-NA	M.1302.8437
ENDAT-AKM-006M-MCS-DCA-28-NA	M.1302.8606
ENDAT-AKM-009M-MCS-DCA-28-NA	M.1302.8607

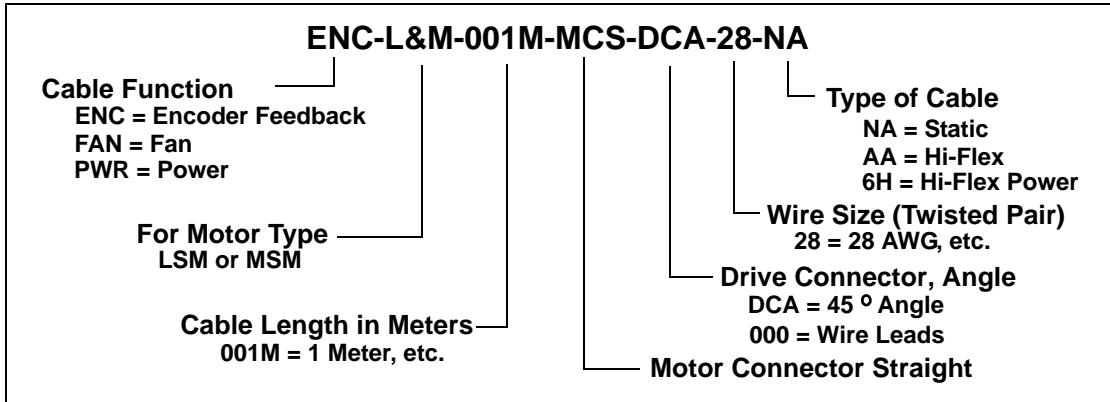
ENDAT-AKM-015M-MCS-DCA-28-NA	M.1302.8608
ENDAT-AKM-030M-MCS-DCA-28-NA	M.1302.8609
<b>Flexing Type (12 X O.D. Min Bend Radius)</b>	
ENC-AKM-001M-MCS-DCA-28-AA	M.1302.8600
ENC-AKM-003M-MCS-DCA-28-AA	M.1302.8435
ENC-AKM-006M-MCS-DCA-28-AA	M.1302.8601
ENC-AKM-009M-MCS-DCA-28-AA	M.1302.8602
ENC-AKM-015M-MCS-DCA-28-NA	M.1302.8603
ENC-AKM-030M-MCS-DCA-28-NA	M.1302.8604
RES-AKM-001M-MCS-DCA-28-NA	M.1302.8630
RES-AKM-003M-MCS-DCA-28-NA	M.1302.8450
RES-AKM-006M-MCS-DCA-28-NA	M.1302.8631
RES-AKM-009M-MCS-DCA-28-NA	M.1302.8632
RES-AKM-015M-MCS-DCA-28-NA	M.1302.8633
RES-AKM-030M-MCS-DCA-28-NA	M.1302.8634
ENDAT-AKM-001M-MCS-DCA-28-NA	M.1302.8613
ENDAT-AKM-003M-MCS-DCA-28-NA	M.1302.8438
ENDAT-AKM-006M-MCS-DCA-28-NA	M.1302.8614
ENDAT-AKM-009M-MCS-DCA-28-NA	M.1302.8615
ENDAT-AKM-015M-MCS-DCA-28-NA	M.1302.8616
ENDAT-AKM-030M-MCS-DCA-28-NA	M.1302.8617

**11.8.2 Motor Power Cables (AKM/DDR Motors)**

<b>Power Cable (Flexing Type, 12 X O.D. Min Bend Radius)</b>	<b>Part Number</b>
PWR-AKM-001M-MCS-000-14-6H	M.1302.8585
PWR-AKM-003M-MCS-000-14-6H	M.1302.8549
PWR-AKM-006M-MCS-000-14-6H	M.1302.8586
PWR-AKM-009M-MCS-000-14-6H	M.1302.8554
PWR-AKM-015M-MCS-000-14-6H	M.1302.8588
PWR-AKM-030M-MCS-000-14-6H	M.1302.8589



11.9 Motor Cables (LSM/MSM Motors)



11.9.1 Feedback Cables (LSM/MSM Motors)

Feedback Cable	Part Number
<b>Static Type</b>	
ENC-L&M-001M-MCS-DCA-28-NA	M.1302.0944
ENC-L&M-003M-MCS-DCA-28-NA	M.1302.0945
ENC-L&M-009M-MCS-DCA-28-NA	M.1302.0946
ENC-L&M-015M-MCS-DCA-28-NA	M.1302.0947
ENC-L&M-030M-MCS-DCA-28-NA	M.1302.0948
<b>Flexing Type (12 X O.D. Min Bend Radius)</b>	
ENC-L&M-001M-MCS-DCA-28-AA	M.1302.5834
ENC-L&M-003M-MCS-DCA-28-AA	M.1302.5835
ENC-L&M-009M-MCS-DCA-28-AA	M.1302.5836
ENC-L&M-015M-MCS-DCA-28-AA	M.1302.5837
ENC-L&M-030M-MCS-DCA-28-AA	M.1302.5838

**11.9.2 Power Cables for Blower Fan (LSM/MSM Motors)**

<b>Power Cable</b>	<b>Part Number</b>
FAN-L&M-001M-MCS-000-16	M.1302.6310
FAN-L&M-003M-MCS-000-16	M.1302.6311
FAN-L&M-009M-MCS-000-16	M.1302.6312
FAN-L&M-015M-MCS-000-16	M.1302.6313
FAN-L&M-030M-MCS-000-16	M.1302.6314

**11.9.3 Motor Power Cables (LSM/MSM Motors)**

<b>Power Cable (Flexing Type, 12 X O.D. Min Bend Radius)</b>	<b>Part Number</b>
PWR-L&M-001M-MCS-000-16-6H	M.1302.1114
PWR-L&M-003M-MCS-000-16-6H	M.1302.1115
PWR-L&M-009M-MCS-000-16-6H	M.1302.1116
PWR-L&M-015M-MCS-000-16-6H	M.1302.1117
PWR-L&M-030M-MCS-000-16-6H	M.1302.1118
PWR-L&M-001M-MCS-000-14-6H	M.1302.1119
PWR-L&M-003M-MCS-000-14-6H	M.1302.1130
PWR-L&M-009M-MCS-000-14-6H	M.1302.1131
PWR-L&M-015M-MCS-000-14-6H	M.1302.1132
PWR-L&M-030M-MCS-000-14-6H	M.1302.1133
PWR-L&M-001M-MCS-000-12-6H	M.1302.1134
PWR-L&M-003M-MCS-000-12-6H	M.1302.1135
PWR-L&M-009M-MCS-000-12-6H	M.1302.1136
PWR-L&M-015M-MCS-000-12-6H	M.1302.1137
PWR-L&M-030M-MCS-000-12-6H	M.1302.1139
PWR-L&M-001M-MCS-000-10-6H	M.1302.1140
PWR-L&M-003M-MCS-000-10-6H	M.1302.1142
PWR-L&M-009M-MCS-000-10-6H	M.1302.1143
PWR-L&M-015M-MCS-000-10-6H	M.1302.1144
PWR-L&M-030M-MCS-000-10-6H	M.1302.1145

PWR-L&M-001M-MCS-000-08-6H	M.1302.1146
PWR-L&M-003M-MCS-000-08-6H	M.1302.1147
PWR-L&M-009M-MCS-000-08-6H	M.1302.1148
PWR-L&M-015M-MCS-000-08-6H	M.1302.1149
PWR-L&M-030M-MCS-000-08-6H	M.1302.1150
PWR-L&M-001M-MCS-000-06-6H	M.3000.tbd
PWR-L&M-003M-MCS-000-06-6H	M.3000.tbd
PWR-L&M-009M-MCS-000-06-6H	M.3000.tbd
PWR-L&M-015M-MCS-000-06-6H	M.3000.tbd
PWR-L&M-030M-MCS-000-06-6H	M.3000.tbd
PWR-L&M-001M-MCS-000-04-6H	M.3000.tbd
PWR-L&M-003M-MCS-000-04-6H	M.3000.tbd
PWR-L&M-009M-MCS-000-04-6H	M.3000.tbd
PWR-L&M-015M-MCS-000-04-6H	M.3000.tbd
PWR-L&M-030M-MCS-000-04-6H	M.3000.tbd
PWR-L&M-001M-MCS-000-02-6H	M.3000.tbd
PWR-L&M-003M-MCS-000-02-6H	M.3000.tbd
PWR-L&M-009M-MCS-000-02-6H	M.3000.tbd
PWR-L&M-015M-MCS-000-02-6H	M.3000.tbd
PWR-L&M-030M-MCS-000-02-6H	M.3000.tbd

**11.10 Optional External Devices****11.10.1 AC Line Filters**

For Drive Model	AC Line Filter Description	Part Number
MMC-SD-0.5-230(-D) MMC-SD-1.0-230(-D)	6A, 250V, Single phase	M.1015.6922
MMC-SD-2.0-230(-D)	10A, 250V, Single phase,	M.1015.6917
MMC-SD-1.3-460(-D) MMC-SD-2.4-460(-D)	7A, 480V, Three phase	M.1302.5241
MMC-SD- 4.0-460(-D) MMC-SD-6.0-460(-D) MMC-SD- 8.0-460(-D)	16A, 480V, Three phase	M.1302.5244
MMC-SD-12.0-460(-D) MMC-SD-16.0-460(-D)	30A, 480V, Three phase	M.1302.5245
MMC-SD-24.0-460(-D)	42A, 480V, Three phase	M.1302.5246
MMC-SD-30.0-460-D MMC-SD-42.0-460-D	56A, 480V, Three phase	M.1302.5247
MMC-SD-51.0-460-D	75A, 480V, Three phase	M.1302.5248
MMC-SD-65.0-460-D	100A, 480V, Three phase	M.3000.0019

**11.10.2 AC Line Reactors**

Drive Model	Required Line Reactor (Amps)	Power Loss (Watts)	Inductance (mH)	Weight (Pounds)	Part Number
MMC-SD-12.0-460(-D)	25	52	1.2	14	M.1302.7373
MMC-SD-16.0-460(-D)	35	54	0.8	16	M.1302.7374
MMC-SD-24.0-460(-D)	45	62	0.7	28	M.1302.7375
MMC-SD-30.0-460-D	55	67	0.5	27	M.3000.0105
MMC-SD-42.0-460-D	80	86	0.4	51	M.3000.0106
MMC-SD-51.0-460-D	100	84	0.3	51	M.3000.0107
MMC-SD-65.0-460-D	130	180	0.2	57	M.3000.0108

**11.10.3 External Shunt Resistor Kits**

For Drive	Shunt Resistor Module	Part Number
MMC-SD-0.5-230(-D) MMC-SD-1.0-230(-D) MMC-SD-2.0-230(-D)	100Ω, 300W, 600V, Dynamic	M.1015.7046
MMC-SD-1.3-460(-D) MMC-SD-2.4-460(-D)	130Ω, 450W Cont. Power, 5.4kW Peak Power, 820V, 240 sec. Time Constant, 121 mm x 93 mm x 605 mm	M.1302.7048
MMC-SD-4.0-460(-D)	95Ω, 700W Cont. Power, 8kW Peak Power, 820V, 250 sec. Time Constant, 121 mm x 93 mm x 705 mm	M.1302.7049
MMC-SD-6.0-460(-D) MMC-SD-8.0-460(-D)	50Ω, 1400W Cont. Power, 17kW Peak Power, 850V, 250 sec. Time Constant, 130 mm x 182 mm x 710 mm	M.1302.7060
MMC-SD-12.0-460(-D) MMC-SD-16.0-460(-D)	25Ω, 2800 W Cont. Power, 32kW Peak Power, 850V, 60 sec. Time Constant, 71 mm x 430 mm x 550 mm	M.1302.7061
MMC-SD-24.0-460(-D) MMC-SD-30.0-460-D MMC-SD-42.0-460-D MMC-SD-51.0-460-D MMC-SD-65.0-460-D	18Ω, 3900W Cont. Power, 70kW Peak Power, 850V, 70 sec. Time Constant, 180 mm x 445 mm x 490 mm	M.1302.7063

**11.11 Software**

Description	Part Number
PiCPro Professional Edition	M.1300.7213
PiCPro MMC Limited Edition	M.1300.7214
PiCPro Monitor Edition	M.1300.7215



12 Declarations of Conformity

EC DECLARATION OF CONFORMITY

The undersigned, representing the supplier

**G & L Motion Control Inc.  
672 South Military Road  
Fond du Lac, Wisconsin 54936-1960**

herewith declares that all **three-phase current synchronous motors, type LSM** are in conformity with the provisions of the following EC Directive when installed in accordance with the installation instructions contained in the product documentation:

*Low Voltage Directive 73/23 EWG*

Conformity of the specified product with the guidelines of this directive will be proved by the total compliance with the following harmonic European standards:

- EN 60034-1: September 2000      Rotating Electrical Machines*
- +A11 May 2002*
- EN 60034-5: December 2001*
- EN 60034-9: June 1998*

Year of Marking: 2002

<i>Signature</i>	<i>Robert J. Kollmeyer</i>
<i>Full Name</i>	Robert J. Kollmeyer
<i>Position</i>	Director of Engineering
<i>Place</i>	G & L Motion Control Inc.
<i>Date</i>	<i>05 - APR - 05</i>

**EC DECLARATION OF CONFORMITY**

The undersigned, representing the supplier

**G & L Motion Control Inc.  
672 South Military Road  
Fond du Lac, Wisconsin 54936-1960**

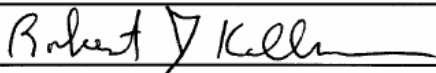
herewith declares that all **three-phase current synchronous motors, type MSM** are in conformity with the provisions of the following EC Directive when installed in accordance with the installation instructions contained in the product documentation:

*Low Voltage Directive 73/23 EWG*

Conformity of the specified product with the guidelines of this directive will be proved by the total compliance with the following harmonic European standards:

*EN 60034-1: November 1995      Rotating Electrical Machines*  
*EN 60034-5: April 1998*  
*EN 60034-9: May 1996*

Year of Marking: 1999

<i>Signature</i>	
<i>Full Name</i>	Robert J. Kollmeyer
<i>Position</i>	Director of Engineering
<i>Place</i>	G & L Motion Control Inc.
<i>Date</i>	05 - APR - 05



The undersigned, representing the supplier

**G & L Motion Control Inc.**  
**672 South Military Road**  
**Fond du Lac, Wisconsin 54936-1960**

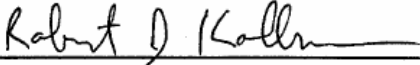
herewith declares that all **PiC900™/PiC90™/PiC9™/MMC and Block I/O modules**, labeled with the CE mark, are in conformity with the provisions of the following EC Directives when installed in accordance with the installation instructions contained in the product documentation:

*Low Voltage Directive 73/23/EEC as amended by 93/68/EEC*  
*EMC Directive 89/336/EEC as amended by 92/31/EEC and 93/68/EEC*

Conformity of the specified product is based upon application of the following standards and/or technical specifications referenced below:

<i>EN 50081-2:1993</i>	<i>EMC Generic Industrial Emissions</i>
<i>EN 50082-2:1995</i>	<i>EMC Generic Industrial Immunity</i>
<i>EN 61131-2:1994/A11:1996</i>	<i>Low voltage requirements for programmable controllers</i>
<i>EN61326:1997</i>	<i>Electrical Equipment for measurement, control and Laboratory use – EMC requirements</i>

Year of Marking: 2002

<i>Signature</i>	
<i>Full Name</i>	Robert J. Kollmeyer
<i>Position</i>	Director of Engineering
<i>Place</i>	G & L Motion Control Inc.
<i>Date</i>	05-APR-05

**EC DECLARATION OF CONFORMITY**

The undersigned, representing the supplier  
**G & L Motion Control Inc.**  
**672 South Military Road**  
**Fond du Lac, Wisconsin 54936-1960**

herewith declares that all **servo drives and accessories** (see attached list of catalogue numbers) are in conformity with the provisions of the following EC Directive(s) when installed in accordance with the installation instructions contained in the product documentation:

*Low Voltage Directive as amended by 93/68/EEC*  
*EMC Directive as amended by 92/31/EEC and 93/68/EEC*

and that the standards and/or technical specifications referenced below have been applied:

- EN 60034-1:1998 + A1:1998 and A2:1999*      *Rotating Electrical Machines Part 1: Rating and Performance*
- EN 60204-1:1997*      *Safety of machinery – Electrical equipment of machines Part 1: Specifications for general requirements*
- EN 61800-3:1996*      *Adjustable Speed Electrical Power Drive Systems – EMC Product Standard Including Specific Test Methods*

Year of Marking: 2002

<i>Signature</i>	<i>Robert J Kollmeyer</i>
<i>Full Name</i>	Robert J. Kollmeyer
<i>Position</i>	Director of Engineering
<i>Place</i>	G & L Motion Control Inc.
<i>Date</i>	<i>05-APR-05</i>

**EC DECLARATION OF CONFORMITY**

The undersigned, representing the supplier

**G & L Motion Control Inc.  
672 South Military Road  
Fond du Lac, Wisconsin 54936-1960**

herewith declares that all **MMC Smart Drives (MMC-SD-XXX-230-XXX, MMC-SD-XXX-460-XXX) and accessories** are in conformity with the provisions of the following EC Directive(s) when installed in accordance with the installation instructions contained in the product documentation:

73/23/EEC  
89/336/EEC

*Low Voltage Directive as amended by 93/68/EEC  
EMC Directive as amended by 92/31/EEC and 93/68/EEC*

and that the standards and/or technical specifications referenced below have been applied:

EN 50178:1998  
EN 61800-3:1996  
/A11:2000

*Electronic equipment for use in power installations  
Adjustable speed electrical power drive systems – EMC  
product standard including specific test methods*

Year of Marking: 2003

Signature	<i>Robert J. Kollmeyer</i>
Full Name	Robert J. Kollmeyer
Position	Director of Engineering
Place	G & L Motion Control Inc.
Date	<i>05-APR-05</i>



---

## Appendix A - 460V MMC Smart Drive DC Bus Sharing

### A.1 Introduction

This section discusses DC bus sharing among 2 or more 460V Smart Drives.

DC bus sharing accomplishes 4 things:

- It pools the capacitance of all of the drives.
- It lowers electricity cost.
- It allows multiple drives to share one shunt resistor.
- It allows the shunt energy to be shared among multiple shunt resistors.

Pooling the capacitance increases the Joule energy absorption capability to the sum of the drives connected ([Table A-2 on page 210](#)). This lowers energy cost slightly because energy that can be absorbed is not wasted in the shunt resistors. In some applications, this can eliminate the need for a shunt resistor altogether.

Many applications will have one drive motoring while the other is regenerating. This energy is transferred from one drive to the other through the DC bus rather than being dissipated in a shunt. This saves energy cost.

If it is desired to share one shunt resistor instead of using one per drive, the energy flows through the DC bus to the drive controlling the shunt resistor. Its internal circuitry will turn the shunt on when the bus voltage reaches an upper limit.

If it is desired to distribute the shunt load among multiple drives, each having a smaller resistor, then **it is important to interconnect the “Shunt On” signals for all drives sharing the DC bus**. This ensures that all of the shunt resistors will properly share the load. If this connection is not made, it is likely that only one shunt resistor will dissipate all of the shunt power, overheating it.

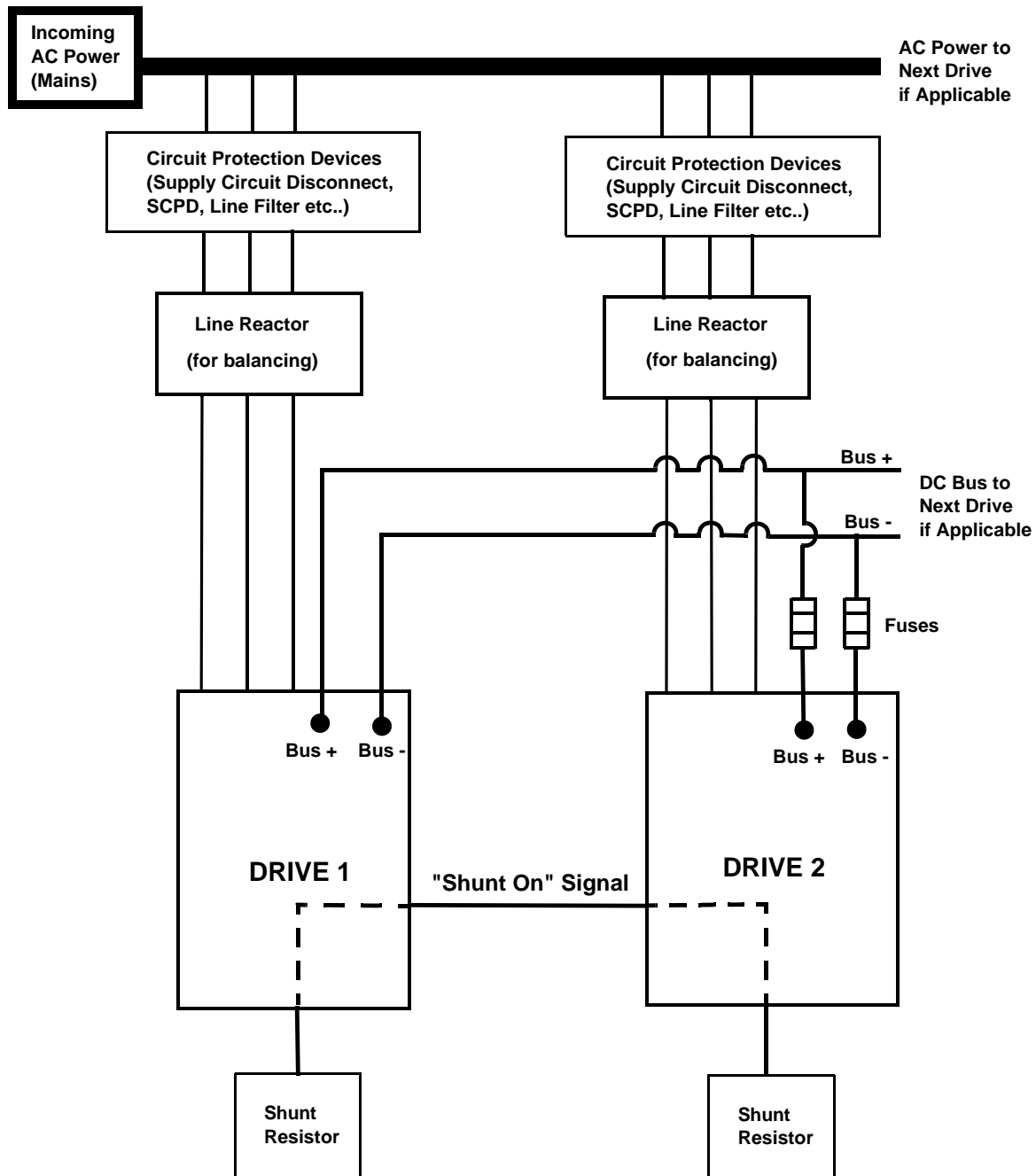
### A.2 DC Bus Sharing with AC Power to All Drives

When sharing DC power among several drives with AC power supplying all of the drives ([Figure A-1](#)), all drives must be the same size (for example, all drives must be MMC-SD-4.0-460). When two drives are connected to a shared DC bus in this manner, the combined energy absorption of all drives is available.

3% line reactors are required for all sizes using this configuration to ensure rectifier balance. However, shunt resistors are optional (see below). Refer to Chapter 4 in this manual for information related to fusing, line reactors and shunts. Refer to Chapter 6 for connector information.

When more than one shunt is used with the MMC Smart Drives, it is important to tie the “Shunt On” circuits together so that all shunts get turned on at the same time. For example, in [Figure A-1](#), if the shunt connected to Drive 1 turns on, the “Shunt On” signal will turn on the shunt for Drive 2. The second shunt resistor is optional as long as the “Shunt On” signal is connected as shown. The “Shunt On” signal acts as both an input and an output for each Drive.

Figure A-1: DC Bus Sharing with AC Input Power to All Drives



### A.3 DC Bus Sharing with AC Power to One Drive

When sharing DC power among several drives with AC power supplying just one of the drives ([Figure A-2](#)), all drives need not be the same size (for example, one drive may be a MMC-SD-8.0-460, and another drive may be a MMC-SD-1.3-

460). When two or more drives are connected to a shared DC bus in this manner, there are two limits that must be considered:

- The drives not powered by AC must not consume more power than the “Bus power available for linking to other drives” as listed in [Table A-1](#).
- The total power consumed by all drives cannot exceed the greater of “Bus power available for linking to other drives” and the kW rating of the AC powered drive as listed in [Table A-1](#).

For example, assume that the AC powered drive is a MMC-SD-24.0-460 and consumes 14kW, and supplies DC power to two more drives that consume 4kW each (8kW total). From [Table A-1](#), the total DC power available to the non-AC powered drives is 10kW, meeting the first criteria. The total power consumed is 22kW, and since the AC powered drive is a 24kW drive, meets the second criteria.

The continuous current available from the drive would be reduced by the same percentage as the kW. In the example given, the available kW was reduced from 24 to 16kW. Therefore  $16/24 = 67\%$ . The drive’s continuous current is reduced by 1/3 from 45 Amps to 30 Amps.

If peak current is to be used at the same time on more than one drive, the total peak current used by all drives must not exceed that of the main drive. If both the main and auxiliary drives will accelerate at the same time, the peak current used by auxiliary drives is subtracted from the available peak current of the main drive. Connection of a shunt to the main drive is optional depending on the results found in sizing the system. The system will have the combined DC Bus capacitance of all drives connected.

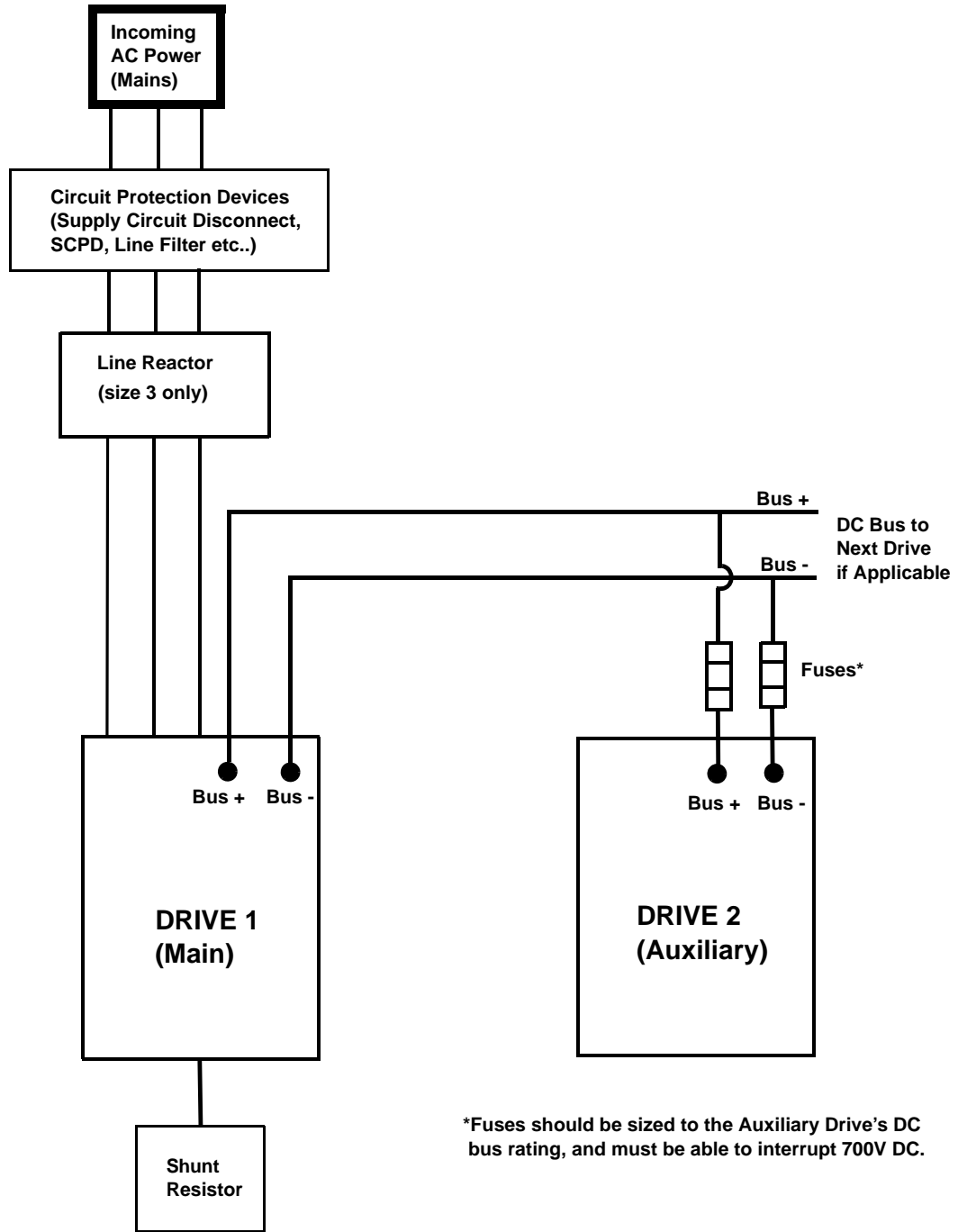
[Table A-2 on page 210](#) shows the MMC Smart Drive bus capacitance and energy absorption capability.

:

<b>Table A-1: kW Ratings for Powered Drive</b>			
<b>Drive Model</b>	<b>Bus power available for linking to other drives</b>	<b>Continuous Current (Amps)</b>	<b>Peak Current (Amps)</b>
MMC-SD-1.3-460	2.0kW	3	6
MMC-SD-2.4-460	2.0kW	5.5	11
MMC-SD-4.0-460	5.0kW	9	18
MMC-SD-6.0-460	5.0kW	13.5	27
MMC-SD-8.0-460	5.0kW	18	36
MMC-SD-12.0-460	10.0kW	27.5	55
MMC-SD-16.0-460	10.0kW	36.5	73
MMC-SD-24.0-460	10.0kW	55	110
MMC-SD-30.0-460	10.0kW	69.3	110
MMC-SD-42.0-460	36.0kW	93.3	147
MMC-SD-51.0-460	45.0kW	117.4	184
MMC-SD-65.0-460	58.0kW	152.7	209



Figure A-2: Two or more drives with AC input power to one drive



<b>Table A-2: Drive Bus Capacitance and energy Absorption Capability</b>				
<b>Drive<sup>a</sup></b>	<b>MMC Smart Drive Bus Capacitance (μFarad)</b>	<b>Energy Absorption at 230V Line Input and 230V Motor (Joules)</b>	<b>Energy Absorption at 230V Line Input and 460V Motor (Joules)</b>	<b>Energy Absorption at 460V Line Input and 460V Motor (Joules)</b>
<b>460V Size 1</b>				
MMC-SD-1.3-460	110	3	28	10
MMC-SD-2.4-460	240	7	60	22
<b>460V Size 2</b>				
MMC-SD-4.0-460	470	13	118	44
MMC-SD-6.0-460	470	13	118	44
MMC-SD-8.0-460	705	19	177	66
<b>460V Size 3</b>				
MMC-SD-12.0-460	820	22	206	76
MMC-SD-16.0-460	1230	33	309	114
MMC-SD-24.0-460	1640	45	412	152
MMC-SD-30.0-460	2000	55	502	185
<b>460V Size 4</b>				
MMC-SD-42.0-460	1880	50.4	472	173
MMC-SD-51.0-460	2350	63.1	591	218
MMC-SD-65.0-460	3055	82	768	284
<b>230 V<sup>b</sup></b>				
MMC-SD-0.5-460	1410	38		
MMC-SD-1.0-460	1880	51		
MMC-SD-2.0-460	1880	51		

a. add suffix (-D) for Digital Drive

b. add suffix (-D) for Digital Drives and (-DN) for Digital Narrow Drives

# Index

## A

Altitude [80](#), [114](#)  
application  
wiring [25](#), [168](#)

## B

battery  
disposal [179](#)  
type [179](#)  
block I/O  
port  
pinout [173](#)  
bonding  
mounting [20](#)

## C

cables  
pin assignments  
HSM and FSM motors [144](#)  
I/O [136](#)  
LSM and MSM motors [137](#)  
XSM motors [140](#)  
YSM motors [146](#)

## CE

filter requirements [24](#)

## conformity

european directives [18](#)  
UL and cUL standards [18](#)

## connections

general outputs [177](#)  
general purpose inputs [178](#)  
MMC CPU module [173](#)

## connector

block I/O [173](#)  
ethernet [174](#)  
general I/O [175](#)  
user port [174](#)

## connectors

230V 24VDC IN/Brake [78](#)  
230V F1 feedback [70](#)  
230V F2 feedback [73](#)  
230V motor [79](#)  
size 1 460V drive [92](#)  
size 2 460V drive [97](#)  
size 3 460V drive [102](#), [107](#)

contents of the manual [9](#)

## control cabinet

requirements [21](#)

## D

diagnostic  
error codes [152](#), [159](#)  
LED [170](#)  
run-time [172](#)  
troubleshooting [171](#)

## Diagnostics

diagnostics  
power on [151](#)  
run-time [152](#)  
runtime [152](#)

## dimensions

230V drive [85](#), [86](#), [87](#), [88](#)  
460V drive [125](#)  
cabinet clearance [19](#)  
motor cable [31](#)  
shunts [50](#)

## distribution

power [28](#)

download hex [169](#)

## E

electrical service & maintenance safety [14](#)

## EMI (ElectroMagnetic Interference)

bonding [20](#)

## error codes

diagnostic [152](#), [159](#)  
digital MMC control [172](#)  
drive fault [153](#)  
drive warning codes [159](#)

## ethernet

port  
pinout [174](#)

## F

## faults

diagnostic [152](#), [159](#)

features of the MMC Smart Drive [9](#)

filter, AC power [24](#)

flash memory [179](#)

## G

## general I/O

port pinout [175](#)

## general inputs

sinking/sourcing [178](#)

## general outputs

connections [177](#)

## general purpose inputs

connections [178](#)

## grounding

CE single phase 230V drive system [24](#)  
multiple drives [25](#)

protective earth [12](#)  
system [22](#)

## H

handling the MMC Smart Drive [17](#)  
heat  
    controlling [19](#)  
hex  
    download [169](#)  
Humidity [80](#), [114](#)

## I

inspection  
    safety [13](#)  
installation [18](#)  
installing [17](#)  
isolation transformers  
    230V formula [48](#)  
    460V formula [48](#)

## L

LEDs  
    230V single phase drive [61](#)  
    460V analog 3-Phase drive [91](#)  
    diagnostic [170](#)  
    error codes [152](#), [159](#)  
    power [170](#)  
    scan [170](#)  
line filters  
    block diagram for 3-phase [54](#)  
    CE compliance [53](#)  
    connection diagram for 3-phase [54](#)  
    technical data  
        230V [56](#)  
        460V [57](#)  
line reactors [196](#)

## M

maintenance [151](#)  
manual cleaning procedure [15](#)  
MMC  
    connecting to an application [169](#)  
    CPU  
        module connections [173](#)  
    overview [165](#)  
    ports [166](#)  
    power [29](#)  
    Servo Control Unit [166](#)  
    specifications [179](#)  
mounting [21](#)  
    bonding [20](#)

## N

noise  
    see bonding [20](#)

## O

operation  
    safety [14](#)  
    startup [169](#)  
overview  
    MMC [165](#)

## P

part numbers  
    breakout boards, cables and kits [187](#)  
    connector kits [185](#), [186](#)  
    drive connect cables [185](#)  
    drives [181](#), [182](#)  
    LSM and MSM feedback cables [190](#), [193](#)  
    optional external devices [196](#)  
PiCPro  
    port pinout [173](#)  
PiCPro port  
    Standalone MMC Control [65](#)  
pinout  
    block I/O port [173](#)  
    ethernet port [174](#)  
    general I/O port [175](#)  
    PiCPro port [173](#)  
    user port [174](#)  
power  
    distribution in MMC [28](#)  
    LED [170](#)  
procedure  
    manual cleaning [15](#)  
protective earth  
    grounding [12](#)

## R

Requirements  
    Transformer [35](#)  
resolver  
    installing [161](#), [162](#)  
resolver module  
    installing [161](#)  
    theory of operation [161](#)  
run-time diagnostics [172](#)

## S

safety  
    after shutdown [13](#)  
    cleaning [15](#)  
    electrical service & maintenance [14](#)

- inspection [13](#)
- operating safely [14](#)
- operation [14](#)
- signs [12](#)
- system [11](#)
- warning labels [12](#)
- Sales and Service [214](#)
- scan
  - LED [170](#)
- Service [214](#)
- shields [26](#)
- Shock [80](#), [114](#)
- shunts
  - choosing [48](#)
  - dimensions [50](#)
- signs
  - safety [12](#)
- single point ground (SPG)
  - checklist [22](#)
- software
  - required [10](#)
- specifications
  - 230V MMC Smart Drive [80](#)
  - Altitude [80](#), [114](#)
  - Humidity [80](#), [114](#)
  - MMC [179](#)
  - optional resolver module [164](#)
  - Shock [80](#), [114](#)
  - Storage Temperature [80](#), [114](#)
  - Vibration [80](#), [114](#)
- Standalone MMC Control
  - PiCPro port [65](#)
- storage
  - before installation [17](#)
  - Temperature [80](#), [114](#)
- storing the drive [17](#)
- switch
  - main disconnect
    - wiring modules [170](#)
- system mounting requirements
  - ventilation [18](#)

**T**

- technical support contacts [10](#)
- Transformer
  - Size [35](#)
- troubleshooting [169](#)
  - digital MMC error codes [172](#)
  - drive error codes [153](#)
  - drive warning codes [159](#)
  - general [152](#)
  - hardware wiring [151](#)
  - mmc control [170](#)

**U**

- Unpacking [17](#)
- user port
  - pinout [174](#)

**V**

- ventilation [18](#)
- Vibration [80](#), [114](#)

**W**

- warning label
  - danger, warning, caution [13](#)
  - hazard [12](#)
- Web Address [214](#)
- wiring
  - application [25](#), [168](#)
  - connecting shunt modules [148](#)
  - connections for 3-phase line filter [54](#)
  - connectors on 230V drive [63](#)
  - drive I/O connector [77](#)
  - EMC compliant [25](#), [168](#)
  - interface cables [30](#)
  - preparing motor connection wires [31](#)
  - routing high/low voltage cables [30](#)
  - terminating 230V motor power cable [32](#)
  - terminating 460V power cable [33](#)

## Sales and Service

We are committed to quality customer service. In order to serve in the most effective way, please contact your local sales representative for assistance.

If you are unaware of your local sales representative, please contact us.

### North America

#### Danaher Motion Customer Support North America

E-mail: [glmotion.support@danahermotion.com](mailto:glmotion.support@danahermotion.com)  
Phone: In the United States, telephone (800) 558-4808  
Outside the United States, telephone (920) 921-7100  
Fax: (920) 906-7669  
Web site: [www.glcontrols.com](http://www.glcontrols.com)

### Europe

#### Danaher Motion Customer Support Europe

E-mail: [glmotion.support@danahermotion.com](mailto:glmotion.support@danahermotion.com)  
Phone: +44 (0)1525 243-243  
Fax: +44 (0)1525 243-244  
Web site: [www.glcontrols.com](http://www.glcontrols.com)

