

MMC Smart Drive™ and Digital MMC Control

Hardware Manual

Version 2.1

NOTE

Progress is an on-going commitment at G & L Motion Control Inc. We continually strive to offer the most advanced products in the industry; therefore, information in this document is subject to change without notice. The text and illustrations are not binding in detail. G & L Motion Control Inc. shall not be liable for any technical or editorial omissions occurring in this document, nor for any consequential or incidental damages resulting from the use of this document.

G &L Motion Control Inc. makes every attempt to ensure accuracy and reliability of the specifications in this publication. Specifications are subject to change without notice. G & L Motion Control Inc. provides this information “AS IS” and disclaims all warranties, express or implied, including, but not limited to, implied warranties of merchantability and fitness for a particular purpose. It is the responsibility of the product user to determine the suitability of this product for a specific application.

DO NOT ATTEMPT to use any G & L Motion Control Inc. product until the use of such product is completely understood. It is the responsibility of the user to make certain proper operation practices are understood. G & L Motion Control Inc. products should be used only by qualified personnel and for the express purpose for which said products were designed.

Should information not covered in this document be required, contact the Customer Service Department, G & L Motion Control Inc., 672 South Military Road, P.O. Box 1960, Fond du Lac, WI 54936-1960. G & L Motion Control Inc. can be reached by telephone at (920) 921-7100 or (800) 558-4808 in the United States or by e-mail at glmotion.support@danahermotion.com.

Catalog No. (Order No.) M.1301.5524

Electronic Version Part No. M.1302.8699

Release 2109

©2005, G & L Motion Control Inc.

Third party brands and trademarks are the property of their respective owners

Table of Contents:

MMC Smart Drive and Digital MMC Control Hardware Manual

1 Introduction to the MMC Smart Drive (MMC-SD)	8
1.1 Overview	8
1.2 Contents of This Manual	9
1.3 Software and Manuals	9
1.3.1 Required Software and Manuals	9
1.3.2 Suggested Manuals	10
1.4 G&L Motion Control Support Contact	10
2 Safety Precautions	11
2.1 System Safety	11
2.1.1 User Responsibility	11
2.1.2 Safety Instructions	12
2.2 Safety Signs	12
2.3 Warning Labels	13
2.4 Safety First	13
2.5 Safety Inspection	14
2.5.1 Before Starting System	14
2.6 After Shutdown	14
2.7 Operating Safely	14
2.8 Electrical Service & Maintenance Safety	15
2.9 Safe Cleaning Practices	17
3 Installing the Drive	18
3.1 Storing the Drive Before Installation	18
3.2 Unpacking the Drive	18
3.3 Handling an MMC Smart Drive	18
3.4 Inspecting the Drive Before Installation	19
3.5 Complying with European Directives	19
3.6 Conforming with UL and cUL Standards	19
3.7 General Installation and Ventilation Requirements	19
3.8 Controlling Heat Within the System	21
3.9 Bonding	22
3.9.1 Bonding a Subpanel Using a Stud	22
3.9.2 Bonding a Ground Bus Using a Stud	22
3.9.3 Bonding a Ground Bus or Chassis Using a Bolt	23
3.9.4 Grounding Multiple Drive Cabinets	23
3.9.5 Bonding Multiple Subpanels	24
3.10 Drive Mounting Guidelines	24
3.11 Drive System Grounding Procedures	25
3.11.1 Grounding Requirements	27
3.11.2 Grounding Multiple Drives in the Same Cabinet	29

3.12 System Wiring Guidelines	29
3.12.1 Recommended Signal Separation	30
3.12.2 Building Your Own Cables	32
3.12.3 Routing Cables	32
3.13 Wiring the Drive	32
3.13.1 Sizing the 24V Power Supply	32
3.13.2 System AC Power Wiring Guidelines	34
3.13.3 Connecting Interface Cables	35
3.13.4 Preparing Motor Connection Wires	36
4 System Power Protection and Related Devices	39
4.1 Motor Overload Protection	39
4.2 Fuses	39
4.2.1 Fuse Sizing	39
4.2.2 Device Protection	40
4.3 Short Circuit Protection	41
4.4 Line Reactors	42
4.4.1 Specifications and Dimensions for Required Line Reactors	43
4.5 Isolation Transformers	46
4.6 External Shunts	47
4.6.1 Choosing an External Shunt	47
4.6.2 External Shunt Resistor Kits	48
4.6.3 Mounting Dimensions for External Shunts	49
4.7 Line Filters	53
4.7.1 Line Filters and CE Compliance	53
4.7.2 Part Numbers for AC Line Filters	55
4.8 Technical Data for AC Line Filters	55
4.8.1 Technical Data for 230V Line Filters	55
4.8.2 Technical Data for 460V Line Filters	56
4.8.3 Dimensions for AC Line Filters	57
4.8.4 230V Line Filter Dimensions	57
4.8.4.1 460V Line Filter Dimensions	58
5 230V Single Phase MMC Smart Drive.....	59
5.1 LEDs	59
5.2 Connectors and Switches on the 230V Drive	60
5.2.1 PiCPro Communication Port	61
5.2.1.1 PiCPro Port (P1)	61
5.2.2 Node Address Rotary Switch (Digital Interfaced MMC-SD Only)	63
5.2.3 Digital Link Connector (IN/OUT) (Digital Interfaced MMC-SD Only)	63
5.2.4 Feedback Connector (F1)	65
5.2.5 Feedback Connector (F2) (Digital Interfaced MMC-SD Only)	68
5.2.6 User I/O Connector (IO)	70
5.2.7 24 VDC IN/Brake Terminal Strip	73
5.2.8 Motor Terminal Strip	74
5.3 Specifications - 230V MMC Smart Drive	75

5.3.1	General Data for all 230V Models	75
5.3.2	Physical and Electrical Data for 230V Drives	78
5.4	Dimensions for 230V MMC Smart Drive	80
5.4.1	230V 500W Drive - Front View	80
5.4.2	230V 500W Drive - Side View	81
5.4.3	230V 1kW and 2kW Drive - Front View	82
5.4.4	230V 1kW and 2kW Drive - Side View	83
6	460V 3-Phase MMC Smart Drive	84
6.1	LEDs	84
6.2	Connectors on the 460V Drive	85
6.2.1	Size 1 460V Drive Connectors	85
6.2.1.1	Shunt/DC Bus Terminals	86
6.2.1.2	AC Power Terminal Strip	87
6.2.1.3	Motor Terminals	87
6.2.1.4	24V Power Connector (J1)	88
6.2.1.5	Motor Brake Terminals (X101)	89
6.2.2	Size 2 460V Drive	90
6.2.2.1	AC Power Terminals	91
6.2.2.2	Motor Power Terminals	92
6.2.2.3	24V Power Connector (J1)	93
6.2.2.4	Motor Brake Terminals (X101)	94
6.2.3	Size 3 460V Drive	95
6.2.3.1	AC Power Terminals	96
6.2.3.2	Motor Power Terminals	97
6.2.3.3	24V Power Connector (J1)	98
6.2.3.4	Motor Brake Terminals (X101)	99
6.3	Typical 460V Drive Connection Layout	100
6.4	Specifications - 460V MMC Smart Drive	101
6.4.1	Common Data for Size 1/Size 2/Size 3 (All Models)	101
6.4.2	Physical/Electrical Data for 460V Size 1 Drives	104
6.4.3	Physical/Electrical Data for 460V Size 2 Drive	106
6.4.4	Physical/Electrical Data for 460V Size 3 Drive	108
6.5	Dimensions for the 460V Drives	110
6.5.1	Size 1 460V Drive - Front View	110
6.5.2	Size 1 460V Drive - Side View	111
6.5.3	Size 2 460V Drive - Front View	112
6.5.4	Size 2 460V Drive - Side View	113
6.5.5	Size 3 460V Drive - Front View	114
6.5.6	Size 3 460V Drive - Side View	115
7	Cables and Connections to External Devices	116
7.1	I/O Cable Pin Assignments	116
7.2	LSM and MSM Motors Cable Pin Assignments	117
7.3	XSM Motors Cable Pin Assignments	119
7.4	NSM Motors Cable Pin Assignments	121
7.5	HSM and FSM Motors Cable Pin Assignments	123
7.6	YSM Motors Cable Pin Assignments	125

7.7 Connecting Shunt Modules	127
7.7.1 Connecting the 230V MMC Smart Drive to 300 W Shunt Module	127
7.7.2 Connecting the 460V MMC Smart Drive to G&L Motion Control Shunt Modules	128
8 Maintenance and Troubleshooting.....	130
8.1 Maintenance	130
8.2 Diagnostics.....	130
8.2.1 Power-On Diagnostics	130
8.2.1.1 Power LED	130
8.2.1.2 Diagnostic LEDs	131
8.2.2 Run-Time Diagnostics	131
8.3 Troubleshooting.....	132
8.3.1 General Troubleshooting	132
8.3.2 Troubleshooting Drive Diagnostic Error Codes	132
8.3.3 Troubleshooting Warning Error Codes	138
9 Resolver Interface Option Module	139
9.1 Theory of Operation	139
9.2 Installing the Resolver Module	139
9.3 Specifications	141
10 MMC Smart Drive Control.....	142
10.1 Introduction.....	142
10.1.1 Overview	142
10.1.2 Major Components	143
10.2 Installing the MMC Smart Drive Control.....	144
10.2.1 Installing the MMC Smart Drive Control into a Digital Interfaced 230V MMC-SD Drive	144
10.2.2 Installing the MMC Smart Drive Control into a Digital Interfaced 460V MMC-SD Drive	145
10.3 System Wiring Guidelines.....	146
10.4 Starting an Operation.....	148
10.4.1 Connecting the MMC to the Application	148
10.4.2 Basic Setup and Maintenance Procedures	149
10.4.3 Start-up Diagnostics	150
10.4.3.1 Power LED	150
10.4.3.2 Scan LED	150
10.4.3.3 MMC Start-Up Diagnostic LEDs	150
10.4.4 MMC Run-Time Diagnostics	151
10.5 MMC Connections to External Devices for Machine Control	152
10.5.1 PiCPro Port (P1)	152
10.5.2 Block I/O Port (C1)	153
10.5.3 User Port (C3)	153
10.5.4 Ethernet Port (C4)	154
10.5.5 General I/O Port (C5)	155
10.6 Specifications	159

11 Part Numbers	160
11.1 Drives	160
11.2 Option Modules	161
11.2.1 Resolver Interface Option Module	161
11.2.2 MMC Smart Drive Control	161
11.3 Direct Connect Cables	161
11.3.1 Drive Programming Cable	161
11.3.2 Standalone MMC to MMC Smart Drive I/O Cable	161
11.4 Digital Link and Networking Cables	162
11.5 Connector Kits	162
11.6 Breakout Boards/Flying Leads Cables and Kits	163
11.6.1 Mounted Breakout Boards	163
11.6.2 Panel Mounted Breakout Boards	163
11.6.3 Breakout Board Kits	163
11.6.4 Breakout Board Cables	164
11.6.5 User I/O Flying Lead Cables	165
11.7 Motor Cables (LSM/MSM Motors)	166
11.7.1 Feedback Cables (LSM/MSM Motors)	166
11.7.2 Power Cables for Blower Fan (LSM/MSM Motors)	166
11.7.3 Motor Power Cables (LSM/MSM Motors)	167
11.8 Optional External Devices	168
11.8.1 AC Line Filters	168
11.8.2 AC Line Reactors	168
11.8.3 External Shunt Resistor Kits	169
11.9 Software	169
12 Declarations of Conformity	170
Appendix A - 460V MMC Smart Drive DC Bus Sharing.....	A1-1
1 Introduction.....	A1-1
2 DC Bus Sharing with AC Power to All Drives	A1-1
3 DC Bus Sharing with AC Power to One Drive	A1-3
INDEX.....	IND-1

1 Introduction to the MMC Smart Drive (MMC-SD)

1.1 Overview

This manual covers two distinct products:

- The Analog Interfaced MMC-SD which receives motion commands via a $\pm 10\text{V}$ analog input
- The Digital MMC-SD which receives motion commands via a digital connection (Digital Link)

Unless otherwise noted, all of the information in this manual applies to both drives.

Features include:

- 230V, Single Phase drives available with power ratings of .5kW, 1kW, and 2 kW
- 460V, Three Phase drives available with power ratings of 1.3kW through 24kW
- Drive firmware in user upgradeable Flash memory
- Serial port for communications with PC-resident PiCPro
- Internal switch to control a mechanical brake
- Green Power LED and yellow Diagnostic LED
- Motor feedback types include incremental encoder, high resolution encoder, and resolver.
- Eight General Purpose 24VDC Inputs
- Four General Purpose 24VDC outputs
- $\pm 10\text{V}$ command input (Analog Interfaced MMC-SD only)
- Digital Link digital connections (Digital MMC-SD only)
- Optional MMC-SD Control (for Digital MMC-SD only)
- UL Listed and CE Marked.

1.2 Contents of This Manual

This manual includes the following major topics:

- Information to safely operate and maintain the equipment in a safe manner.
- User responsibilities for product acceptance and storage.
- Power and environmental information for general power, control cabinet, grounding, heat control and handling.
- Procedures for mounting, wiring, and connecting the MMC Smart Drive and standard G&L Motion Control motors recommended for use with the MMC Smart Drive.
- Recommended drive system wiring guidelines for signal separation and differential devices. Methods to ensure ElectroMagnetic Compatibility.
- The location of connectors on the drive and descriptions of their functionality including I/O, encoder, serial interface and motor/brake connector locations and signal descriptions.
- Physical, electrical, environmental and functional specifications/dimensions.
- Description of the minimal maintenance necessary.
- A troubleshooting chart of potential problems and possible solutions.
- Part numbers and descriptions for the drive and related equipment.

1.3 Software and Manuals

1.3.1 Required Software and Manuals

- PicPro V15.1 (one of the following)
 - Professional Edition
 - MMC Limited Edition
 - Monitor Edition

1.3.2 Suggested Manuals

- Function/Function Block Reference Guide V15.1
- Motion Application Specific Function Block Manual V15.0.1
- Ethernet Application Specific Function Block Manual V15.1.1
- General Purpose Application Specific Function Block Manual V13.0.1

1.4 G&L Motion Control Support Contact

Contact your local G&L Motion Control representative for:

- Sales and order support
- Product technical training
- Warranty support
- Support service agreements

G&L Motion Control Technical Support can be reached:

- In the United States, telephone (800) 558-4808
- Outside the United States, telephone (920) 921-7100
- In Europe, telephone (+44)151-546-2010,
fax (+44)151-547-2801
- E-mail address:
glmotion.support@danahermotion.com

2 Safety Precautions

READ AND UNDERSTAND THIS SECTION IN ITS ENTIRETY BEFORE UNDERTAKING INSTALLATION OR ADJUSTMENT OF THE MMC SMART DRIVE AND ANY ASSOCIATED SYSTEMS OR EQUIPMENT

The instructions contained in this section will help users to operate and maintain the equipment in a safe manner.

PLEASE REMEMBER THAT SAFETY IS EVERYONE'S RESPONSIBILITY

2.1 System Safety

The basic rules of safety set forth in this section are intended as a guide for the safe operation of equipment. This general safety information, along with explicit service, maintenance and operational materials, make up the complete instruction set. All personnel who operate, service or are involved with this equipment in any way should become totally familiar with this information prior to operating.

2.1.1 User Responsibility

It is the responsibility of the user to ensure that the procedures set forth here are followed and, should any major deviation or change in use from the original specifications be required, appropriate procedures should be established for the continued safe operation of the system. It is strongly recommended that you contact your OEM to ensure that the system can be safely converted for its new use and continue to operate in a safe manner.

2.1.2 Safety Instructions

1. Do not operate your equipment with safety devices bypassed or covers removed.
2. Only qualified personnel should operate the equipment.
3. Never perform service or maintenance while automatic control sequences are in operation.
4. To avoid shock or serious injury, only qualified personnel should perform maintenance on the system.

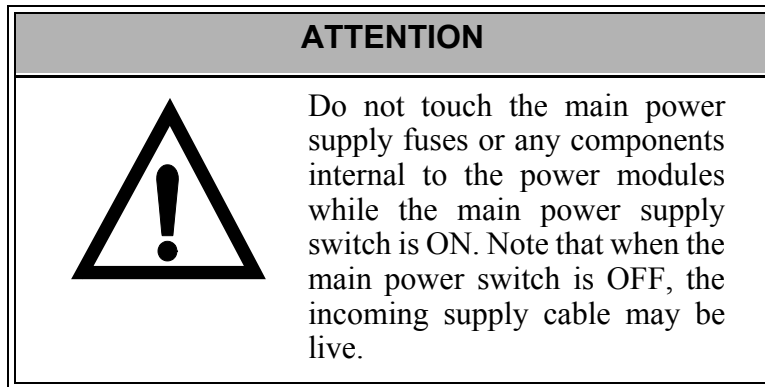

5. **GROUNDING (Protective Earth)**
The equipment must be grounded (connected to the protective earth connection) according to OEM recommendations and to the latest local regulations for electrical safety. The grounding (protective earth) conductor must not be interrupted inside or outside the equipment enclosures. The wire used for equipment grounding (connection to protective earth) should be green with a yellow stripe.

2.2 Safety Signs

The purpose of a system of safety signs is to draw attention to objects and situations which could affect personal or plant safety. It should be noted that the use of safety signs does not replace the need for appropriate accident prevention measures. Always read and follow the instructions based upon the level of hazard or potential danger.

2.3 Warning Labels

Hazard warning

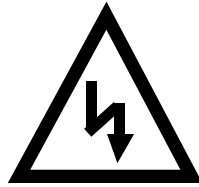

Danger Electric
Shock Risk

When you see this safety sign on a system, it gives a warning of a hazard or possibility of a hazard existing. The type of warning is given by the pictorial representation on the sign plus text if used.

To ignore such a caution could lead to severe injury or death arising from an unsafe practice.

Danger, Warning, or Caution warning



Symbol plus DANGER, WARNING or CAUTION:
These notices provide information intended to prevent potential personal injury and equipment damage.

Hot Surface warning

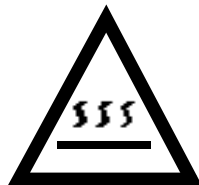

Symbol plus HOT SURFACE:
These notices provide information intended to prevent potential personal injury.

2.4 Safety First

G&L Motion Control equipment is designed and manufactured with consideration and care to generally accepted safety standards. However, the proper and safe performance of the equipment depends upon the use of sound and prudent operating, maintenance and servicing procedures by trained personnel under adequate supervision.

For your protection, and the protection of others, learn and always follow these safety rules. Observe warnings on machines and act accordingly. Form safe working habits by reading the rules and abiding by them. Keep these safety rules handy and review them from time to time to refresh your understanding of them.

2.5 Safety Inspection

2.5.1 Before Starting System

1. Ensure that all guards and safety devices are installed and operative and all doors which carry warning labels are closed and locked.
2. Ensure that all personnel are clear of those areas indicated as potentially hazardous.
3. Remove (from the operating zone) any materials, tools or other objects that could cause injury to personnel or damage the system.
4. Make sure that the control system is in an operational condition.
5. Make certain that all indicating lights, horns, pressure gauges or other safety devices or indicators are in working order.

2.6 After Shutdown

Make certain all controlled equipment in the plant is safe and the associated electrical, pneumatic or hydraulic power is turned off. It is permissible for the control equipment contained in enclosures to remain energized provided this does not conflict with the safety instructions found in this section.

2.7 Operating Safely

1. Do not operate the control system until you read and understand the operating instructions and become thoroughly familiar with the system and the controls.
2. Never operate the control system while a safety device or guard is removed or disconnected
3. Where access to the control system is permitted for manual operation, only those doors which provide that access should be unlocked. They should be locked immediately after the particular operation is completed.
4. Never remove warnings that are displayed on the equipment. Torn or worn labels should be replaced.
5. Do not start the control system until all personnel in the area have been warned.
6. Never sit or stand on anything that might cause you to fall onto the control equipment or its peripheral equipment.

7. Horseplay around the control system and its associated equipment is dangerous and should be prohibited.
- 8.

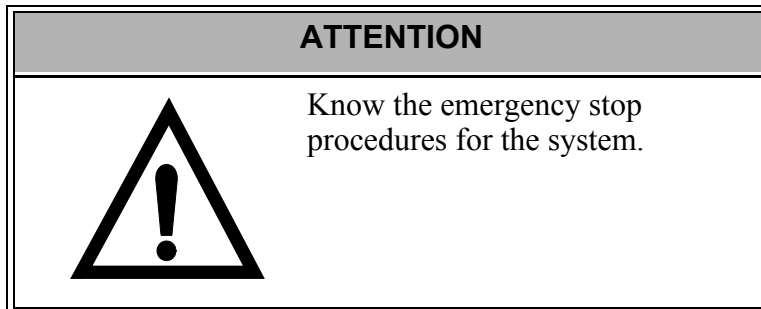

9. Never operate the equipment outside specification limits.
10. Keep alert and observe indicator lights, system messages and warnings that are displayed on the system.
11. Do not operate faulty or damaged equipment. Make certain proper service and maintenance procedures have been performed.

2.8 Electrical Service & Maintenance Safety

1. **ALL ELECTRICAL OR ELECTRONIC MAINTENANCE AND SERVICE SHOULD BE PERFORMED BY TRAINED AND AUTHORIZED PERSONNEL ONLY.**
2. It should be assumed at all times that the POWER is ON and all conditions treated as live. This practice assures a cautious approach which may prevent accident or injury.
3. To remove power:
LOCK THE SUPPLY CIRCUIT DISCONNECTING MEANS IN THE OPEN POSITION.
APPLY LOCKOUT/TAGOUT DEVICES IN ACCORDANCE WITH A DOCUMENTED AND ESTABLISHED POLICY.
4. Make sure the circuit is safe by using the proper test equipment. Check test equipment regularly

5.

ATTENTION	
	Care should be taken if you are manually discharging the bus capacitors.

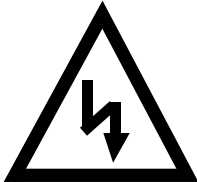
WARNING	
	Even after power to the drive is removed, it may take up to 10 minutes for bus capacitors to discharge to a level below 50 VDC. To be sure the capacitors are discharged, measure the voltage across the + and - terminals for the DC bus.

6. There may be circumstances where troubleshooting on live equipment is required. Under such conditions, special precautions must be taken:
 - Make sure your tools and body are clear of the areas of equipment which may be live.
 - Extra safety measures should be taken in damp areas.
 - Be alert and avoid any outside distractions.
 - Make certain another qualified person is in attendance.
7. Before applying power to any equipment, make certain that all personnel are clear of associated equipment.
8. Control panel doors should be unlocked only when checking out electrical equipment or wiring. On completion, close and lock panel doors.
9. All covers on junction panels should be fastened closed before leaving any job.
10. Never operate any controls while others are performing maintenance on the system.
11. Do not bypass a safety device.
12. Always use the proper tool for the job.
13. Replace the main supply fuses only when electrical power is OFF (locked out).

2.9 Safe Cleaning Practices

1. Do not use toxic or flammable solvents to clean control system hardware.
2. Turn off electrical power (lock out) before cleaning control system assemblies.
3. Keep electrical panel covers closed and power off when cleaning an enclosure.
4. Always clean up spills around the equipment immediately after they occur.
5. Never attempt to clean a control system while it is operating.
6. Never use water to clean control equipment unless you are certain that the equipment has been certified as sealed against water ingress. Water is a very good conductor of electricity and the single largest cause of death by electrocution.

3 Installing the Drive

Note: The National Electrical Code and any other governing regional or local codes overrule the information in this manual. G & L Motion Control Inc. does not assume responsibility for the user's compliance or non-compliance with any code, national, local or otherwise, for the proper installation of this drive and associated systems or equipment. Failure to abide by applicable codes creates the hazard of personal injury and/or equipment damage.

3.1 Storing the Drive Before Installation

The drive should remain in the shipping container prior to installation. If the equipment is not to be used for a period of time, store it as follows:

- Use a clean, dry location
- Maintain the storage temperature and humidity as shown in the specifications section of this manual.
- Store it where it cannot be exposed to a corrosive atmosphere
- Store it in a non-construction area

3.2 Unpacking the Drive

Remove all packing material, wedges, and braces from within and around the components. After unpacking, check the name plate Material Number against the purchase order of the item(s) against the packing list. The model number, serial number and manufacturing date code are located on the side of the unit.

3.3 Handling an MMC Smart Drive

The case protects the MMC Smart Drive's internal circuitry against mechanical damage in shipping and handling.

However, like any electronic device, the circuitry can be destroyed by:

- Conditions exceeding those detailed in the specifications tables shown in the Specifications sections in this manual.
- moisture condensing inside the module
- static discharge
- exposure to a magnetic field strong enough to induce a current in the circuitry
- vibration, and other hazards

3.4 Inspecting the Drive Before Installation

Inspect the unit for any physical damage that may have been sustained during shipment.

If you find damage, either concealed or visible, contact your buyer to make a claim with the shipper. If degraded performance is detected when testing the unit, contact your distributor or G&L Motion Control. Do this as soon as possible after receipt of the unit.

3.5 Complying with European Directives

For industrial products installed within the European Union or EEC regions, certain directives and standards apply. See "Conformity" in the Specifications sections of Chapters 5 and 6 for applicable directives.

Servo amplifiers are considered to be subsystems when incorporated into electrical plants and machines for industrial use. The G&L Motion Control servo amplifiers have been designed and tested as such. They bear the CE mark and are provided with a Declaration of Conformance. However, it is the overall machine or system design that must meet European Directives and standards. To help the manufacturer of the machine or plant meet these directives and standards, specific guidelines are provided in this documentation. These include such things as shielding, grounding, filters, treatment of connectors and cable layout.

3.6 Conforming with UL and cUL Standards

G&L Motion Control drives meet safety and fire hazard requirements as outlined in "Conformity" in the Specifications sections of Chapters 5 and 6.

3.7 General Installation and Ventilation Requirements

- The drive must be enclosed in a grounded NEMA12 enclosure offering protection to IP55 such that they are not accessible to an operator or unskilled person, in order to comply with UL[®] and CE requirements. A NEMA 4X enclosure exceeds these requirements providing protection to IP66.
- The environmental conditions must not exceed those detailed in the specifications tables shown in the Specifications sections in this manual.
- Install the panel on a properly bonded, flat, rigid, non-painted galvanized steel, vertical surface that won't be subjected to shock, vibration, moisture, oil mist, dust, or corrosive vapors.

- Maintain minimum clearances for proper airflow, easy module access, and proper cable bend radius.
- Plan the installation of your system so that you can perform all cutting, drilling, tapping, and welding with the drive removed from the enclosure. Because the drive is of the open type construction, be careful to keep any metal debris from falling into it. Metal debris or other foreign matter can become lodged in the circuitry, which can result in damage to components.

The MMC Smart Drive is suitable for operation in a pollution degree 2 environment (i.e., normally, only non-conductive pollution occurs). Install the drive away from all sources of strong electromagnetic noise. Such noise can interfere with MMC Smart Drive operation.

Protect the MMC Smart Drive system from all the following:

- conductive fluids and particles
- corrosive atmosphere
- explosive atmosphere

Diagrams included with this manual and recommendations may be modified if necessary so the wiring conforms to current NEC standards or government regulations.

Table 3-1: Cabinet Clearance Dimensions

Location	Minimum Clearance	
	230V Drive	460V Drive
Above Drive Body	2.0 in. (50.8 mm)	4.0 in. (100 mm)
Below Drive Body	2.0 in. (50.8 mm)	4.0 in. (100 mm)
Each Side of Drive	.50 in. (12.7 mm)	None
In Front of Drive (for cabling)	3.0 in. (76.2 mm)	3.0 in. (76.2 mm)

NOTE

Use filtered or conditioned air in ventilated cabinets. The air should be free of oil, corrosives, or electrically conductive contaminants.

3.8 Controlling Heat Within the System

The MMC Smart Drive hardware case is designed to promote air circulation and dissipate heat. Normally no fans or air conditioners are needed.

However, if the environment outside the control cabinet is hot or humid, you may need to use a fan, heat exchanger, dehumidifier or air conditioner to provide the correct operating environment.

Make sure that the temperature and humidity within the drive cabinet does not exceed that which is shown in the specifications sections of this manual.

Make sure that components installed in the cabinet with the MMC Smart Drive do not raise the temperature above system limits and that any hot spots do not exceed specifications. For example, when heat-generating components such as transformers, other drives or motor controls are installed, separate them from the drive by doing one of the following:

- Place them near the top of the control cabinet so their heat output rises away from the MMC Smart Drive.
- Put them in another control cabinet above or to one side of the cabinet with the MMC Smart Drive. This protects the MMC Smart Drive from both heat and electrical noise.

The MMC Smart Drive itself is a source of heat, though in most installations its heat dissipates without harmful effects. System heat is generated from power dissipated by:

- the drive
- field side input/output components
- other drives in the cabinet
- the logic power supply
- external shunt resistors
- line reactors

CAUTION

If the MMC Smart Drive is operated outside the recommended environmental limits, it may be damaged. This will void the warranty.

3.9 Bonding

Connecting metal chassis, assemblies, frames, shields and enclosures to reduce the effects of electromagnetic interference (EMI) is the process of bonding.

Most paints act as insulators. To achieve a good bond between system components, surfaces need to be paint-free or metal plated. Bonding metal surfaces creates a low-impedance exit path for high-frequency energy. Improper bonding blocks this direct exit path and allows high-frequency energy to travel elsewhere in the cabinet. Excessive high-frequency energy can negatively affect the operation of the drive.

3.9.1 Bonding a Subpanel Using a Stud

1. Weld threaded mounting studs to the back of the enclosure.
2. Brush off any non-conductive materials (e.g. paint) from the studs.
3. Remove any non-conductive materials from the front of the subpanel.
4. Position the mounting holes on the subpanel over the mounting studs on the back of the enclosure and slide the subpanel onto the studs.
5. Attach the subpanel to the mounting stud by sliding a star washer over the stud and then turn and tighten a nut onto the stud.

3.9.2 Bonding a Ground Bus Using a Stud

1. Weld threaded mounting studs to the back of the subpanel.
2. Brush off any non-conductive materials (e.g. paint) from the studs.
3. Slide a flat washer over the studs.
4. Remove any non-conductive materials from around the mounting hole on the chassis mounting bracket or ground bus.
5. Position the mounting hole of the chassis or ground bus over the studs on the back of the subpanel and slide the mounting bracket or ground bus onto the stud.
6. Attach the subpanel to the subpanel stud by sliding a star washer and then a flat washer over the stud. Turn and tighten a nut onto the stud.

3.9.3 Bonding a Ground Bus or Chassis Using a Bolt

1. Brush off any non-conductive materials (e.g. paint) from the threaded bolt (s).
2. Slide a star washer over the threaded bolt (s).
3. Use a subpanel having tapped mounting holes. Remove any non-conductive materials from around the mounting holes on both sides of the subpanel.
4. Turn the threaded bolts into the subpanel mounting holes.
5. Slide a star washer onto the threaded end of the bolt.
6. Turn and tighten a nut onto the stud.
7. Slide a flat washer onto the threaded end of the bolt.
8. Position the mounting holes on the groundbus or mounting bracket over the threaded bolts and turn the bolts until they come through the grounding bus or mounting bracket.
9. Slide a star washer onto the threaded end of the bolt.
10. Slide a flat washer onto the threaded end of the bolt.
11. Turn and tighten a nut onto the bolt.

3.9.4 Grounding Multiple Drive Cabinets

1. Mount one bonded ground bus in each cabinet.
2. Designate the cabinet ground bus in one and only one of the cabinets as the common ground bus for all of the cabinets in the system.
3. Connect the ground wires from the ground bus in each individual cabinet ground bus to the designated common ground bus (mounted in only one of the cabinets).
4. Connect the common cabinet ground bus to an external ground system that is connected to a single point ground.

3.9.5 Bonding Multiple Subpanels

G&L Motion Control recommends bonding both the top and bottom of subpanels sharing the same enclosure. Use a 25.4 mm (1.0 in.) x 6.35 mm (0.25) wire braid. Be sure the area around each wire braid fastener is clear of any non-conductive materials. Bond the cabinet ground bus to at least one of the subpanels.

NOTE

Subpanels that are not bonded together may not share a common low impedance path. This difference in impedance may affect networks and other devices that span multiple panels.

3.10 Drive Mounting Guidelines

- A control cabinet for the MMC Smart Drive should have a NEMA-12 rating or better. A cabinet with this rating protects its contents from dust and mechanical damage.
- The cabinet must be large enough to provide adequate air circulation for the MMC Smart Drive and other components. Always allow for adequate air flow through the MMC Smart Drive vents.
- The cabinet must have a rigid non-painted galvanized metal surface to mount the MMC Smart Drive on.
- The cabinet door should open fully for easy access.

IMPORTANT

Post warnings according to National, State, or local codes for the voltage present in the control cabinet. Diagrams included with this manual and recommendations may be modified if necessary so the wiring conforms to current NEC standards or government regulations.

NOTE

This drive contains parts and assemblies that are sensitive to ESD (Electrostatic Discharge). Follow static control precautions during installation, testing, service, or repair of this assembly. Parts and assemblies can be damaged if proper precautions are not taken.

1. Lay out the positions for the drive and accessories in the enclosure.
2. Attach the drive to the cabinet, first using the upper mounting slots of the drive and then the lower. The recommended mounting hardware is M5 metric(#10-32).
3. Tighten all mounting fasteners.

3.11 Drive System Grounding Procedures

The ground of the MMC Smart Drive power source must be connected directly to a **Single Point Ground (SPG)** tie block. The tie block should be made of brass or copper, bolted or brazed to the control cabinet. If the tie block is bolted rather than brazed, scrape away paint or grease at the point of contact. Put star washers between the tie block and the cabinet to ensure good electrical contact.

Metal enclosures of power supplies, drives, etc., should also have good electrical contact with the SPG.

CAUTION

The Single Point Ground should be the only common point for all the ground lines. If not, ground loops may cause current flow among components of the system which can interfere with proper operation of the MMC Smart Drive.

Devices to be connected directly to the Single Point Ground include:

- Plant safety ground.
- Protective earth ground(s) from the MMC Smart Drive power terminals.
- The metal panel or cabinet on which the MMC Smart Drive is mounted.
- "Common" or "0 V" lines from power supplies that provide +24 power to devices and external power to the I/O modules and the devices to which they are connected.
- Protective grounds from the devices themselves, such as device drivers, machinery, and operator interface devices.
- Protective earth ground from line and load sides of any AC line filters.
- The ground of the power source of the computer workstation or laptop, if any, from which you monitor the system operation. An AC outlet in the control cabinet is recommended.
- Single point grounds from other control cabinets, if any, in the system.

IMPORTANT

You must ensure that the "0V" or "Common" of all devices connected to the MMC Smart Drive are connected to Single Point Ground (SPG). Failure to do so may result in erratic operation or damage to the MMC Smart Drive and devices connected to it. Examples of devices connected to the MMC Smart Drive include the power source that supplies power to the MMC Smart Drive and devices connected to the MMC Smart Drive PiCPro Port. Note that some devices (for example, a Personal Computer) may have their "0V" and "Protective Earth Ground" connected together internally, in which case only one connection has to be made to SPG for that device. Also note that the AC/DC converter for some portable PCs have chassis connected from the wall plug to the PC. The ground for the AC outlet must be connected to the SPG.

Also, you must ensure that the MMC Smart Drive "Protective Earth Ground" connection is connected to SPG, and that the MMC Smart Drive is mounted to a metal panel or enclosure that is connected to SPG.

3.11.1 Grounding Requirements

Figure 3-1: Example of Grounding Required for CE Compliant Single Phase 230V Drive System

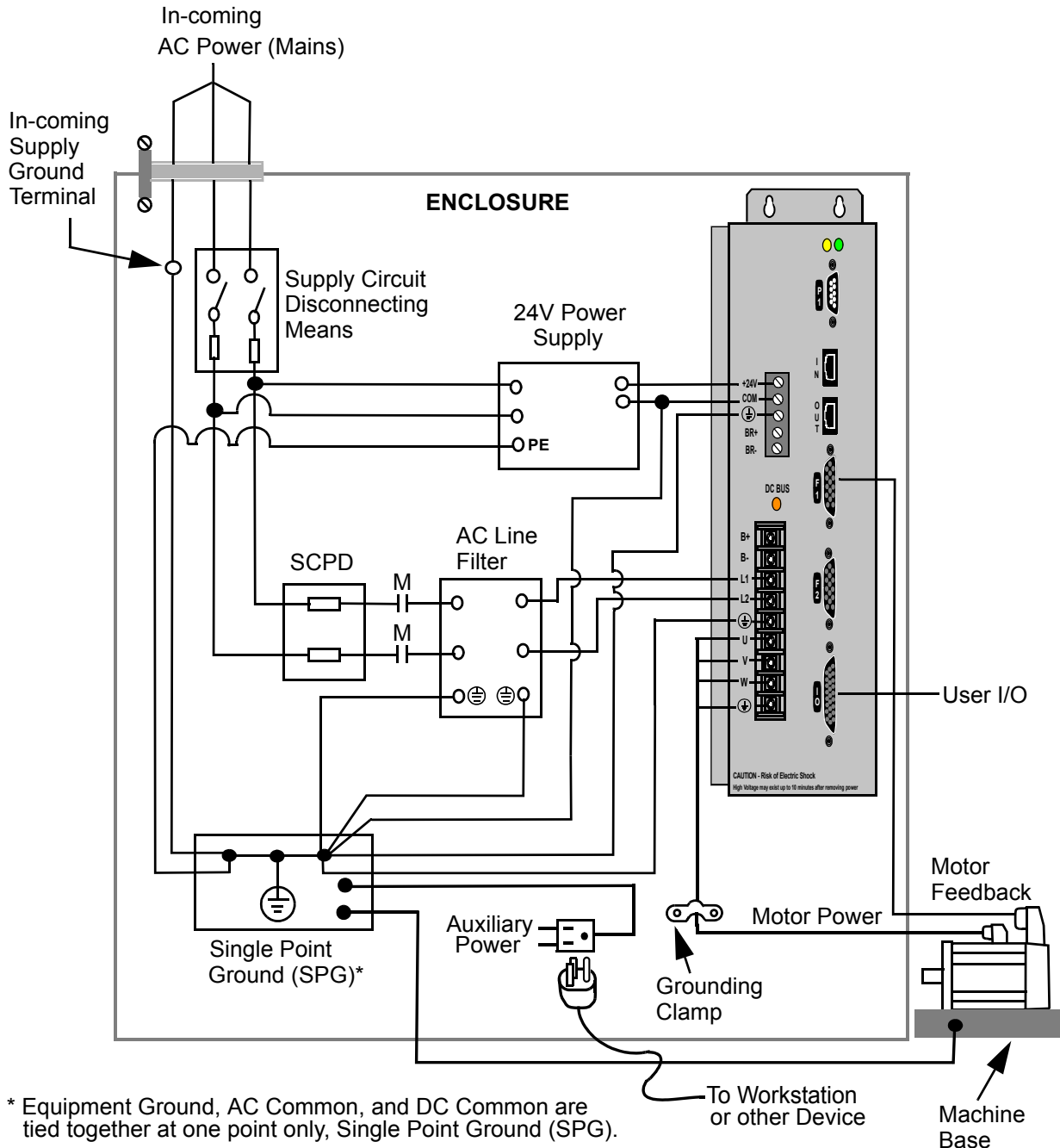

1. Mount the filter as close to the Drive as possible. If the distance exceeds 600 mm (2.0 ft), use shielded cable between the Drive and the filter, strapping the shield to chassis at each end of the cable. This is particularly important for attenuation of higher frequency emissions (5-30 MHz).

2. Shield or separate the wires connecting the AC power to the filter from other power cables (e.g., connections between the Drive and the filter, motor power cable, etc.). If the connections are not separated from each other, the EMI on the Drive side of the filter can couple over to the source side of the filter, thereby reducing or eliminating the filter's effectiveness. The coupling mechanism can radiate or allow stray capacitance between the wires.
3. Bond the filter and the Drive to a grounded conductive surface (the enclosure) to establish a high frequency (HF) connection. To achieve the HF ground, the contact surface interface between the filter, Drive, and the enclosure should be free from paint or any other type of insulator.
4. Size the filter following manufacturer recommendations.
5. Provide a large enough ground bar to connect all wires with no more than two wires per connection.
6. Clamp motor power cable shield for EMC termination.

IMPORTANT

Filter AC power to the drives to be compliant to CE emission requirements.

WARNING

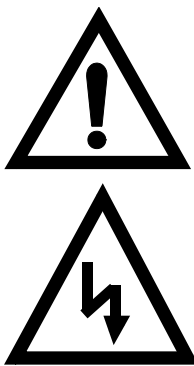

High voltage exists in AC line filters. The filter must be grounded properly before applying power. Filter capacitors retain high voltages after power removal. Before handling the equipment, voltages should be measured to determine safe levels. Failure to observe this precaution could result in personal injury.

3.11.2 Grounding Multiple Drives in the Same Cabinet

1. Mount a common bonded ground bus in the cabinet.
2. Connect the ground wires for all drives to the common bonded cabinet ground bus.
3. Connect the common bonded cabinet ground bus to an external ground system that is connected to a single point ground.

3.12 System Wiring Guidelines

The MMC Smart Drive relies on electrical signals to report what is going on in the application and to send commands to it. In addition, signals are constantly being exchanged within the system. The MMC Smart Drive is designed for use in industrial environments, but some guidelines should be followed.

This section contains common system wiring configurations, size, and practices that can be used in a majority of applications. National Electrical Code, local electrical codes, special operating temperatures, duty cycles, or system configurations take precedence over the values and methods provided.

Wherever possible, install wiring and related components in the following order:

1. main power line disconnecting means
2. transformer (optional)
3. fuses (SCPD)
4. motor control
5. line reactor (as required)
6. line filter (optional)
7. device protection fuses (as required)
8. drive
9. shunt resistors (optional)

3.12.1 Recommended Signal Separation

G&L Motion Control recommends separation of low level signals (encoder, analog, communications, fast DC inputs) from high voltage or high current lines. Maintain at least two inches of separation.

Inside a control cabinet, connect the shields of shielded cables at the MMC Smart Drive. It is recommended that factory cables (from G&L Motion Control) are used between MMC drives, controls, and motors to ensure CE compliance.

WARNING	
	Use care when wiring I/O devices to the MMC Smart Drive and when plugging in cables. Wiring the wrong device to the connector or plugging a connector into the wrong location could cause intermittent or incorrect machine operation or damage to equipment.

Figure 3-2: Recommended Signal Separation



To prevent excessive conducted emissions from a DC power source (typically 24V) used for digital I/O, a .001 micro farad capacitor should be used. Connect the capacitor from the +24V DC to COMMON at the distribution terminals.

3.12.2 Building Your Own Cables

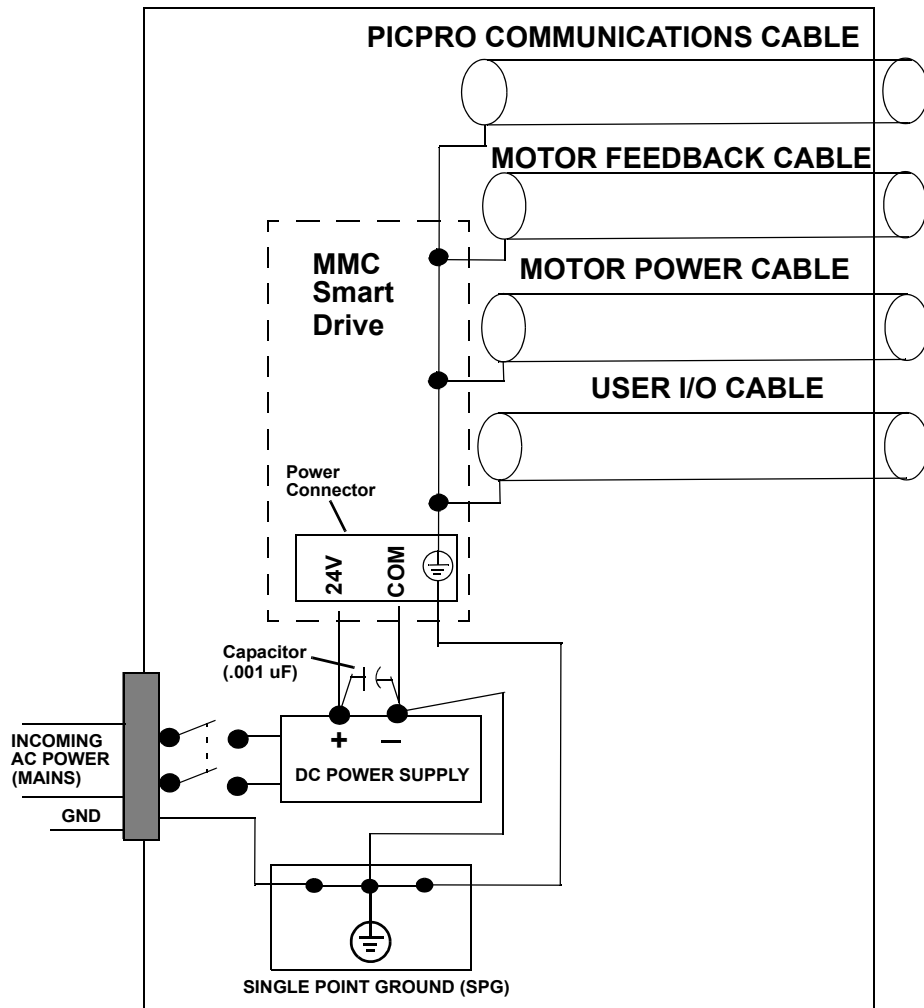
- Connect the cable shield to the connector shells on both ends of the cable for a complete 360 degree connection.
- Use a twisted pair cable whenever possible, twisting differential signals with each other, and single-ended signals with the appropriate ground return.

NOTE

G & L Motion Control Inc. cables are designed to minimize EMI and are recommended over hand-built cables.

3.12.3 Routing Cables

Guidelines for routing cables in a cabinet include the following:

- Always route power and control cables separately.
- Do not run high and low voltage wires/cable in the same wireway.
- Cross high and low voltage conductors at 90 degree angles.
- On parallel cable runs, maximize the distance between high and low voltage cables.
- Maintain the least amount of unshielded cable leads.

3.13 Wiring the Drive

These procedures assume you have bonded and mounted your MMC Smart Drive to the subpanel and that there is no power applied to the system.

3.13.1 Sizing the 24V Power Supply

When you size your power supply, you must ensure that the supply is large enough to handle the total load. Refer to the specification tables for the +24VDC input power requirements.

In most cases, one power supply can be used for an entire control system. However, depending upon the drives and external I/O used in the application, the power distribution may be split into two or more power supplies.

Use of switches in series with the 24VDC power input is not recommended. The drive contains energy storage capacitors at the inputs. While no harm is done to the drive, this much capacitance across the 24VDC source may cause voltage dips when the switch in series with the 24VDC power is closed.

CAUTION

A possible ignition hazard within the MMC Smart Drive exists if excessive current is drawn from the 24 VDC powering the MMC Smart Drive. To prevent this possibility (due to improper wiring or 24 VDC supply failure), a fuse should be used in series with the 24 VDC to the MMC Smart Drive. Specifically, a 4 A max. "UL248 Series" fuse should be used. In addition, the 24 VDC shall be supplied by an isolating source such that the maximum open circuit voltage available to the MMC Smart Drive is not more than 30 VDC.

The +24V power to the MMC Smart Drive is connected through a Phoenix 5-pin connector with a plug-in terminal block. The ground from the power source and the ground from the MMC Smart Drive must be connected to the Single-Point Ground (SPG). Devices connected to the User I/O Port may have their own power sources for input or output control signals provided that each one is:

- at the correct voltage and current levels for the module and the device.
- connected to the same Single-Point Ground that the MMC Smart Drive uses.

It is recommended that the same main disconnect switch be used for the MMC Smart Drive and for all devices in the application.

IMPORTANT

No matter how the system is installed, before you connect the MMC Smart Drive to the application, make sure that power is off to the system and to the devices that are wired to the MMC Smart Drive.

3.13.2 System AC Power Wiring Guidelines

NOTE

In addition to the guidelines listed below, follow all national and local electrical codes and regulations.

- Install a supply circuit disconnecting means.
- Install a Short Circuit Protective Device (SCPD).
- Due to high inrush current at power-up, use dual element time delay fuses for the SCPD.
- Install additional device protection fusing (460V models). Only high speed type fuses provide proper protection.
- Refer to the Specifications sections in Chapter 4 of this manual for device and conductor requirements.
- Clamp the motor power cable shield to the drive using the G&L Motion Control supplied bracket. Maximum tightening torque for bracket screws is 10 lb-in.
- Use shielded cables and AC line filters (for CE Compliance). Make sure that wiring from the drive to the line filter is as short as possible. Locate common grounding bus bars as close as possible to the drive. The braid shield of the cable should be clamped at the drive or mounting panel.
- Power connections for each drive in a system should be separately connected directly to the AC power supply. Do not daisy chain drive power connections.
- Make sure the phase to neutral ground voltage does not exceed the input ratings of the drive when using an autotransformer.

3.13.3 Connecting Interface Cables

IMPORTANT

This drive contains ESD (Electrostatic Discharge) sensitive parts and assemblies. Follow static control precautions when installing, testing, servicing, or repairing components in a drive system.

- Plug the 9-pin D-shell, serial PiCPro cable into the PiCPro port.
- Plug the one 15-pin D-shell, Feedback cable into the FBK1 connector.
- Plug the 26-pin D-shell, User I/O cable into the I/O connector.
- Tighten the attachment screws for all cables to the drive connectors.

WARNING



To avoid personal injury and/or equipment damage:

- Ensure installation complies with specifications regarding wire types, conductor sizes, branch circuit protection, and disconnect devices. The National Electrical Code (NEC) and local codes outline provisions for safely installing electrical equipment.
- Ensure motor power connectors are used for connection purposes only. Do not use them to turn the unit on and off.
- To avoid personal injury and/or equipment damage, ensure shielded power cables are grounded to prevent potentially high voltages on the shield.

3.13.4 Preparing Motor Connection Wires

NOTE

It is recommended that G & L Motion Control Inc. cables be used. G & L Motion Control Inc. cables are designed to minimize EMI and are recommended over hand-built cables.

1. Strip back cable jacket approximately 152 mm (6.0 in.) from the end of the cable.
2. Strip approximately 12 mm (0.50 in.) of insulation from the end of each conductor. Do not tin ends after stripping.

IMPORTANT

Do not nick, cut or damage wire strands while removing wire insulation.

3. Strip the cable jacket away from the cable until the shield braid is visible. Expose 17 mm (0.68 in.) of cable shield braid.

Figure 3-3: : Motor Cable

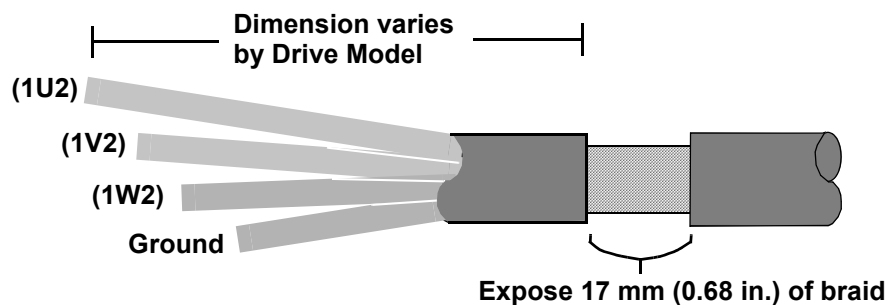

4. Attach the individual wires from the motor cable to their assigned terminal. Refer to Chapters 5 and 6 for front panel connectors and terminal assignments.
5. Tighten each terminal screw.
6. Gently pull on each wire to make sure it does not come out of its terminal. Reinsert and tighten any loose wires.
7. Attach the plastic cover to terminal block

Factory supplied motor power cables for LSM, MSM, FSM, HSM, XSM, YSM and NSM Series motors are shielded, and the power cable is designed to be terminated at the drive during installation. A small portion of the cable jacket is removed which exposes the shield braid. The exposed shield braid must be clamped to the drive chassis using the provided clamp and clamp screws

Figure 3-4: Terminating Motor Power Cable for 230V Drive

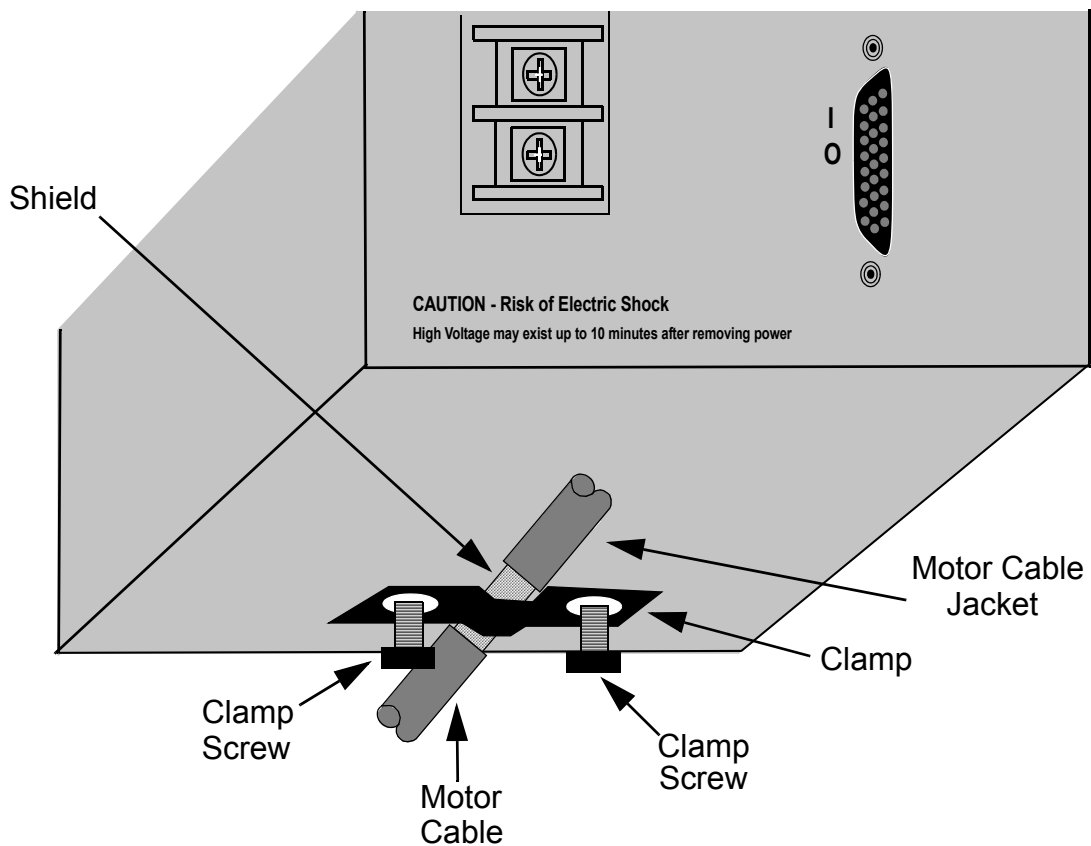
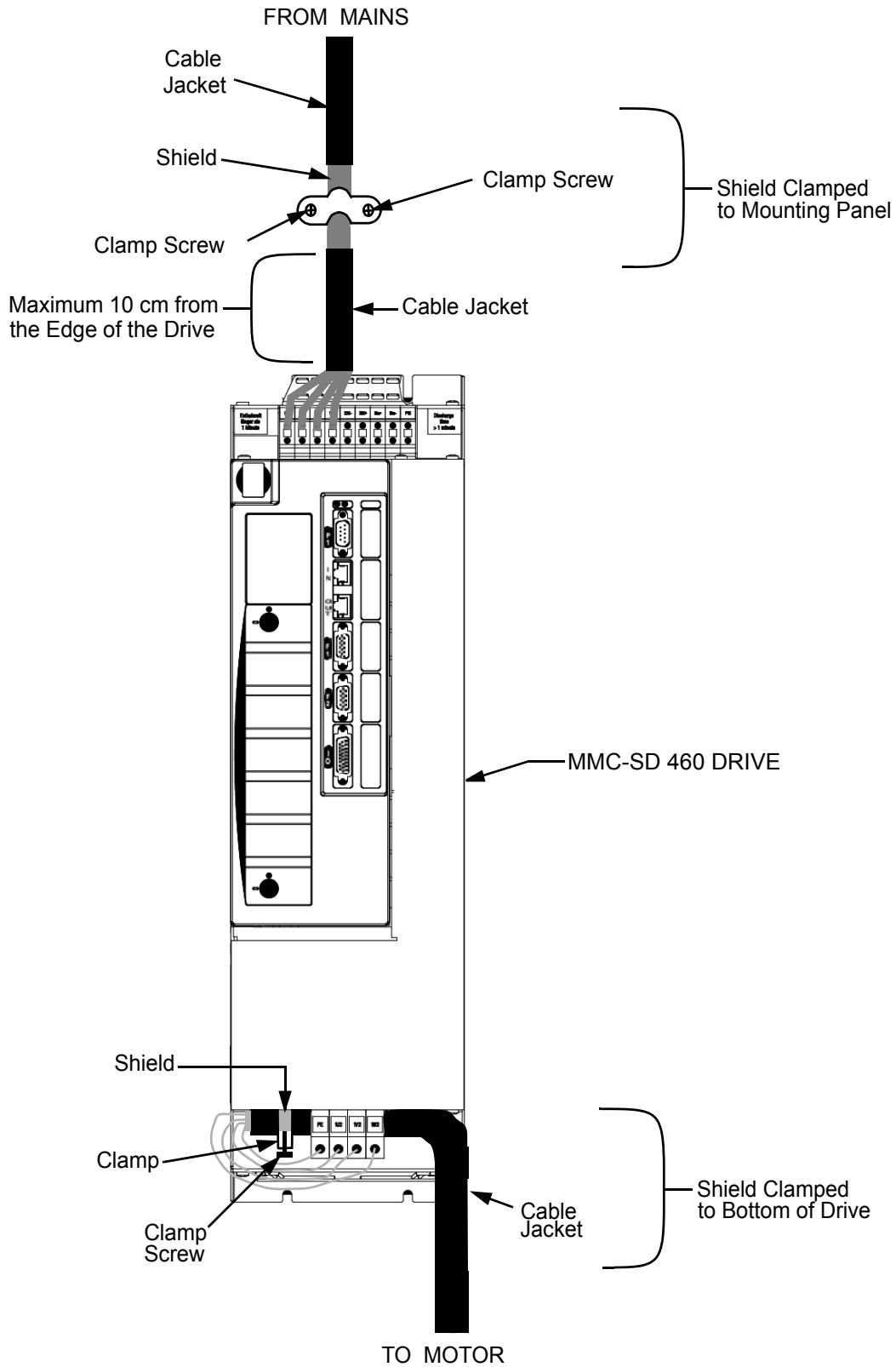

Figure 3-5: Terminating Incoming AC Power (Mains) Cable for 460V Drive



4 System Power Protection and Related Devices

4.1 Motor Overload Protection

The MMC Smart Drive utilizes solid state motor overload protection in accordance with UL508C that operates:

- within 8 minutes at 200% overload
- within 20 seconds at 600% overload

4.2 Fuses

4.2.1 Fuse Sizing

Branch Circuit Protection must be provided for the MMC Smart Drive in accordance with NFPA 79 7.2.3 and 7.2.10. Bussmann or equivalent Class RK1, J, or CC dual element time delay type fuses should be used as the branch circuit SCPD (Short Circuit Protection Device). Supplemental UL1007 protectors shall not be used to provide Branch Circuit Protection. Fuses are sized based on the drive input current rating and maximum SCPD rating designations shown in NFPA 79 Table 7.2.10.1. Input mains conductor size is based on designations shown in NFPA Table 7.2.10.4 and 13.5.1.

Table 4-1: AC Input Power Requirements

Drive Model	Requirements			
	Nominal Input Current (Amps _{RMS})	Branch Circuit Fuse (Amps)	Conductor (AWG)	Transformer (kVA)*
MMC-SD-0.5-230	5	12	14	1
MMC-SD-1.0-230	9	15	14	2
MMC-SD-2.0-230	18	30	14	4
MMC-SD-1.3-460	2.44	4	14	1.94
MMC-SD-2.4-460	4.18	7	14	3.33
MMC-SD-4.0-460	7	12	14	5.6
MMC-SD-6.0-460	10.8	17.5	14	8.6
MMC-SD-8.0-460	14.8	25	12	11.8
MMC-SD-12.0-460	16.7	25	12	13.3
MMC-SD-16.0-460	21.1	35	10	16.8
MMC-SD-24.0-460	33.1	50	8	26.3

* See Section 4.5 for calculating application transformer requirements.

Table 4-2: NFPA 79 Table 7.2.10.1 (Extraction)

Fuse Class with Time Delay	Full Load Current (%)
	AC-2
RK-1	150
J	150
CC	150

Table 4-3: NFPA 79 Table 7.2.10.4 (Extraction)

Conductor Size (AWG)	Maximum Rating
	Time Delay-Dual Element Fuse (amps)
14	30
12	40
10	50
8	80
6	100

4.2.2 Device Protection

To comply with UL508C, additional device protection is required for the MMC-SD 460V model drives. High Speed (semiconductor) type fuses must be applied in series with the Branch Circuit protection and wired directly before the drive input mains. Reference Figure 4-9 on page 54.

Table 4-4 on page 40 lists the maximum I^2t allowed for each drive. Table 4-5 on page 41 provides a list of Bussman High Speed fuses that meet these requirements.

Table 4-4: Device Protection

Drive Model *	Maximum Load Value ¹⁾
MMC-SD-1.3-460	$\leq 310A^2s$
MMC-SD-2.4-460	$\leq 310A^2s$
MMC-SD-4.0-460	$\leq 450A^2s$
MMC-SD-6.0-460	$\leq 450A^2s$
MMC-SD-8.0-460	$\leq 450A^2s$
MMC-SD-12.0-460	$\leq 1,500A^2s$
MMC-SD-16.0-460	$\leq 1,500A^2s$
MMC-SD-24.0-460	$\leq 1,500A^2s$

* Drive Model pertains to Analog (no dash suffix) and Digital (-D)

¹⁾ Use fuses that fall in the operating point below the stated release integral (I^2t)

Table 4-5: Fuses for Device Protection

Drive Model *	High Speed Device Protection Fuse	
MMC-SD-1.3-460	25A / 690V	Bussmann 170M1561
MMC-SD-2.4-460	25A / 690V	Bussmann 170M1561
MMC-SD-4.0-460	25A / 690V	Bussmann 170M1561
MMC-SD-6.0-460	25A / 690V	Bussmann 170M1561
MMC-SD-8.0-460	40A / 690V	Bussmann 170M1563
MMC-SD-12.0-460	63A / 690V	Bussmann 170M1565
MMC-SD-16.0-460	63A / 690V	Bussmann 170M1565
MMC-SD-24.0-460	80A / 690V	Bussmann 170M3811

* Drive Model pertains to Analog (no dash suffix) and Digital (-D)

NOTE
Fuses from other manufacturers can be used if they meet the requirements in Figure 4-4 on page 40. The approved fuses in Table 4-5 are UL recognized.

4.3 Short Circuit Protection

Table 4-6: Motor Short Circuit Protection Ratings

Drive	Short Circuit Current Rating with No Fuse Restrictions	Short Circuit Current Rating with Fuse Restrictions
230V Drives	Suitable for use on a circuit capable of delivering not more than 5000 RMS symmetrical short circuit Amperes, 240 Volts maximum.	Suitable for use on a circuit capable of delivering not more than 200,000 RMS symmetrical Amperes, 240 Volts maximum, when protected by high interrupting capacity, current limiting fuses as the SCPD (Fuse Class RK-1, J, or CC).
460V Drives	Suitable for use on a circuit capable of delivering not more than 5000 RMS symmetrical short circuit Amperes, 480 Volts maximum.	Suitable for use on a circuit capable of delivering not more than 18,000 RMS symmetrical Amperes, 480 Volts maximum, when protected by high speed (semiconductor) fuses as listed.

4.4 Line Reactors

AC Line Reactors are required when using some models of the MMC Smart Drive. They protect the drive from impermissible rates of current change and reduce harmonic current distortions. When required, they are mounted between the drive and the mains input power source.

NOTE
Multiple drives or inverters on a common power line require one reactor per drive. Individual reactors provide filtering between each drive (and thereby reduce crosstalk) and also provide optimum surge protection for each unit. A single reactor serving several drives does not provide adequate protection, filtering or harmonic reduction when the system is partially loaded. Refer to Figure 4-1 for an example of one line reactor connected to one drive.

WARNING

Danger Electric Shock Risk
The frame of line/load reactors must be grounded at one of the reactor mounting holes typically by using a star washer under the heads of the mounting bolts. INJURY OR DEATH MAY RESULT IF THESE SAFETY PRECAUTIONS ARE NOT OBSERVED.

Figure 4-1: Line Reactor Connection (Simplified)

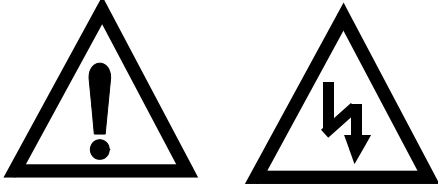
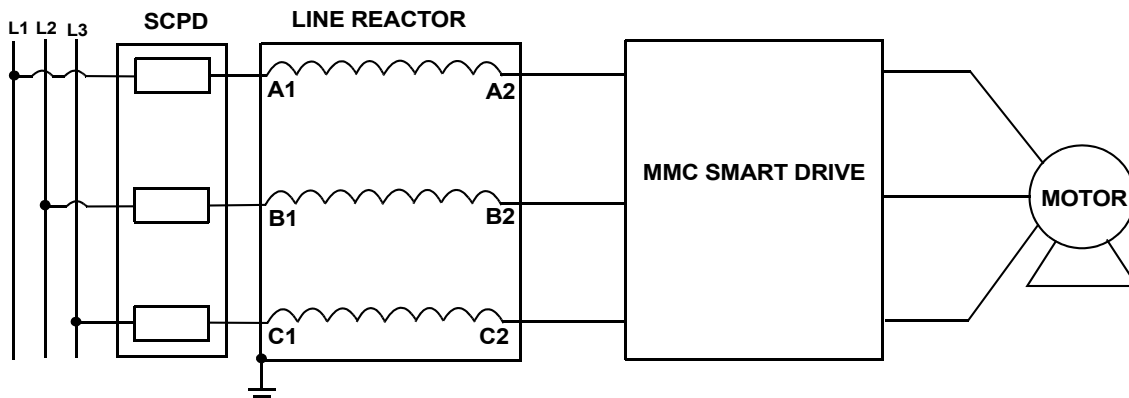

Line reactors are not necessary for the 230V MMC Smart Drives or the 460V size 1 and 2 MMC Smart Drives. Line reactors are required for the 460V size 3 MMC Smart Drives.

4.4.1 Specifications and Dimensions for Required Line Reactors

Table 4-7: MMC-SD-12-460 Line Reactor Specifications				
Fundamental Amperage	Power Loss	Inductance	Weight	Part Number
25A	52W	1.2 mH	14 lbs.	M.1302.7373

Table 4-8: MMC-SD-16-460 Line Reactor Specifications				
Fundamental Amperage	Power Loss	Inductance	Weight	Part Number
35A	54W	0.8 mH	16 lbs.	M.1302.7374

Technical drawing of the MMC-SD-16-460 Line Reactor. The drawing includes three views: a top view, a front view, and a side view. The top view shows a rectangular unit with a central 'LABEL' area. Dimensions include a total width of 3.00, a distance of 2.63 from the left edge to the center of the label, and a maximum height of 4.00. There are four slots on the top surface, each measuring 0.38 x 0.75. The front view shows the reactor core with a maximum height of 5.75 and a maximum width of 7.25. A caution note indicates 'CAUTION - TERMINAL SCREW TIGHTENING TORQUE: 16 in-lb MAX'. The side view shows the unit's profile. Text on the right side of the drawing specifies 'WIRE RANGE: 22-5 AWG'.

Table 4-9: MMC-SD-24-460 Line Reactor Specifications

Fundamental Amperage	Power Loss	Inductance	Weight	Part Number
45A	62W	0.7 mH	28 lbs.	M.1302.7375

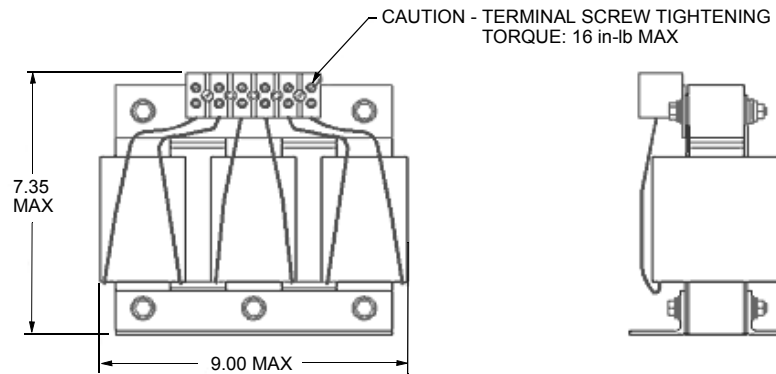
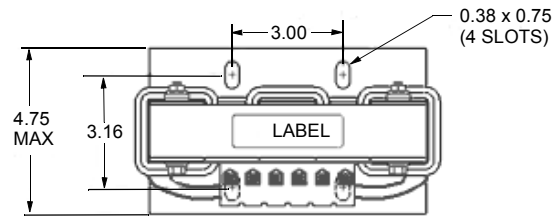

4.5 Isolation Transformers

The MMC Smart Drive does not require the use of isolation transformers. However, a transformer may be required to match the voltage requirements of the controller to the available service. To size a transformer for the main AC power inputs, the power output (KVA) of each axis must be known. This can be derived by calculating the horsepower for each axis and converting that horsepower into units of watts. If power is being supplied to more than one motor and a drive, simply add the kW ratings together from each calculation to get a system kW total.

For an autotransformer, ensure that the phase to neutral/ground voltages do not exceed the input voltage ratings of the drive.

If you are using the Motions Solutions Sizing Software, the average speed and average torque data has already been calculated and can be used in the equation. If you are not sure of the exact speed and torque in your application, record the speed/torque curve for your drive/motor combination and use the resulting values as a worst case continuous speed and torque.

Calculations are multiplied by a factor to compensate for the power and loss elements within a power system. A factor of 2.0 is used with a single phase system and a factor of 1.5 is used with a three phase system. This factor should minimize the effects of the secondary line voltage sagging in the transformer during peak current periods.

The speed/torque curve information for 230V motors is based upon a drive input voltage of 230V AC. For a 115V AC input voltage, the maximum speed can be reduced up to one half.

Example 230V Formula:

$$KVA = \frac{Speed(RPM) \cdot Torque(lb - in)}{63,025} \cdot \frac{0.746 \cdot KVA}{HP} \cdot 2.0$$

Example 460V Formula:

$$KVA = \frac{Speed(RPM) \cdot Torque(lb - in)}{63,025} \cdot \frac{0.746 \cdot KVA}{HP} \cdot 1.5$$

NOTE

The 3-Phase source powering the drive has to be a center-grounded "Y" configuration. Do not exceed 304 Volts RMS from any phase to ground.

4.6 External Shunts

4.6.1 Choosing an External Shunt

Power from the motor is returned to the MMC Smart Drive during motor deceleration. Excessive power may have to be dissipated from the MMC Smart drive when large inertia loads are present. External shunts should be used to avoid excessive bus over voltage faults.

G&L Motion Control recommends you use the Motion Solutions Sizing Software to determine the need for and type of external shunt. However, you may perform the following calculations to choose the external shunt for your application.

1. Obtain the Peak Generating Power for the drive in watts (W).
2. Perform the following calculation:

$$W \times T = \text{Watts/sec or Joules}$$

where:

W is watts from Step 1 above,

T is decel time required by the application

3. Obtain the Absorption Energy in Joules for the drive from the Specifications section of the drive manual.
4. Determine the Peak Shunt Power from the drive that would be delivered to the shunt resistor for your application:
 - (Number calculated in Step 2 above) - (Absorption Energy from the drive Specifications table in either Chapter 5 or 6)
= Watt-seconds
 - (Watt-seconds computed in 5a. above) \div (Decel Time for the application) = Peak Shunt Power in Watts
5. Determine the Continuous Shunt Power that would be delivered to the shunt resistor for this application:
 - (Duty Cycle of Peak or Peak x Decel Time) \div (Total Cycle Time) = Continuous Shunt Power in Watts
6. Choose an external shunt from Figure 4-10 on page 48.

4.6.2 External Shunt Resistor Kits

Table 4-10: Shunt Resistors

For Drive	Shunt Resistor Module	Part Number
MMC-SD-0.5-230 MMC-SD-1.0-230 MMC-SD-2.0-230	100Ω, 300W, 600V, Dynamic	M.1015.7046
MMC-SD-1.3-460 MMC-SD-2.4-460	130Ω, 450W Cont. Power, 5.4kW Peak Power, 820 V, 240 sec. Time Constant, 121 mm x 93 mm x 605 mm	M.1302.7048
MMC-SD-4.0-460	95Ω, 700W Cont. Power, 8kW Peak Power, 820 V, 250 sec. Time Constant, 121 mm x 93 mm x 705 mm	M.1302.7049
MMC-SD-6.0-460 MMC-SD-8.0-460	50Ω, 1400W Cont. Power, 17kW Peak Power, 850V, 250 sec. Time Constant, 130 mm x 182 mm x 710 mm	M.1302.7060
MMC-SD-12.0-460 MMC-SD-16.0-460	25 Ω, 2800W Cont. Power, 32kW Peak Power, 850V, 60 sec. Time Constant, 171 mm x 430 mm x 550 mm	M.1302.7061
MMC-SD-24.0-460	18Ω, 3900W Cont. Power, 70kW Peak Power, 850V, 70 sec. Time Constant, 180 mm x 445 mm x 490 mm	M.1302.7063

4.6.3 Mounting Dimensions for External Shunts

Figure 4-2: Mounting Dimensions for 230V External Shunt (P/N M.1015.7046)

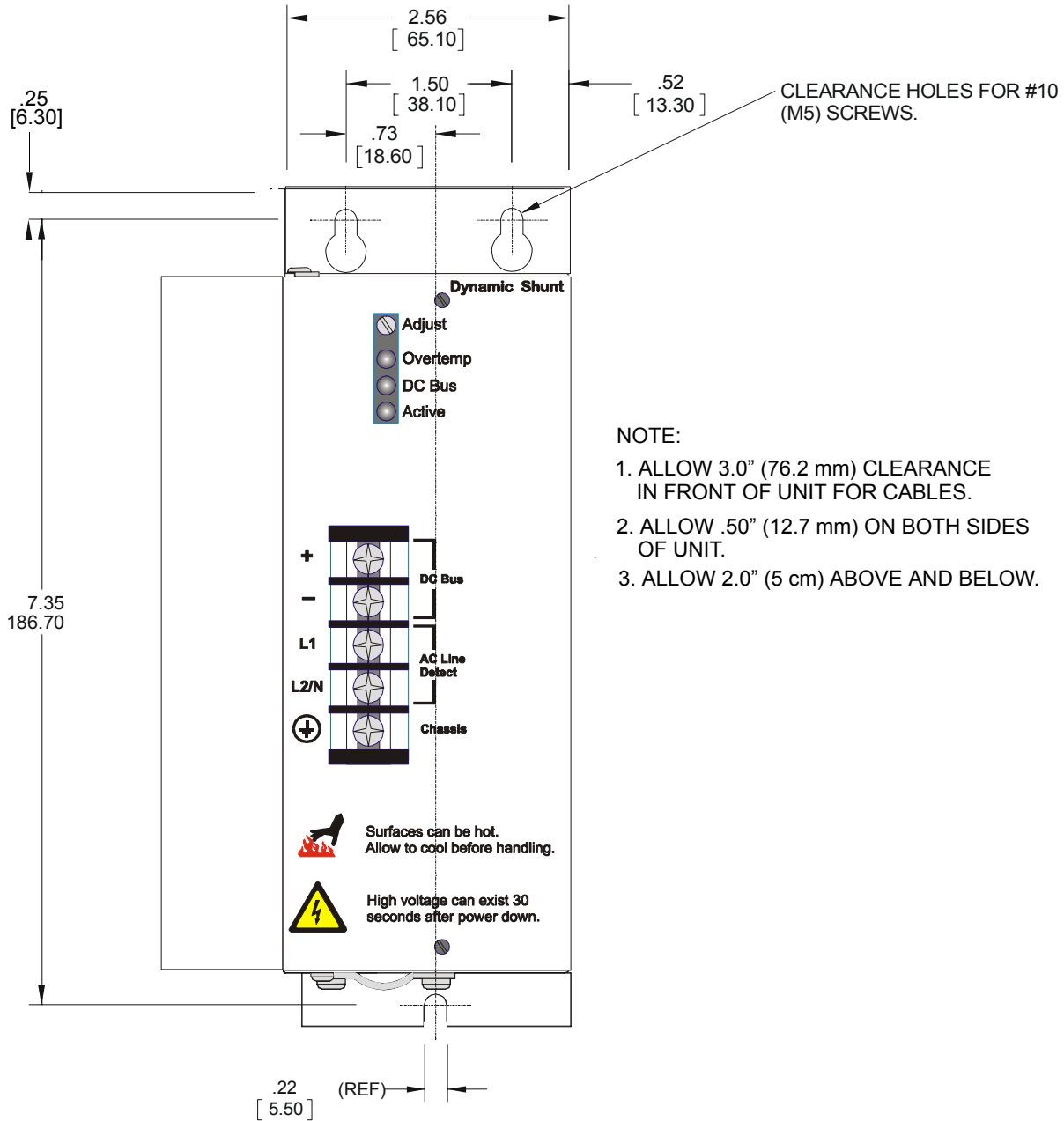

- NOTE:
1. ALLOW 3.0" (76.2 mm) CLEARANCE IN FRONT OF UNIT FOR CABLES.
 2. ALLOW .50" (12.7 mm) ON BOTH SIDES OF UNIT.
 3. ALLOW 2.0" (5 cm) ABOVE AND BELOW.

Figure 4-3: Mounting Dimensions for 460V External Shunt (P/N M.1302.7048)

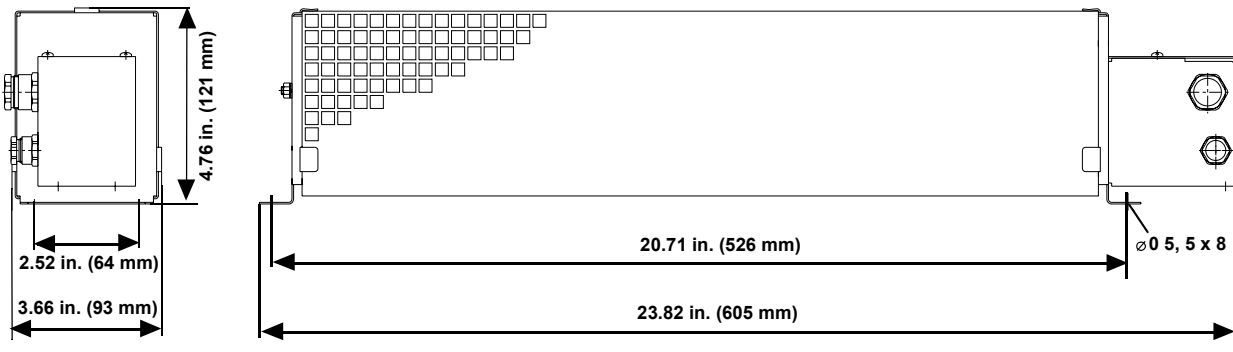

Figure 4-4: Mounting Dimensions for 460V External Shunt (P/N M.1302.7049)

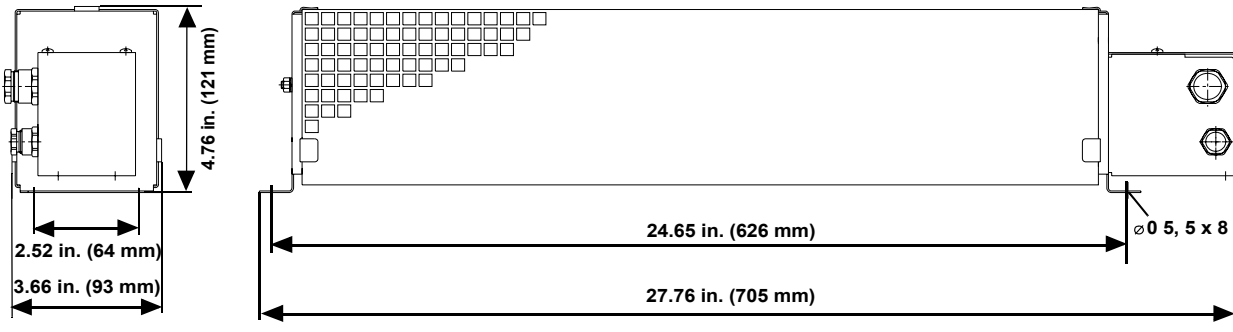

Figure 4-5: Mounting Dimensions for 460V External Shunt (P/N M.1302.7060)

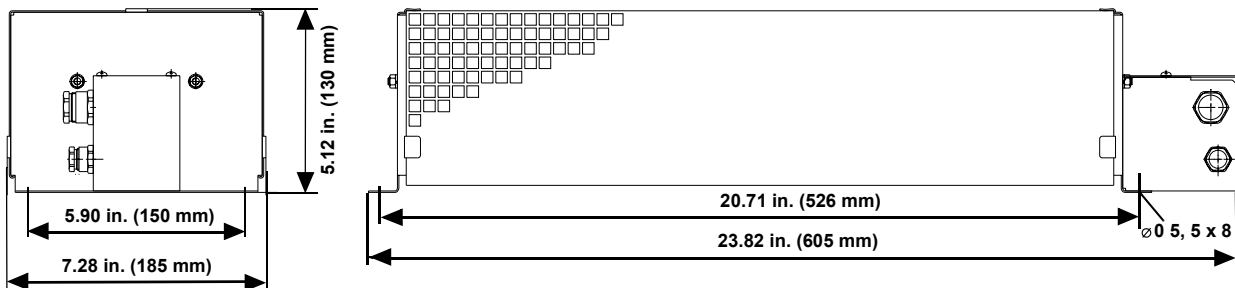

Figure 4-6: Mounting Dimensions for 460V External Shunt (P/N M.1302.7061)

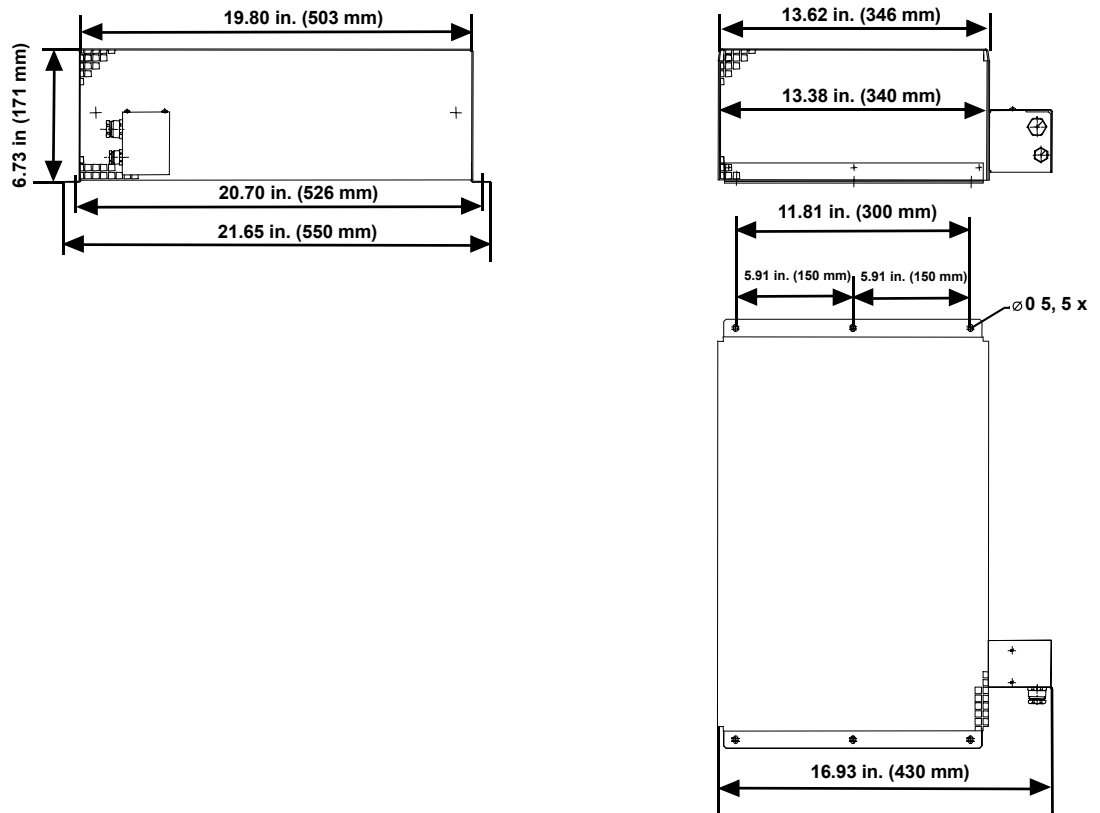
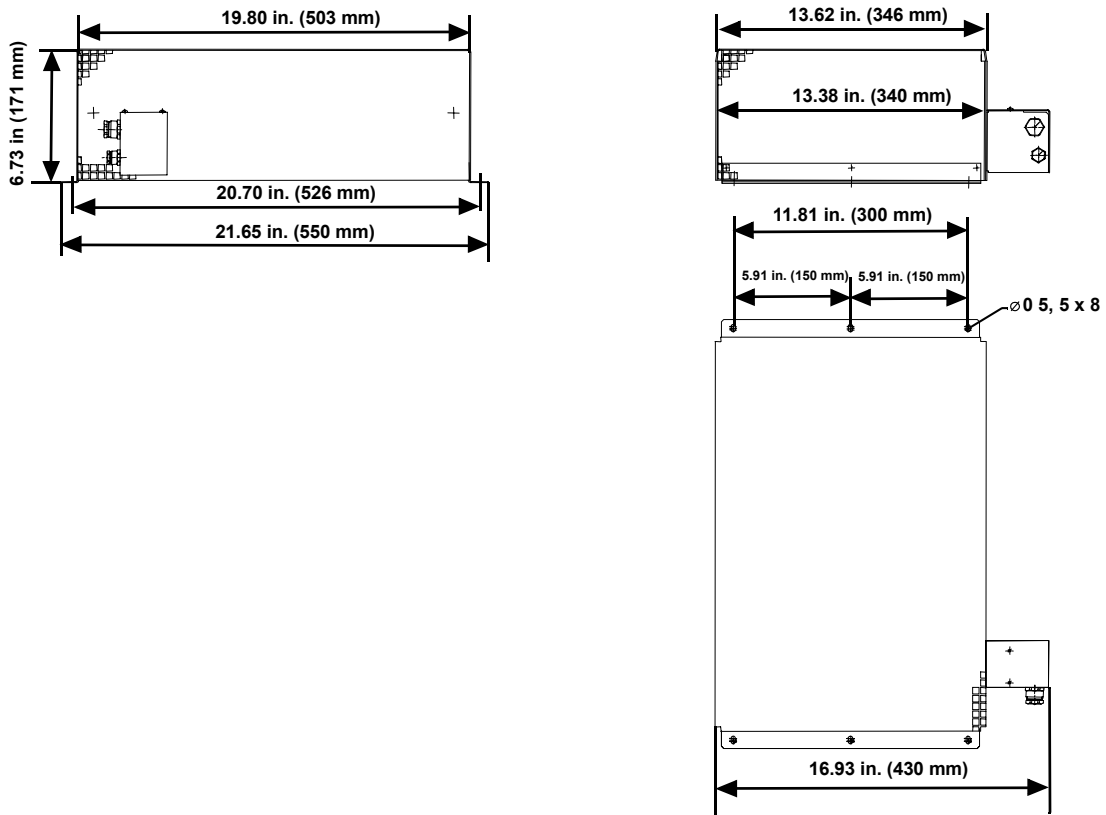

Figure 4-7: Mounting Dimensions for 460V External Shunt (P/N M.1302.7063)



4.7 Line Filters

Line Filters consist of combinations of capacitors, reactors, resistors and voltage limiters that are intended to reduce the electromagnetic influence of the environment.

4.7.1 Line Filters and CE Compliance

The direction of influence is bi-directional, i.e. there is a reaction in the units of emission of conducted disturbances, and, at the same time, an improvement in the immunity of the drive to interference that occurs in the case of lightning strikes, tripped fuses, or simple switching activities.

1. The filter should be mounted to a grounded conductive surface.
2. The filter must be mounted close to the drive input terminals. If the distance exceeds 2 feet (600 mm), then a shielded cable should be used to connect the drive and filter, rather than a wire.
3. The wires connecting the AC source to the filter should be shielded from, or at least separated from the wires (or strap) connecting the drive to the filter. If the connections are not segregated from each other, then the EMI on the drive side of the filter can couple over to the source side of the filter, thereby reducing, or eliminating the filter effectiveness. The coupling mechanism can be radiation, or stray capacitance between the wires. The best method of achieving this is to mount the filter where the AC power enters the enclosure. Figure 4-8 shows a good installation and a poor installation.

Figure 4-8: Block Diagram Simplified for 3-Phase Line Filter

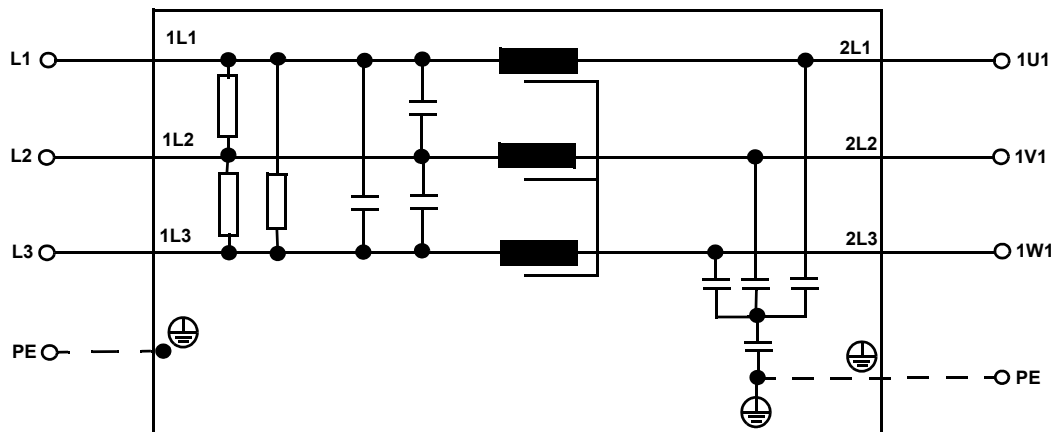
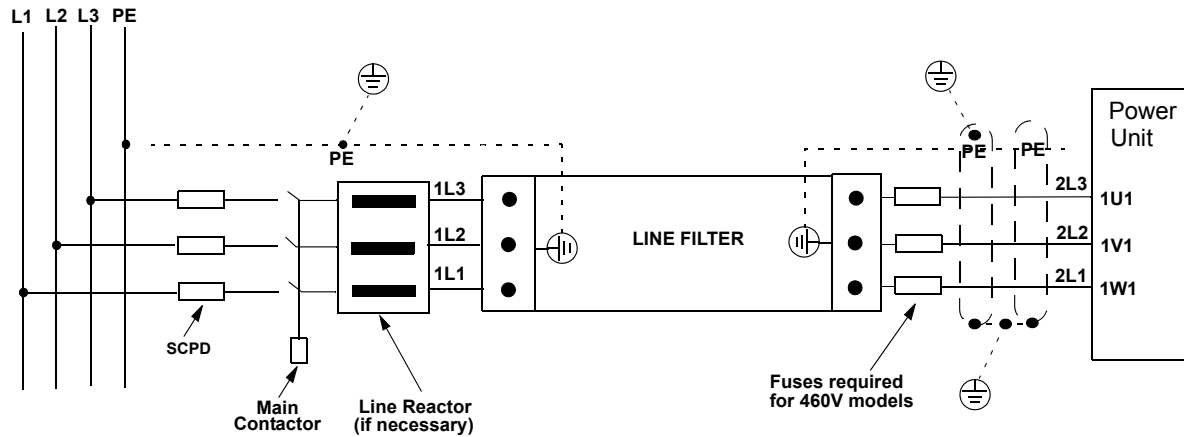



Figure 4-9: Connection Diagram for 3-Phase Line Filter



WARNING	
	<p>High leakage currents exist in AC line filters. The filters must be grounded properly before applying power. Filter capacitors retain high voltages after removal. Measure voltages to determine safe levels prior to handling the equipment. Failure to do so could result in severe bodily injury.</p>

NOTE	
<p>To be able to route the interference currents at low impedance back to the interference sources, the filter, the power unit, and the contact area of the motor cable shield must have a junction with the common mounting plate over as wide a surface as possible that has good conductive properties. The best way to ensure this is to use unpainted zinc-coated mounting plates.</p>	

4.7.2 Part Numbers for AC Line Filters

Table 4-11: Part Numbers for AC Line Filters

Current	For Drive	Part Number
6A, 250V, 1 Phase	MMC-SD-0.5-230 MMC-SD-1.0-230	M.1015.6922
10A, 250V, 1 Phase	MMC-SD-2.0-230	M.1015.6917
7A, 480V, 3 Phase	MMC-SD-1.3-460 MMC-SD-2.4-460	M.1302.5241
16A, 480V, 3 Phase	MMC-SD-4.0-460 MMC-SD-6.0-460 MMC-SD-8.0-460	M.1302.5244
30A, 480V, 3 Phase	MMC-SD-12.0-460 MMC-SD-16.0-460	M.1302.5245
42A, 480V, 3 Phase	MMC-SD-24.0-460	M.1302.5246
56A, 480V, 3 Phase	For filtering multiple drives	M.1302.5247
75A, 480V, 3 Phase	For filtering multiple drives	M.1302.5248

4.8 Technical Data for AC Line Filters

4.8.1 Technical Data for 230V Line Filters

	M.1015.6922	M.1015.6917	M.1015.6918
Voltage/Freq.	250VAC @ 50/50Hz	250VAC @ 50/50Hz	250VAC @ 50/50Hz
Current	6A @ 50°C	10A @ 50°C	23A @ 50°C
Overload Current	150% 1 minute 200% 1 second	150% 1 minute 200% 1 second	150% 1 minute 200% 1 second
Temperature	-25 to 95°C	-25 to 95°C	-25 to 95°C
Leakage Current	5mA @ 240V, 50 Hz	46mA @ 240V, 50 Hz	200mA @ 250V, 50Hz
Electric Strength	2500VAC/1 minute	2500VAC/1 minute	2500VAC/1 minute
Power Loss	3.5W (Full Load)	2.7W (Full Load)	10W (Full Load)
Terminals	2mm sq. spring clamp	M4 screw cross/ sq. 2x 2.5mm	M4 screw cross/ sq. 2x 2.5mm
Weight	0.3Kg (0.66 Lb.)	0.95Kg (2.0 Lb)	1.6Kg (2.5 Lb)
Back Mounting	4 x M4	4 x M4	4 x M4
Side Mounting	2 x M5	2 x M6	2 x M6
Line filters are manufactured to millimeter dimensions (inches are approximate conversions).			

4.8.2 Technical Data for 460V Line Filters

Item	Part Number					
	M.1302.5241	M.1302.5244	M.1302.5245	M.1302.5246	M.1302.5247	M.1302.5248
Maximum Supply Voltage	3 x 480VAC, 50/60Hz					
Rated current (at 40°C)	7A	16A	30A	42A	56A	75A
Peak current	1.5 x I _N for < 1 min. per hour at T _B = 40°					
Test Voltage Phase/Phase Phase/Ground	2.1 kVDC for 2 sec. at 25°C 2.7 kVDC for 2 sec. at 25°C					
Maximum Connection Cross-section	4mm ²	4mm ²	10mm ²	10mm ²	4mm ²	25mm ²
Operational Environmental Temperature Range T _B	-25°C ... +55°C Reduction of rated current from 40°C onwards by 1.4% / °C					
Power Loss (typical)	4W	8W	12W	15W	18W	24W
Site Altitude	Below 2000 m above sea level (higher altitudes on request)					
Storage Temperature Range	-25°C ... +85°C					
Type of Protection	IP20					
Weight	0.6kg	1.0kg	1.3kg	1.6kg	1.9kg	2.6kg

4.8.3 Dimensions for AC Line Filters

4.8.4 230V Line Filter Dimensions

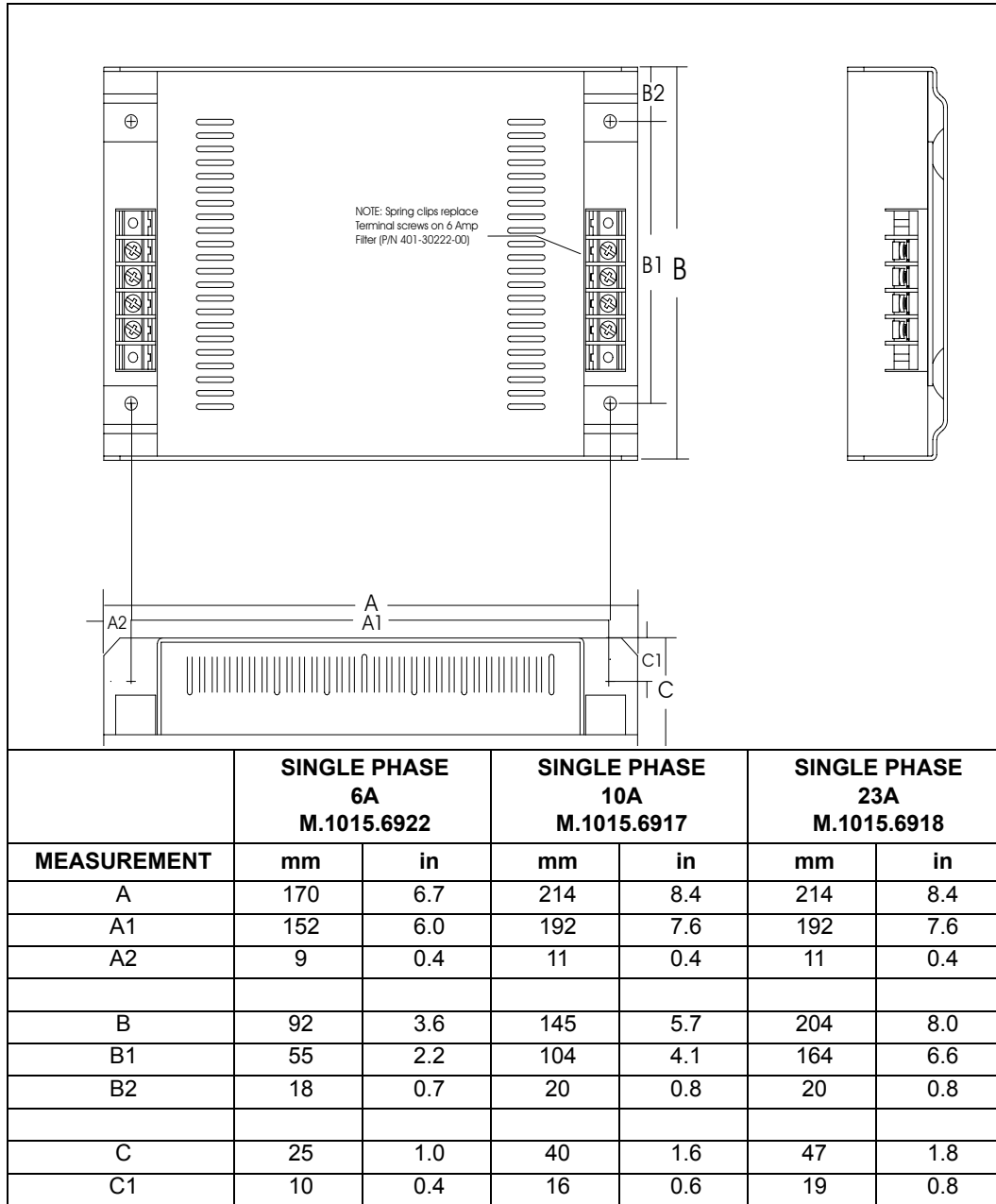

4.8.4.1 460V Line Filter Dimensions

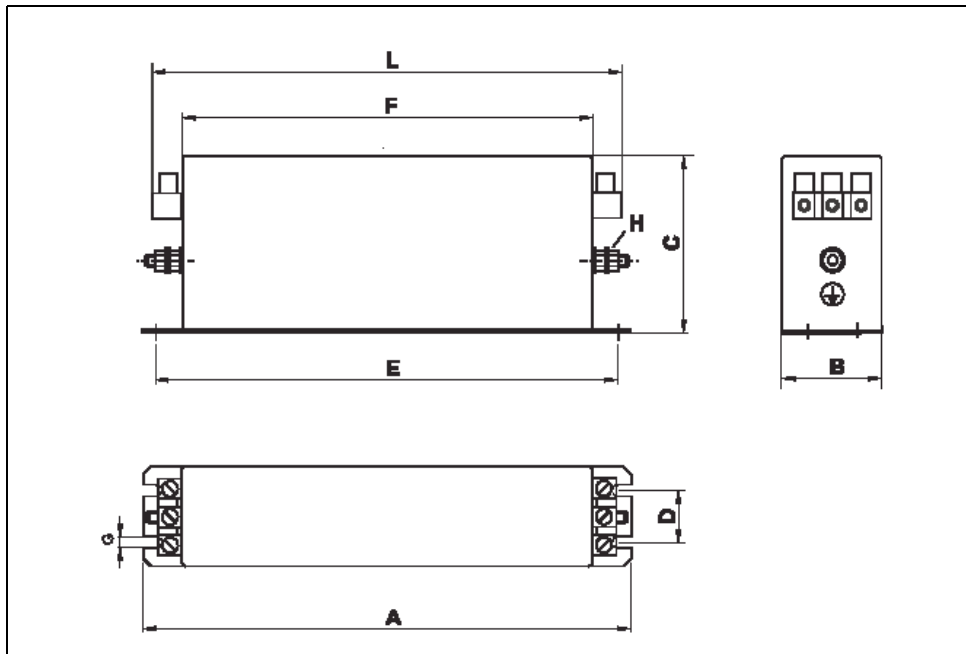

Part Number	A	B	C	D	E	F	L	G	H
M.1302.5241	190	40	70	20	180	160	185	5.4	M5
M.1302.5244	250	50	70	25	235	220	245		
M.1302.5245	270	50	85	30	255	240	265		
M.1302.5246	310	50	85	30	295	280	305	6.5	M6
M.1302.5247	250	85	90	60	235	220	258		
M.1302.5248	270	80	135	60	255	240	278		

5 230V Single Phase MMC Smart Drive

5.1 LEDs

Table 5-1: LEDs Description for 230V Single Phase MMC Smart Drive

LED	Color	Description
P	Green	Power LED. Indicates when illuminated that power is being supplied to the 24V input terminal strip.
D1	Yellow	Status LED. Drive status and fault information.
DC BUS 	Orange	Bus Voltage LED. Indicates when illuminated that the DC bus is at a hazardous voltage. DANGER DC bus capacitors may retain hazardous voltages for up to ten minutes after input power has been removed. Always use a voltmeter to ensure that the DC bus voltage is below 50VDC before servicing the drive. Failure to observe this precaution could result in severe bodily injury or loss of life.

Figure 5-1: Location of LEDs on 230V Single Phase MMC Smart Drive



5.2 Connectors and Switches on the 230V Drive

Figure 5-2: Front Panel, 230V Single Phase (500W, 1kW, 2 kW)

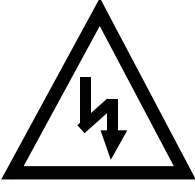
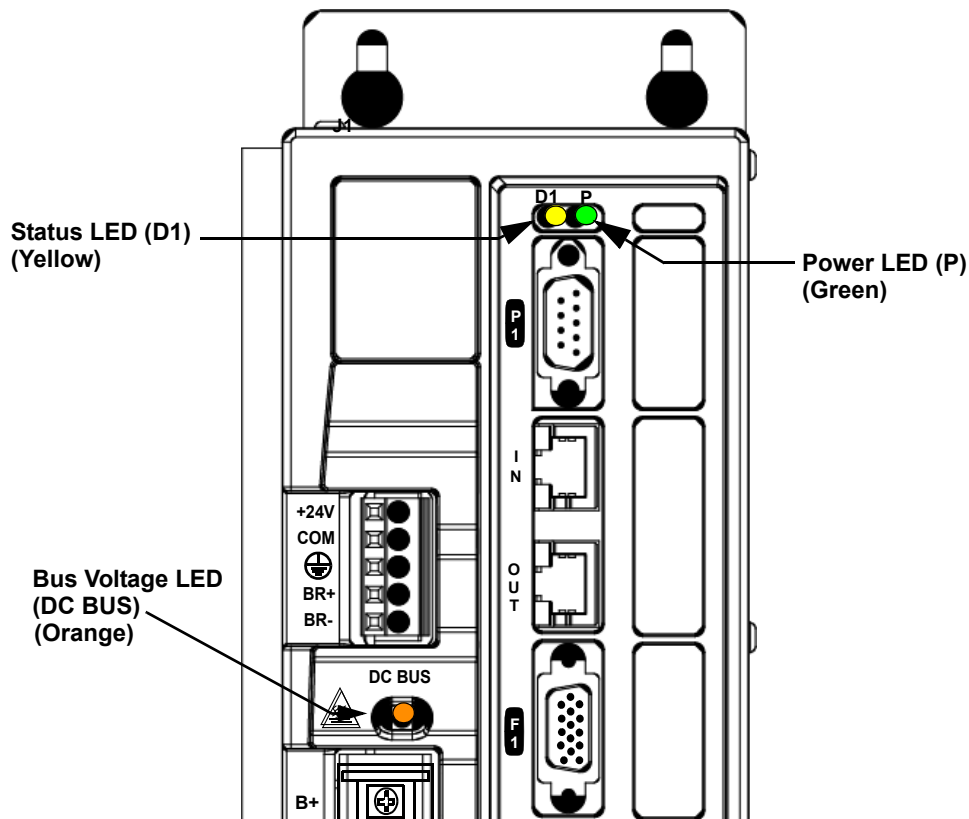
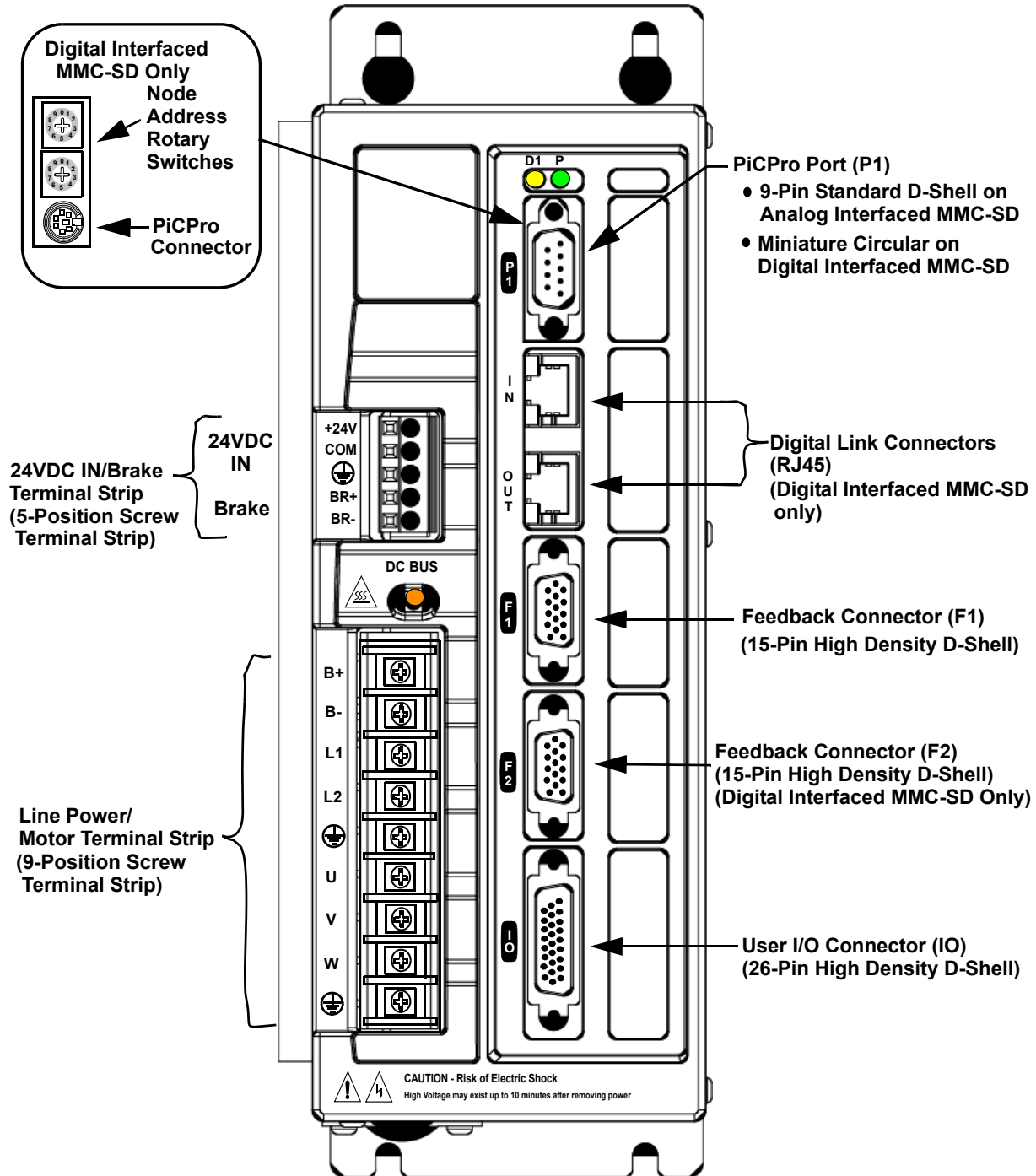

5.2.1 PiCPro Communication Port

5.2.1.1 PiCPro Port (P1)

The PiCPro (P1)port provides RS232 level serial communication for the PiCPro programming interface.

**Table 5-2: Pin Description - PiCPro Port (P1)
(Analog Interfaced MMC-SD)**

PiCPro Port (P1) Signals		
Function	Notes	Pin
Receive Data	Receives parameter and control data from the PiCPro software loaded on a PC.	2
Transmit Data	Transmits data from the user application via the drive to the PiCPro software loaded on a PC.	3
Data Terminal Ready	Indicates that the drive is ready to send data to the PiCPro software loaded on a PC.	4
Signal Ground	Provides the return path for signals	5
Request to send	Sends a request to the PiCPro software loaded on a PC to send data from the drive to PiCPro.	7
Protective Ground	Provides a path for the ground signal to an external single point ground.	Connector Shell

**Table 5-3: Pin Assignment - PiCPro Port (P1)
(Analog Interfaced MMC-SD)**

Pin Assignment PiCPro Port (P1) - 230V Single Phase (500W, 1kW, 2kW)			
Pin	Label	In/Out	Pin Sequence
1	NC	N/A	
2	RS232 Receive Data	In	
3	RS232 Transmit Data	Out	
4	RS232 Data Terminal Ready	Out	
5	RS232 Signal Ground	In/Out	
6	NC	N/A	
7	RS232 Request to Send	Out	
8	NC	N/A	
9	NC	N/A	
Connector Shell	Shield	In	

Table 5-4: Pin Description - PiCPro Port (P1)

(Digital Interfaced MMC-SD)

PiCPro Port (P1) Signals		
Function	Notes	Pin
Receive Data	Receives parameter and control data from the PiCPro software loaded on a PC.	1
Transmit Data	Transmits data from the user application via the drive to the PiCPro software loaded on a PC.	2
Signal Ground	Provides the return path for signals	3 and 5
Protective Ground	Provides a path for the ground signal to an external single point ground.	Connector Shell

**Table 5-5: Pin Assignment - PiCPro Port (P1)
(Digital Interfaced MMC-SD)**

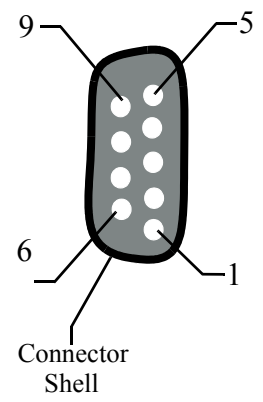
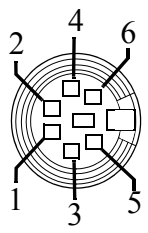
Pin Assignment PiCPro Port (P1) - 230V Single Phase (500W, 1kW, 2kW)			
Pin	Label	In/Out	Pin Sequence
1	RS232 Receive Data	In	Miniature Circular 
2	RS232 Transmit Data	Out	
3	Signal Ground	In/Out	
4	NC	N/A	
5	Signal Ground	In/Out	
6	NC	N/A	
Connector Shield	Shield	In	

5.2.2 Node Address Rotary Switch (Digital Interfaced MMC-SD Only)

Two rotary switches are used to set the drive address. Rotate the switch to the desired address.

Addresses can be set to any number from 1 through 64. The top switch represents values of base ten. The bottom switch represents values of base 1.

As an example, rotating the switch to a setting of 2 on the top switch equals the value of 20 (2 x 10). Rotating the switch on the bottom switch to a setting of 5 equals the value of 5. The actual address setting is 25 (20 + 5).

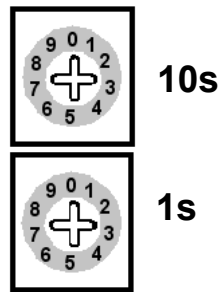

5.2.3 Digital Link Connector (IN/OUT) (Digital Interfaced MMC-SD Only)

The Digital Link connectors allow digital interfaced MMC-SD drives to communicate with one another.

Table 5-6: Pin Description - Digital Link Connector (IN/OUT) (Digital Interfaced MMC-SD Only)

Digital Link Connector (IN/OUT) Signals		Pin	
Function	Notes	In Connector	Out Connector
Receive Data +	Receives data from connected drives.	1	3
Receive Data -	Receives data from connected drives.	2	6
Transmit Data +	Transmits data to connected drives.	3	1
Transmit Data -	Transmits data to connected drives.	6	2
Protective Ground	Provides a path for the ground signal to an external single point ground.	Connector Shell	Connector Shell

**Table 5-7: Pin Assignment - Digital Link Connector (IN/OUT)
(Digital Interfaced MMC-SD Only)**

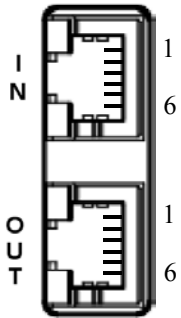
Pin	Label	In/Out	Contact Sequence
IN Connector			RJ-45 Connector 
1	Receive +	In	
2	Receive -	In	
3	Transmit +	Out	
4	Not Used	N/A	
5	Not Used	N/A	
6	Transmit -	Out	
Connector Shield	Provides a path for the ground signal to an external single point ground.	In	
OUT Connector			
1	Transmit +	Out	
2	Transmit -	Out	
3	Receive +	In	
4	Not Used	N/A	
5	Not Used	N/A	
6	Receive -	In	
Connector Shield	Provides a path for the ground signal to an external single point ground.	In	

5.2.4 Feedback Connector (F1)

- All signals (other than the encoder inputs) are bussed internally between the two feedback connectors F1 and F2. The bussed signals include motor commutation inputs, temperature input, and encoder power outputs.
- F1 can interface with incremental encoders, sinewave encoders, and resolvers (using the optional resolver interface module). These signals are conditioned and routed to the I/O connector.

NOTE

Because of the variety of feedback devices that can be used, the following table contains signal descriptions only (no pin numbers). Refer to Table 5-9 for feedback device specific pin numbers.

Table 5-8: Pin Description for Feedback Connector (F1)

F1 Feedback Signals			
Signal Type	Signal Name	Notes	Pin
Incremental Encoder Inputs	A1, A1/, B1, B1/, I1, I1/	Differential A quad B encoder signals.	Pin Assignments vary depending on the type of Feedback Device used. Refer to Table 5-9 for pin assignments.
Sinewave Encoder Inputs	Sin, Sin/, Cos, Cos/	Sinewave Encoder signals	
Sinewave Encoder Data Channel In/Out	RS-485 Data +, RS-485 Data -, RS-485 Clock+, RS-485 Clock-	Rs-485 signals for connecting the Sinewave Encoder Data Channel to the drive	
Motor Commutation Hall Sensor Inputs	Commutation Track S1, S2, S3	Hall device input signals that are used to initialize the commutation angle. They consist of a 74HC14 input with 10 μ s filter and 1 K pull up to +5V. Shared with F2.	
Sinewave Encoder Commutation Inputs	Commutation Sin+, Commutation Sin-	Sinewave signals that are used to initialize the motor commutation angle when a Heidenhein Sincoder is used as the motor feedback device.	
Resolver Inputs	Sin+, Sin-, Cos+, Cos-	Resolver rotor feedback signals used when optional Resolver Interface Board is installed.	
Resolver Outputs	Carrier+, Carrier-	Resolver rotor excitation signals used when optional Resolver Interface Board is installed.	
Temperature Input	Temperature	Thermostat (normally-closed) or Thermistor (Phillips KTY84-130 PTC or equivalent recommended) input for detecting over temperature conditions within the motor.	
Travel Limit Inputs	+ Travel Limit, -Travel Limit	Over travel limit inputs (Reserved for future use).	
Encoder Power Outputs	+5V Source, +9V Source	Regulated +5VDC and regulated +9VDC for powering the attached encoder.	
Sinewave Encoder Reference Mark Input	Ref Mark/	Reference Mark input used with some Sinewave Encoders used to indicate motor position within one revolution.	
Signal and Power Common	Common	Return path for feedback signals and power supplies (+5V and +9V).	

Table 5-9: Encoder/Resolver Pin Assignments for Feedback Connector (F1)

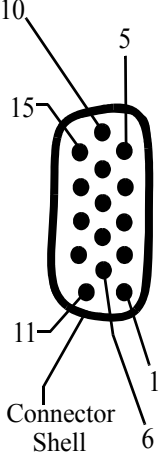
Encoder/Resolver Pin Assignments for Motor Feedback 15 Pin Connector (F1) 230V Single Phase (500W, 1kW, 2kW)								
Pin	Feedback Device						In/ Out	Pin Sequence
	Sinewave Encoder							
	Digital Incremental	Stegmann Hiperface	Endat***	SSI***	Heidenhain Sincoder***	Resolver*		
1	A1	Cos				Cos+	In	15-pin Female HD D-Sub 
2	A1/	Cos/				Cos-		
3	B1	Sine				Sin+		
4	B1/	Sine/				Sin-		
5	I1	RS-485 Data+			Ref Mark	Carrier+	**	
6	Common						In/Out	
7	N/U	+9V Source	N/U	N/U	N/U	N/U	Out	
8	Commutation Track S3	N/U	N/U	N/U	N/U	N/U	In	
9	+ Travel Limit				Commutation Cos+	+Travel Limit		
10	I1/	RS-485 Data-			Ref Mark/	Carrier-	**	
11	Temperature						In	
12	Commutation Track S1	N/U	RS-485 Clock+		Commutation Sin+	N/U	In ****	
13	Commutation Track S2	N/U	RS-485 Clock-		Commutation Sin-	N/U		
14	+5V Source	N/U	+5V Source			N/U	Out	
15	- Travel Limit				Commutation Cos-	-Travel Lim- it	In	
Shell	Shield						N/A	

* Requires installation of optional resolver board.

** The direction of data flow for pins 5 and 10 is as follows:
 Stegmann Hiperface, ENDAT: I/O
 Digital Incremental, SSI, Heidenhain Sincoder: IN
 Resolver: OUT

*** For future use.

**** Pins 12 and 13 are outputs when ENDAT or SSI is installed.

5.2.5 Feedback Connector (F2) (Digital Interfaced MMC-SD Only)

- All motor signals (other than the encoder inputs) are bussed internally between the two feedback connectors F1 and F2. The bussed signals include motor commutation inputs, temperature input, travel limit inputs, and encoder power outputs.
- F2 can be designated (in PiCPro) as the motor feedback connector but only if F1 is not (either one or the other must be designated as such).
- Travel Limits can be defined in PiCPro software as either coming into the MMC Smart Drive at the F2 connector or at the User I/O connector.
- F2 can interface with only incremental type encoders.
- The hall sensor inputs on F1 and F2 are connected together, allowing either F1 or F2 to accept the hall sensor signal, but NOT both. Only one feedback may be connected to motor hall sensor inputs.

Table 5-10: Pin Description for Feedback Connector (F2)

F2 Feedback Signals		
Signal Type	Notes	Pins
Incremental Encoder Input	Differential A quad B encoder signals.	1,2, 3, 4, 5, 10
Motor Commutation Hall Sensor Inputs	Hall-device input signals that are used to initialize the motor commutation angle. They consist of a 74HC14 input with a 10 μ s filter and a 1K pull-up to +5V. Shared with F1.	8, 12, 13
Temperature Input	Thermostat (normally-closed) or Thermistor (Phillips KTY84-130 PTC or equivalent recommended) input for detecting over temperature conditions within the motor.	11
Travel Limit Inputs	Over-travel limit inputs. They consist of a 74HC14 input with a 10 μ s filter and a 1K pull-up to +5V.	9, 15
Encoder Power Outputs	Regulated +5VDC and regulated +9V VDC for powering the attached encoder.	7, 14
Signal and Power Common	Return path for feedback signals and power supplies (+5V and 9 V).	6

**Table 5-11: Pin Assignments for Feedback Connector (F2)
(Digital Interfaced MMC-SD Only)**

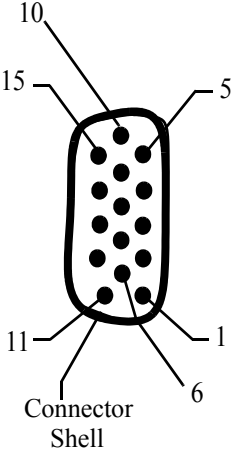
Pin Assignments F2 Feedback 15 Pin Connector 230V Single Phase (500W, 1kW, 2kW)			
Pin	Label	In/Out	Pin Sequence
1	A2	In	15-pin Female HD D-Sub 
2	A2/	In	
3	B2	In	
4	B2/	In	
5	I2	In	
6	Common	In/Out	
7	+9V	Out	
8	S3	In	
9	Travel Limit+	In	
10	I2/	In	
11	Temperature	In	
12	S1	In	
13	S2	In	
14	+5V	Out	
15	Travel Limit-	In	
Shell	Shield	In	

5.2.6 User I/O Connector (IO)

Table 5-12: Pin Description for User I/O Connector (IO)

Signals for User I/O Connector (IO)		
Signal Type	Notes	Pins
Analog Command Inputs (Analog Interfaced MMC-SD only)	<ul style="list-style-type: none"> Analog velocity or torque commands of 0 to +/- 10V Separate scale and offset parameters are used relative to the command signal being velocity or torque 	14, 15
Fast Inputs (Digital Interfaced MMC-SD only)	Used for latching encoder position.	8, 9, 11, 12
General Purpose Software Assignable Inputs	24VDC sourcing type. Default assignments: Pin 17 (GPIN1) = Drive Enable, Pin 18 (GPIN2) = Fault Reset	17, 18, 19, 20, 21, 22
Buffered F1 Encoder Output	<ul style="list-style-type: none"> RS485 drivers are used and the signal that is output depends on the encoder or resolver type used. See Specifications in Chapter 5 of this manual. These signals are generated after the feedback from the F1connector is filtered and processed. 	1, 2, 3, 4, 5, 6
General Purpose Software Assignable Outputs	24VDC sourcing type. Default assignment: Pin 26 (GPOUT4) = Drive Ready	23, 24, 25, 26
IO24V, IO24COM	24 VDC inputs for powering GPIN and GPOUT I/O.	10, 16

Table 5-13: Pin Assignment for User I/O Connector (IO)



Pin Assignment User I/O Connector 26-Pin 230V Single Phase (500W, 1kW, 2kW)								
Pin	Wiring Label	PiCPro I/O Label	In/Out	Pin	Wiring Label	PiCPro I/O Label	In/Out	Pin Sequence
1	FDBK1B A		Out	14	CMD +		In	26-pin Female HD D-Sub 
2	FDBK1B A/		Out	15	CMD -		In	
3	FDBK1B B		Out	16	IO24COM		In	
4	FDBK1B B/		Out	17	GPIN1	Input1	In	
5	FDBK1B I		Out	18	GPIN2	Input2	In	
6	FDBK1B I/		Out	19	GPIN3	Input3	In	
7	Shield		Out	20	GPIN4	Input4	In	
8	GPIN7 +	Input7	In	21	GPIN5	Input5	In	
9	GPIN7 -		In	22	GPIN6	Input6	In	
10	IO24V		In	23	GPOUT1	Output1	Out	
11	GPIN8 +	Input8	In	24	GPOUT2	Output2	Out	
12	GPIN8 -		In	25	GPOUT3	Output3	Out	
13	Shield			26	GPOUT4	Output4	Out	

Figure 5-3: Wiring Diagram for User I/O Connector (IO)

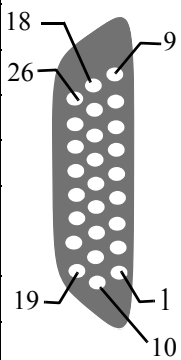
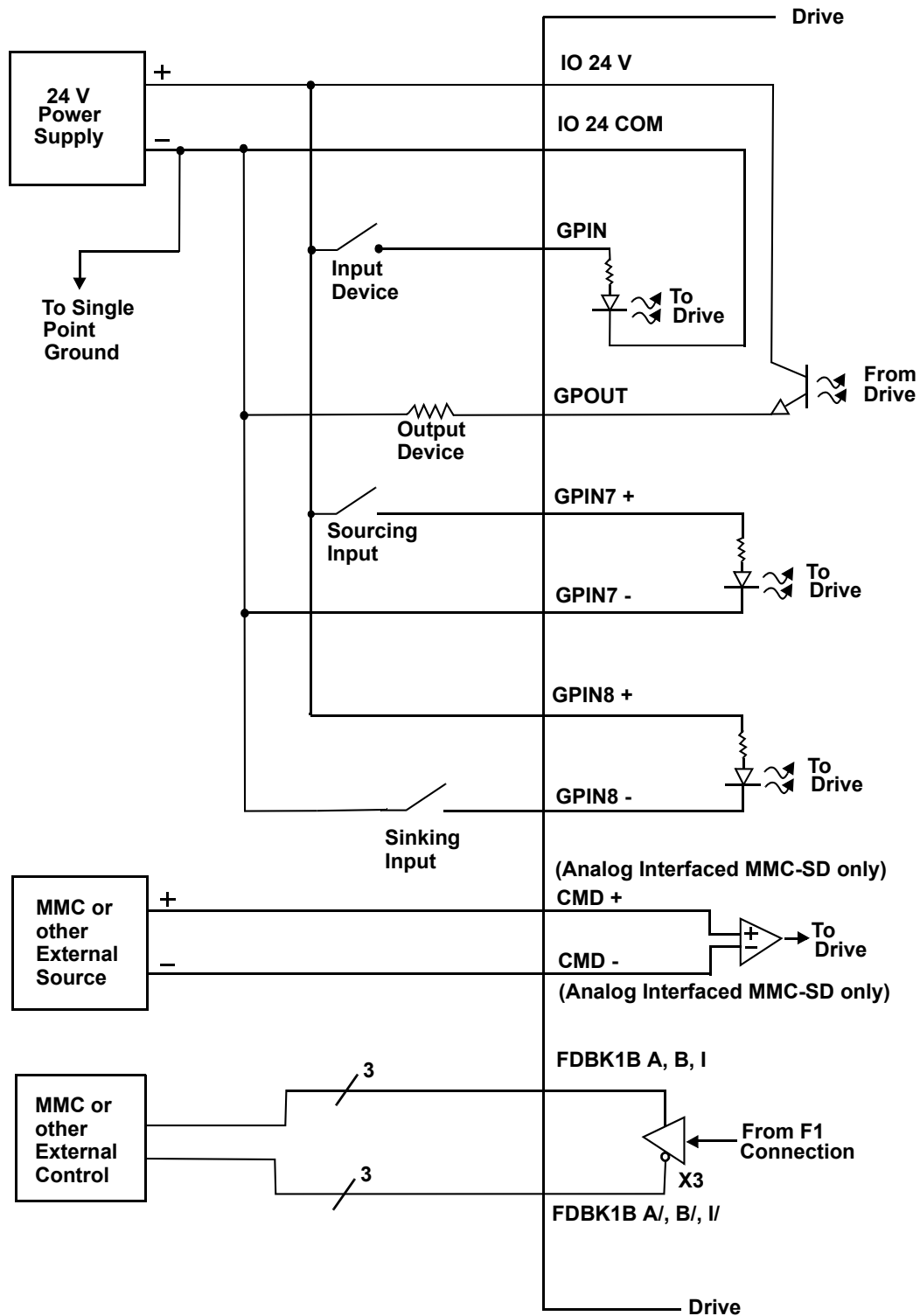

5.2.7 24 VDC IN/Brake Terminal Strip

Table 5-14: Pin Assignment for 24 VDC IN/Brake Terminal Strip

24VDC IN/Brake Terminal Strip					
Terminal	Terminal Label	Signal Type	Signal Description	PiCPro I/O Label	In/Out
+24V COM  BR+ BR-	+24V	Logic Power	+24V user supplied power signal terminal.	N/A	In
	COM	Common	+24V Common	N/A	In
		Protective Ground	Must be connected to Protective Earth Ground (SPG)	N/A	In
	BR+	Brake Relay +	Refer to Figure 5-3 below.	Output5/ Relay	Out
	BR-	Brake Relay -			Out

NOTE

Use of a diode (as shown) or an external RC type snubber is highly recommended for use with inductive loads, especially DC inductive loads.

Figure 5-4: BR+ and BR- Wiring Examples

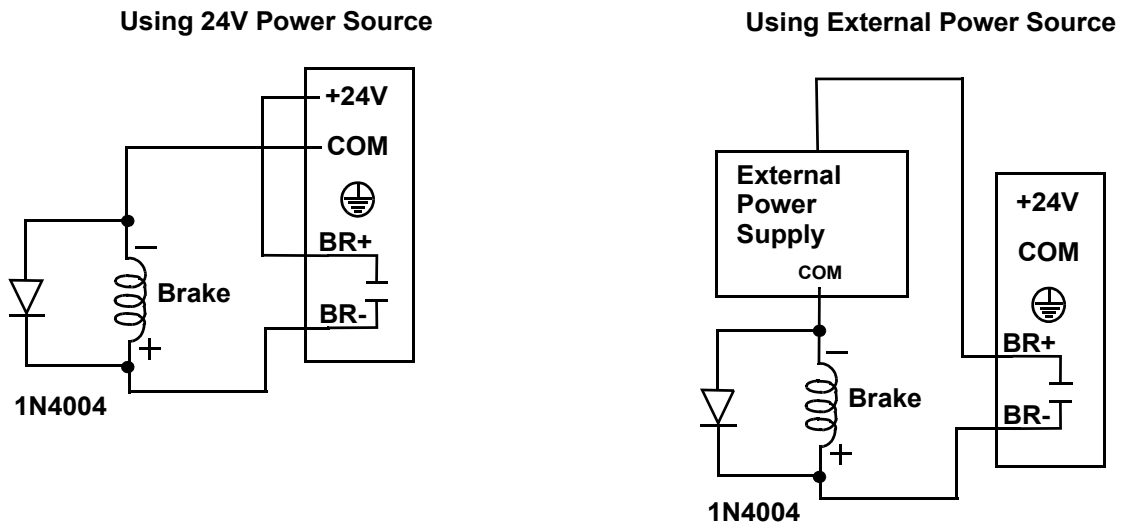

5.2.8 Motor Terminal Strip

Table 5-15: Pin Assignment for Motor Terminal Strip

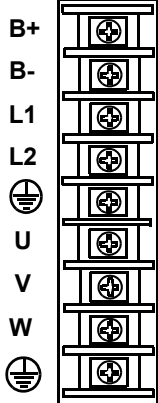
Motor Terminal Strip				
Terminal	Terminal Label	Signal Type	Signal Description	In/Out
 <p>B+ B- L1 L2 ⊕ U V W ⊕</p>	B+	DC Bus	Power from drive to active shunt	Out
	B-			
	L1	AC Power	100-240VAC single phase power in to drive.	In
	L2			
	⊕	Protective Ground	Must be connected to Protective Earth Ground (SPG).	In
	U	Motor Power	Power U-phase from the drive to the motor.	Out
	V		Power V-phase from the drive to the motor.	Out
	W		Power W-Phase from the drive to the motor.	Out
	⊕	Protective Ground	Connection for motor ground.	In

5.3 Specifications - 230V MMC Smart Drive

5.3.1 General Data for all 230V Models

General Drive Data	
Minimum wire size for input power wires	1.5mm ² (16 AWG) 75° C copper.
Maximum tightening torque for power wire terminals	1.17 Nm (10.4 in-lbs.)
Commutation	Three Phase Sinusoidal
Current Regulator	Digital PI 125 µsec. update rate
Velocity Regulator	Digital PID - 250 µsec. update rate
Environmental Data	
Operating Temperature Range	7° C to 55° C (45° F to 131° F)
Storage Temperature Range	-30° C to 70° C (-22° F to 158° F)
Humidity	5% to 95% non-condensing
Altitude	1500 m (5000 ft) Derate 3% for each 300 m above 1500m
Vibration Limits (per IEC 68-2-6) Operating/Non-operating	10-57 Hz (constant amplitude.15 mm) 57 - 2000 Hz (acceleration 2 g)
Shock (per IEC 68-2-27) Non-operating	Four shocks per axis (15g/11 msec)
F1 and F2 Feedback Inputs	
Input receiver type	Maxim 3098 A quad B differential RS422 receiver
Encoder signals	Differential quadrature
Input threshold	±200 mV
Input termination	150Ω, provided internally
Maximum input voltage	5V peak to peak differential -10 to +13.2V common mode
Maximum input signal frequency	720 K Hz (2.88 M feedback counts per second)

General Purpose Inputs	
Configuration	<ul style="list-style-type: none"> • 8 optically isolated 24V DC inputs • Active high • 6 are current sourcing only (current flow into input) • 2 are sink or source
Guaranteed On	15 VDC
Guaranteed Off	5 VDC
Time delay on	1 ms max.
Time delay off	1 ms max.
Input voltage	Nominal 24 VDC, maximum 30 VDC
General Purpose Outputs	
Configuration	<ul style="list-style-type: none"> • 4 optically isolated 24V DC outputs • Active high • Current sourcing only (current into load) • Short circuit and overload protected
Maximum current	50mA per output
Voltage range	24VDC +15%-10%
Time delay on for resistive loads	50 μ sec. max
Time delay off for resistive loads	50 μ sec. max
Leakage current in off state	0.5 mA max
Command Input (Analog Interfaced Digital MMC-SD only)	
Command Input	<ul style="list-style-type: none"> • Analog velocity or torque, 0 to ± 10V • 14 bit effective resolution

Digital Link In/Out Ports (Digital Interfaced MMC-SD only)	
"In" port	Sends and receives high speed data to and from connected MMC-SD's "Out" port.
"Out" port	Sends and receives high speed data to and from connected MMC-SD's "In" port.
User I/O Connector Encoder Emulation Output	
F1 Motor Feedback Type	Input Limit Encoder Emulation Output (A quad B Differential Output)
Incremental Encoder	720 KHz 2.88 M counts/sec. The motor encoder A/B/I inputs are electrically buffered and retransmitted via the User I/O connector.
High Resolution Encoder	100 KHz 400 K counts/sec. The encoder SIN/COS signals are electrically squared and retransmitted as A/B. The index mark "I" is synthesized by the drive control DSP. Absolute position information is not available via the Encoder Emulation Output.
Resolver	500 RPS 2.00 M counts/sec. The field-installable resolver interface module converts the motor resolver to 1024 lines/4096 counts per revolution of A/B encoder output. The module synthesizes the index mark "I" once per revolution of the resolver. Absolute position information is not available via the Encoder Emulation Output.
Conformity	
CE Marked	Conforms to Low Voltage Directive 73/23/EEC (amended by 93/68/EEC) and EMC Directive 89/336/EEC (amended by 92/31/EEC and 93/68/EEC). Conformance is in accordance with the following standards: EN 50178 and EN61800-3 (Pending)
UL and C/UL Listed	E233454 (Pending)

5.3.2 Physical and Electrical Data for 230V Drives

	Model		
	MMC-SD-0.5-230	MMC-SD-1.0-230	MMC-SD-2.0-230
Physical			
Weight	4.9 lbs. (2.23 kg)	5.6 lbs. (2.55 kg)	5.7 lbs. (2.59 kg)
Electrical Specifications			
AC Input Specifications			
Nominal Input Power	1.0 kVA	2.0 kVA	4.0 kVA
Input Voltage	100-240 VAC (nominal), Single Phase, 88-265 VAC (absolute limits)		
Input Frequency	47 - 63 Hz		
Nominal Input Current	5A RMS	9A RMS	18A RMS
Maximum Inrush Current (0-Peak)	70A	70A	70A
Power Loss	22W	37W	70W
AC Output Specifications			
Continuous Output Current (0-Peak)	2.5A	5A	10A
Continuous Output Power			
Input = 115 VAC	250W	500W	1kW
Input = 230 VAC	500W	1kW	2kW
Peak Output Current (0-Peak)	7.5A	15A	30A
Output Frequency	0-266 Hz		
DC Input Power Specifications (24VDC)			
Input Voltage Range	24 VDC +15% -10%		
Typical Input Current	350 mA	650 mA	
Typical Input Wattage	9 W	16 W	
Inrush Current	1.5 A for 10 ms		

Relay Contact for Motor Mechanical Brake		
Rating (resistive load)		
Nominal switching capacity	24 VDC	
Maximum switching power	831 VA	
Maximum switching voltage	250 VAC / 100 VDC	
Maximum switching current	5 A (AC) / 2.5 A (DC)	
Energy Absorbtion Specifications		
DC Bus Capacitance (Internal)	1410 μ F	1880 μ F
Bus overvoltage threshold	420 VDC	
Joules available for energy absorption		
230V motor w/ 115V line input	94 joules	126 joules
230V motor w/ 230V line input	38 joules	51 joules

5.4 Dimensions for 230V MMC Smart Drive

5.4.1 230V 500W Drive - Front View

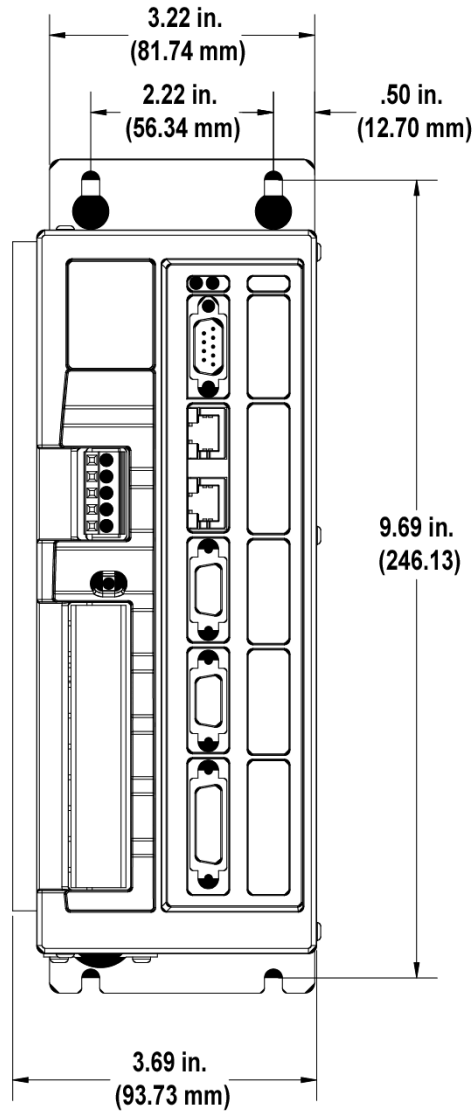

5.4.2 230V 500W Drive - Side View

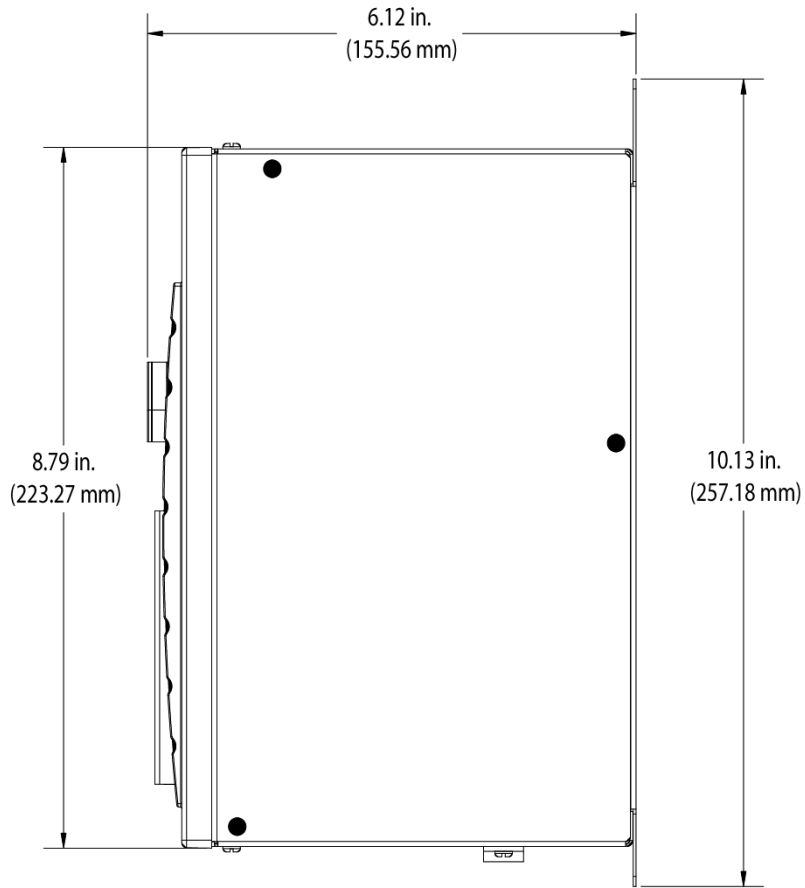

5.4.3 230V 1kW and 2kW Drive - Front View

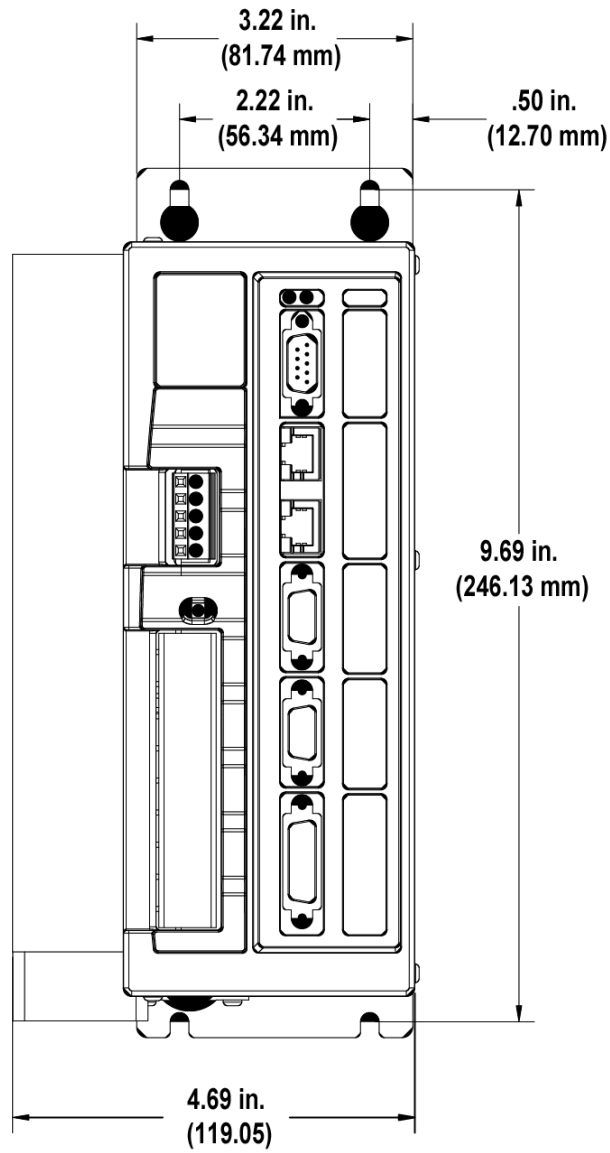

5.4.4 230V 1kW and 2kW Drive - Side View

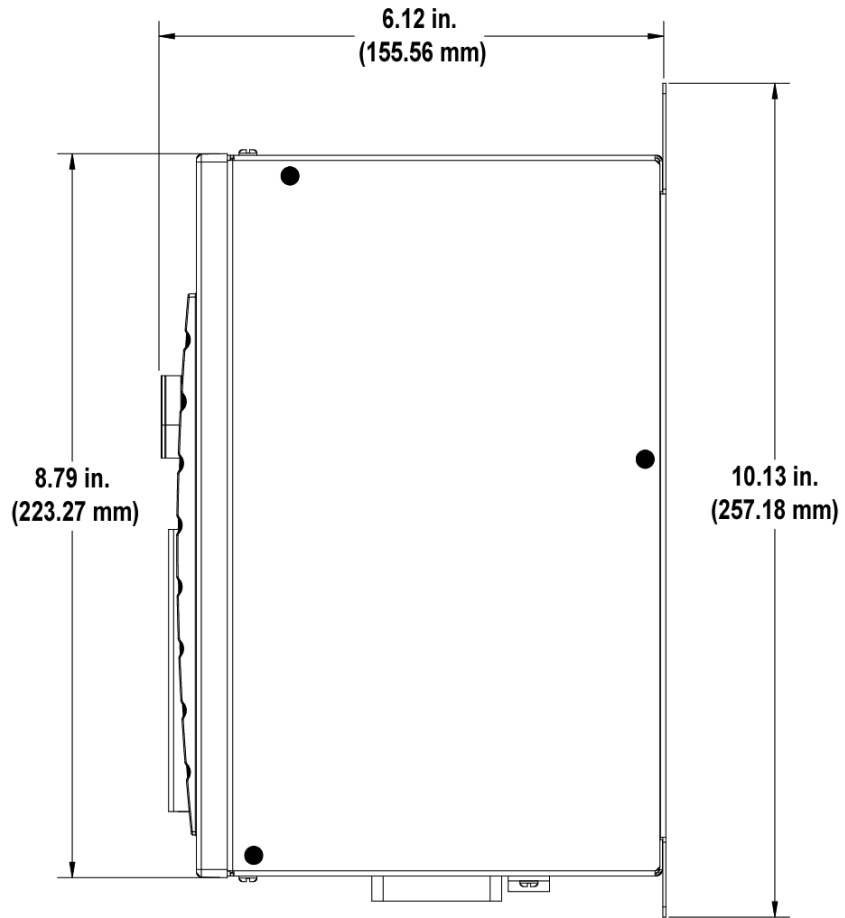

6 460V 3-Phase MMC Smart Drive

6.1 LEDs

Table 6-1: LEDs Description for 460V 3-Phase MMC Smart Drive

LED	Color	Description
P	Green	Power LED. Indicates when illuminated that DC voltage is being supplied to the drive.
D1	Yellow	Status LED. Indicates drive status and fault information.

Figure 6-1: LEDs on the Size 1, Size 2 and Size 3 460V Drives

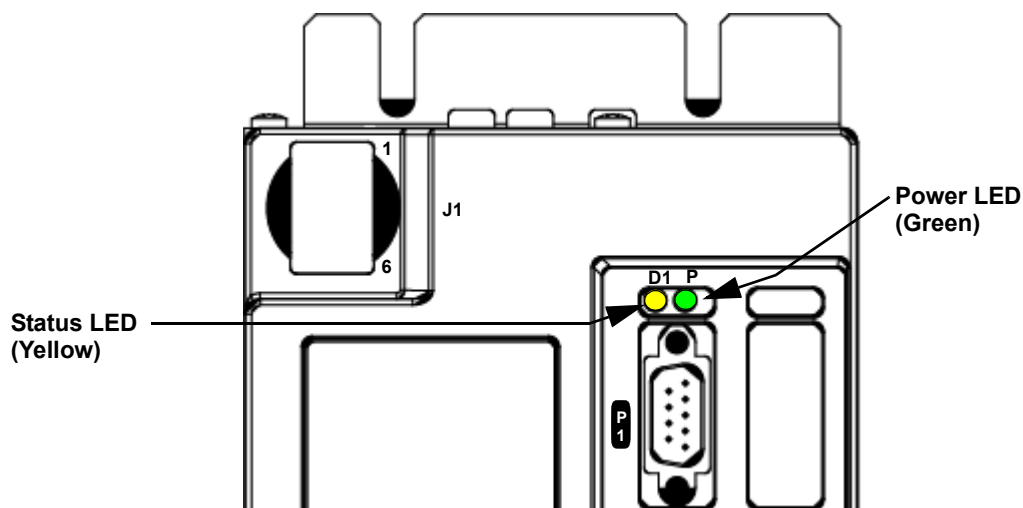

6.2 Connectors on the 460V Drive

6.2.1 Size 1 460V Drive Connectors

Figure 6-2: Connectors on the Size 1 460V Drive

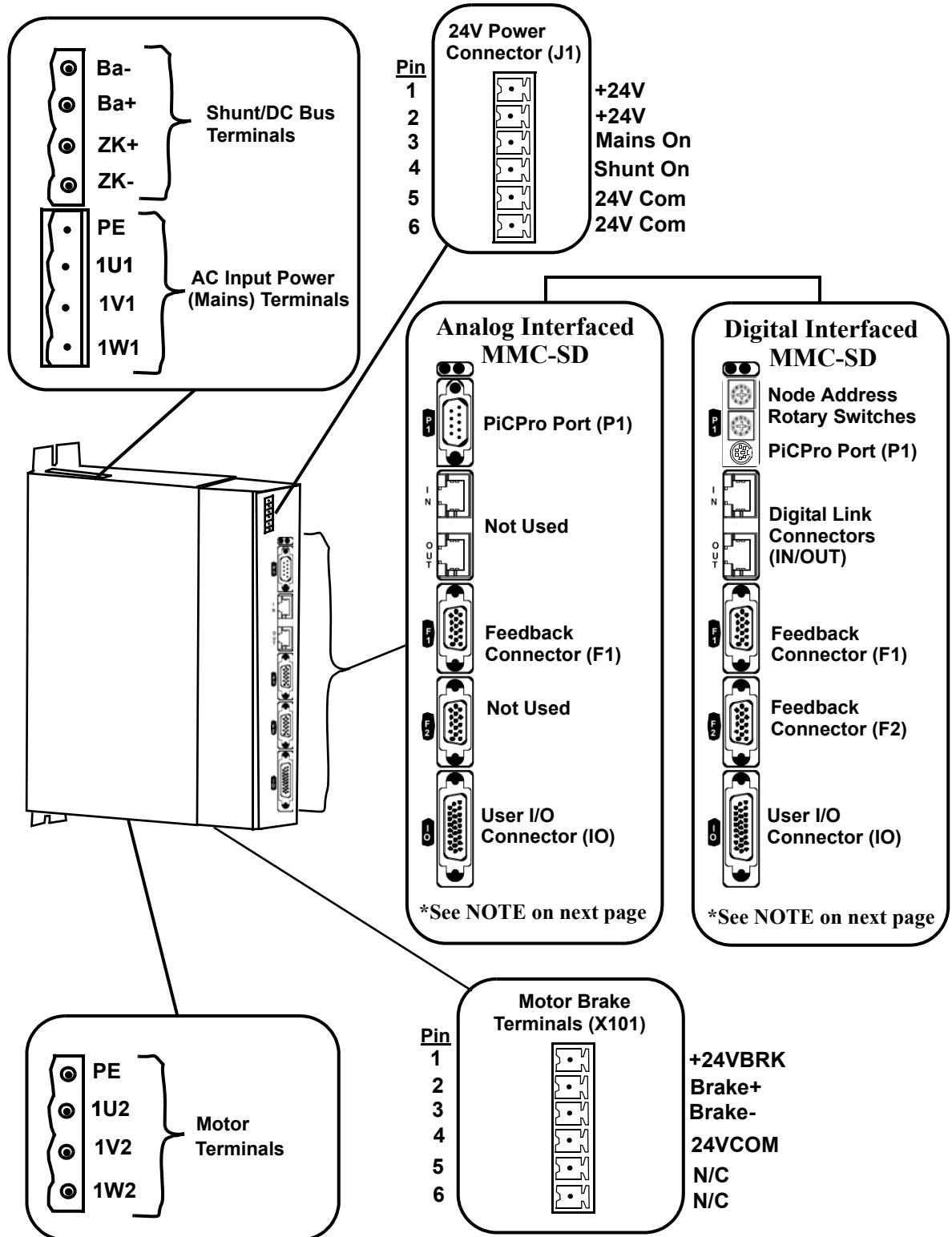

NOTE

The functionality and descriptions for the software control, motor feedback and I/O connectors for the Size 1, Size 2, and Size 3 460V MMC Smart Drives are the same as those used for the 230V MMC Smart Drive. Refer to Chapter 5, *230V Single Phase MMC Smart Drive*, Section 5.2.1, *PiCPro Communication Port*, Section 5.2.4, *Feedback Connector (F1)*, Section 5.2.5, *Feedback Connector (F2) (Digital Interfaced MMC-SD Only)*, and Section 5.2.6, *User I/O Connector (IO)*.

6.2.1.1 Shunt/DC Bus Terminals

Table 6-2: 460V Size 1 Shunt/DC Bus Terminals

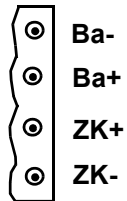
Signal Type	Signal Description	Terminal Label	In/Out	Terminal
Power	External Shunt Resistor. Used to dissipate energy returned to the drive by the motor.	Ba-	Out	
		Ba+		
DC Bus Power	Direct DC bus connection	ZK+	N/A	
		ZK-		

NOTE

The shunt resistor (if installed) across Ba+ and Ba- will be connected across the DC bus when the DC bus reaches the "shunt switch threshold" as shown in the specification table; or when the "Shunt On" input on the J1 connector is active.

NOTE

If a 460V drive is connected to 220V to run a 220V motor, enable the "220V Shunt on 440V Drive" feature using PiCPro, connect GPOUT3 on the USER I/O (IO) connector to the "Shunt On" input on the J1 connector, and install the appropriate shunt resistor across the Ba+ and Ba- terminals. The shunt resistor will be applied across the DC bus when the DC bus voltage rises above 415 volts, and will be removed when the DC bus voltage falls below 400 volts.

6.2.1.2 AC Power Terminal Strip

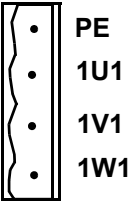
Table 6-3: 460V Size 1 AC Power Terminals				
Signal Type	Signal Description	Terminal Label	In/Out	Terminal
Protective Ground	Protective Earth Ground	PE	Out	
Power	3 phase input power AC source must be center grounded Y system.	1U1	In	
		1V1		
		1W1		

6.2.1.3 Motor Terminals

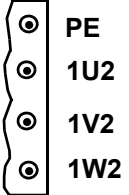
Table 6-4: 460V Size 1 Motor Terminals				
Signal Type	Signal Description	Terminal Label	In/Out	Terminal
Protective Ground	Protective Earth Ground	PE	Out	
Power	Drive output power to motor.	1U2	Out	
		1V2		
		1W2		

6.2.1.4 24V Power Connector (J1)

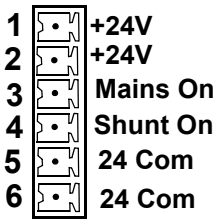
Table 6-5: 460V Size 1 24V Power Connector (J1)					
Signal Type	Signal Description	Pin	Terminal Label	In/Out	Terminal
Power	24 VDC input power	1	+24V	In	Top 
		2	+24V		
24V Logic Output	Reserved for future use, do not use !	3	Mains On	Out	
24V Logic Input	When this input is active, the shunt resistor (if installed) between Ba+ and Ba- is connected across the DC bus.	4	Shunt On	In	
Power	24 VDC input common to the drive.	5	24V Com	In	
		6	24V Com		

6.2.1.5 Motor Brake Terminals (X101)

Table 6-6: 460V Size 1 Motor Brake Terminals (X101)					
Signal Type	Signal Description	Pin	Terminal Label	In/Out	Terminal
Power	24 VDC brake input power	1	+24VBRK	In	Top 
Brake control	Brake connections	2	Brake +	Out	
		3	Brake -	In	
Power	24 VDC common	4	24VCOM	Out	
Not Used.		5	N/C	Not Used	
		6	N/C		

Figure 6-3: Wiring Example for X101 Connector



6.2.2 Size 2 460V Drive

Figure 6-4: Connectors on the Size 2 460V Drive

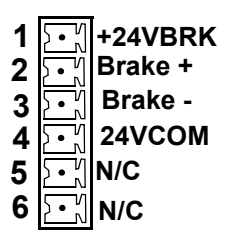
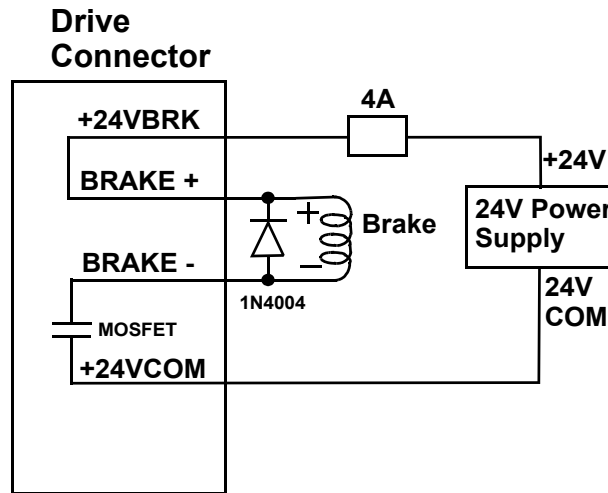
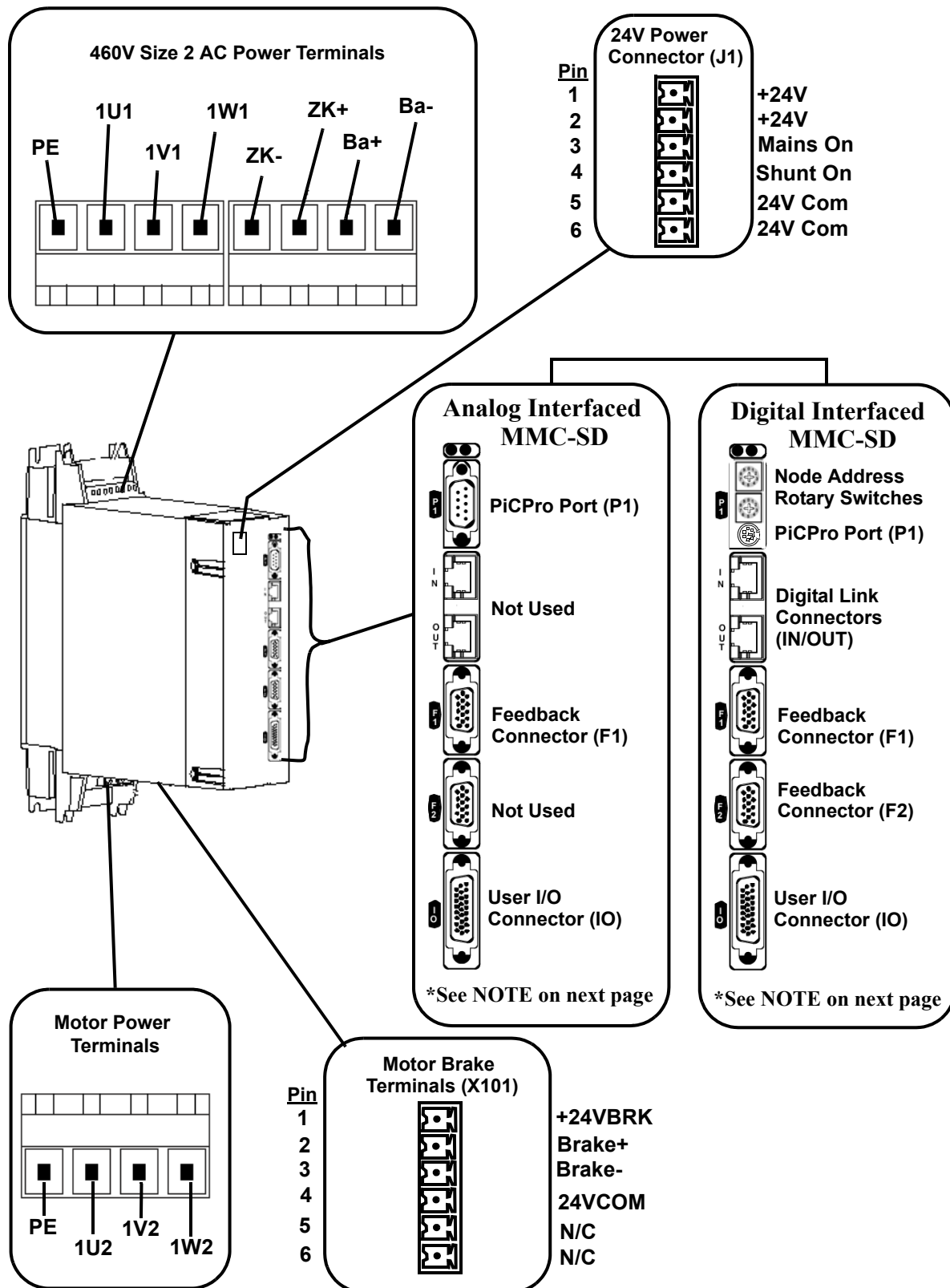

NOTE

The functionality and descriptions for the software control, motor feedback and I/O connectors for the Size 1, Size 2, and Size 3 460V MMC Smart Drives are the same as those used for the 230V MMC Smart Drive. Refer to Chapter 5, *230V Single Phase MMC Smart Drive*, Section 5.2.1, *PiCPro Communication Port*, Section 5.2.4, *Feedback Connector (F1)*, Section 5.2.5, *Feedback Connector (F2) (Digital Interfaced MMC-SD Only)* and Section 5.2.6, *User I/O Connector (IO)*.

6.2.2.1 AC Power Terminals

Table 6-7: 460V Size 2 AC Power Terminals

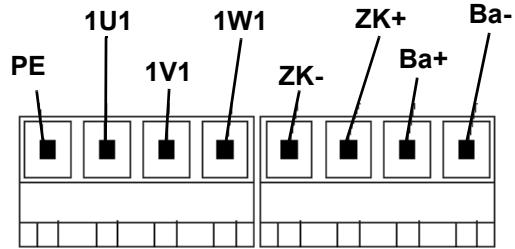

Signal Type	Signal Description	Terminal Label	In/Out
Ground	Protective Ground (Earth)	PE	Out
Power	Three phase AC input power in to drive	1U1	In
		1V1	
		1W1	
DC Bus Power	Direct DC bus connection	ZK-	Out
		ZK+	
Power	External Shunt Resistor used to dissipate energy returned to the drive from motor	Ba+	Out
		Ba-	

NOTE

The shunt resistor (if installed) across Ba+ and Ba- will be connected across the DC bus when the DC bus reaches the "shunt switch threshold" as shown in the specification table; or when the "Shunt On" input on the J1 connector is active.

NOTE

If a 460V drive is connected to 220V to run a 220V motor, enable the "220V Shunt on 440V Drive" feature using PiCPro, connect GPOUT3 on the USER I/O (IO) connector to the "Shunt On" input on the J1 connector, and install the appropriate shunt resistor across the Ba+ and Ba- terminals. The shunt resistor will be applied across the DC bus when the DC bus voltage rises above 415 volts, and will be removed when the DC bus voltage falls below 400 volts.

6.2.2.2 Motor Power Terminals

Table 6-8: 460V Size 2 Motor Power Terminals

Signal Type	Signal Description	Terminal Label	In/Out	Terminal
Ground	Protective Ground (Earth)	PE	Out	
Motor	Power U-phase from the drive to the motor	1U2	Out	
	Power V-phase from the drive to the motor	1V2	Out	
	Power W-phase from the drive to the motor	1W2	Out	

6.2.2.3 24V Power Connector (J1)

Table 6-9: 460V Size 2 24V Power Connector (J1)					
Signal Type	Signal Description	Pin	Terminal Label	In/Out	Terminal
Power	24 VDC input power	1	+24V	In	<p style="text-align: center;">Top</p> <p>1 +24V 2 +24V 3 Mains On 4 Shunt On 5 24 Com 6 24 Com</p>
		2	+24V		
24V Logic Output	Reserved for future use, do not use !	3	Mains On	Out	
24V Logic Input	When this input is active, the shunt resistor (if installed) between Ba+ and Ba- is connected across the DC bus.	4	Shunt On	In	
Power	24 VDC input common to the drive.	5	24V Com	In	
		6	24V Com		

6.2.2.4 Motor Brake Terminals (X101)

Table 6-10: 460V Size 2 Motor Brake Terminals (X101)					
Signal Type	Signal Description	Pin	Terminal Label	In/Out	Terminal
Power	24 VDC brake input power	1	+24VBRK	In	Top 
Brake control	Brake connections	2	Brake +	Out	
		3	Brake -	In	
Power	24 VDC common (supply and magnet)	4	24VCOM	Out	
Not Used.		5	N/C	Not Used	
		6			

Figure 6-5: Wiring Example for X101 Connector



6.2.3 Size 3 460V Drive

Figure 6-6: Connectors on the Size 3 460V Drive

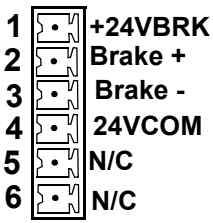
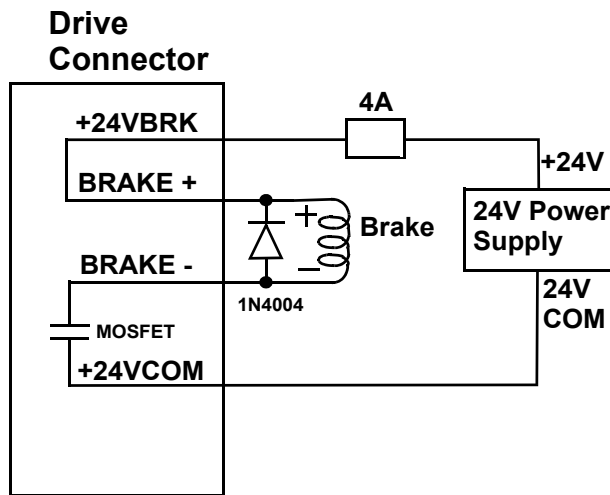
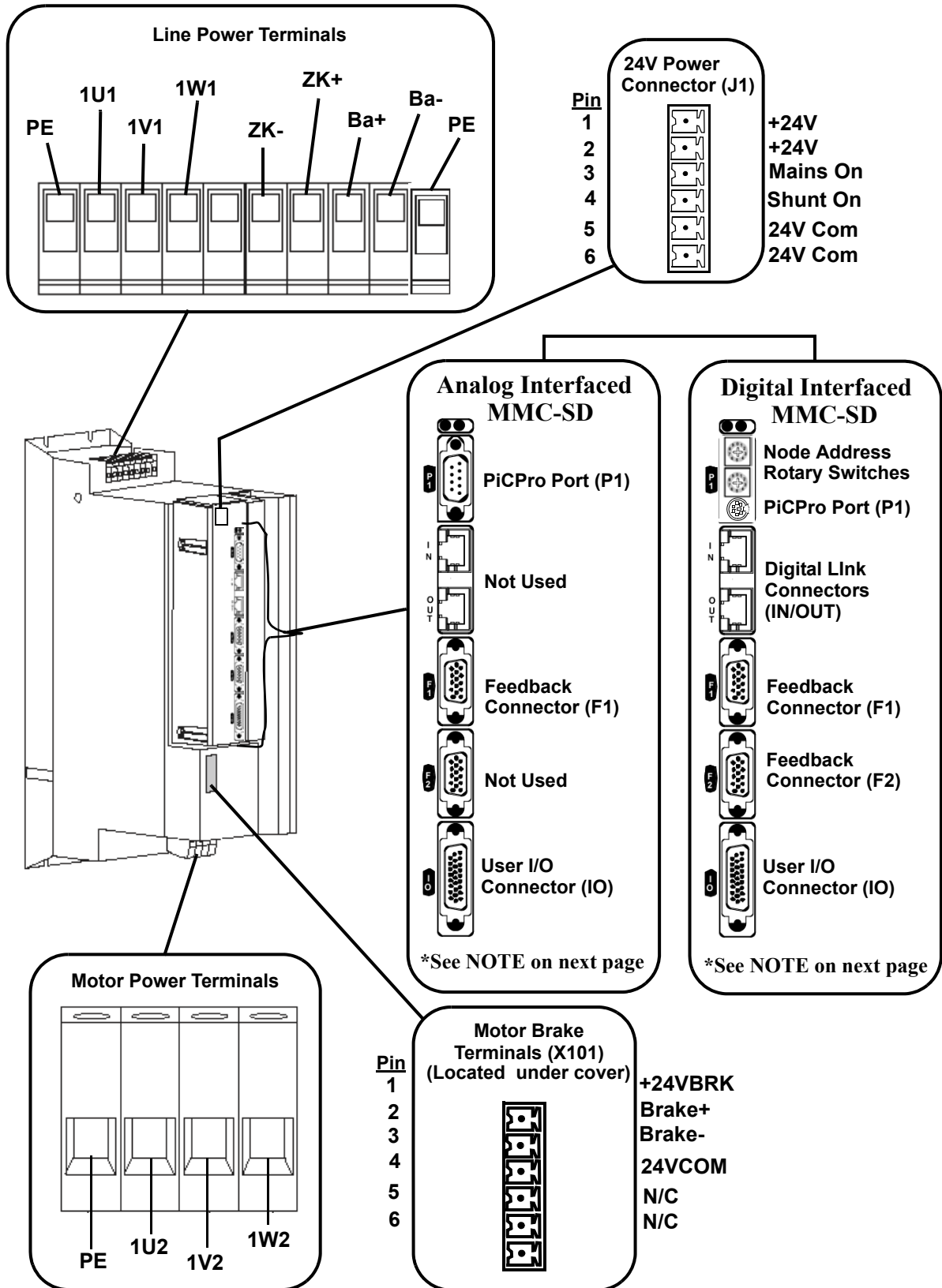

NOTE

The functionality and descriptions for the software control, motor feedback and I/O connectors for the Size 1, Size 2, and Size 3 460V MMC Smart Drives are the same as those used for the 230V MMC Smart Drive. Refer to Chapter 5, *230V Single Phase MMC Smart Drive*, Section 5.2.1, *PiCPro Communication Port*, Section 5.2.4, *Feedback Connector (F1)*, Section 5.2.5, *Feedback Connector (F2) (Digital Interfaced MMC-SD Only)* and Section 5.2.6, *User I/O Connector (IO)*.

6.2.3.1 AC Power Terminals

Table 6-11: 460V Size 3 AC Power Terminals

Signal Type	Signal Description	Terminal Label	In/Out
Ground	Protective Ground (Earth)	PE	Out
Power	Three phase AC input power in to drive	1U1	In
		1V1	
		1W1	
DC Bus Power	Direct DC bus connection	ZK-	Out
		ZK+	
	External Shunt Resistor used to dissipate energy returned to the drive from motor	Ba+	Out
		Ba-	

NOTE

The shunt resistor (if installed) across Ba+ and Ba- will be connected across the DC bus when the DC bus reaches the "shunt switch threshold" as shown in the specification table; or when the "Shunt On" input on the J1 connector is active.

NOTE

If a 460V drive is connected to 220V to run a 220V motor, enable the "220V Shunt on 440V Drive" feature using PiCPro, connect GPOUT3 on the USER I/O (IO) connector to the "Shunt On" input on the J1 connector, and install the appropriate shunt resistor across the Ba+ and Ba- terminals. The shunt resistor will be applied across the DC bus when the DC bus voltage rises above 415 volts, and will be removed when the DC bus voltage falls below 400 volts.

6.2.3.2 Motor Power Terminals

Table 6-12: 460V Size 3 Motor Power Terminals

Signal Type	Signal Description	Terminal Label	In/Out	Terminal
Ground	Protective Ground (Earth)	PE	Out	
Motor	Power U-phase from the drive to the motor	1U2	Out	
	Power V-phase from the drive to the motor	1V2	Out	
	Power W-phase from the drive to the motor	1W2	Out	

6.2.3.3 24V Power Connector (J1)

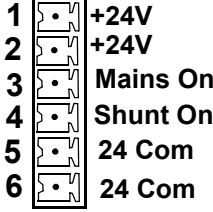
Table 6-13: 460V Size 3 24V Power Connector (J1)					
Signal Type	Signal Description	Pin	Terminal Label	In/Out	Terminal
Power	24 VDC input power	1	+24V	In	Top 
		2	+24V		
24V Logic Output	Reserved for future use, do not use !	3	Mains On	Out	
24V Logic Input	When this input is active, the shunt resistor (if installed) between Ba+ and Ba- is connected across the DC bus.	4	Shunt On	In	
Power	24 VDC input common to the drive.	5	24V Com	In	
		6	24V Com		

6.2.3.4 Motor Brake Terminals (X101)

Table 6-14: 460V Size 3 Motor Brake Terminals (X101)					
Signal Type	Signal Description	Pin	Terminal Label	In/Out	Terminal
Power	24 VDC brake input power	1	+24VBRK	In	Top 
Brake control	Brake connections	2	Brake +	Out	
		3	Brake -	In	
Power	24 VDC common (supply and magnet)	4	24VCOM	Out	
Not Used.		5	N/C	Not Used	
		6			

Figure 6-7: Wiring Example for X101 Connector



6.3 Typical 460V Drive Connection Layout

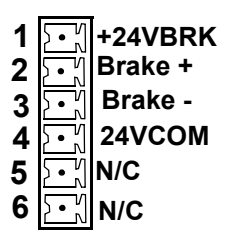
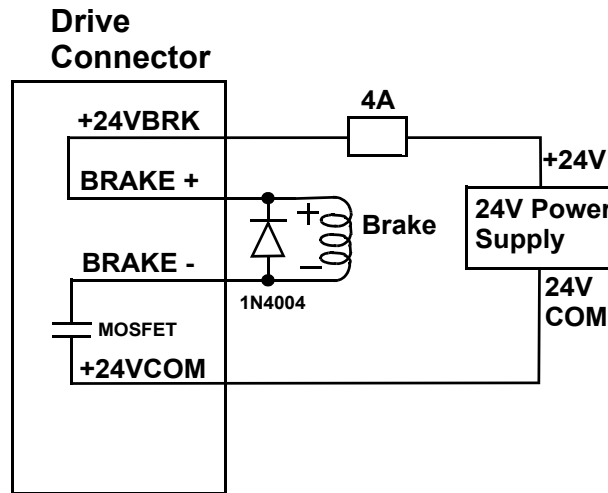
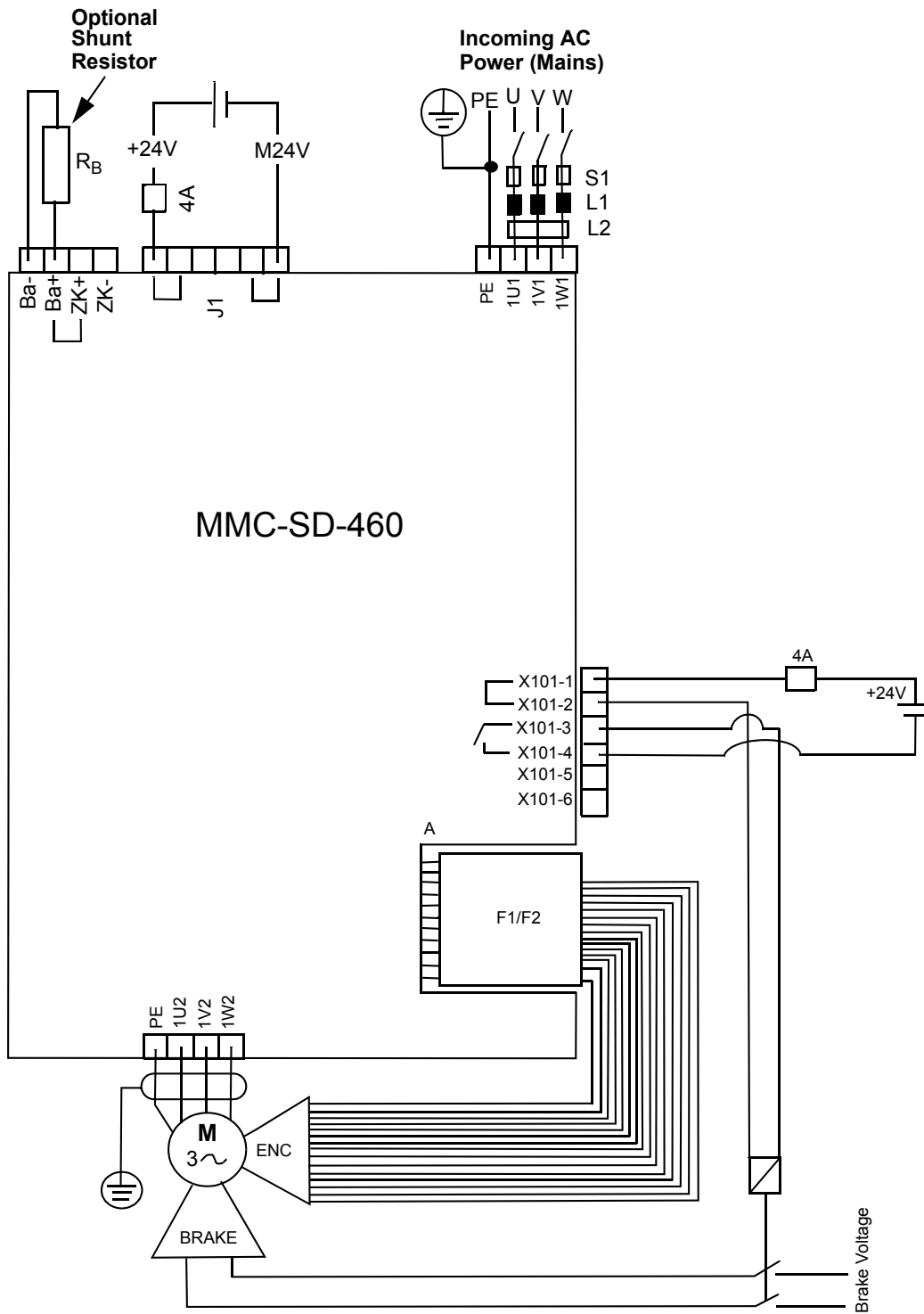

6.4 Specifications - 460V MMC Smart Drive

6.4.1 Common Data for Size 1/Size 2/Size 3 (All Models)

General Drive Data	
Minimum wire size for input power wires	1.5mm ² (16 AWG) 75° C copper
Maximum tightening torque for power wire terminals	1.25Nm (11 in-lbs.)
Commutation	3 Phase Sinusoidal, Space Vector Modulated (SVM)
Current Regulator	Digital PI 125 µsec update rate
Velocity Regulator	Digital PID - 250 µsec update rate
General Operating Data	
Operating Temperature Range	7° C to 50° C (45° F to 122° F)
Storage Temperature Range	-30° C to 70° C (-22° F to 158° F)
Humidity	5% to 95% non-condensing
Altitude	1500m (5000ft) Derate 3% for each 300 m above 1500m
Vibration Limits (per IEC 68-2-6) Operating/Non-operating	10-57Hz (constant amplitude .15mm) 57 - 2000Hz (acceleration 2g)
Shock (per IEC 68-2-27) Non-operating	15g/11msec per axis
F1 and F2 Feedback Inputs	
Input receiver type	Maxim 3098 A quad B differential RS422 receiver
Encoder signals	Differential quadrature
Input threshold	±200mV
Input termination	150Ω, provided internal
Maximum input voltage	5V _{pp} differential -10 to +13.2V common mode
Maximum input signal frequency	720KHz (2.88 M feedback unit count rate)

General Purpose Inputs	
Configuration	<ul style="list-style-type: none"> • 8 optically isolated 24V DC inputs • Active high • 6 are current sourcing only (current flow into input) • 2 are sink or source
Guaranteed On	15VDC
Guaranteed Off	5VDC
Time delay on	1ms max.
Time delay off	1ms max.
Input voltage	Nominal 24VDC, maximum 30VDC
General Purpose Outputs	
Configuration	<ul style="list-style-type: none"> • 4 optically isolated 24VDC outputs • Active high • Current sourcing only (current into load) • Short circuit and overload protected
Maximum current	50mA per output
Voltage range	24VDC +15%-10%
Time delay on for resistive loads	50µsec. max
Time delay off for resistive loads	50µsec. max
Leakage current in off state	0.5mA max
Command Input/Output	
Command Input	<ul style="list-style-type: none"> • Analog velocity or torque, 0 to $\pm 10V$ • 14 bit effective resolution
Digital Link In/Out Ports (Digital Interfaced MMC-SD only)	
"In" port	Sends and receives high speed data to and from connected MMC-SD's "Out" port.
"Out" port	Sends and receives high speed data to and from connected MMC-SD's "In" port.

User I/O Connector Encoder Emulation Output		
F1 Motor Feedback Type	Input Limit	Encoder Emulation Output (A quad B Differential Output)
Incremental Encoder	720KHz 2.88 M counts/sec.	The motor encoder A/B/I inputs are electrically buffered and retransmitted via the User I/O connector.
High Resolution Encoder	100KHz 400K counts/sec.	The encoder SIN/COS signals are electrically squared and retransmitted as A/B. The index mark "I" is synthesized by the drive control DSP. Absolute position information is not available via the Encoder Emulation Output.
Resolver	500RPS 2.00M counts/sec.	The field-installable resolver interface module converts the motor resolver to 1024 lines/4096 counts per revolution of A/B encoder output. The module synthesizes the index mark "I" once per revolution of the resolver. Absolute position information is not available via the Encoder Emulation Output.
Conformity		
CE Marked	Conforms to Low Voltage Directive 73/23/EEC (amended by 93/68/EEC) and EMC Directive 89/336/EEC (amended by 92/31/EEC and 93/68/EEC). Conformance is in accordance with the following standards: EN 50178 and EN61800-3 (Pending)	
UL and C/UL Listed	E233454 (Pending)	

6.4.2 Physical/Electrical Data for 460V Size 1 Drives

	Model	
	MMC-SD-1.3-460	MMC-SD-2.4-460
Physical		
Weight	10 lbs.	
Electrical Specifications		
AC Input Specifications		
Nominal Input Power	1.94kVA	3.33kVA
Input Voltage	200-460 VAC (nominal), Three Phase, 180-528 VAC (absolute limits)	
Input Frequency	47-63Hz	
Nominal Input Current	2.44A RMS	4.18A RMS
Maximum Inrush Current	4.56A RMS	7.81A RMS
Power Loss	34W	60W
AC Output Specifications		
Continuous Output Current (0-peak)	3.0A	5.5A
Continuous Output Power		
Input = 230 VAC	.65kW	1.2kW
Input = 460 VAC	1.3kW	2.4kW
Peak Output Current (0-Peak)	6.0A	11.0A
Output Frequency	0-300Hz	
DC Input Power Specifications (24VDC)		
Input Voltage Range	24VDC +15% -10%	
Typical Input Current	700mA	
Typical Input Wattage	17W	
Inrush Current	4A for 10ms	

NOTE: AC Current is specified for nominal input voltage of 460 VAC. Current for input voltages between 400 and 480 VAC equals approximately:
 (current for 460 VAC) x 460/input voltage

Internal Holding Brake Driver		
Maximum Current	0.5A	
Energy Absorption Specifications		
DC Bus Capacitance (Internal)	110 μ F	240 μ F
Shunt Switch Threshold	780VDC	
Joules available for energy absorption		
230V motor w/ 230V line input	3 joules	7 joules
460V motor w/ 230V line input	28 joules	60 joules
460V motor w/ 460V line input	10 joules	22 joules
External Shunt		
Maximum shunt resistor current	5.9A (AC)	
Minimum shunt resistor	130 Ω	
Maximum shunt resistor power at minimum shunt resistor	4.5kW	5kW

6.4.3 Physical/Electrical Data for 460V Size 2 Drive

	Model		
	MMC-SD-4.0-460	MMC-SD-6.0-460	MMC-SD-8.0-460
Physical			
Weight	16 lbs.		
Electrical Specifications			
AC Input Specifications			
Nominal Input Power	5.6kVA	8.6kVA	11.8kVA
Input Voltage	200-460 VAC (nominal), Three Phase, 180-528 VAC (absolute limits)		
Input Frequency	47-63Hz		
Nominal Input Current	7A RMS	10.8A RMS	14.8A RMS
Maximum Inrush Current	13.2A RMS	20.2A RMS	27.7A RMS
Power Loss	102W	150W	204W
AC Output Specifications			
Continuous Output Current (0-Peak)	9.0A	13.5A	18.0A
Continuous Output Power			
Input = 230 VAC	2.0kW	3.0kW	4.0kW
Input = 460 VAC	4.0kW	6.0kW	8.0kW
Peak Output Current (0-peak)	18.0A	27.0A	36.0A
Output Frequency	0Hz to 300Hz		
Internal Holding Brake Driver			
Maximum Current	0.5A		

NOTE: AC Current is specified for nominal input voltage of 460VAC. Current for input voltages between 400 and 480VAC equals approximately:
 $(\text{current for 460VAC}) \times 460/\text{input voltage}$

460V 3-Phase MMC Smart Drive

DC Input Power Specifications (24VDC)			
Input Voltage Range	24VDC +15% -10%		
Typical Input Current	1050mA		
Typical Input Wattage	25W		
Inrush Current	4A for 10ms		
Energy Absorbtion Specifications			
DC Bus Capacitance (Internal)	470 μ F	705 μ F	
Shunt Switch Threshold	780VDC		
Joules available for energy absorption			
230V motor w/ 230V line input	13 joules	19 joules	
460V motor w/ 230V line input	188 joules	177 joules	
460V motor w/ 460V line input	44 joules	66 joules	
External Shunt			
Maximum shunt resistor current	9A (AC)	9A (AC)	9A (AC)
Minimum shunt resistor	86 Ω	60 Ω	44 Ω
Maximum shunt resistor power at minimum shunt resistor	7kW	10kW	14kW

6.4.4 Physical/Electrical Data for 460V Size 3 Drive

	Model		
	MMC-SD-12.0-460	MMC-SD-16.0-460	MMC-SD-24.0-460
Physical			
Weight	35 lbs.		
Electrical Specifications			
AC Input Specifications			
Nominal Input Power	13.3kVA	16.8kVA	26.3 kVA
Input Voltage	200-460VAC (nominal), Three Phase, 180-528VAC (absolute limits)		
Input Frequency	47-63Hz		
Nominal Input Current	16.7A RMS	21.1A RMS	33.1A RMS
Maximum Inrush Current	32.2A RMS	39.2A RMS	61.8A RMS
Power Loss	300W	390W	600W
AC Output Specifications			
Continuous Output Current (0-Peak)	27.5A	36.5A	55.0A
Continuous Output Power			
Input = 230 VAC	6.0kW	8.0kW	12.0kW
Input = 460 VAC	12.0kW	16.0kW	24.0kW
Peak Output Current (0-peak)	55.0A	73.0A	110.0A
Output Frequency	0Hz to 300Hz		
Internal Holding Brake Driver			
Maximum Current	0.5A		

NOTE: AC Current is specified for nominal input voltage of 460 VAC. Current for input voltages between 400 and 480 VAC equals approximately:
 $(\text{current for 460 VAC}) \times 460/\text{input voltage}$

460V 3-Phase MMC Smart Drive

DC Input Power Specifications (24VDC)			
Input Voltage Range	24VDC +15% -10%		
Typical Input Current	1050mA		
Typical Input Wattage	25W		
Inrush Current	4A for 10ms		
Energy Absorbtion Specifications			
DC Bus Capacitance (Internal)	820 μ F	1230 μ F	1640 μ F
Shunt Switch Threshold	780VDC		
Joules available for energy absorption			
230V motor w/ 230V line input	22 joules	33 joules	45 joules
460V motor w/ 230V line input	206 joules	309 joules	412 joules
460V motor w/ 460V line input	76 joules	114 joules	152 joules
External Shunt			
Maximum shunt resistor current	36A (AC)		50A (AC)
Minimum shunt resistor	22 Ω		16 Ω
Maximum shunt resistor power at minimum shunt resistor	29kW		40kW

6.5 Dimensions for the 460V Drives

6.5.1 Size 1 460V Drive - Front View

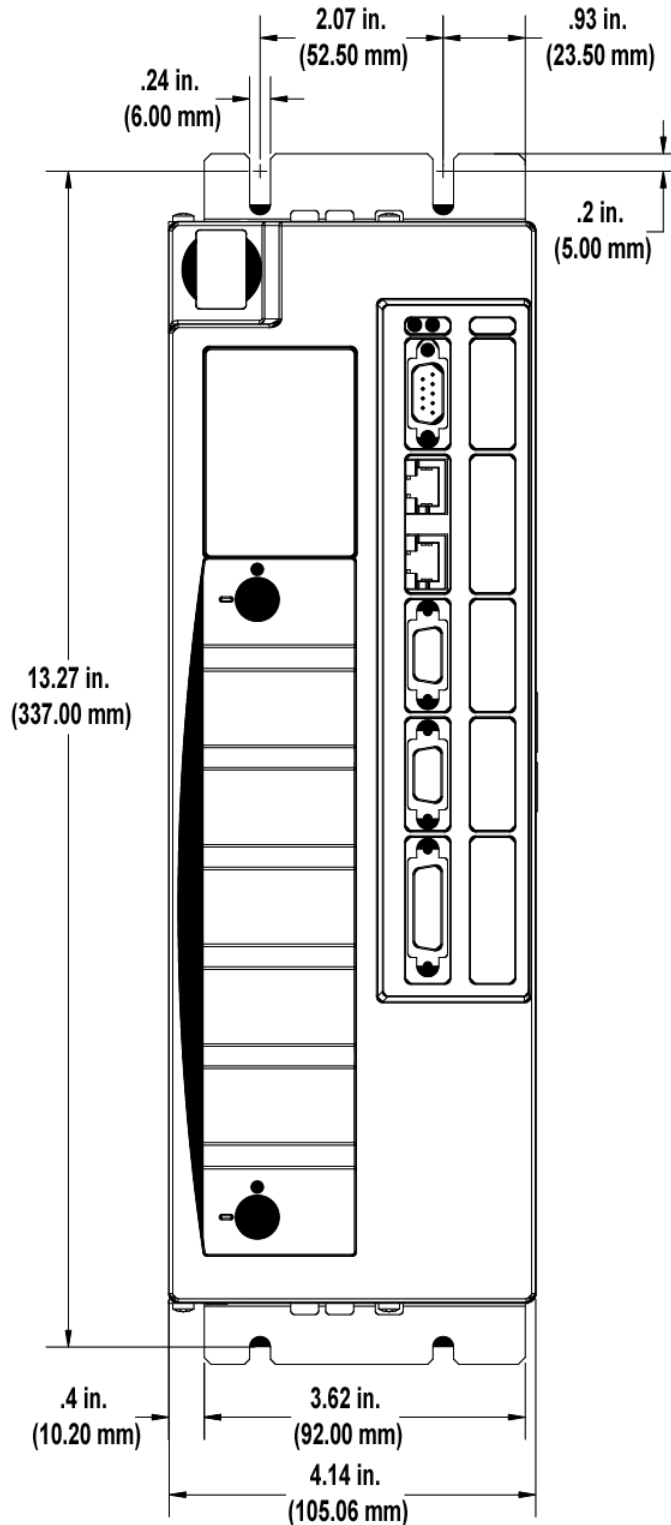

6.5.2 Size 1 460V Drive - Side View

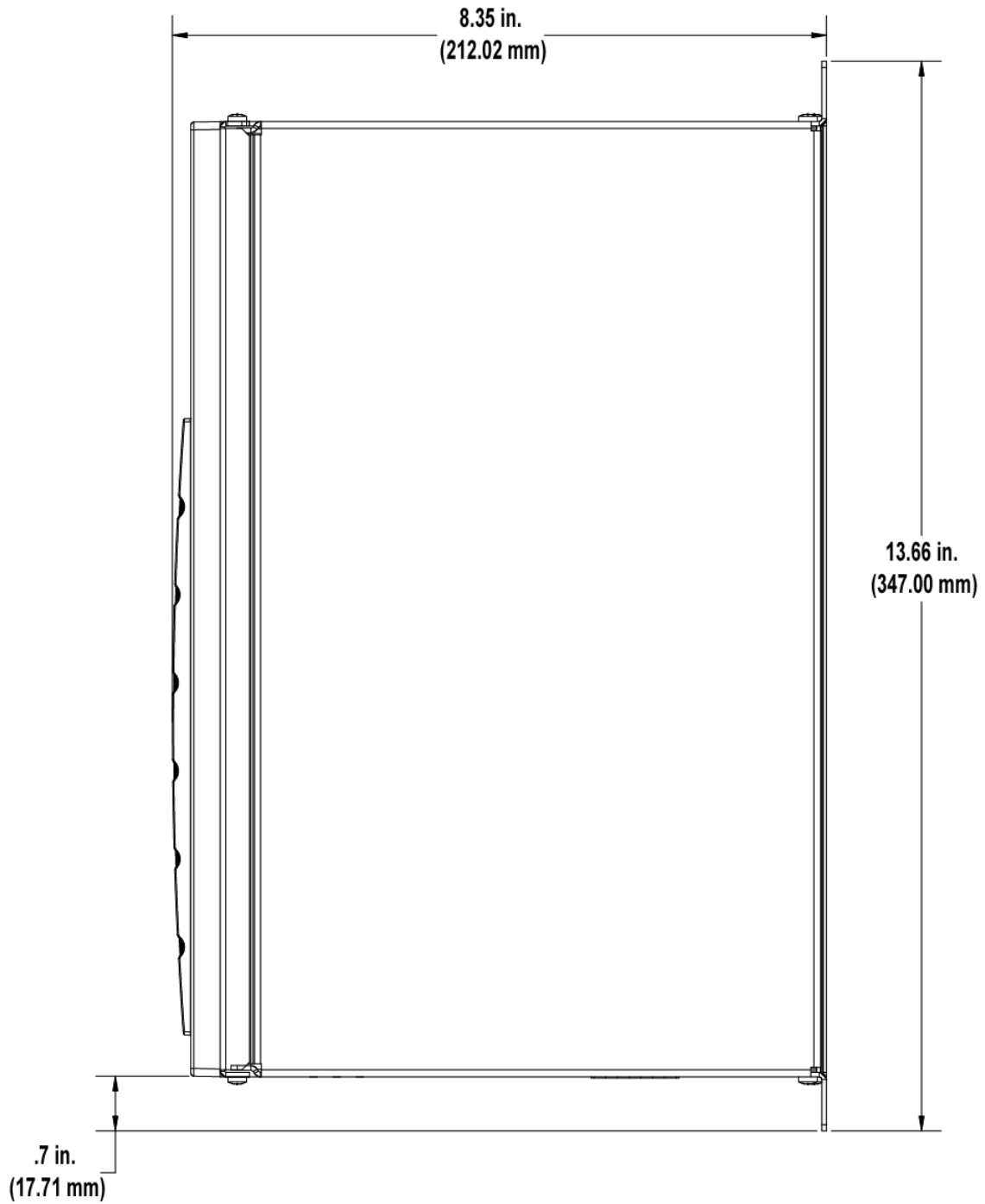

6.5.3 Size 2 460V Drive - Front View

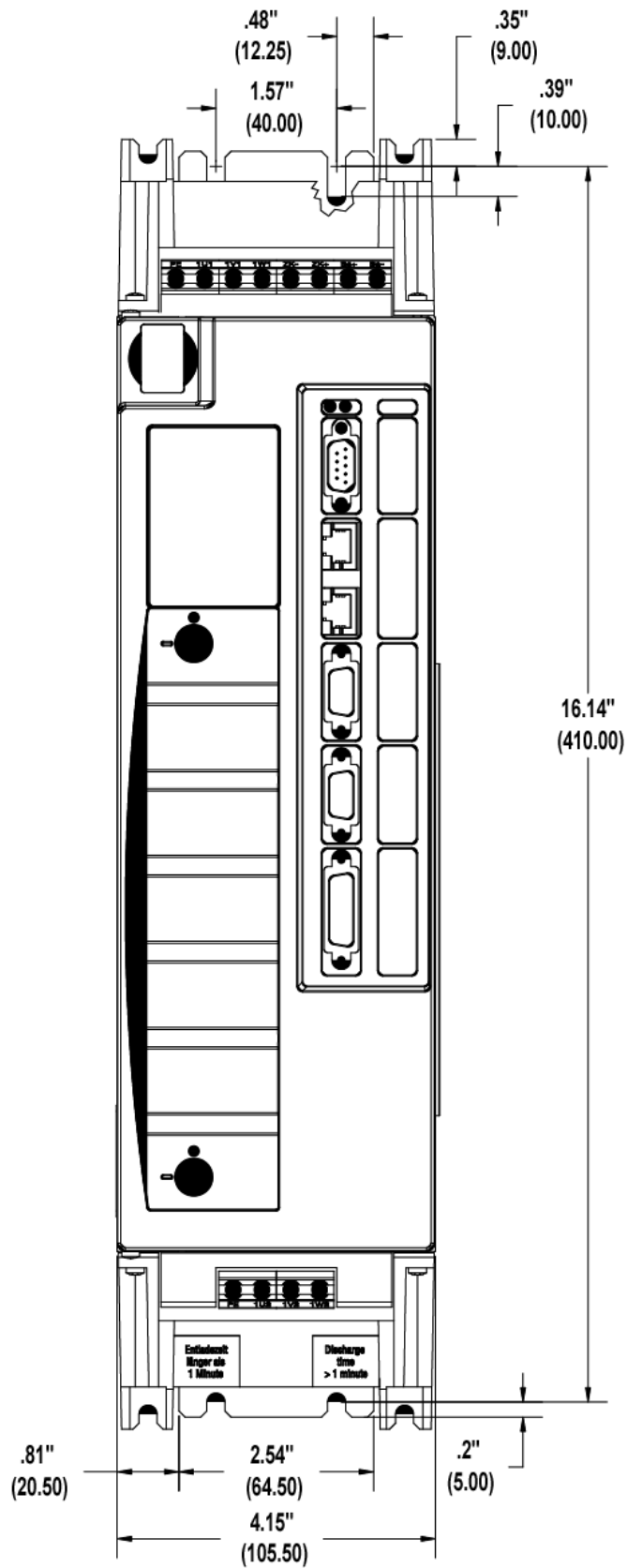

6.5.4 Size 2 460V Drive - Side View

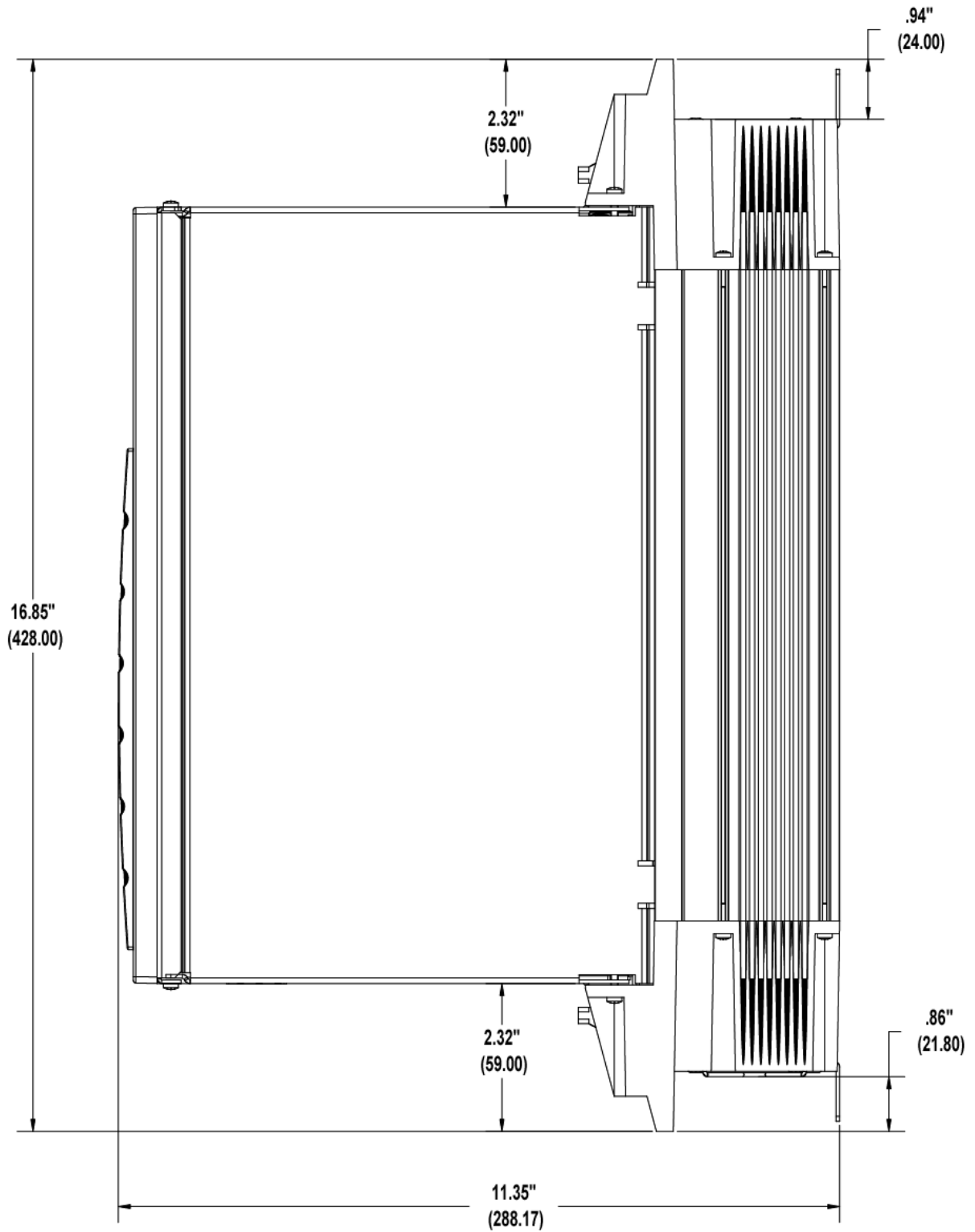

6.5.5 Size 3 460V Drive - Front View

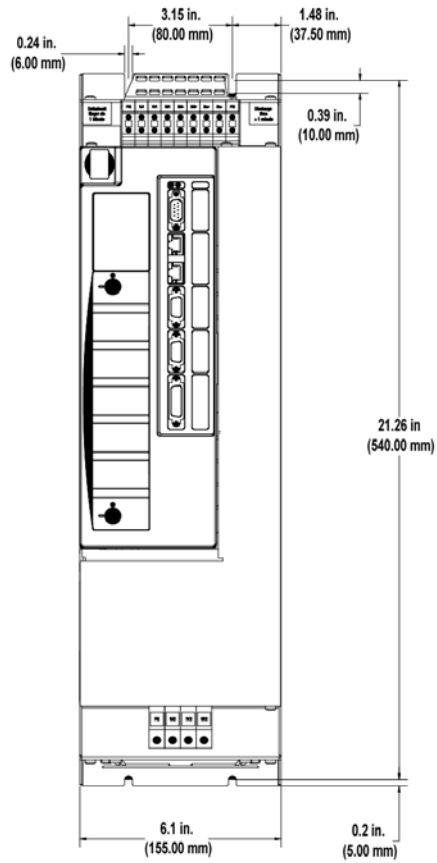

6.5.6 Size 3 460V Drive - Side View

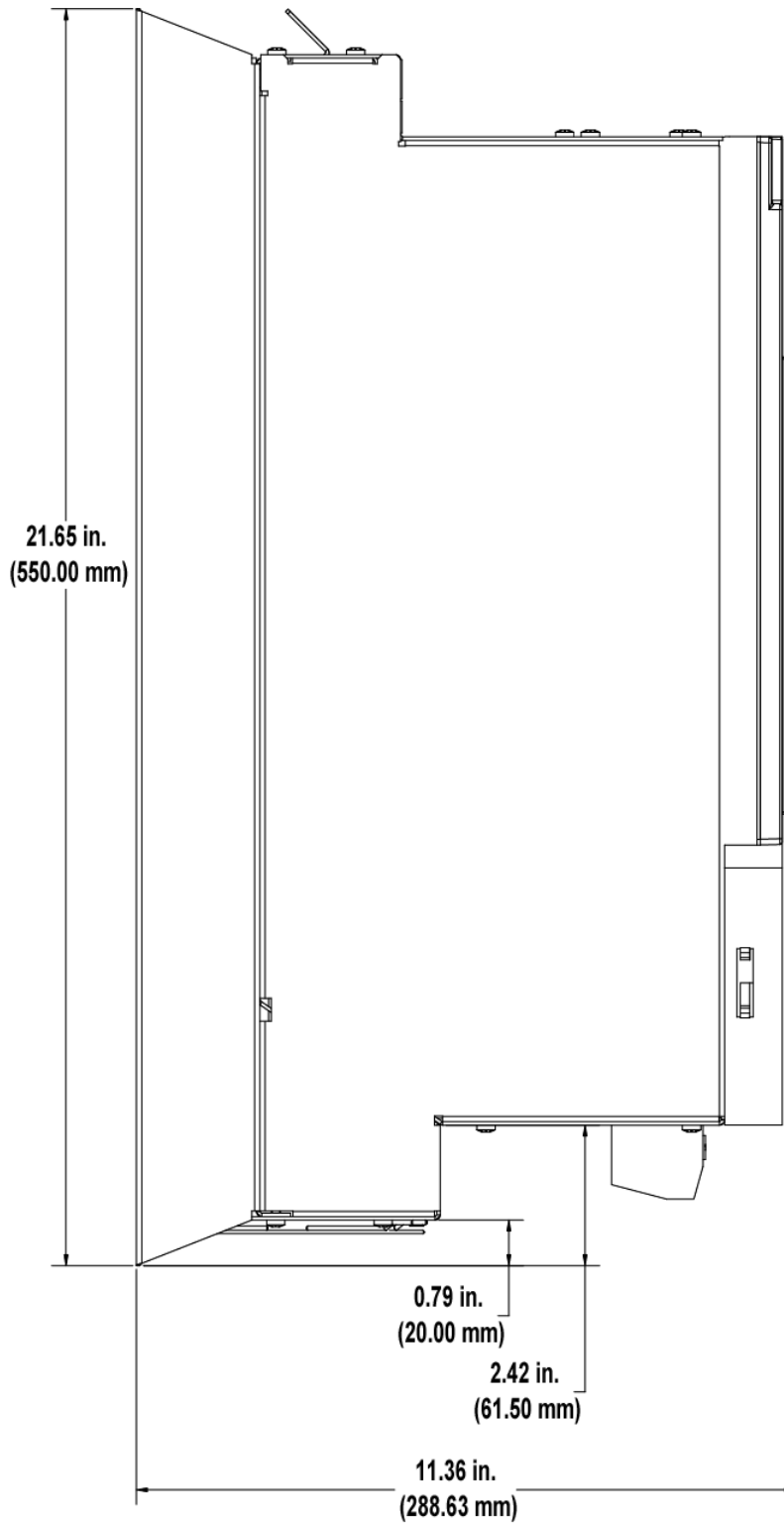

7 Cables and Connections to External Devices

7.1 I/O Cable Pin Assignments

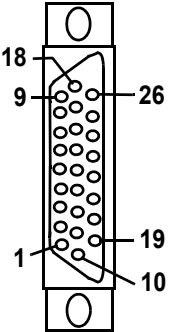
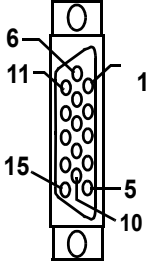
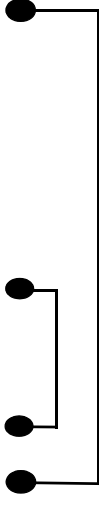
Table 7-1: I/O Cable to Controller (Analog Interfaced MMC-SD only)					
Twisted Pair 9 pair 28 AWG	D-sub 26-Pin HD Male Connector to MMC Smart Drive		D-sub 15-Pin HD Male Connector to MMC Controller		
					
Wire Color	Pin Number	SignalType	Pin Number	Jumper Connection	Signal Type
Black	1	A	1		A
White/Black	2	A/	2		DCIN+
Red	3	B	3		DCIN-
White/Red	4	B/	4		DA+
Green	5	I	5		DA-
White/Green	6	I/	10		DCOUT1
Orange	26	OUT4	6		DCOUT2
White/Orange	N/U	N/U	7		N/A
Blue	14	CMD+	8		DCOSS
White/Blue	15	CMD-	9		N/A
Yellow	17	IN1	13		N/A
White/Yellow	18	IN2	14		24VDCOUT
Brown	N/U	N/U	N/U		COM
White/Brown	N/U	N/U	15		
Violet	N/U	N/U	N/U		
White/Violet	N/U	N/U	N/U		
Gray	10	IO24V	11		
White/Gray	16	IOCOM	12		

7.2 LSM and MSM Motors Cable Pin Assignments

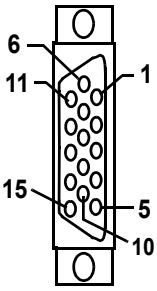
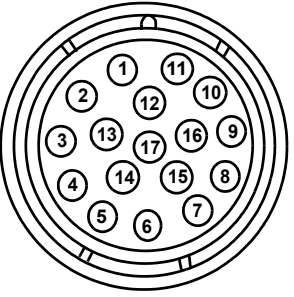

Table 7-2: F1/F2 Motor Encoder Cable to LSM or MSM Motors					
Twisted Pair 8 pair 28 AWG 1 pair 16 AWG	D-sub 15-Pin HD Male Connector to MMC Smart Drive		Connector to Motor		
					
Wire Color	Pin Number	Signal Type	Pin Number	Jumper Connections	Signal Type
Yellow	1	A	1		A
White/Yellow	2	A/	2		A/
Blue	3	B	3		B
White/Blue	4	B/	4		B/
Black	5	I	5		I
White/Black	10	I/	6		I/
Violet	12	S1	15		S1
White/Violet	13	S2	16		S2
Red	8	S3	17		S3
White/Red	N/U	N/A	N/U		N/A
Green	11	TEMPERATURE	13		TEMPERATURE+
White/Green	N/U	N/A	14		TEMPERATURE-
Orange	N/U	N/A	N/U		N/A
White/Orange	N/U	N/A	N/U		N/A
Brown	7	9 VDC	9		9 VDC
White/Brown	N/U	N/A	N/U		N/A
Gray	14	+5 VDC	10		+5 VDC
White/Gray	6	COM	11	COM	
N/C	9	N/A	7	N/C	
N/C	15	N/A	8	N/C	
			12	N/C	

Table 7-3: Motor Power Connector to LSM or MSM Motors



			Pin Number			
						
Wire Color	Wire Number	Signal Type	Size 1 Power Connector (Kit No. M.1302.0479)	Size 1.5.1 Power Connector (Kit No. M.1302.1998)	Size 1.5.2 Power Connector (Kit No. M.1302.2354)	
Black (1)	1U2	Out	1		U	
Black (2)	1V2	Out	3		V	
Black (3)	1W2	Out	4		W	
Green/ Yellow	PE	Ground	2			
Black (5)	Brake+	Out	A		+	
Black (6)	Brake-	Out	B		-	

Table 7-4: Fan Motor Power Connector to LSM or MSM Motors

				Pin Number
				
Wire Color	Wire Number	Signal Type		Pin
Brown	U	Out		1
Black	N	Out		2
Green/Yellow	PE	Ground		3

7.3 XSM Motors Cable Pin Assignments

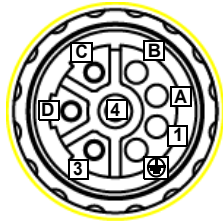
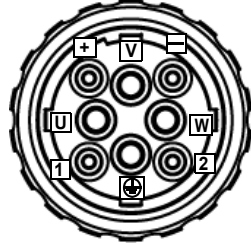
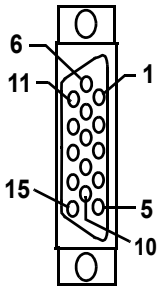
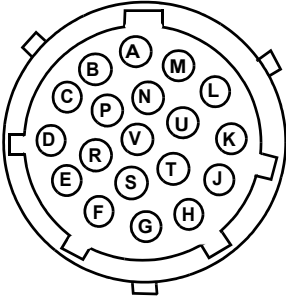
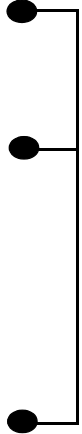
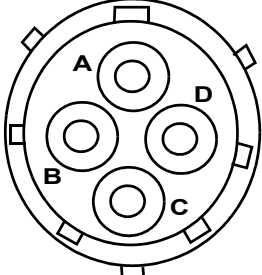

Table 7-5: F1/F2 Motor Encoder Cable to XSM Motors					
Twisted Pair 28 AWG 16 AWG	D-sub 15-Pin HD Male Connector to MMC Smart Drive 		Connector to Motor 		
	Wire Color	Pin Number	Signal Type	Pin Number	Jumper Connections
Black	1	A	A		A or SIN+
White/Black	2	A/	B		A/ or SIN-
Red	3	B	C		B or COS+
White/Red	4	B/	D		B/ COS-
Green	5	I	E		I or DATA+
White/Green	10	I/	F		I/ or DATA-
Violet	14	+5V	K		+5V
White/Violet	6	COM	L		COM
Orange	7	+9V	N		+9V
White/Orange	11	TEMPERATURE	R		TEMPERATURE+
Blue	N/U	N/A	S		TEMPERATURE-
White/Blue	12	S1	T		S1
Yellow	13	S2	U		S2
White/Yellow	8	S3	V		S3
Brown	9	TRAVEL LIMIT+	J		+LIMIT
White/Brown	15	TRAVEL LIMIT-	M	-LIMIT	
	N/A	N/A	P	COM	
	N/A	N/A	G	N/C	
	N/A	N/A	H	N/C	

Table 7-6: Motor Power Cable to XSM Motors

Table 7-6: Motor Power Cable to XSM Motors				
				
		Drive Lower Screw Terminal	Connector End to Motor	
Wire Color	Terminal	Signal Type	Pin Number	Signal Type
Brown	U	Out	A	Out
Black	V	Out	B	Out
Blue	W	Out	C	Out
Green/Yellow		Ground	D	Ground

Motor Brake Cable Connector to LSM or MSM Motors

Motor Brake Cable Connector to LSM or MSM Motors	
	
Pin Number	Signal Type
A	B+
B (N/U)	N/A
C	B-
D (N/U)	N/A

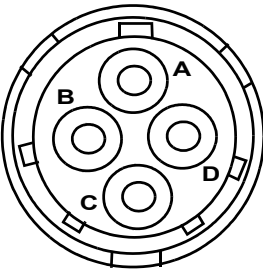
7.4 NSM Motors Cable Pin Assignments

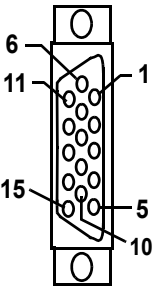
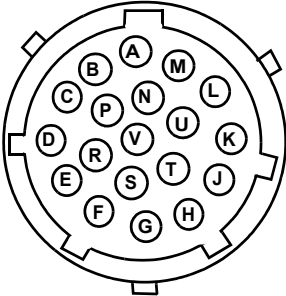
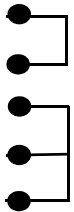
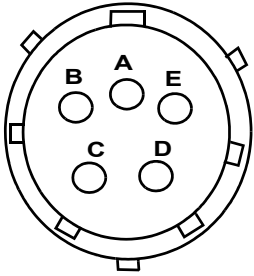

Table 7-7: F1/F2 Motor Encoder Cable to NSM Motors					
Twisted Pair 28 AWG 16 AWG	D-sub 15-Pin HD Male Connector to MMC Smart Drive		Connector to Motor		
					
Wire Color	Pin Number	Signal Type	Pin Number	Jumper Connections	SignalType
Black	1	A	A		A
White/Black	2	A/	B		A/
Red	3	B	C		B
White/Red	4	B/	D		B/
Green	5	I	E		I
White/Green	10	I/	F		I/
Gray	14	+5V	J		+5VDC
White/Gray	6	COM	K		+5VDC
			L		COM
			M		COM
Blue	13	S2	U		TEMPERATURE-
	White/Blue	12	S1		T
Brown	8	S3	V		S3
	White/Brown	11	TEMPERATURE+		R
Orange	N/U	N/A	N/U		N/A
White/Orange	N/U	N/A	N/U	N/A	
Violet	N/U	N/C	G	N/C	
White/Violet	7	N/C	H	N/C	
Yellow	9	N/C	N	N/C	
White/Yellow	15	N/C	P	N/C	

Table 7-8: Motor Power Cable to NSM Motors

				
Wire Color	Terminal	Signal Type	Pin Number	Signal Type
Brown	U	Out	A	Out
Black	V	Out	B	Out
Blue	W	Out	C	Out
Green/Yellow		Ground	D	Ground
N/A	N/C	N/A	E (N/C)	N/A

Motor Brake Cable Connector to NSM Motors

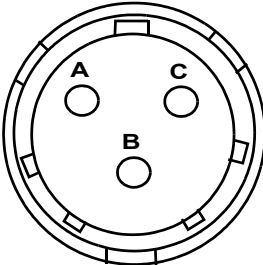

	
Pin Number	Signal Type
A	B+
B	B-
C (N/U)	N/A

7.5 HSM and FSM Motors Cable Pin Assignments

Table 7-9: F1/F2 Motor Encoder Cable to HSM and FSM Motors

Wire Color	Pin Number	Signal Type	Pin Number	Jumper Connections	Signal Type
Black	1	A	A		A
White/Black	2	A/	B		A/
Red	3	B	C		B
White/Red	4	B/	D		B/
Green	5	I	E		I
White/Green	10	I/	F		I/
Gray	14	+5V	J		+5VDC
White/Gray	6	COM	K		+5VDC
			L		COM
			M		COM
Blue	13	S2	N		TEMPERATURE-
	White/Blue	12	S1		S2
Brown	8	S3	P		S1
White/Brown	11	TEMPERATURE+	R		S3
Orange	N/U	N/A	N/U		TEMPERATURE+
White/Orange	N/U	N/A	N/U	N/A	
Violet	N/U	N/C	G	N/A	
White/Violet	7	N/C	H	N/C	
Yellow	9	N/C	N/U	N/C	
White/Yellow	15	N/C	N/U	N/A	

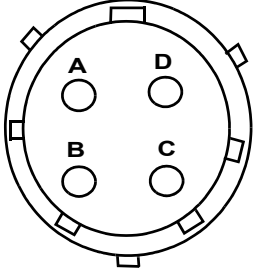
Table 7-10: Motor Power Cable to HSM and FSM Motors

					
					Drive Lower Screw Terminal
Wire Color	Terminal	Signal Type	Pin Number	Signal Type	
Brown	U	Out	A	Out	
Black	V	Out	B	Out	
Blue	W	Out	C	Out	
Green/Yellow		Ground	D	Ground	

Motor Brake Cable Connector to HSM and FSM Motors

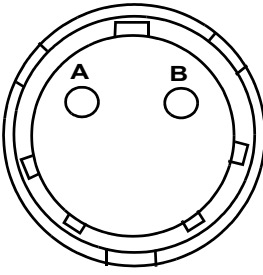
	
A	B+
B	B-

7.6 YSM Motors Cable Pin Assignments

Table 7-11: F1/F2 Motor Encoder Cable to YSM Motors

Twisted Pair 28 AWG 16 AWG		D-sub 15-Pin HD Male Connector to MMC Smart Drive		Connector to Motor	
		Pin Number	Signal Type	Pin Number	Signal Type
Black	1	A	9	NO JUMPERED PINS	A
White/Black	2	A/	10		A/
Red	3	B	11		B
White/Red	4	B/	12		B/
Green	5	I	13		I
White/Green	10	I/	14		I/
Gray	14	+5V	22		+5VDC
White/Gray	6	COM	23		COM
Blue	13	S2	17		S2
White/Blue	12	S1	15		S1
Brown	8	S3	19		S3
White/Brown	11	N/C	24		N/C
	7	N/C	1		N/C
	9	N/C	2		N/C
	15	N/C	3		N/C
			4	N/C	
			5	N/C	
			6	N/C	
			7	N/C	
			8	N/C	
			16	N/C	
			18	N/C	
			20	N/C	
			21	N/C	
			25-28	N/C	

Table 7-12: Motor Power and Brake Cable to YSM Motors					
					
		Drive Lower Screw Terminal		Connector End to Motor	
Wire Color	Terminal	Signal Type	Pin Number	Signal Type	
Brown	U	Out	1	Out	
Black	V	Out	2	Out	
Blue	W	Out	3	Out	
N/A	N/U	N/A	4 (N/U)	N/A	
Green/Yellow	⊕	Ground	5	Ground	
N/A	N/U	N/A	6 (N/U)	N/A	
N/A	N/U	N/A	8 (N/U)	N/A	

Table 7-13: Motor Brake Cable Connector to YSM Motors	
Pin Number	Signal Type
7	B+
9	B-

7.7 Connecting Shunt Modules

Use shielded, high temperature 75° C (167° F), 600V, 2.5-4.0 mm² (12-14 AWG), 3.05 m (10 ft) maximum, copper wire. Follow one of the methods given below to reduce the effects of EMI noise:

- Install wires using twisted pairs (two turns per foot minimum), as shown in the figure above. Keep unshielded wires as short as possible.
- Use shielded, twisted cable (ground shield at shunt and drive).
- Use shielded metal conduit (ground conduit at shunt and drive).

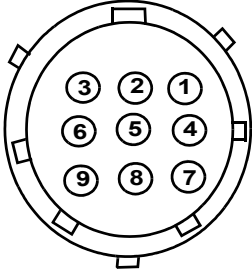
When two shunt modules are connected in parallel, the shunt capacity is doubled.

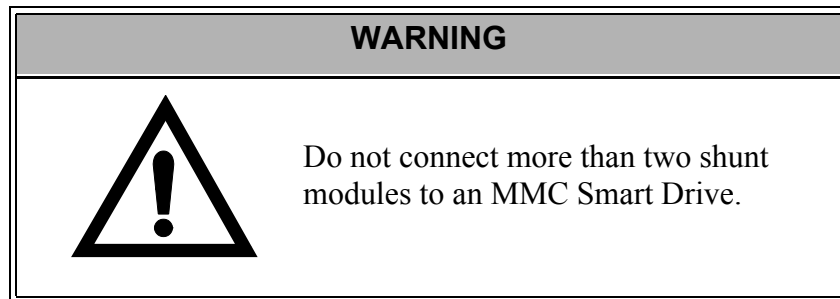

7.7.1 Connecting the 230V MMC Smart Drive to 300 W Shunt Module

Figure 7-1: Wiring 230V MMC Smart Drive to 300W Active Shunt Module

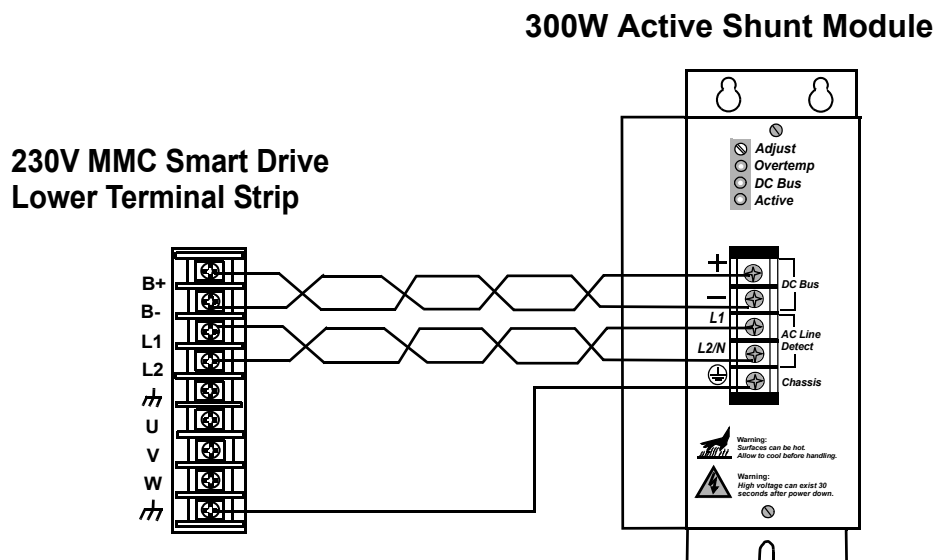

7.7.2 Connecting the 460V MMC Smart Drive to G&L Motion Control Shunt Modules

Figure 7-2: Wiring 460V MMC Smart Drive to 450 Watt, 130Ω Shunt Module / 700 Watt, 95Ω Shunt Module / 1400 Watt, 50Ω Shunt Module

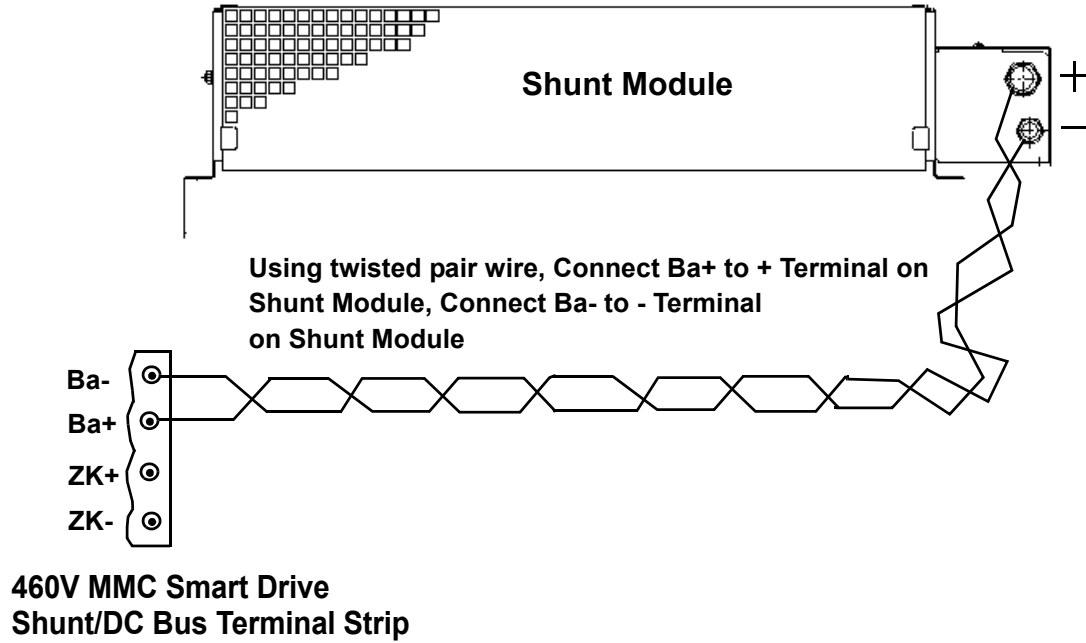
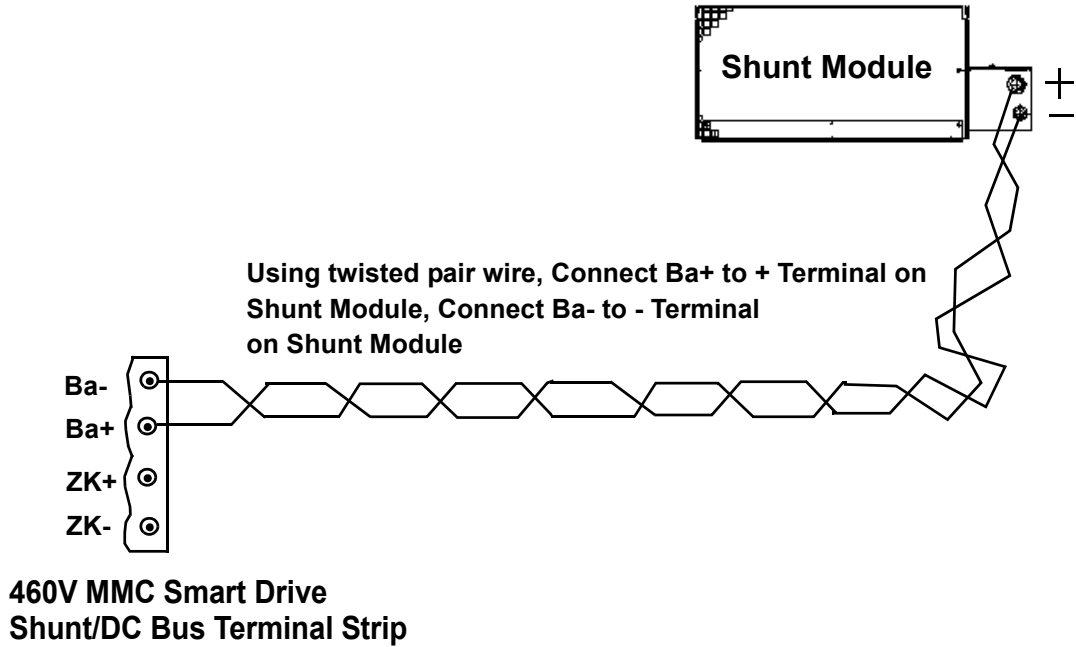
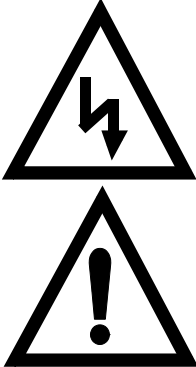

Figure 7-3: Wiring 460V MMC Smart Drive to 2800 Watt, 25Ω Shunt Module / 3900 Watt, 18Ω Shunt Module



8 Maintenance and Troubleshooting

8.1 Maintenance

WARNING	
	<p>Disconnect input power before touching cables or connections.</p> <p>DC bus capacitors may retain hazardous voltages after input power has been removed.</p> <p>Before working on the drive, measure the DC bus voltage to verify it has reached a safe level.</p> <p>Failure to observe this precaution could result in severe bodily injury or loss of life.</p>

1. Remove superficial dust and dirt from the drive.
2. Check cable insulation and connections.
3. Clean exterior surfaces and airflow vents using an OSHA approved nozzle that provides compressed air under low pressure of less than 20 kPa (30 psi).
4. Visually check for cable damage. Replace all damaged cables.
5. Inspect D-shell connectors for proper seating and signal continuity end-to-end.

8.2 Diagnostics

8.2.1 Power-On Diagnostics

When the drive is powered up, it tests itself and reports the results of the tests in the form of LED signals.

8.2.1.1 Power LED

If the Power (P) LED does not go on, or goes off during operation of the system, check that 24 VDC power is still connected to the drive.

8.2.1.2 Diagnostic LEDs

The Status LED (D1) lights up briefly while diagnostic tests are running and then goes off. If the Status LED (D1) remains on, the drive has failed one of its diagnostic tests. Follow these steps:

1. Turn off power to the drive system and to the application.
2. Perform any necessary maintenance to the drive.
3. Check the I/O wiring and the devices the system is connected to. There may be a short or other problem other than the drive. Correct these problems.
4. Turn on power to check diagnostics again.

Power-On diagnostics are run only when the system is powered up. If a drive fails during power-up, the Status LED (D1) light remains on. If you suspect that a drive is defective, cycle power to run diagnostics again.

8.2.2 Run-Time Diagnostics

While the MMC Smart Drive is running, other tests are performed on a regular basis with their results also reported through the Status LED (D1).

While the MMC Smart Drive is running, the Status LED (D1) will flash a two digit code signal if there is an error. The errors are described in Table 8-2: Drive Diagnostic LED Error Codes.

8.3 Troubleshooting

8.3.1 General Troubleshooting

Table 8-1: General Troubleshooting Symptoms, Causes, Remedies

Symptom	Possible Cause	Remedy
Power (P) indicator not ON	No 24VDC input power. Internal power supply malfunction.	Verify 24 VDC power is applied to the drive. Contact your G&L Motion Control representative.
Motor jumps when first enabled	Motor wiring error. Incorrect motor chosen. Incorrect or faulty encoder	Check motor feedback and power wiring. Verify the proper motor is selected. Replace the encoder with correct and/or functional encoder.
I/O not working correctly	I/O power supply disconnected.	Verify connections and I/O power source.

8.3.2 Troubleshooting Drive Diagnostic Error Codes

When an error is detected the Status LED (D1) located above the PiCPro port on the face of the drive will flash a two-digit error code. The LED will continue to flash until the error is eliminated.

For example, if there is a long pause-flash-pause-flash-flash-long pause, the code is 12. The Diagnostic Error Codes are described in Table 8-2: Drive Diagnostic LED Error Codes.

Table 8-2:

Fault Code	Fault	Possible Causes	Possible Remedies
11	Drive Memory Fault	The drive's non-volatile memory is not functioning properly	Upgrade firmware. Contact G&L Motion Control.
12	Drive Bus Over Voltage Fault	Excessive regeneration of power. The motor may regenerate too much peak energy through the drive's power supply. A fault is generated to prevent overload.	Change the deceleration or motion profile. Check shunt connections and where necessary, properly make connections. Reduce the reflected inertia of your mechanical system. Use a larger motor and/or drive.
		Excessive AC input voltage.	Verify input AC voltage is within specifications. Adjust accordingly.
		Output short circuit.	Remove all power and motor connections, and perform a continuity check from the DC bus to the U, V, and W motor outputs. If a continuity exists, check for wire fibers between terminals, contact G&L Motion Control
		Motor cabling wires shorted together.	Disconnect motor power cables from the drive. Test the cables for short circuits. Replace cable if necessary.
		Internal motor winding short circuit.	Disconnect motor power cables from the motor. If the motor is difficult to turn by hand, it may need to be replaced. Test winding resistance to confirm short circuit.
		230V motor used with a 460V drive and drive powered at 460V.	Set the drive for operation at 230V and apply 230V power to the drive.

13	Drive PM1 Over Current Fault	Current feedback exceeds the drive over current fault limit.	Adjust the over current fault limit.
		Output short circuit.	Remove all power and motor connections, and perform a continuity check from the DC bus to the U, V, and W motor outputs. If a short exists, check for wire fibers between terminals, contact G&L Motion Control
		Motor cabling wires shorted together.	Disconnect motor power cables from the drive. If faults stop, replace cable.
		Internal motor winding short circuit.	Disconnect motor power cables from the motor. If the motor is difficult to turn by hand, it may need to be replaced.
14	Drive Over Power Fault	Drive current and voltage output, in combination with the heatsink temperature indicate that the power output required by the drive would damage the power section.	Verify ambient temperature is not too high. Operate within the continuous power rating. Reduce acceleration rates. Check for mechanical load problems and adjust as necessary. Resize the application and apply components accordingly.
15	Motor Temperature Fault	Motor thermostat trips due to high motor ambient temperature	Operate within (not above) the continuous torque rating for the ambient temperature (40°C maximum). Lower ambient temperature, increase motor cooling. Check that motor is properly sized for the application. If necessary, resize the motor.
		Motor thermostat trips due to excessive current	Reduce acceleration rates. Increase time permitted for motion. Use larger drive and motor. Reduce duty cycle (ON/OFF) of commanded motion. Check tuning.
		Motor thermostat trips due to motor wiring error.	Check motor wiring.
		Motor thermostat trips due to incorrect motor selection.	Verify the proper motor has been selected.
16	Continuous Current Fault	Current exceeds the continuous motor current rating for an extended period of time.	Change motor and or drive to be compatible with load requirements. Check tuning.
17	Drive Heatsink Temperature Fault	Drive heatsink temperature exceeds drive heatsink fault limit	Let the drive cool down and/or reduce the load.

Troubleshooting

22	Drive F1 Feedback Fault	Error is detected in the motor feedback	Verify motor selection is correct. Check to be sure the correct encoder is attached. Verify encoder wiring is correct. Use shielded cables with twisted pair wires. Route the encoder feedback cable away from potential noise sources. Check ground connections.
23	Drive Ambient Temp. Fault	Drive ambient temperature exceeds the drive ambient temperature fault limit	Operate within (not above) the continuous rating for the ambient temperature. Lower ambient temperature, increase cabinet cooling.
24	Motor Calculated Temp. Fault	Motor calculated temperature exceeds the motor calculated temperature fault limit.	Check the machine for excessive loads. Motor may be undersized for the application.
25	Drive Timing Fault	Timing error is detected in the execution of the control algorithms performed by the drive's digital signal processor.	Contact G&L Motion Control.
26	Drive Interface Fault	Communication error is detected in the transmission of information between the drive's digital signal processor and the drive's power section.	Contact G&L Motion Control.
27	User Set Fault	PiCPro Set User Fault command selected.	The PiCPro Set User Fault command was selected or the Control Panel mode was activated or deactivated while the drive was enabled.
31	Drive F1 Communication Fault	Communication error is detected in the transmission of information between the drive and a high resolution or multi-turn absolute feedback device.	Check encoder line and make sure the correct encoder is attached. Verify encoder wiring is correct. Use shielded cables with twisted pair wires. Route the encoder feedback cable away from potential noise sources. Check ground connections. Verify motor selection is correct.
		Bad encoder.	Replace motor and encoder.
32	Over Speed Fault	User specified motor speed has been exceeded.	Check cables for noise. Check tuning.
33	Over Current Fault	User-Specified average current level has been exceeded.	Change to a less restrictive setting. Reduce the load.
34	Drive Communication Fault	Communication error occurs while drive control is being performed using the PiCPro Control Panel tools.	Do not disconnect the PiCPro cable while operating in Control Panel Mode.

35	Drive Power Module Fault	The drive's power section detects a fault condition.	Verify AC power is applied to drive. Contact G&L Motion Control.
36	Drive Setup Data Fault	The configuration data has been corrupted.	Re-download Drive Setup Data.
41	Drive Relay Fault	The drive's power section relay did not function properly during power-up.	Check the drive system connections. Adjust as necessary. Contact G&L Motion Control.
42	Drive PM2 Over Current Fault	Current feedback exceeds the drive over current fault limit.	Adjust the over current fault limit.
		Output short circuit.	Remove all power and motor connections, and perform a continuity check from the DC bus to the U, V, and W motor outputs. If a continuity exists, check for wire fibers between terminals, contact G&L Motion Control.
		Motor cabling wires shorted together.	Disconnect motor power cables from the drive. If faults stop, replace cable.
		Internal motor winding short circuit.	Disconnect motor power cables from the motor. If the motor is difficult to turn by hand, it may need to be replaced.
43	Drive PM Over Temperature Fault	Drive power module temperature exceeds the drive power module temperature fault limit	Check to be sure that the drive is being operated within the continuous power rating. Check for adequate enclosure ventilation. Ensure cooling air flow is adequate in space around the drive. Check for clogged vents or defective fan. Contact G&L Motion Control.
44	Motor Ground Fault	Ground fault has occurred.	Make sure motor ground connections are correct. Replace defective motor ground wires. Check for internal motor winding short circuits.
45	Drive AC Input Over Voltage Fault	Incoming AC voltage is too high.	Verify input VAC is within specifications.

Troubleshooting

46	Overtravel Plus Fault	Overtravel Plus Fault input is off and Drive Ignore Plus Travel Limit is off.	Overtravel Plus Fault status can be monitored using READ_SV variable 68 AND (16#400 0000). Fault input write a 0 to WRITE_SV variable 86. Use DRSETFLT to reset fault indications. To override the Overtravel Plus Fault input write a 1 to WRITE_SV variable 86, Ignore Plus Travel Limit. To reactivate checking of the Overtravel Plus input write a 1 to WRITE_SV variable 86, Ignore Plus Travel Limit. To reactivate checking of the Overtravel Plus Fault input write a 0 to WRITE_SV variable 86.
47	Overtravel Minus Fault	This fault is set when the Overtravel Minus Fault input is off and Drive Ignore Minus Travel Limit is off.	Overtravel Minus Fault status can be monitored using READ_SV variable 68 AND (16#800 0000). Use DRSETFLT to reset fault indications. To override the Overtravel Minus Fault input write a 1 to WRITE_SV variable 87, Ignore Minus Travel Limit. To reactivate checking of the Overtravel Minus Fault input write a 0 to WRITE_SV variable 87.
51	Digital Link Communication Error	This fault is set when two consecutive corrupt Digital Link messages are detected or no Digital Link messages are received within 250 microseconds.	Digital Link Communication Error status can be monitored using READ_SV variable 68 AND (16#1000 0000). This fault requires that the user servo setup function and DSTRTSRV be executed prior to executing DRSETFLT to reset the fault indication.
52	Invalid Switch Setting Fault	This fault is set when the drive address switch setting is set to 0 or greater than 64 or its setting is changed while the Digital Link is operating in cyclic communications mode.	Invalid Switch Setting Fault status can be monitored using READ_SV variable 68 AND (16#2000 0000). Use DRSETFLT to reset fault indications. Note: Digital Link initialization must be performed before this fault can be reset.
77	Drive Not Ready	Power applied to an uninitialized drive.	Initialize and configure the drive using PiCPro.

8.3.3 Troubleshooting Warning Error Codes

Table 8-3:

Error Code	Warning	Possible Causes	Possible Remedies
01	Drive Heatsink Temp. Warning	Drive heatsink temperature exceeds warning limit	TBD
02	Drive Ambient Temp. Warning	Acceptable ambient temperature limit has been exceeded warning limit	TBD
03	Motor Temp. Warning	Motor thermal device is a thermistor and thermistor temperature has exceeded acceptable limit	<ul style="list-style-type: none"> • Reduce acceleration rates. • Reduce duty cycle (ON/OFF) of commanded motion. • Increase time permitted for motion. • Use larger drive and motor. • Check tuning.
04	Motor Calculated Temp. Warning	Calculated motor temperature has exceeded acceptable limit	TBD

9 Resolver Interface Option Module

9.1 Theory of Operation

The Resolver Interface Option Module provides the interface between the resolver and the drive's DSP. It is a tracking system where the rotor is excited with a sine wave. The outputs of the resolver are amplitude modulated by the sine and cosine of the rotor shaft angle. The tracking converter converts the sine and cosine amplitude ratio into a 12 bit number.

The module provides a 4 Vrms 5 kHz sine wave to excite the resolver rotor. The resolver transformer ratio is .5:1 so the stator outputs are 2V RMS with the shaft rotated to the angle of maximum coupling. The sine and cosine rotor outputs are returned to the resolver module's twin instrumentation amplifier inputs to produce a high common mode noise rejection and a high input impedance (220K Ω). The sine and cosine signals are then fed to a resolver to digital converter chip that performs the tracking conversion. The converter has both a serial output and an encoder emulator output. The serial output is read when the drive is powered up to obtain the absolute commutation angle for the motor. Thereafter, it is used as an encoder emulator.

The module is able to detect a loss of feedback by monitoring the sine and cosine signals. If both are near zero at the same time, a loss of feedback error is generated.

9.2 Installing the Resolver Module

1. Remove the five screws at the corners of the face of the 230V drive or loosen the 2 mounting screws on the face of the 460V drive.
2. Remove the shunt from the 24-pin DIP socket located on the MMC Smart Drive board.
3. Position the Resolver Option Module so the standoffs align with the mounting holes on the MMC Smart Drive board, and the header is aligned with the socket.
4. Using even pressure, press the option module into place.
5. Verify that the module is fully seated into the socket and the locking tabs on the standoffs are in the locked position.

Figure 9-1: Before Shunt Removed and Resolver Module Installed

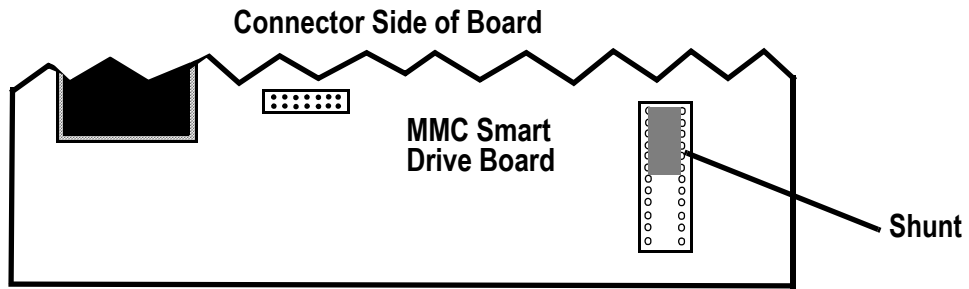
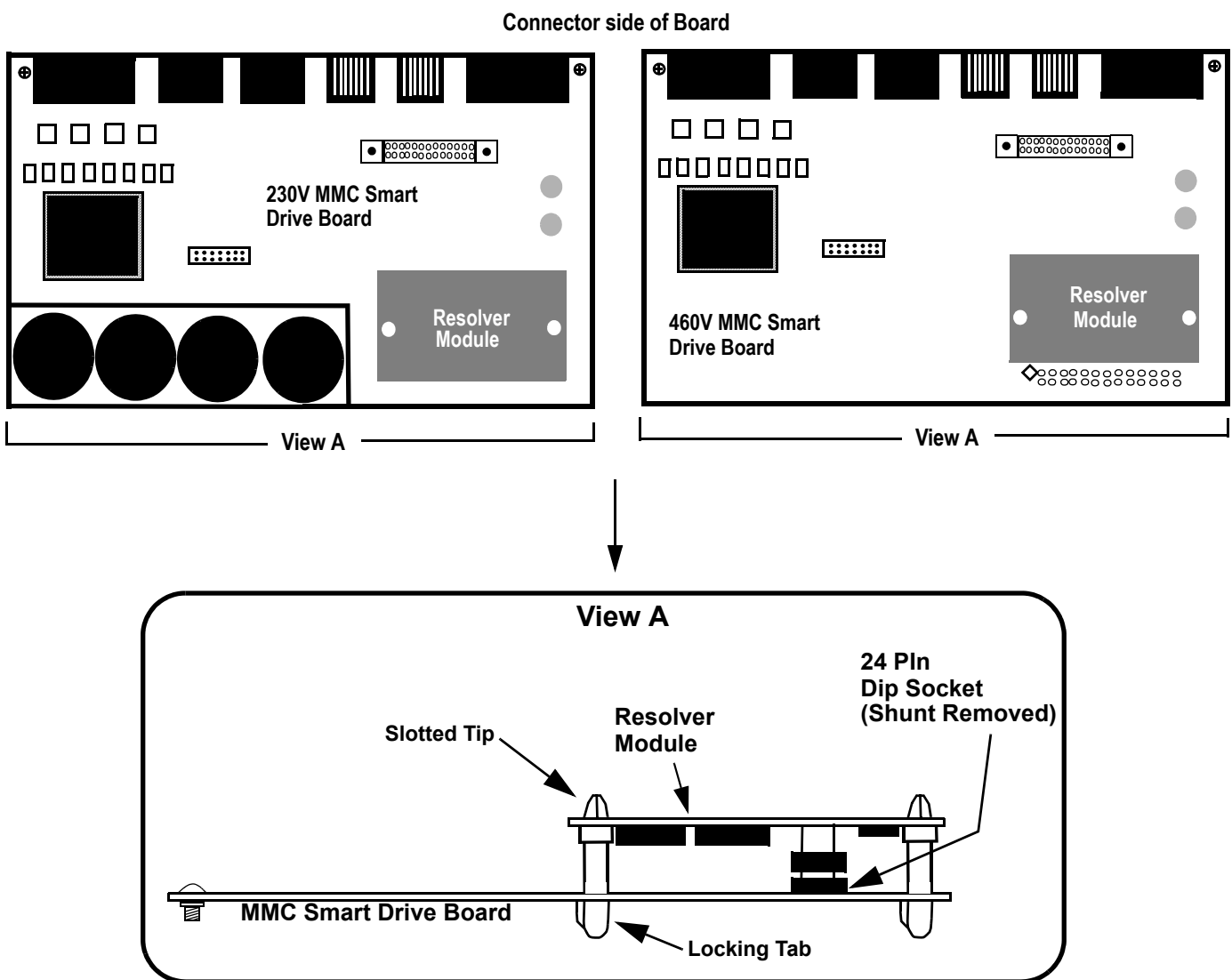

Figure 9-2: Shunt Removed and Resolver Module Installed



9.3 Specifications

Characteristics	Resolver Interface Option Module Specifications
Function	Resolver to encoder converter
Part Number	M.1302.4523
Field Side Connector	F1 Feedback Connector
Excitation Frequency	5 kHz
Output Voltage	4 V _{RMS}
Current per Output Channel, max.	28 mA _{RMS}
Resolver Transformer Ratio	0.5:1.0
Resolver Resolution	4096 Feedback Units (FUs) per electrical revolution
Accuracy Over Temperature Range	± 15 minutes
Electrical Velocity, max.	500 RPS
Cable Length, max.	30 M
Power	Powered from MMC Smart Drive

10 MMC Smart Drive Control

10.1 Introduction

This section contains information for the MMC Smart Drive Control (Digital MMC-Dx). Block I/O information can be found in the Block I/O Modules Manual. Software information can be found in the PiCPro Online Help, the Function/Function Block Reference Guide, ASFB Manuals or on-line.

10.1.1 Overview

The MMC Smart Drive Control offers a complete solution to both machine and motion control in a module that is installed into any Digital Interfaced Smart Drive (MMC-SD-D). One MMC Smart Drive Control can control from 1 to 16 drives as follows:

- Digital MMC-D1 (controls one MMC-SD-D)
- Digital MMC- D2 (controls two MMC-SD-D)
- Digital MMC- D4 (controls four MMC-SD-D)
- Digital MMC- D16 (controls 16 MMC-SD-D)

The PiCPro programming tool used with the PiC family of controls is also used to program the MMC Smart Drive Control. The built-in I/O [8 inputs (24 VDC) and 8 outputs (24 VDC)] can be expanded using G&L Motion Control serially distributed block I/O (not included on the Digital MMC-D1) .

10.1.2 Major Components

The MMC Smart Drive Control contains the CPU, a user serial port, a Block I/O port, and a general I/O port consisting of 8 DC inputs and 8 DC outputs.

Figure 1: The MMC Smart Drive Control

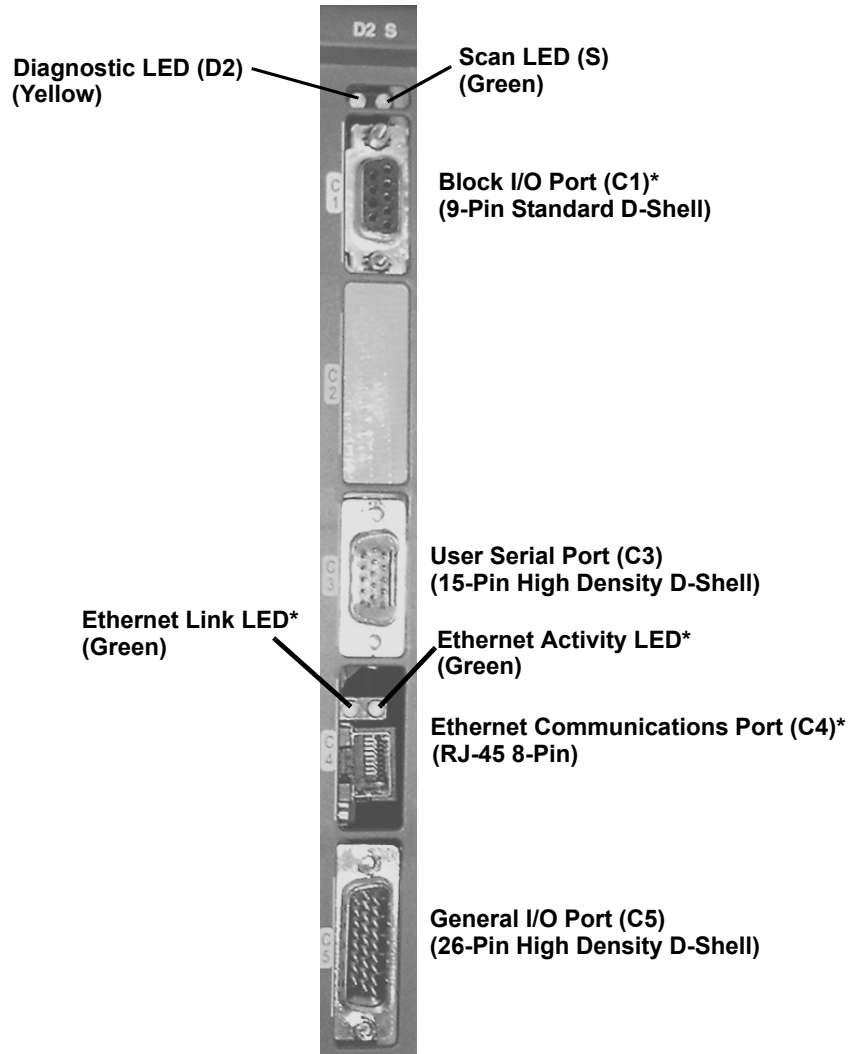

* The Block I/O Port connector (C1), Ethernet Communications Port connector (C4), Ethernet Link LED, and Ethernet Activity LED are present on the Digital MMC-D1 Control, but are not functional.

10.2 Installing the MMC Smart Drive Control

10.2.1 Installing the MMC Smart Drive Control into a Digital Interfaced 230V MMC-SD Drive

1. Remove the three screws from the right side of the cover and one screw from the top and bottom of the drive near the front. Remove the cover.
2. Place the cover removed in step 1 on a flat surface, with the blue plastic faceplate down, and the large side cover to the left pointing up.
3. Remove the two screws that hold the .6" by 8" blue filler plate to the back of the faceplate and remove the plate.
4. Locate the 4 screws that secure the top-most printed circuit board into the drive. Remove one of the screws and the associated lockwasher, and install one of the four threaded standoffs that were included with the MMC Smart Drive Control (do not use the lockwasher). Repeat this process for the other 3 screws, one at a time.
5. Place the MMC Smart Drive Control into the drive, with the connectors facing towards the front of the unit. Align the 20-pin connector on the MMC Smart Drive Control with the 20-pin connector on the drive. Press the MMC Smart Drive Control onto the drive until the 20-pin connector is completely seated and the MMC Smart Drive Control is seated against the threaded standoffs installed in step 4.
6. Fasten the MMC Smart Drive Control onto the threaded standoffs using the lockwashers and screws removed in step 4.
7. Replace the cover using the 4 screws removed in step 1.

10.2.2 Installing the MMC Smart Drive Control into a Digital Interfaced 460V MMC-SD Drive

1. Turn the two locking screws on the front of the drive clockwise $\frac{1}{4}$ turn and pull the drive control board unit out of the drive.
2. Place the drive control board unit removed in step 1 on a flat surface, with the blue plastic faceplate down, and the drive control board to the left.
3. Remove the two screws that hold the .6" by 8" blue filler plate and remove the plate.
4. Place the drive control board unit on a flat surface so that the control board is facing up, and the blue plastic faceplate is facing away from you.
5. Locate the 4 screws that secure the top-most printed circuit board into the drive. Remove one of the screws and the associated lockwasher, and install one of the four threaded standoffs that were included with the MMC Smart Drive Control (do not use the lockwasher). Repeat this process for the other 3 screws, one at a time.
6. Place the control board unit on a flat surface, with the blue plastic faceplate down, and the drive control board to the left.
7. Loosen (but do not remove...about 2 turns) the 5 screws that hold the drive control board mounting plate to the front cover plate.
8. Place the MMC Smart Drive Control into the drive, inserting the connectors on the MMC Smart Drive Control through the front plate.
9. Align the 20-pin connector on the MMC Smart Drive Control with the 20-pin connector on the drive. Press the MMC Smart Drive Control onto the drive until the 20-pin connector is completely seated and the MMC Smart Drive Control is seated against the threaded standoffs installed in step 5.
10. Tighten the 5 screws loosened in step 7
11. Fasten the MMC Smart Drive Control onto the threaded standoffs using the lockwashers and screws removed in step 5.
12. Replace the control board unit back into the drive, and turn the locking screws $\frac{1}{4}$ turn counter-clockwise to secure the unit in place.

10.3 System Wiring Guidelines

The MMC Smart Drive Control relies on electrical signals to report what is going on in the application and to send commands to it. In addition, signals are constantly being exchanged within the system. The MMC Smart Drive Control is designed for use in industrial environments, but some guidelines should be followed.

Figure 2: Recommended EMC Compliant Connections

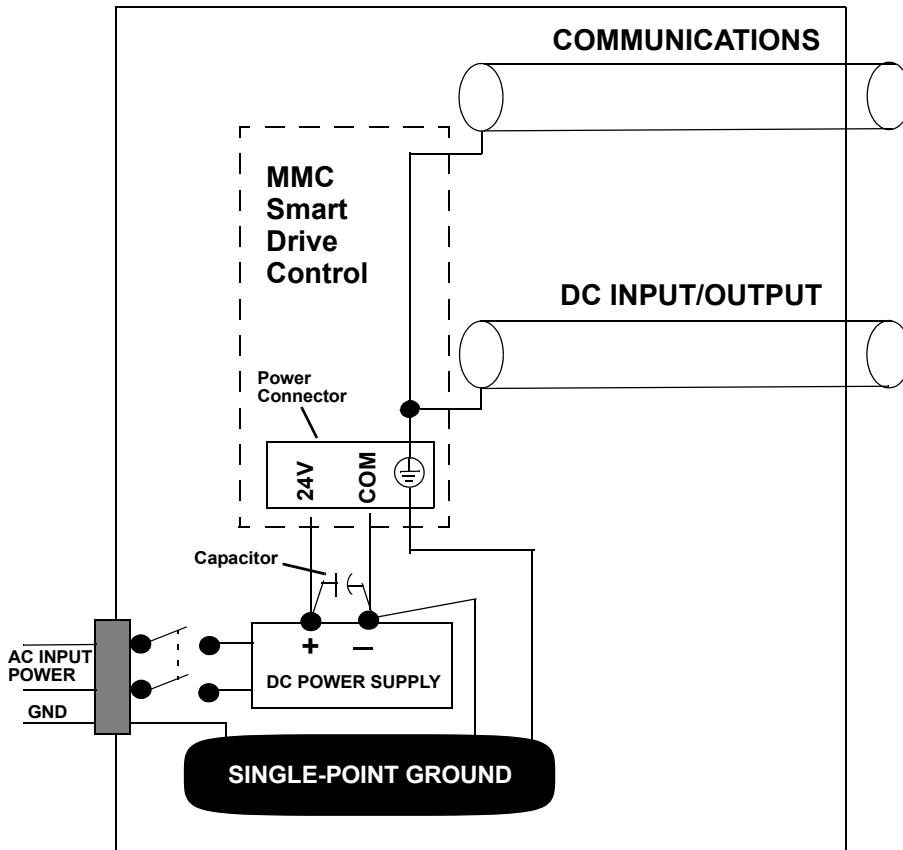

Inside a control cabinet, connect the shields of shielded cables. The two different methods of terminating shields are used to accommodate two different immunity requirements. Immunity required inside an enclosure is considered lower because cables are typically less than three meters in length and/or can be separated from each other and from noise sources.

Immunity required external to an enclosure is considered higher because the user may have less control over the noise environment. Low level signal cables that can be external to an enclosure are tested at a 2 KV level for electrical fast transients (EFTs). Low level signals that can be less than three meters in length or can be separated from noise sources are tested at a 1 KV level. Under the stated conditions, there will be no disturbance of digital I/O, encoder, or encoder operation. For analog signals, there may be momentary disturbances but there will be self-recovery when the noise subsides.

Do not operate transmitters, arc welding equipment, or other high noise radiators within one meter of an enclosure that has the door open. Continue to equip inductive devices, if they are in series with a mechanical contact or switch, with arc suppression circuits. These devices include contactors, solenoids and motors. Shield all cables that carry heavy current near the system, using continuous foil wrap or conduit grounded at both ends. Such cables include power leads for high-frequency welders and for pulse-width-modulated motor drives.

WARNING

Use care when wiring I/O devices to the MMC Smart Drive Control and when plugging in cables. Wiring the wrong device to the connector or plugging a connector into the wrong location could cause intermittent or incorrect machine operation.

10.4 Starting an Operation

Good procedure suggests that the system should be tested each time a new application is powered up. The Diagnostic LED (D2) on the MMC Smart Drive Control should be off indicating that the diagnostic tests were passed.

Turn off the main disconnect switch and plug the DC connector into the power connector on the MMC-SD. Turn on input power. The D2 LED turns on and then turns off when the MMC Smart Drive Control passes its diagnostic tests.

10.4.1 Connecting the MMC to the Application

1. Turn off the main disconnect switch in the control cabinet. If some devices are not powered from the control cabinet, turn them off also.
2. Connect the connectors according to your diagrams.
3. Turn on power to the system. The PWR light on the MMC-SD goes on and stays on.
The D2 light goes on, then goes off in turn.
The SCAN (S) light goes on.
The application starts to work under control of the system.
4. If an application program is not in system memory, use the download command in the PiCPro software to place it there.

10.4.2 Basic Setup and Maintenance Procedures

Table 1 below summarizes how to proceed when performing certain maintenance and/or setup functions.

Table 1: Troubleshooting Summary

In order to:	
Turn off the entire application.	Turn off main disconnect (which should also turn off all external power supplies to the application); unplug the DC power to the MMC-SD.
Wire the I/O to the application.	Turn off main disconnect (which should also turn off all external power supplies to the application); unplug the DC power to the MMC-SD.
Change the battery.	Turn off main disconnect (which should also turn off all external power supplies to the application); unplug the DC power to the MMC-SD.
Connect/disconnect the MMC with the computer workstation through the PiCPro port.	Turn off main disconnect (which should also turn off all external power supplies to the application); unplug the DC power to the MMC-SD.
Connect/disconnect the MMC with an operator interface through the User port.	Turn off main disconnect (which should also turn off all external power supplies to the application); unplug the DC power to the MMC-SD.
Download an application program into the memory.	Make sure power is on (check the P LED) on the MMC-SD.
Stop the scan.	From the workstation - use the Stop Scan commands in the PiCPro software.

10.4.3 Start-up Diagnostics

When the system is powered up, it tests itself and reports the results in the form of LED signals.

10.4.3.1 Power LED

If the Power LED (P) on MMC-SD does not go on, or goes off during operation of the system, check that power is still connected to the MMC-SD. If the power LED on the MMC-SD is on, turn off the main disconnect switch and replace the MMC Smart Drive Control.

10.4.3.2 Scan LED

If the SCAN (S) LED does not go on:

1. Check that the power (P) light is ON.
2. Check that the diagnostic (D2) light is OFF.

10.4.3.3 MMC Start-Up Diagnostic LEDs

The LED D2 light on the MMC Smart Drive Control lights up briefly while its diagnostic tests are running and then goes off. If D2 remains on, the MMC Smart Drive Control has failed one of its tests. Follow these steps:

1. Turn off power to the system and to the application.
2. If the I/O wiring is connected, remove the connector.
3. Remove the defective MMC Smart Drive Control from the drive.
4. Replace with a new MMC Smart Drive Control. Connect the I/O wiring.
5. Turn on power to check diagnostics again.

NOTE

Diagnostics are run only when the system is powered up. It is possible that a failure might occur during operation. If so, D2 remains off. If you suspect that a module might be defective, cycle power to run diagnostics again.

10.4.4 MMC Run-Time Diagnostics

While the MMC Smart Drive Control is running, other tests are performed on a regular basis with their results also reported by D2.

While the MMC Smart Drive Control is running, the D2 will flash a three digit code signal if there is an error. For example, if there is a long pause-flash-pause-flash-flash-pause-flash-flash-flash-long pause, the code is 123.

Code	Error	Description
123	Scan too long	A ladder scan loss has occurred because the CPU takes more than 200 ms to scan the application program. Whenever the scan light is out, the discrete outputs go to the OFF state and the analog outputs are zeroed.
124	Excessive overhead	The system overhead update time is excessive.
125	Insufficient memory	There is insufficient memory on the CPU to run the current program.
126	No hardware bit memory	There is no bit memory installed on the CPU and the program requires it.
127	No software bit memory	There is no bit memory capability via software and the program requires it.
222	Driver error	No driver support on the CPU for the I/O module. Update your system EPROMs.
22_	Master rack error	The I/O modules in the master rack do not match what was declared in the hardware master declaration table. The number of flashes in the third digit () identifies the slot number that is in error.
232	Communications error	A failure has occurred in remote I/O communications.
3__	Expansion rack error	The I/O modules in the block I/O modules do not match what was declared in the expansion hardware declaration table. For block I/O modules: The number of flashes in the second and third digits indicates the block I/O module (01 through 77). The second digit will flash a 1 - 7, 10 for 0. The third digit will flash a 1 - 9, 10 for 0. For example, if the second digit flashes 3 times and the third digit flashes 10 times, the module is 30 .

10.5 MMC Connections to External Devices for Machine Control

G&L Motion Control provides many optional accessories that simplify wiring the MMC Smart Drive Control to external devices.

These accessories include cables to connect MMC-SD drives together and breakout boxes that provide screw-terminal connections to the MMC Smart Drive Control. Contact G&L Motion Control for further information.

10.5.1 PiCPro Port (P1)

The provides serial communication for the PiCPro programming interface. PiCPro Port (P1) is physically located on the MMC-SD faceplate. Refer to Chapter 5 for information on the PiCPro (P1) Port.

10.5.2 Block I/O Port (C1)

Note: The Block I/O Port (C1) is not included on the Digital MMC-D1.

The Block I/O Port (C1) is a 9-pin female "D" connector and provides:

- Up to 77 expansion block I/O units
- 4-wire communication interface
- Up to 200 feet between block I/O units

Table 2: Pinout for Block I/O Port (C1)

Pin	Description	In/Out
1	NC	
2	NC	
3	Block I/O Transmit Data +	Out
4	Block I/O Transmit Data -	Out
5	Block I/O Receive Data +	In
6	Block I/O Receive Data -	In
7	Shield (see Note below)	
8	NC	
9	NC	

NOTE

Pin 7 of the Block I/O Port (C1) connector is connected to the connector shell within the MMC Smart Drive Control. Therefore, the shield may be connected to either pin 7 or the connector shell.

10.5.3 User Port (C3)

The User Port (C3) is a 15-pin male high density "D" connector, used to communicate with a touch-screen, a hand-held controller, or other serial interface device. The User Port (C3) provides:

- RS232/RS485 communication
- Baud rates to 115.2 K
- Multidrop capability

Table 3: Pinout for User Port (C3)

Pin	Description	In/Out	Pin	Description	In/Out
1	NC	N/A	9	RS232 Receive Data	In
2	NC	N/A	10	RS232 Transmit Data	Out
3	NC	N/A	11	NC	
4	RS232 Data Terminal Ready (3.3V)	Out	12	RS485 Receive Data +	In
5	RS232 Request to Send	Out	13	RS485 Receive Data -	In
6	NC	N/A	14	RS485 Transmit Data +	Out
7	RS232 Clear to Send	In	15	RS485 Transmit Data -	Out
8	Signal Ground	In/Out			

10.5.4 Ethernet Port (C4)

NOTE: The Ethernet Port (C4) is not included on the Digital MMC-D1.

The Ethernet Port (C4) consists of an 8-pin RJ45 connector and LEDs that provide:

- IEEE 802.3/802.3u-100Base-TX/10Base T, half duplex connectivity
- A green "Link" LED. This LED will be on if there is either a 100Base-T or 10Base-T Link.
- A green "Activity" LED. This LED will be on whenever a send or receive packet has occurred.

Communication using the Ethernet Port can be between the MMC Smart Drive Control and a PC, User Interface, or other Ethernet device or network.

Table 4: Pinout for Ethernet Port (C4)

Pin	Description	In/Out
1	Transmit Data + (TD+)	Out
2	Transmit Data - (TD-)	Out
3	Receive Data + (RD+)	In
6	Receive Data - (RD-)	In
4,5,7,8	Termination Resistors (See Note 1, below)	In
Shell	Chassis Ground	In

Note 1: Pins 4, 5, 7, and 8 are tied to termination resistors on the MMC Smart Drive Control. Standard Ethernet cables contain 8 wires. The MMC Smart Drive Control only uses 4 of these wires as shown. Connecting the 4 unused wires to the MMC Smart Drive Control pins 4, 5, 7, and 8, (as will be done in a standard Ethernet cable) reduces noise that can be induced from the unused wires to the Transmit and Receive wires.

Typically, a "straight-through" cable should be used when connecting the MMC Smart Drive Control to another Ethernet device. Refer to Figure 11.4 on page 162 for cables available from G&L Motion Control.

10.5.5 General I/O Port (C5)

The General I/O Port (C5) is a 26-pin male high density "D" connector and includes:

- 8-24 VDC sourcing inputs (Input 1 can trigger an interrupt on the rising or falling edge)
- +24 VDC and 24 V Common
- 8-24 VDC outputs
 - Source only
 - 250 mA output capacity
 - Short circuit protection

Table 5: Pinout for General I/O Port (C5)

Pin	Description	In/Out	Pin	Description	In/Out
1	DCOUT1	Out	16	IO24C	In/Out
2	DCOUT2	Out	17	IO24C	In/Out
3	DCOUT3	Out	18	IO24C	In/Out
4	DCOUT4	Out	19	DCIN1	In
5	DCOUT5	Out	20	DCIN2	In
6	DCOUT6	Out	21	DCIN3	In
7	DCOUT7	Out	22	DCIN4	In
8	DCOUT8	Out	23	DCIN5	In
9	24VDC OUT POWER	In	24	DCIN6	In
10	IO24V	In/Out	25	DCIN7	In
11	IO24V	In/Out	26	DCIN8	In
12	IO24V	In/Out			
13	IO24V	In/Out			
14	IO24C	In/Out			
15	IO24C	In/Out			

NOTES:

- Pin 9 is 24VDC into the MMC Smart Drive Control to power the 8 outputs
- Pins 10-13 are only connected to each other within the MMC Smart Drive Control. If used, tie one pin to 24VDC, and the other to one side of input devices.
- Pins 14-18 are connected together within the MMC Smart Drive Control. Connect pin 14 to 24V common. This provides the return path for the 24VDC inputs. and allows pin 15-18 to be connected to one side of output devices if desired.

There are 8 DC outputs on the General I/O Port (C5). These outputs get their power from Pin 9 of the MMC Smart Drive Control as shown in Figure 3.

Figure 3: General Outputs for General I/O Port (C5) Connected to Loads

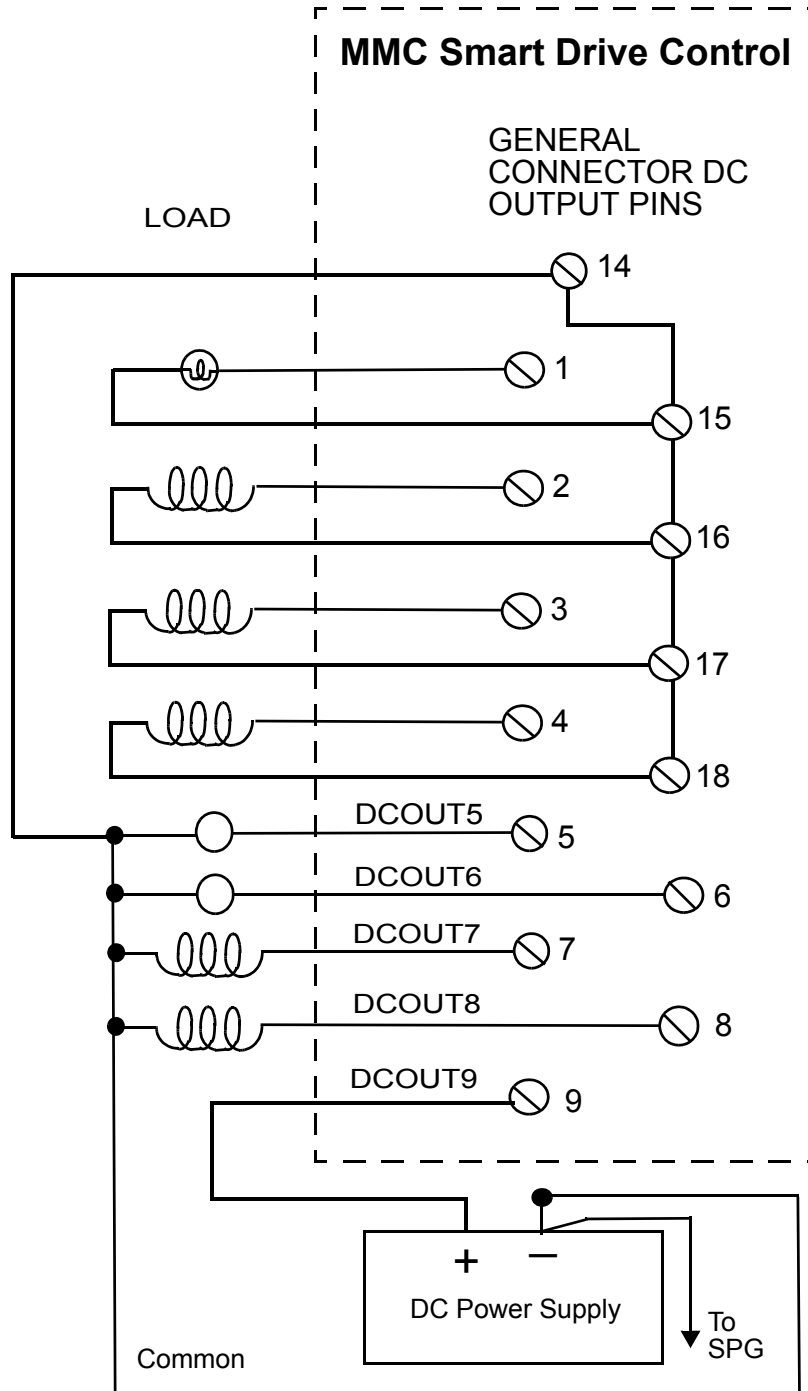

There are 8 general inputs on the General I/O Port (C5). The inputs are configured as sourcing as shown in Figure 4.

Figure 4: Source General Input Configuration for General I/O Port (C5)

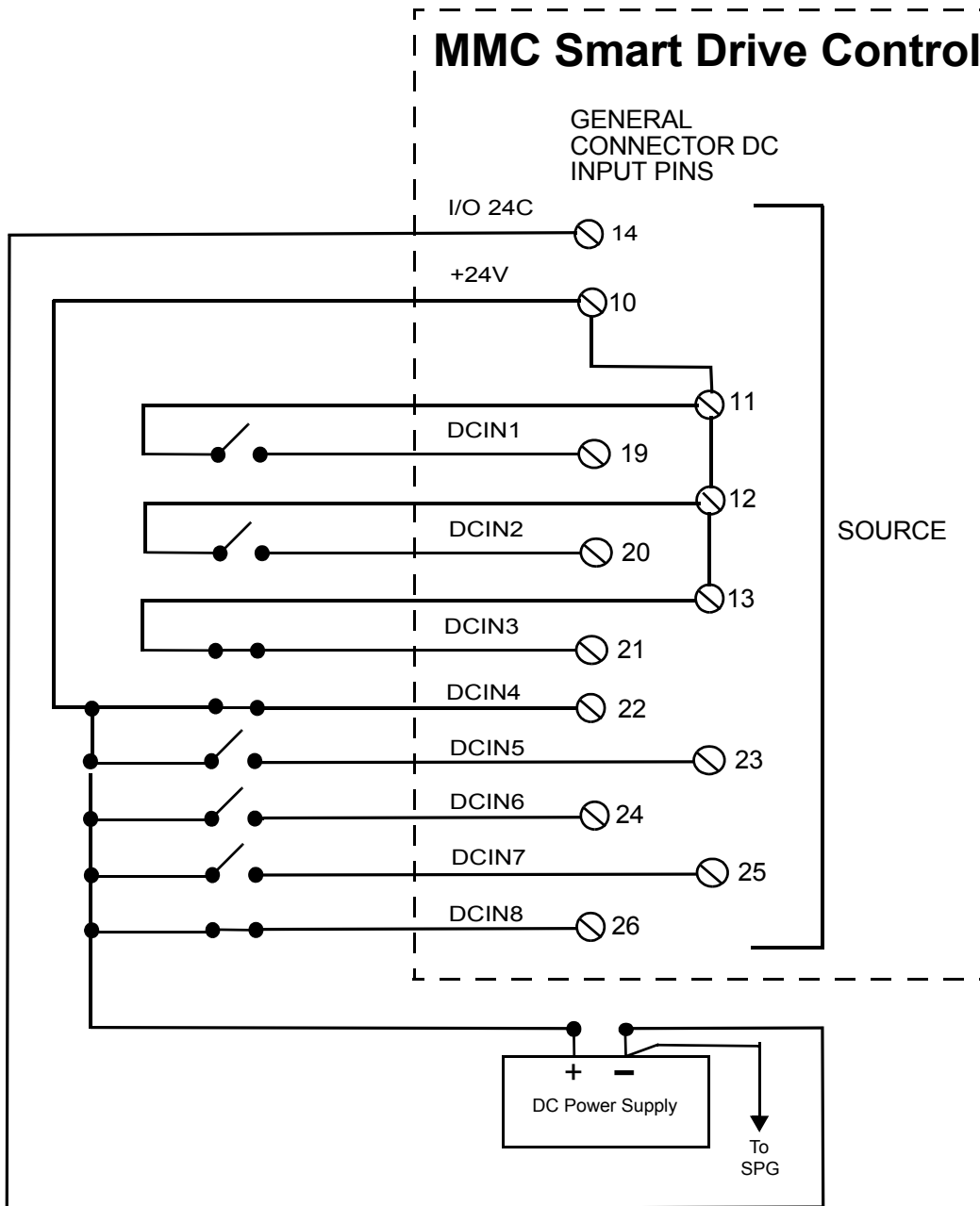

10.6 Specifications

General											
Characteristic		MMC Specifications									
						Number of servo axes available at six update rates*					
Model	Part No.	Speed	App Mem	RAM Mem	User Mem	8 ms	4 ms	2 ms	1 ms	.5 ms	.25 ms
Digital MMC-D1	M.1302 .8230	Std.	384K	256K	64K	1	1	1	1	1	1
Digital MMC-D2	M.1302 .8231	Std.	384K	256K	64K	2	2	2	2	2	1
Digital MMC-D4	M.1302 .8232	Std.	384K	256K	64K	4	4	4	4	2	1
Digital MMC-D16	M.1302 .8233	X1.5	384K	256K	64K	16	16	8-16	4-8	2-4	1-2

* Using features such as servo tasks, S-curve, RATIO_RL, M_LINCIR, M_SCRVLC, PLS, and CAM_OUT places a heavier burden on available CPU time. Consult G&L Motion Control for assistance if you want to exceed the number of axes in this chart.

CPU	32 bit RISC processor with numeric coprocessor
Battery	3V Coin Cell, BR2032 lithium battery
<p>CAUTION for Lithium Batteries Danger of explosion if battery is incorrectly replaced. Replace only with the same or equivalent type recommended by the manufacturer. Dispose of used batteries according to the manufacturer's instructions.</p>	
Flash Disk	2 Megabytes
Memory	1 Megabyte max.
PiCPro Port (to workstation)	RS232 serial port, secured protocol Software selectable baud rate to 115.2K
User Port (to serial interface device)	RS232/RS485 serial port Supports RTS/CTS hardware handshaking Software selectable baud rate to 115.2K
Ethernet Port (to Ethernet Device)	IEEE 802.3/802.3u-100Base-TX/10Base T Half duplex
Input voltage from MMC-SD Drive	20 VDC to 30 VDC

Input power from MMC-SD Drive	250 mA
Time-of-day clock Clock tolerance	Access via PiCPro 10.2 and above or your application program At 25°C (77°F), ±1 second per day Over temperature, voltage and aging variation, +2/-12 seconds per day
General DC Inputs	
Configuration	Sourcing only. Operates with IEC Type 1 inputs (per IEC 1131-2)
Input voltage	Nominal 24 VDC, maximum 30 VDC
Guaranteed on voltage	15 VDC
Guaranteed off voltage	5 VDC
Turn on/off time	1 ms
General DC Outputs	
Number of outputs	8 outputs
Input voltage	Nominal 24 VDC, 30 VDC maximum
Configuration	Eight solid-state switches.
Protection of logic circuits	Optical isolation between the logic and field side, transient suppression on the 24V external supply
Maximum current	.25 A per output
Voltage range	24 VDC nominal, 5 to 30 VDC
Switch characteristics	Solid-state switches
Time delay on for resistive loads	50 µsec max
Time delay off for resistive loads	50 µsec max
Leakage current in off state	0.5 mA max
Switch voltage, maximum ON	1 VDC max
Short circuit protection for each group	15 A (max) pulses for about 130 µsec every 100 msec until short is removed
Scan loss response	Outputs turn off

11 Part Numbers

11.1 Drives

DESCRIPTION	MODEL NUMBER	PART NUMBER
230V MMC Smart Drive		
2.5A Cont. / 7.5A Max./ .5kW	MMC-SD-0.5-230	M.1302.5090
	MMC-SD-0.5-230-D	M.1302.8130
5A Cont. / 15A Max./ 1kW	MMC-SD- 1.0-230	M.1302.5091
	MMC-SD-1.0-230-D	M.1302.8131
10A Cont. / 30A Max / 2kW	MMC-SD-2.0-230	M.1302.5092
	MMC-SD-2.0-230-D	M.1302.8132
460V MMC Smart Drive		
3.0A Cont. / 6.0A Max. / 1.3 kW	MMC-SD-1.3-460	M.1302.5093
	MMC-SD-1.3-460-D	M.1302.8133
5.5A Cont. / 11.0A Max. / 2.4 kW	MMC-SD-2.4-460	M.1302.5094
	MMC-SD-2.4-460-D	M.1302.8134
9.0A Cont. / 18.0A Max. / 4.0 kW	MMC-SD-4.0-460	M.1302.5095
	MMC-SD-4.0-460-D	M.1302.8135
13.5A Cont. / 27.0A Max. / 6.0 kW	MMC-SD-6.0-460	M.1302.5096
	MMC-SD-6.0-460-D	M.1302.8136
18.0A Cont. / 36.0A Max. / 8.0 kW	MMC-SD-8.0-460	M.1302.5097
	MMC-SD-8.0-460-D	M.1302.8137
27.5A Cont. / 55.0A Max. / 12.0 kW	MMC-SD-12.0-460	M.1302.5098
	MMC-SD-12.0-460-D	M.1302.8138
36.5A Cont. / 73.0A Max. / 16.0 kW	MMC-SD-16.0-460	M.1302.5099
	MMC-SD-16.0-460-D	M.1302.8139
55.0A Cont. / 110.0A Max. / 24.0 kW	MMC-SD-24.0-460	M.1302.5100
	MMC-SD-24.0-460-D	M.1302.8140

11.2 Option Modules

11.2.1 Resolver Interface Option Module

Module	Model Number	Part Number
Resolver Interface Option Module		M.1302.4523

11.2.2 MMC Smart Drive Control

MMC Smart Drive Control	Model Number	Part Number
1 Axis Controller	Digital MMC-D1	M.1302.5101
2 Axis Controller	Digital MMC-D2	M.1302.5102
4 Axis Controller	Digital MMC-D4	M.1302.5103
16 Axis Controller	Digital MMC-D16	M.1302.5104

11.3 Direct Connect Cables

11.3.1 Drive Programming Cable

Description	Drive Connector	Part Number
PiCPro Port to PC Connector (Analog)	P1	M.1302.8250
PiCPro Port to PC Connector (Digital)		M.1302.8284

11.3.2 Standalone MMC to MMC Smart Drive I/O Cable

Description	Drive Connector	Part Number
MMC A'n' to MMC Smart Drive I/O 0.5M	IO	M.1302.5990
MMC A'n' to MMC Smart Drive I/O 1.0M		M.1302.5991
MMC A'n' to MMC Smart Drive I/O 1.5M		M.1302.5992
MMC A'n' to MMC Smart Drive I/O 3.0M		M.1302.5993

11.4 Digital Link and Networking Cables

Description	Drive Connector	MMC-SD Control Connector	Part Number
CAT5e Patch Cord 0.3M	IN, OUT	C4	M.1302.8285
CAT5e Patch Cord 0.6M			M.1302.8286
CAT5e Patch Cord 1.0M			M.1302.8287
CAT5e Patch Cord 2.0M			M.1302.8288
CAT5e Patch Cord 3.0M			M.1302.8289
CAT5e Patch Cord 5.0M			M.1302.8300
CAT5e Patch Cord 10M			M.1302.8301
CAT5e Patch Cord 15M			M.1302.8302
CAT5e Patch Cord 30M			M.1302.8303

11.5 Connector Kits

Description	Part Number
CONN-FBK-17POS-16-28AWG	M.1302.0510
CONN-PWR-BRK-8POS-16AWG	M.1302.0479
CONN-PWR-BRK-8POS-12-14AWG	M.1302.1998
CONN-PWR-BRK-8POS-8-10AWG	M.1302.2354
CONN-PWR-FAN-6POS-16AWG	M.1302.6219
CONN-X100-X101	M.1302.7099
CONN-4TERM-MAINS	M.1302.7158
CONN-4TERM-MOTOR	M.1302.7159

11.6 Breakout Boards/Flying Leads Cables and Kits

11.6.1 Mounted Breakout Boards

Description	Drive Connector	Part Number
BKOUT BD, F1/F2 MMC-SD DR MT	F1, F2	M.1302.6970
BKOUT BD, I/O MMC-SD DR MT	IO	M.1302.6971
MMC Block I/O Breakout Board	C1	Contact G&L Motion Control
MMC Block I/O Breakout Board	C3	

11.6.2 Panel Mounted Breakout Boards

Description	Drive Connector	MMC-SD Control Connector	Part Number
BKOUT BD, F1/F2 MMC-SD PNL MT	F1, F2		M.1302.6972
BKOUT BD, I/O MMC-SD PNL MT	IO		M.1302.6973
BKOUT BD, DIG I/O MMC I/O PNL MT		C5	M.1302.8253

11.6.3 Breakout Board Kits

Description	Drive Connector	Part Number
KIT, BKOUT BD, F1/F2 MMC-SD 1.0M	F1, F2	M.1302.7005
KIT, BKOUT BD, F1/F2 MMC-SD 3.0M		M.1302.7006
KIT, BKOUT BD, F1/F2 MMC-SD 9.0M		M.1302.7007
KIT, BKOUT BD, F1/F2 MMC-SD 15.0M		M.1302.7008
KIT, BKOUT BD, I/O MMC-SD 1.0M	IO	M.1302.7009
KIT, BKOUT BD, I/O MMC-SD 3.0M		M.1302.7030
KIT, BKOUT BD, I/O MMC-SD 9.0M		M.1302.7031

11.6.4 Breakout Board Cables

Description	Drive Connector	MMC-SD Control Connector	Part Number
CABLE, BKOUT BD, F1/F2 MMC-SD 1.0M	F1, F2		M.1302.6976
CABLE, BKOUT BD, F1/F2 MMC-SD 3.0M			M.1302.6977
CABLE, BKOUT BD, F1/F2 MMC-SD 9.0M			M.1302.6979
CABLE, BKOUT BD, F1/F2 MMC-SD 15.0M			M.1302.6980
CABLE, BKOUT BD, I/O MMC-SD 1.0M	IO		M.1302.6982
CABLE, BKOUT BD, I/O MMC-SD 3.0M			M.1302.6984
CABLE, BKOUT BD, I/O MMC-SD 9.0M			M.1302.6985
CABLE, BKOUT BD, DIG-MMC I/O 1.0M		C5	M.1302.8254
CABLE, BKOUT BD, DIG-MMC I/O 3.0M			M.1302.8255
CABLE, BKOUT BD, DIG-MMC I/O 9.0M			M.1302.8256
CABLE, MMC User Serial Port to Breakout Board, 1 Foot		C3	Contact G&L Motion Control
CABLE, MMC User Serial Port to Breakout Board, 2 Foot			
CABLE, MMC User Serial Port to Breakout Board, 3 Foot			
CABLE, MMC Block I/O Port to Breakout Board, 1 Foot	C1		
CABLE, MMC Block I/O Port to Breakout Board, 2 Foot			
CABLE, MMC Block I/O Port to Breakout Board, 3 Foot			

11.6.5 User I/O Flying Lead Cables

Description	Drive Connector	MMC-SD Control Connector	Part Number
CABLE, USER I/O, MMC-SD 1.0M	IO		M.1302.7032
CABLE, USER I/O, MMC-SD 3.0M			M.1302.7034
CABLE, USER I/O MMC-SD 9.0M			M.1302.7035
CABLE, USER I/O, MMC-SD 15.0M			M.1302.7036
CABLE, USER I/O, MMC-SD 30.0M			M.1302.7037
CABLE, DIG-MMC I/O, 1.0M		C5	M.1302.8257
CABLE, DIG-MMC I/O, 3.0M			M.1302.8258
CABLE, DIG-MMC I/O, 9.0M			M.1302.8259
CABLE, DIG-MMC I/O, 15.0M			M.1302.8290
CABLE, DIG-MMC I/O, 30.0M			M.1302.8291
CABLE, MMC User Serial Port to Flying Lead		C3	Contact G&L Motion Control
CABLE, MMC Block I/O Port to Flying Lead		C1	

11.7 Motor Cables (LSM/MSM Motors)

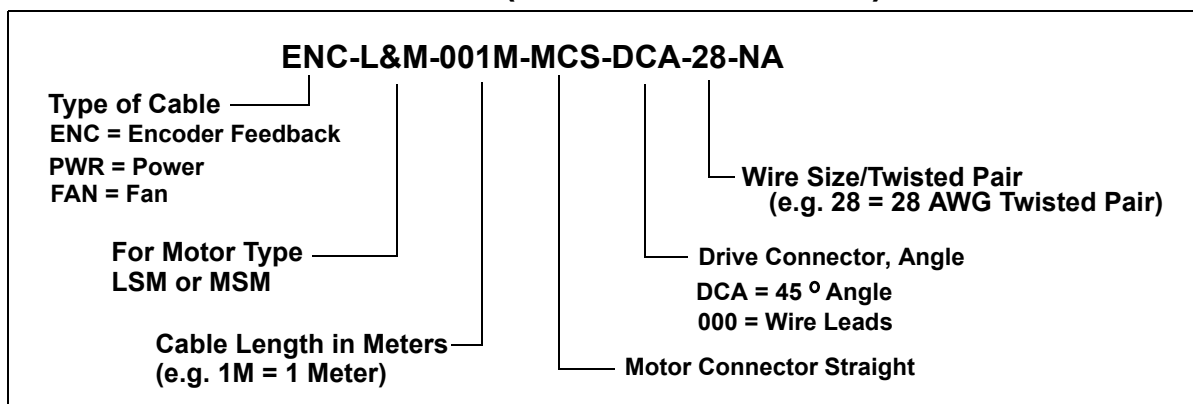

11.7.1 Feedback Cables (LSM/MSM Motors)

Feedback Cable	Part Number
Static Type	
ENC-L&M-001M-MCS-DCA-28-NA	M.1302.0944
ENC-L&M-003M-MCS-DCA-28-NA	M.1302.0945
ENC-L&M-009M-MCS-DCA-28-NA	M.1302.0946
ENC-L&M-015M-MCS-DCA-28-NA	M.1302.0947
ENC-L&M-030M-MCS-DCA-28-NA	M.1302.0948
Flexing Type	
ENC-L&M-001M-MCS-DCA-28-AA	M.1302.5834
ENC-L&M-003M-MCS-DCA-28-AA	M.1302.5835
ENC-L&M-009M-MCS-DCA-28-AA	M.1302.5836
ENC-L&M-015M-MCS-DCA-28-AA	M.1302.5837
ENC-L&M-030M-MCS-DCA-28-NA	M.1302.5838

11.7.2 Power Cables for Blower Fan (LSM/MSM Motors)

Power Cable	Part Number
FAN-L&M-001M-MCS-000-16	M.1302.6310
FAN-L&M-003M-MCS-000-16	M.1302.6311
FAN-L&M-009M-MCS-000-16	M.1302.6312
FAN-L&M-015M-MCS-000-16	M.1302.6313
FAN-L&M-030M-MCS-000-16	M.1302.6314

11.7.3 Motor Power Cables (LSM/MSM Motors)

Power Cable (Flexing Type)	Part Number
PWR-L&M-001M-MCS-000-16-6H	M.1302.1114
PWR-L&M-003M-MCS-000-16-6H	M.1302.1115
PWR-L&M-009M-MCS-000-16-6H	M.1302.1116
PWR-L&M-015M-MCS-000-16-6H	M.1302.1117
PWR-L&M-030M-MCS-000-16-6H	M.1302.1118
PWR-L&M-001M-MCS-000-14-6H	M.1302.1119
PWR-L&M-003M-MCS-000-14-6H	M.1302.1130
PWR-L&M-009M-MCS-000-14-6H	M.1302.1131
PWR-L&M-015M-MCS-000-14-6H	M.1302.1132
PWR-L&M-030M-MCS-000-14-6H	M.1302.1133
PWR-L&M-001M-MCS-000-12-6H	M.1302.1134
PWR-L&M-003M-MCS-000-12-6H	M.1302.1135
PWR-L&M-009M-MCS-000-12-6H	M.1302.1136
PWR-L&M-015M-MCS-000-12-6H	M.1302.1137
PWR-L&M-030M-MCS-000-12-6H	M.1302.1139
PWR-L&M-001M-MCS-000-10-6H	M.1302.1140
PWR-L&M-003M-MCS-000-10-6H	M.1302.1142
PWR-L&M-009M-MCS-000-10-6H	M.1302.1143
PWR-L&M-015M-MCS-000-10-6H	M.1302.1144
PWR-L&M-030M-MCS-000-10-6H	M.1302.1145
PWR-L&M-001M-MCS-000-08-6H	M.1302.1146
PWR-L&M-003M-MCS-000-08-6H	M.1302.1147
PWR-L&M-009M-MCS-000-08-6H	M.1302.1148
PWR-L&M-015M-MCS-000-08-6H	M.1302.1149
PWR-L&M-030M-MCS-000-08-6H	M.1302.1150

11.8 Optional External Devices

11.8.1 AC Line Filters

For Drive Model	AC Line Filter Description	Line Filter Part No.
MMC-SD-0.5-230 MMC-SD-1.0-230	6A, 250V, Single phase	M.1015.6922
MMC-SD-2.0-230	10A, 250V, Single phase,	M.1015.6917
MMC-SD-1.3-460 MMC-SD-2.4-460	7A, 480V, Three phase	M.1302.5241
MMC-SD- 4.0-460 MMC-SD-6.0-460 MMC-SD- 8.0-460	16A, 480V, Three phase	M.1302.5244
MMC-SD-12.0-460 MMC-SD-16.0-460	30A, 480V, Three phase	M.1302.5245
MMC-SD-24.0-460	42A, 480V, Three phase	M.1302.5246
To be determined	56A, 480V, Three phase	M.1302.5247
To be determined	75A, 480V, Three phase	M.1302.5248

11.8.2 AC Line Reactors

Drive Model	Required Line Reactor (Amps)	Power Loss (Watts)	Inductance (mH)	Weight (Pounds)	Part Number
MMC-SD-12.0-460*	25	52	1.2	14	M.1302.7373
MMC-SD-16.0-460*	35	54	0.8	16	M.1302.7374
MMC-SD-24.0-460*	45	62	0.7	28	M.1302.7375

*Add -D suffix for digital drive.

11.8.3 External Shunt Resistor Kits

For Drive	Shunt Resistor Module	Part Number
MMC-SD-0.5-230 MMC-SD-1.0-230 MMC-SD-2.0-230	100Ω, 300W, 600V, Dynamic	M.1015.7046
MMC-SD-1.3-460 MMC-SD-2.4-460	130Ω, 450W Cont. Power, 5.4kW Peak Power, 820V, 240 sec. Time Constant, 121 mm x 93 mm x 605 mm	M.1302.7048
MMC-SD-4.0-460	95Ω, 700W Cont. Power, 8kW Peak Power, 820V, 250 sec. Time Constant, 121 mm x 93 mm x 705 mm	M.1302.7049
MMC-SD-6.0-460 MMC-SD-8.0-460	50Ω, 1400W Cont. Power, 17kW Peak Power, 850V, 250 sec. Time Constant, 130 mm x 182 mm x 710 mm	M.1302.7060
MMC-SD-12.0-460 MMC-SD-16.0-460	25Ω, 2800 W Cont. Power, 32kW Peak Power, 850V, 60 sec. Time Constant, 71 mm x 430 mm x 550 mm	M.1302.7061
MMC-SD-24.0-460	18Ω, 3900W Cont. Power, 70kW Peak Power, 850V, 70 sec. Time Constant, 180 mm x 445 mm x 490 mm	M.1302.7063

11.9 Software

Description	Part Number
PiCPro Professional Edition	M.1300.7213
PiCPro MMC Limited Edition	M.1300.7214
PiCPro Monitor Edition	M.1300.7215

12 Declarations of Conformity

EC DECLARATION OF CONFORMITY

The undersigned, representing the supplier

**G & L Motion Control Inc.
672 South Military Road
Fond du Lac, Wisconsin 54936-1960**

herewith declares that all **three-phase current synchronous motors, type LSM** are in conformity with the provisions of the following EC Directive when installed in accordance with the installation instructions contained in the product documentation:

Low Voltage Directive 73/23 EWG

Conformity of the specified product with the guidelines of this directive will be proved by the total compliance with the following harmonic European standards:

*EN 60034-1: September 2000 Rotating Electrical Machines
+A11 May 2002
EN 60034-5: December 2001
EN 60034-9: June 1998*

Year of Marking: 2002

Signature	<i>Robert J. Kollmeyer</i>
Full Name	Robert J. Kollmeyer
Position	Director of Engineering
Place	G & L Motion Control Inc.
Date	<i>05-APR-05</i>

EC DECLARATION OF CONFORMITY

The undersigned, representing the supplier

G & L Motion Control Inc.
672 South Military Road
Fond du Lac, Wisconsin 54936-1960

herewith declares that all **three-phase current synchronous motors, type MSM** are in conformity with the provisions of the following EC Directive when installed in accordance with the installation instructions contained in the product documentation:

Low Voltage Directive 73/23 EWG

Conformity of the specified product with the guidelines of this directive will be proved by the total compliance with the following harmonic European standards:

EN 60034-1: November 1995 Rotating Electrical Machines
EN 60034-5: April 1998
EN 60034-9: May 1996

Year of Marking: 1999

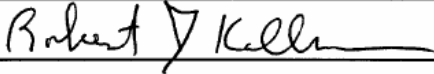
Signature	
Full Name	Robert J. Kollmeyer
Position	Director of Engineering
Place	G & L Motion Control Inc.
Date	05 - APR - 05

Declarations of Conformity

The undersigned, representing the supplier

**G & L Motion Control Inc.
672 South Military Road
Fond du Lac, Wisconsin 54936-1960**

herewith declares that all **PiC900™/PiC90™/PiC9™/MMC and Block I/O modules**, labeled with the CE mark, are in conformity with the provisions of the following EC Directives when installed in accordance with the installation instructions contained in the product documentation:

*Low Voltage Directive 73/23/EEC as amended by 93/68/EEC
EMC Directive 89/336/EEC as amended by 92/31/EEC and 93/68/EEC*

Conformity of the specified product is based upon application of the following standards and/or technical specifications referenced below:

<i>EN 50081-2:1993</i>	<i>EMC Generic Industrial Emissions</i>
<i>EN 50082-2:1995</i>	<i>EMC Generic Industrial Immunity</i>
<i>EN 61131-2:1994/A11:1996</i>	<i>Low voltage requirements for programmable controllers</i>
<i>EN61326:1997</i>	<i>Electrical Equipment for measurement, control and Laboratory use – EMC requirements</i>

Year of Marking: 2002

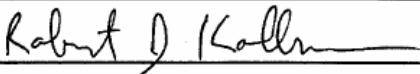
<i>Signature</i>	
<i>Full Name</i>	Robert J. Kollmeyer
<i>Position</i>	Director of Engineering
<i>Place</i>	G & L Motion Control Inc.
<i>Date</i>	05-APR-05

EC DECLARATION OF CONFORMITY

The undersigned, representing the supplier

G & L Motion Control Inc.
672 South Military Road
Fond du Lac, Wisconsin 54936-1960

herewith declares that all **servo drives and accessories** (see attached list of catalogue numbers) are in conformity with the provisions of the following EC Directive(s) when installed in accordance with the installation instructions contained in the product documentation:

Low Voltage Directive as amended by 93/68/EEC

EMC Directive as amended by 92/31/EEC and 93/68/EEC

and that the standards and/or technical specifications referenced below have been applied:

EN 60034-1:1998 + A1:1998 and A2:1999 *Rotating Electrical Machines*
Part 1: Rating and Performance

EN 60204-1:1997 *Safety of machinery – Electrical equipment of machines*
Part 1: Specifications for general requirements

EN 61800-3:1996 *Adjustable Speed Electrical Power Drive Systems – EMC*
Product Standard Including Specific Test Methods

Year of Marking: 2002

<i>Signature</i>	<i>Robert J. Kollmeyer</i>
<i>Full Name</i>	Robert J. Kollmeyer
<i>Position</i>	Director of Engineering
<i>Place</i>	G & L Motion Control Inc.
<i>Date</i>	<i>05 - APR - 05</i>

EC DECLARATION OF CONFORMITY

The undersigned, representing the supplier

**G & L Motion Control Inc.
672 South Military Road
Fond du Lac, Wisconsin 54936-1960**

herewith declares that all **MMC Smart Drives (MMC-SD-XXX-230-XXX, MMC-SD-XXX-460-XXX) and accessories** are in conformity with the provisions of the following EC Directive(s) when installed in accordance with the installation instructions contained in the product documentation:

73/23/EEC
89/336/EEC

*Low Voltage Directive as amended by 93/68/EEC
EMC Directive as amended by 92/31/EEC and 93/68/EEC*

and that the standards and/or technical specifications referenced below have been applied:

EN 50178:1998
EN 61800-3:1996
/A11:2000

*Electronic equipment for use in power installations
Adjustable speed electrical power drive systems – EMC
product standard including specific test methods*

Year of Marking: 2003

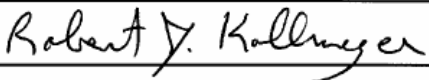
Signature	
Full Name	Robert J. Kollmeyer
Position	Director of Engineering
Place	G & L Motion Control Inc.
Date	05-APR-05

Appendix A - 460V MMC Smart Drive DC Bus Sharing

A.1 Introduction

This section discusses DC bus sharing among 2 or more 460V Smart Drives.

DC bus sharing accomplishes 4 things:

- It pools the capacitance of all of the drives.
- It lowers electricity cost.
- It allows multiple drives to share one shunt resistor.
- It allows the shunt energy to be shared among multiple shunt resistors.

Pooling the capacitance increases the Joule energy absorption capability to the sum of the drives connected (See Table A-2). This lowers energy cost slightly because energy that can be absorbed is not wasted in the shunt resistors. In some applications, this can eliminate the need for a shunt resistor altogether.

Many applications will have one drive motoring while the other is regenerating. This energy is transferred from one drive to the other through the DC bus rather than being dissipated in a shunt. This saves energy cost.

If it is desired to share one shunt resistor instead of using one per drive, the energy flows through the DC bus to the drive controlling the shunt resistor. Its internal circuitry will turn the shunt on when the bus voltage reaches an upper limit.

If it is desired to distribute the shunt load among multiple drives, each having a smaller resistor, then **it is important to interconnect the "Shunt On" signals for all drives sharing the DC bus**. This ensures that all of the shunt resistors will properly share the load. If this connection is not made, it is likely that only one shunt resistor will dissipate all of the shunt power, overheating it.

A.2 DC Bus Sharing with AC Power to All Drives

When sharing DC power among several drives with AC power supplying all of the drives (See Figure A-1), all drives must be the same size (for example, all drives must be MMC-SD-4.0-460). When two drives are connected to a shared DC bus in this manner, the combined energy absorption of all drives is available.

3% line reactors are required for all sizes using this configuration to ensure rectifier balance. However, shunt resistors are optional (see below). Refer to Chapter 4 in this manual for information related to fusing, line reactors and shunts. Refer to Chapter 6 for connector information.

When more than one shunt is used with the MMC Smart Drives, it is important to tie the "Shunt On" circuits together so that all shunts get turned on at the same time. For example, in Figure A-1, if the shunt connected to Drive 1 turns on, the

"Shunt On" signal will turn on the shunt for Drive 2. The second shunt resistor is optional as long as the "Shunt On" signal is connected as shown. The "Shunt On" signal acts as both an input and an output for each Drive.

Figure A-1: DC Bus Sharing with AC Input Power to All Drives

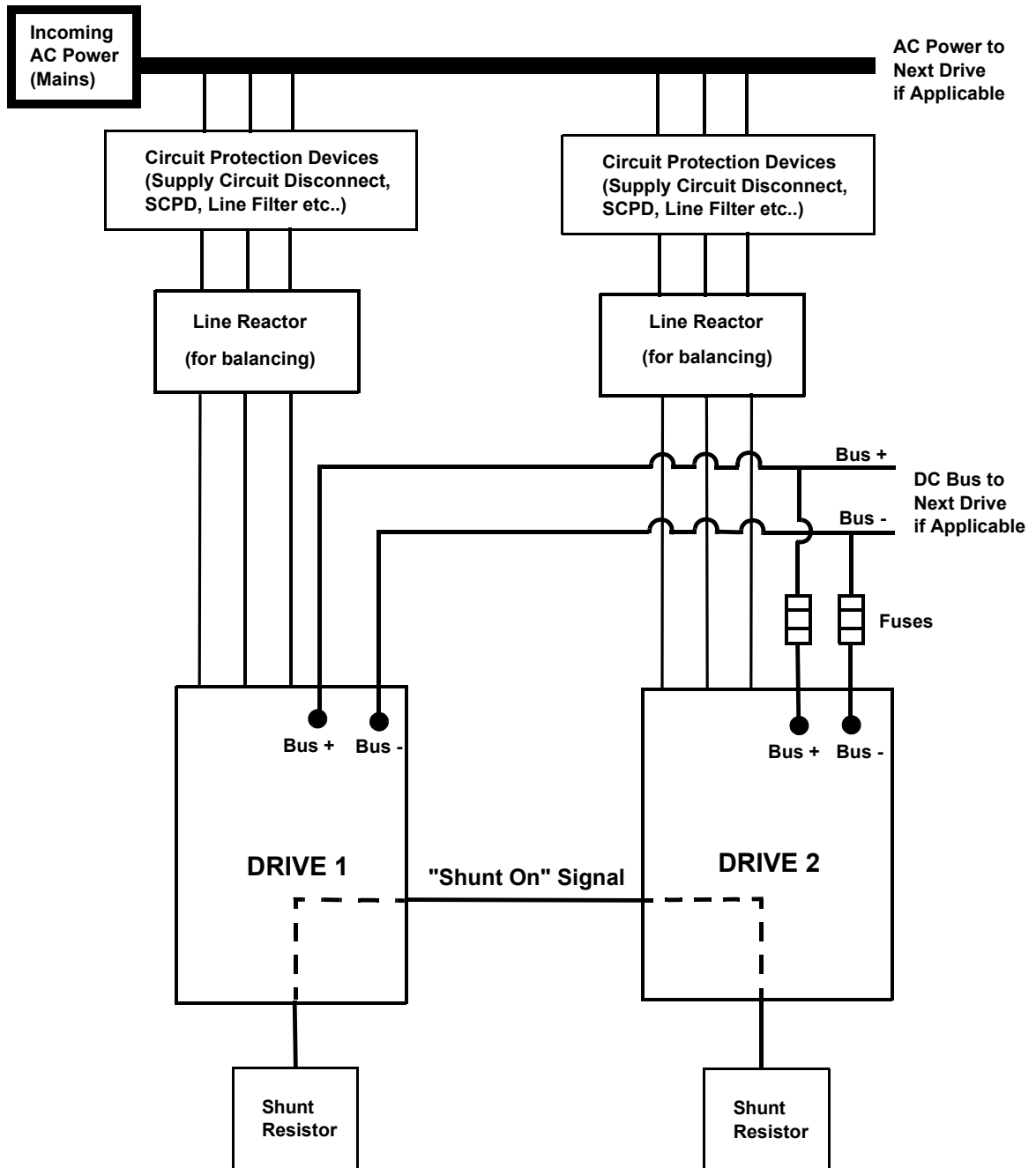

A.3 DC Bus Sharing with AC Power to One Drive

When sharing DC power among several drives with AC power supplying just one of the drives (See Figure A-2), all drives need not be the same size (for example, one drive may be a MMC-SD-8.0-460, and another drive may be a MMC-SD-1.3-460). When two or more drives are connected to a shared DC bus in this manner, there are two limits that must be considered:

- The drives not powered by AC must not consume more power than the "Bus power available for linking to other drives" as listed in Table A-1.
- The total power consumed by all drives cannot exceed the greater of "Bus power available for linking to other drives" and the kW rating of the AC powered drive as listed in Table A-1.

For example, assume that the AC powered drive is a MMC-SD-24.0-460 and consumes 14kW, and supplies DC power to two more drives that consume 4kW each (8kW total). From Table A-1, the total DC power available to the non-AC powered drives is 10kW, meeting the first criteria. The total power consumed is 22kW, and since the AC powered drive is a 24kW drive, meets the second criteria.

The continuous current available from the drive would be reduced by the same percentage as the kW. In the example given, the available kW was reduced from 24 to 16kW. Therefore $16/24 = 67\%$. The drive's continuous current is reduced by 1/3 from 45 Amps to 30 Amps.

If peak current is to be used at the same time on more than one drive, the total peak current used by all drives must not exceed that of the main drive. If both the main and auxiliary drives will accelerate at the same time, the peak current used by auxiliary drives is subtracted from the available peak current of the main drive. Connection of a shunt to the main drive is optional depending on the results found in sizing the system. The system will have the combined DC Bus capacitance of all drives connected.

Table A-2 on page 5 shows the MMC Smart Drive bus capacitance and energy absorption capability.

Table A-1: kW Ratings for Powered Drive

Drive MMC-SD-xx-460	1.3kW	2.4kW	4.0kW	6.0kW	8.0kW	12.0kW	16.0kW	24.0kW
Bus power available for linking to other drives	2.0kW	2.0 kW	5.0kW	5.0kW	5.0kW	10.0kW	10.0kW	10.0kW
Continuous Current (Amps)	3	5.5	9	13.5	18	27.5	36.5	55
Peak Current (Amps)	6	11	18	27	36	55	73	110

Figure A-2: Two or more drives with AC input power to one drive

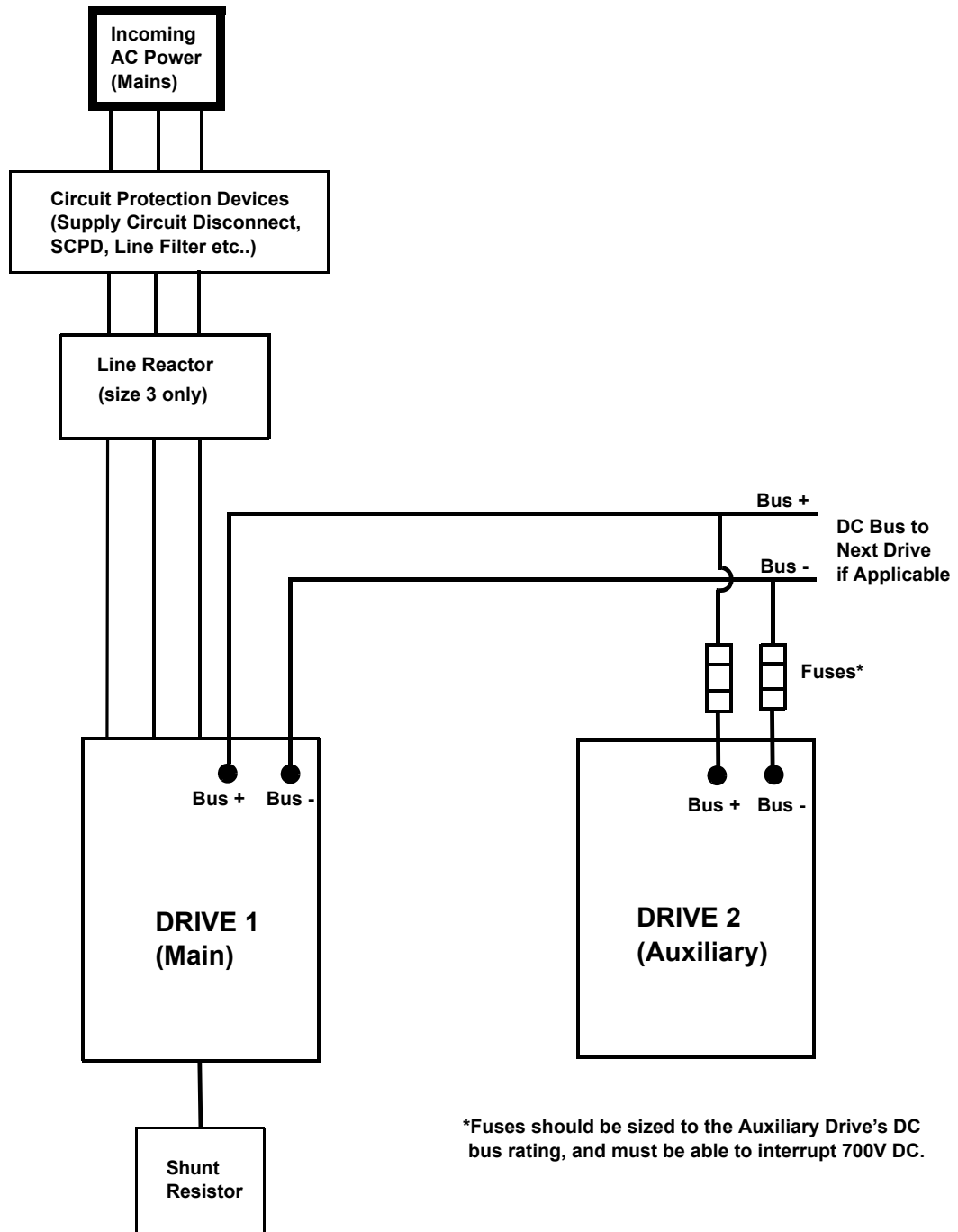

Table A-2: Drive Bus Capacitance and Energy Absorption Capability

Drive*	MMC Smart Drive Bus Capacitance (μ Farad)	Energy Absorption at 230V Line Input and 230V Motor (Joules)	Energy Absorption at 230V Line Input and 460V Motor (Joules)	Energy Absorption at 460V Line Input and 460V Motor (Joules)
460V Size 1				
MMC-SD-1.3-460	110	3	28	10
MMC-SD-2.4-460	240	7	60	22
460V Size 2				
MMC-SD-4.0-460	470	13	118	44
MMC-SD-6.0-460	470	13	118	44
MMC-SD-8.0-460	705	19	177	66
460V Size 3				
MMC-SD-12.0-460	820	22	206	76
MMC-SD-16.0-460	1230	33	309	114
MMC-SD-24.0-460	1640	45	412	152
230 V				
MMC-SD-0.5-460	1410	38		
MMC-SD-1.0-460	1880	51		
MMC-SD-2.0-460	1880	51		

* add suffix (-D) to model number for Digital Drive

INDEX

A

Altitude 75, 101
application
 wiring 29, 146

B

battery
 disposal 159
 type 159
block I/O
 port
 pinout 153
bonding
 mounting 22

C

cables
 pin assignments
 HSM and FSM motors 123
 I/O 116
 LSM and MSM motors 117
 NSM motors 121
 XSM motors 119
 YSM motors 125

CE

filter requirements 27

conformity

 european directives 19
 UL and cUL standards 19

Conformity, Declarations of 170

connections

 general outputs 157
 general purpose inputs 158
 MMC CPU module 152

connector

 block I/O 153
 ethernet 154
 general I/O 155
 user port 153

connectors

 230V 24VDC IN/Brake 73
 230V F1 feedback 65
 230V F2 feedback 68
 230V motor 74

 size 1 460V drive 85
 size 2 460V drive 90
 size 3 460V drive 95
contents of the manual 9
control cabinet
 requirements 24

D

device protection 40
diagnostic
 error codes 132
 LED 150
 run-time 151
 troubleshooting 150

Diagnostics 150

diagnostics

 power on 130
 run-time 131
 runtime 131

dimensions

 230V drive 80
 460V drive 110
 cabinet clearance 20
 line filters 57
 motor cable 36
 shunts 49

distribution

 power 32

download hex 148

E

electrical service & maintenance safety 15

EMI (ElectroMagnetic Interference)

 bonding 22

environment requirements

 system 39

error codes

 diagnostic 132

ethernet

 port
 pinout 154

F

faults

 diagnostic 132

features of the MMC Smart Drive 8

filter, AC power 27

flash memory 159

fuse sizing 39

fuses

NFPA 79 Table 7.2.10.1 40

NFPA 79 Table 7.2.10.4 40

G

general I/O

port pinout 155

general inputs

sinking/sourcing 158

general outputs

connections 157

general purpose inputs

connections 158

grounding

CE single phase 230V drive system 27

multiple drives 29

protective earth 12

system 25

H

handling the MMC Smart Drive 18

heat

controlling 21

hex

download 148

Humidity 75, 101

I

inspection

safety 14

installation 19

installing 18

isolation transformers

230V formula 46

460V formula 46

L

LEDs

230V single phase drive 59

460V analog 3-Phase drive 84

diagnostic 150

error codes 132

power 150

scan 150

line filters

block diagram for 3-phase 53

CE compliance 53

connection diagram for 3-phase 54

part numbers 55

technical data

230V 55

460V 56

line reactors 168

M

maintenance 130

manual cleaning procedure 17

MMC

connecting to an application 148

CPU

module connections 152

overview 142

ports 143

power 33

Servo Control Unit 143

specifications 159

mounting 24

bonding 22

N

noise

see bonding 22

O

operation

safety 14

startup 148

overview

MMC 142

P

part numbers

breakout boards, cables and kits 163

connector kits 162

drive connect cables 161

drives 160

LSM and MSM feedback cables 166

optional external devices 168

PiCPro

port pinout 152

pinout

- block I/O port 153
- ethernet port 154
- general I/O port 155
- PiCPro port 152
- user port 153
- power
 - AC input requirements 39
 - distribution in MMC 32
 - LED 150
- power requirements
 - system 39
- procedure
 - manual cleaning 17
- protective earth
 - grounding 12

R

- Requirements
 - Transformer 39
 - Wire Size 39
- resolver
 - installing 139, 140
- resolver module
 - installing 139
 - theory of operation 139
- run-time diagnostics 151

S

- safety
 - after shutdown 14
 - cleaning 17
 - electrical service & maintenance 15
 - inspection 14
 - operating safely 14
 - operation 14
 - signs 12
 - system 11
 - warning labels 13
- scan
 - LED 150
- shields 30
- Shock 75, 101
- short circuit protection 41
- shunts
 - choosing 47

- dimensions 49
- signs
 - safety 12
- single point ground (SPG)
 - checklist 26
- software
 - required 9
- specifications
 - 230V MMC Smart Drive 75
 - 460V analog drive 101
 - Altitude 75, 101
 - Humidity 75, 101
 - MMC 159
 - optional resolver module 141
 - Shock 75, 101
 - Storage Temperature 75, 101
 - Vibration 75, 101
- storage
 - before installation 18
 - Temperature 75, 101
- storing the drive 18
- switch
 - main disconnect
 - wiring modules 149
- system
 - environment requirements 39
 - power requirements 39
- system mounting requirements
 - fuse sizing 39
 - ventilation 19

T

- technical support contacts 10
- Transformer
 - Size 39
- troubleshooting
 - general 132
- troubleshooting 149
 - fault error codes 133
 - hardware wiring 131

U

- Unpacking 18
- user port
 - pinout 153

V

ventilation 19
Vibration 75, 101

W

warning label
 danger, warning, caution 13
 hazard 13
Wire Size 39
wiring
 application 29, 146

connecting shunt modules 127
connections for 3-phase line filter 54
connectors on 230V drive 60
EMC compliant 29, 146
interface cables 35
preparing motor connection wires 36
routing high/low voltage cables 35
terminating 230V motor power cable 37
terminating 460V power cable 38
user I/O connector 72