

KOLLMORGEN

Motion Technologies Group

TYPE	MODEL NUMBER
KXA-48-8-16/AUX	00-88060-003
KXA-48-8-16/PS/AUX	00-88060-004

*PWM SERVO AMPLIFIER
KXA SERIES*

INSTALLATION AND SETUP MANUAL

M93108 - Issue 1

© Copyright 1994, Industrial Drives, A Kollmorgen Division. All rights reserved.

Printed in the United States of America.

NOTICE:

Not for use or disclosure outside of PMI Motion Technologies except under written agreement.

All rights reserved. No part of this books shall be reproduced, stored in a retrieval system, or transmitted by any means, electronic, mechanical, photocopying, recording, or otherwise without the written permission from the publisher. While every precaution has been taken in the preparation of the book, the publisher assumes no responsibility for errors or omissions. Neither is any liability assumed for damages resulting from the use of the information contained herein.

This document is proprietary information of PMI Motion Technologies, A Kollmorgen Division, furnished for customer use ONLY. No other uses are authorized without written permission of PMI Motion Technologies.

Information in this document is subject to change without notice and does not represent a commitment on the part of PMI Motion Technologies or the Kollmorgen Corporation. Therefore, information contained in this manual may be updated from time-to-time due to product improvements, etc., and may not conform in every respect to former issues.



Dangerous voltages, currents, temperatures, and energy levels exist in this product and in the associated servo motor(s). Extreme caution should be exercised in the application of this equipment. Only qualified individuals should attempt to install, set-up, and operate this equipment. Ensure that the motor, drive, and the end-user assembly are all properly grounded per NEC requirements.

KOLLMORGEN
Motion Technologies Group

PMI Motion Technologies
49 Mall Drive
Commack, NY 11725
U.S.A.
FAX: (516) 864-4549

THANK YOU!

KOLLMORGEN

Motion Technologies Group

Thank you and congratulations for choosing Kollmorgen servo products for your motion control requirements. We seek to provide our customers with quality products, excellent support and outstanding value. In an effort to provide you with dependable and useful documentation, we offer you an opportunity to suggest improvements to this manual. Your feed back is very important to us. Please send your comments to:

PMI Motion Technologies

49 Mall Drive
Commack, NY 11725
U.S.A.
FAX: (516) 864-4549

Name: _____ Title: _____

Company: _____

Street Address: _____

City: _____ State/Country: _____ Zip: _____

Telephone: _____ Fax: _____

Product: _____

1. Manual Part Number (as appears on the Front Cover): _____

2. Manual Description or Name: _____

3. Page and enhancement idea or correction:

4. Any comments you wish to add: _____

5. Any additional information you feel would make the manual more user friendly.

Thank you for taking the time to support our product and improve it for the next user.

TABLE OF CONTENTS

1. Introduction	1	3. Installation	9
1.1. Features	1	3.1. Mounting Instructions	9
1.2. Specifications.....	3	3.2. Wiring Instructions	9
2. Connections, Controls, and Indicators.....	4	3.3. Power Wiring	10
2.1. Terminal Connections.....	4	3.4. Control Signal Wiring	13
2.2. Controls.....	7	4. Setup Instructions.....	14
2.2.1. Adjustment Potentiometers.....	7	4.1. Setting Current.....	14
2.2.2. Selector Switches	7	4.2. Torque Mode.....	17
2.3. Indicators.....	8	4.3. Velocity Mode with Tachometer	18
2.3.1. LED Indicators	8	4.4. Velocity Mode with EMF Sensing	21
2.3.2. Test Points	9	5. Troubleshooting	22
2.3.3. Fuse	9	5.1. Indicators	22
		5.2. Quick-Check Procedure	22

PWM SERVO AMPLIFIER

1. INTRODUCTION

The KXA is a pulse-width modulated servo amplifier specifically designed to be a high performance drive for a wide range of dc servo motors. It is a compact, self-contained unit with modular design. It is offered in 2 configurations. The main amplifier module includes an inductor. As a standard feature is an auxiliary power output supply on this main module that is useful for powering other external devices. The main module can be operated from a DC supply or battery. A power input supply module can be added to make the KXA a stand-alone amplifier which then requires only the addition of a power transformer.

This unit features extensive fault protection which guards against short circuits, excess current and power supply failure. Motor protection is accomplished through the use of electronic current limiting, which is fully adjustable. Models with power input supply option feature a shunt regulator to protect against excessive regeneration from high speed and high inertia reversals. Control circuitry for this clamp is provided in the main amplifier module.

The KXA amplifier may be operated in both velocity loop and torque modes, with or without a tachometer. Mode selection is by means of selectors on the circuit board.

The switching frequency in the KXA family is 40 kHz, which provides inaudible operation, and very

high bandwidth in the current loop, capable of meeting the most demanding servo applications.

Hook-up and operation is accomplished by carrying out the following steps:

1. Connect AC or DC power wiring to the amplifier.
2. Connect the motor the motor wiring.
3. Connect command and feedback signal wiring.
4. Select mode of operation.
5. Apply power to the amplifier.
6. Set amplifier controls to match application requirements.

1.1. Features

MODULAR DESIGN

State-of-the-art MOSFETS. Auxiliary power output supply. Separate module power input supply including shunt regulator can be added on. Removable connectors for ease of wiring up to and amplifier replacement.

FOUR-QUADRANT PWM OPERATION

Pulse-width modulation provides bi-directional motor operation.

40 KHZ SWITCHING FREQUENCY

High frequency switching for inaudible operation.

EXTENSIVE FAULT PROTECTION

Includes protection against:

- Short circuits
- Current limit failure
- Power supply failure
- Excessive temperature

VELOCITY OR TORQUE MODE OPERATION

Selectable by a dip switch.

TACHOMETER OR EMF SENSING FEEDBACK MODES

Selectable by a dip switch.

ADDITIONAL SIGNAL INPUT

A second input.

ADDITIONAL CONTROL INPUTS

- CW and CCW disable inputs
- Run enable inputs

ADJUSTABLE COMPENSATION

Adjustable breakpoint laglead network simplifies servo system stabilization.

ADJUSTABLE CURRENT LIMITING

Full range current adjustment gives maximum flexibility in matching the amplifier to the application.

1.2. Specifications

Table 1. Input Power Requirements

Input Voltage to Amplifier Module	16 to 48V DC
Nominal input voltage for battery operation	24 or 48V DC
Input Voltage to Power Input Supply Module	12 to 36 vac 1ph 50/400 Hz

Table 2. Output Power Capabilities

Output Voltage	12 to 44 vdc, depending on input voltage
Continuous Output Current	8.0 amps
Peak Output Current	16.0 amps
Auxiliary Power Output Supply	±15VDC @ 0.25 amps + 5 VDC @ 1 amp

Table 3. Electrical Characteristics

Switching Frequency	40 KHz
Form Factor	≤ 1.01
Gain (minimum) velocity mode	1.5 amp/mv
Gain (minimum) current mode	1.5 amp/v
Minimum input impedance	10 kohms
Offset	adjustable to zero
Drift	0.1%/°C
Signal Input Voltage Range	
Input 1 (Command Signal)	±10 vdc
Input 2 (Uncommitted)	±10 vdc
Tachometer Signal	±35 vdc
Current Monitor Output (TP3)	-0.25 Volts/Amp (4.0 Amps/Volt)

Table 4. Ambient Characteristics

Operating Temperature	0 to 40 °C
Storage Temperature	0 to 70 °C
Relative Humidity (non-condensing)	85%

Table 5. Operational Modes

Velocity amplifier with tachometer feedback
Velocity amplifier with EMF Sensing
Torque (current) amplifier

Table 6. Adjustments

Offset
Input Gain 1
Input Gain 2
Tachometer Gain
IR Compensation - EMF mode
Compensation - feed forward
Compensation - regulator gain
Continuous Current Limit
Peak Current Limit

Table 7. Inputs

Run Enable	15 V CMOS compatible
Clockwise Disable	15 V CMOS compatible
Counter Clockwise Disable	15 V CMOS compatible
Velocity Command	Analog Signal
Second Input	Analog Signal
Tachometer Feedback	Analog Signal

Table 8. Outputs

Fault Output	open collector limited to 20 mA
Current Monitor	analog output, -0.25 Volts/Amp, or 4.00 Amps/Volt
±15 VDC reference	@ 10 mA

Table 9. Indicators

Current Limit	RED LED
Over Current	RED LED
Over Voltage	RED LED
Amplifier Fault	RED LED
Power On	YELLOW LED

* Over Temperature is indicated by Over Current, Over Voltage and Amplifier Fault being illuminated all at once.

2. CONNECTIONS, CONTROLS, AND INDICATORS

2.1. Terminal Connections



Refer to Figure 8 for the location of parts described below.



TB1 and TB2 connectors are removable. This feature offers the convenience of easier wiring and also quick replacement of the amplifier.

Table 10. Signal Connector TB1

SIGNAL CONNECTOR	NAME	DESCRIPTION
TB1-1	TACH	<p><u>TACHOMETER INPUT</u> The (-) output of the tachometer is connected here. The (+) output goes to signal ground (TB1-2 or TB1-5).</p> <p>Note: Tachometer Polarity. Tachometer (+) is defined as the lead that has positive voltage on it when the motor/tachometer shaft rotates clockwise (CW), as viewed from the motor output shaft. Polarity may not always agree with color convention of the wire insulation.</p>
TB1-2	GND	<p><u>SIGNAL GROUND</u> These terminals are circuit ground of the KXA and the common of the ±15 Volt power supply. They are the connecting points for grounds of command and feedback signals and test instruments.</p>
TB1-3	IN-2	<p><u>COMMAND INPUT #2</u> Accepts the command voltage with a range of ±10 volts DC.</p>
TB1-4	IN-1	<p><u>COMMAND INPUT #1</u> Accepts the command voltage with a range of ±10 volts DC.</p>
TB1-5	GND	<p><u>SIGNAL GROUND</u> SAME AS TB1-2.</p>
TB1-6	ENABLE	<p><u>ENABLE</u> This terminal must be pulled low (grounded via external contact or jumper) in order for the amplifier to be enabled and operational.</p>
TB1-7	CW	<p><u>CLOCKWISE DISABLE</u> Grounding this terminal disables the drive in the clockwise direction.</p> <p>Note on CW and CCW disables: Usually the direction disable inputs (CW and CCW Disable) are used in conjunction with with limit switches at the end of travel. Making a permanent disable, either CW by jumpering TB2-1 to ground or CCW by jumpering TB2-2 to ground, assuming motor rotation is only needed in one direction, is not recommended. Doing so causes the amplifier to supply current in only one direction, which makes it a 2 quadrant amplifier instead of a 4 quadrant amplifier. This method also causes poor motor regulation.</p>
TB1-8	CCW	<p><u>COUNTER CLOCKWISE DISABLE</u> Grounding this terminal disables the drive in the counterclockwise direction.</p>
TB1-9	FAULT	<p><u>FAULT OUTPUT</u> This terminal is normally low and opens when an amplifier fault occurs or when the amplifier is DISABLED.</p>
TB1-10	+ 15V	<p><u>+ 15 VOLT DC SUPPLY</u> This terminal supplies +15 volts with respect to ground and provides up to 10 milliamperes of current.</p>
TB1-11	- 15V	<p><u>- 15 VOLT DC SUPPLY</u> This terminal supplies -15 volts with respect to ground and provides up to 10 milliamperes of current.</p>

Table 11. Power Connector TB2

POWER CONNECTOR	NAME	DESCRIPTION
TB2-1	M +	POSITIVE (M+) MOTOR INPUT.
TB2-2	M -	NEGATIVE (M-)MOTOR INPUT.
TB2-3	V -	NEGATIVE DC VOLTAGE INPUT A dc power supply (16 - 48 volts) can be connected here to run the amplifier and motor.
TB2-4	V +	POSITIVE DC VOLTAGE INPUT

**Table 12. AC Power Input Supply Module TB3
(Optional for KXA-48-8-16/PS/AUX)**

AC INPUT POWER CONNECTOR	NAME	DESCRIPTION
TB3-AC (ON OPTIONAL POWER SUPPLY)	AC	<u>AC INPUT</u> This input must come from an isolated step-down transformer. The secondary voltage is to be in the range of 12 to 37 VAC. PMI transformer types T-26-8 and T-48-8 are available.
TB3-AC (ON OPTIONAL POWER SUPPLY)		

Refer to Figure 8. On models which include the power input supply, terminals TB2-3 and TB2-4 will already have wires connected to them.

Table 13. Auxillary Power Output Supply Terminal J3 (Option)

AUXILIARY POWER OUTPUT SUPPLY TERMINAL J3	NAME	DESCRIPTION
J3-1	+ 5 V	+ 5 VOLTS DC @ 1 AMPERES
J3-2	+ 15 V	+ 15 VOLTS DC @ 0.25 AMPERES
J3-3	GND	GROUND
J3-4	- 15 V	- 15 VOLTS DC @ 0.25 AMPERES

See Figure 8 and Figure 9 for the location of the connector.

The terminal is a 4 pin female receptacle, J3, which supplies the 3 voltages plus ground.

A mating 4 pin male connector (P3) is needed to interface with J3. The part number is Dupont #65039-033, with pins #48116-000 for 30 - 22 AWG wire.

2.2. Controls

Controls consist of the following:

- Adjustment potentiometers.
- Selector switches.
- Reset switch.

2.2.1. Adjustment Potentiometers

Table 14. Adjustment Potentiometers

Adjustment Potentiometer	Description
Offset	Used to set the motor speed to zero when the commanded speed is zero. This adjustment eliminates any dc offset voltage in the servo loop from internal or external sources.
Input Gain 1	A gain adjustment for the command input. Fully CW = maximum gain, Fully CCW = 1/10 of maximum gain.
Input Gain 2	A gain adjustment for the second input. Fully CW = maximum gain, Fully CCW = 1/10 of maximum gain.
Tach (Gain)	A gain adjustment which is used to calibrate the motor speed to the command signal. CW adjustment decreases gain and increases motor speed. CCW adjustment increases gain and decreases motor speed.
Compensation (Feed-Forward)	Adjusts the transient response of the servo system to minimize overshoot and undershoot. This control introduces differentiation (lead) to the network. CW rotation increases compensation.

Adjustment Potentiometer	Description
Compensation (Regulator Gain)	Introduces additional compensation (necessary for some motors) by an adjustable integrator (lag) in the gain loop of a velocity regulator stage.
Continuous Current Limit	Sets the continuous current that can be delivered to the motor. Fully CCW = 0 amps, Fully CW = 8 amps.
Peak Current Limit	Sets the peak current that can be delivered to the motor. Fully CCW = 0 amps, Fully CW = 16 amps.
IR Compensation	Calibrates the amplifier for operation in the emf-sensing mode. CCW adjustment increases compensation.



NOTE

All customer interface adjustment potentiometers ("pots") (total of 8) are single-turn devices except for the Offset pot and Tach gain which are 22 turn multi-turn devices.

2.2.2. Selector Switches

Mode Selector Switch	NAME	DESCRIPTION
SW-1	EMF/Tach	Selects between tachometer feedback or emf sensing (with IR compensation) speed control.
SW-2	Speed/Torque	Selects between amplifier operation in the velocity or torque mode.

2.3. Indicators

Indicators consist of the following:

- LED indicators.
- Test points.
- Fuse.

2.3.1. LED Indicators

Table 15. LED Indicators

Indicator	Name	Description
LED1 (YELLOW)	Power On	
LED2 (RED)	Fault	This lights up for any fault condition and when the amplifier is DISABLED. Fault conditions can be latched or unlatched as indicated below.
LED 3 (RED)	Over Voltage	This lights up if the bus voltage exceeds an upper set limit. This can happen from a wrong supply, or a defective or absent regeneration clamp circuit. This is a latched fault.
LED 4 (RED)	Over Current	Fault condition. Lights when excessive current has occurred due to a ground short or bad component. This is a latched fault.
LED 5 (RED)	Current Limit	Current Limit has become active. This depends upon the set point of the continuous current limit pot.

Indicator	Name	Description
LED 2 LED 3 LED 4 (RED)	Over Temperature	Fault Condition. Lights when excessive temperature in the power output stage occurs. This is effected by a temperature sensor. This is a latched fault.



NOTE

If the amplifier goes into a latched fault it must be reset even if the fault condition is not present. Reset is accomplished the following ways:

1. Removing and restoring power
2. Disable and Re-enable

2.3.2. Test Points

Table 16. Test Points

Test Point	Name	DESCRIPTION
TP 1	VELOCITY SIGNAL MONITOR	A test point for a DVM or other instrument to measure or monitor velocity whether operating in DC Tachometer or emf sensing mode.
TP 2	CURRENT COMMAND MONITOR	A test point for a DVM or other instrument to measure or monitor the current command in the amplifier whether operating in velocity or torque mode.
TP 3	CURRENT MONITOR (DC AMPS OUT)	A test point for a DVM or other instrument to measure or monitor current in the motor. The scaling is -0.25 Volt/Amp, or 4.00 Amps/-Volt.
TP 4	Ground	Ground terminal for reference.

2.3.3. Fuse

(On Power Supply Module)

F1 Fuse A 12 amp, 250 volt ABC ceramic fuse in the DC power supply module that limits damage from shorts or component breakdowns.

3. INSTALLATION

The KXA comes packed in a anti-static bag. Remove carefully and check to be sure there is no damage from shipment. The KXA depends both on conduction and convection for dissipation. It may be used as a placed item for current requirements of 4

amps or less. For greater than 4 amps the amplifier must be mounted on a flat metal surface.

3.1. Mounting Instructions

The KXA chassis has four thru-holes for mounting. Refer to Figure 8. It is suggested to mount using 6-32 screws, 1 7/16 inch minimum length. For current requirement exceeding 4 amps be sure both flat surfaces are thoroughly clean and use the thermally conductive pad provided to interface between the amplifier and the mount surface. Peel off the protective backing to expose the sticky side and carefully stick-on the pad to the base of the amplifier. Tighten screws in 2 steps by first snugging, then tightening each in succession around the perimeter (not criss-cross).

3.2. Wiring Instructions



Do not power up until all amplifier connections are made to avoid possible damage to the amplifier, motor and your equipment.

Refer to Figure 10 and Figure 11 for Block and Wiring Diagrams and Figure 12 for Transformer Wiring as you go through the following procedure.

3.3. Power Wiring

Amplifiers without Power Input Supply Module

TYPE: KXA-48-8-16/AUX
 MODEL: 0088060003

Connect a DC voltage (16 - 48 vdc) to TB2 terminals
 V+ (TB2-4) & V- (TB2-3).

Connect the **NEGATIVE** of the DC power source to
 V- (TB2-3) and connect the **POSITIVE** of the power
 source to V+ (TB2-4). Use 16 gauge wire. See Figure
 1 below.

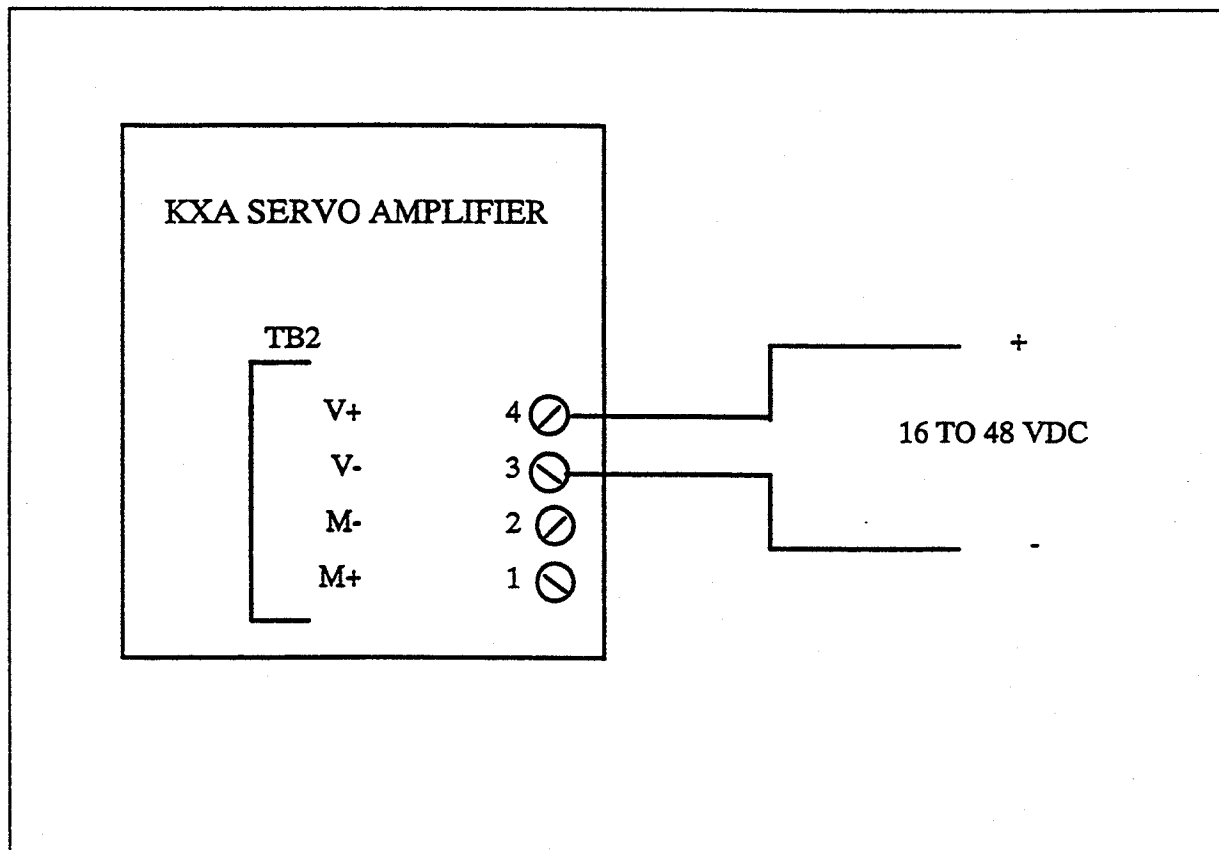

Figure 1. Power wiring for units without power input supply module

Amplifiers with Power Input Supply Module

AC input terminals on the power module. Refer to Figure 8 and Figure 9 and Figure 2 below.

TYPE: KXA-48-8-16/PS/AUX
 MODEL: 0088060004

Operation from AC requires a step-down isolated transformer. Secondary voltage must be in the range of 19 to 37 VAC. PMI offers a selection of power transformers made for this amplifier. Refer to the KXA Data Sheet or Amplifier Catalog for more information. These transformers have primaries that can be connected for either 120 or 240 VAC 50/60 Hz.

Connect the secondary of the transformer to the two

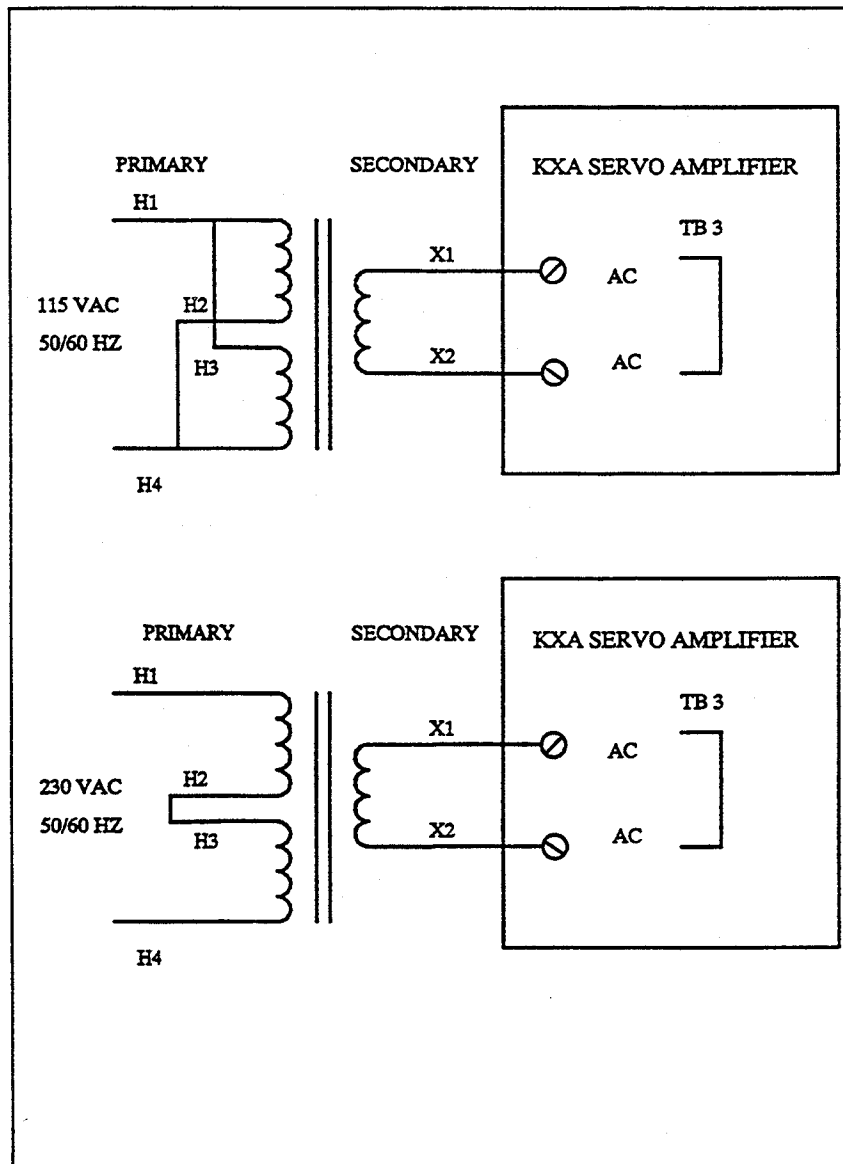

Figure 2. Power Wiring for Units with Power Input Supply Module

Motor Connections:

Using 16 gauge or larger wire, make the following connections:

From	To
Red Motor Lead (positive)	TB2-1
Black Motor Lead (negative)	TB2-2

With this wiring, the motor will rotate clockwise when the command signal on IN-1 (TB1-4) (command input) is positive.

You have now completed the connections to TB2. We will return to TB2 terminals 1 & 2 (the motor connections) later when we set current limits.

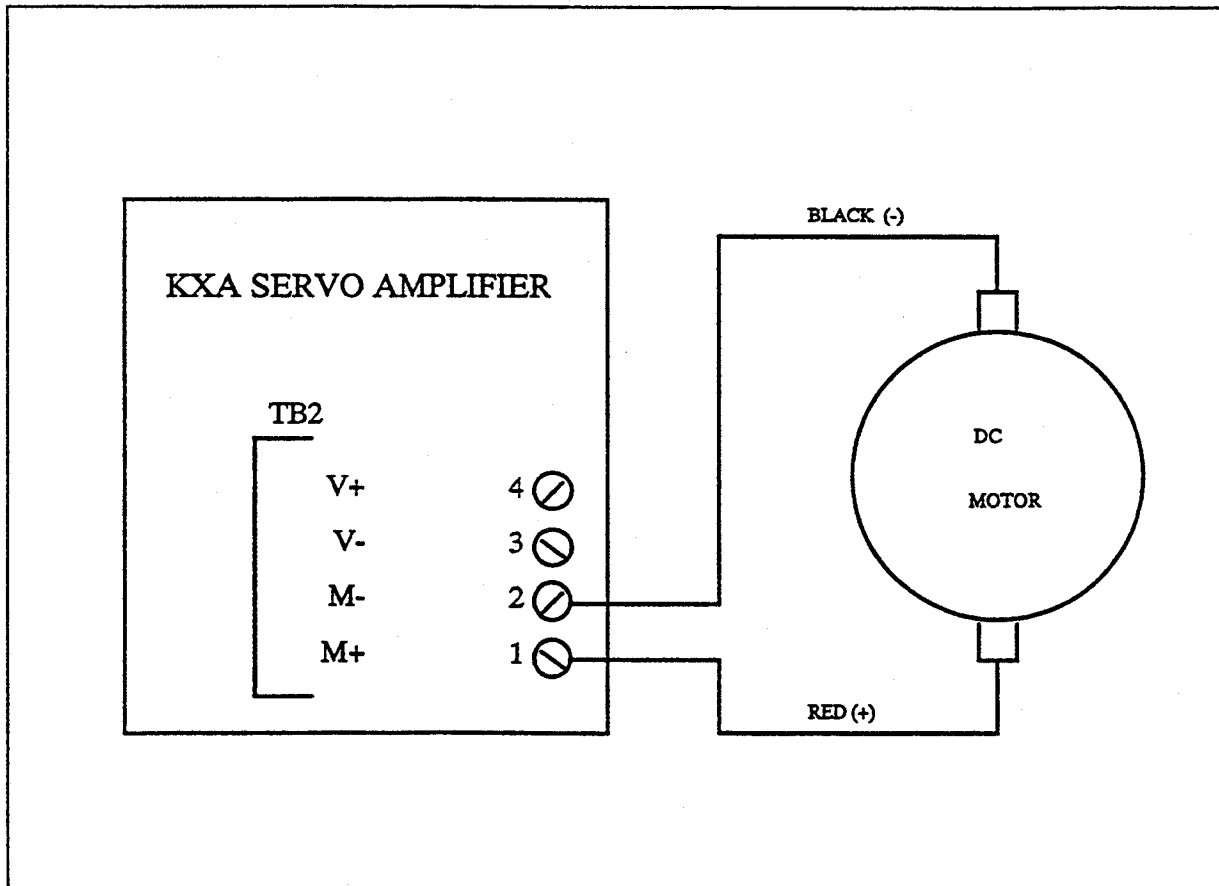

Figure 3. Motor Connections

3.4. Control Signal Wiring

All control connections are made on TB1. Follow the From/To table below.

Table 17. Control Signal Wiring

FROM	TO
TB1 Terminal 6 ENABLE	<u>Ground (TB1-2 or TB1-5)</u> This connection enables the amplifier and permits the motor to run. This can be done through an external contact from a master control or by using a jumper to keep the amplifier enabled at all times.
TB1 Terminal 4 INPUT 1	Command or Controller Signal This is the normal input for commanding the amplifier. NOTE: Use a shielded twisted pair with the shield connected either at the signal source only or TB2-2 only. (22-gauge wire OK.)
TB1 Terminal 1 TACHOMETER INPUT	Tachometer Connection If you are using a tachometer, connect the (-) output here and the (+) output to the signal ground at TB1-2. See Figure 13.

NOTES:

1. Tachometer polarity is defined in Section 2.1. A quick way to determine polarity correctly is as follows:

Connect a voltmeter (0 to 10 V range.) to the output of the tachometer.

Rotate the motor clockwise (by applying a dc signal to motor terminals or rotate the motor output shaft by hand).

If the meter reads positive, Tach (+) is connected to the meter's red lead.

If the meter reads negative, Tach (+) is connected to the meter's black lead.

2. Tachometer voltage must not exceed ± 35 volts.
3. Use a shielded twisted pair with the shield connected to TB1-2 only. (22-gauge wire.)

Table 18. Additional Control Signal Wiring

Connector	Name	Description
TB1-2 and TB1-5	SIGNAL GROUND	This is the return for the command and tachometer signals.
TB1-3	Input 2	<u>Additional Command</u> This second input is uncommitted. It can be used instead of Input 1 if desired or in conjunction with Input 1 as a trim or compensator in some applications. Input 2 has the same gain range as Input 1.
TB1-7	Clockwise Disable	<u>Logic Control</u> Driving this terminal low or grounding it disables the drive in the CW direction.
TB1-8	Counter Clockwise Disable	<u>Logic Control</u> Driving this terminal low or grounding it disables the drive in the CCW direction.
TB1-9	Fault Output	<u>Logic Control</u> When the amplifier faults the status at this terminal changes from low to open. This open collector can be used to pass current up to 20 milliamperes.

Connector	Name	Description
TB1-10	+15 Volt Reference	<u>Signal Device</u> This is a voltage source of +15V with respect to ground for small signal utilization. Current draw is limited to 10 milliamperes. TB1-11
TB1-11	- 15 Volt Reference	<u>Signal Device</u> This is a voltage source of -15V with respect to ground for small signal utilization. Current draw is limited to 10 milliamperes. TB1-11

To minimize noise pick-up all analog signal inputs not being used are to be grounded. For example if Input 2 is not being used connect a short jumper between it and ground (TB1-2 or TB1-5). Do the same if Tachometer Input is not being used.



4. SETUP INSTRUCTIONS

The first stage in setting up the KXA, regardless of which of the three modes you may operate in, is setting the current limits. After carrying out the steps of Section 4.1 you may proceed to the section for the selected mode of operation.

APPLICATION NOTE: Using the KXA as a Self-Contained Speed Controller

The KXA may be operated as a self-contained speed controller by supplying a command voltage from the wiper arm of a potentiometer. A 10K potentiometer with series resistance R_s can be powered from the internal +15 volt and -15 volt supplies available on the KXA. Figure 13 and Figure 14 show schemes for connecting the potentiometer for one direction and two direction speed control, with and without tachometer feedback. Use the R_s values shown below. Consult PMI for motors or tachometers with Back-EMF constants outside of ranges shown.

Table 19. Suggested R_s Values

R_s (ohms)	Back-EMF Constant Range (V/KRPM)
33 K	1 to 5 (ferrite motors)
5 K	5 to 20 (alnico motors 9 & 12 size)

4.1. Setting Current



Follow each step sequentially. Do not apply power to the KXA until instructed to do so.

STEP

- C1. Set Speed/Torque slide switch SW-2 to the TORQUE position. (See Figure 8.)
- C2. Preset the current adjustment potentiometers to the following settings.

 Continuous Current Limit:
 1/4 turn CW (1/4 current)

 Peak Current Limit:
 Fully CW (maximum current)
- C3. Connect a jumper wire across motor terminals M+ (TB2-1) and M- (TB2-2). Use 16 or 18 gauge wire. (See Figure 4 on next page.)
- C4. Connect a DVM (set to 5 to 10 volt range) to the current monitor test point on the

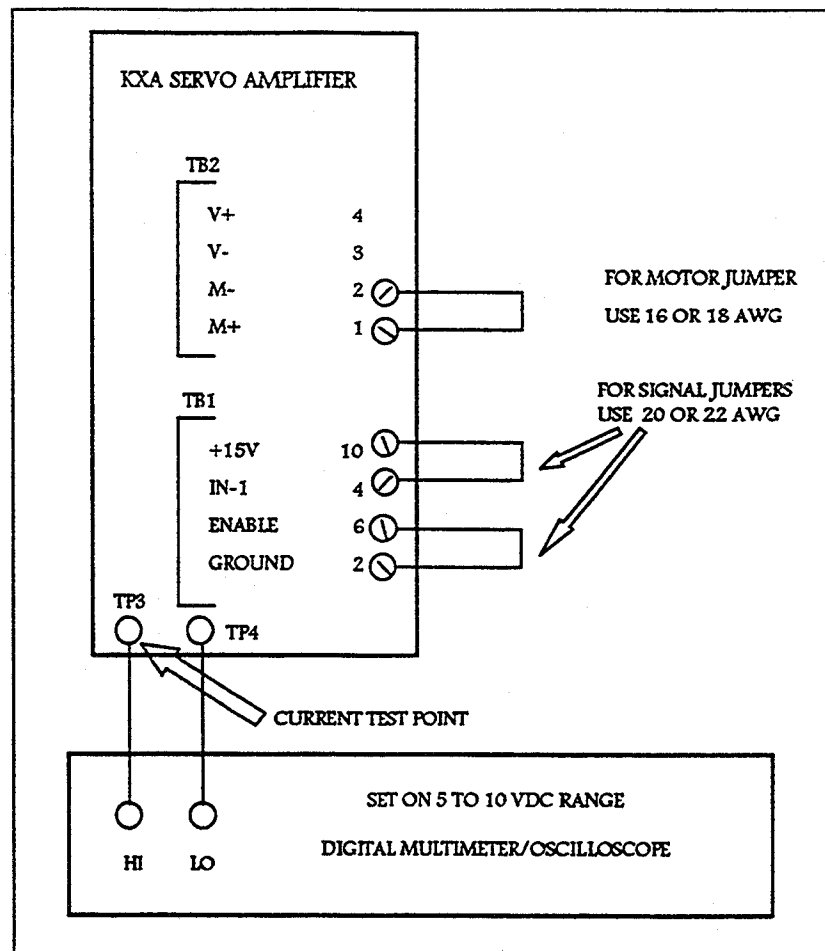

Figure 4. Wiring Diagram for Setting the Current Potentiometers.

amplifier, TP3 and ground. Note: An appropriate current probe may be clamped around the jumper wire instead if so desired.

C5. Turn on power to the amplifier.

The YELLOW LED indicator will illuminate and also the RED FAULT LED indicator will be illuminated until the amplifier is enabled (next step).

C6. Enable the Amplifier.

For setting-up purposes, continually enable the amplifier by installing a jumper wire between ENABLE (TB1-6) and GROUND (TB1-2).

C7. Provide Command Signal.

Connect a jumper from the +15V terminal TB1-10 to the command input, IN-1, at TB1-4, or provide a 10 Vdc analog voltage from external source to the input command (IN-1) terminal.

C8. Check Continuous Current Limit:

Turn the Continuous Current Pot fully CW to allow maximum current flow. The DVM should read -2.00 Volts. This corresponds to 8 Amps which is the maximum continuous current the KXA delivers.

C9. Check Peak Current:

An oscilloscope or peak reading voltmeter is preferred for accurately setting peak current but the setting may be approximated with the DVM.

The reading will go up to -4.00 Volts (which corresponds to 16 Amps) for about 1.0 seconds then step back to 2 Volts.

C10. Set the Current Limits - Using Pot Setting Arrows:

The continuous and peak current adjustments are 300° turn pots. The settings can be roughly made by the position of the arrows on the pots. Listed below is a tabulation that shows pot positions at 7, 11, 1 and 4 o'clock and corresponding peak and continuous current limits. Current level is not linear with the position of the pot. The pot setting for a desired current can be estimated from this tabulation data.

Table 20. Pot Settings for Desired Current

Peak Position	Continuous Position	Peak Current (Amps)	Continuous Current (Amps)
ANY P	C1	0	0
P2	C2	5.6	3.0
P2	C3	5.6	5.0
P2	C4	5.6	5.0
P3	C2	11.0	3.0
P3	C3	11.0	5.0
P3	C4	11.0	8.0
P4	C2	16	3.0
P4	C3	16	5.6
P4	C4	16	8.0

Fully CCW (7 o'clock) positions of the current-setting pots on the KXA may cause uncontrolled rotation of the motor. It is suggested these pots not be set below 1/4 turn.



C10A. Set the Current Limits - Using Instruments.

Make the rough settings via the pot arrows as per Step C10 above. With command voltage present observe the DVM. When the reading stabilizes make note of it and

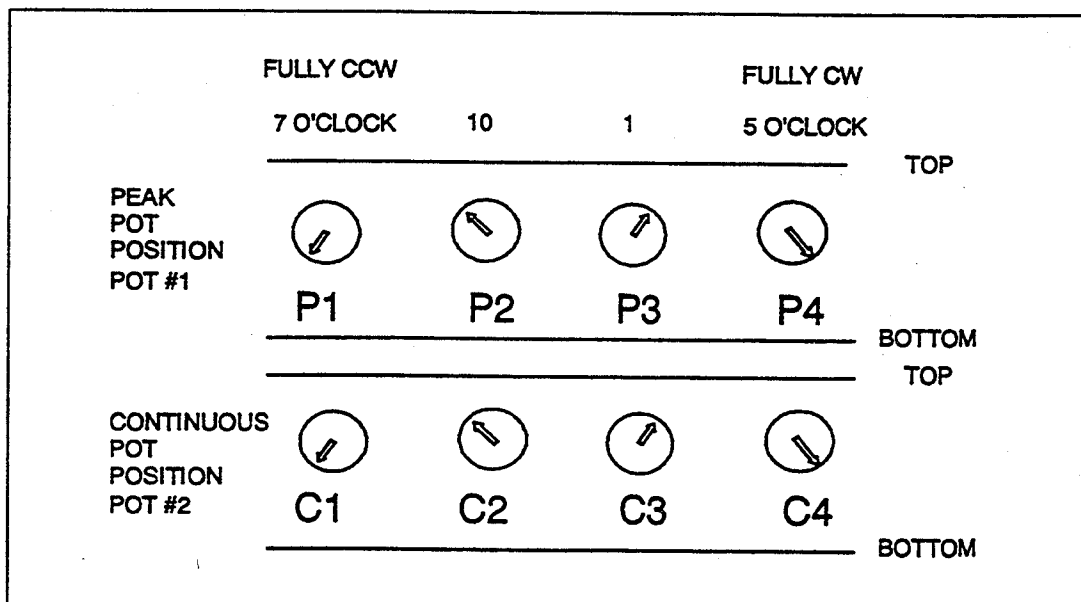

Figure 5. Current Limits Pot Settings

calculate the continuous current flowing.

Scaling is -0.25 V/Amp for the KXA. Readjust the continuous current pot for the desired current as reflected by the voltage on the DVM. With proper conservative motor sizing, this current setting should not exceed 80% of the continuous current rating of the motor. Consider an example where a setting of 6 amps is desired. To obtain this, adjust the Current Limit pot until you read -1.50 V.

The setting of the peak current requires repeat interruptions using the ENABLE command after allowing 1 or 2 seconds of rest time. As you turn the peak current pot down (CCW) the peak reading on the scope will go lower.

Scaling at TP3 is -0.25V/A
 Example: 12A = -3.0V reading.

C11. Check for Negative Current:

Disconnect the jumper at the +15V point (TB1-10) and touch it and hold it at the -15V point (TB1-11) while observing the scope or DVM. You will now read corresponding negative voltages which indicate that current is now in the opposite direction.

You have now completed setting up your KXA for current limits. The KXA may be operated in three different modes:

- Torque (Current) Mode
- Velocity mode with Tachometer
- Velocity mode with EMF sensing (IR Compensation)

Leave the unit powered and connected and proceed to the section corresponding to your choice of operating mode.

4.2. Torque Mode

The Torque Mode removes velocity feedback, pre-amplification, and compensating circuits. It is mostly

used with positioning controllers that externally close the velocity loop and compensate the servo loop. Torque Mode can also be used in tension control applications. Consult PMI Applications Engineering.

The KXA, upon completion of the current-setting steps above, is also set up in the Torque Mode. All that is required is to check that the unit delivers current in proportion to the voltage command. Leave power on, all connections intact, and proceed:

STEP

T1. Set Adjustments of Potentiometers (See Figure 8)

Set the following pots as follows:

Table 21. Pot Settings

Function	Setting	Pot #	Condition
GAIN	FULLY CCW	POT 2	MINIMUM GAIN
OFFSET	MID- POINT	POT 3	NEAR BALANCE



NOTE

The Tach Gain, Compensation, Regulator Gain, and IR Compensation Pots are not used in Torque Mode.

T2. Apply an Adjustable Command Voltage to TB2-3.

T3. Check Offset.

With zero command voltage applied trim for a zero reading on the DVM with the Offset Pot.

T4. Check for Current proportional to Input Voltage.

The KXA provides current proportional to voltage as follows:

1.6 Amps/Volt or 0.625 Volts/Amp

Check that your KXA produces current in accordance with the following table:

Table 22. KXA Current Checks

Input Voltage (Volts)	Output Current	Reading at TP3
1	1.6	0.4
2.5	4	1.0
5	8	2.0
10	16 PEAK	4.0 PEAK

These proportions are correct when the Input Gain Pot is set near to minimum (CCW). If you are working with small command voltages you may choose to adjust the input gain which has range of 10 to 1. This means that with the gain pot fully CW you can command 16 Amps with 1 volt. With this setting, any voltage higher than about 1.2 volts will saturate.

T5. Turn off the Power so that you can connect the motor.

T6. Connect the Motor.

Remove the jumper between TB2-3 and TB2-4 and connect the motor leads.

T7. Restore Power and Check Motor

Apply power to the KXA again. With zero command the motor will have zero current and no torque. Arrange to hold or brake the motor shaft. As you increase the command voltage the motor will get current proportionately. This will be evident by monitoring the current at TP3 with the DVM, and by "feeling" the torque on the motor shaft. If the motor is left unloaded it will run up to full speed produced by the bus voltage since there is no velocity loop in the torque mode.

Torque mode is used by some positioning systems in which velocity and position loops are closed external to the amplifier. When the KXA in torque mode is interfaced to such a system and a zero command is made, the motor will be held in a locked-in position.

This concludes the adjustment and setup procedure for torque mode.

4.3. Velocity Mode with Tachometer



NOTE

Follow each step sequentially. Do not apply power to the amplifier until instructed to do so.

STEP

- V1. Remove the jumper temporarily from TB1-6. This disables the amplifier.
- V2. Remove the jumper across motor output.(From Section 4.1)
- V3. Set the Speed/Torque switch SW-2 (Figure 8)

Set the switch to Speed position.

- V4. Check the EMF/Tach switch SW-1

Set the switch to Tach position.

- V5. Preset the adjustment potentiometers (See Figure 8)

The potentiometers should be set as follows:

You have already set the current pots from Section 4.1.

Table 23. Potentiometer Settings

Function	Setting	Condition
Input Gain 1	Fully CCW	Minimum Gain
Input Gain 2	Fully CCW	Minimum Gain
Tach Adjust	Mid-point	Medium Gain
Compensation	3/4 CW	Nearly Max
Regulator Gain	Fully CCW	Minimum Compensation
IR Compensation	Not Used	—
Offset	Mid-point	Near Balance

- V6. Apply Power to the amplifier. The motor will not move because the unit is disabled.

- V7. Connect command voltage to TB1-4 and TB1-5.
- V8. Safety Check Method of Enabling Motor.
 - a. Be sure you have a zero-volt command signal or ground the Voltage Command input terminal (TB1-4).
 - b. Touch the enable jumper to TB1-6.

The motor will now be powered. It should be in a locked position or rotating slowly. If it runs away at high speed, immediately disable it by pulling away the jumper wire from TB1-6. Reverse the tachometer leads and try again. When you get the motor working properly, permanently reconnect the enable jumper.

V9. Adjust Offset

Set the command voltage to zero. If the motor is slowly rotating, adjust the Offset pot until it stops.

V10. Trim Compensation Pots (Conditional)

Normally, for PMI ServoDisc motors the position of the two compensation (Compensation and Regulator Gain) pots will remain per the pre-settings in Step V5 and provide a good general tuning. If you are driving other motors, especially iron core motors, you may hear an audible tone emitting from the motor. If so, you can eliminate this condition by slightly turning the Regulator Gain pot up from fully CCW until the noise stops.



Fine tuning of the compensation pots, which will be necessary in critical servo applications, is described in Step V10.

V11. Adjust motor speed

Determine the maximum command voltage that will be available. Usually it is ± 10 vdc. When this is the voltage level being used, the Input Gain pot remains at minimum (fully CCW). The Input Gain pot has a range of 10:1

so that the KXA can handle a command signal as small as ± 1 vdc.

Apply the maximum command voltage. The motor will run up to some speed. Determine this speed by using a hand tachometer or measuring the voltage delivered by the motor tach at TB1-1. Using the Tach Adjust Pot, set the desired motor speed (example 3000 rpm for 10v command). CW adjustment increases the speed of the motor (less tach gain), and CCW adjustment decreases it (more tach gain).

Check the speed range and tracking by applying various command levels. Also check full speed in the opposite direction by commanding a maximum negative voltage.

V12. Adjust Compensation

As a coarse adjustment, the Compensation pot may be left at the 3/4 CW position and the Regulator Gain pot either fully CCW or as per Step V10. This provides satisfactory performance in a large majority of cases. To optimize the response of the servo loop, compensation may be fine-adjusted in accordance with the procedure below.

Fine Adjustment of Compensation

(Requires an oscilloscope and a function generator)

This procedure is used to optimize the transient response of the servo system by minimizing overshoots and undershoots. The response of the servo loop can be observed by using an oscilloscope and a function generator. Connect the oscilloscope to the tach feedback signal, which will indicate motor velocity in terms of voltage. Connect the function generator to the Velocity Command input terminal. The output of the function generator should be a low frequency square wave. The frequency must be low enough to enable the motor to reach a steady state speed.

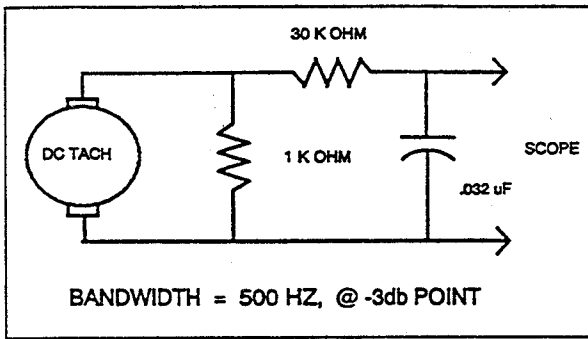

Figure 6. Recommended RC Filter Network

The square wave will provide a step input to the system. If your tachometer signal has high ripple content, the following RC filter network is recommended. (Figure 6).

If you need a lower cut-off frequency, use a higher value for the capacitor.

The amplitude of the square wave should be adjusted to your desired operating speed. The scope should be triggered on the rising edge of the square wave. If there is a storage scope available, a single trace of the system response can be stored.

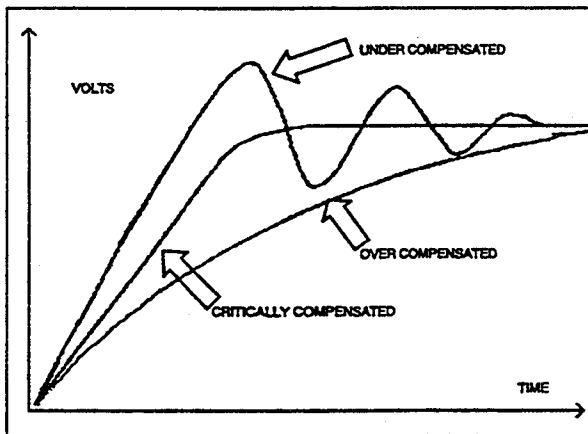

Figure 7. Oscilloscope Wave Shapes

The scope should display one of the wave shapes in Figure 7.

Set the Compensation adjustment to obtain a critically compensated response. This will be the fastest response without overshoot. If the system is over-compensated (slow response with overshoot), turn the Compensation pot CCW. If it is under-compensated (overshoot and oscillation), turn it CW. Pot position depends on many factors, such as motor type,

tachometer type, load inertia, load friction, speed, and gain. After tuning Compensation you may try to further improve the response to the step signal by slowly turning up Regulator Gain (CW). Advancing this pot too far will cause oscillation which will immediately show on the scope at the top of the constant speed portion. Keep this pot set below the instability point.

V13. Readjust the Offset

Apply a zero voltage command to the amplifier. If the motor is turning, adjust the Offset pot to bring it to a stop.

This concludes the adjustment and setup procedure for velocity mode applications using a tachometer.

4.4. Velocity Mode with EMF Sensing



NOTE
Follow each step sequentially. Do not apply power to the amplifier until instructed to do so.

STEP

- VE1. Remove the jumper temporarily from TB1-6. This disables the amplifier.
- VE2. Remove the jumper across motor output. (From Section 4.1)
- VE3. Set the Speed/Torque switch SW-2 (See Figure 8)

Set the switch to Speed position.

- VE4. Check the EMF/Tach switch SW-1 (See Figure 8)

Set the switch to EMF position.

- VE5. Preset the adjustment potentiometers (See Figure 8)

The potentiometers should be set as follows:

You have already set the current pots from Section 4.1.

Table 24. Potentiometer Settings

Function	Setting	Condition
Input Gain 1	Fully CCW	Minimum Gain
Input Gain 2	Fully CCW	Minimum Gain
Tach Adjust	Not Used	
Compensation	3/4 CW	Nearly Max
regulator Gain	Fully CCW	Minimum Compensation
IR Compensation	Fully CW	Minimum
Offset	Midpoint	Near Balance

VE6. Apply Power to the amplifier. The motor will not move because the unit is disabled.

VE7. Connect command voltage to TB1-4 and TB1-5 and set to zero. (Or ground TB1-4)

VE8. Enable amplifier with contacts or jumper from TB1-6 to TB1-5.

VE9. Adjust Offset

Adjust Offset pot to stop any rotation of motor.

VE10. Trim Compensation Pots (Conditional)

Normally, for PMI ServoDisc motors the position of the two compensation (Compensation and Regulator Gain) pots will remain per the pre-settings in Step VE5 and provide a good general tuning. If you are driving other motors, especially iron core motors, you may hear an audible tone emitting from the motor. If so, you can eliminate this condition by slightly turning the Regulator Gain pot up from fully CCW until the noise stops.

VE11. Test motor speed control

Apply some positive and negative command voltages. The motor should rotate clockwise and counterclockwise, respectively.

VE12. Adjust IR Comp Pot

Return the motor to zero speed (zero command). Slowly turn the IR Comp pot CCW until you hear a low frequency noise from the motor (motor may also begin to rotate slowly at this point). Back off (turn CW again) until the noise (oscillation) stops. Under loaded conditions, the motor may start oscillating again. In this case, repeat this adjustment.

VE13. Readjust Offset Pot.

If necessary, readjust the Offset pot to stop the motor.

VE14. Adjust Motor Speed

The Gain pot is used to calibrate the motor speed to the command signal. Apply the maximum command voltage you will be using (± 10 vdc maximum), and adjust the Gain pot until the motor is running at the desired speed.

Check the speed range and tracking by applying various command levels. Also check operation in the opposite direction by applying negative voltages.

You may have to limit the command voltage to a maximum value less than ± 10 Volts if you have a mismatch of small motor and high bus voltage. PMI recommends specific step-down transformers for motor types selected. Check the PMI KXA brochure.

VE15. Readjust Offset

Set the command voltage to zero. If the motor is slowly rotating, adjust the Offset pot until it stops.

VE16. Fine Tuning

To optimize performance, you may touch up adjustments of four pots: Compensation, Regulator Gain, IR Comp Pot, Offset Pot.

Start by slowly turning Compensation Pot CW until you hear a high-pitched noise

from the motor. Then back off CCW until it stops, but no further. If you do not get the high pitched noise leave this pot fully CW and slowly turn Regulator Gain CW until you hear the noise then back away.

Now readjust the IR Comp pot as in Step VE10. You may have some slight interaction with the Compensation pots. If you hear a high pitched noise readjust Regulator Gain, and maybe Compensation to stop it. With this second adjustment of the IR Comp pot, you may have to readjust the Offset pot slightly to bring the motor to a stop.

You have now completed adjustments of the KXA for operation in the EMF mode. Keep in mind that this mode does not give the same level of stiffness, stability and speed regulation as a motor/tach combination. In many applications, however, it will provide satisfactory performance.

5. TROUBLESHOOTING

When problems occur in servo systems, any of the components can be suspected. Listed below is a quick-check procedure to follow if you think the problem is with the KXA. The intent and scope of this procedure is to establish whether the KXA amplifier is functioning properly or not.

It is recommended that you go through these quick checks before consulting PMI. If you determine that the amplifier is faulty, we recommend that you return it to the factory for repair.

5.1. Indicators

The KXA has 5 LED'S, one fuse, and a test point for current monitoring. Refer back to Section 2.3. The LED'S are there to give quick clues for amplifier non-performance.

If any of the red LED'S should light, you should initially try clearing the fault with the ENABLE command, or interrupting and then restoring main power.

Similarly if the 12 Amp fuse is blown, replace it to see if that restores operation.

If the fault conditions repeat, then proceed on.

5.2. Quick-Check Procedure

1. Remove power from amplifier.
2. Check and/or replace 12 Amp fuse F1 on power supply.
3. Remove all signal inputs to amplifier.
4. Remove motor leads and put a jumper across TB2-1 and TB2-2. Use 16 gauge wire.
5. Put the SW-2 Speed/Torque switch to Speed mode.
6. Turn the Offset pot fully CW.
7. Turn the Current Limit pot fully CCW (minimum current).
8. Apply power to the KXA.
9. Check Fault Indicators.
 - A. If fuse blows, the KXA has shorted components.
 - B. If the Overcurrent red LED lights, the KXA has bad components.
 - C. If the Overvoltage red LED lights, check the DC supply voltage of the amplifier. The light will come on somewhere in excess of 56 volts. Recommended supply voltage is not to exceed 50 volts DC. If the light is on with proper supply voltage then the KXA has bad components.
 - D. If the Power-On yellow indicator does not light, check the supply voltage. If it is greater than 11 volts, the KXA has bad components.
10. If the fault indicators are OK, make the following measurements with the DVM:

A. Input Power

1. If you are using a DC input, check across TB2-3 and TB2-4 for proper voltage and polarity. (Range must be 16 to 48 VDC)

B. Logic Voltages

1. Check for +15 VDC $\pm 5\%$ between TB1-10 and ground.
 2. Check for -15 VDC $\pm 5\%$ between TB1-11 and ground.
11. If above voltages are OK, connect the DVM at TP3 and ground.
 12. Enable the amplifier by putting a jumper from TB1-6 to ground.
 13. Turn the Peak and Continuous Current Limit Pots fully CW to allow maximum current. The DVM should run up to -4.00 VDC $\pm 10\%$ and then settle in at -2.00 VDC $\pm 10\%$.
 14. Turn the Offset pot fully CCW. The DVM should now read 2.00 VDC $\pm 10\%$.
 15. Check Bus Voltage (If you have Power Supply). With maximum current flowing, check for proper bus voltage from power supply by measuring across TB2-3 and TB2-4.

If the KXA passes all of the above checks, it is operating properly.

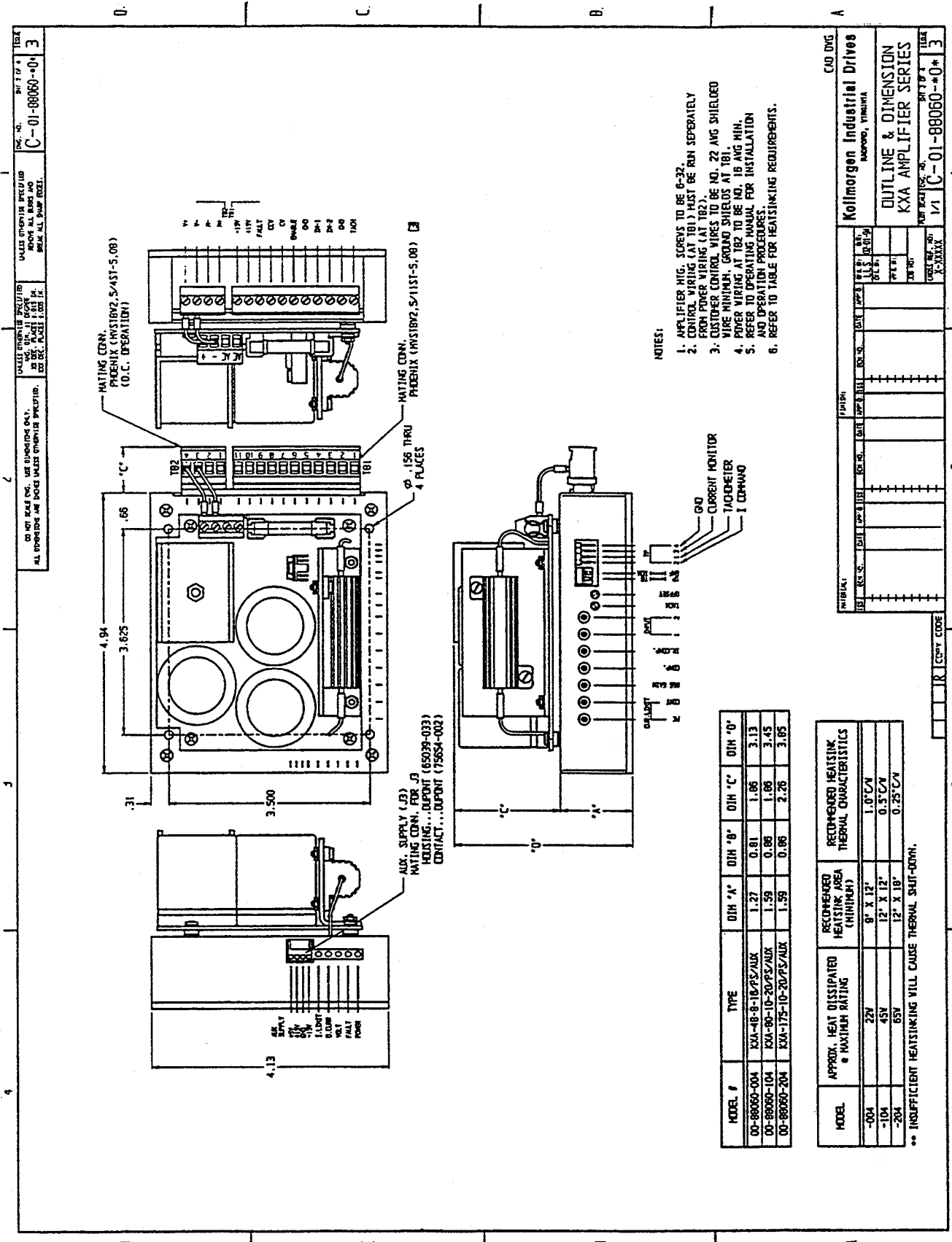

Figure 8. Outline Drawing C-01-88060-*0* Sheet 1 of 4

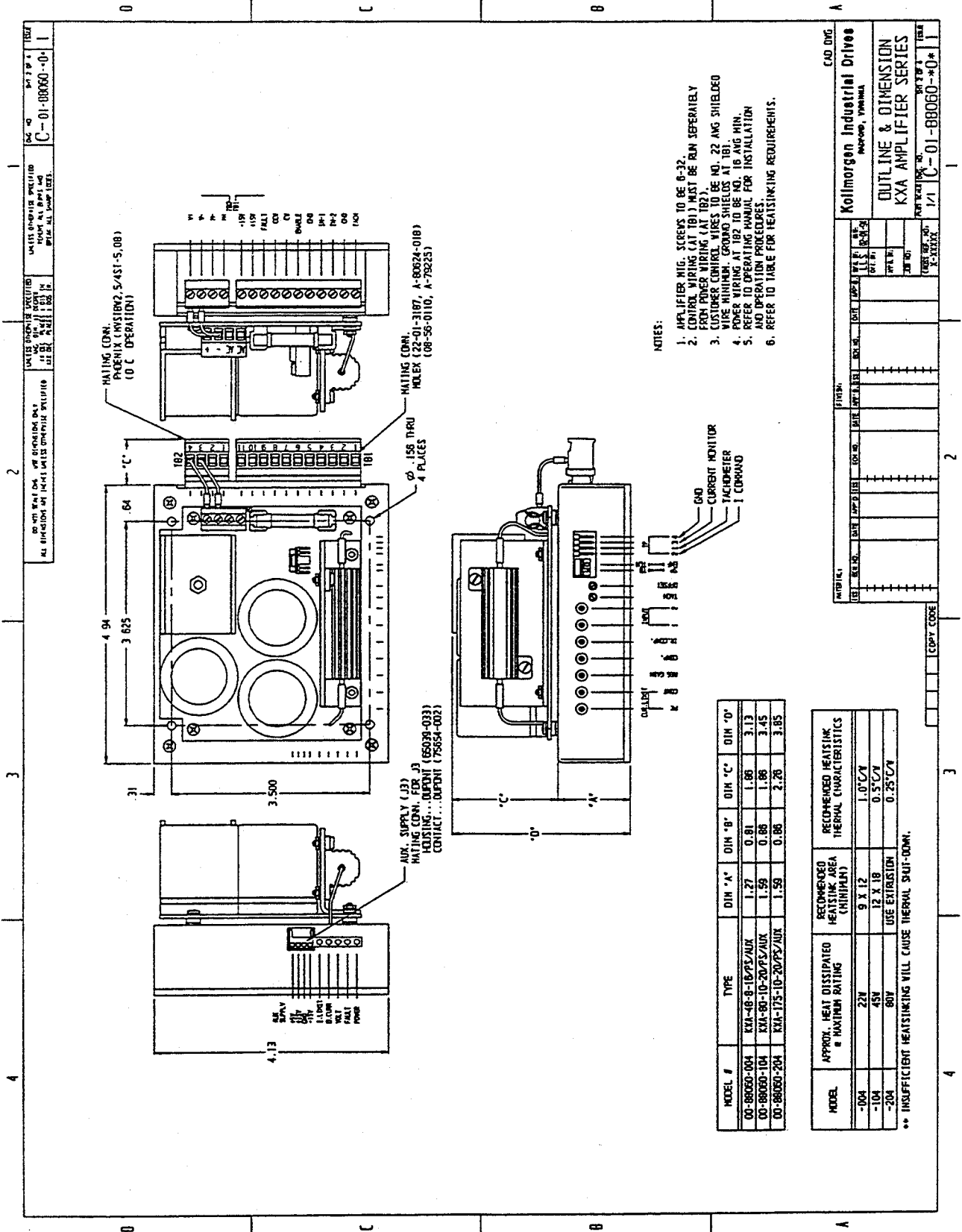

Figure 9. Outline Drawing C-01-88060-*0* Sheet 2 of 4

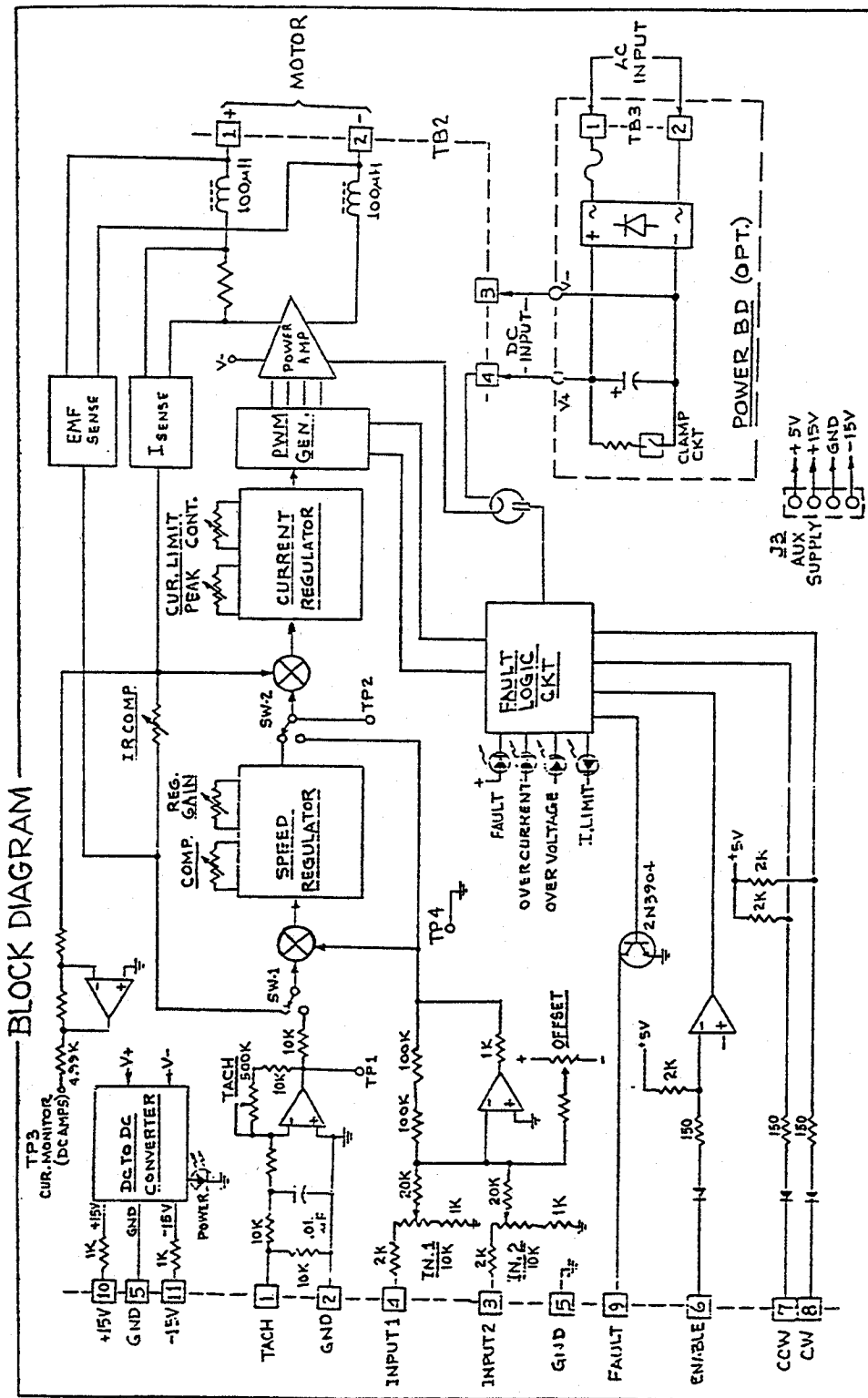

Figure 10. Block Diagram

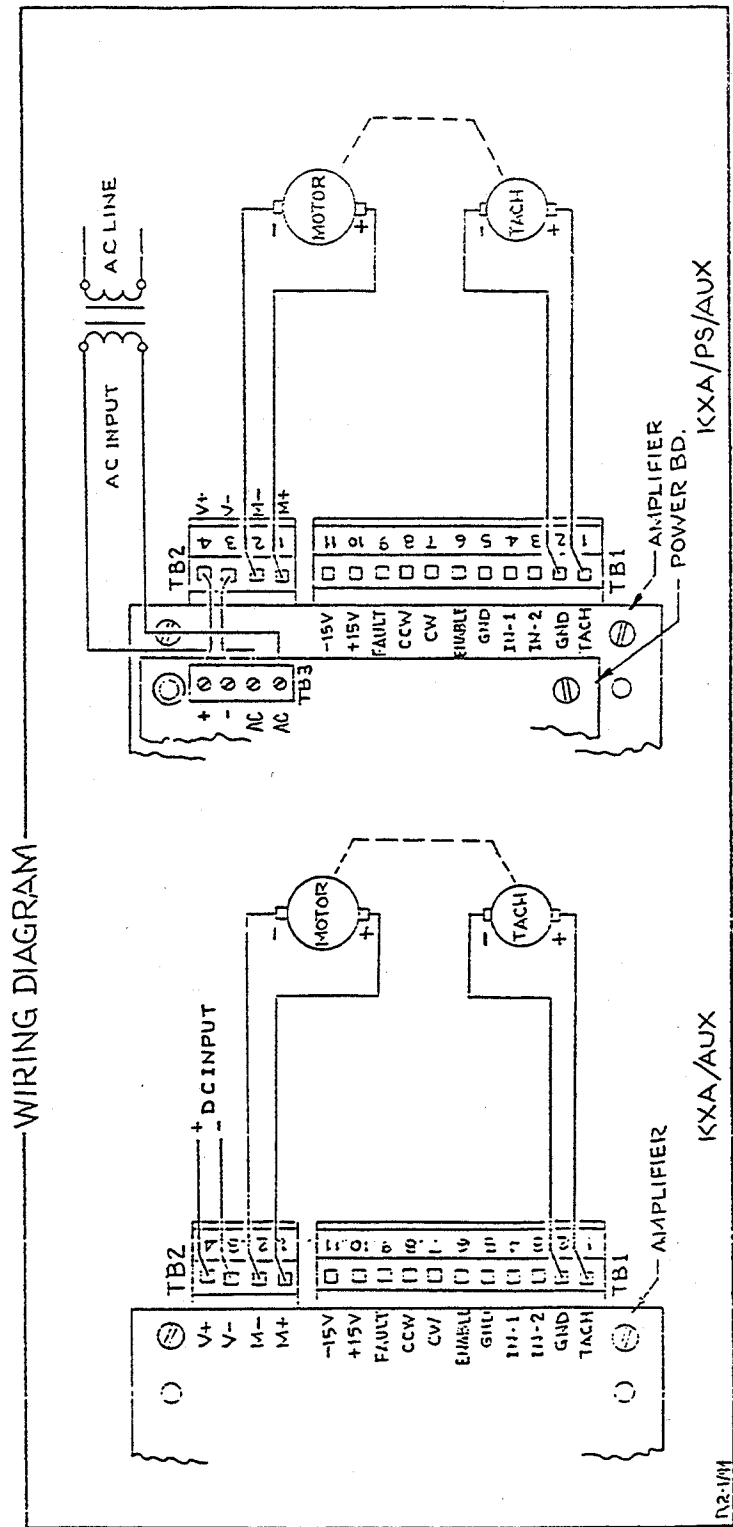

Figure 11. Wiring Diagram

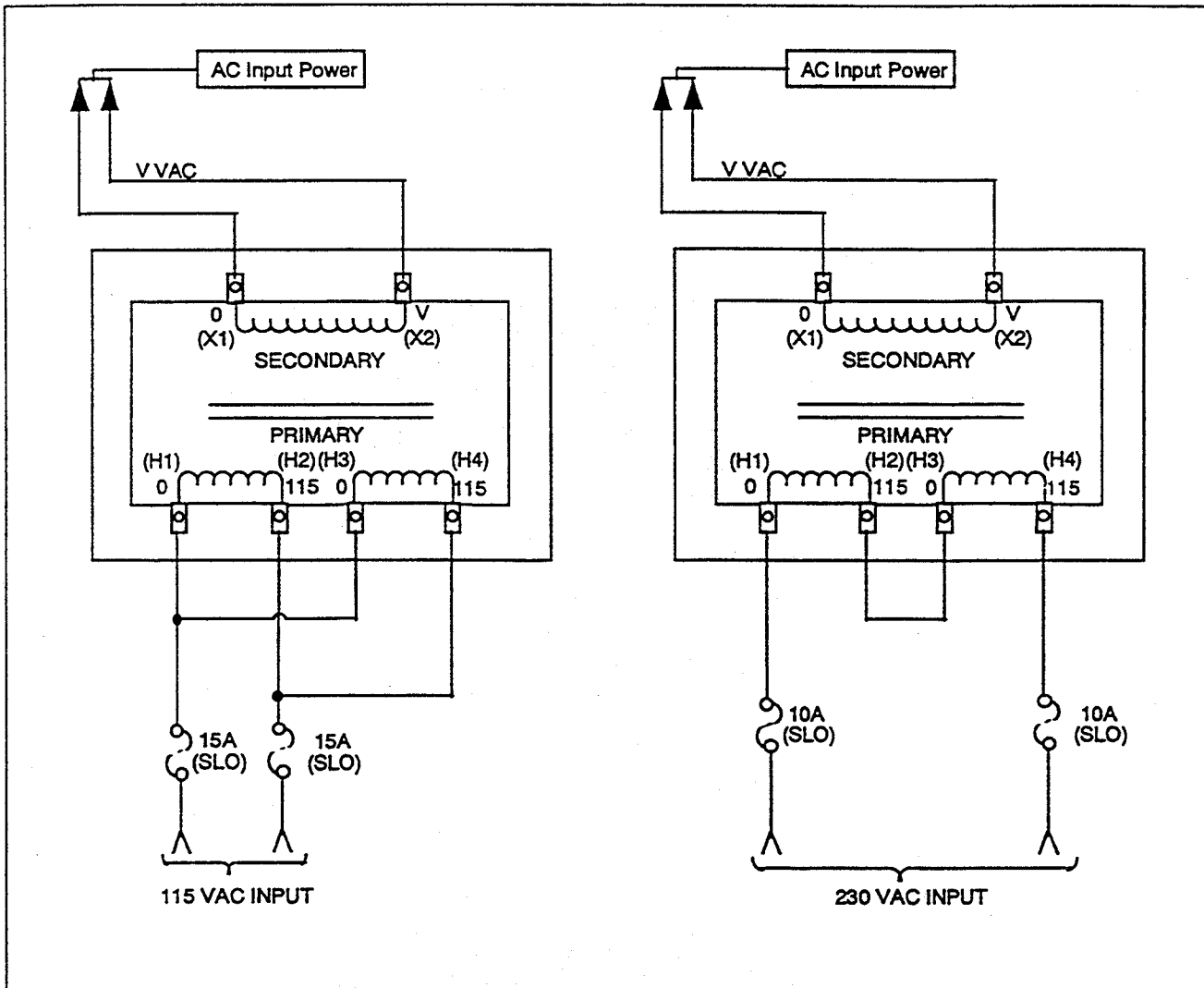

Figure 12. Transformer Wiring

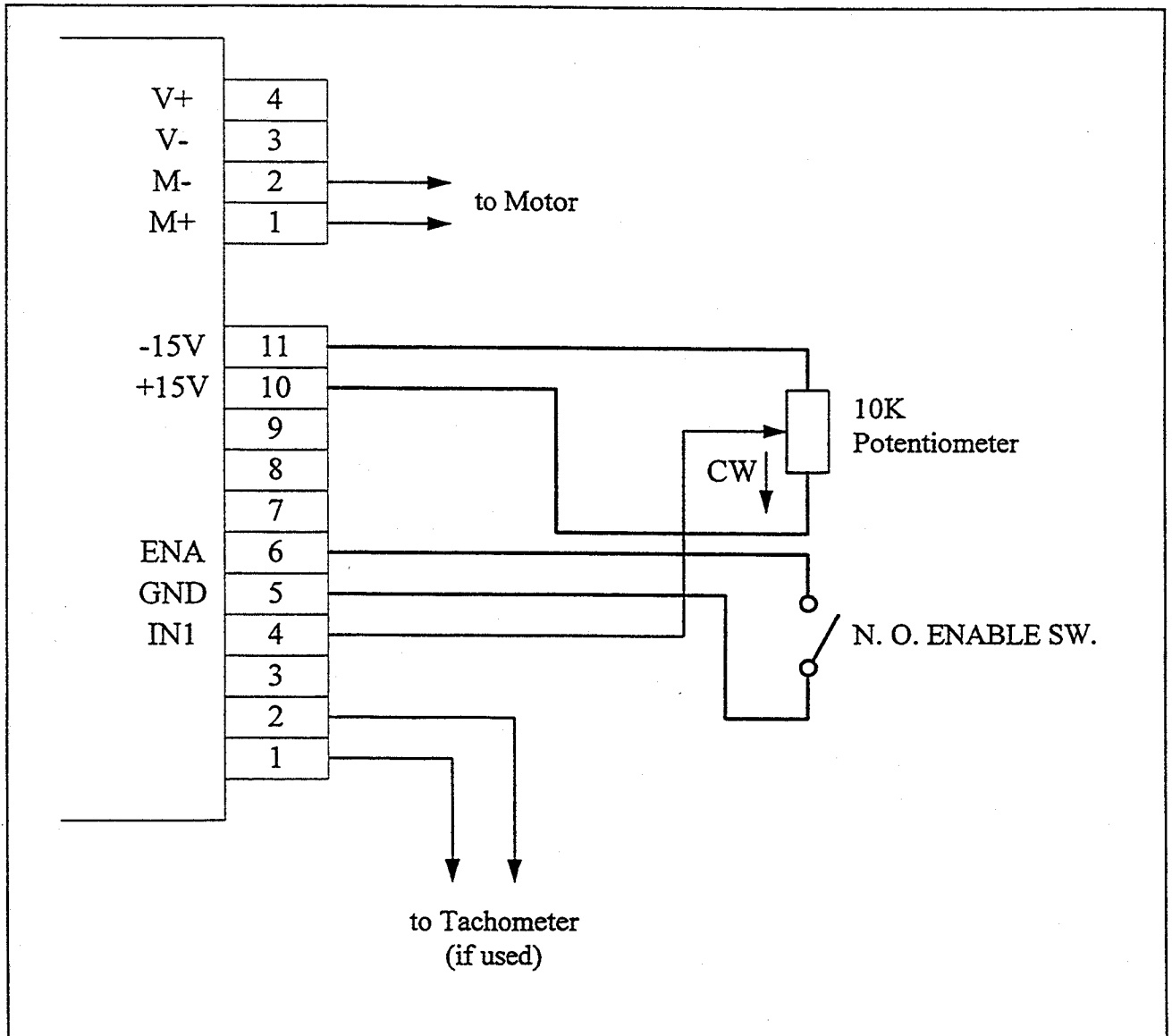

Figure 13. Schemes for Controlling Speed with a Potentiometer

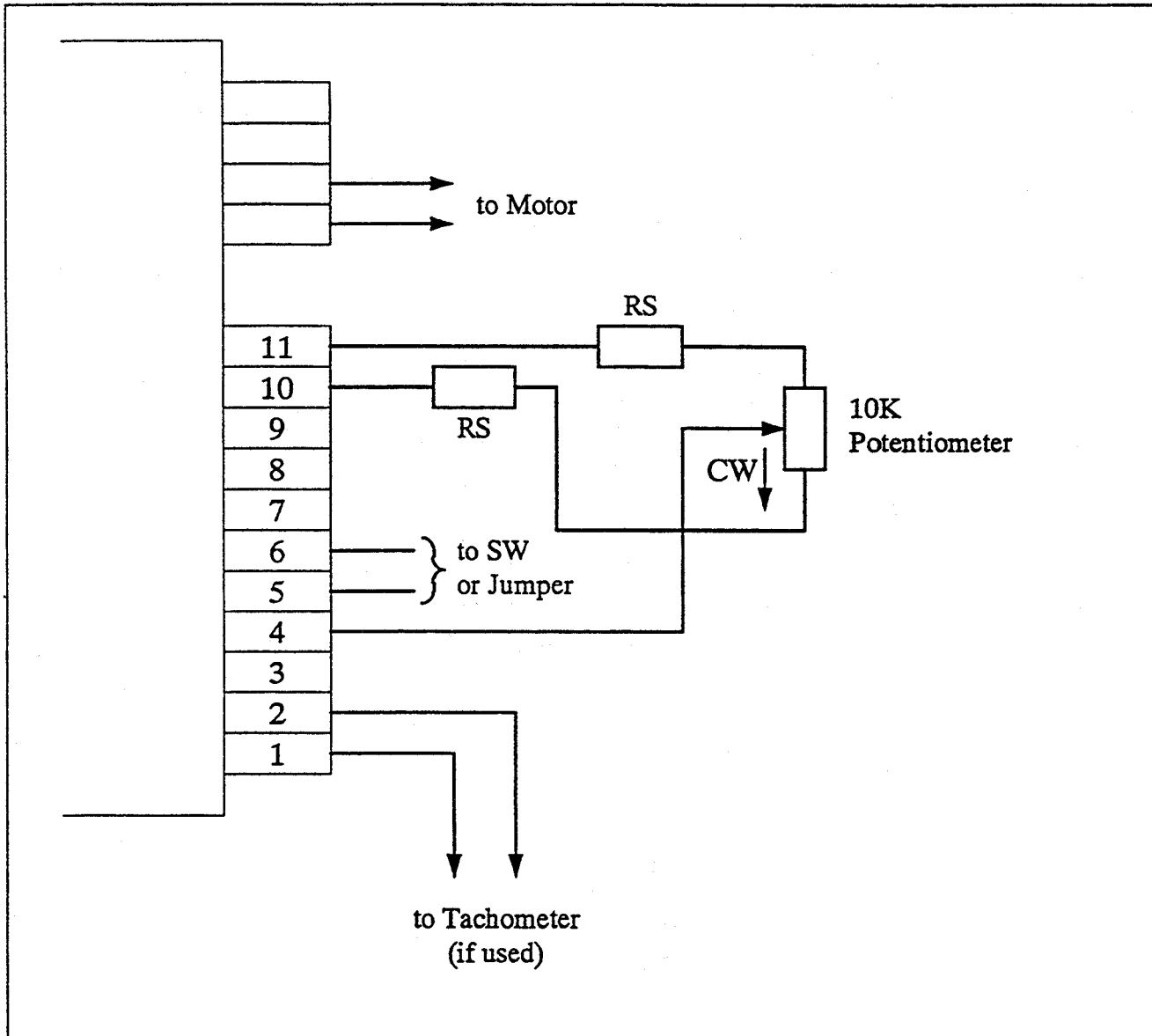
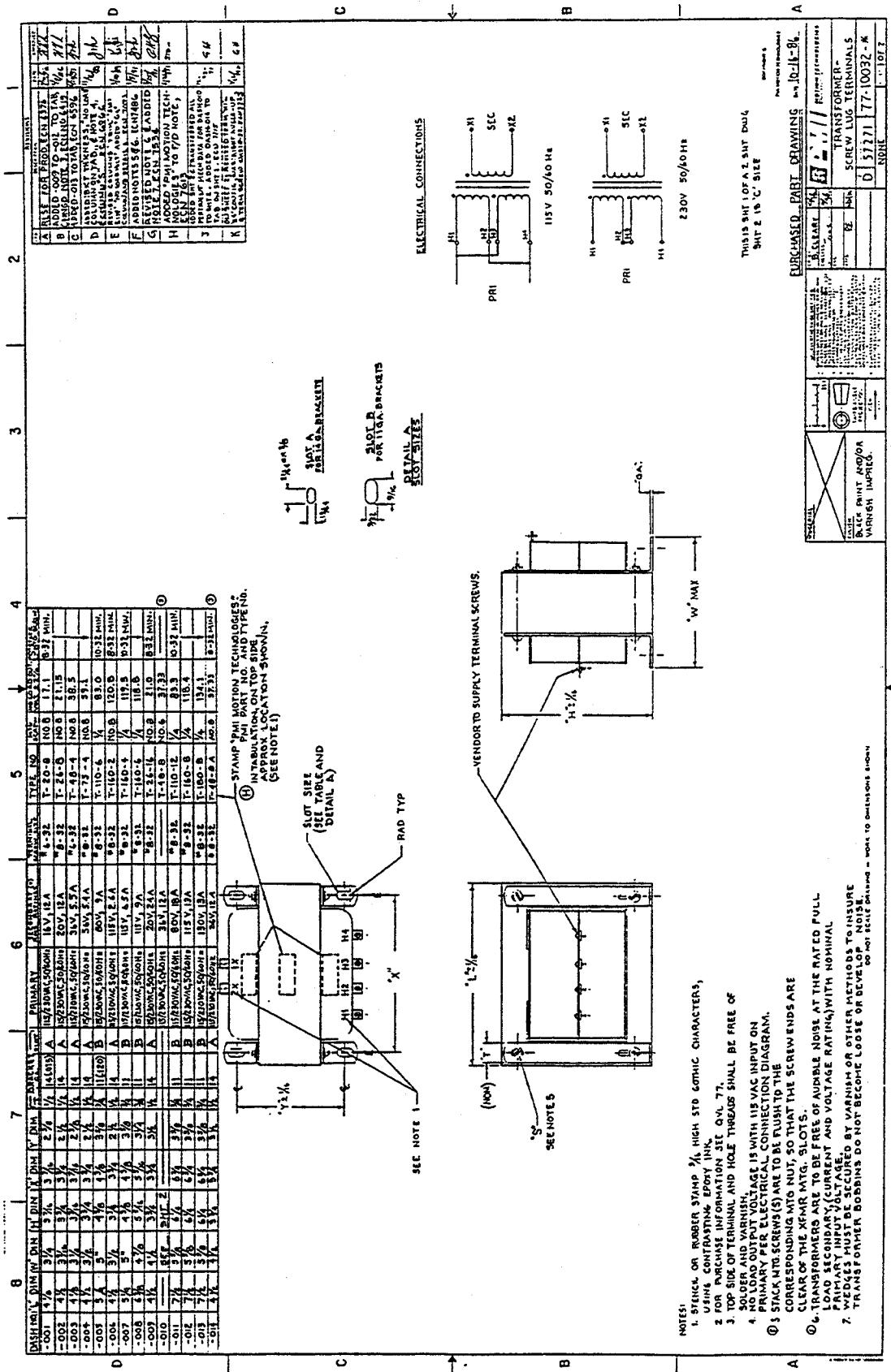

Figure 14. Schemes for Controlling Speed with a Potentiometer



- NOTES:
1. STENCIL OR RUBBER STAMP 3/16" HIGH STD GOTHIC CHARACTERS, USING CONTRASTING EPoxy INK.
 2. TOP SIDE OF TERMINALS AND HOLE THROUGHS SHALL BE FREE OF SOLDER AND VARNISH.
 3. PRIMARY AND SECONDARY WINDINGS SHALL BE FREE OF SOLDER AND VARNISH.
 4. NO LOAD OUTPUT VOLTAGE IS WITH 115V AC INPUT ON PRIMARY PER ELECTRICAL CONNECTION DIAGRAM.
 5. STACK INTO SCREWS (S) ARE TO BE FLUSH TO THE CORRESPONDING INTO NUT, SO THAT THE SCREW ENDS ARE CLEAR OF THE XPMR MFG. SLOTS.
 6. TRANSFORMERS ARE TO BE FREE OF AUDIBLE NOISE AT THE RATED FULL LOAD SECONDARY (CURRENT AND VOLTAGE RATING) WITH NOMINAL PRIMARY INPUT VOLTAGE.
 7. TRANSFORMER BOBBINGS DO NOT BECOME LOOSE OR DEVELOP NOISE WHEN HEATED BY VARNISH OR OTHER RESIDUES TO INSURE PROPER ELECTRICAL CONTACT.
 8. DO NOT SCALE DRAWING - WORK TO DIMENSIONS SHOWN.

