

**Installation Manual
for
KSM 100**

Series KSM131R



Installation Manual

Installation manual for extension module KSM 131R.

Note: The German version if the original version of the installation manual

Status: 09/2013

Valid from FW release 2.1.0.2

Subject to change without prior notification

The contents of this documentation has been collated with greatest care and corresponds with our present status of information. However, we would like to point out, that this document cannot always be updated at the same time as the technical further development of the products. Information and specifications can be changed at any time. Please keep yourself informed about the current version under www.kollmorgen.com.

Devices of the

Kollmorgen Europe GmbH
Pempelfurtstraße 1
DE-40880 Ratingen

Installation Manual

Table of Contents

1	IMPORTANT NOTES	4
1.1	Definitions	4
1.2	Co-valid Documents.....	4
1.3	Abbreviations Used	5
2	SAFETY REGULATIONS.....	6
2.1	Operation and Service	6
2.2	Transportation/Storage.....	6
3	DEVICE TYPES.....	7
3.1	Characteristic Data of Device.....	7
3.2	Identification	8
3.3	Scope of Delivery.....	8
4	CONNECTION AND INSTALLATION	9
4.1	General Notes on Installation	9
4.2	Installation and Assembly of the KSM Module	10
4.3	Installation of Backplane Bus System	10
4.4	Assembling the Modules	11
4.4.1	Assembly on C-rail.....	11
4.4.2	Assembly on Backplane Bus	12
4.5	Terminal Assignment.....	14
5	WIRING OF OUTPUTS.....	16
5.1	General Specifications for Wiring and Testing	16
5.1	Wiring of the Relay Outputs	17
5.1.1	Single-pole switching relay output without testing.....	17
5.1.2	Single-pole switching relay with external switching amplifier and testing	18
5.1.3	Dual-channel switching relay output with external monitoring group feedback	19
5.1.4	Two-channel relay output – external control circuit with monitoring.....	20
5.1.5	Dual-channel relay output with external control circuit in PL e.....	21
6	CONFIGURING THE KSM131R.....	22
6.1.1	Step 1	22
6.1.2	Step 2	23
6.1.3	Step 3	23
6.1.4	Step 4	24
7	MAINTENANCE	25
7.1	Modification / Handling Changes to the Device	25
7.2	Exchanging a Module.....	25
7.3	Maintenance Intervals.....	25
8	TECHNICAL DATA	26
8.1	Environmental Conditions	26
8.2	Load Carrying Capacity of Outputs.....	26
8.3	Technical Data of Switching Relay	26
8.4	Safety-Related Characteristic Data	27
8.4.1	Single-channel use of the relay output according to 5.1.2	27
8.4.2	Dual-channel use of the relay output according to 5.1.3	27

Installation Manual

1 Important Notes

Definition of individual target groups

Project engineers for secure drive systems:
Engineers and technicians

Assembly, electric installation, maintenance and replacement of devices:
Maintenance electricians and service technicians

Commissioning, operation and configuration:
Technicians and engineers

1.1 Definitions

The designation KSM100 is used as generic term for all derivatives from the KSM100 product range. Wherever this description refers to a certain derivative, the complete designation is used.

The term “safe” used in the following text in any case refers to the classification as a safe function for application up to PI e acc. to EN ISO 13849-1 or SIL3 acc. to EN 61508.

The system software “SafePLC” serves the purpose of configuring and programming KSM100 modules.

The modules of the KSM100 series are internally built up of two independent processing units. In the following these are referred to as system A and system B.

1.2 Co-valid Documents

Description	Reference
Installation Manual for Series KSM100	HB-37420-810-01-xxF-DE KSM100 Installation Manual
Acceptance test	TÜV certificate for product modules KSM131R

Note:

- Thoroughly read the manuals before you start the installation and the commissioning of the KSM100 module.
- Paying attention to the documentation is a prerequisite for trouble-free operation and fulfilment of possible warranty claims.

Installation Manual

1.3 Abbreviations Used

Abbreviation	Meaning
AC	Alternating voltage
IL	Instruction list
ELIA	Employer's liability insurance association
CLK	Clock (cycle)
CPU	Central Processing Unit
DC	Direct voltage
DI1..DI14	Digital Input
DIN	Deutsches Institut für Normung (German Institute for Standardization)
DO	Digital Output
EMU	Emergency Monitoring Unit
EMC	Electromagnetic compatibility
ELC	Emergency Limit Control
EN	European Standard
HISIDE	Output with 24VDC nominal level switching to plus
IP20	Degree of protection for housing
ISO	International Organisation for Standardisation
LED	Light Emitting Diode
LOSIDE	Output switching to reference potential
OLC	Operational Limit Control
PIA	Process image of outputs
PII	Process image of inputs
P1,P2	Pulse outputs
PLC	Programmable Logic Controller
POR	Power on Reset
PSC	Position Supervision Control
SELV	Safety Extra Low Voltage
SSI	Synchronous Serial Interface
VDE	Verband der Elektrotechnik, Elektronik und Informationstechnik e. V. (association for electrical engineering, electronics and information technology)

Installation Manual

2 Safety Regulations

Intended use

You can only operate the KSM131R module with an KSM100. This means that the same safety regulations apply as with the KSM100 module.

2.1 Operation and Service

The module must always be de-energized before installation and removal, or before disconnecting signal lines. For this purpose all live supply lines to the device must be checked for safe isolation from supply

When installing or removing the module appropriate measures must be applied to prevent electrostatic discharge to the externally arranged terminal and plug connections. Contact with such terminals should be reduced to a minimum and earthing by means of an earthing strap, for example, should be carried out before and during these procedures.

2.2 Transportation/Storage

Information concerning transport, storage and proper handling must be strictly followed. The climate related specifications in chapter "Technical data" must be complied with.

Installation Manual

3 Device Types

3.1 Characteristic Data of Device

Type Designation	Device Design
	<p>Design of module with the following periphery:</p> <ul style="list-style-type: none"> 12 Digital inputs (DI 1-4 and DI 8-12 OSSD) 2 I/Os optionally configurable as an input or output 4 Secure relay outputs 2 Pulse outputs 2 Signal outputs 12 Status LEDs for inputs 10 Status LEDs for I/O/relay output 1 Backplane bus interface

Installation Manual

3.2 Identification

The type plate is located on the left side wall of the module and contains the following information:

- Type designation
- Part number
- Serial number
- Identification of hardware release
- Identification of software release
- Safety category
- Input characteristics
- Output characteristics



Type plate KSM131R (image enlarged)

3.3 Scope of Delivery

The scope of delivery contains:

KSM131R module:

- A plug for all the signal terminals
- A backplane bus connector

Installation Manual

4 Connection and Installation

4.1 General Notes on Installation

Strictly follow the safety regulations when installing!

Type of protection IP20

Route all signal lines for the interfacing of digital inputs and contact monitoring separately.

In any case isolate 230VAC voltages from low voltage lines, if these voltages are used in connection with the application.

The cable lengths for digital inputs and outputs must not exceed **30m**.

Measures concerning the electromagnetic compatibility (EMC)

The KSM module is intended for use in the drive environment and meets the EMC-requirements mentioned above.

It is also assumed that the electromagnetic compatibility of the overall system is ensured by application of appropriate measures.

Use of the module as PESSRAL acc. to EN81:

When using the module as PESSRAL acc. to EN81 (elevator standard), the device must be installed at a minimum distance of 200mm to the transmitting facility with the following frequency ranges (mobile radio, etc.) 166-1000 MHz, 1710-1784 MHz, 1880-1960 MHz. The field strength of the transmitting facility must not exceed the following field strength values:

30V/m at 166-1000 and 1710-1784 MHz, 10V/m at 1880-1960 MHz.

Installation in a closed housing with degree of protection IP5X or better is additionally required.

Safety Note:

Electric power supply lines of the KSM and “discontinuous-action lines” of the power converter must be isolated from each other.

Signal lines and power lines of the power converter must be routed through separate cable ducts. The distance between the cable ducts should be minimum 10 mm.

Only shielded cables must be used to connect the position and speed sensors. The signal transmission cable must be RS-485-standard compliant (lines twisted in pairs).

Care must be taken to ensure that the shielding is correctly connected in the 9-pin SUB-D plugs of the position and speed sensors. Only metal or metal coated plugs are permitted.

The shielding on the sensor side must comply with appropriate methods.

EMC-compliant installation of the power converter technology in the environment of the KSM module must be assured. Special attention must be paid to the routing of cables, the shielding of motor cables and the connection of the braking resistor. Strict compliance with the installation instructions of the power converter manufacturer is mandatory.

All contactors in the environment of the power converter must be equipped with appropriate suppressor circuits.

Suitable measures to protect against overvoltages must be applied.

Installation Manual

4.2 Installation and Assembly of the KSM Module

The module is solely to be installed in control cabinets, with a degree of protection of at least IP54.

The modules must be vertically fastened on a top hat rail.

The ventilation slots must be kept unobstructed, to ensure adequate air circulation inside the module.

4.3 Installation of Backplane Bus System

The KSM131R module is connected to the KSM100 via the backplane bus.

Example: KSM100-1 + KSM131

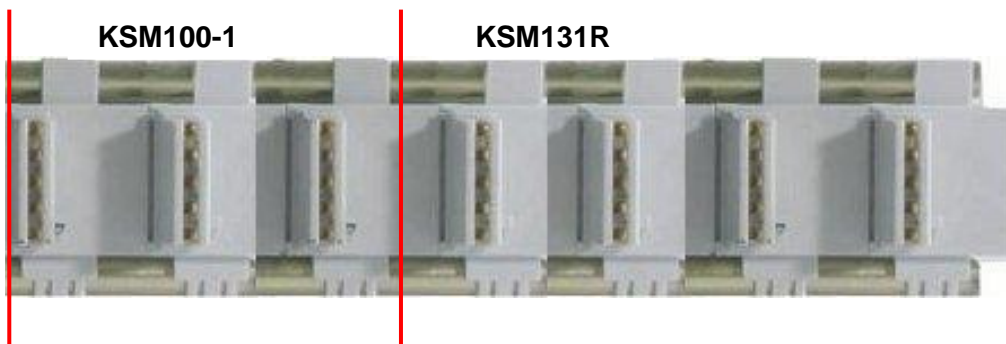

The KSM131R module is supplied with power via the backplane bus from the base unit. The digital outputs are supplied with power via plug connector X11 on the KSM131R module.

Note:

- A maximum of eight extension modules can be connected to one KSM100.
- You must not connect several KSM100 modules with extension modules to one backplane bus connection.

Installation Manual

4.4 Assembling the Modules

The modules are mounted on C-standard rails by means of snap-on latches.

4.4.1 Assembly on C-rail

The devices are inserted into the rail under an oblique angle and then snapped on downwards.

For disassembling use a screwdriver, insert it into the slot of the downwards pointing latch and then move it up.

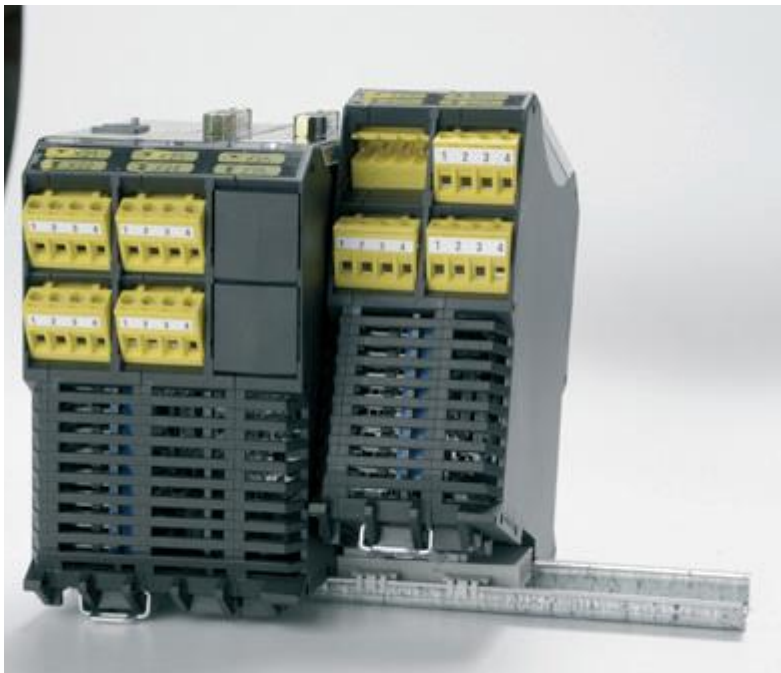

Installation Manual

4.4.2 Assembly on Backplane Bus

After assembling the backplane bus, you can install the device. For this purpose insert the module from above into the plug connection under a oblique angle and snap it onto the C-rail.



Insert the module from above under an oblique angle.



Snap-on downwards on to the C-rail.

Installation Manual

The backplane plug connection can later be extended. The system configuration can thus be extended by additional modules.



Snap the backplane bus element into the C-rail and insert it into the counter-piece by sliding it sideways.

Installation Manual

4.5 Terminal Assignment

Terminal	Designation	Function
X07:1	K1/11	Readback contact relay 1
X07:2	K1/12	Readback contact relay 1
X07:3	K2/11	Readback contact relay 2
X07:4	K2/12	Readback contact relay 2
X08:1	K3/11	Readback contact relay 3
X08:2	K3/12	Readback contact relay 3
X08:3	K4/11	Readback contact relay 4
X08:4	K4/12	Readback contact relay 4
X09:1	K5/11	Readback contact relay 5
X09:2	K5/12	Readback contact relay 5
X09:3	K6/11	Readback contact relay 6
X09:4	K6/12	Readback contact relay 6
X10:1	K7/11	Readback contact relay 7
X10:2	K7/12	Readback contact relay 7
X10:3	K8/11	Readback contact relay 8
X10:4	K8/12	Readback contact relay 8
X11:1	U24 external	IO voltage supply device +24 VDC
X11:2	U24 external	IO voltage supply device +24 VDC
X11:3	GND external	IO voltage supply device 0 VDC
X11:4	GND external	IO voltage supply device 0 VDC
X12:1	IO01	I/O extension 1 (EAEx.1 / EAAx.1)
X12:2	IO02	I/O extension 2 (EAEx.2 / EAAx.2)
X12:3	P1	Pulse output P1
X12:4	P2	Pulse output P2
X13:1		Not used
X13:2		Not used
X13:3	Ax.1	Semi-conductor output Ax.1 (not a safety output)
X13:4	Ax.2	Semi-conductor output Ax.2 (not a safety output)
X14:1	Digital IN01	Digital input 01 (Ex.1)
X14:2	Digital IN02	Digital input 02 (Ex.2)
X14:3	Digital IN03	Digital input 03 (Ex.3)
X14:4	Digital IN04	Digital input 04 (Ex.4)
X17:1	K1.1	Relay output 1
X17:2	K1.2	Relay output 1
X17:3	K2.1	Relay output 2
X17:4	K2.2	Relay output 2
X18:1	K3.1	Relay output 3
X18:2	K3.2	Relay output 3
X18:3	K4.1	Relay output 4
X18:4	K4.2	Relay output 4

X19:1	K5.1	Relay output 5
X19:2	K5.2	Relay output 5
X19:3	K6.1	Relay output 6
X19:4	K6.2	Relay output 6
X20:1	K7.1	Relay output 7
X20:2	K7.2	Relay output 7
X20:3	K8.1	Relay output 8
X20:4	K8.2	Relay output 8
X21:1		Not used
X21:2		Not used
X21:3		Not used
X21:4		Not used
X22:1		Not used
X22:2		Not used
X22:3		Not used
X22:4		Not used
X23:1	Digital IN05	Digital input 05 (Ex.5)
X23:2	Digital IN06	Digital input 06 (Ex.6)
X23:3	Digital IN07	Digital input 07 (Ex.7)
X23:4	Digital IN08	Digital input 08 (Ex.8)
X24:1	Digital IN09	Digital input 09 (Ex.9) (OSSD)
X24:2	Digital IN10	Digital input 10 (Ex.10) (OSSD)
X24:3	Digital IN11	Digital input 11 (Ex.11) (OSSD)
X24:4	Digital IN12	Digital input 12 (Ex.12) (OSSD)

Note)

- X: 1-> KSM131R device 1
- ...
- 8-> KSM131R device 8

Installation Manual

5 Wiring of Outputs

5.1 General Specifications for Wiring and Testing

The wiring suggestions below show both the options for functional use of the relay outputs and the wiring that is necessary for diagnostics in each case. Diagnosis must always be carried out in the case of any safety-relevant use of the relay outputs. Apart from the wiring, diagnostics requires integration into the application program of the monitoring function for secure outputs “EMU” – For more details on this topic, refer to the programming manual.

⚠ Safety Note:

- When using the relay outputs for safety-relevant functions, you must observe the information below, in particular the specifications on wiring diagnostics.
- The diagnostics for achieving the respective PI and SIL in accordance with the wiring suggestions below, require you to integrate an associated diagnostics function into the application program – For more details on this topic, refer to the programming manual.
- For applications with frequent safety shut-down requests, these tests should be performed more frequently, e.g. at the beginning of the shift, 1 x per week. However, a test should at least be carried out cyclically 1 x year.
- You must parameterize the HISIDE outputs of the KSM31R module as safety outputs (see configuration of KSM131R)

Wiring example relay with feedback:

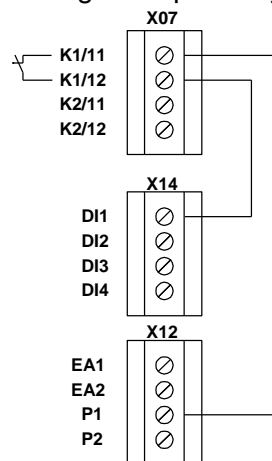

Fig.: Feedback of AK1

Installation Manual

5.1 Wiring of the Relay Outputs

5.1.1 Single-pole switching relay output without testing

For a single-pole connection without external testing, bear in mind that the KSM131R module will not recognize bonding of the internal relay or of one or more external contacts.

The following circuit example is only suitable for safety applications on a limited basis; at a maximum, PI b according to EN 13849-1 can be achieved!

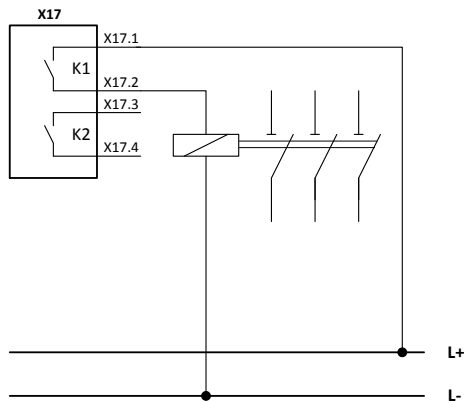

Fig.: Single-pole switching relay output.

Safety Note:

Not recommended for safety applications!

In this context see also the notes in EN 13849-1 concerning the application and the required fault exclusions.

Installation Manual

5.1.2 Single-pole switching relay with external switching amplifier and testing

If you are using only one relay output, you will need a set-up to test the complete chain, i.e. including all the downstream electro-mechanical, pneumatic or hydraulic components as well as a message/warning device if faults are detected to achieve PL c or above.

You need positively guided auxiliary contacts for downstream electro-mechanical devices or failsafe alarm contacts for the valve position for the hydraulic or pneumatic components. The message/warning device must ensure that the operator recognizes the dangerous situation immediately.

The achievable PI mainly depends on the test rate, PI d acc. to EM 13849-1 can be achieved at a maximum.

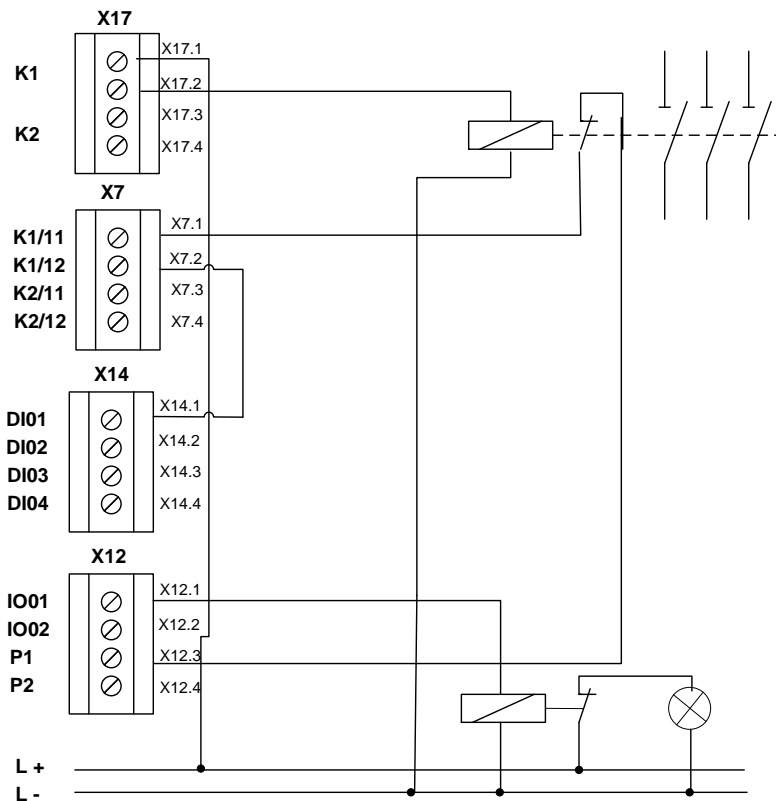

Fig.: Single-pole relay output with testing

⚠ Safety Note:

Only conditionally recommended for safety applications! In this context see also the notes in EN 13849-1 concerning the application and the required fault exclusions.

For PL c or above, a test rate > 100 * request rate is necessary. For PI d, you must carry out testing at least once a year.

For PL c and above, a message/warning feature is required that informs the operator immediately about a dangerous situation.

Installation Manual

5.1.3 Dual-channel switching relay output with external monitoring group feedback

For safety-related applications from PI d onwards according to EN ISO 13849-1, two relays on the KSM131R module and two external power contactors are used.

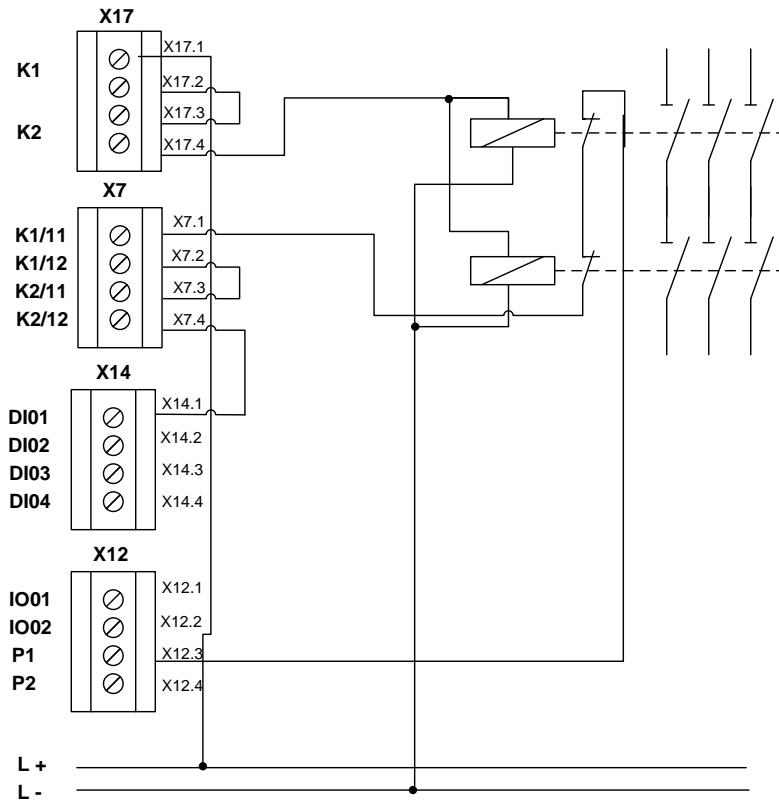

Fig.: Two-channel switching relay output with external monitoring – group feedback

The two external monitoring contacts are switched in series, supplied by clock signal P1 and read-in from DI01 (configured as an EMU input). In the case of higher requirements, you must consider that at least one switching process must take place every 24 hours.

⚠ Safety Note:

To achieve PI d or above according to EN ISO 13849-1, a sufficiently high testing rate is required.

For applications with frequent safety shut-down requests, these tests should be performed more frequently, e.g. at the beginning of the shift, 1 x per week. For PI d, you must carry out a cyclical test at least once a year; to achieve PI e this test is needed at least once per month.

Installation Manual

5.1.4 Two-channel relay output – external control circuit with monitoring

For safety applications from PI d and higher acc. to EN ISO 13849-1. The external circuit is controlled in dual-channel mode via two relay outputs. Each of the two external cutout paths is monitored. For PL e acc. to EN ISO 13849-1 a sufficiently high testing rate (see the remarks) and $MTTF_D = \text{high}$ is required for the external circuit.

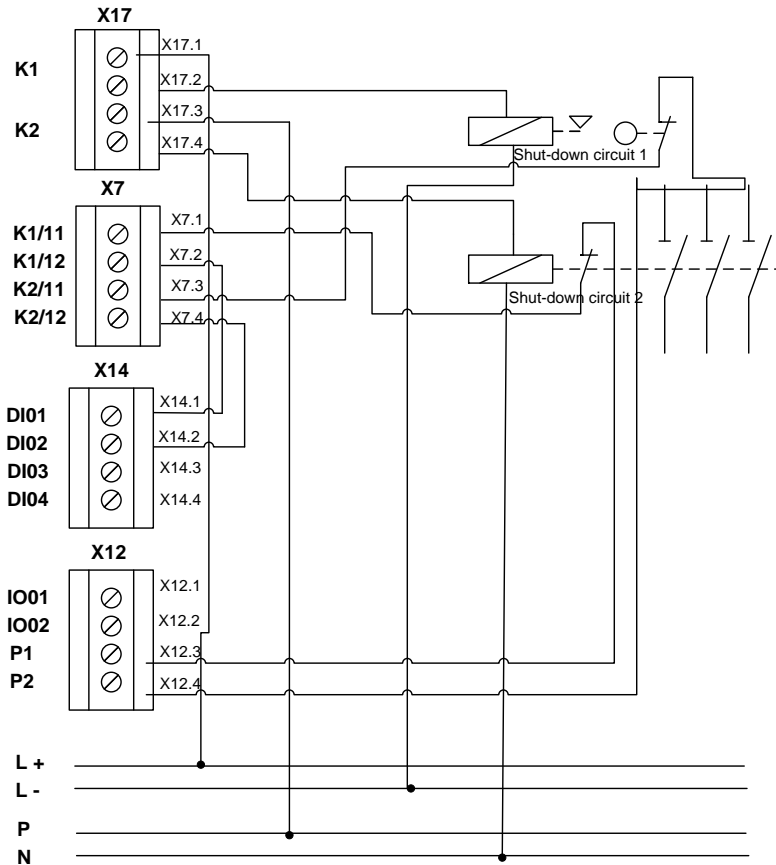

Safety Note:

To achieve PI d and above according to EN ISO 13849-1, a sufficiently high testing rate is required.

For applications with frequent safety shut-down requests, these tests should be performed more frequently, e.g. at the beginning of the shift, 1 x per week.

For PI d, you must carry out a cyclical test at least once a year; to achieve PI e this test is needed at least once per month.

Installation Manual

5.1.5 Dual-channel relay output with external control circuit in PL e

For safety applications from PL d and higher acc. to EN ISO 13849-1. The external circuit is controlled in dual-channel mode via the relay outputs. For PL e according to EN ISO 13849-1, a sufficiently high testing rate (see the remarks) is required as well as PL e for the external circuit.

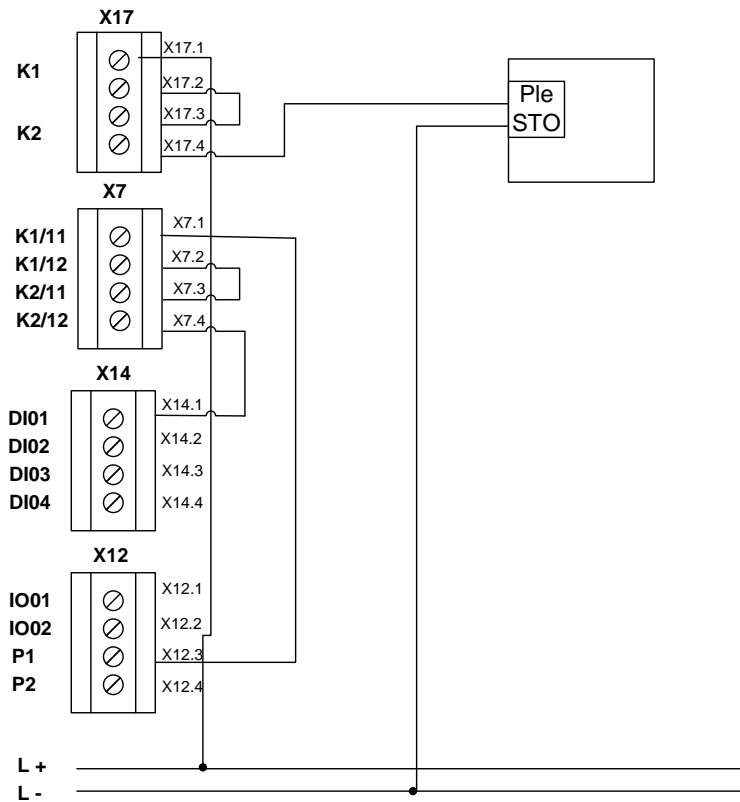

Safety Note:

For safety circuits, EN ISO 13849 yields the following requirements for the test interval:

- Cat3 / PL d: Testing once per year
- Cat 4 / PL e: Testing once per month.

Installation Manual

6 Configuring the KSM131R

6.1.1 Step 1

After starting the “SafePLC KSM100” program, you must first select the master module and then the I/O extension for the KSM131R.

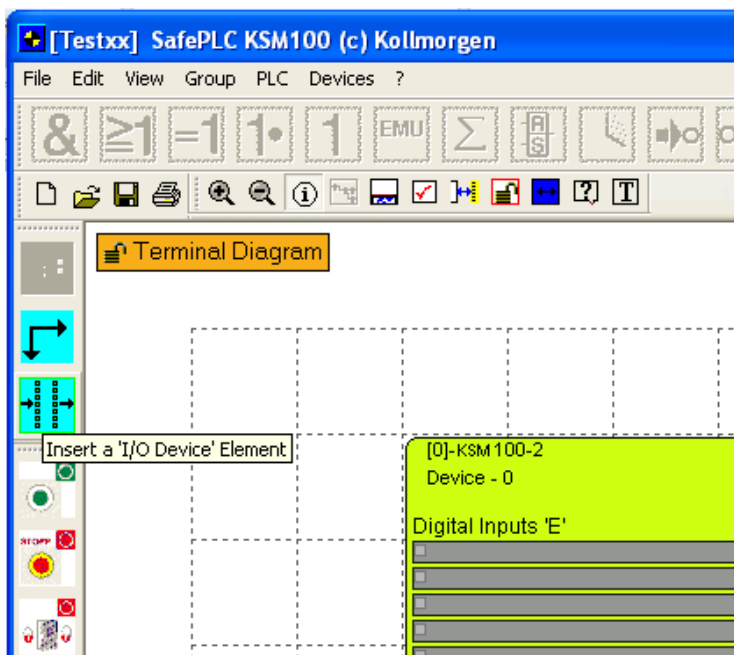
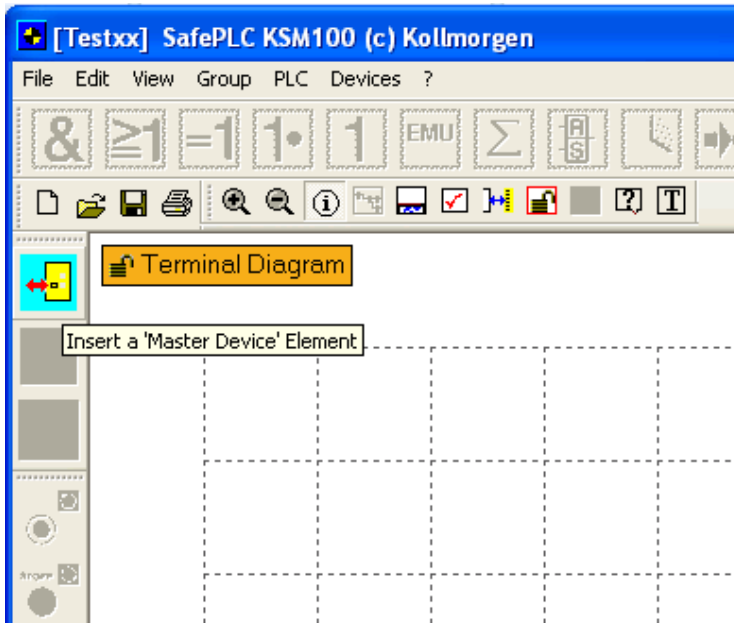

Installation Manual

6.1.2 Step 2

On the KSM131R module, you must set the bus address using the address switch.

This setting is made on the back of the module

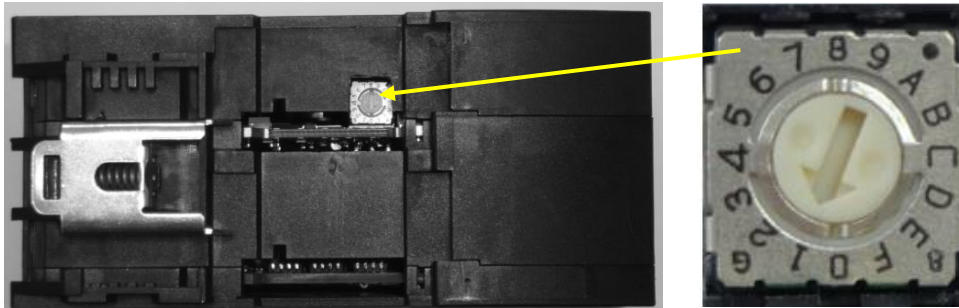

Note:

- The address range of the KSM131R module is from 1...15.
- Address “0” is reserved for the basic device.

6.1.3 Step 3

In the main menu of the “Safe PLC KSM100” program, you can open the configuration dialog for the KSM131R module by double-clicking on the KSM131R extension module.

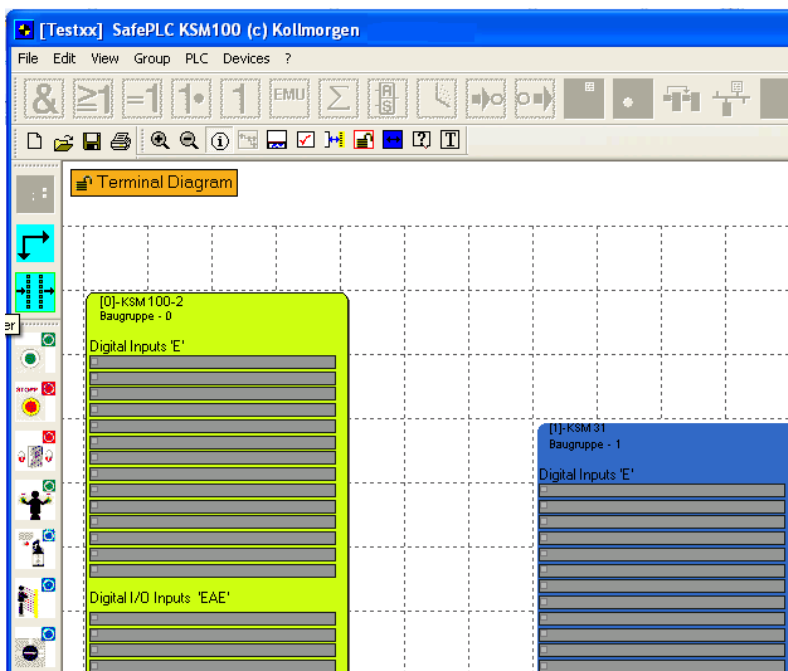

Installation Manual

6.1.4 Step 4

The following settings must be made in the KSM131R configuration dialog:

- Logical address of KSM131R device x: Setting the address switch of the KSM131R module.
- Group1 EAAx.1-EAAx.6 or group1 EAAx.7-EAAx.10: When using these outputs one can choose between safety and standard outputs.

Attention:

You should always configure group EAAx.1-EAAx.6 or group 1 EAAx.7-EAAx.10 as safety outputs to be able to use them in a safety application.

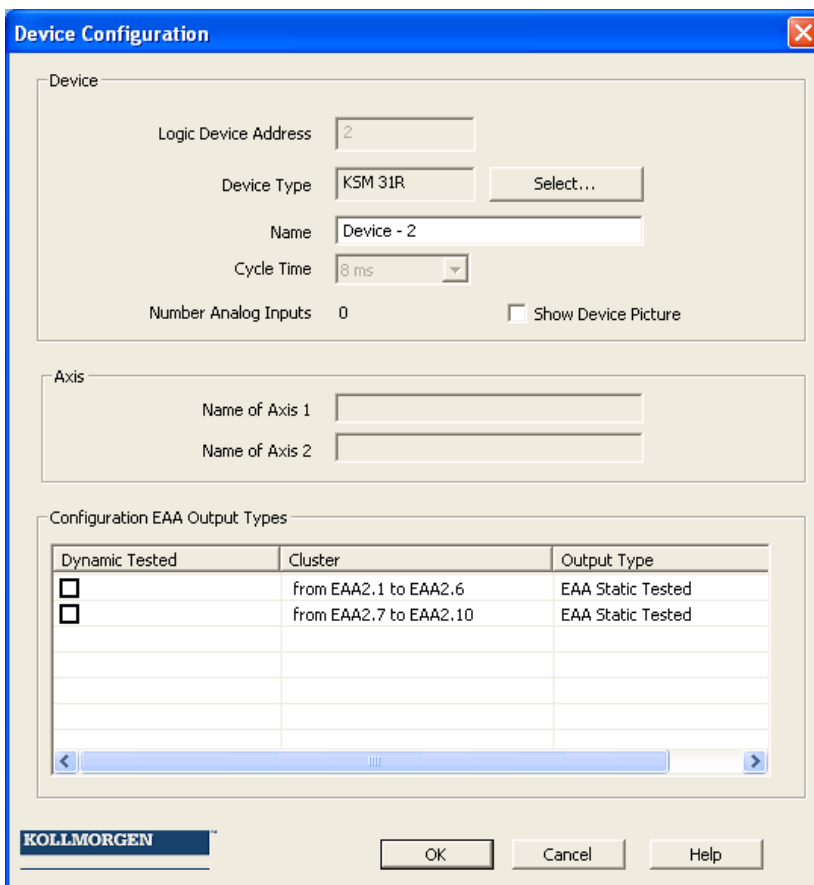

Dynamic Tested	Cluster	Output Type
<input type="checkbox"/>	from EAA2.1 to EAA2.6	EAA Static Tested
<input type="checkbox"/>	from EAA2.7 to EAA2.10	EAA Static Tested

Installation Manual

7 Maintenance

7.1 Modification / Handling Changes to the Device

Repair

Repair work on the device can only be performed in the factory.

Warranty

By opening the module without permission the warranty will become null and void.

Note: By modifying the module the safety approval will become null and void!

7.2 Exchanging a Module

When replacing an KSM131R module, you must observe the following points:

- Switch off the electric power supply for all the KSM modules and disconnect them.
- Remove all the plug-in connections of the KSM131R module.
- Take the module off the top hat rail, make a note of the bus address and pack it in an EMC-compliant way.
- Set the bus address of the new module using the address switch and mount it on the top hat rail.
- Reconnect all connections.
- Switch on the electric power converter.
- Switch on the supply voltage.

Note: Pluggable connections of the KSM100 module must generally not be disconnected or connected in live condition.

7.3 Maintenance Intervals

Module replacement	See technical data
Function test	See chapter "Start-up"

Installation Manual

8 Technical Data

8.1 Environmental Conditions

Class of protection	IP 20
Ambient temperature	0°C* ... 50°C
Climatic category	3 acc. to DIN 50 178
Lifetime	90000h at 50°C ambient

8.2 Load Carrying Capacity of Outputs

The outputs can be loaded as follows:

Output	Voltage	Current
Ax.1, Ax.2	24 VDC	100 mA
EAAx.1-2)	24 VDC	250 mA
K1-K8	24 VDC	2 A
	48 VDC	2 A
	230 VAC/2A	2 A

Note:*) See the KSM100 installation manual

8.3 Technical Data of Switching Relay

Switching capacity min./max.	3 / 2000 (1 mVA / 7 VA)
Switching performance According to IEC/EN 60947-5-1 AC 15 According to IEC/EN 60947-5-1 DC 13 At 0.1 Hz DC 13	250V / 3A 24 V / 1 A 24 V / 4 A
Electrical service life	➤ 50,000 switching cycles
Switching frequency	20 switching cycles / s
Mechanical service life	> 40 x 10 ⁶ switching cycles

Installation Manual

8.4 Safety-Related Characteristic Data

8.4.1 Single-channel use of the relay output according to 5.1.2

Max. achievable safety class	<ul style="list-style-type: none"> • SIL 2 acc. to EN61508 • Performance level d according to EN ISO 13849-1
System structure	<ul style="list-style-type: none"> • 1-channel with diagnose (1001) • Category 2 acc. to EN13849-1
Rating of operating mode	“high demand” acc. to EN 61508 (high demand rate)
Probability of an endangering failure per hour (PFH-value)	< 2.6 E-8 (26 FIT) / per single-channel output used
Proof test interval (EN61508)	20 years; after this time, the module must be replaced

8.4.2 Dual-channel use of the relay output according to 5.1.3

Max. achievable safety class	<ul style="list-style-type: none"> • SIL 3 acc. to EN61508 • Performance level e acc. to EN ISO 13849-1
System structure	<ul style="list-style-type: none"> • 2-channel with diagnose (1002) • Category 4 acc. to EN13849-1
Rating of operating mode	“high demand” acc. to EN 61508 (high demand rate)
Probability of an endangering failure per hour (PFH value)	< 2.46 E-9 (2.5 FIT) / per dual-channel output used
Proof test interval (EN61508)	20 years; after this time, the module must be replaced

About Kollmorgen

Kollmorgen is a leading provider of motion systems and components for machine builders. Through world-class knowledge in motion, industry-leading quality and deep expertise in linking and integrating standard and custom products, Kollmorgen delivers breakthrough solutions that are unmatched in performance, reliability and ease-of-use, giving machine builders an irrefutable marketplace advantage.

For assistance with your application needs, visit www.kollmorgen.com or contact us at:

North America

Kollmorgen

203A West Rock Road
Radford, VA 24141 USA

Web: www.kollmorgen.com

Mail: support@kollmorgen.com

Phone: 1-540-633-3545

Fax: 1-540-639-4162

Europe

Kollmorgen

Pempelfurtstraße 1
40880 Ratingen, Germany

Web: www.kollmorgen.com

Mail: technik@kollmorgen.com

Phone: + 49-2102-9394-0

Fax: + 49 -2102-9394-3155

Asia

Kollmorgen

Rm 2205, Scitech Tower, China
22 Jianguomen Wai Street

Web: www.kollmorgen.com

Mail: sales.asia@kollmorgen.com

Phone: + 86-400-666-1802

Fax: +86-10-6515-0263