

Product KSM 100-2-CN

Measurements in mm (h.x.d.x.w): 100x115x135

Description

Open programmable safe PLC for machinery and plant construction. The modules can be enhanced up to 130 safe I/O's and / or up to 12 axes.
The basic module KSM100-2-CN supplies 20 safe I/O's, 14 safe inputs and 3 safe cut off channels as well as a memory card slot for easy program and configuration change. option: fieldbus interface can be integrated.

The continuous function chart oriented programming frame SafePLC allows an easy and comfortable implementation of safety related tasks. The firmware of modules offers an comprehensive library for standard functions for safe signal preprocessing of safety related sensors and actors as well as for practical technology functions especially for safe motion of drives.

The spectrum of the modules reaches from conventional safe logic processing through simple safe speed monitoring tasks of single axes up to complex safe more dimensional speed- and range / zone monitoring in multiple axes processing.

The CANopen communication device used to exchange non safe data between KSM modular device and non-safe control systems. The configuration of the non-safe data via SafePLC of modular device. The device must be parameterized as a CANopen slave device.

- 20 safe I/O's configurable as input or output, 14 safe inputs, 3 cut off channels, thereof 1 safe relay output and 2 messaging outputs in the basic module
- Expandable up to 130 safe I/O's, and / or 12 safe axes via backplane bus (connectors to snap on head rail)
- Integrated fieldbus interface (CANopen)
- CFC oriented programming with SafePLC - Software
- Comprehensive library with pre-configured safety related sensors and actors
- Complete speed- ad position-oriented safety functions for safe motion according to EN 61800-5-2
- Dimensional functions for safe speed- and range / zone monitoring possible
- Parameter administration for expansion modules in the basic module
- Cross circuit monitoring
- Comprehensive diagnostics integrated in firmware
- Coded status display using a 7-segment display and LED's mounted in the front side
- Quit-/Start-/Reset- button in front side

Pin Out - terminal diagram

X 41	1 - U24 external 2 - U24 external 3 - GND external 4 - GND external	powersupply module +24 Volts powersupply module +24 Volts powersupply module 0 VDC powersupply module 0 VDC
X 42	1 - DI 13 2 - DI 14 3 - P1 4 - P2	digital IN 13 digital IN 14 pulse output P1 pulse output P2
X 43	1 - DO 0 - HI 2 - DO 0 - LO 3 - DO 1 - HI 4 - DO 1 - LO	HISIDE-output 0 LOSIDE-output 0 HISIDE-output 1 LOSIDE-output 1
X 44	1 - K1.1 2 - K1.2 3 - K2.1 4 - K2.2	relay output 1 relay output 2
X 45	1 - U24 external 2 - U24 external 3 - GND external 4 - GND external	powersupply module +24 Volts powersupply module +24 Volts powersupply module 0 VDC powersupply module 0 VDC
X 46	1 - IO 1 2 - IO 2 3 - DO 03 4 - DO 04	digital I/O 1 digital I/O 2 messaging and auxiliary output 3 messaging and auxiliary output 4
X 47	1 - IO 03 2 - IO 04 1 - IO 05 2 - IO 06	digital I/O 3 digital I/O 4 digital I/O 5 digital I/O 6
X 48	1 - IO 07 2 - IO 08 1 - IO 09 2 - IO 10	digital I/O 7 digital I/O 8 digital I/O 9 digital I/O 10
X 49	1 - U24 external 2 - U24 external 3 - GND external 4 - GND external	powersupply module +24 Volts powersupply module +24 Volts powersupply module 0 VDC powersupply module 0 VDC
X 50	1 - IO 11 2 - IO 12 3 - DO 05 4 - DO 06	digital I/O 11 digital I/O 12 messaging and auxiliary output 5 messaging and auxiliary output 6
X 51	1 - IO 13 2 - IO 14 1 - IO 15 2 - IO 16	digital I/O 13 digital I/O 14 digital I/O 15 digital I/O 16
X 52	1 - IO 17 2 - IO 18 1 - IO 19 2 - IO 20	digital I/O 17 digital I/O 18 digital I/O 19 digital I/O 20
X 61	1 - U24 external 2 - U24 external 3 - U24 external 4 - U24 external	powersupply module +24 Volts powersupply module +24 Volts powersupply module 0 VDC powersupply module 0 VDC
X 62	1 - NC 2 - NC 3 - NC 4 - NC	NC NC NC NC
X 63	1 - NC 2 - NC 3 - NC 4 - NC	NC NC NC NC
X 64	1 - NC 2 - NC 3 - NC 4 - NC	NC NC NC NC
X 65	1 - NC 2 - NC 3 - DO 0.1 4 - DO 0.2	NC NC messaging and auxiliary output 1 messaging and auxiliary output 2
X 66	1 - DI01 2 - DI02 3 - DI03 4 - DI04	digital IN 01 OSSD compatible digital IN 02 OSSD compatible digital IN 03 OSSD compatible digital IN 04 OSSD compatible
X 67	1 - DI05 2 - DI06 3 - DI07 4 - DI08	digital IN 05 digital IN 06 digital IN 07 digital IN 08
X 68	1 - DI09 2 - DI10 3 - DI11 4 - DI12	digital IN 09 OSSD compatible digital IN 10 OSSD compatible digital IN 11 OSSD compatible digital IN 12 OSSD compatible

Technical data

Safety characteristics	PI in accordance to EN 13849 PFH/Architecture SIL in accordance to EN 61508 Proof-test-interval	PI e Typ. 6,0 * 10 ⁻⁹ /Architecture Class 4 SIL 3 20 years = max. period of application
General data	Max. number of extension modules Interface for extension modules Safe digital input lines Safe digital I/O lines Safe digital output lines Safe analog-In Safe relay outputs Standard output lines Pulse output lines (cross-short-cut detection) Type of connectors	6 T-bus-connector (compact assembly) / KSM 51 bus extension module (decentralize assembly) 14 incl. 8 OSSD 20 2 - 1 6 2 Pluggable terminals
Data Interface	CANopen	Baudrate 500kBit/s
Electrical data	Supply voltage Tolerance Power consumption Rated data digital In Rated data digital Out Rated data relay output Pulse output lines (cross-short-cut detction) Max. fuse on supply voltage	24 VDC/2A -15%, +20% Max. 3,2 W 24 VDC; 20 mA, Typ1 in accordance to EN61131-2 24 VDC; 250 mA 24 VDC/2A and 230 VAC/2A Max. 250 mA Max. 2 A
Environmental data	Temperature Protection rating Climate class EMI	0° up to 50° operational temp.; -10° up to +70° storage temp. IP 52 3 in accordance to DIN 50 178 According to EN 55011 and EN 61000-6-2
Mechanical data	Size (h.d.w [mm]) Weight Mounting Max. terminal cross-section	100x115x135 800 g Snap-on mounting on standard head rail 1,5 mm²

KSM 100-2-CN - I/O overview

Quantity	I/O s
14	digital inputs
20	digital inputs/outputs
2	pulse outputs
2	digital outputs relays
2	digital outputs LOSIDE
2	digital outputs HISIDE
6	messaging outputs
1	memory card
1	CANopen

KSM 100-2-CN - sketch (example)

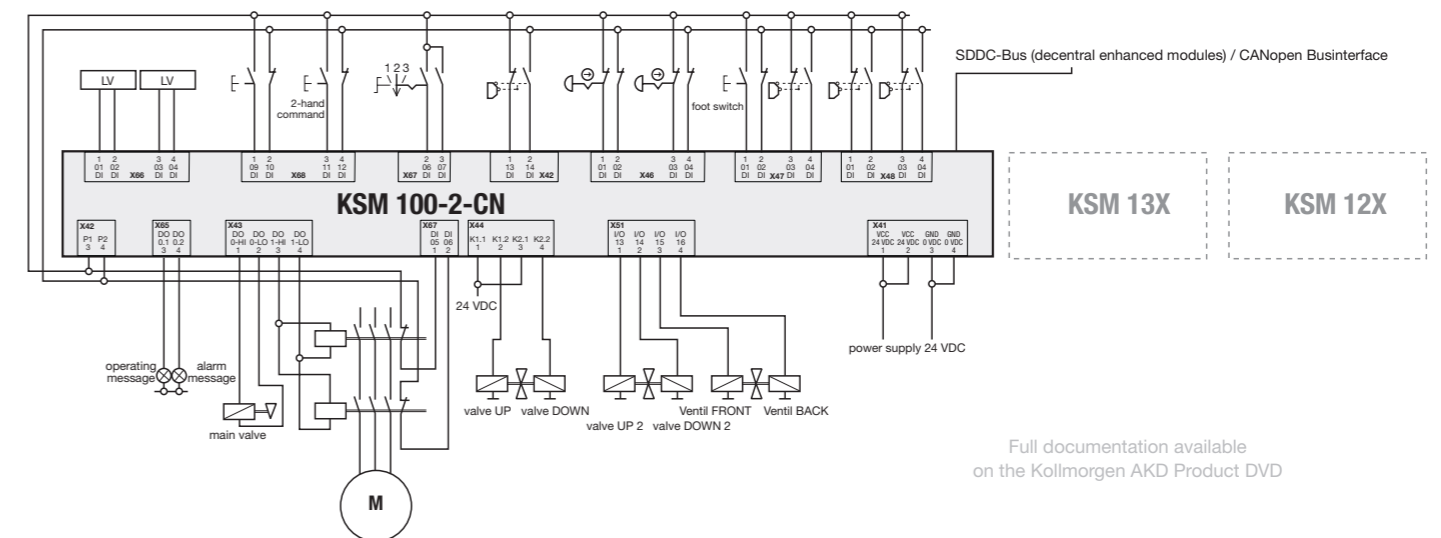

Full documentation available on the Kollmorgen AKD Product DVD