

Graphic Operator Terminal Installation Manual



Revision 1.1, August 2011

AKI-CDF-MOD-10T 10.4" Keypad HMI



Keep all manuals as a product component during the life span of the product.
Pass all manuals to future users / owners of the product.

KOLLMORGEN[®]

Because Motion Matters™

Record of Document Revisions

Revision	Remarks
1.0	Preliminary edition
1.1	Added mechanical drawings to Appendix A. For more information, see "Appendix A" page 27.

IMPORTANT NOTICE

Copyright© Kollmorgen™2010-2011. All rights reserved. Kollmorgen holds the copyright to this manual. All rights are reserved and no part of this publication may be reproduced or transmitted in any form or by any means without prior written consent from Kollmorgen.

Disclaimer

The information in this manual was accurate and reliable at the time of its release. However, Kollmorgen. reserves the right to change the specifications of the product described in this manual without notice at any time.

This document contains proprietary and confidential information of Kollmorgen. The contents of the document may not be disclosed to third parties, translated, copied or duplicated in any form, in whole or in part, without the express written permission of Kollmorgen.

Registered Trademarks

Kollmorgen is a registered trademark of Danaher Corp.

Technical changes which improve the performance of the device may be made without prior notice! Printed in the Federal Republic of Germany. All rights reserved. No part of this work may be reproduced in any form (by printing, photocopying, microfilm or any other method) or stored, processed, copied or distributed by electronic means without the written permission of Kollmorgen. All other proprietary names mentioned in this manual are the trademarks of their respective owners.

August 2011

1	Considerations and Safety Precautions	
1.1	Important Considerations	5
1.2	UL and cUL Installation	5
1.3	General	5
1.4	During Installation	6
1.5	During Use	6
1.6	Service and Maintenance	7
1.7	Dismantling and Scrapping	7
2	Installation	
2.1	Space Requirements	8
2.2	Installation Process	8
2.2.1	Mode Switches	10
2.2.2	Connections to the Controller	11
2.2.3	Other Connections and Peripherals	11
3	Technical Specifications	
3.1	Technical Data	12
4	Chemical Resistance	
4.1	Metal Casing	14
4.2	Key Panel and Overlay	15
4.3	Autotex F157/F207	15
4.4	Key Panel Surface	16
4.5	Key Panel Protector	16
5	Operator Terminal Diagrams	
5.1	Communication Port Diagrams	17
5.2	Outline Diagrams	18
5.3	Text Strip Diagram	19
6	Installation Tips	
6.1	Grounding the Operator Terminal	20
6.2	Ethernet Connection in the Terminal	21
6.3	Achieving EMC Protection	22
6.4	Ambient Temperature	23
6.5	Safety	24
6.6	Galvanic Isolation	25
6.7	Cable and Bus Termination RS485	26
	Appendix A	
A.1	AKI-CDF-MOD-10T 10.4" – Front View 1	27
A.2	AKI-CDF-MOD-10T 10.4" – Front View 2	27
A.3	AKI-CDF-MOD-10T 10.4" – Bottom View	28
A.4	AKI-CDF-MOD-10T 10.4" – Side View	28

A.5 AKI-CDF-MOD-10T 10.4" – Back View.....29

1 CONSIDERATIONS AND SAFETY PRECAUTIONS

Both the installer and the owner or operator of the graphic operator terminal must read and understand this installation manual.

1.1 Important Considerations

The scope of this manual is the hardware installation of your new device. Please be advised that software is required to create custom applications for your hardware. For User Interface (UI) applications, Kollmorgen strongly recommends the Kollmorgen Visualization Builder software (KVB).

The Kollmorgen Visualization Builder software is used to configure Human Machine Interface (HMI) panels and PC operated control applications, including applications for Programmable Automation Controllers (PAC) from Kollmorgen.

The Kollmorgen Visualization Builder makes it easy to create logical, flexible and effective HMI/PAC applications that provide the right information on the right occasion to operators and to other systems.

For more information, refer to the Kollmorgen Visualization Builder User Manual and Quick Start Guide.

1.2 UL and cUL Installation

- This equipment is suitable for use in Class I, Division 2, Groups A, B, C and D or non-hazardous locations only.
- Maximum ambient temperature 40 °C when mounted horizontal or 50 °C when mounted vertical.
- **WARNING! EXPLOSION HAZARD!** – Do not disconnect equipment unless power is removed or the area is known to be non-hazardous.
- **WARNING! EXPLOSION HAZARD!** – Substitution of components may impair suitability for Class I, Division 2.
- **WARNING! EXPLOSION HAZARD!** – Only UL and cUL approved expansion units are allowed to be connected to the port designated as Expansion. At the moment there are no such units evaluated or allowed.
- **WARNING! EXPLOSION HAZARD!** – Do not replace expansion unit unless power is switched off or the area is known to be non-hazardous.
- This product contains a battery and must only be changed in an area known to be non-hazardous. Permitted types are shown in the section Technical Specifications.
- For use on a flat surface of a type 4X enclosure indoor use only.
- To make wiring connections to the power supply connector, use a AWG 28-12 cable and tighten to a minimum of 0.5 Nm.

1.3 General

- Read the safety precautions carefully.

- Check the delivery for transportation damage. If damage is found, notify the supplier as soon as possible.
- Do not use the graphic operator terminal in an environment with high explosive hazards.
- The supplier is not responsible for modified, altered or reconstructed equipment.
- Use only parts and accessories manufactured according to specifications of the supplier.
- Read the installation and operating instructions carefully before installing, using or repairing the graphic operator terminal.
- Never allow fluids, metal filings or wiring debris to enter any openings in the graphic operator terminal. This may cause fire or electrical shock.
- Only qualified personnel may operate the graphic operator terminal.
- Storing the graphic operator terminal where the temperature is lower or higher than recommended in this manual can cause the LCD display liquid to congeal and become isotopic.
- The LCD display liquid contains a powerful irritant. In case of skin contact, wash immediately with plenty of water. In case of eye contact, hold the eye open, flush with plenty of water and obtain medical attention.
- The figures in this manual serve an illustrative purpose. Because of the many variables associated with any particular installation, the supplier cannot assume responsibility for actual use based on the figures.
- The supplier neither guarantees that the graphic operator terminal is suitable for your particular application, nor assumes responsibility for your product design, installation or operation.

1.4 During Installation

- The graphic operator terminal is designed for stationary installation on a plane surface, where the following conditions are fulfilled:
 - no high explosive risks
 - no strong magnetic fields
 - no direct sunlight
 - no large, sudden temperature changes
- Install the product according to the accompanying installation instructions.
- Ground the product according to the accompanying installation instructions.
- Only qualified personnel may install the graphic operator terminal.
- Separate the high voltage, signal and supply cables.
- Make sure that the voltage and polarity of the power source is correct before connecting the product to the power outlet.
- Peripheral equipment must be appropriate for the application and location.

1.5 During Use

- Keep the graphic operator terminal clean.

- Emergency stop and other safety functions may not be controlled from the graphic operator terminal.
- Do not use too much force or sharp objects when touching the key panel etc.

1.6 Service and Maintenance

- Only qualified personnel should carry out repairs.
- The agreed warranty applies.
- Before carrying out any cleaning or maintenance operations, disconnect the equipment from the electrical supply.
- Clean the display and surrounding front cover with a soft cloth and mild detergent.
- Replacing the battery incorrectly may result in explosion. Only use batteries recommended by the supplier

1.7 Dismantling and Scrapping

- The graphic operator terminal or parts thereof shall be recycled according to local regulations.
- The following components contain substances that might be hazardous to health and the environment: lithium battery, electrolytic capacitor and display.

2 INSTALLATION

This section provides installation information for the graphic operator terminal.

2.1 Space Requirements

- Installation plate thickness: 1.5 – 9.0 mm (0.06 - 0.35 inch)
- Space requirements when installing the graphic operator terminal:

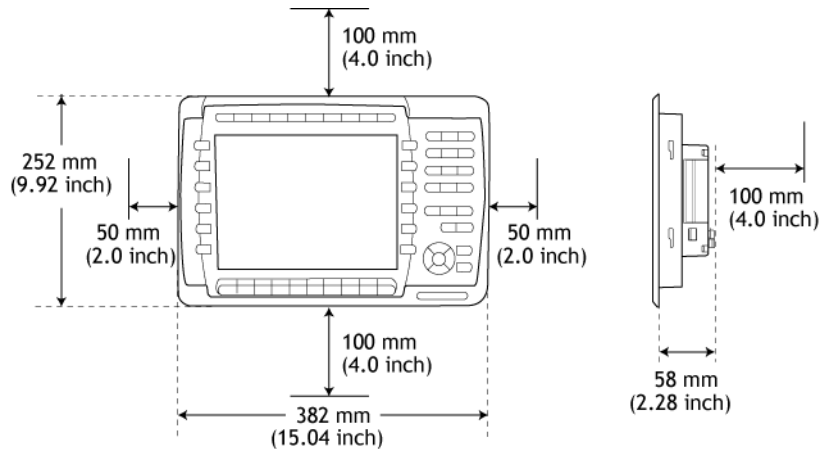

CAUTION! The openings on the enclosure are for air convection. Do not cover these openings!

2.2 Installation Process

1. Unpack and check the delivery. If damage is found, contact Kollmorgen.

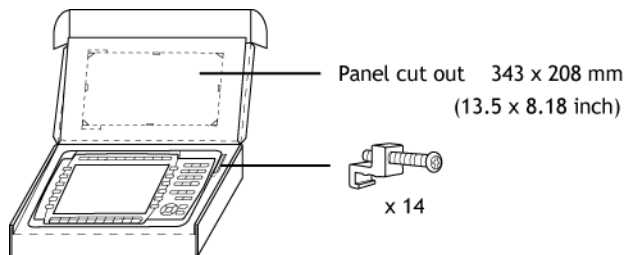

WARNING! Place the graphic operator terminal on a stable surface during installation. Dropping it or letting the terminal fall may cause damage.

2. Place the panel cut out where the graphic operator terminal is to be situated, draw along the outer sides of the holes and cut according to the markings.

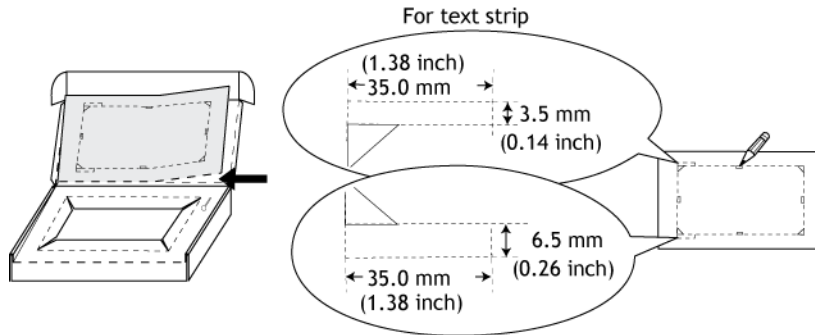

3. Secure the graphic operator terminal in position using all the fastening holes and the provided brackets and screws:

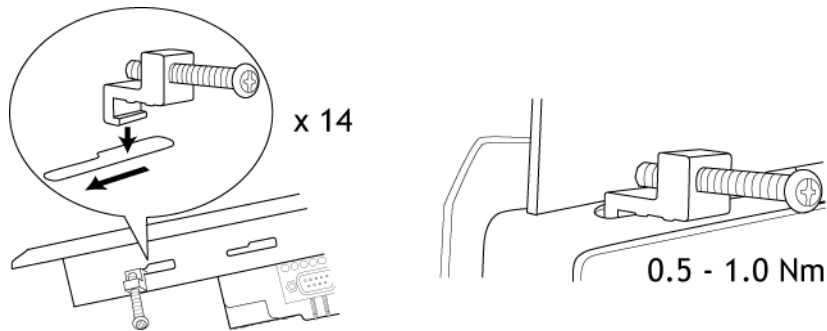

4. Connect the cables in the specified order.
 - A. **CAUTION!** Ensure that the graphic operator terminal and the controller system have the same electrical grounding (reference voltage level), otherwise errors in communication may occur.
 - B. Use an M5 screw and a grounding conductor (as short as possible) with a cross-section of minimum 2.5 mm².
 - C. **CAUTION!** Use only shielded communication cables. Separate high voltage cables from signal and supply cables.
 - D. **CAUTION!** The graphic operator terminal must be brought to ambient temperature before it is started. If condensation forms, ensure that the graphic operator terminal is dry before connecting it to the power outlet. Ensure that the voltage and polarity of the power source is correct.

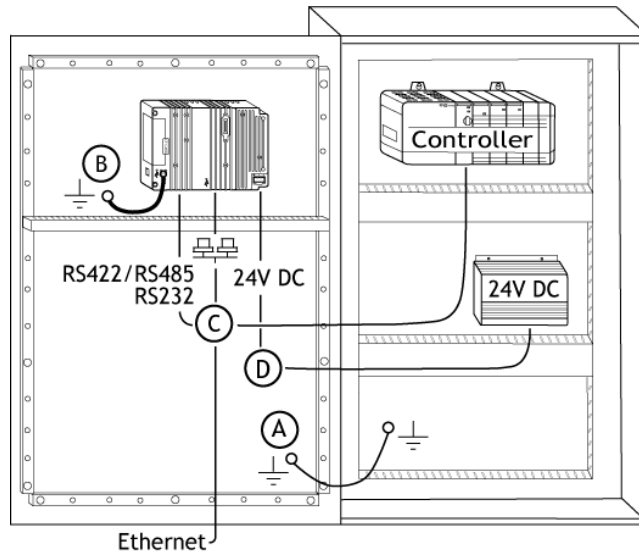

5. Carefully remove the laminated film over the graphic operator terminal display to avoid static electricity that could damage the terminal.

2.2.1 Mode Switches

The HMI panels have four mode switches (DIP switches) located on the rear side of the operator terminal.

All mode switches must be in OFF position during graphic operator terminal use. The mode switches should not be touched unless by qualified personnel.

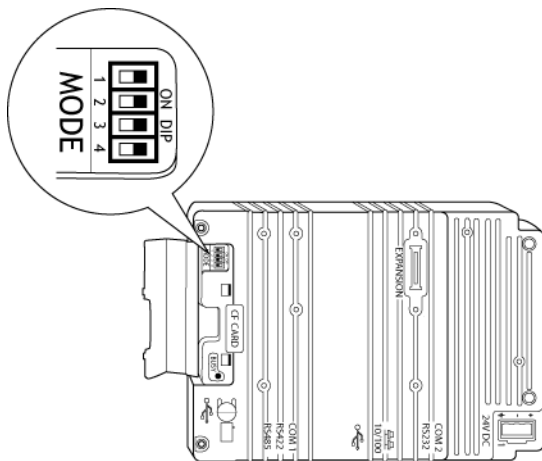

Changing Mode Switches

To change mode switches, follow the steps below:

1. Disconnect power from the operator panel.
2. Set the mode switches using a ballpoint pen.
3. Reconnect power to the operator panel.

Modes

The mode switches have the following functions: 1 = ON, 0 = OFF.

Each letter in "MODE" has a corresponding mode switch

WARNING! The modes below are to be used with caution

MODE	Description
0000	"Run-mode" - Boot CE, normal operation.
0010	System Restore, resets the file system and registry, reinstalls the system program (OPsys_bxxx.CAB). Restores the operator panel to factory settings. Warning! Information can accidentally be lost.
0100	Image Load mode (Sysload) allows upgrading of the firmware in the operator panel. Note: All files including the file system in the operator panel are deleted when upgrading with Image Loader.
1000	Service Menu mode, the service menu for the system program is shown. Allows the user to set IP configuration, erase the project, calibrate the touch screen, set the panel in Run/Transfer mode etc.
1100	Not used (Run-mode).
1110	Self-Test
xxx1	Hard reset (forces the system to reset).

2.2.2 Connections to the Controller

For information about the cables to be used when connecting the graphic operator terminal to the controller, please refer to the help file for the driver in question.

2.2.3 Other Connections and Peripherals

Cables, peripheral equipment and accessories must be suitable for the application and its environment. For further details or recommendations, contact Kollmorgen.

CAUTION! When using a compact flash card, do not remove the card when the busy indicator is illuminated.

3 TECHNICAL SPECIFICATIONS

This chapter provides the technical specifications for the graphic operator terminal.

3.1 Technical Data

The following table provides the electrical and mechanical specifications for the graphic operator terminal.

Parameters	AKI-CDF-MOD-10T
Front panel	382 x 252 x 6 mm (W x H x D)
Mounting depth	58 mm (158 mm including clearance)
Front panel seal	IP 66
Rear panel seal	IP 20
Keyboard material	Membrane switch keyboard with metal domes. Overlay film of Autotex F157 * with print on reverse side. 1 million operations.
Reverse side material	Powder-coated aluminum
Weight	2.5 kg
Serial port RS422 / RS485	25-pin D-sub contact, chassis-mounted female with standard locking screws 4-40 UNC.
Serial port RS232C	9-pin D-sub contact, male with standard locking screws 4-40 UNC.
Ethernet	Shielded RJ 45
USB	Host type A (USB 1.1), max output current 500 mA Device type B (USB 1.1)
Flash memory for application	12 MB (incl. fonts)
Real time clock	±20 PPM + error because of ambient temperature and supply voltage. Total maximum error: 1 min/month at 25 °C Temperature coefficient: 0.004 ppm/°C ²
Real time clock battery	CR2450 (UL and cUL: Sanyo or Panasonic) Minimum lifetime: 3 years
Power consumption at rated voltage	Normal: 0.5 A Maximum: 1.0 A
Display	TFT-LCD. 800 x 600 pixels, 64K colors. CCFL backlight lifetime at the ambient temperature of +25 °C: >50,000 h.
Active area of display	211.2 x 158.4 mm
Fuse	Internal DC fuse, 3.15 AT, 5 x 20 mm

Parameters	AKI-CDF-MOD-10T
Power supply	+24V DC (20 - 30V DC). Power supply connector. CE: The power supply must conform with the requirements according to IEC 60950 and IEC 61558-2-4. UL and cUL: The power supply must conform with the requirements for class II power supplies.
Ambient temperature	Vertical installation: 0 ° to +50 °C Horizontal installation: 0 ° to +40 °C
Storage temperature	-20 ° to +70 °C
Relative humidity	5 - 85 % non-condensed
CE approvals	Noise tested according to EN61000-6-4 emission and EN61000-6-2 immunity.
UL, cUL approvals (when product or packing is marked)	UL 1604 Class I, Div 2 / UL 508 / UL 50 4x indoor use only
DNV	Yes
NEMA	4x indoor use only

* See section Chemical Resistance for more information.

4 CHEMICAL RESISTANCE

This chapter describes the chemical resistance for the graphic operator terminal.

4.1 Metal Casing

The frame and casing material is powder-coated aluminum. This powder paint withstands exposure to the following chemicals without visible change:

Chemicals	
Acetic acid 10%	Phosphoric acid 4%
Citric acid 10%	Phosphoric acid 10%
Diesel	Sea water
Distilled water	Sodium chloride 2%
Edible oil	Sodium chloride 20%
Fuel oil	Euphoric acid 20%
Hydrogen peroxide 3%	Tap water

The powder paint shows limited resistance to the following chemicals at room temperature:

Chemicals	
Butanol	Nitric acid 3%
Hydrochloric acid 5%	Nitric acid 10%
Isopropyl alcohol	Phosphoric acid 43%
Na-hypochlorite 10%	Turpentine

Note: If exposure to any of the above chemicals is demanded, it is recommended to first test the chemical on an invisible spot of the metal casing.

The powder paint shows little or no resistance to the following chemicals at room temperature:

Chemicals		
Acetic acid, conc.	Methyl-ethyl ketone	Toluene
Acetone	Nitric acid 30%	Trichloroethylene
Ammonia 5%	Phenol	Xylene
Ammonia, conc.	Sodium hydroxide 5%	97 octane unleaded petrol
Ethyl acetate	Sodium hydroxide	98 octane leaded petrol

4.2 Key Panel and Overlay

This section provides information about the key panel and overlay for the device.

4.3 Autotex F157/F207

Autotex F157 or F207 covers the overlay surrounding the touch screen.

Solvent Resistance

Autotex F157/F207 withstands exposure of more than 24 hours duration under DIN42 115 Part 2 to the following chemicals without visible change:

Chemicals		
Acetonitrile	Diesel Downey / Lenor ¹	Phosphoric acid (<30%)
Ajax / Vim in solution	Ethanol	Potassium ferricyanide
Alkali carbonate solution ¹	Glycerin	Potassium hydroxide (<30%)
Ammonia (<40%) ¹	Glycol	Pure turpentine
Acetic acid (<50%)	Gumption ¹	SBP 60 / 95 ¹
Ariel powder in solution ¹	Hydrochloric acid (<36%)	Sulfuric acid (<10%)
Bleach ¹	Linseed oil	Tomato ketchup
Castor oil	Methanol	Tricloroacetic acid (<50%)
Caustic soda (<40%) ¹	Nitric acid (<10%)	White spirit
Cutting oil	Paraffin oil	Windex ¹
Cyclohexanol	Persil powder in solution ¹	Wisk
Diacetone alcohol	Petroleum spirit ¹	

¹ Extremely faint glossing of the texture was noted.

Autotex withstands DIN 42 115 Part 2 exposure of up to 1 hour duration to glacial acetic acid without visible change.

Autotex is not resistant to high pressure steam at over 100 °C or the following chemicals:

Chemicals	
Concentrated mineral acids	Benzyl alcohol
Concentrated caustic solution	Methylene chloride

Outdoor Use

In common with all polyester based films Autotex F157/F207 is not suitable for use in conditions of long term exposure to direct sunlight.

4.4 Key Panel Surface

The key panel surface on the terminal withstands exposure to the following solvents without visible change:

Solvents	Time
Acetone	10 minutes
Isopropanol	10 minutes
Toluene	5 hours

4.5 Key Panel Protector

It is recommended to use the Key Panel Protector film that can be ordered from Kollmorgen.

Solvent Resistance

The Key Panel Protector film withstands exposure to the same chemicals as Autotex F157 or F207 according to section Autotex F157/F207.

Outdoor Use

In common with all polyester based films, Key Panel Protector film is not suitable for use in conditions of long term exposure to direct sunlight.

5 OPERATOR TERMINAL DIAGRAMS

This chapter provides the operator terminal diagrams.

5.1 Communication Port Diagrams

RS-232

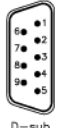

Pin no	Signal	Signal Name	Signal direction
1	DCD	Data Carrier Detect	Input
2	RD	Receive Data	Input
3	TD	Transmit Data	Output
4	DTR	Data Terminal Ready	Output
5	SG	Signal Ground	-
6	DSR	Data Set Ready	Input
7	RTS	Request To Send	Output
8	CTS	Clear To Send	Input
9	RI	Ring Indicator	Input

D-sub
9-pin Male

RS-422/485

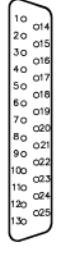

Pin no	RS-422		RS-485	
	Signal	Signal direction	Signal	Signal direction
2	TxD+	Output	Tx/Rx+	In/Output
15	TxD-	Output	Tx/Rx-	In/Output
3	RxD+	Input		
16	RxD-	Input		
4	RTS+	Output		
17	RTS-	Output		
5	CTS+	Input		
18	CTS-	Input		
20	1)			
21	1)			
6	Do not use		2) Bus termination	4) Connect to pin no.19 for bus-termination.
19	Do not use		3) Bus termination	See above
7,8	0V		0V	
14	+5V <100mA	Output	+5V <100mA	Output

D-sub
25-pin Female

- 1) Pin no 20 connected to pin no 21 internal in the terminal
- 2) Directly connected internally to pin no. 2 (Tx/Rx+).
- 3) Connected to pin no. 15 (Tx/Rx-) internally via a 120ohm 1/4W resistor.
- 4) NOTE! Only the first and the last unit on the bus should be terminated.

USB

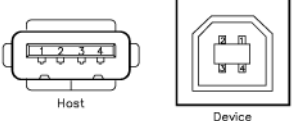

Pin no	Signal	Signal direction
1	VBUS	-
2	D-	In/Output
3	D+	In/Output
4	GND	-

Host Device

Frame connected to chassis.

Ethernet

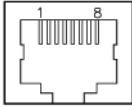

Pin no	Signal	Signal direction
1	Tx+	Output
2	Tx-	Output
3	Rx+	Input
6	Rx-	Input
4,5,7,8	GND	

5.2 Outline Diagrams

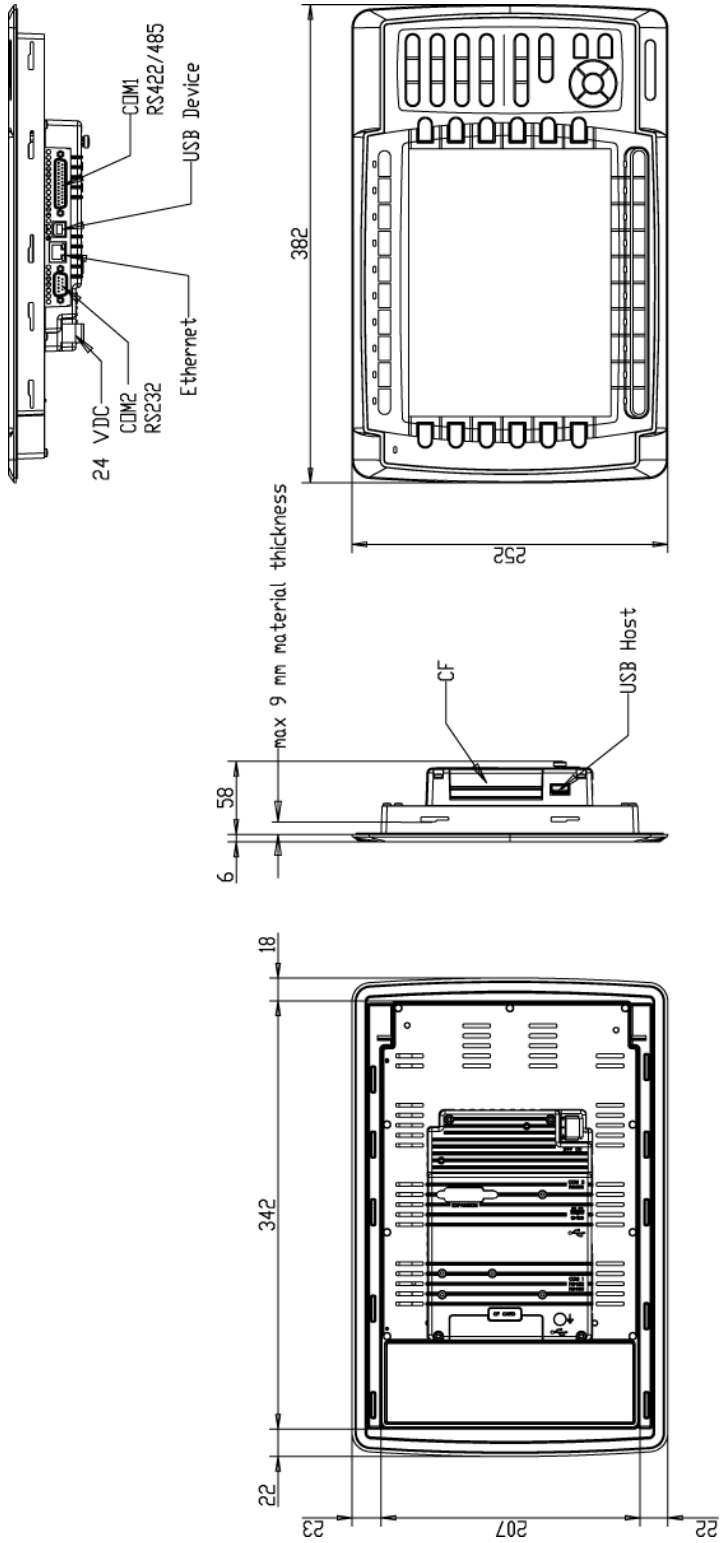

5.3 Text Strip Diagram

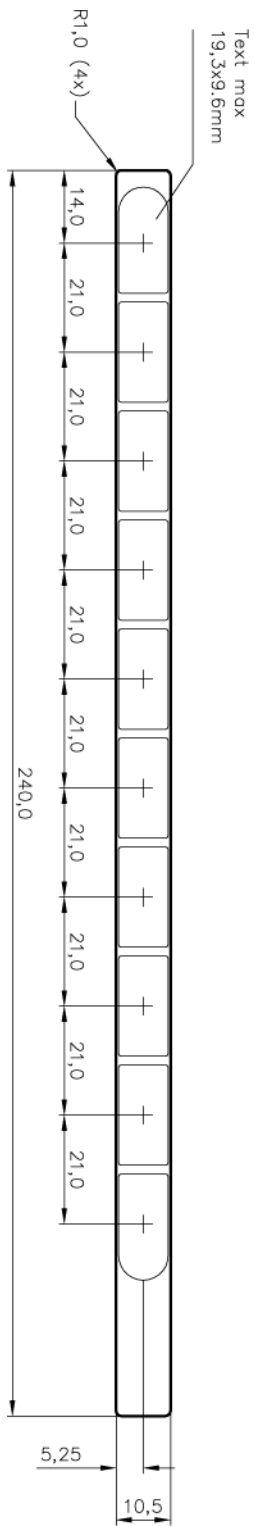

6 INSTALLATION TIPS

When experiencing communication problems in noisy environments or when operating close to temperature limits, observe the following recommendations.

6.1 Grounding the Operator Terminal

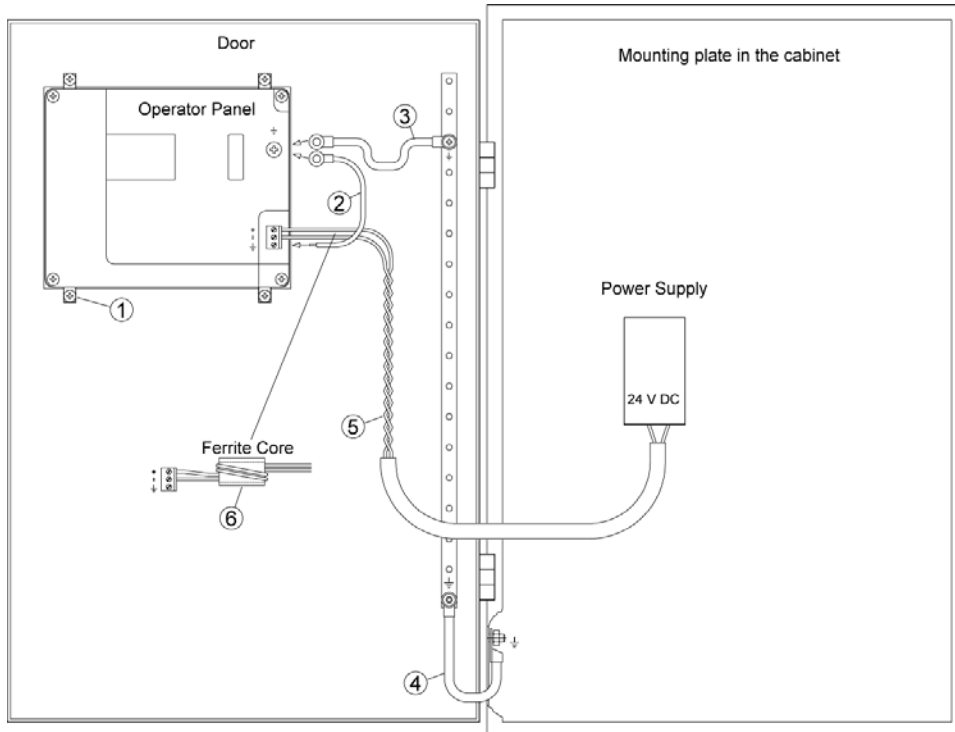

- The graphic operator terminal's mounting clamps do not provide a secure grounding connection between the terminal and the device cabinet.
- Connect a 2.5 mm² wire between the graphic operator terminal's quick-connect plinth and the terminal chassis.
- Connect a 6 or 4 mm² wire or grounding braid between the terminal's chassis and the closest grounding point on the door.
- Connect a strong but short grounding braid between the door and the device cabinet.
- Twist the cables onto the 24 V DC feed.
- A ferrite core suppresses disturbances to the 24 V feed:
 - Two turns around the ferrite core provide four times the suppression of one turn.
 - Three turns around the ferrite core provide nine times the suppression of one turn.

Note: The grounding wires should be short and the conductor should have a large area. A long, thin grounding wire has very high impedance (resistance) at high frequencies and will not guide disturbances to the ground. Multi-wire conductors are better than single wire conductors with the same area. A braided conductor wire with the same area is better. The best is a short, thick grounding braid.

6.2 Ethernet Connection in the Terminal

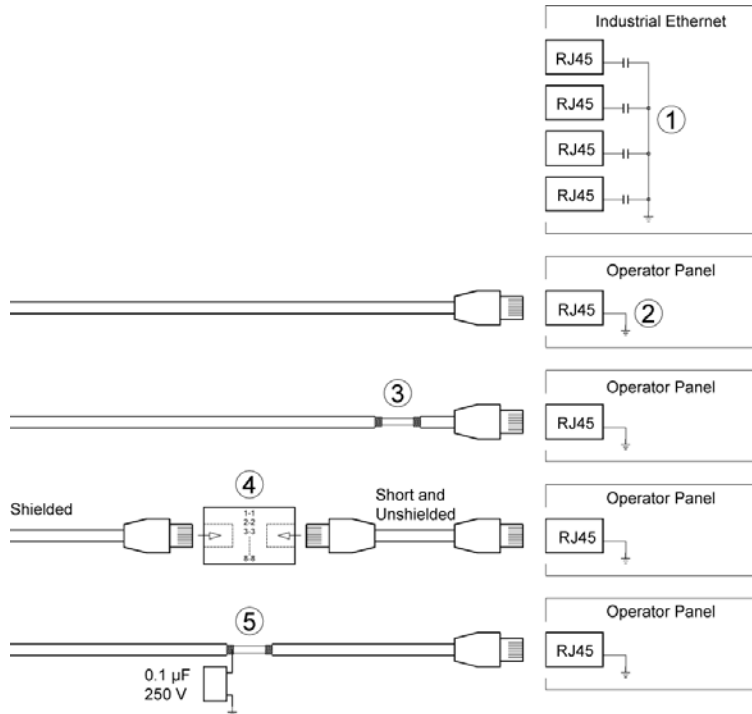

- In some industrial units for Ethernet, the RJ45 contact's shield is connected to the chassis via a capacitor.
- The graphic operator terminal's Ethernet shield is directly connected to the chassis.

Check whether the other Ethernet unit has its shield directly grounded or grounded via a capacitor.

In many cases, connecting the shielded Ethernet cabling to the chassis at both ends is inappropriate. Hum or grounding loops can occur. Unshielded cabling may even result in fewer communication errors.

As a solution, use a shielded Ethernet cable. However, only connect the shield at one end.

- A possible option is to break the shield.
- Another option is to expand the shielded Ethernet cabling with a piece of unshielded Ethernet cable.
- You can ground the shield via an external 0.1 uF/250 V plastic capacitor. This will connect the HF transients to the ground.

6.3 Achieving EMC Protection

The following suggestions should be taken into consideration to achieve better EMC protection:

- Initially, use the original cabling from Kollmorgen primarily.
- Use shielded cables for RS232 communication.
- Use twisted pair and shielded cabling for RS422 and RS485.
- Use the cabling intended for the bus type; Ethernet, Profibus, CC-Link, CAN, Device Net etc.
- Install and connect according to applicable specifications for the relevant bus standard.
- Use shielded cabling for Ethernet, preferably with foil + braided shield.
- D-sub covers should be shielded and the shield should be connected to the cover 360 ° where the cable comes in.
- Connect the shield at both ends.

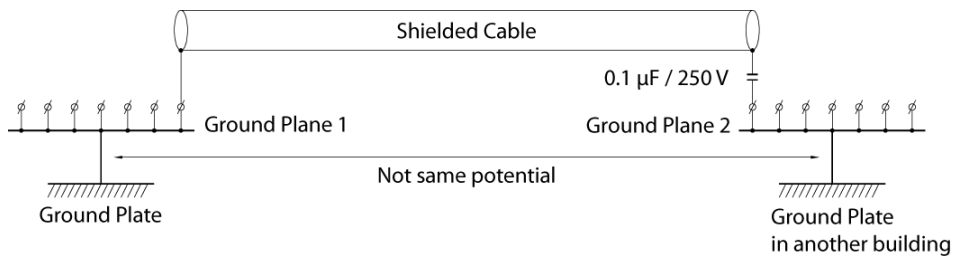

With longer distances, there is a risk that the ground potential may be different. In this scenario, the shield should only be connected at one end. A preferred alternative is to connect the other end of the shield to the ground via a 0.1 uF/250 V plastic capacitor. Both ends are then connected to the ground in terms of HF, but only connected to the ground at one end in terms of LF, thus avoiding the 50 Hz grounding loops.

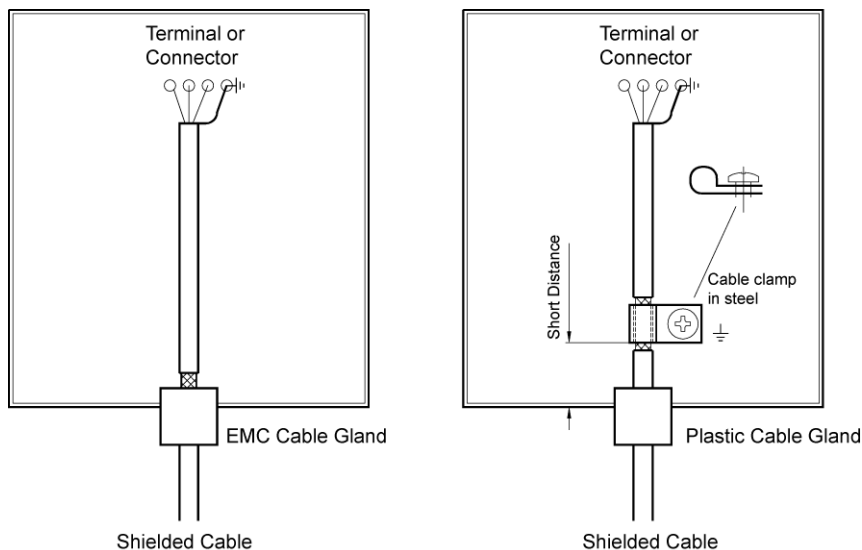

Use an EMC cable gland or regular plastic cable gland. Remove the outer jacket and connect the shield to the installation plate with a 360 ° metal cable clamp.

Place the 24 V DC and communications cabling in one cable trunk/cable duct and 230/380 V AC in another. If the cables need to be crossed, cross them at 90 ° only. Avoid combining the cabling for stronger 24 V DC outputs with the communication cabling.

Ferrite cores that are snapped onto the shielded cabling may remove minor disturbances. Large ferrite pieces that are snapped onto unshielded cabling and where the wires go 2-4 times around the cores are approximately 5-25 times more efficient.

6.4 Ambient Temperature

The maximum ambient temperature for the graphic operator terminal is provided in the specifications. The ambient temperature refers to the temperature in the device cabinet which cools the terminal's electronics.

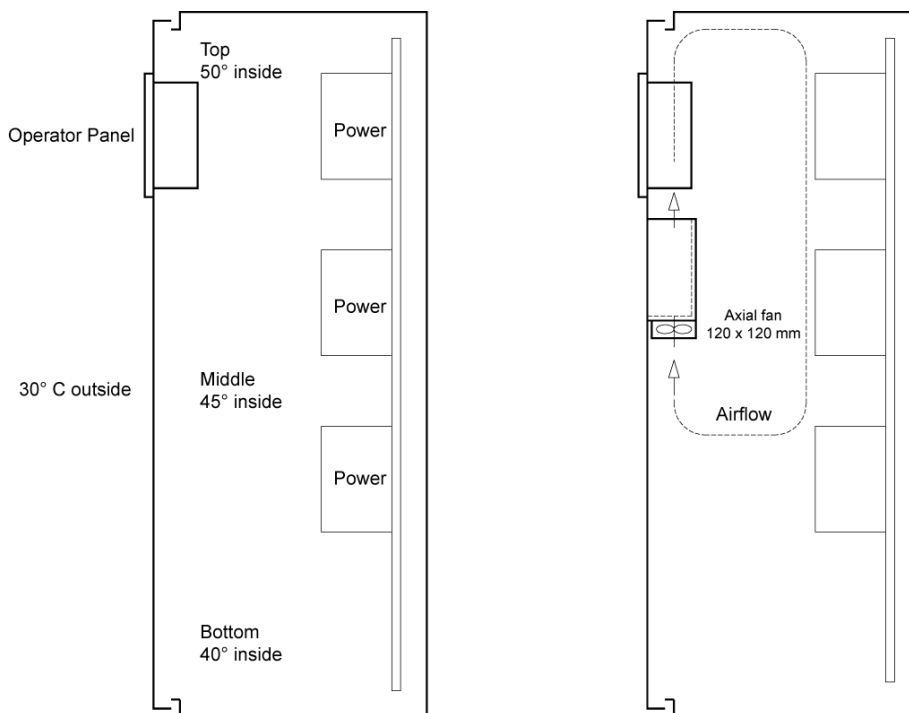

In most cases, the ambient temperature for the graphic operator terminal is significantly higher than the device cabinet's ambient temperature.

If the cabinet is tall and there are a number of heat-generating devices, the temperature at the top of the cabinet is considerably higher than the theoretical temperature increase that is expected. All electronics are sensitive to heat. The lifespan of an electrolytic capacitor is cut in half with an 8-10 ° increase in temperature. A 15-20 ° temperature increase results in a quarter of the lifespan etc.

Note: An enamel-coated steel cabinet has a radiant heat value of 5.5 W/m² and degrees C.

Installing a fan inside the cabinet will even out the temperature, while moving air provides considerably better cooling than still air. A suitable fan is a 120 x 120 mm axial fan, available in 24 V DC, 115, and 230 V AC.

Install the fan so that it sits in the cooler area and blows cold air against the graphic operator terminal. If the fan is mounted at the top and sucks air upwards, the fan's ambient temperature is higher resulting in a shorter lifespan.

A good fan with a ball-bearing mounting has an expected lifespan of at least 40,000 hours (not a guaranteed lifespan) at 40 °C. This corresponds to at least 4 years of continuous use. If a thermostat is installed, the fan only needs to come on when needed.

Large graphic terminals draw only one fifth of the current when the background lighting is off. The loss effect drops from e.g. 25 W to only 5 W. The graphic operator terminal's loss effect = supply voltage x current. Virtually no power goes to external users and no loss effects due to inputs.

6.5 Safety

Most of the graphic operator terminals are powered with 24 V DC.

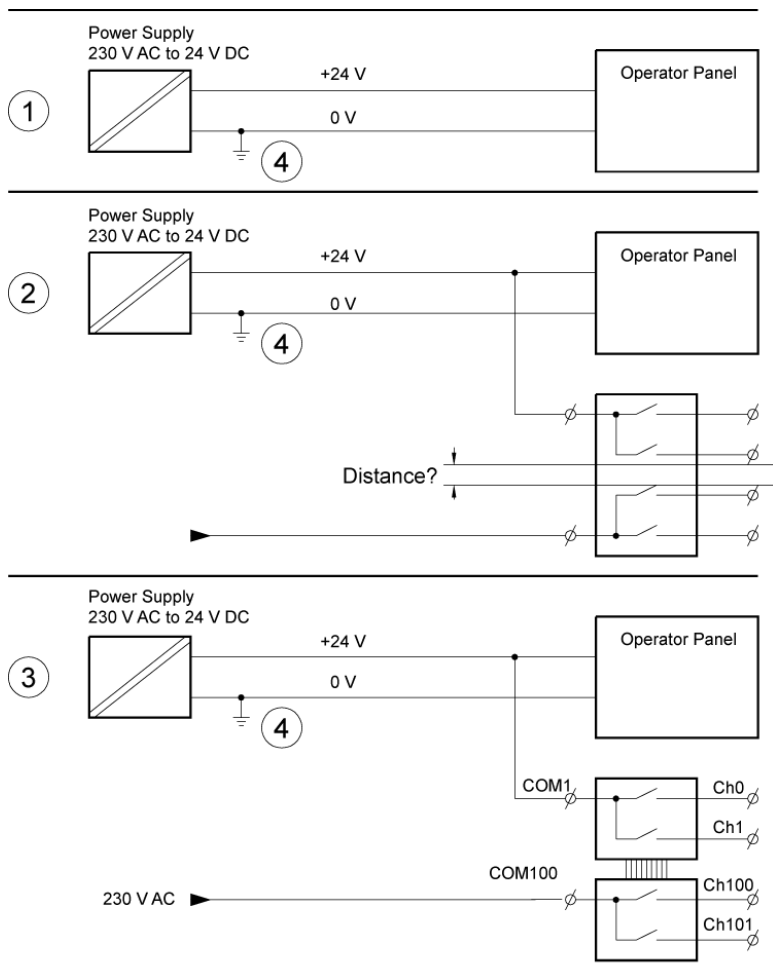

If you use a power supply that meets safety standards and only supplies the graphic operator terminal, no problems should occur. However, use caution if you have a 24 V unit that also supplies other units.

WARNING! The graphic operator terminal does not have insulation that meets safety requirements in the event of a potential short circuit between 230 V AC and 24 V DC. It is assumed that the 24 V feed is secure. For example, SELV according to EN 60950 (protection against electric shock) and UL 950.

Example: This example explains why a secure 24 V DC feed can be ruined by mixing 24 V relay contacts with 230 V AC relay contacts in a smaller controller. Check that the clearances and creep age distances between 24 V DC and 230 V AC fulfill EN 60950 or UL 950. If not, input a separate 24 V unit into the graphic operator terminal.

- If there is a substantial distance between the relay contacts for 24 V DC and 230 V AC, it is safe to use the same 24 V devices for all feeds.
- Connect 0 V on the 24 V feed to the ground. This offers three advantages:
 - Safety is increased. The 24 V feed will not be live in the event of a faulty connection or short circuit between 0 V (24 V) and 230 V phase.
 - Transients on the 24 V feed are connected to the ground.
 - No risk that the 24 V feed is at a high level in relationship to the ground. This is not unusual since there is high static electricity.

6.6 Galvanic Isolation

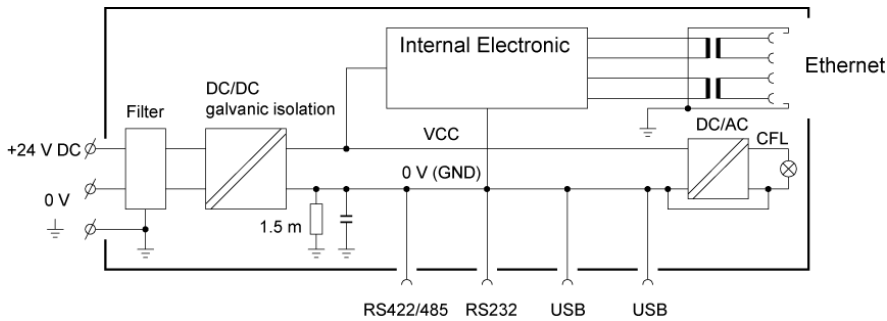

The graphic operator terminal has galvanic isolation against the 24 V DC feed but no galvanic isolation between the communication ports for RS232, RS422/485 and USB. Only the Ethernet connection isolation has galvanic isolation.

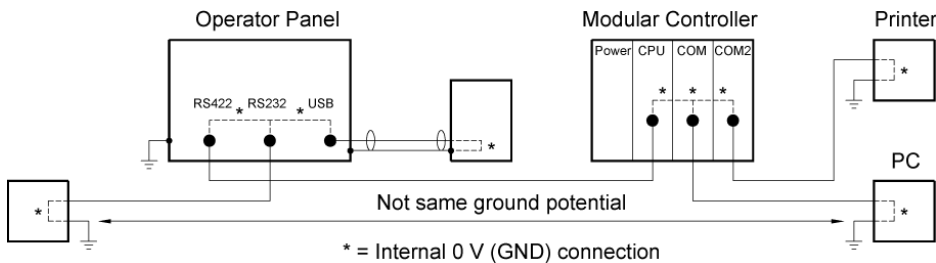

When a PC is connected to the terminal, the terminal's internal 0 V (GND) is connected to the protective ground via the PC.

A number of USB devices can have the shield connected together with the protective ground. Here, the terminal's 0 V (GND) is connected to the protective ground. For example, a USB memory stick, keyboard or similar device is plugged in.

If a number of units are connected have a 0 V and a ground connection, and these units are connected to various grounding points, there is a substantial risk of problems. Grounding currents go through communication cables, the rear plate of the controller, and internally in the graphic operator terminal, and can cause errors.

Note: It is important to make sure that the 24 V feed in the external insulation unit is not connected to one of the communication outlets. If it does not have 100% insulation against the 24 V feed, disturbances and grounding currents from the 0 V on the 24 V side will disrupt communication.

Using this type of unit solves one problem but may create a larger problem! A substandard installation may work now, but problems may arise when other devices are connected.

6.7 Cable and Bus Termination RS485

- Use shielded and twisted pair cable.
The pair capacitance may not exceed 52.5 pF/m and area at least 0.25 mm² (AWG 24), if you want to use the maximum transfer distance and maximum transfer speed.
- 0 V, the reference voltage for communication should be included in the cabling. With two-way communication use two pairs; one pair for communication and one pair for 0 V.
- The shield must be grounded at one end. The other end is usually grounded, but with longer distances or when there is a difference in the ground potential, the shield should be connected to the ground via 0.1 uF/250 V plastic capacitor to prevent ground current in the braided shield.

A number of manufacturers recommend that the shield be grounded at each node. Various manufacturers have different systems for bus termination. The RS485 standard does not describe how the Fail Safe function is carried out, just that the system should be able to handle the error.

Depending on the recipients' design, the bus wires may be on the same level or require pull-up or pull-down to ensure that no faulty signals are detected when the bus is in resting mode (all transmitters are disconnected).

APPENDIX A

This section provides the mechanical drawings of the AKI-CDF-MOD-10T 10.4" HMI Graphic Operator Terminal.

A.1 AKI-CDF-MOD-10T 10.4" – Front View 1

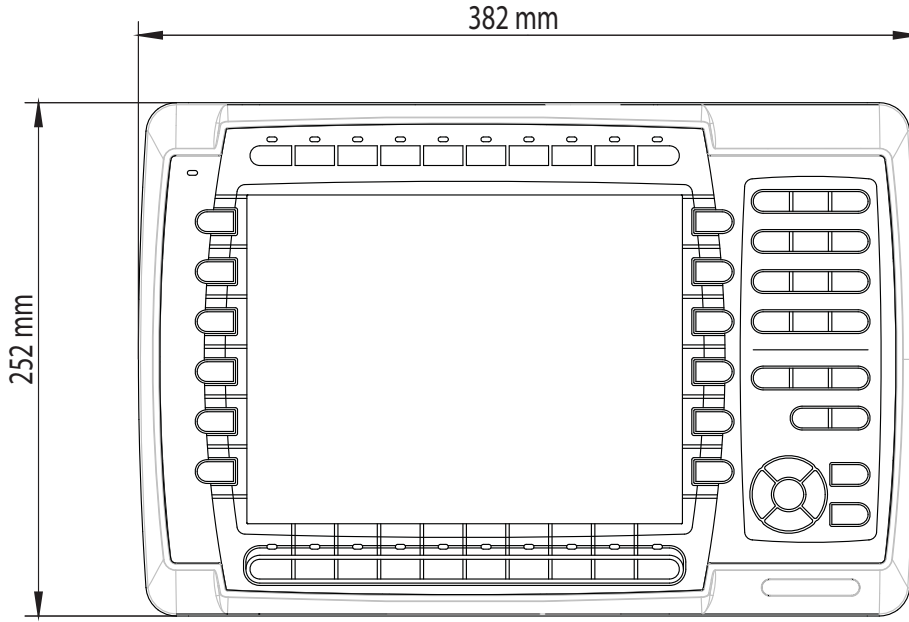

A.2 AKI-CDF-MOD-10T 10.4" – Front View 2

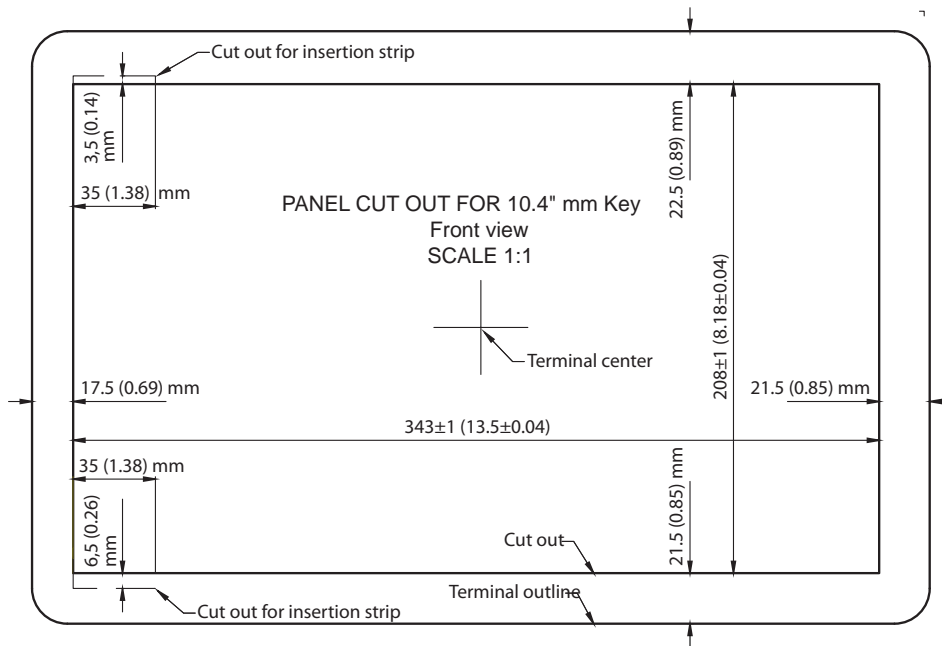

A.3 AKI-CDF-MOD-10T 10.4” – Bottom View

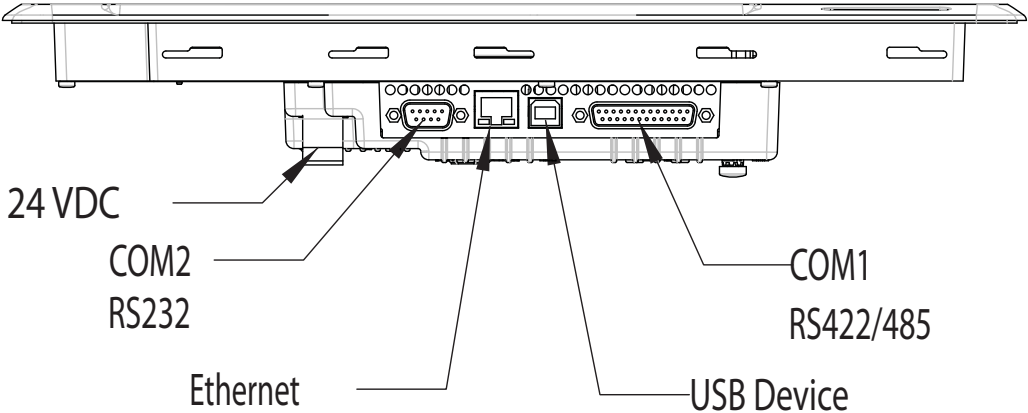

A.4 AKI-CDF-MOD-10T 10.4” – Side View

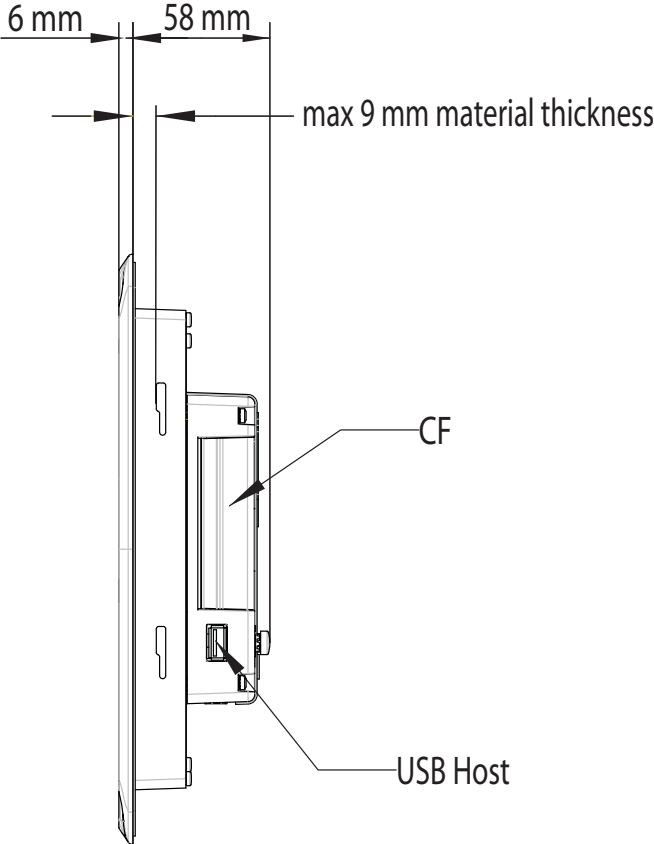

A.5 AKI-CDF-MOD-10T 10.4" – Back View

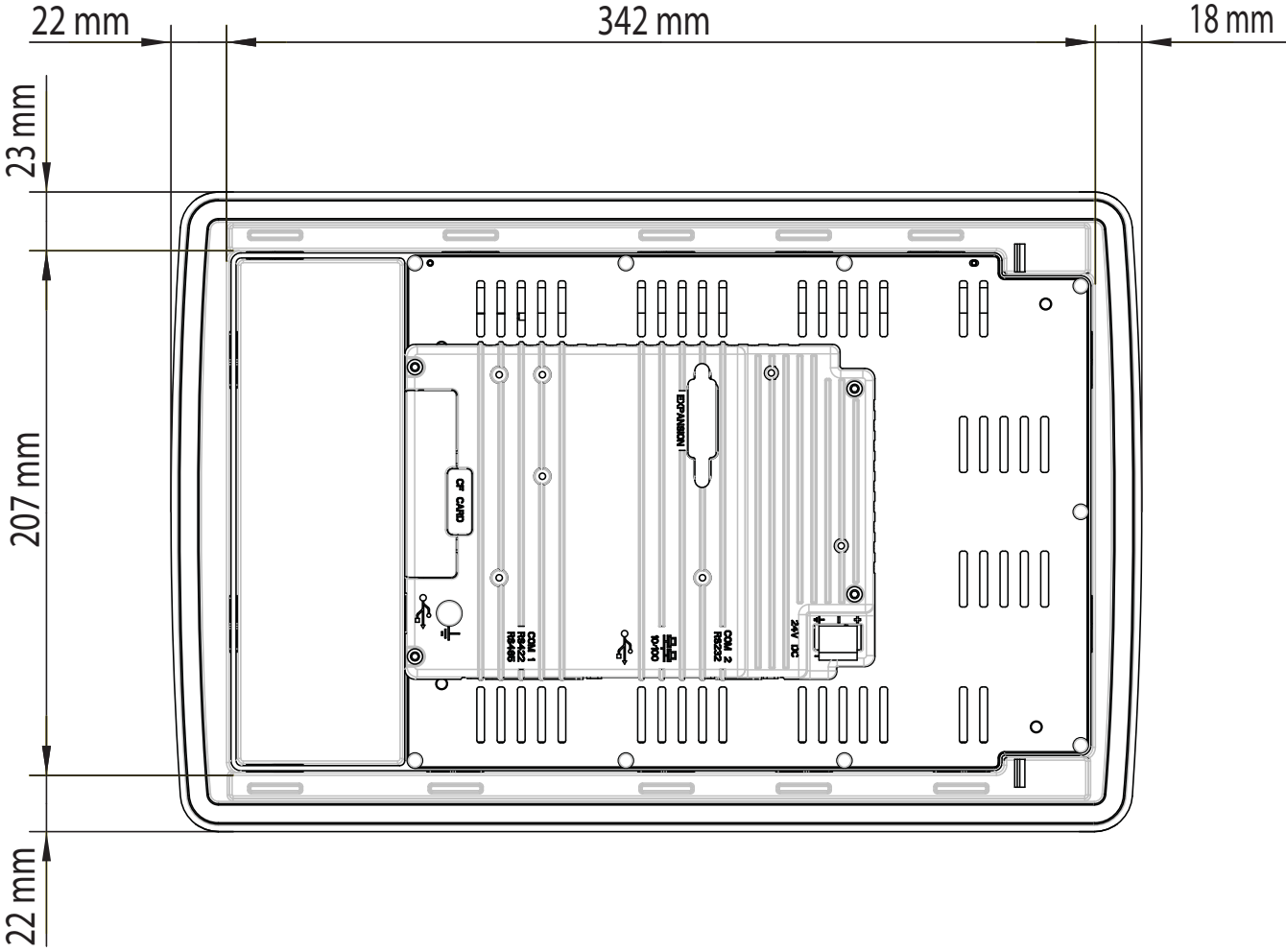

About Kollmorgen

Kollmorgen is a leading provider of motion systems and components for machine builders. Through world-class knowledge in motion, industry-leading quality and deep expertise in linking and integrating standard and custom products, Kollmorgen delivers breakthrough solutions that are unmatched in performance, reliability and ease-of-use, giving machine builders an irrefutable marketplace advantage.

For assistance with your application needs, contact us at: 540-633-3545, contactus@kollmorgen.com or visit www.kollmorgen.com

North America

Kollmorgen

203A West Rock Road
Radford, VA 24141 USA
Phone: 1-540-633-3545
Fax: 1-540-639-4162

Europe

Kollmorgen

Wacholderstraße 40 – 42
40489 Düsseldorf Germany
Phone: + 49 (0) 2039979235
Fax: + 49 (0) 20399793314

KOLLMORGEN[®]

Because Motion Matters™