

AKD[®]2G / AKD[®] / S700

Accessories Guide

North American Edition



Edition: September 2020, North America, Revision K

Part Number: 903-200007-00

Original Document



For safe and proper use, follow these instructions. Keep for future use.

KOLLMORGEN

Because Motion Matters™

Record of Document Revisions

| Revision | Remarks |
|----------------|--|
| Rev A, 12/2009 | Original version |
| Rev B, 08/2012 | Updated revision |
| Rev C, 09/2012 | Minor updates to formatting. |
| Rev D, 09/2012 | Minor updates to formatting. |
| Rev E, 05/2013 | Notes added on 300V and 600V Value line cable routing standards. Chapter on capacitor modules added. |
| Rev F, 09/2013 | Pinout drawings added for linear motor adapters. Section added for Kollmorgen™ Ethernet cables. |
| Rev G, 12/2014 | Regen resistor model support changed. |
| Rev H, 12/2015 | Filter order information clarified. |
| Rev J, 11/2019 | Added AKD2G accessories |
| Rev K, 09/2020 | Updated AKD2G connector descriptions and codes. |

Trademarks

- EnDat is a registered trademark of Dr. Johannes Heidenhain GmbH
- EtherCAT® is registered trademark and patented technology, licensed by Beckhoff Automation GmbH, Germany
- Windows is a registered trademark of Microsoft Corporation
- AKD is a registered trademark of Kollmorgen™ Corporation

Technical changes which improve the performance of the device may be made without prior notice.

Printed in the United States of America

This document is the intellectual property of Kollmorgen™. All rights reserved. No part of this work may be reproduced in any form (by photocopying, microfilm or any other method) or stored, processed, copied or distributed by electronic means without the written permission of Kollmorgen™.

1 Table of Contents

| | | |
|----------|--|-----------|
| 1 | Table of Contents | 3 |
| 2 | General | 6 |
| 2.1 | About this Manual | 6 |
| 2.2 | Symbols | 6 |
| 2.3 | General Safety Instructions | 6 |
| 3 | Digital Drive Systems | 7 |
| 3.1 | Drive System with AKD-x00306 to 02406 | 7 |
| 3.2 | Drive System with AKD-x00307 to 02407 | 8 |
| 3.3 | Drive System with AKD-x04807 | 9 |
| 3.4 | Decentralized Drive System with AKD-C and AKD-N | 10 |
| 3.5 | Drive System with AKD2G-Sxx-6VxxD | 11 |
| 3.6 | Drive System with AKD2G-Sxx-7VxxD | 12 |
| 3.7 | Drive System with S701 to 724 | 13 |
| 3.8 | Drive System with S748 to S772 | 14 |
| 4 | Mechanical Tools | 15 |
| 4.1 | Safety Instructions | 15 |
| 4.2 | Mounting Kit for AKMH Motors | 15 |
| 4.3 | Suspension Unit for AKM8 Motors | 16 |
| 4.4 | Heat Sink for AKD-N | 17 |
| 4.5 | Mounting clamps for AKD-N | 17 |
| 5 | Input, Output, and Feedback Accessories | 18 |
| 5.1 | X9 Screw Terminal Adapter, AKD-X9ADPT | 18 |
| 5.2 | Linear Motor Adapter | 18 |
| 5.2.1 | ACI-AKD-A Pinout Drawing | 19 |
| 5.2.2 | ACI-AKD-B Pinout Drawing | 19 |
| 6 | Shielding Accessories | 20 |
| 6.1 | Safety Instructions | 20 |
| 6.2 | Shield Plates | 20 |
| 6.3 | AKD Shield Plates | 20 |
| 6.3.1 | AKD-z-zzz06 Shield Plate | 20 |
| 6.3.2 | AKD-z-00307, AKD-z-00607, AKD-z-01207 Shield Plate | 21 |
| 6.3.3 | AKD-z-02407 Shield Plate | 21 |
| 6.4 | Connector Tool for AKD-N | 22 |
| 6.5 | Sealing plugs for AKD-N connectors | 22 |
| 6.6 | AKD, AKD2G and S701 to S724 Shield Clamps (purchased separately) | 23 |
| 6.7 | S748 to S772 Shield Clamps (purchased separately) | 23 |
| 6.8 | External Shielding Busbar (purchased separately) | 24 |
| 7 | Mating Connectors and Adapters | 26 |
| 7.1 | Connectors for AKD-B/P/T/M | 26 |
| 7.2 | Connectors for AKD-C | 27 |
| 7.3 | Connectors for AKD-N | 27 |
| 7.4 | Connectors for AKD2G | 28 |
| 7.5 | Smart Feedback Adapter (SFA) for AKD2G | 29 |
| 8 | Mains Chokes | 30 |

| | | |
|-----------|---|-----------|
| 8.1 | Safety Instructions | 30 |
| 8.2 | Type Assignment | 31 |
| 8.3 | Order Codes | 31 |
| 8.4 | Mains Choke 3L | 32 |
| 9 | Mains Filters | 33 |
| 9.1 | Safety Instructions | 33 |
| 9.2 | Type Assignment | 33 |
| 9.3 | Order Codes | 34 |
| 9.4 | Mains filters FN2090 | 35 |
| 9.5 | Mains filters 1NF-10...12 | 36 |
| 9.6 | Mains filters FN3288 | 37 |
| 9.7 | Mains filters 1NF-20B, 1NF-25 | 38 |
| 9.8 | Mains Filters 3NF-07...30 | 39 |
| 10 | Capacitor Modules | 40 |
| 10.1 | Important Notes | 40 |
| 10.2 | Order Codes | 41 |
| 10.3 | KCM Module | 42 |
| 10.4 | External Regen Resistor BAFP(U) | 43 |
| 11 | Brake/Regeneration Resistors | 44 |
| 11.1 | Safety Instructions | 44 |
| 11.2 | Type Assignment | 45 |
| 11.3 | Order Codes | 46 |
| 11.4 | External Regen Resistor BAFP(U) | 47 |
| 11.5 | External Regen Resistor BAR(U) | 48 |
| 11.6 | External Regen Resistor BAS(U) | 49 |
| 12 | Motor Chokes | 50 |
| 12.1 | Shielded Motor Cables | 50 |
| 12.2 | Safety Instructions | 51 |
| 12.3 | Type Assignment | 51 |
| 12.4 | Motor Choke 3YLN-xx | 52 |
| 13 | Cables | 53 |
| 13.1 | PC Connection | 53 |
| 13.2 | Kollmorgen™ Ethernet Cables | 53 |
| 13.3 | AKD Performance Cables | 54 |
| 13.3.1 | Hybrid Cables | 54 |
| 13.3.2 | AKD Hybrid Cables by Motor Type | 54 |
| 13.3.3 | Dual Cables | 55 |
| 13.3.4 | AKD Value Line Cables | 55 |
| 13.3.5 | Digital/analog Inputs/Outputs | 56 |
| 13.3.5.1 | Digital I/O cable for AKD-N | 56 |
| 13.3.5.2 | STO cable for AKD-N-DS | 56 |
| 13.3.5.3 | Fieldbus cable for AKD-N-DF | 56 |
| 13.3.5.4 | AKD-N Performance Cables | 57 |
| 13.3.5.5 | Hybrid Cable Connecting AKD-C Power Supply to AKD-N Axis Module | 57 |
| 13.3.5.6 | Hybrid Cable Connecting AKD-N Axis Module to AKD-N Axis Module | 57 |
| 13.3.5.7 | Hybrid Cable Connecting AKD-N Axis Module to AKM Motor | 58 |
| 13.3.5.8 | Performance Cables for AKD-N-DF/DS to AKM Motor | 58 |

| | |
|---|-----------|
| 13.3.6 CANopen Bus Cables for AKD | 59 |
| 13.4 Motor Power and Feedback Cables | 60 |
| 13.4.0.1 Power Cables | 60 |
| 13.4.0.2 Feedback Cables | 60 |
| 13.4.1 Order Codes for S700 Motor Power Cables | 61 |
| 13.4.1.1 S724 Order Codes | 61 |
| 13.4.1.2 S748 Order Codes | 61 |
| 13.5 Preparing Motor Cables (Motor End) | 62 |
| 13.5.1 Motor Series AKM2...8, 6SMx7, DBL2...6, DBK | 62 |
| 13.6 Preparing Cables for Drive (S701 to S724) | 63 |
| 13.7 CANopen Bus Cable Specifications | 64 |
| 13.7.1 CANopen Cable P-AKD-CAN-RJ-z-zz | 64 |
| 13.7.2 CANopen Cable P-AKD-CAN-TERM | 65 |
| 13.7.3 CANopen Cable PAKD-CAN-9D-0-15 | 65 |
| 13.7.4 Motor Power Cable Specifications | 66 |
| 13.7.4.1 Cable Routing Standards | 66 |
| 13.7.4.2 AKD 1.5 – 6 A Power Cable, VP-507BEAN-xx | 66 |
| 13.7.4.3 AKD 12 A Power Cable, VP-508CEAN-zz | 67 |
| 13.7.4.4 AKD 12 A Power Cable with Brake, VP-508CFAN-zz | 68 |
| 13.7.4.5 AKD 24 A Power Cable with Brake, VP-508DEAN-zz | 69 |
| 13.7.4.6 AKD 24 A Power Cable with Brake, VP-508DFAN-zz | 70 |
| 13.7.5 CANopen Cable PAKD-CAN-FL-3-00 | 71 |
| 13.8 Motor Feedback Cable Specifications | 72 |
| 13.8.1 Cable Routing Standards | 72 |
| 13.8.2 Motor Feedback Cable, VF-DA0-474N-zz | 72 |
| 13.8.3 Feedback Resolver Cable, VF-RA2474N-zz | 73 |
| 13.8.4 Sine Encoder Feedback Cable, VF-SB4474N-zz | 74 |
| 13.8.5 Resolver Cables for S700/AKD | 75 |
| 13.8.5.1 Resolver Cable Order Codes | 75 |
| 13.8.5.2 Preparing Resolver Cables | 76 |
| 13.8.6 Encoder Cables for S700/AKD | 77 |
| 13.8.6.1 Encoder Cable Order Codes | 77 |
| 13.8.6.2 Preparing Encoder Cables | 77 |
| 13.8.7 ComCoder Cables for S700/AKD | 79 |
| 13.8.7.1 ComCoder Cable Order Codes | 79 |
| 13.8.7.2 Preparing ComCoder Cable | 80 |





2 General

2.1 About this Manual

This manual describes accessories for the AKD2G, AKD and S700 drives and contains essential technical data. This manual is only valid in conjunction with the manuals for the AKD2G drive, AKD drive and applicable motor in your application.

The manuals for AKD2G, AKD and S700 drives are included on the disk shipped with the drives and on the Kollmorgen website (www.kollmorgen.com). These documents are available in PDF format in multiple languages (system requirements: Windows, internet browser, and Acrobat Reader). In all pdf versions, the table of contents and index entries are active bookmarks. Page/chapter numbers in the text with cross references are active links to the target material.

2.2 Symbols

| Symbol | Meaning |
|---|---|
|  | Indicates a hazardous situation which, if not avoided, will result in death or serious injury. |
|  | Indicates a hazardous situation which, if not avoided, could result in death or serious injury. |
|  | Indicates a hazardous situation which, if not avoided, could result in minor or moderate injury. |
|  | This is not a safety symbol. Indicates situations which, if not avoided, could result in property damage. |
|  | This is not a safety symbol. This symbol indicates important notes. |

2.3 General Safety Instructions

CAUTION

- This manual is only valid in conjunction with the manuals for the drive and motor in your application.
- You must read the installation manual for the drive and motor in your application and observe the safety instructions in this manual before beginning mounting/installation work.
- Improper or incorrect cable assembly, mounting, or wiring can result in damage to property and equipment or personnel injury. The following requirements for specialist personnel apply:
 - Transport: only by personnel with knowledge of handling electrostatically sensitive components.
 - Unpacking: only by electrically qualified personnel.
 - Cable assembly: only by electrically qualified personnel.
 - Installation: only by electrically qualified personnel.
 - Commissioning: only by qualified personnel with extensive knowledge of electrical engineering /drive technology.
- Observe the specific safety instructions for each product group.
- The maximum cable lengths that are given must not be exceeded, otherwise the drive and motors may not function properly.
- Kollmorgen™ is not liable for faults or damage to the connected equipment caused by cables that have been configured by customers.

3 Digital Drive Systems

The systems shown are possible scenarios for setting up a digital drive system with relevant components.

3.1 Drive System with AKD-x00306 to 02406

Shielded Cable —————
 Electrical Ground - - - - -
 Optional Devices - - - - -

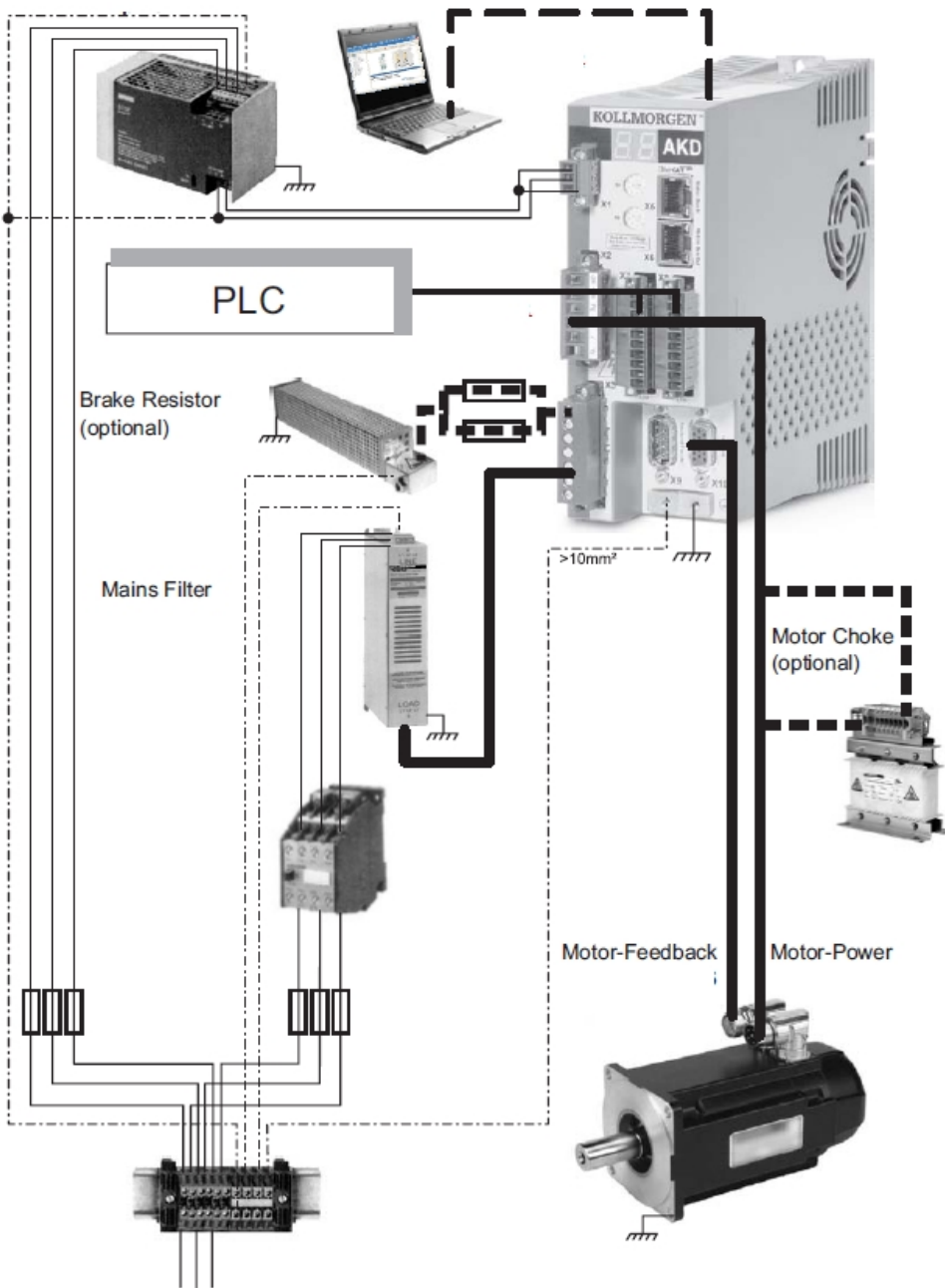

3.2 Drive System with AKD-x00307 to 02407

Shielded Cable ————
 Electrical Ground - - - - -
 Optional Devices - - - - -

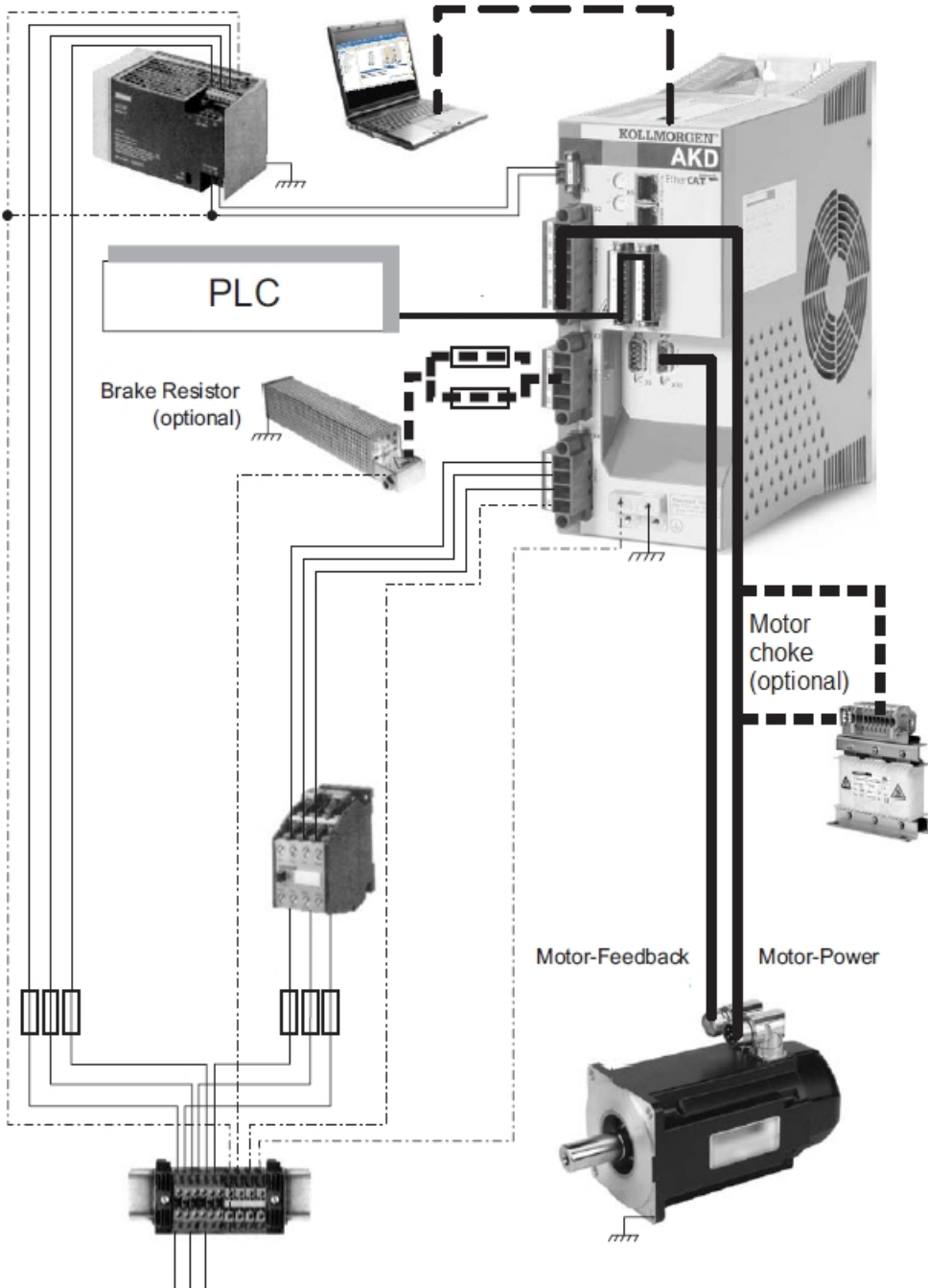

3.3 Drive System with AKD-x04807

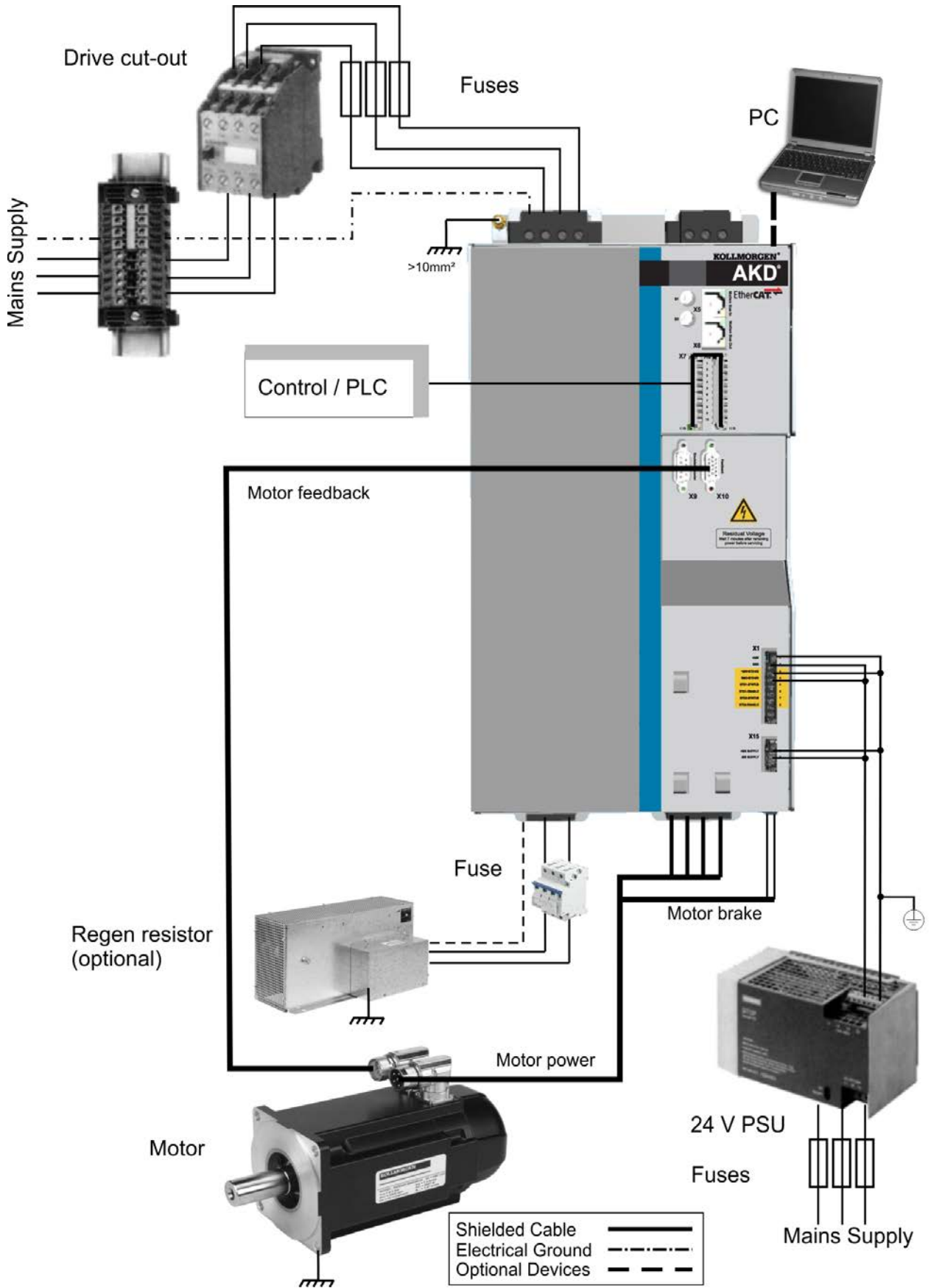

3.4 Decentralized Drive System with AKD-C and AKD-N

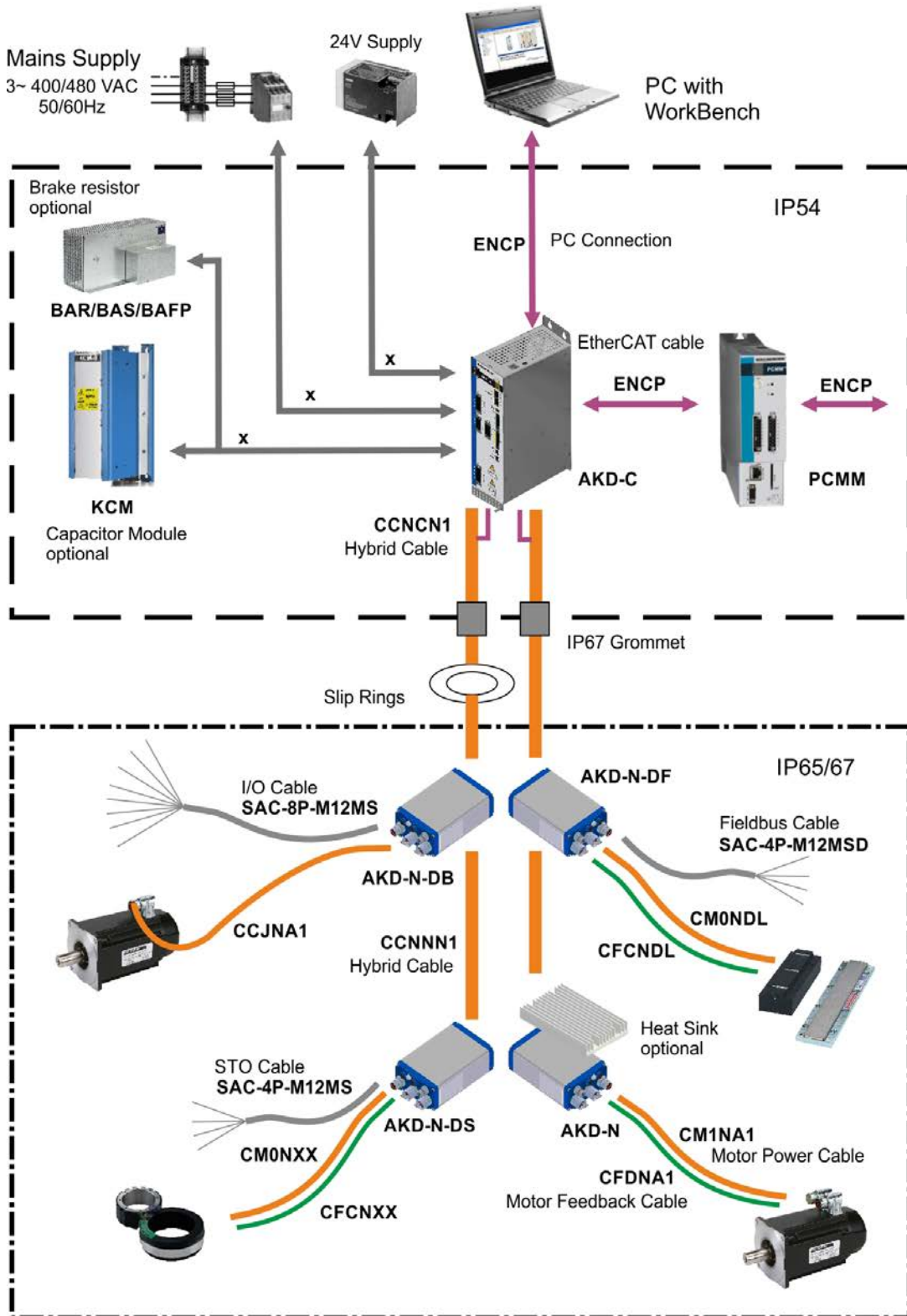

All components inside the borders are supplied by Kollmorgen with the exception of cables signed with "x". These cables are not supplied by Kollmorgen, you should use cables or wires according to EN 60204.

3.5 Drive System with AKD2G-Sxx-6VxxD

Example with single and dual cable motor connection on a dual axes drive. The number of available axes depend on the drive variant.

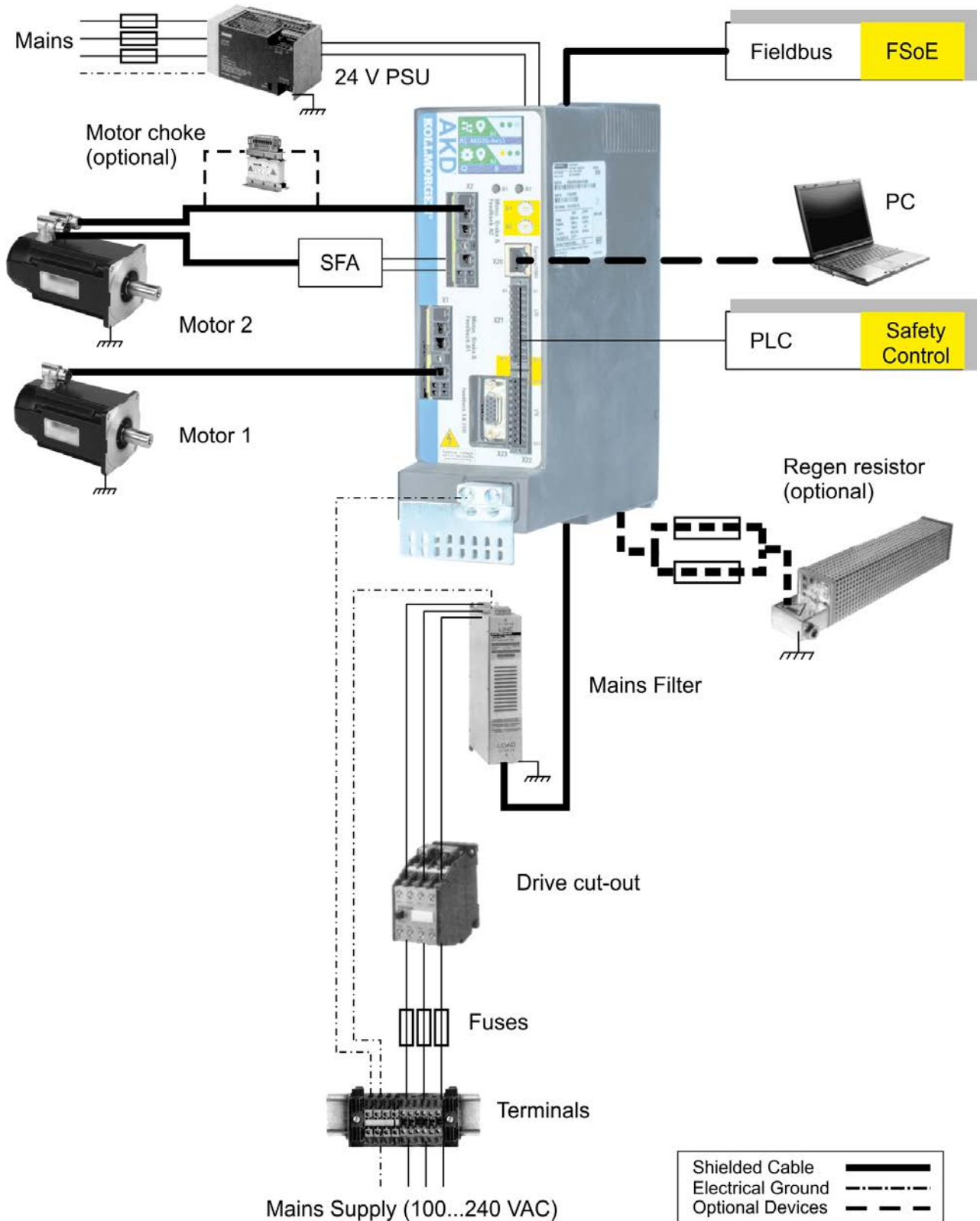

3.6 Drive System with AKD2G-Sxx-7VxxD

Example with single and dual cable motor connection on a dual axes drive. The number of available axes depend on the drive variant.

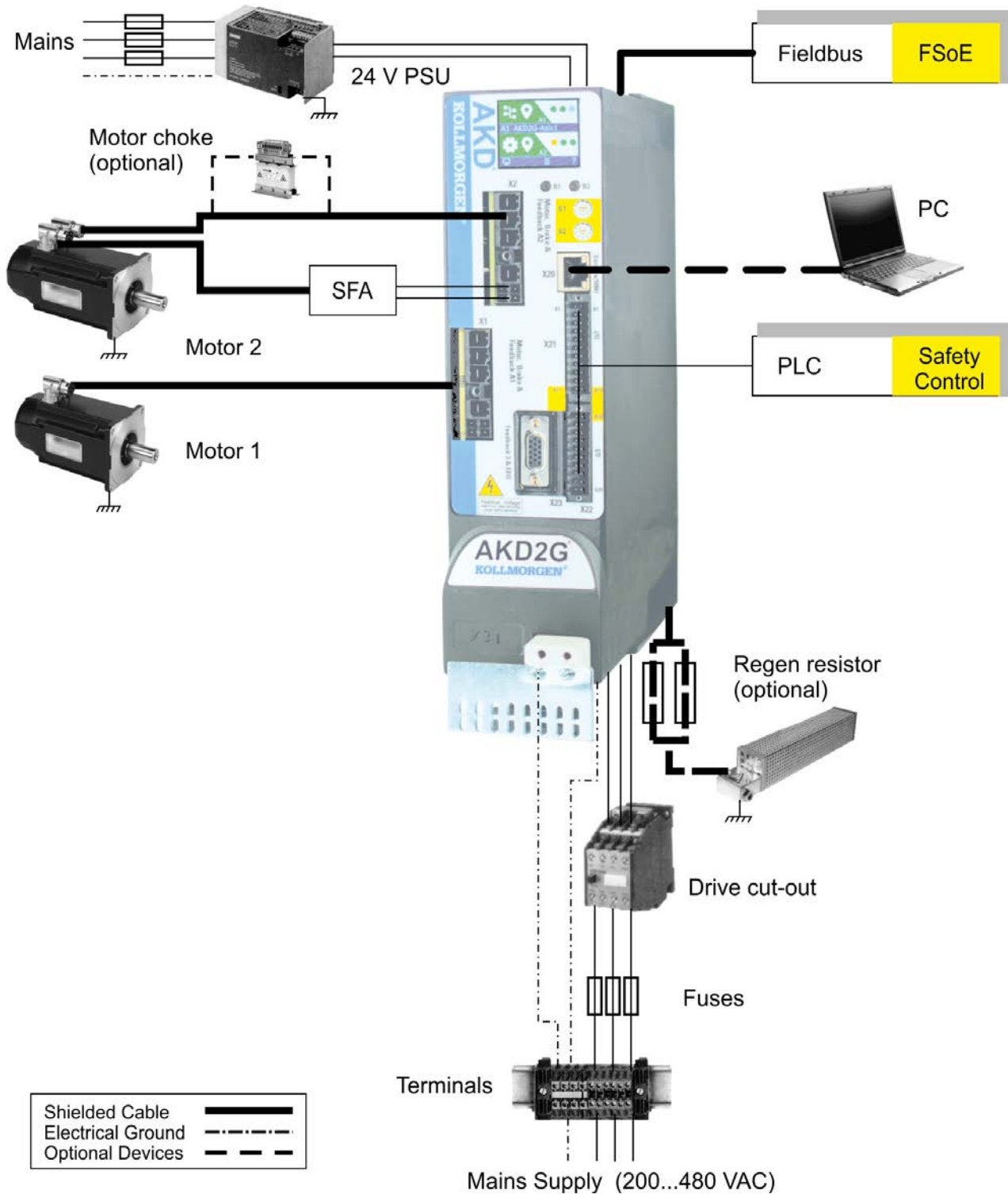

3.7 Drive System with S701 to 724

Shielded Cable ————
 Electrical Ground - - - - -
 Optional Devices - - - - -

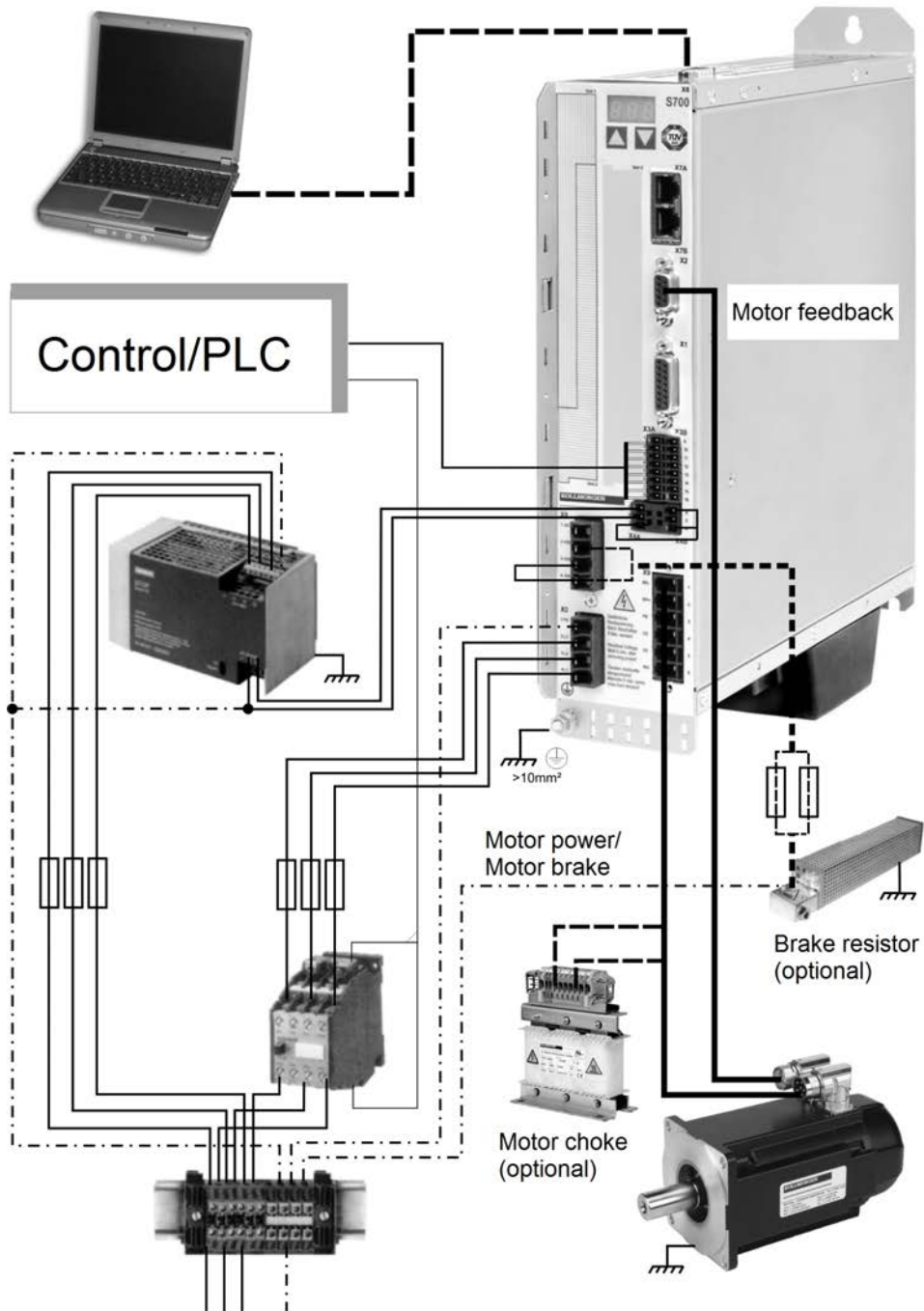

3.8 Drive System with S748 to S772

- Shielded Cable ————
- Electrical Ground - - - - -
- Optional Devices - - - - -

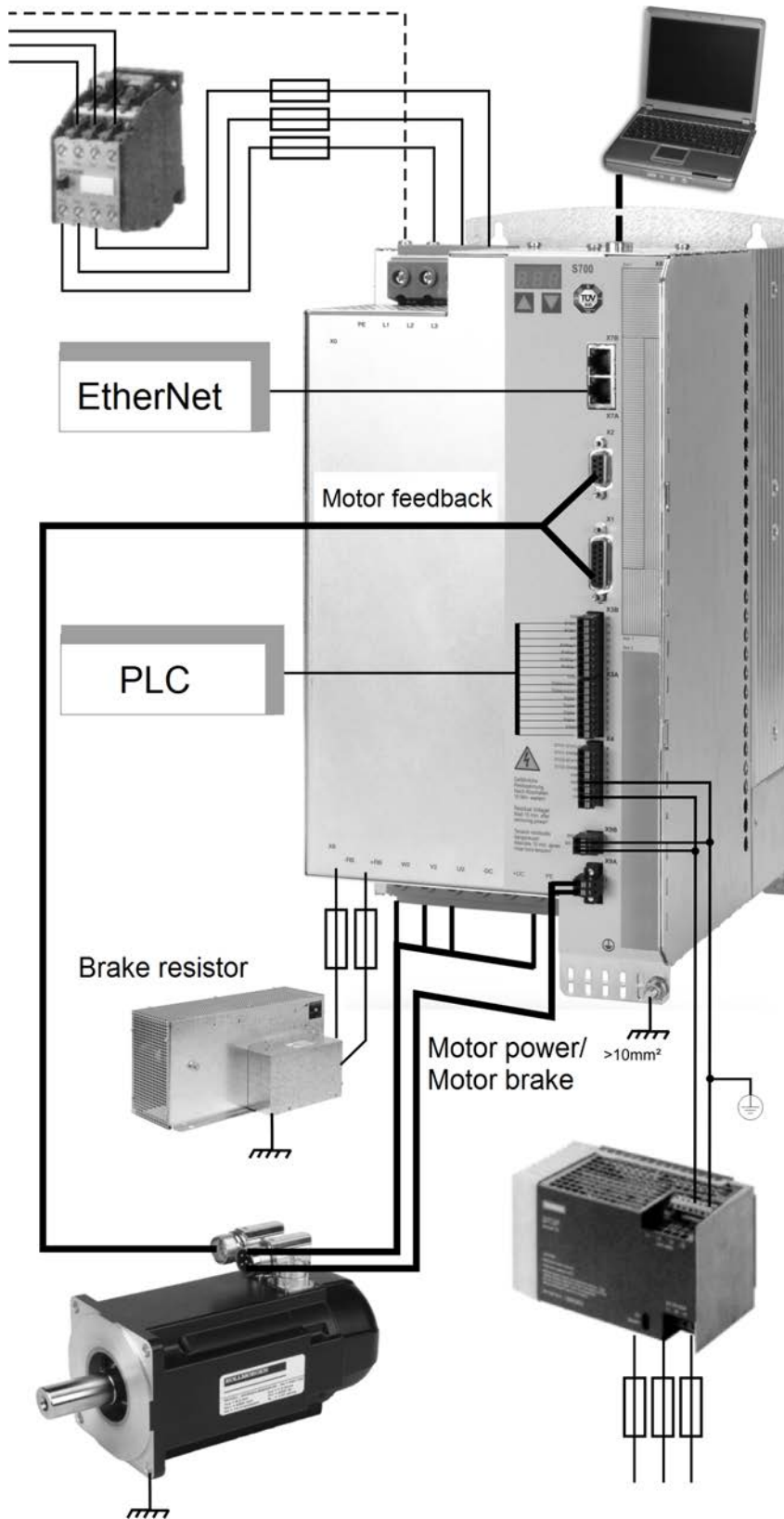

4 Mechanical Tools

4.1 Safety Instructions

⚠ CAUTION

This manual is only valid in conjunction with the instruction manual for the drive and motor you are using in your application.

4.2 Mounting Kit for AKMH Motors

IEC mounting kits with 1 shaft center screw and 4 flanges screws. Hygienic mounting is possible only with these screws.

| Description | Order Code |
|--|-------------------|
| Mounting Hardware AKMH2, Ax flange/Cx front mounting | MTG-KIT-AKMH2-IEC |
| Mounting Hardware AKMH3, Ax flange/Cx front mounting | MTG-KIT-AKMH3-IEC |
| Mounting Hardware AKMH4, Ax flange/Cx front mounting | MTG-KIT-AKMH4-IEC |
| Mounting Hardware AKMH5, Ax flange/Cx front mounting | MTG-KIT-AKMH5-IEC |
| Mounting Hardware AKMH6, Ax flange/Cx front mounting | MTG-KIT-AKMH6-IEC |

4.3 Suspension Unit for AKM8 Motors

⚠ CAUTION

You must read the instruction manual for the suspension unit ZPMZ 120/292. Observe and follow the safety instructions for this item.

The Suspension Unit ZPMZ 120/292 is designed for suspending motors only, without attached units such as gearboxes, and clutches. The suspension unit is designed for a maximum motor weight of 120 kg and maximum nominal span of the extreme suspension hooks of 292 mm.

The suspension unit consists of a beam (suspended off the crane hook) and two double-run chain suspenders. The motor may be suspended on two or four runs of the chain suspender.

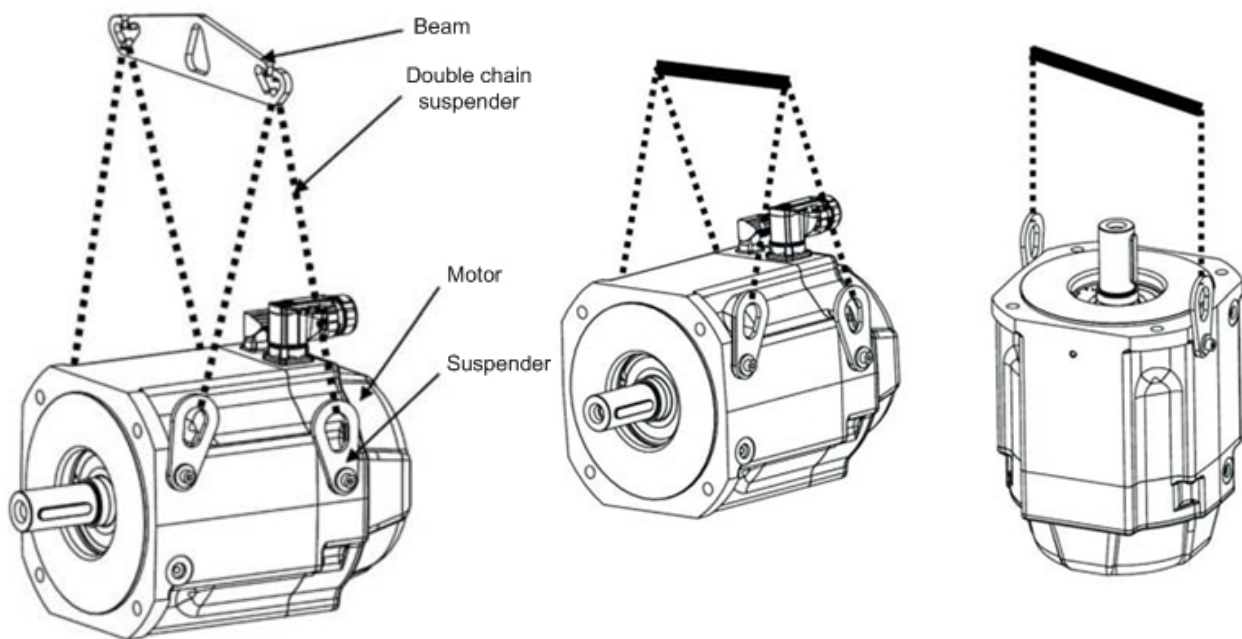

The suspenders (number depends on the motor type) are delivered with the motor.

| Technical Data | Value |
|---------------------------|---------|
| Lifting capacity | 120 kg |
| Nominal span | 292 mm |
| Lug width | 44.7 mm |
| Lug height | 51 mm |
| Weight | 0.83 kg |
| Number of cycles per year | 20,000 |
| Average load | 60 % |
| Order code | FA00092 |

4.4 Heat Sink for AKD-N

When mounting AKD-N to the machinery, temperature management is important to ensure maximum performance of the drive system. In case of bad cooling situation (as described in the AKD-N Installation Manual), you can mount a heat sink to the AKD-N.

Heat flow is optimized by a heat conducting film, which must be placed between heat sink and AKD-N.

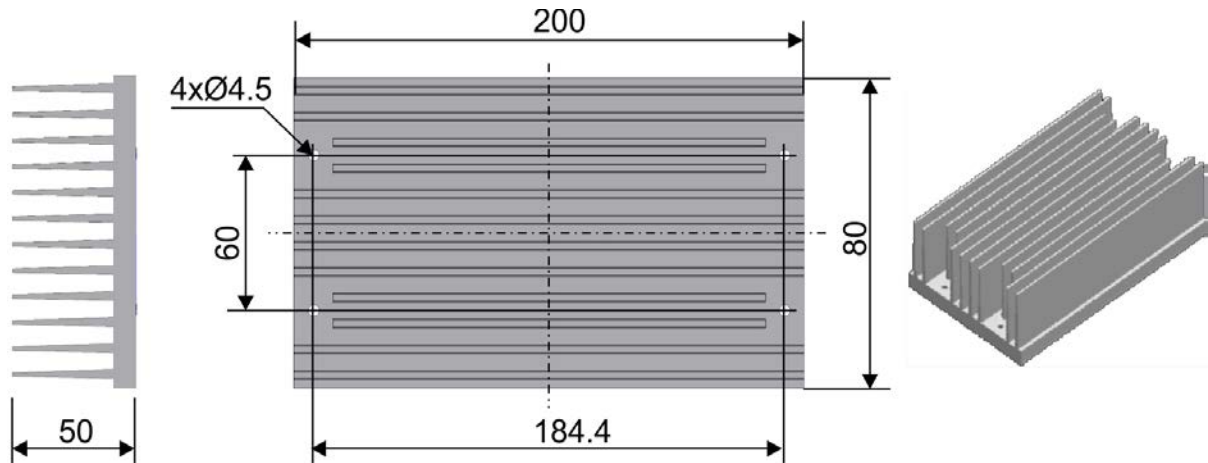

Order Codes

| Description | Usable for | Order codes |
|--|--------------|-----------------------------|
| Heat sink Kit 50 mm with heat conducting film and 4 screws M4x16 | AKD-N003/006 | AKD-N 3,6 HEATSINK KIT 50MM |
| Heat sink Kit 50 mm with heat conducting film and 4 screws M4x16 | AKD-N012 | AKD-N 12 HEATSINK KIT 50MM |
| Heat conducting film | AKD-N003/006 | 849-373001-04 |
| Heat conducting film | AKD-N012 | 849-374001-04 |

4.5 Mounting clamps for AKD-N

The AKD-N drive is mounted to the machine with special mounting clamps. The delivery package contains 4 clamps. In case of lost or damaged clamps, you can order a set of four clamps.

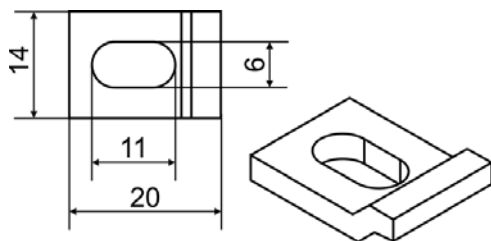

Order Codes

| Description | Order codes |
|-------------------------------------|---------------|
| AKD-N Mounting Clamps Set, 4 clamps | AKD-N-M/C-Set |

5 Input, Output, and Feedback Accessories

5.1 X9 Screw Terminal Adapter, AKD-X9ADPT



The AKD X9 screw terminal adapter plugs into the X9 port for testing of the X9 port connection. This item is not used with S700 drives.

5.2 Linear Motor Adapter



Linear motor adapters are used to combine feedback, Hall, and thermal sensors. They have connectors for standard Kollmorgen™ DDL connections. The linear feedback device is customer supplied, and two different adapter models are available for common linear feedback types. This item is not used with S700 drives.

| Item | Linear Feedback Type |
|-----------|----------------------|
| ACI-AKD-A | Heidenhain |
| ACI-AKD-B | Renishaw |

5.2.1 ACI-AKD-A Pinout Drawing

ACI-AKD-A (Heidenhain type)

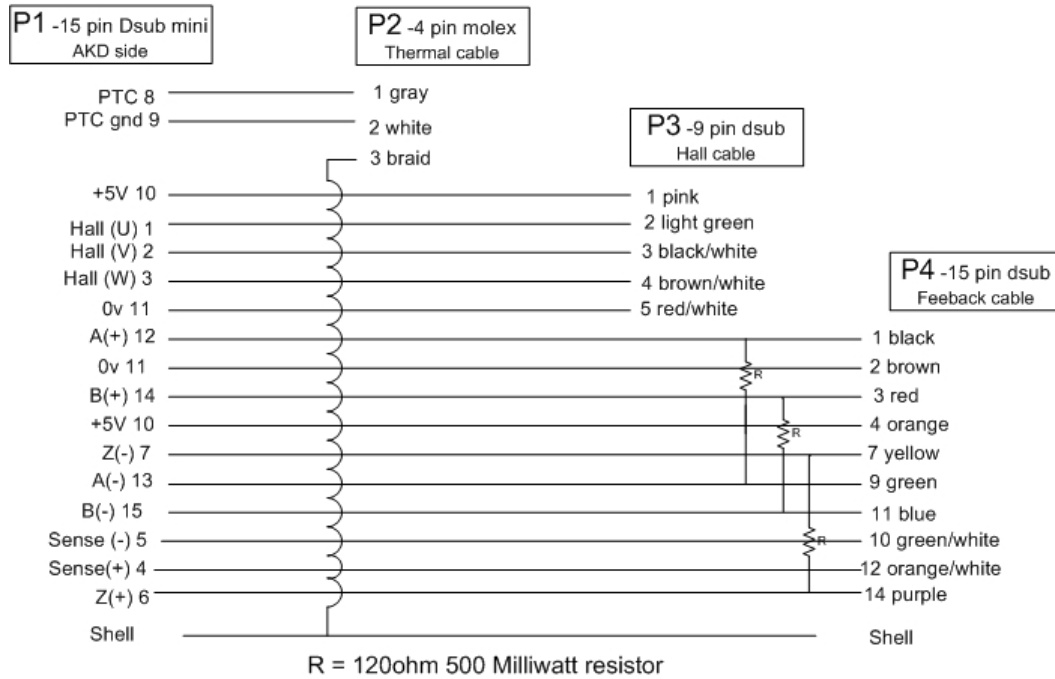

5.2.2 ACI-AKD-B Pinout Drawing

ACI-AKD-B (Renishaw Sine/Cos type)

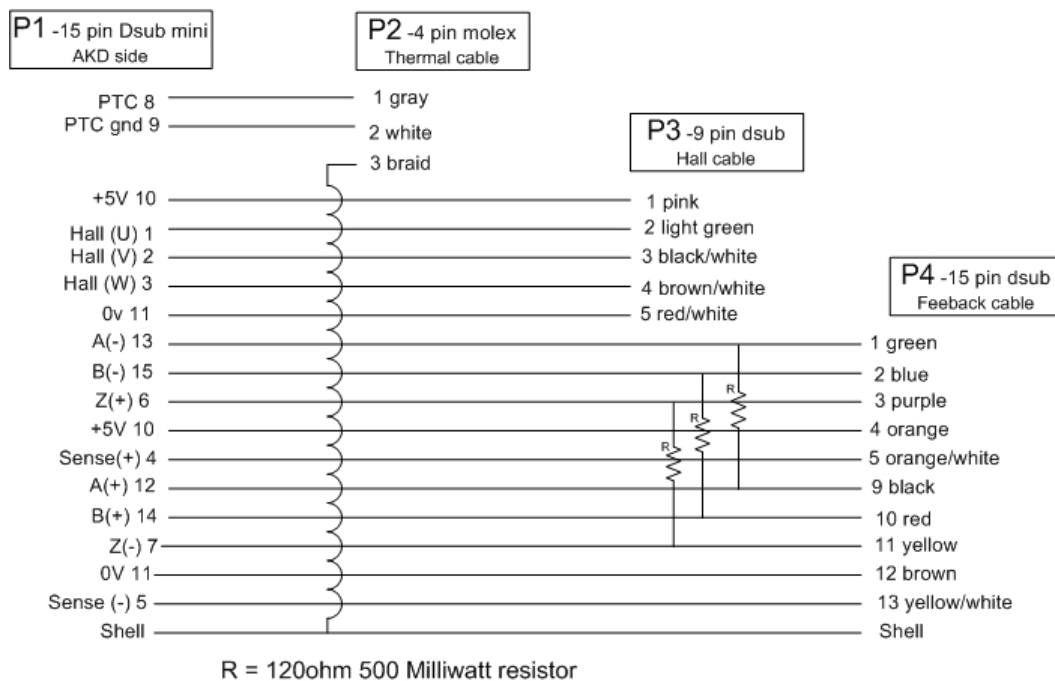

6 Shielding Accessories

6.1 Safety Instructions

⚠ CAUTION

- You must read the instructions manual for the drive/motor you are using in your application and observe the safety instructions they contain before beginning mounting/installation work.
- This manual is only valid in conjunction with the instruction manuals for the drive and motor you are using in your application.

6.2 Shield Plates

Shield plates can be attached to drives to assist in grounding and routing cabling.



6.3 AKD Shield Plates

6.3.1 AKD-z-zzz06 Shield Plate

This shield plate is not included with AKD-z-zzz06, but can be ordered separately (Item 153-230000-01).

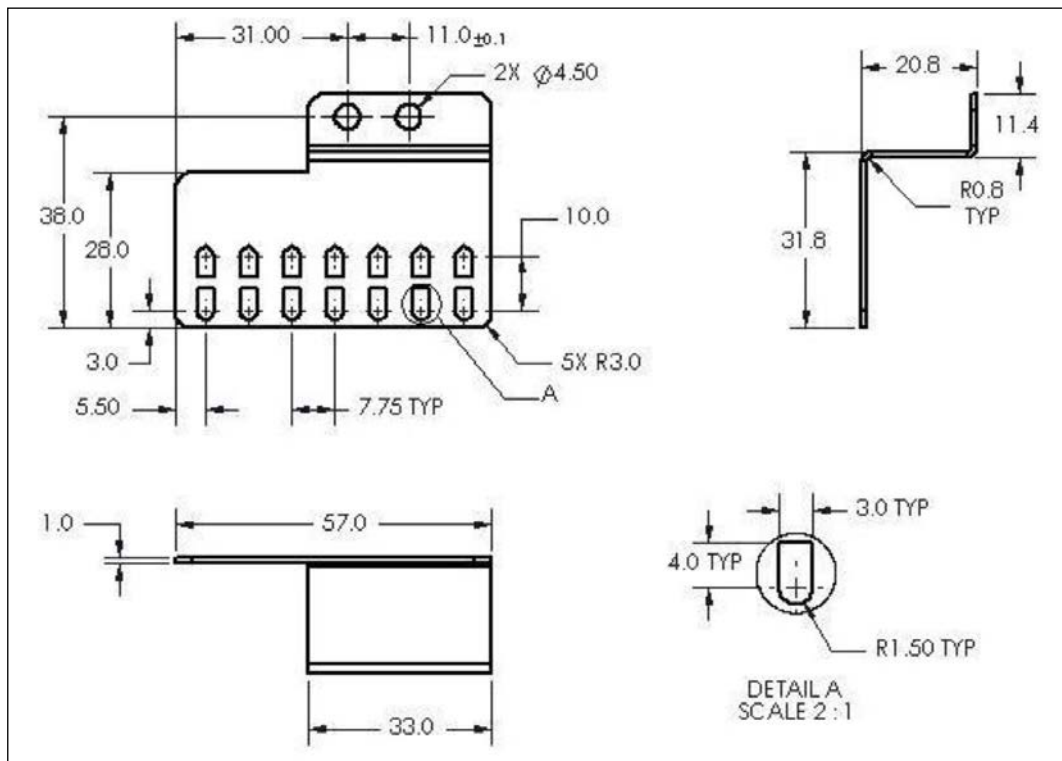

6.3.2 AKD-z-00307, AKD-z-00607, AKD-z-01207 Shield Plate

This shield plate (Item number 153-254001-00) is included for use with AKD-z-00307, AKD-z-00607, and AKD-z-01207 drives.

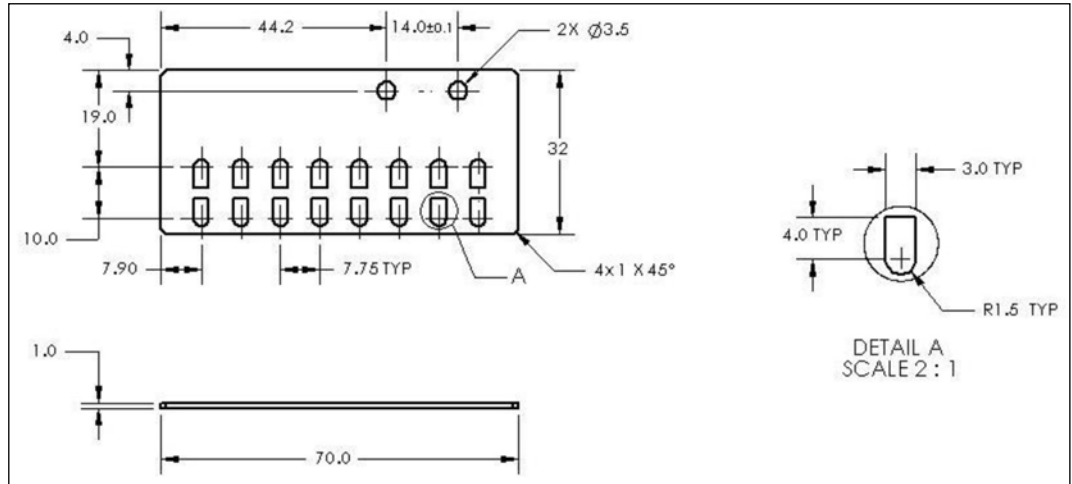

6.3.3 AKD-z-02407 Shield Plate

This shield plate (Item 153-255000-02) is included for use with the AKD-z-02407 drive.

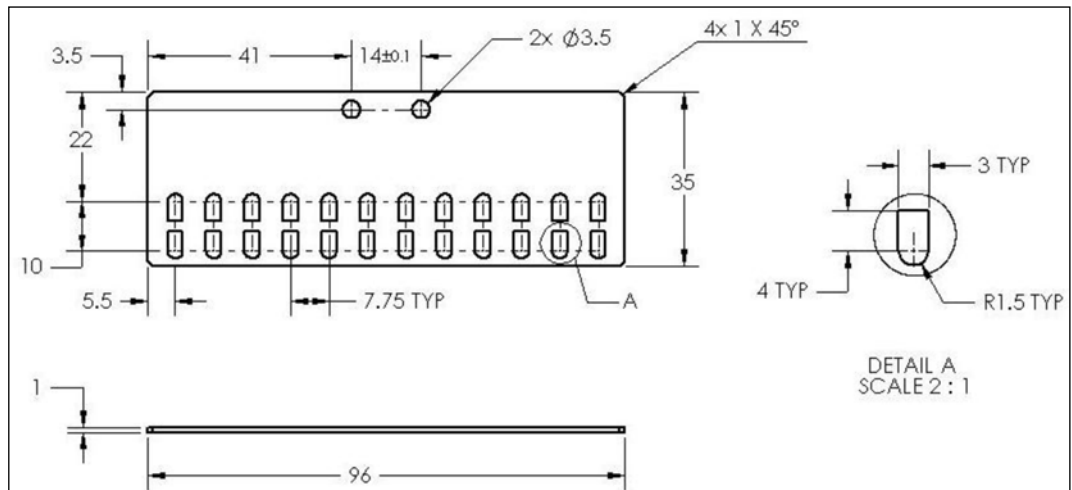

6.4 Connector Tool for AKD-N

Tool for screwing the union nut of the AKD-N connections.



Order Code

| Description | Order Codes |
|--|--------------|
| Tool for AKD-N servo drives to install connectors/cables | AKD-N-TOOL-A |

6.5 Sealing plugs for AKD-N connectors

The sealing plugs in the delivery package are screwed to unused AKD-N connectors to ensure the IP class for the machine environment. In case of lost plugs, you can order a set with 3 different plug sizes.



Order Code

| Description | Order Codes |
|---|---------------|
| AKD-N Sealing Plug Set, 4xM12, 2xM23, 2xM17 | AKD-N-S/P-Set |

6.6 AKD, AKD2G and S701 to S724 Shield Clamps (purchased separately)

AKD, AKD2G, S701 to 724 drives feature slots on the front panel for connecting additional shield clamps.

Recommended shield clamp:



In special cases, the cable shields can be routed to an additional busbar via shield clamps. The following shield clamp is recommended:

| Order Code | Item | Tension range |
|------------|------|---------------|
| DE-108248 | SK14 | 6-13 mm |

6.7 S748 to S772 Shield Clamps (purchased separately)

The shroud supplied with S748 to S772 drives features slots for the connection of additional shield clamps.

The clamps are included with the drive.

Recommend shield clamps:



| Manufacturer | Item | Tension range |
|------------------|----------------------|---------------|
| OBO (Bettermann) | BBS-Schelle Typ 2056 | 16-22 mm |
| OBO (Bettermann) | BBS-Schelle Typ 2056 | 28-34 mm |

6.8 External Shielding Busbar (purchased separately)



In special cases, the cable shields can be routed to an additional busbar via shield clamps. The following shield clamp is recommended:

| Manufacturer | Item | Tension range |
|--------------|------|---------------|
| Weidmüller | KLBÜ | 6-13 mm |

A possible scenario for setting up a busbar for the above shield clamps is described below.

1. Cut a busbar of the required length from a brass rail (cross-section 10 x 3 mm) and drill holes in it as indicated. All shield clamps required must fit between the drill holes.

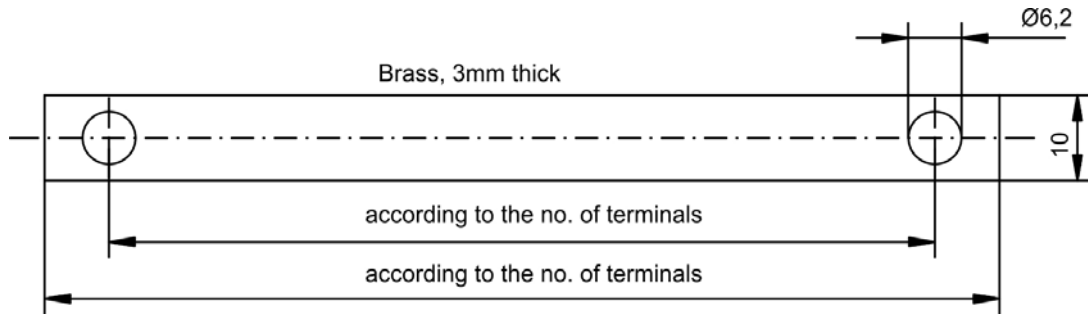

2. Squeeze together the coil spring and the supporting plate and push the busbar through the opening in the holder.

CAUTION

Risk of injury is present due to the spring force of the coil spring. Use pincers.

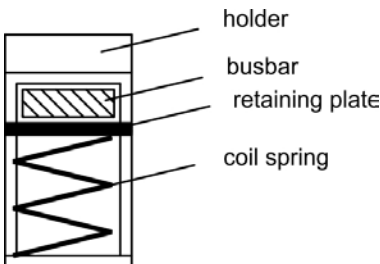

3. Mount the busbar with the shield clamps fitted on the assembly plate. Use either metal spacer bushes or screws with nuts and accessories to maintain a spacing of 50 mm. Earth the busbar using a single conductor with a cross-section of at least 2.5 mm².

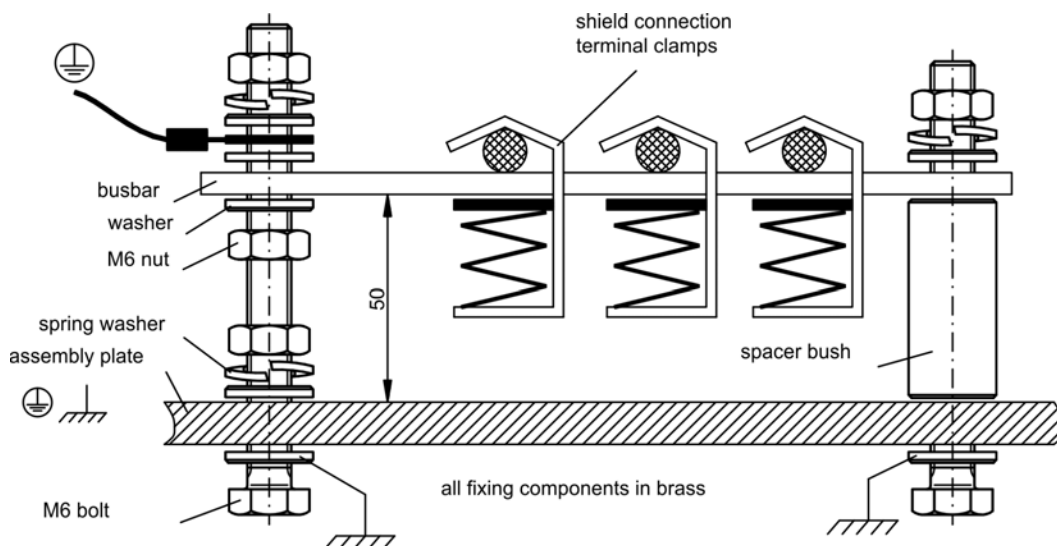

- Strip the external cable sheath to a length of approximately 30 mm, taking care not to damage the braided shield. Push the shield clamp up and route the cable to it via the busbar.

NOTICE

Make sure good contact exists between the shield clamp and the braided shield.

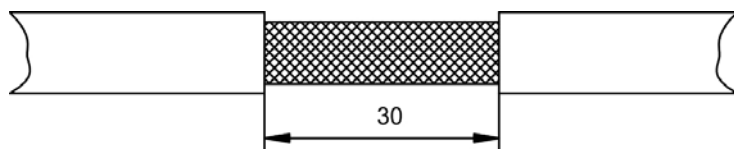

7 Mating Connectors and Adapters

7.1 Connectors for AKD-B/P/T/M

Mating connectors are part of delivery (except SubD and RJ types). For spare parts, see tables below.

Power Connectors

| Device | Description | Order Code |
|-----------------------------------|---|---|
| AKD-x00306/00606 | Mating connector X2, motor, with shield clamp SK14 | AKD-X2-SK14 |
| AKD-x02406, AKD-x00307...02407 | Mating connector X2, motor, with shield plate | AKD-X2+Shield-Kit |
| AKD-x00306/00606 | Mating connector X3, mains, DC-Bus, Regen Resistor | CON- AKDX3A-SL |
| AKD-x01206 | Mating connector X3, mains, DC-Bus, Regen Resistor | CON- AKDX3B-SL |
| AKD-x02406 | Mating connector X4, mains | CON- AKDX3C-SL |
| AKD-x02406, AKD-x00307...02407 | Mating connector X4, DC-Bus, Regen-R Mating connector X4 variant Y | CON- AKDX3C-S CON-AKDX3C-SL-Y |
| AKD-x04807 | Mating connector X4, mains | CON- AKD4807X4-SL |
| AKD-x04807 | Mating connector X14, DC-Bus Mating connector X14 variant Y | CON- AKD4807X14-SL CON-AKD4807X14-SL-Y |
| AKD-x04807 | Mating connector X3, Regen-R | CON- AKD4807X3-SL |

24 V Supply and STO Signals

| Device | Description | Order Code |
|-----------------------------|----------------------------------|------------------|
| AKD all variants, 3A to 24A | Mating connector X1, 24V and STO | CON-AKDX1-SL |
| AKD all variants, 48A | Mating connector X1, 24V and STO | CON-AKD4807X1-SL |

Digital I/O

| Device | Description | Order Code |
|------------------|----------------------------------|---------------|
| AKD all variants | Mating connector X7, I/O | CON-AKDX7-SL |
| | Mating connector X8, I/O | CON-AKDX8-SL |
| AKD-M | Mating connector X35, I/O | CON-AKDX35-SL |
| | Mating connector X36, I/O | CON-AKDX36-SL |
| Option IC | Mating connector X21, I/O Option | CON-AKDX21-SL |
| | Mating connector X22, I/O Option | CON-AKDX22-SL |
| | Mating connector X23, I/O Option | CON-AKDX23-SL |
| | Mating connector X24, I/O Option | CON-AKDX24-SL |

Feedback

| Device | Description | Order Code |
|------------------|--|----------------|
| AKD all variants | Connector kit with X10 male connector 15 pin high density, X9 female connector 9 pin, 2 housings, screws | AKD-X9+X10-Kit |

CAN

| Device | Description | Order Code |
|------------------|---------------------------|---------------------|
| AKD all variants | CAN Termination connector | AKD-CAN-Termination |
| AKD all variants | CAN RJ12->SubD9 adapter | AKD-CAN-RJ12-SubD9 |

7.2 Connectors for AKD-C

Mating connectors for X12, X13, X14, X15 and X16 are part of delivery. If a mating connector is lost or damaged, you can order the AKD-C Connector Kit.

Connector Kit

| Device | Description | Order Code |
|--------|--|----------------------|
| AKD-C | Connector Kit included mating connectors X12, X13, X14, X15 and X16 | AKD-C-CONKIT |
| AKD-C | Connector Kit included one mating connector with shield plate for X20A or X21A | CON-AKD-CX20/21A-SLA |

7.3 Connectors for AKD-N

We do not offer mating connectors for motor power, feedback, hybrid or string cables. If these connectors are damaged, a new Kollmorgen™ cable must be ordered.

Digital I/O connection

Kollmorgen™ recommends partly configured Phoenix SAC cables.

| Device | Description | Order Code |
|--------------------|--|-----------------------------------|
| AKD-N all variants | M12 mating connector for X3, 5 m cable, unconfigured wires | SAC-8P-M12MS (Phoenix Contact) |

STO connection

Kollmorgen™ recommends partly configured Phoenix SAC cables.

| Device | Description | Order Code |
|-------------|---|-----------------------------------|
| AKD-N-DS/DT | M12 mating connector for X6, 5 m cable, unconfigured wires, A coded | SAC-4P-M12MS (Phoenix Contact) |

Feldbus connection

Kollmorgen™ recommends partly configured Phoenix SAC cables.

| Device | Description | Order Code |
|-------------|---|--|
| AKD-N-DF/DG | M12 mating connector for X6, 5 m cable, unconfigured wires, D coded | SAC-4P-M12MSD/5,0 (Phoenix Contact) |

Jump-X5 connector for AKD-N-DS/DF with single cable connection

For sufficient voltage supply of the digital feedback systems HIPERFACE DSL or SFD3 connected to AKD-N-DS/DF connector X4, a dongle must be plugged to X5.

| Device | Description | Order Code |
|---------------------------|-------------------------------------|---------------|
| AKD-N-DS/DF, single cable | X5 mating connector with jumper 4-5 | AKD-N-JUMP-X5 |

7.4 Connectors for AKD2G

Mating connectors are part of delivery (except SubD and RJ types). For spare parts, see tables below.

Connector Kits

| Description | Order Code |
|--|--------------------------|
| X3, X10T, X21 connectors | AKD2G-CONKIT |
| X3, X10T, X21, X22 connectors | AKD2G-CONKIT+X22 |
| X3, X10T, X21, X22, X4, X5 connectors | AKD2G-CONKIT+X22+X4+X5 |
| X3T, X10T, X21 connectors | AKD2G-CONKIT-T |
| X3T, X10T, X21, X22 connectors | AKD2G-CONKIT+X22-T |
| X3T, X10T, X21, X22, X4, X5 connectors | AKD2G-CONKIT+X22+X4+X5-T |

Connectors

| Description | Order Code |
|--|-----------------|
| X1/X2 connector - hybrid power/feedback | AKD2G-CON-X1/X2 |
| X10T-connector - 24 VDC | AKD2G-CON-X10T |
| X21 connector - I/O | AKD2G-CON-X21 |
| X22 connector - I/O | AKD2G-CON-X22 |
| X3 connector - Mains/DC Link/Regen Resistor | AKD2G-CON-X3 |
| X3T-connector - Mains/DC Link/Regen Resistor | AKD2G-CON-X3T |
| X4 connector - second brake | AKD2G-CON-X4 |
| X5 connector - second feedback | AKD2G-CON-X5 |

7.5 Smart Feedback Adapter (SFA) for AKD2G

The AKD2G servo drive is optimized for single hybrid cable technology using HIPERFACE DSL or SFD3 feedback options. For using a conventional feedback, Kollmorgen™ offers the SFA.

The SFA converts conventional feedbacks into 2 wire feedback allowing a customer to connect the two wires into the X1, X2 or X5 connectors (shielded).

SFA can also be used for Emulated Encoder Output (EEO) and for electronic gearing. For X41 pinout and wire color coding, refer to the AKD2G Installation Manual.



- X41 Sub-D high density 15 pin, female
- 1 m shielded cable with 3 flying leads for connection to X1 or X2 or X5
- The cable shield is connected via shield wire to X5/1 or with cable ties to the X1/X2 shield plates (cut-off the unused shield wire).
- Input for electronic gearing
- Connected feedback must be set in WorkBench
- Use Kollmorgen™ feedback cables
- Output for encoder emulation (EEO3/EEO4)
- SFA dimensions (WxLxH): 55.6 x 88.7 x 21.2 mm

SFA Dimensions

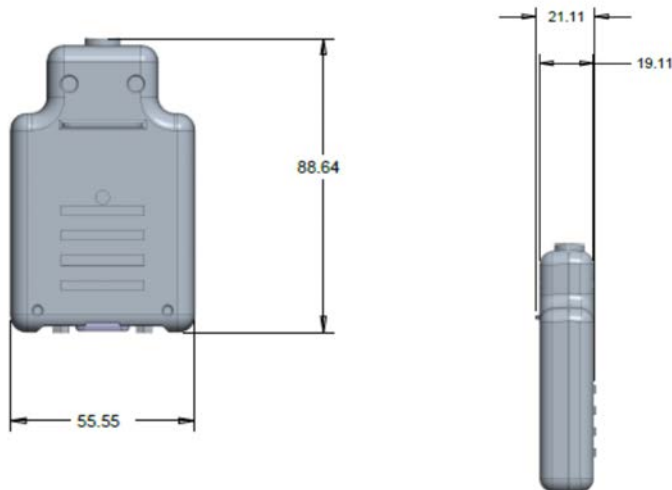

SFA with din rail



Order code

| Description | Order Code |
|--|---------------------|
| SFA – 1 meter cable | AKD2G-CON-SFA-000 |
| SFA with din rail clip – 1 meter cable | AKD2G-CON-SFA-000-D |

8 Mains Chokes

In special cases, if mains voltage is more than 3% asymmetrical, then the S748/772 drives must be used with a mains choke. Without this choke, an unfavorable combination of mains impedance and DC bus capacitance can result in an unloaded DC bus voltage of up to 800 V.

To reduce EMC, the chokes should be mounted isolated from the cabinet. Single conductors can be used for wiring; shielded cables are not required.

The purpose of mains choke is as follows:

- Prevents overloading of the semiconductors in the event of a rapid current rise during commutation.
- Prevents voltage dips in the mains voltage caused by commutation.
- Reduces current ripple in the DC link, which increases the service life of the DC link capacitors.

NOTICE

Several drives can be connected to one mains choke; the rated current of the mains choke must be greater than or at least equal to the total current of the connected drives.

8.1 Safety Instructions

⚠ WARNING

Power terminals can conduct hazardous voltage up to 10 minutes after the mains voltage has been disconnected. Before starting work on power terminals, check that the phase-to-earth and phase-to-phase voltages have de-energised.

⚠ WARNING

Due to the high earth leakage currents induced by the system, you should observe the requirements of EN 61800-5-1 (which is fixed installation, $\geq 10 \text{ mm}^2$ or double protective earth) when carrying out mounting and installation work.

⚠ CAUTION

You must read the instruction manuals for the drive/motor you are using in your application and observe the safety instructions they contain before starting mounting/installation work.

⚠ CAUTION

This manual is only valid in conjunction with the instruction manuals for the drive and motor you are using in your application.

NOTICE

A connection diagram appears in the drive instruction manual.

8.2 Type Assignment

| Drive | Mains Choke |
|---|--------------|
| AKD-x04807 (with asymmetrical mains >3% only) | 2% uk |
| AKD2G | Not required |
| S748 (with asymmetrical mains >3% only) | 2% uk |
| S772 (with asymmetrical mains >3% only) | 2% uk |
| S701 to 724 | Not required |

8.3 Order Codes

| Item | | uk | Order Codes | Comments |
|-------------------------|-----------------|----|-------------|--|
| Mains choke 3L0,24-50-2 | (0.24 mH, 50A) | 2% | DE-201476 | Can be used for S748/772 in case of asymmetric mains |
| Mains choke 3L0,2-75-2 | (0.20 mH, 75 A) | 2% | DE-201477 | Can be used for S748/772 in case of asymmetric mains |

8.4 Mains Choke 3L

A number of drives can be connected to the same mains choke; the rated current of the mains choke must be greater than or at least equal to the total current of the connected drives.

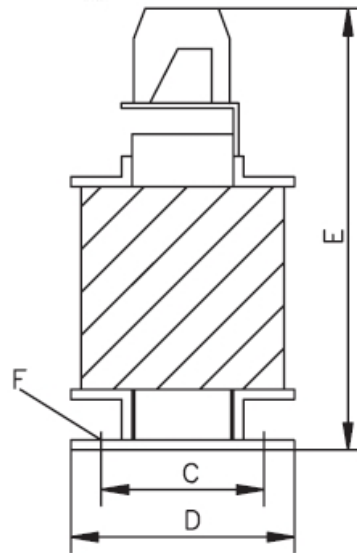
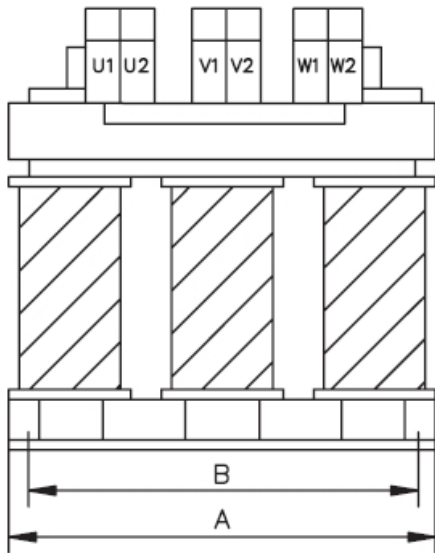
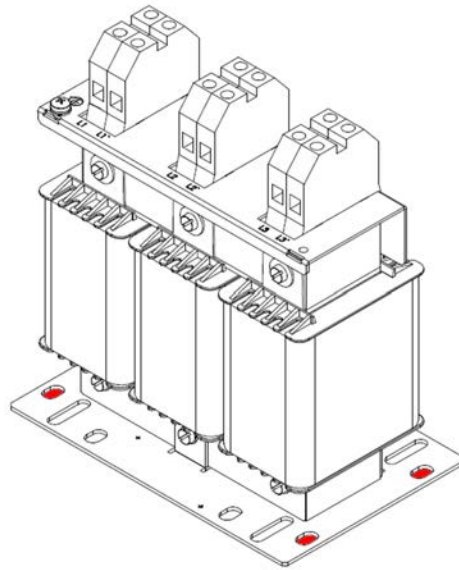
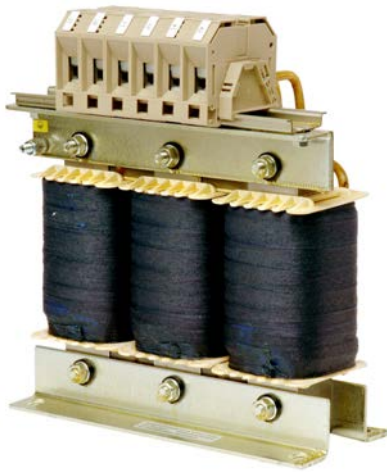

Technical Data

| Type | Inductivity [mH] | Nominal Current [A] | uk [%] | A [mm] | B [mm] | C [mm] | D [mm] | E [mm] | F [mm] | Terminals [mm ²] | Weight [kg] |
|-------------|------------------|---------------------|--------|--------|--------|--------|--------|--------|--------|------------------------------|-------------|
| 3L0,24-50-2 | 0.24 | 50 | 2 | 152.5 | 114.3 | 88.9 | 101.5 | 163 | 6.5 | 10 | 5.9 |
| 3L0,2-75-2 | 0.20 | 75 | 2 | 185 | 170 | 77 | 122 | 220 | 8x12 | 35 | 9.9 |

9 Mains Filters

AKD-P00306 to 02406 and AKD2G-xxx-6Vxx drives require an external mains filter. All other drives feature built-in mains filters (see the relevant instruction manual). The filtering effect of the mains filters can only be assured if the permissible throughput rating of the mains filters is not exceeded even on peak loading of the drives with I_{peak} .

The max. available throughput rating of the mains filter must be higher than the max. power consumption of the drives and higher than the maximum power consumption of the motors. More information can be found on Kollmorgen Developer Network in "[Mains Filter](#)".

9.1 Safety Instructions

⚠ CAUTION

You must read the instructions manual for the drive/motor you are using in your application and observe the safety instructions they contain before commencing mounting/installation work. This manual is only valid in conjunction with the instructions manual for the drive and motor you are using in your application.

⚠ WARNING

Power terminals are capable of conducting hazardous voltage up to 10 minutes after the mains voltage has been disconnected. Before starting work on power terminals, check that the phase-to-earth and phase-to-phase voltages have de-energized.

⚠ WARNING

Due to the high earth leakage currents induced by the system, you should observe the requirements of EN 61800-5-1 (e.g. fixed installation, $\geq 10 \text{ mm}^2$ or double protective earth) when carrying out mounting and installation work. A connection diagram appears in the drive installation manual.

9.2 Type Assignment

| Drive | Mains filter |
|-----------------------------------|--------------|
| AKD-x00306 to 02406 (120 to 240V) | 1NF, 3NF |
| AKD-x00307 to 02407 (240 to 480V) | Not required |
| AKD2G-xxx-6Vxx (120 to 240V) | 1NF, 3NF |
| AKD2G-xxx-7Vxx (240 to 480V) | Not required |
| S700 | Not required |

9.3 Order Codes

| Description | Order Code | Remarks |
|---------------------------------------|------------|---------------------------------|
| Mains filter 1NF-10 (230 VAC, 10A) | DE-201565 | 1~, 230 VAC, CE, UL |
| Mains filter 1NF-12 (230 VAC, 12A) | DE-201566 | 1~, 230 VAC, CE, UL |
| Mains filter 1NF-20B (125V/230V, 20A) | DE-201865 | 1~, IEC 230 VAC, UL 125 VAC, CE |
| Mains filter 1NF-25 (230 VAC, 25A) | DE-201568 | 1~, 230 VAC, CE, UL |
| Mains filter 3NF-07 (480 VAC, 07A) | DE-201569 | 3~, 480 VAC, CE, UL |
| Mains filter 3NF-16 (480 VAC, 16A) | DE-201570 | 3~, 480 VAC, CE, UL |
| Mains filter 3NF-30 (480 VAC, 30A) | DE-201571 | 3~, 480 VAC, CE, UL |
| Mains filter FN2090-6 | DE-202203 | 1~, 250 VAC, CE, UL |
| Mains filter FN2090-12 | DE-202204 | 1~, 250 VAC, CE, UL |
| Mains filters FN-3288-10 | DE-202205 | 3~, 530 VAC, CE, UL |
| Mains filters FN-3288-16 | DE-202206 | 3~, 530 VAC, CE, UL |

9.4 Mains filters FN2090



Observe the safety instructions.

For single-phase up to 240 VAC operation only.

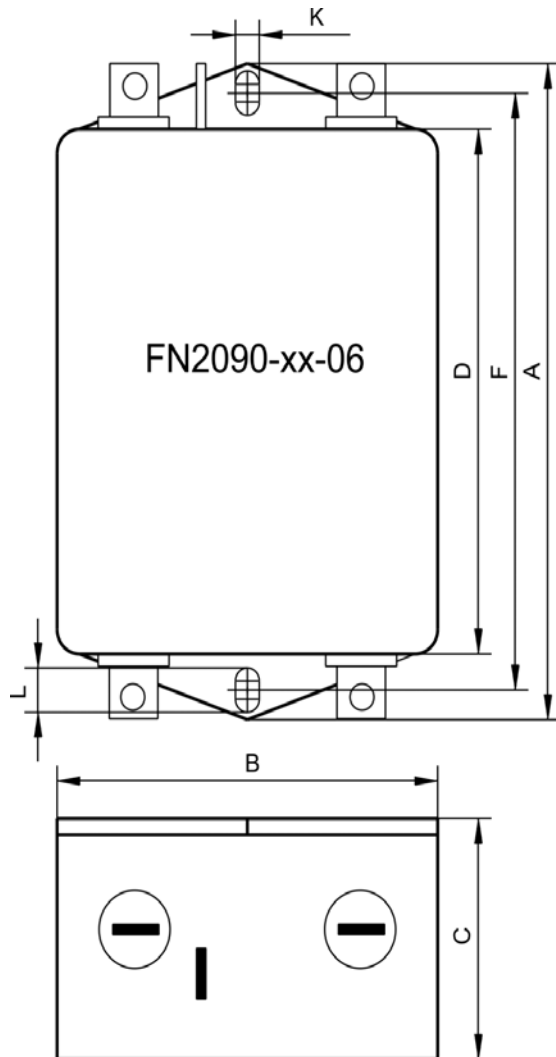

Technical Data

| Type | Nominal Current [A]* | A [mm] | B [mm] | C [mm] | D [mm] | F [mm] | K [mm] | L [mm] | Weight [kg] | Faston |
|--------------|----------------------|--------|--------|--------|--------|--------|--------|--------|-------------|-----------|
| FN2090-6-06 | 6 | 85 | 54 | 30,5 | 65 | 75 | 5.3 | 6.3 | 0.2 | 6.3 x 0.8 |
| FN2090-12-06 | 12 | 114 | 58 | 45.5 | 95 | 103 | 4.4 | 6 | 0.4 | 6.3 x 0.8 |

* at 50°C environment temperature

9.5 Mains filters 1NF-10...12

Observe the safety instructions.
For single-phase operation only.

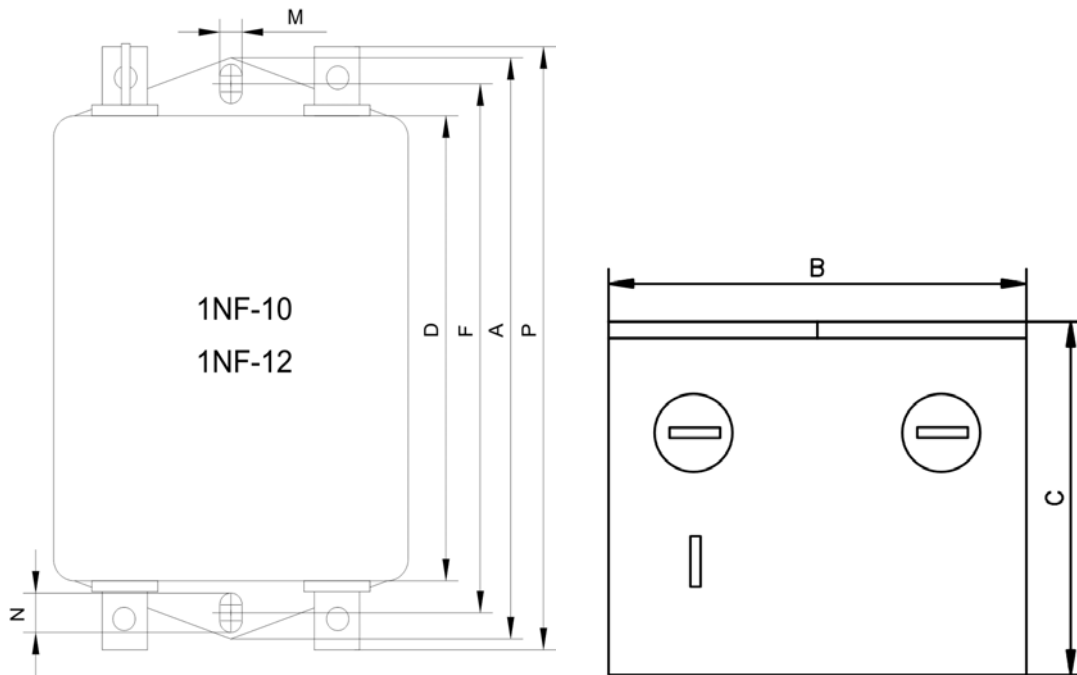

Technical Data

| Type | Nominal Current [A]* | Nominal Voltage [V] | A [mm] | B [mm] | C [mm] | D [mm] | F [mm] | M [mm] | N [mm] | P [mm] | Weight [kg] | Connection |
|--------|----------------------|---------------------|--------|--------|--------|--------|--------|--------|--------|--------|-------------|------------|
| 1NF-10 | 10 | 230 | 85 | 49 | 40.3 | 54 | 75 | 5.3 | 6.3 | 87 | 0.29 | Fast-on |
| 1NF-12 | 12 | 230 | 156 | 57.5 | 45.4 | 130.5 | 143 | 5.3 | 6 | 156 | 0.73 | Fast-on |

* at 40°C environment temperature

9.6 Mains filters FN3288



Observe the safety instructions.

For three-phase operation up to 480 VAC only.

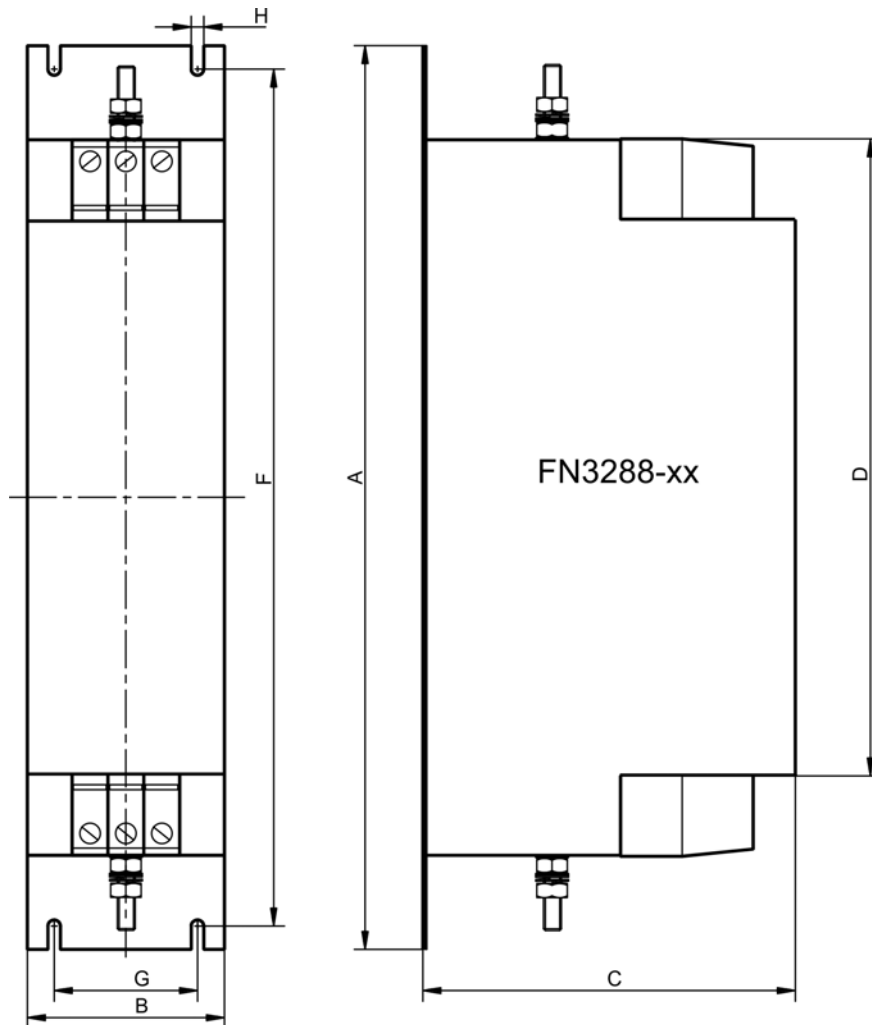

Technical Data

| Type | Nom. Current [A]* | A [mm] | B [mm] | C [mm] | D [mm] | F [mm] | G [mm] | H [mm] | Weight [kg] | Terminals | PE Bolt |
|-----------|-------------------|--------|--------|--------|--------|--------|--------|--------|-------------|-------------------------------------|--------------|
| FN3288-10 | 10 | 185 | 40 | 120 | 157 | 175 | 20 | 4.5 | 0.8 | 0.5-6mm ² , 1.0-1.2Nm | M5, 2.2Nm |
| FN3288-16 | 16 | 195 | 45 | 140 | 164 | 180 | 25 | 5.4 | 1.0 | | |

* at 50°C environment temperature

9.7 Mains filters 1NF-20B, 1NF-25

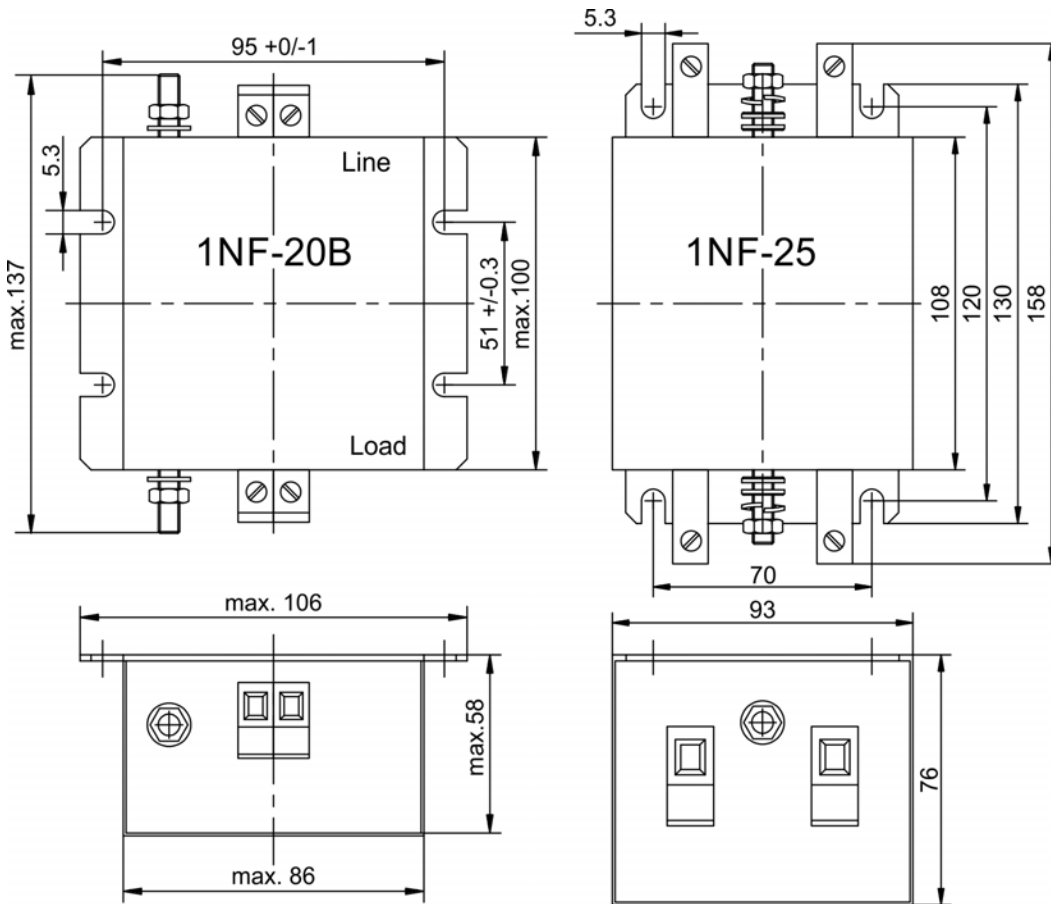

Technical Data

| Type | Nominal Current [A]* | Nominal Voltage | | Weight [kg] | Connection Phase Terminals | Connection PE |
|---------|----------------------|-----------------|--------|-------------|---|--------------------------------|
| | | IEC | UL/CSA | | | |
| 1NF-20B | 20 | 230V | 125V | 0.93 | Wires up to 4mm ² Torque 0.6 to 0.8 Nm | Bolt M 6 Torque 3.5 to 4 Nm |
| 1NF-25 | 25 | 230V | 230V | 0.7 | Wires up to 10mm ² Torque 1.5 to 1.8 Nm | |

* at 50°C environment temperature

9.8 Mains Filters 3NF-07...30

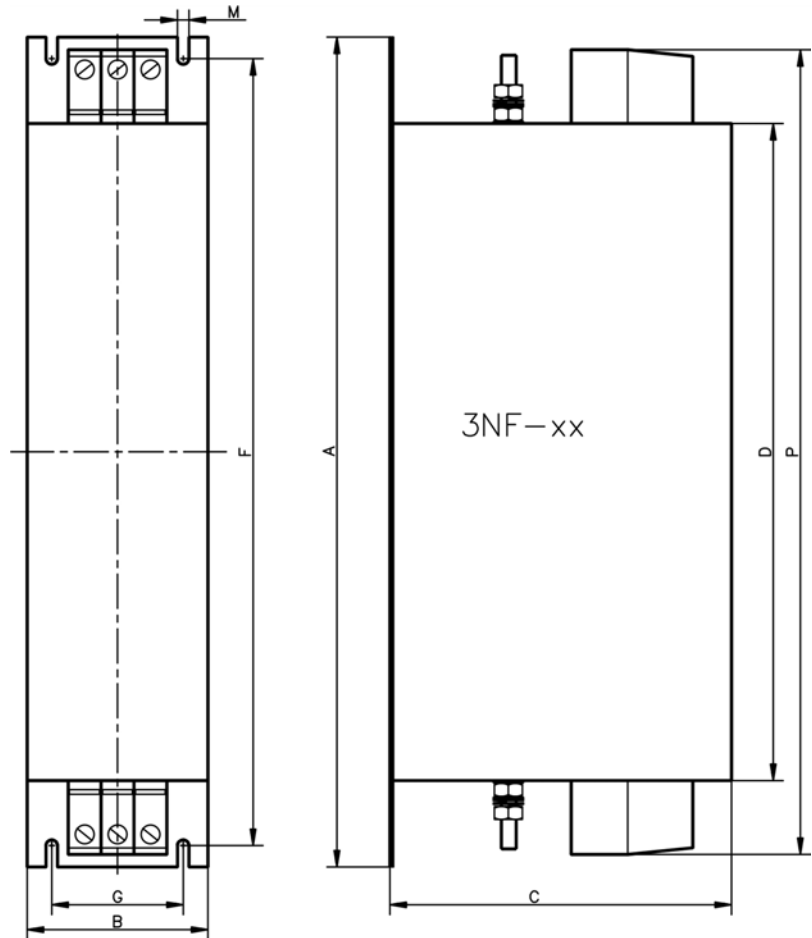

Technical Data

| Type | Nominal Current* | A [mm] | B [mm] | C [mm] | D [mm] | F [mm] | G [mm] | M [mm] | P [mm] | Weight [kg] | Terminals | PE Bolt |
|--------|------------------|--------|--------|--------|--------|--------|--------|--------|--------|-------------|---|--------------|
| 3NF-07 | 7 A | 190 | 40 | 70 | 160 | 180 | 20 | 4.5 | 180 | 0.5 | 4 mm ² , 0.7 to 0.8 Nm | M5, 2.2Nm |
| 3NF-16 | 16 A | 250 | 45 | 70 | 220 | 235 | 25 | 5.4 | 240 | 0.8 | | |
| 3NF-30 | 30 A | 270 | 50 | 85 | 240 | 255 | 30 | 5.4 | 260 | 1.2 | | |

* at 50°C environment temperature

10 Capacitor Modules

KCM (Kollmorgen™ Capacitor Modules) absorb energy generated by the motor when it is operating in generator mode. Normally, this energy is dissipated as waste through brake resistors. KCM feeds the energy stored back into the DC Bus link as and when it is required.

| | |
|--------------|---|
| KCM-S | Saves energy: The energy stored in the capacitor module during regenerative braking is available the next time acceleration happens. The module's inception voltage is calculated automatically during the first load cycles. |
| KCM-P | Power in spite of power failure: If the power supply fails, the module provides the drive with the stored energy that is required to bring the drive to a standstill in a controlled manner (this only applies to the power supply voltage; battery-back the 24 V supply separately). |
| KCM-E | Expansion module for both applications. Expansion modules are available in two capacitance classes. |

10.1 Important Notes

⚠ DANGER

DC Bus link terminals in servo systems carry high DC voltage of up to 900 V. Touching the terminals while they are carrying voltage is extremely dangerous. Switch off (disconnect) the line voltage. You must only work on the connections when the system is disconnected.

It can take over an hour for the modules to self-discharge. Check the state of charge with a measuring device that is suitable for a DC voltage of up to 1,000 V. When measuring a voltage of over 60 V between the DC+/DC- terminals or to ground, discharge the modules as described in the KCM Instructions Manual.

NOTICE

You must read the instructions manual for the drive / servomotor you are using in your application and observe the safety instructions they contain before commencing mounting/installation work.

Wiring diagram and more important notes concerning wiring can be found in the KCM instructions manual and in the instructions manual of the used drive.

10.2 Order Codes

The KCM modules may only be connected to drives with 400/480 V rated voltage.

| Type/Order Code | Remarks |
|-----------------|------------------------------|
| KCM-S200-0000 | Energy Saving Module, 1.6 kW |
| KCM-P200-0000 | Power Module, 2 kW |
| KCM-E200-0000 | Expansion Module 2 kW |
| KCM-E400-0000 | Expansion Module 4 kW |

Technical Data

| Type | Storage Capacity [Ws] | Rated supply voltage [V=] | Peak supply voltage [V=] | Power [kW] | Protection Class | Inception voltage [V=] | Weight' [kg] |
|----------|-----------------------|---------------------------|------------------------------|------------|------------------|------------------------|--------------|
| KCM-S200 | 1600 | max 850 VDC | max 950 VDC (30s in 6min) | 18 | IP20 | calculated | 6,9 |
| KCM-P200 | 2000 | | | | | 470 VDC | 6,9 |
| KCM-E200 | 2000 | | | | | - | 4,1 |
| KCM-E400 | 4000 | | | | | - | 6,2 |

10.3 KCM Module



Observe the safety instructions and in the instruction manual of the drive.

Permissible assembly type: Vertical, ground connections at the bottom. Other assembly positions are not permitted. Observe the required free space to next device. Ensure there is unobstructed convection for cooling purposes.

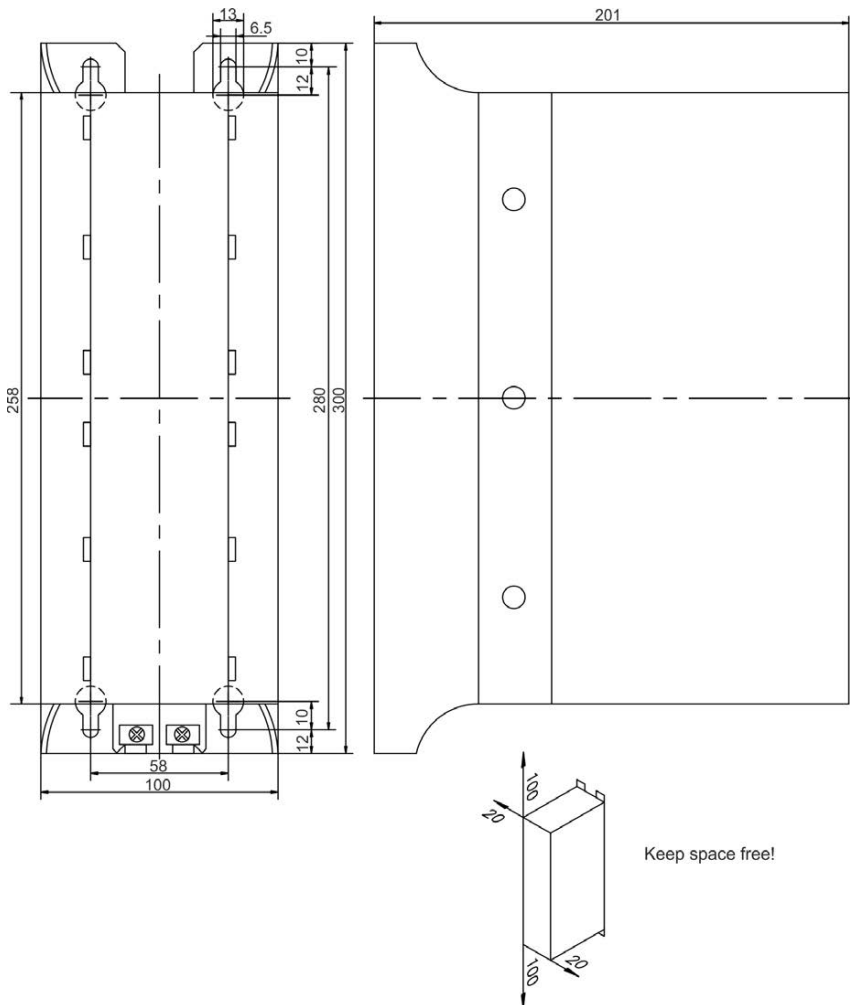

Technical Data

| Type | Storage Capacity [Ws] | Rated supply voltage [V=] | Peak supply voltage [V=] | Power [kW] | Protection Class | Inception voltage [V=] | Weight [kg] |
|----------|-----------------------|---------------------------|--------------------------|------------|------------------|------------------------|-------------|
| KCM-S200 | 1600 | max 850 VDC | max 950VDC (30s in 6min) | 18 | IP20 | calculated | 6.9 |
| KCM-P200 | 2000 | | | | | 470 VDC | 6.9 |
| KCM-E200 | 2000 | | | | | - | 4.1 |
| KCM-E400 | 4000 | | | | | - | 6.2 |

10.4 External Regen Resistor BAFP(U)



Observe the instructions in [Important Notes](#) and in the instruction manual of the drive.

Permissible assembly type: Vertical, ground connections at the bottom. Other assembly positions are not permitted. Observe the required free space to next device. Ensure there is unobstructed convection for cooling purposes.

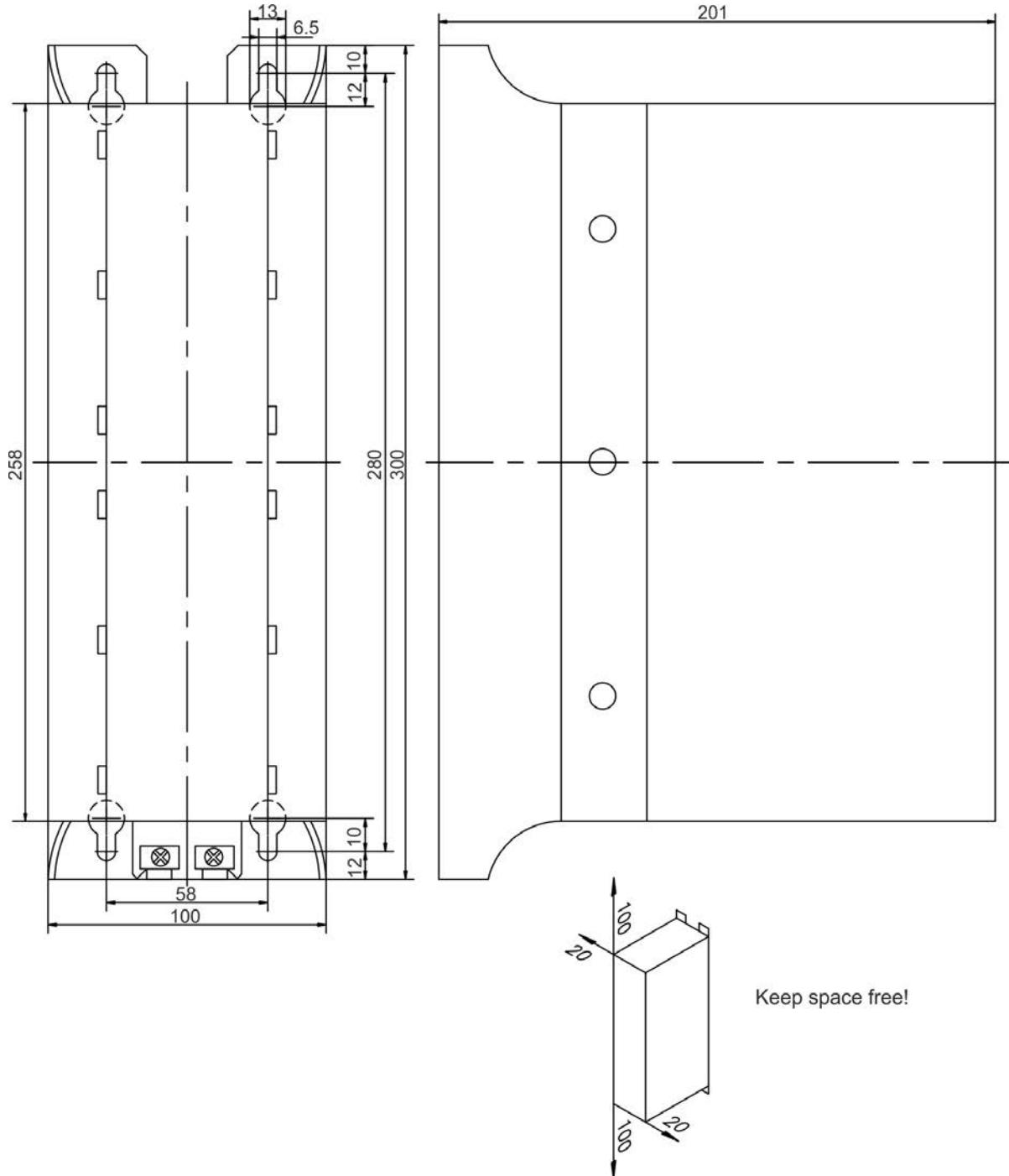

11 Brake/Regeneration Resistors

During braking with the aid of the motor, energy is fed back into the drive. This energy is dissipated as heat in the regeneration resistor (referred to as a brake resistor when used with an S700 drive). The regen resistor is switched on by the brake circuit. Different resistance values must be used depending on the drive. All regen resistors meet the requirements of CE directives and are UL-registered. Regen resistor requirements for Kollmorgen™ servo systems can be calculated using the [Motioneering sizing and selection tool](#).

11.1 Safety Instructions

⚠ CAUTION

- You must read the instruction manuals for the drive and motor that you are using in your application and observe the safety instructions they contain before starting mounting/installation work.
- This manual is only valid in conjunction with the instruction manuals for the drive and motor you are using in your application.
- Danger of burn. Mount only in switchgear cabinets, observe installation clearances, provide the requisite conditions for unobstructed convection for cooling. As Regen resistors can heat up to temperatures in excess of 250°C, use temperature-resistant components in the vicinity of the resistor.
- Observe allowed mounting positions (see dimension drawings). The connection terminals must never be in the vicinity area of hot air.
- In case of insufficient cooling or false mounting the resistor or the surrounding devices could be overheated or damaged.
- A connection diagram appears in the drive's instructions manual.

NOTICE

For best results, the following conditions must be provided for regen resistors:

- Unobstructed cooling air
- Unobstructed diversion of warmed air
- Rated data with maximum ambient temperature 40°C, in case of ambient temperature higher than 40°C, power must be reduced by 4% per 10K temperature rise.

11.2 Type Assignment

| Drive | Regen resistor | Resistance/Ohm |
|-------------|-----------------------|----------------|
| AKD-x00306 | BAFP(U)/BAR(U)/BAS(U) | 33 |
| AKD-x00606 | BAFP(U)/BAR(U)/BAS(U) | 33 |
| AKD-x01206 | BAFP(U)/BAR(U)/BAS(U) | 15 |
| AKD-x02406 | BAR(U)/BAS(U) | 15 |
| AKD-x00307 | BAR(U)/BAS(U) | 33 |
| AKD-x00607 | BAR(U)/BAS(U) | 33 |
| AKD-x01207 | BAR(U)/BAS(U) | 33 |
| AKD-x02407 | BAR(U)/BAS(U) | 23 |
| AKD-x04807 | BAS(U) | 10 |
| AKD-C | BAR(U)/BAS(U) | 33 |
| AKD2G | BAFP(U)/BAR(U)/BAS(U) | 33 |
| S701 to 712 | BAR(U) | 33 |
| S724 | BAR(U)/BAS(U) | 23 |
| S748 | BAS(U) | 15 |
| S772 | BAS(U) | 10 |

11.3 Order Codes

| Description | Drive | Resistance [Ω] | Rated Power [W] | Max. Power [W] | Order code |
|-------------------------------|---|----------------|-----------------|----------------|-------------|
| Regen resistor BAS(U) 2000-10 | S772 | 10 | 2000 | 3200 | BAS-2000-10 |
| Regen resistor BAS(U) 3000-10 | | 10 | 3000 | 4800 | BAS-3000-10 |
| Regen resistor BAS(U) 6000-10 | | 10 | 6000 | 9600 | BAS-6000-10 |
| Regen resistor BAR(U) 500-15 | AKD-x01206, AKD-x02406, S748, AKD2G-SPx-6V12 | 15 | 500 | 800 | BAR-500-15 |
| Regen resistor BAR(U) 1000-15 | | 15 | 1000 | 1600 | BAR-1000-15 |
| Regen resistor BAS(U) 2000-15 | | 15 | 2000 | 3200 | BAS-2000-15 |
| Regen resistor BAS(U) 3000-15 | | 15 | 3000 | 4800 | BAS-3000-15 |
| Regen resistor BAS(U) 6000-15 | | 15 | 6000 | 9600 | BAS-6000-15 |
| Regen resistor BAR(U) 600-23 | AKD-P02407, S724 | 23 | 600 | 960 | BAR-600-23 |
| Regen resistor BAR(U) 1000-23 | | 23 | 1000 | 1600 | BAR-1000-23 |
| Regen resistor BAS(U) 2000-23 | | 23 | 2000 | 3200 | BAS-2000-23 |
| Regen resistor BAS(U) 3000-23 | | 23 | 3000 | 4800 | BAS-3000-23 |
| Regen resistor BAS(U) 4000-23 | | 23 | 4000 | 6400 | BAS-4000-23 |
| Regen resistor BAFP(U) 100-33 | AKD-x00306 to x00606, AKD-x00307 to x01207, S701 to S712, AKD2G-SPx-6V03, AKD2G-SPx-6V06, AKD2G-SPx-7V03 to AKD2G-SPx-7V12 | 33 | 100 | 160 | BAFP-100-33 |
| Regen resistor BAFP(U) 200-33 | | 33 | 200 | 320 | BAFP-200-33 |
| Regen resistor BAR(U) 250-33 | | 33 | 250 | 400 | BAR-250-33 |
| Regen resistor BAR(U) 500-33 | | 33 | 500 | 800 | BAR-500-33 |
| Regen resistor BAR(U) 1500-33 | | 33 | 1500 | 2400 | BAR-1500-33 |
| Regen resistor BAS(U) 3000-33 | | 33 | 3000 | 4800 | BAS-3000-33 |

11.4 External Regen Resistor BAFF(U)



Protection class: IP40



CAUTION

- Surface temperature can exceed 250°C.
- Make sure that the necessary space is kept clear.
- Do not mount on combustible surfaces.

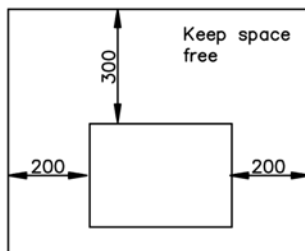
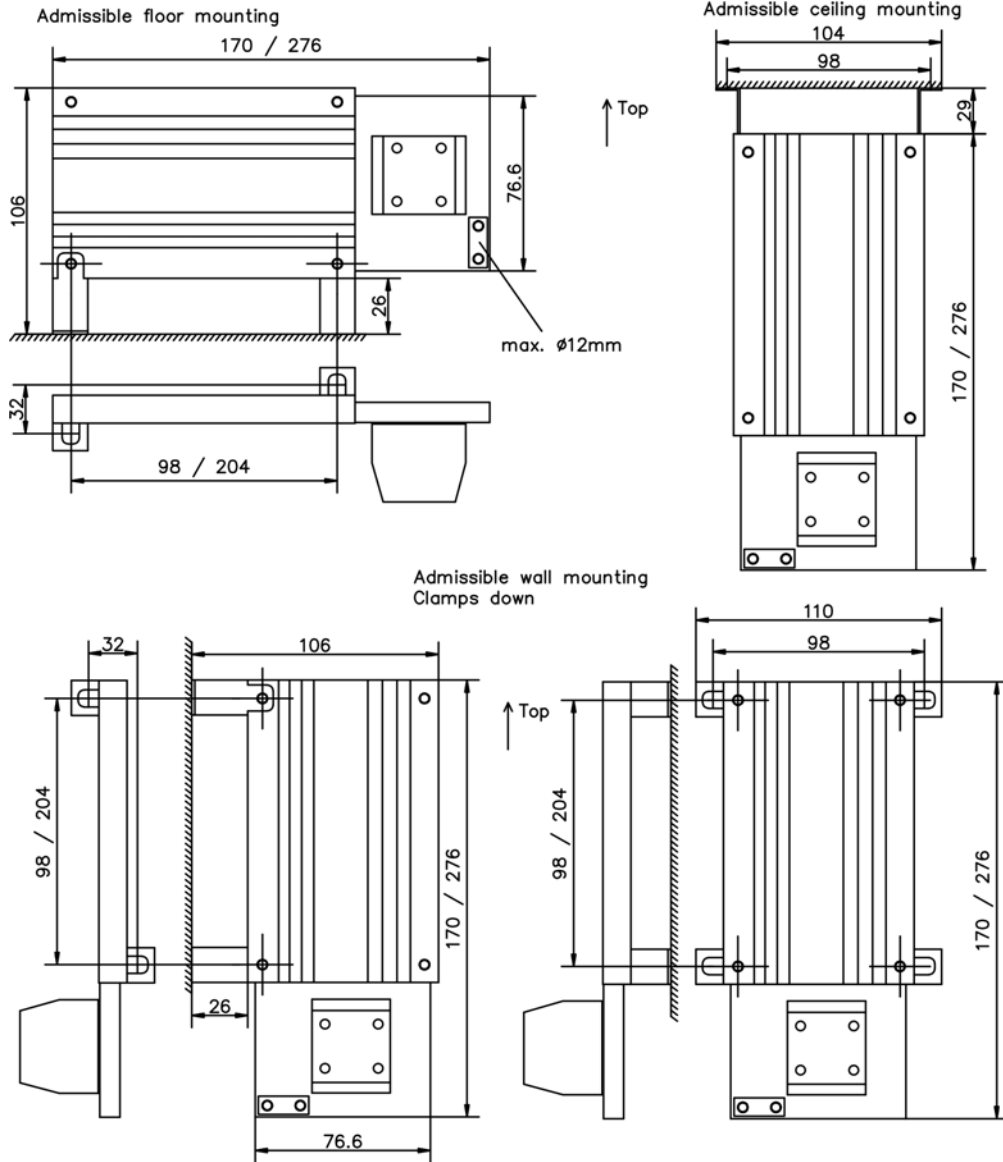

| Typ | R | Length | Power | Weight |
|----------------|----------|--------|-------|--------|
| | Ω | mm | W | Kg |
| BAFF(U) 100-33 | 33 | 170 | 100 | 0,3 |
| BAFF(U) 200-33 | 33 | 276 | 200 | 0,55 |

Other types of mounting are not admitted !

11.5 External Regen Resistor BAR(U)

Protection class: IP20



CAUTION

- Surface temperature can exceed 250°C.
- Make sure that the necessary space is kept clear.
- Do not mount on combustible surfaces.

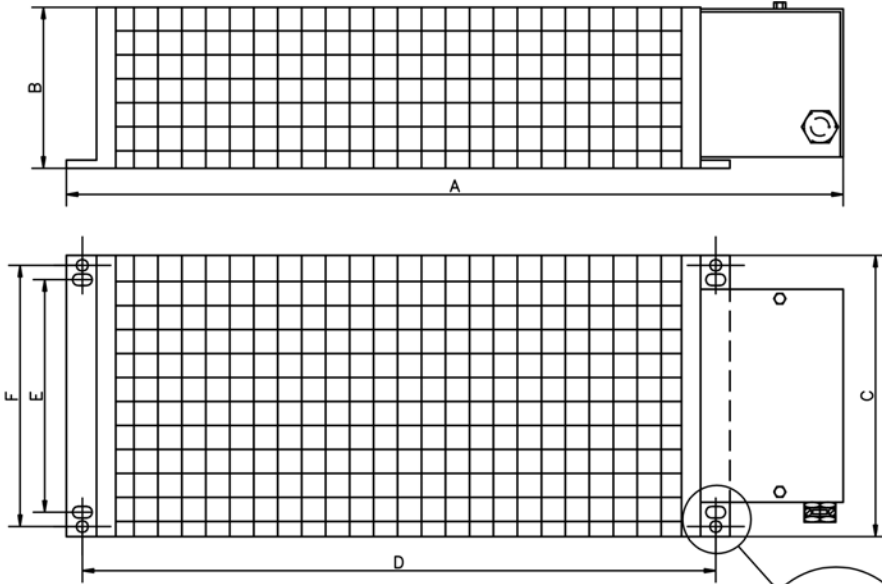

| Type | R Ω | Power W | A mm | B mm | C mm | D mm | E mm | F mm | weight Kg |
|-------------|--------|------------|---------|---------|---------|---------|---------|---------|--------------|
| BAR(U) 500 | 15 | 500 | 549 | 120 | 92 | 430 | 64 | 80 | 3 |
| BAR(U) 1000 | 15 | 1000 | 749 | 120 | 92 | 630 | 64 | 80 | 4 |
| BAR(U) 600 | 23 | 600 | 549 | 120 | 92 | 430 | 64 | 80 | 3 |
| BAR(U) 1000 | 23 | 1000 | 749 | 120 | 92 | 630 | 64 | 80 | 4 |
| BAR(U) 250 | 33 | 250 | 349 | 120 | 92 | 230 | 64 | 80 | 2 |
| BAR(U) 500 | 33 | 500 | 549 | 120 | 92 | 430 | 64 | 80 | 3 |
| BAR(U) 1500 | 33 | 1500 | 649 | 120 | 185 | 530 | - | 150 | 5,8 |
| BAR(U) 300 | 66 | 300 | 349 | 120 | 92 | 226 | 64 | 80 | 1,5 |
| BAR(U) 600 | 66 | 600 | 549 | 120 | 92 | 426 | 64 | 80 | 2,3 |
| BAR(U) 1000 | 66 | 1000 | 749 | 120 | 92 | 626 | 64 | 80 | 3,4 |
| BAR(U) 300 | 91 | 300 | 349 | 120 | 92 | 226 | 64 | 80 | 1,5 |
| BAR(U) 600 | 91 | 600 | 549 | 120 | 92 | 426 | 64 | 80 | 2,3 |
| BAR(U) 1000 | 91 | 1000 | 749 | 120 | 92 | 626 | 64 | 80 | 3,4 |

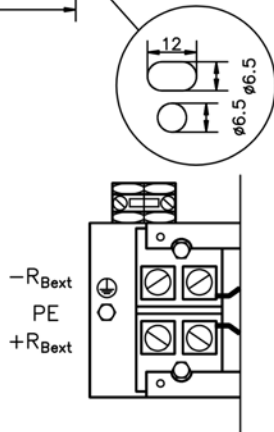

±10%, Temperaturdrift ca. 1%
Kalt ca. +8%, 320°C ca. -7%

Admissible floor mounting

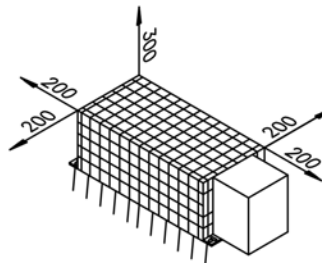

Admissible wall mounting
Clamps down

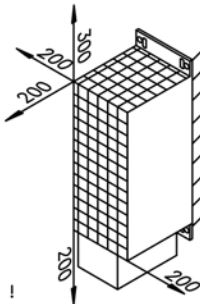

Other types of mounting are not admitted !

11.6 External Regen Resistor BAS(U)

Protection class: IP20



CAUTION

- Surface temperature can exceed 250°C.
- Make sure that the necessary space is kept clear.
- Do not mount on combustible surfaces.

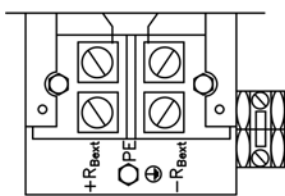
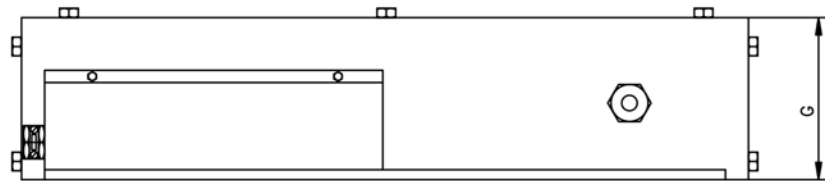
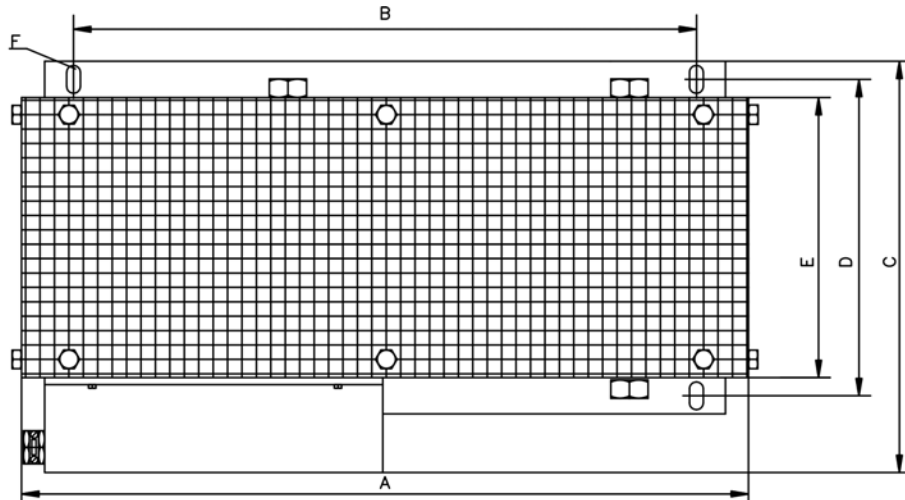

Admissible floor mounting

Admissible wall mounting
Clamps down

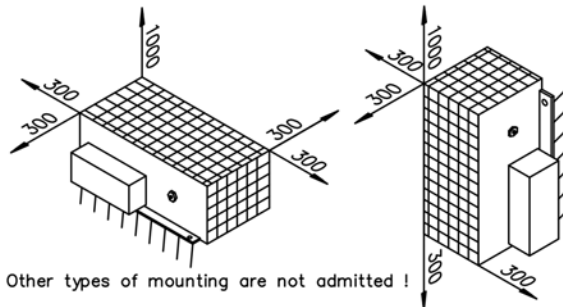

±10%, Temperaturdrift ca. 1%
Kalt ca. +8%, 320°C ca. -7%

Other types of mounting are not admitted !

| | R | Rated power | A | B | C | D | E | F | G | weight |
|---------------|----|-------------|-----|-----|-----|-----|-----|-------|-----|--------|
| | Ω | W | mm | mm | mm | mm | mm | mm | mm | Kg |
| BAS(U)2000-10 | 10 | 2000 | 490 | 380 | 255 | 170 | 150 | ∅10,5 | 260 | 7 |
| BAS(U)3000-10 | 10 | 3000 | 490 | 380 | 355 | 270 | 250 | ∅10,5 | 260 | 8 |
| BAS(U)6000-10 | 10 | 6000 | 490 | 380 | 455 | 370 | 350 | ∅10,5 | 260 | 11 |
| BAS(U)2000-15 | 15 | 2000 | 490 | 380 | 255 | 170 | 150 | ∅10,5 | 260 | 7 |
| BAS(U)3000-15 | 15 | 3000 | 490 | 380 | 355 | 270 | 250 | ∅10,5 | 260 | 8 |
| BAS(U)6000-15 | 15 | 6000 | 490 | 380 | 455 | 370 | 350 | ∅10,5 | 260 | 11 |
| BAS(U)2000-23 | 23 | 2000 | 490 | 380 | 255 | 170 | 150 | ∅10,5 | 260 | 7 |
| BAS(U)3000-23 | 23 | 3000 | 490 | 380 | 355 | 270 | 250 | ∅10,5 | 260 | 8 |
| BAS(U)4000-23 | 23 | 4000 | 490 | 380 | 355 | 270 | 250 | ∅10,5 | 260 | 9 |
| BAS(U)3000-33 | 33 | 3000 | 490 | 380 | 355 | 270 | 250 | ∅10,5 | 260 | 8 |

12 Motor Chokes

12.1 Shielded Motor Cables

For electromagnetic compatibility, the motor must be supplied with power using a shielded cable. The structure of a cable with 100% shielding and the capacity equivalent circuit diagram (to earth) are shown below.

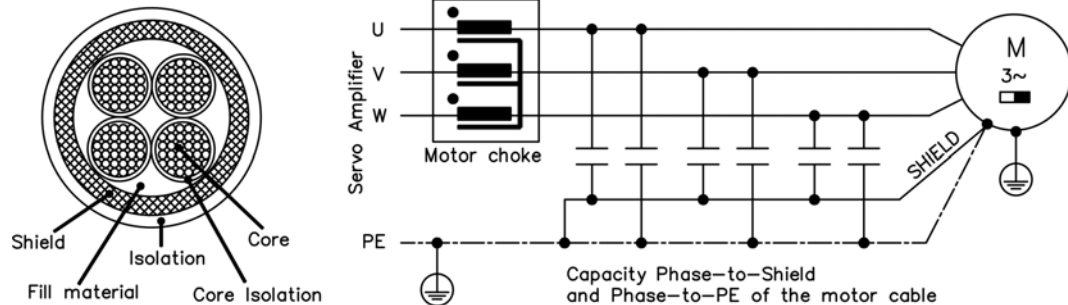

Why use motor chokes?

- To compensate for high capacitive charge/discharge currents typical of shielded motor cables approximately 25 m and longer.
- To reduce current alternation noise in the motor.
- To reduce current ripple in the motor.

The digital drives' high switching frequencies and steep switching edges give rise to the transfer of capacitive currents to the shield by the three phases (U, V, W). These currents flow from the shield to earth. Depending on the cable length and cable capacity, this can lead to the generation of shield currents with peak values of up to 20 A. These shield currents place a load on the drives and motor and, on large systems, lead to shifts in potential which can damage other components. This effect is evident in particular on systems with multiple drives operating in parallel on the same mains filter. The motor chokes slow down the rate of rise of the motor current, thereby reducing the current transferred to the shield.

Why is the cross-section of the motor cable important?

Motor cables longer than 50 m with a small cross-section (such as 4x1.0mm²) and therefore a higher equivalent resistance are able to reduce the oscillation tendency of the LCR oscillating circuit (drive/choke/cable/motor). This cross-section can also be advantageous for cable lengths shorter than 50 m if the cable capacity and motor inductance are very high. However, the current loading of the cable must always be within the limits specified by industry standards.

12.2 Safety Instructions

⚠ CAUTION

- Before starting mounting/installation work, you must read and observe the instruction manuals and the safety instructions that they contain for the drive and motor that you are using in your application.
- This manual is only valid in conjunction with the instruction manuals for the drive and motor you are using in your application.
- Mount the motor choke on a conductive earthed plate in the switchgear cabinet.
- The choke can become hot during operation (rising to temperatures in excess of 80°C). Therefore, you should make sure that the choke is mounted a sufficient distance away from neighboring components.
- Provide the requisite conditions for unobstructed convection to cool the choke.
- A connection diagram appears in the drive instructions manual.
- If the motor cable is longer than 25 m, then the motor choke is wired into the cable close to the amplifier. When laying the motor cable, allow about 400 mm for the connection to the choke.

12.3 Type Assignment

| Drive* | Motor choke | Approvals | Condition |
|---------------------------|--------------|-----------|-------------------|
| AKD-x003x to AKD-x006x | 3YLN-06 | CE, UL | Motor cable > 25m |
| AKD-x012x | 3YLN-14 | CE, UL | Motor cable > 25m |
| AKD-x024x | 3YLN-24 | CE, UL | Motor cable > 25m |
| AKD2G-xxx-xV003 to -xV006 | 3YLN-06 | CE, UL | Motor cable > 50m |
| AKD2G-xxx-xV012 | 3YLN-14 | CE, UL | Motor cable > 50m |
| S701 to 724 | 3YLN-xx | CE, UL | Motor cable > 25m |
| S748/772 | Not required | | |

*AKD part numbers indicate continuous current rating (-003 is 3 A, -012 is 12 A, etc).

12.4 Motor Choke 3YLN-xx

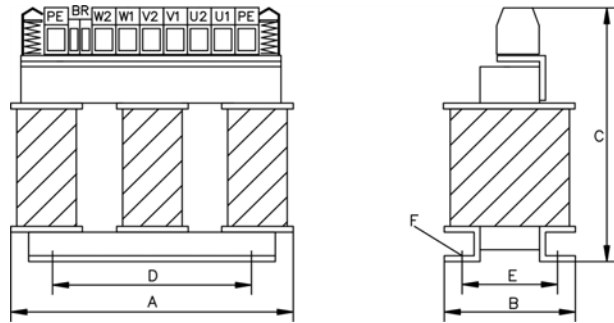

Technical Data

| Rated Data | Symbol | Units | 3YLN-06 | 3YLN-14 | 3YLN-20 | 3YLN-24 |
|---------------------------------------|------------|---------|-----------|---------|---------|---------|
| Rated current | I_{0rms} | A | 6 | 14 | 20 | 24 |
| Rated voltage | U_{nom} | V | 480 | | | |
| Rated frequency | f_{nom} | Hz | 0 to 150 | | | |
| Max. frequency | f_{max} | kHz | 8 | | | |
| Inductivity | L | μH | 900 | 900 | 450 | 450 |
| Power loss | P | W | 12 | 19.4 | 22.3 | 23.2 |
| Protection class | - | - | IP00 | | | |
| Temperature class | - | - | F | | | |
| Operation class | - | - | S1 | | | |
| Weight | G | kg | 4.5 | 10 | 10 | 10 |
| Cable diameter (Shield clamp) | - | mm | 4 to 13.5 | | | |
| Wiring cross section max. (Terminals) | - | mm^2 | 10 | 16 | 16 | 16 |
| Width | A | mm | 155 | 190 | 190 | 190 |
| Depth | B | mm | 90 | 125 | 125 | 125 |
| Height | C | mm | 195 | 230 | 230 | 230 |
| Mounting hole distance | D | mm | 130 | 170 | 170 | 170 |
| Mounting hole distance | E | mm | 56.5 | 78 | 78 | 78 |
| Mounting screws | F | - | 4xM6 | 4xM6 | 4xM6 | 4xM6 |

13 Cables

This chapter provides cable information for AKD and S700 series servo drives. For AKD2G cable information, see [Kollmorgen 2G Cable Guide on the Kollmorgen™ website](#).

13.1 PC Connection

The AKD drive is connected to a PC or to a switch/hub by a standard net cable with RJ45 connectors.

The S700 drive series is connected to a PC using a serial RS232-SubD9 cable.

13.2 Kollmorgen™ Ethernet Cables

PUR jacketed CAT5e cables, pre-terminated with RJ45 connectors.

| Description | Order code |
|--|---------------|
| 0.17 meter pre-terminated patch cable | ENCP-0017-000 |
| 0.26 meter pre-terminated patch cable | ENCP-0026-000 |
| 0.50 meter pre-terminated patch cable | ENCP-0050-000 |
| 1 meter pre-terminated patch cable | ENCP-0100-000 |
| 2 meter pre-terminated patch cable | ENCP-0200-000 |
| 3 meter pre-terminated patch cable | ENCP-0300-000 |
| 4 meter pre-terminated patch cable | ENCP-0400-000 |
| 5 meter pre-terminated patch cable | ENCP-0500-000 |
| 10 meter pre-terminated patch cable | ENCP-1000-000 |
| Unterminated cable per 10 meter increment (min 30 meters) | ENCU-xxxx-000 |
| Connector kit for ENCU-xxxx-000 unterminated cable (one termination per kit) | ENCU-KIT-000 |

Technical Data

| ENCP-xxxx-xxx (Kollmorgen™ Ethernet Cables) | |
|---|---|
| Cross-section | 4 x 2 x AWG26/7 ... 4 x 2 x 0.128 mm ² |
| Cable sheath material | PUR |
| Color | Green (RAL 6018) |
| Line configuration | SF/UTP |
| Diameter | sheath: typ. 5.9 mm ± 0.2 mm |
| Bending radius | > 5 x diameter |
| Category/class | CAT5e, class D |
| Operating/installation temperature | -40... +75 °C/-10 ... +60 °C |
| Insertion cycles | min. 750 |

13.3 AKD Performance Cables**13.3.1 Hybrid Cables**

Hybrid cables offer a single connection point on the motor for both feedback and power. Feedback options for this connection type are:

- SFD GEN3 (Single-turn absolute, CA option)
- HIPERFACE® DSL (Single-turn absolute, GE option)
- HIPERFACE DSL (Multi-turn option, GF option)

Washdown versions of this cable are also available.

13.3.2 AKD Hybrid Cables by Motor Type

| Motor | Hybrid Cable ¹ option for 240V drives (AKD-xxxx06xxxx) | Hybrid Cable ¹ option for 480V drives (AKD-xxxx07xxxx) |
|----------------------------|---|---|
| AKM < 12 A | CCJ1A2-015 | CCJ2A2-015 |
| 12 A ≤ AKM < 20 A | CCJ2A2-025 | CCJ2A2-025 |
| Washdown AKM < 12 A | WCJ1A1-015 | WCJ2A1-015 |
| 12 A ≤ Washdown AKM < 20 A | WCJ2A1-025 | WCJ2A1-025 |

¹Hybrid cables support SFD GEN 3, Single-turn and Multi-turn HIPERFACE DSL.

13.3.3 Dual Cables

Dual cables are used to separate power and feedback. Options included in this catalog support:

- HIPERFACE (Single-turn absolute, GJ option)
- HIPERFACE (Multi-turn absolute, GK option)
- EnDat (Single-turn, LA option)
- EnDat (Multi-turn, LB option)
- BiSS (Single-turn absolute, AA option)
- BiSS (Multi-turn absolute, AB option)

| Motor | Power Cable | Power Cable with Brake | SFD | EnDat 2.2, 01 & BiSS |
|--------------------|-------------|------------------------|------------|----------------------|
| AKM < 12 A | CP-507CCAN | CP-507CDAN | CP-507CDAN | CF-SB7374N |
| 12 A ≤ AKM < 20 A | CP-507DCAN | CP-507DDAN | CP-507DDAN | CF-SB7374N |
| 20 A ≤ AKM < 24 A | CP-508EDBN | CP-508EDBN | CP-508EDBN | CF-SB7374N |
| CDDR < 12 A | CP-507CCAN | N/A | N/A | CF-SB7374N |
| 12 A ≤ CDDR < 20 A | CP-508DCAN | N/A | N/A | CF-SB7374N |
| 20 A ≤ CDDR < 48 A | CM-13A4-010 | N/A | N/A | CF-SB7374N |
| DDR < 12 A | CP-507CCAN | N/A | N/A | CF-SB7374N |
| 12 A ≤ DDR < 20 A | CP-508DCAN | N/A | N/A | CF-SB7374N |

13.3.4 AKD Value Line Cables

Value Line Cables are alternative cable options suitable for most applications. These cables separate power and feedback. Options included in this catalog support Single-turn (GJ) and Multi-turn (GK) for AKD.

| Motor | Power Cable | Power Cable with Brake | SFD | EnDat 2.2, 01 & BiSS |
|--------------------|-------------|------------------------|------------|----------------------|
| AKM < 6 A | VP-507BEAN | VP-508CFAN | VF-DA0474N | VF-SB7374N |
| 6 A ≤ AKM < 12 A | VP-508CEAN | VP-508CFAN | VF-DA0474N | VF-SB7374N |
| 12 A ≤ AKM < 20 A | VP-508DEAN | VP-508DFAN | VF-DA0474N | VF-SB7374N |
| CDDR < 12 A | VP-507BEAN | N/A | N/A | VF-SB7374N |
| 12 A ≤ CDDR < 20 A | VP-508CEAN | N/A | N/A | VF-SB7374N |
| 20 A ≤ CDDR < 48 A | VP-508DEAN | N/A | N/A | VF-SB7374N |
| DDR < 12 A | VP-507BEAN | N/A | N/A | VF-SB7374N |
| 12 A ≤ DDR < 20 A | VP-508CEAN | N/A | N/A | VF-SB7374N |
| 12 A ≤ DDR < 20 A | VP-508DEAN | N/A | N/A | VF-SB7374N |

13.3.5 Digital/analog Inputs/Outputs

13.3.5.1 Digital I/O cable for AKD-N



All AKD-N drives have one 8 poles M12 connector to connect digital control signals.

| Drive | Order Code | Description |
|-------------|--------------|--|
| AKD-N (all) | SAC-8P-M12MS | 5m, M12 mating connector, unconfigured wires |

13.3.5.2 STO cable for AKD-N-DS



AKD-N-DS drives (devices with local STO input) have an additional 4 poles M12 connectors to connect the local STO signals.

| Drive | Order Code | Description |
|---------|--------------|---|
| AKD-N-S | SAC-4P-M12MS | 5m, M12 mating connector, unconfigured wires, A-coded |

13.3.5.3 Fieldbus cable for AKD-N-DF



AKD-N-DF drives (devices with local fieldbus input) have an additional 4 poles M12 connectors to connect the local fieldbus signals.

| Amplifier | Order Code | Description |
|-----------|---------------------|---|
| AKD-N-DF | CCNCN1-025-xxmyy-00 | 5m, M12 mating connector, unconfigured wires, D coded |

13.3.5.4 AKD-N Performance Cables

13.3.5.5 Hybrid Cable Connecting AKD-C Power Supply to AKD-N Axis Module



| Order Code | Description |
|---------------------|--|
| CCNNN1-025-xxmyy-00 | Hybrid cable connecting AKD-C to AKD-N |

Length definition: xx=meters, yy=centimeters

13.3.5.6 Hybrid Cable Connecting AKD-N Axis Module to AKD-N Axis Module



| Order Code | Description |
|-------------------|--|
| SAC-4P-M12MSD/5,0 | Hybrid cable connecting AKD-N to AKD-N |

Length definition: xx=meters, yy=centimeters

13.3.5.7 Hybrid Cable Connecting AKD-N Axis Module to AKM Motor



| Order Code | Description |
|---------------------|---|
| CCJNA3-015-xxmyy-00 | Hybrid cable connecting AKD-N to AKM (SFD GEN3, Single-turn/Multi-turn HiPerFace DSL) |

Length definition: xx=meters, yy=centimeters

13.3.5.8 Performance Cables for AKD-N-DF/DS to AKM Motor



| Motor | Connector | Power Cable | Power Cable with Brake | SFD |
|-----------|-------------------|-------------|------------------------|--------|
| AKM < 6 A | y-tec | CM0NA3 | CM1NA3 | CFSNA3 |
| | Dual Interconnect | CM0NA1 | CM1NA1 | CFSNA1 |

13.3.6 CANopen Bus Cables for AKD



Configured CANopen bus cables are available for AKD. See CANopen Bus Cable Specifications (→ p. 64) for specifications.

| Item | Length | AKD Order Code |
|-------------------|--------|-------------------|
| CANopen bus cable | 0.15 m | P-AKD-CAN-RJ-0-15 |
| CANopen bus cable | 0.5 m | P-AKD-CAN-RJ-0-50 |
| CANopen bus cable | 3.0 m | P-AKD-CAN-RJ-3-00 |

The CANopen bus termination plug is required for bus termination of the last AKD drive connected to the CANopen bus. To connect an AKD drive to a CANopen device with a SubD9 connector, use the CAN RJ12-SubD9.

| Item | AKD Order Code |
|------------------------------|-------------------|
| CANopen bus termination plug | P-AKD-CAN-TERM |
| CAN RJ12-SubD9 adapter | P-AKD-CAN-9d-0-15 |

According to ISO 11898, you should use a bus cable with a characteristic impedance of 120 Ω . The usable cable length depends on the transmission rate. The values that have been measured can be taken as a guide, but they should not be interpreted as limits.

Cable length, depending on the transmission rate:

| | | | |
|-------------------------|------|-----|-----|
| Transmission rate/kbps: | 1000 | 500 | 250 |
| Maximum cable length/m: | 20 | 70 | 115 |

13.4 Motor Power and Feedback Cables

These cables differ in how they are connected to the drive due to the varying requirements for minimum code distances, different shielding concepts, depending on rated voltage, and current load. The following pre-assembled, ready-to-use cables meet the requirements of relevant CE and UL standards. See Motor Power Cable Specifications (→ p. 66) and Motor Feedback Cable Specifications (→ p. 72) for engineering details on all cables.



Value Line Cables



Flex Line Cables



S700 Cables

13.4.0.1 Power Cables

| Cable Rating* | Value Line | OD ¹ (mm) | Value Line w/ Brake | OD ¹ (mm) | Flex Line | OD ¹ (mm) | Flex Line w/ Brake | OD ¹ (mm) |
|---------------|---------------|----------------------|---------------------|----------------------|-----------------|----------------------|--------------------|----------------------|
| 3/6 A | VP-507BEAN-XX | 9.4 | VP-508CFAN-XX | 10.9 | CP-507CCAN-XX-X | 12.7 | CP-507CDAN-XX-X | 14.5 |
| 12 A | VP-507BEAN-XX | 10.3 | VP-508CFAN-XX | 10.9 | CP-507CCAN-XX-X | 12.7 | CP-507CDAN-XX-X | 14.5 |
| 20 A | VP-508DEAN-XX | 11.7 | VP-508DFAN-XX | 12.9 | CP-508DCAN-XX-X | 14.5 | CP-508DDAN-XX-X | 16.6 |
| 24A | Not Available | N/A | Not Available | N/A | CP-508EBDN-XX-X | 18.3 | CP-508EBDN-XX-X | 18.3 |

*Continuous current

¹Outside diameter

13.4.0.2 Feedback Cables

| Feedback Type | Value Line | OD (mm) | Flex Line | OD (mm) |
|----------------------|---------------|---------|-----------------|---------|
| SFD | VF-DA474N-XX | 6.7 | CF-DA0374N-XX-X | 7.5 |
| EnDat 2.1/BiSS | VF-SB4474N-XX | 9.7 | CF-SB7374N-XX-X | 11.2 |
| Resolver | VF-RA2474N-XX | 9.7 | CF-RA2574N-XX-X | 9.5 |
| Incremental/comcoder | Not available | N/A | CF-CB7374N-XX-X | 11.2 |

13.4.1 Order Codes for S700 Motor Power Cables

13.4.1.1 S724 Order Codes

With shield plate at amplifier's end, motor connector size 1.5

| Description | Order Code |
|-----------------------------|------------|
| Motor cable 5m (4x6) | DE-201579 |
| Motor cable 10m (4x6) | DE-201580 |
| Motor cable 15m (4x6) | DE-201581 |
| Motor cable 20m (4x6) | DE-201582 |
| Motor cable 25m (4x6) | DE-201583 |
| Motor cable 5m (4x6+(2x1)) | DE-201584 |
| Motor cable 10m (4x6+(2x1)) | DE-201585 |
| Motor cable 15m (4x6+(2x1)) | DE-201586 |
| Motor cable 20m (4x6+(2x1)) | DE-201587 |
| Motor cable 25m (4x6+(2x1)) | DE-201588 |

13.4.1.2 S748 Order Codes

With shield plate at amplifier's end, motor connector size 1.5

| Description | Order Code |
|------------------------------|------------|
| Motor cable 5m (4x10) | DE-201589 |
| Motor cable 10m (4x10) | DE-201590 |
| Motor cable 15m (4x10) | DE-201591 |
| Motor cable 20m (4x10) | DE-201592 |
| Motor cable 25m (4x10) | DE-201593 |
| Motor cable 5m (4x10+(2x1)) | DE-201594 |
| Motor cable 10m (4x10+(2x1)) | DE-201595 |
| Motor cable 15m (4x10+(2x1)) | DE-201596 |
| Motor cable 20m (4x10+(2x1)) | DE-201597 |
| Motor cable 25m (4x10+(2x1)) | DE-201598 |

13.5 Preparing Motor Cables (Motor End)

13.5.1 Motor Series AKM2...8, 6SMx7, DBL2...6, DBK

Please note that different conductor cross-sections are required for different motors, and for motors with a holding brake, the brake signals are also attached through this connector.

Connections: The view is as seen from the contact side of the connector:

| Standard (size 1), wire max 4mm ² | | | | |
|--|------------|---------------|------------|---------------|
| | Pin | Signal | Pin | Signal |
| | 1 | U2 | A | + Br |
| | 4 | V2 | B | - Br |
| | 3 | W2 | C | n.c. |
| | (2) | PE | D | n.c. |

| Option H (size 1.5), wire max. 10mm ² | | | | |
|--|------------|---------------|------------|---------------|
| | Pin | Signal | Pin | Signal |
| | U | U2 | + | + Br |
| | V | V2 | - | - Br |
| | W | W2 | 1 | n.c. |
| | | PE | 2 | n.c. |

13.6 Preparing Cables for Drive (S701 to S724)

The motor is connected to the S701...724 by a Power Combicon connector. You can obtain the connector kit from Kollmorgen™ (connector, housing, shield plate, rubber bushes, installation material) with the order code DE-200453. Please take note that the connector can accept a maximum conductor cross-section of 6mm².

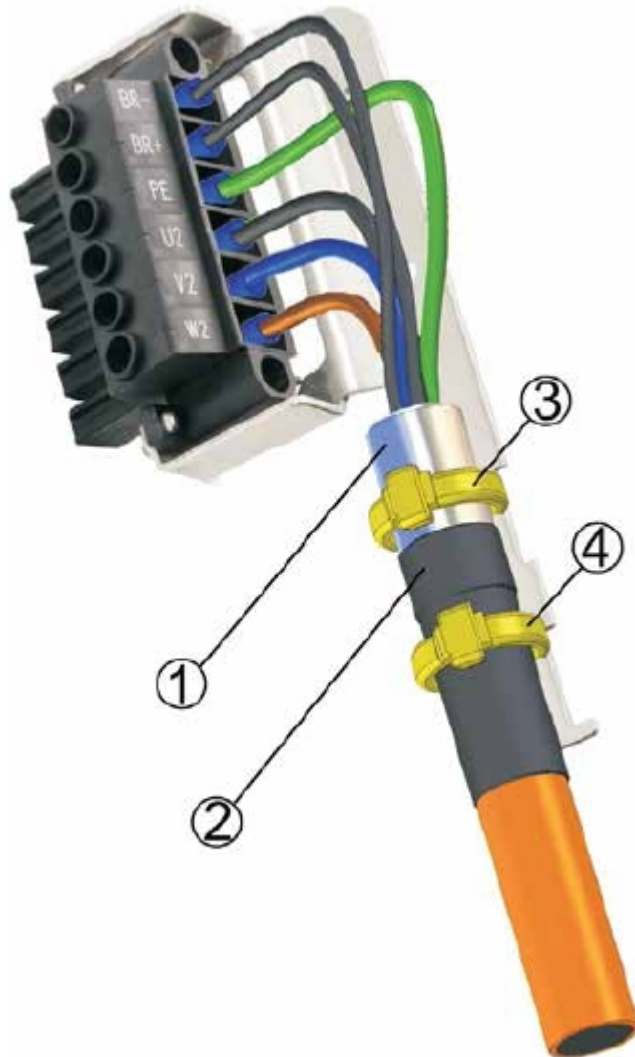

Strip the external cable sheath to a length of approx. 120 mm, **taking care not to damage the braided shield**. Push the braided shield (1) back over the cable and secure with a rubber sleeve (2) or shrink sleeve.

Shorten all the wires apart from the protective earth (PE) wire (green/yellow) by about 20 mm so that the PE wire is now the longest wire. Strip all wires and fit wire end ferrules.

Secure the braided shield of the cable to the shroud with a cable tie or a hose clamp (3) and use a second tie (4) to fasten the cable over the rubber sleeve. Wire the connector as shown in the connection diagram. Plug in the connector to the socket on the front of the S701...724.

Screw the connector in place. This ensures that there is conductive contact over a large surface area between the braided shield and the front panel.

13.7 CANopen Bus Cable Specifications

All cables supplied with AKD and S700 drives are RoHS compliant.

13.7.1 CANopen Cable P-AKD-CAN-RJ-z-zz

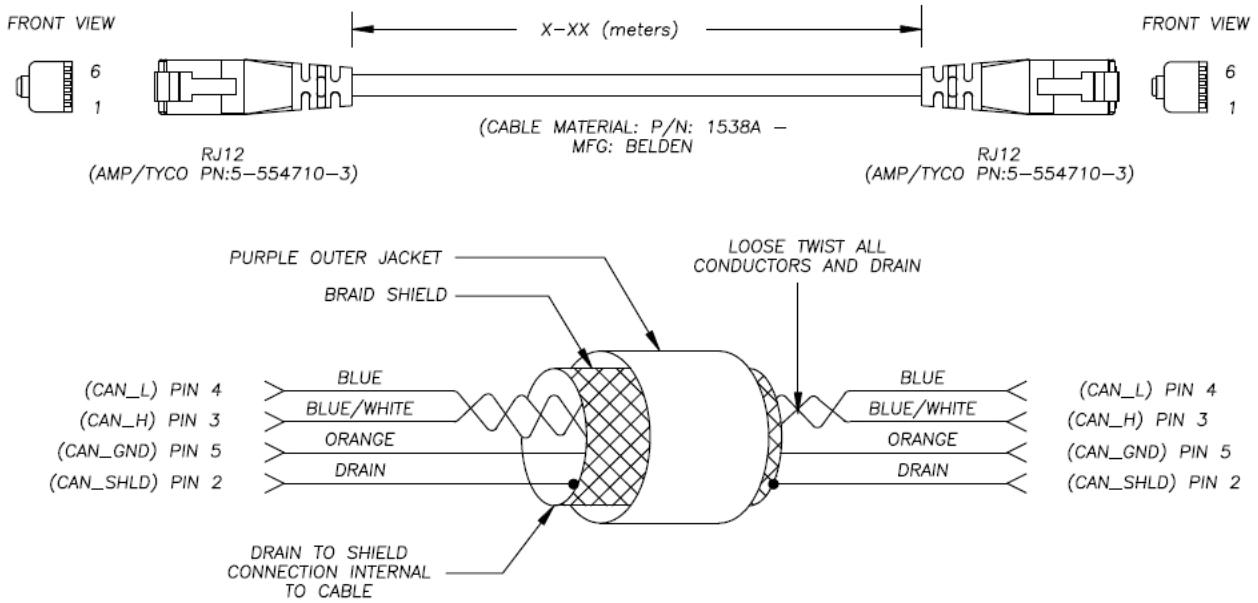

| Cable Specifications | |
|----------------------|-----------------|
| Outside diameter | 6.7 mm ± 0.2 mm |
| RoHS Compliant | Yes |
| Length: | |
| PAKD-CANRJ-0-15 | 0.15 m |
| PAKD-CANRJ-0-30 | 0.3 m |
| PAKD-CANRJ-1-00 | 1 m |
| PAKD-CANRJ-3-00 | 3 m |

13.7.2 CANopen Cable P-AKD-CAN-TERM

FRONT VIEW

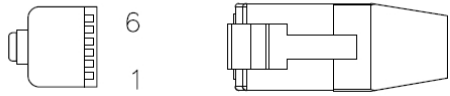

RJ12
(AMP/TYCO PN:5-554710-3)

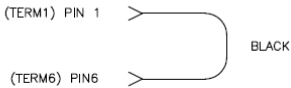

13.7.3 CANopen Cable PAKD-CAN-9D-0-15

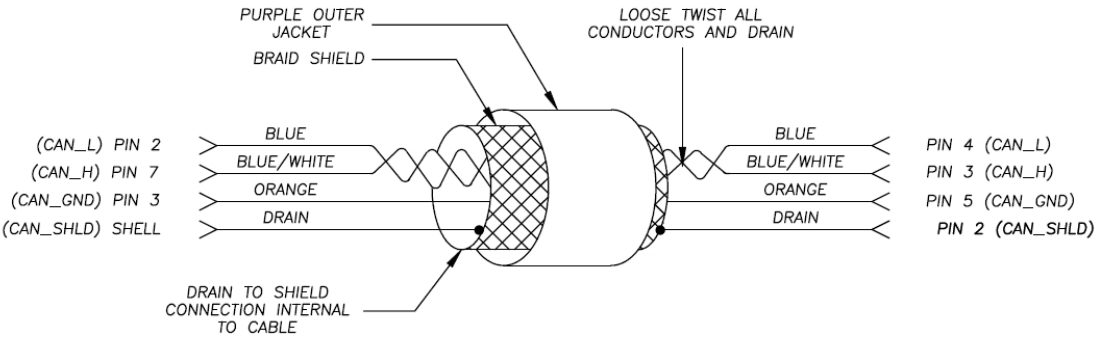
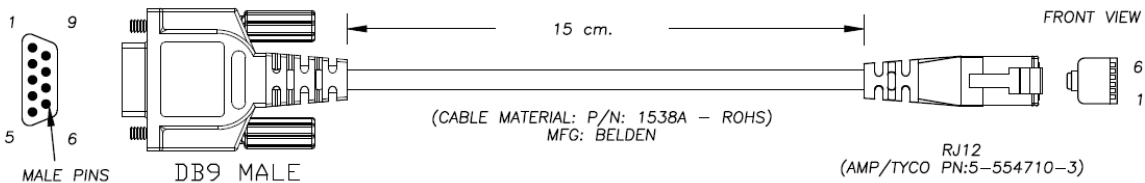

13.7.4 Motor Power Cable Specifications

All cables supplied with AKD and S700 drives are RoHS compliant.

13.7.4.1 Cable Routing Standards

UL 508C and UL 508A indicate that wires, when routed together, shall be rated for the highest voltage involved in all of the circuits. This means that value line feedback cables which are 300V rated are not appropriate when routed directly next to motor power cables that carry more voltage than 300V. They should be physically separated. Performance line cables are recommended when this is a concern.

The NFPA 70 (NEC) article 300.3(C)(1) says that for circuits that are 600V or less, conductors of ac and dc circuits shall be permitted to occupy the same equipment wiring enclosure, cable, or raceway. All conductors shall have an insulation rating equal to at least the maximum circuit voltage applied to any conductor within the enclosure, cable, or raceway.

13.7.4.2 AKD 1.5 – 6 A Power Cable, VP-507BEAN-xx

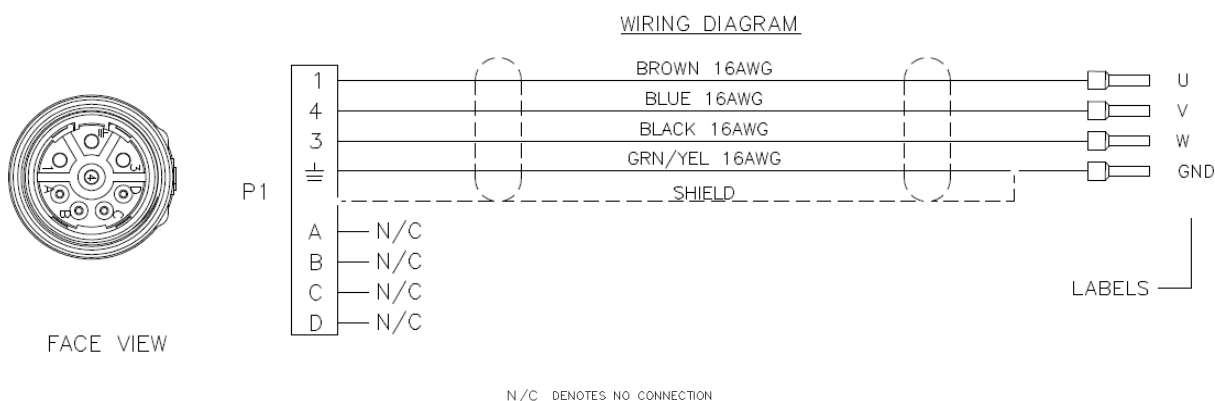

| Cable Specifications | |
|-----------------------|--|
| Cable jacket material | TPE |
| Outside diameter | 9.4 mm ± 0.25 mm |
| Bend radius | 94 mm |
| Static flex rating | Not rated |
| Dynamic flex rating | Not rated |
| Temperature rating | 105 C |
| Voltage rating | 600 V (see Cable Routing Standards) |
| RoHS Compliant | Yes |
| Assembly Weight: | |
| VP-507BEAN-01 | 0.258 kg |
| VP-507BEAN-03 | 0.536 kg |
| VP-507BEAN-06 | 0.955 kg |
| VP-507BEAN-09 | 1.372 kg |
| VP-507BEAN-12 | 1.789 kg |

13.7.4.3 AKD 12 A Power Cable, VP-508CEAN-zz

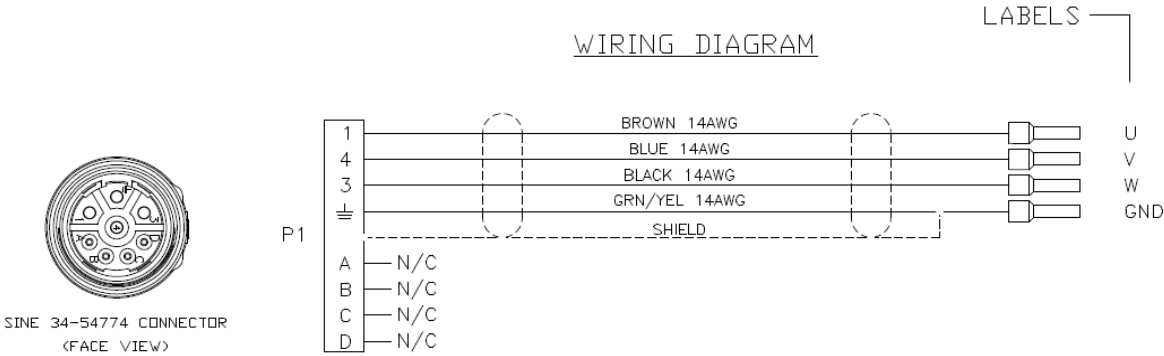

N/C DENOTES NO CONNECTION

| Cable Specifications | |
|-----------------------|--|
| Cable jacket material | TPE |
| Outside diameter | 10.25 mm ± 0.30 mm |
| Bend radius | 102.5 mm |
| Static flex rating | Not rated |
| Dynamic flex rating | Not rated |
| Temperature rating | 105 C |
| Voltage rating | 600 V (see Cable Routing Standards) |
| RoHS Compliant | Yes |
| Assembly Weight: | |
| VP-508CEAN-01 | 0.247 kg |
| VP-508CEAN-03 | 0.521 kg |
| VP-508CEAN-06 | 0.942 kg |
| VP-508CEAN-09 | 1.363 kg |
| VP-508CEAN-12 | 1.784 kg |

13.7.4.4 AKD 12 A Power Cable with Brake, VP-508CFAN-zz

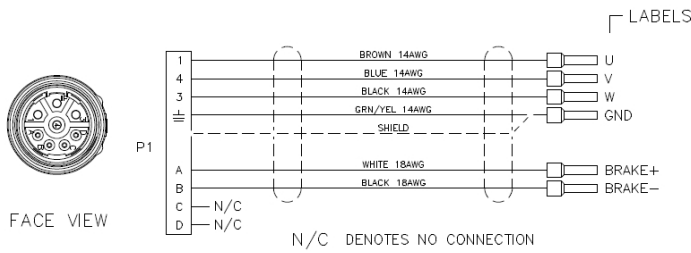
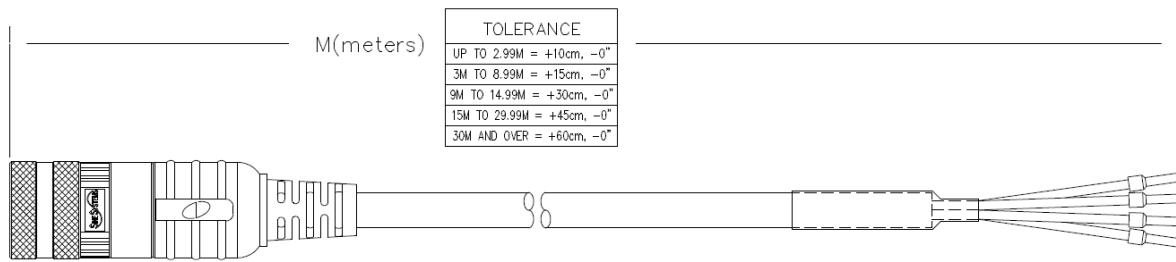

| Cable Specifications | |
|-----------------------|--|
| Cable jacket material | TPE |
| Outside diameter | 10.90 mm ± 0.30 mm |
| Bend radius | 109 mm |
| Static flex rating | Not rated |
| Dynamic flex rating | Not rated |
| Temperature rating | 105 C |
| Voltage rating | 600 V (see Cable Routing Standards) |
| RoHS Compliant | Yes |
| AWM Style | UL20328 |
| Assembly Weight: | |
| VP-508CFAN-01-0 | 0.256 kg |
| VP-508CFAN-03-0 | 0.767 kg |
| VP-508CFAN-06-0 | 1.534 kg |
| VP-508CFAN-09-0 | 2.301 kg |
| VP-508CFAN-12-0 | 3.068 kg |

13.7.4.5 AKD 24 A Power Cable with Brake, VP-508DEAN-zz

WIRING DIAGRAM

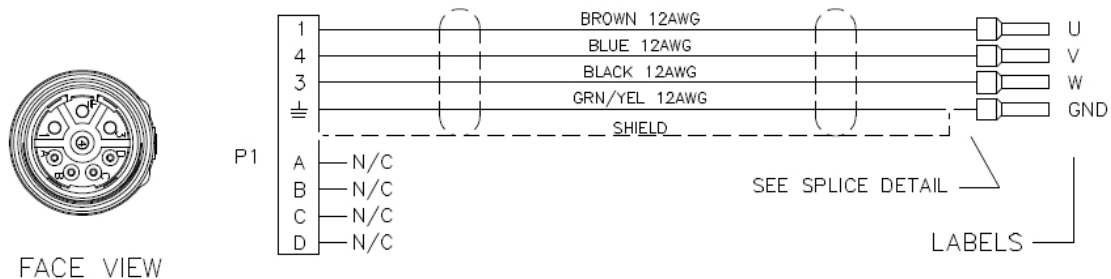

N/C DENOTES NO CONNECTION

| Cable Specifications | |
|-----------------------|--|
| Cable jacket material | TPE |
| Outside diameter | 11.70 mm ± 0.30 mm |
| Bend radius | 117 mm |
| Static flex rating | Not rated |
| Dynamic flex rating | Not rated |
| Temperature rating | 105 C |
| Voltage rating | 600 V (see Cable Routing Standards) |
| RoHS Compliant | Yes |
| Assembly Weight: | |
| VP-508DEAN-01-0 | 0.292 kg |
| VP-508DEAN-03-0 | 0.874 kg |
| VP-508DEAN-06-0 | 1.750 kg |
| VP-508DEAN-09-0 | 2.622 kg |
| VP-508DEAN-12-0 | 3.496 kg |

13.7.4.6 AKD 24 A Power Cable with Brake, VP-508DFAN-zz

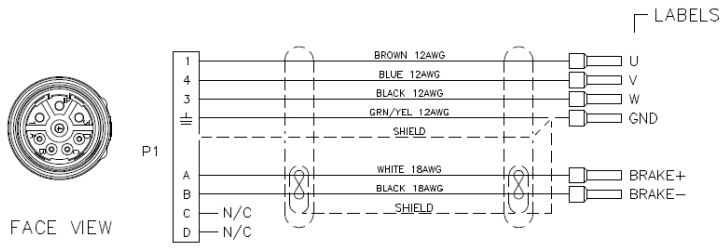
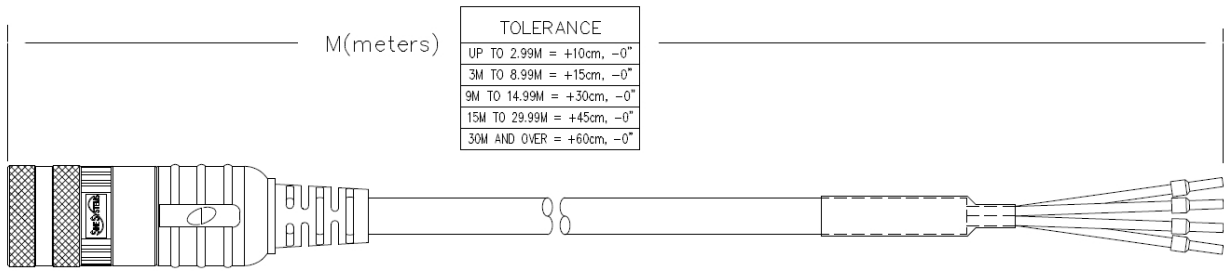

N/C DENOTES NO CONNECTION

| Cable Specifications | |
|-----------------------|--|
| Cable jacket material | TPE |
| Outside diameter | 12.90 mm ± 0.20 mm |
| Bend radius | 129 mm |
| Static flex rating | Not rated |
| Dynamic flex rating | Not rated |
| Temperature rating | 105 C |
| Voltage rating | 600 V (see Cable Routing Standards) |
| RoHS Compliant | Yes |
| AWM Style | UL20328 |
| Assembly Weight: | |
| VP-508DFAN-01-0 | 0.328 kg |
| VP-508DFAN-03-0 | 0.983 kg |
| VP-508DFAN-06-0 | 1.966 kg |
| VP-508DFAN-09-0 | 2.949 kg |
| VP-508DFAN-12-0 | 3.932 kg |

13.7.5 CANopen Cable PAKD-CAN-FL-3-00

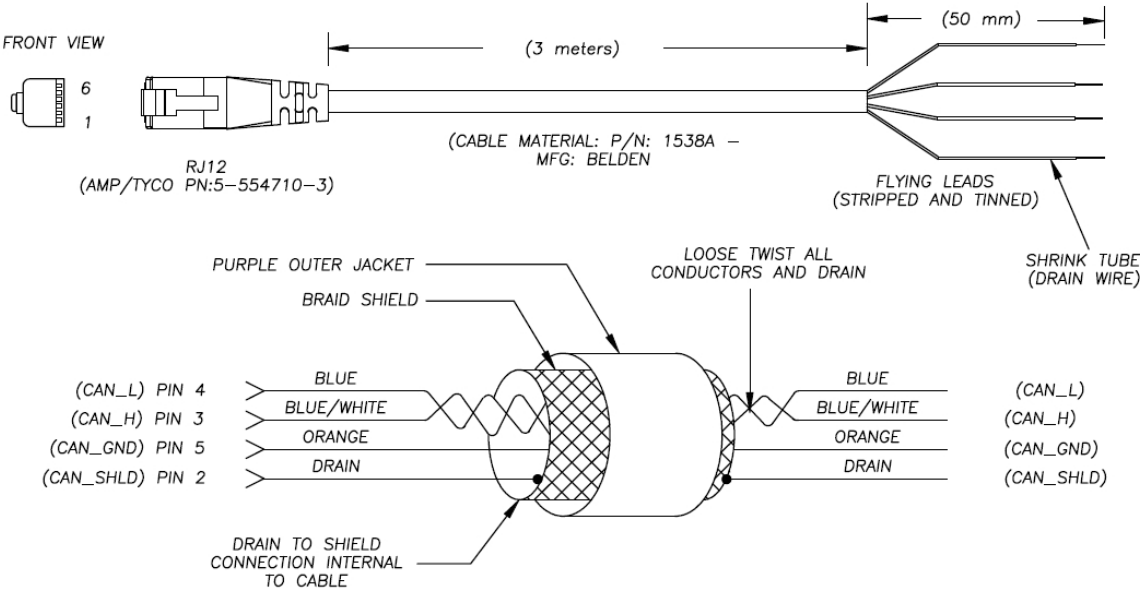

13.8 Motor Feedback Cable Specifications

All cables supplied with AKD and S700 drives are RoHS compliant.

13.8.1 Cable Routing Standards

UL 508C and UL 508A indicate that wires, when routed together, shall be rated for the highest voltage involved in all of the circuits. This means that value line feedback cables which are 300V rated are not appropriate when routed directly next to motor power cables that carry more voltage than 300V. They should be physically separated. Performance line cables are recommended when this is a concern.

The NFPA 70 (NEC) article 300.3(C)(1) says that for circuits that are 600V or less, conductors of ac and dc circuits shall be permitted to occupy the same equipment wiring enclosure, cable, or raceway. All conductors shall have an insulation rating equal to at least the maximum circuit voltage applied to any conductor within the enclosure, cable, or raceway.

13.8.2 Motor Feedback Cable, VF-DA0-474N-zz

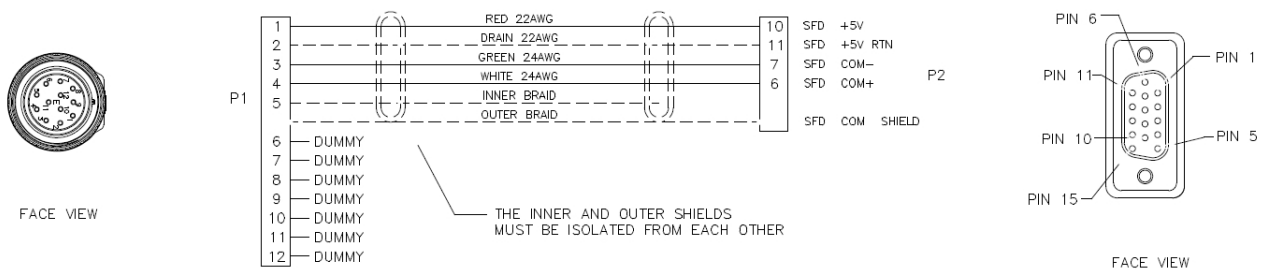

N/C DENOTES NO CONNECTION

| Cable Specifications | |
|-----------------------|--|
| Cable jacket material | TPE |
| Outside diameter | 6.7 mm ± 0.2 mm |
| Bend radius | 67 mm |
| Static flex rating | Not rated |
| Dynamic flex rating | Not rated |
| Temperature rating | 105 C |
| Voltage rating | 300 V (see Cable Routing Standards) |
| RoHS Compliant | Yes |
| Assembly Weight: | |
| VF-DA0-474N-01 | 0.211 kg |
| VF-DA0-474N-03 | 0.357 kg |
| VF-DA0-474N-06 | 0.568 kg |
| VF-DA0-474N-09 | 0.779 kg |
| VF-DA0-474N-12 | 0.99 kg |

13.8.3 Feedback Resolver Cable, VF-RA2474N-zz

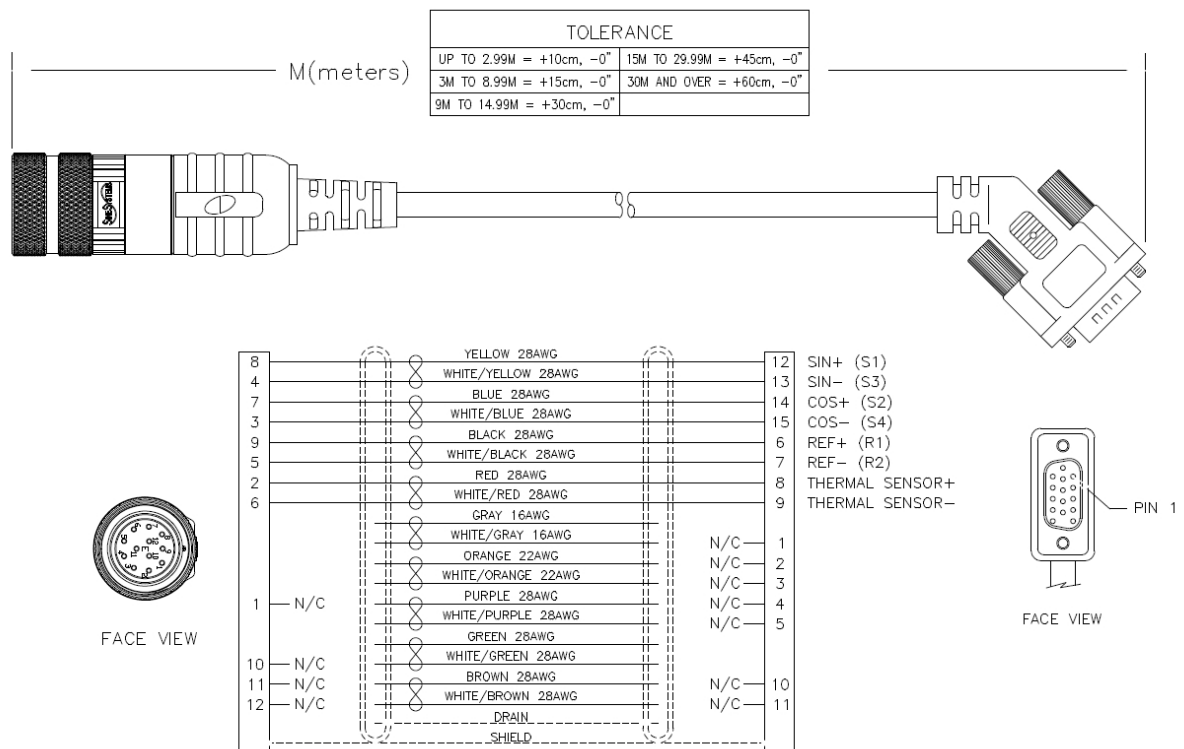

∞ = TWISTED PAIR

N/C DENOTES NO CONNECTION

CONNECTOR BACKSHELL SHIELDED 360° (BOTH ENDS)

| Cable Specifications | |
|-----------------------|--|
| Cable jacket material | TPE |
| Outside diameter | 9.65 mm ± 0.35 mm |
| Bend radius | 96.5 mm |
| Static flex rating | Not rated |
| Dynamic flex rating | Not rated |
| Temperature rating | 105 C |
| Voltage rating | 300 V (see Cable Routing Standards) |
| AWM Style | UL20327 |
| RoHS Compliant | Yes |
| Assembly Weight: | |
| VF-RA2474N-01-0 | 0.273 kg |
| VF-RA2474N-03-0 | 0.551 kg |
| VF-RA2474N-06-0 | 0.968 kg |
| VF-RA2474N-09-0 | 1.385 kg |
| VF-RA2474N-12-0 | 1.793 kg |

13.8.4 Sine Encoder Feedback Cable, VF-SB4474N-zz

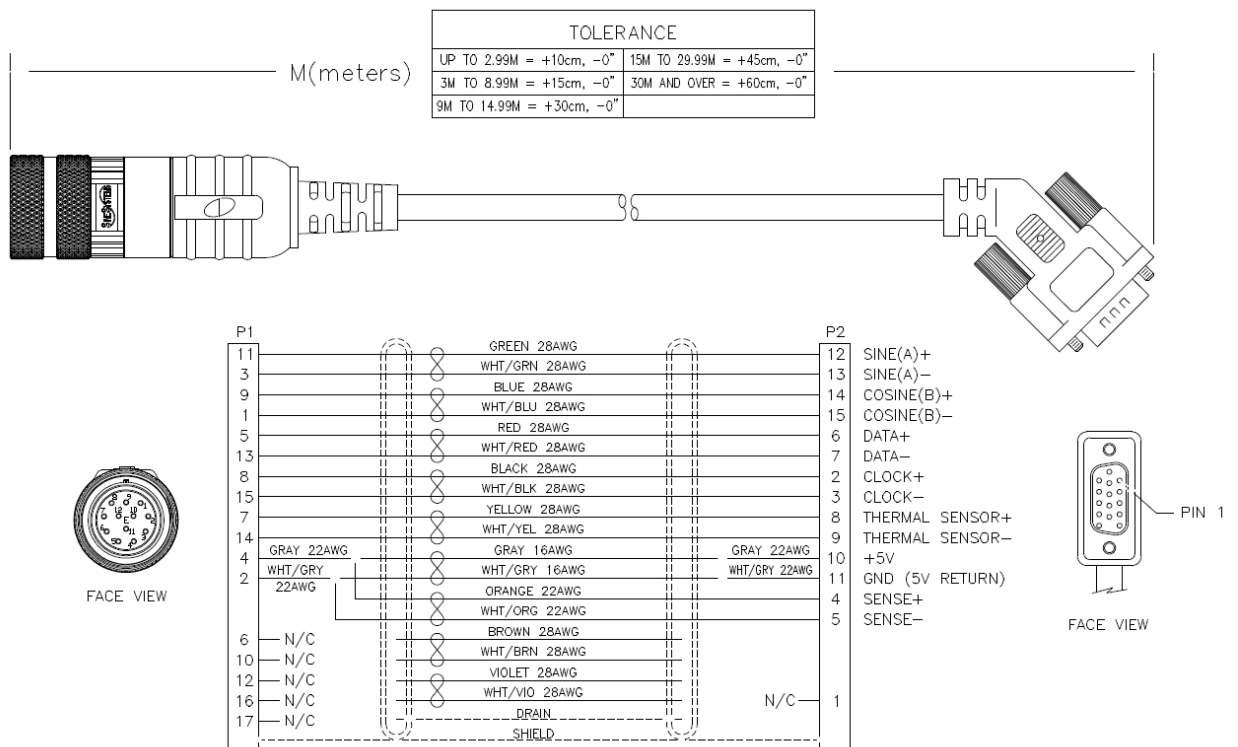

∞ = TWISTED PAIR

N/C DENOTES NO CONNECTION

CONNECTOR BACKSHELL SHIELDED 360° (BOTH ENDS)

| Cable Specifications | |
|-----------------------|--|
| Cable jacket material | TPE |
| Outside diameter | 9.65 mm ± 0.35 mm |
| Bend radius | 96.5 mm |
| Static flex rating | Not rated |
| Dynamic flex rating | Not rated |
| Temperature rating | 105 C |
| Voltage rating | 300 V (see Cable Routing Standards) |
| AWM Style | UL20327 |
| RoHS Compliant | Yes |
| Assembly Weight: | |
| VF-SB4474N-01-0 | 0.269 kg |
| VF-SB4474N-03-0 | 0.547 kg |
| VF-SB4474N-06-0 | 0.974 kg |
| VF-SB4474N-09-0 | 1.386 kg |
| VF-SB4474N-12-0 | 1.798 kg |

13.8.5 Resolver Cables for S700/AKD



All the motors in our range feature the same 12-pin connector for the resolver connection. This connector is also used for the connections from the motor's thermal protection contact to the servo amplifier. The servo amplifiers have a Sub-D female connector for the connection of a resolver and the thermal protection contact. The cable shield is connected to the servo amplifier via the connector housing.

13.8.5.1 Resolver Cable Order Codes

| Description | S700 | | AKD | |
|-----------------------------|--------|------------|--------|-------------------|
| | Length | Order Code | Length | Order Code |
| Resolver Cable (4x(2x0.25)) | 5m | DE-84972 | 1m | CFR0A1-002-001-00 |
| Resolver Cable (4x(2x0.25)) | 10m | DE-84973 | 3m | CFR0A1-002-003-00 |
| Resolver Cable (4x(2x0.25)) | 50m | DE-84974 | 6m | CFR0A1-002-006-00 |
| Resolver Cable (4x(2x0.25)) | 20m | DE-84975 | 12m | CFR0A1-002-012-00 |
| Resolver Cable (4x(2x0.25)) | 30m | DE-87655 | 24m | CFR0A1-002-024-00 |

13.8.5.2 Preparing Resolver Cables

For cable lengths up to 100m use a shielded and sheathed cable, with cores as twisted pairs (suggestion acc. to DIN 47100). Please consult our customer support for cables longer than 100m.

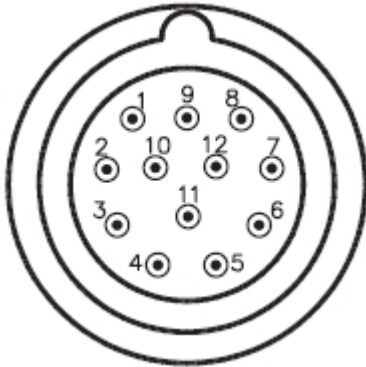

View: solder side of the motor connector.

| S700 Pin | AKD X10 High Density Pin | Pair No. | Core Color acc. to IEC 60757 | Motor End Pin | Function 6SM, DBL/DBK, AKM |
|----------|--------------------------|----------|------------------------------|---------------|----------------------------|
| - | | - | - | 1 | n.c. |
| 2 | 8 | 4 | BU | 2 | Thermal Protection |
| 3 | 15 | 2 | YE | 3 | S4 Cosine+ |
| 4 | 13 | 3 | PK | 4 | S3 Sine- |
| 5 | 7 | 1 | BN | 5 | R2 Reference+ |
| 6 | 9 | 4 | RD | 6 | Thermal Protection |
| 7 | 14 | 2 | GN | 7 | S2 Cosine- |
| 8 | 12 | 3 | GY | 8 | S1 Sine+ |
| 9 | 6 | 1 | WH | 9 | R1 Reference- |

13.8.6 Encoder Cables for S700/AKD



All the motors in our range feature the same 17-pin connector for the encoder connection (EnDat, HIPERFACE, BiSS etc.). This connector is also used for the connections from the motor's thermal protection contact to the servo amplifier. The servo amplifiers have a Sub-D female connector for the connection of the encoder and the thermal protection contact. The cable shield is connected to the servo amplifier via the connector housing.

13.8.6.1 Encoder Cable Order Codes

| Description | S700 | | AKD | |
|----------------------------|--------|------------|--------|-------------------|
| | Length | Order Code | Length | Order Code |
| Encoder Cable (7x(2x0.25)) | 5m | DE-90287 | 1m | CFE0A1-002-001-00 |
| Encoder Cable (7x(2x0.25)) | 10m | DE-91019 | 3m | CFE0A1-002-003-00 |
| Encoder Cable (7x(2x0.25)) | 15m | DE-91811 | 6m | CFE0A1-002-006-00 |
| Encoder Cable (7x(2x0.25)) | 20m | DE-91807 | 12m | CFE0A1-002-012-00 |
| Encoder Cable (7x(2x0.25)) | 30m | DE-92205 | 24m | CFE0A1-002-024-00 |

13.8.6.2 Preparing Encoder Cables

Up to a cable length of 50m, use a shielded and sheathed cable with cores in twisted pairs (suggestion acc. to DIN 47100). Please consult our customer support for cables longer than 50m.

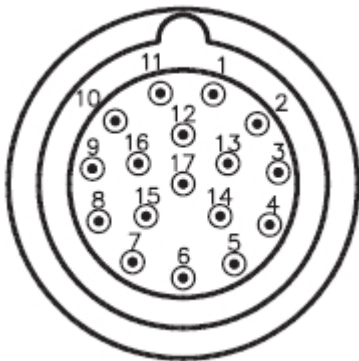

View: solder side of the motor connector.

| Pin: Amplifier End | | | Pair | Core Color acc. to IEC 60757 | Pin: Motor End |
|--------------------|------------|-----------|------|------------------------------|----------------------------|
| S700 | AKD | | | | Encoder ECN/EQN/SRS/SRM |
| | EnDat BiSS | Hiperface | | | |
| 1 | 15 | 12 | 1 | WH | 1 |
| 2 | 11 | 11 | 6 | RD/BU | 2 |
| 3 | 13 | 14 | 2 | GN | 3 |
| 4 | 10 | 10 | 6 | GY/PK | 4 |
| 5 | 6 | 6 | 3 | GY | 5 |
| 6 | - | - | - | - | - |
| 7 | 9 | 9 | 7 | BN/GN | 7 |
| 8 | 2 | - | 4 | BU | 8 |
| 9 | 14 | 13 | 1 | BN | 9 |
| 10 | 5 | 5-4 | 5 | VT | 10 |
| 11 | 12 | 15 | 2 | YE | 11 |
| 12 | 4 | 4-5 | 5 | BK | 12 |
| 13 | 7 | 7 | 3 | PK | 13 |
| 14 | 8 | 8 | 7 | WH/GN | 14 |
| 15 | 3 | - | 4 | RD | 15 |

13.8.7 ComCoder Cables for S700/AKD



All the motors in our range feature the same 17-pin connector for the ComCoder connection. This connector is also used for the connections from the motor's thermal protection contact to the servo amplifier. The servo amplifiers have a Sub-D female connector for the connection of the ComCoder and the thermal protection contact. The cable shield is connected to the servo amplifier via the connector housing.

13.8.7.1 ComCoder Cable Order Codes

| Description | S700 | | AKD | |
|-----------------------------|--------|------------|--------|-------------------|
| | Length | Order Code | Length | Order Code |
| ComCoder Cable (8x(2x0.25)) | 5m | DE-107915 | 1m | CFC0A1-002-001-00 |
| ComCoder Cable (8x(2x0.25)) | 10m | DE-107916 | 3m | CFC0A1-002-003-00 |
| ComCoder Cable (8x(2x0.25)) | 15m | DE-107917 | 6m | CFC0A1-002-006-00 |
| ComCoder Cable (8x(2x0.25)) | 20m | DE-107918 | 12m | CFC0A1-002-012-00 |
| ComCoder Cable (8x(2x0.25)) | 30m | DE-107919 | 24m | CFC0A1-002-024-00 |

13.8.7.2 Preparing ComCoder Cable

Up to a cable length of 25m, use a shielded and sheathed cable with cores in twisted pairs (suggestion acc. to DIN 47100). Please consult our customer support for cables longer than 25m.

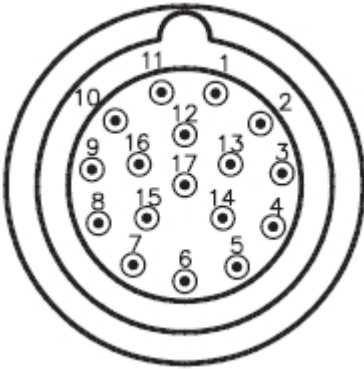

View: Solder side of the motor connector.

| Pin Amplifier End S700 | Pin AKD X10 High Density | Pair | Core color to IEC 60757 | Pin: Motor End |
|------------------------|--------------------------|------|-------------------------|----------------|
| 1 | 14 | 1 | WH | 1 |
| 2 | 11 | 6 | RD/BU | 7 |
| 3 | 12 | 2 | GN | 3 |
| 4 | 10 | 6 | GY/PK | 10 |
| 5 | 6 | 3 | GY | 5 |
| 6 | 1 | 4 | RD | 15 |
| 7 | 9 | 7 | BN/GN | 8 |
| 8 | 2 | 4 | BU | 16 |
| 9 | 15 | 1 | BN | 2 |
| 10 | 5 | 5 | VT | 7 |
| 11 | 13 | 2 | YE | 4 |
| 12 | 4 | 5 | BK | 10 |
| 13 | 7 | 3 | PK | 6 |
| 14 | 8 | 7 | WH/GN | 9 |
| 15 | 3 | 8 | WH/YE | 17 |

About KOLLMORGEN

Kollmorgen™ is a leading provider of motion systems and components for machine builders. Through world-class knowledge in motion, industry-leading quality and deep expertise in linking and integrating standard and custom products, Kollmorgen™ delivers breakthrough solutions that are unmatched in performance, reliability and ease-of-use, giving machine builders an irrefutable marketplace advantage.



Join the [Kollmorgen™ Developer Network](#) for product support. Ask the community questions, search the knowledge base for answers, get downloads, and suggest improvements.

North America KOLLMORGEN

201 West Rock Road
Radford, VA 24141, USA

Web: www.kollmorgen.com
Mail: support@kollmorgen.com
Tel.: +1 - 540 - 633 - 3545
Fax: +1 - 540 - 639 - 4162

Europe KOLLMORGEN Europe GmbH

Pempelfurtstr. 1
40880 Ratingen, Germany

Web: www.kollmorgen.com
Mail: technik@kollmorgen.com
Tel.: +49 - 2102 - 9394 - 0
Fax: +49 - 2102 - 9394 - 3155

South America KOLLMORGEN

Avenida João Paulo Ablas, 2970
Jardim da Glória, Cotia – SP
CEP 06711-250, Brazil

Web: www.kollmorgen.com
Mail: contato@kollmorgen.com
Tel.: +55 11 4615-6300
Fax: +1 - 540 - 639 - 4162

China and SEA KOLLMORGEN

Room 302, Building 5, Lihpao Plaza,
88 Shenbin Road, Minhang District,
Shanghai, China.

Web: www.kollmorgen.cn
Mail: sales.china@kollmorgen.com
Tel.: +86 - 400 668 2802
Fax: +86 - 21 6248 5367

KOLLMORGEN®

Because Motion Matters™