

**MMC™**

# **Hardware Manual**

Version 14.0

Belden® is a registered trademark of Cooper Industries, Inc.

IBM is a registered trademark of International Business Machines Corp.

Windows 95, 98, NT, Microsoft, and MS-DOS are registered trademarks of Microsoft Corporation.

MOD HUB is a trademark of Contemporary Control Systems, Inc.

ARCNET® is a registered trademark of Datapoint Corporation.

ST is a trademark of AT&T Bell Labs.

Temposonics™ is a trademark of Contemporary Control Systems, Inc.

DeviceNet™ is a trademark of Open DeviceNet™ Vendor Association. Inc.

Pentium and PentiumPro are trademarks of Intel Corporation.

PiC900, PiCPro, MMC, PiCServoPro, PiCTune, PiCProfile, LDO Merge, PiCMicroTerm and PiC Programming Pendant are trademarks of G & L Motion Control Inc.

## **NOTE**

Progress is an on-going commitment at G & L Motion Control Inc.. We continually strive to offer the most advanced products in the industry; therefore, information in this document is subject to change without notice. The illustrations and specifications are not binding in detail. G & L Motion Control Inc., shall not be liable for any technical or editorial omissions occurring in this document, nor for any consequential or incidental damages resulting from the use of this document.

DO NOT ATTEMPT to use any G & L Motion Control Inc. product until the use of such product is completely understood. It is the responsibility of the user to make certain proper operation practices are understood. G & L Motion Control Inc. products should be used only by qualified personnel and for the express purpose for which said products were designed.

Should information not covered in this document be required, contact the Customer Service Department, G & L Motion Control Inc., 672 South Military Road, P.O. Box 1960, Fond du Lac, WI 54936-1960. G & L Motion Control Inc. can be reached by telephone at (920) 921-7100 or (800) 558-4808 in the United States or by e-mail at [glmotion.support@danahermotion.com](mailto:glmotion.support@danahermotion.com)

Release 1905

Catalog No. (Order No.) M.1300.7620, Version Part Number M.1301.5520 Rev 1

© 1999-2005 G & L Motion Control Inc.

Belden® is a registered trademark of Cooper Industries, Inc.

IBM is a registered trademark of International Business Machines Corp.

Windows 95, 98, NT, Microsoft, and MS-DOS are registered trademarks of Microsoft Corporation.

MOD HUB is a trademark of Contemporary Control Systems, Inc.

ARCNET® is a registered trademark of Datapoint Corporation.

ST is a trademark of AT&T Bell Labs.

Temposonics™ is a trademark of Contemporary Control Systems, Inc.

DeviceNet™ is a trademark of Open DeviceNet™ Vendor Association. Inc.

Pentium and PentiumPro are trademarks of Intel Corporation.

PiC900, PiCPro, MMC, PiCServoPro, PiCTune, PiCProfile, LDO Merge, PiCMicroTerm and PiC Programming Pendant are trademarks of G & L Motion Control Inc.

# Table of Contents: MMC Hardware Manual

## Table of Contents: MMC Hardware Manual 1.TOC-1

<b>1</b>	<b>Safety Precautions .....</b>	<b>1</b>
1.1	System Safety .....	1
1.1.1	User Responsibility .....	1
1.1.2	Safety Instructions.....	1
1.2	Safety Signs .....	2
1.3	Warning Labels .....	3
1.4	Safety First .....	4
1.5	Safety Inspection .....	4
1.5.1	Before Starting Operations.....	4
1.6	After Shutdown .....	4
1.7	Operating Safely .....	4
1.8	Electrical Service & Maintenance Safety .....	5
1.9	Safe Cleaning Practices .....	6
<b>2</b>	<b>Introduction .....</b>	<b>7</b>
2.1	Overview .....	7
2.2	Major Components .....	7
2.2.1	Machine Control Board.....	9
2.2.2	Motion Control Board .....	9
2.2.2.1	Analog Servo board .....	9
2.2.2.2	SERCOS board .....	10
2.2.3	Option Modules.....	11
<b>3</b>	<b>Mounting the MMC Control .....</b>	<b>13</b>
<b>4</b>	<b>Adding an Option Module to the MMC Control .....</b>	<b>15</b>
<b>5</b>	<b>Dimensions and Mounting of MMC with Option Module Attached 17</b>	
<b>6</b>	<b>System Power and Environment Requirements .....</b>	<b>19</b>
6.1	General Power and Environment Requirements .....	19
6.2	Control Cabinet Specifications .....	19
6.3	Power Distribution Diagram .....	20
6.4	Notes for 24V Power Supply and MMC .....	21
6.5	Grounding the System .....	24
6.6	Controlling Heat Within the System .....	25
6.7	Handling an MMC .....	26
<b>7</b>	<b>System Wiring Guidelines .....</b>	<b>27</b>
7.1	Recommended Signal Separation .....	27
7.2	Differential Devices for Analog and Encoder Signals .....	29
<b>8</b>	<b>Starting an Operation .....</b>	<b>31</b>
8.1	Connecting the MMC to the Application .....	31
8.2	Basic Setup and Maintenance Procedures .....	32
8.3	Diagnostics .....	33

8.3.1	Power-On Diagnostics.....	33
8.3.1.1	Power LED .....	33
8.3.1.2	Scan LED .....	33
8.3.1.3	Diagnostic LEDs .....	33
8.3.2	Run-Time Diagnostics.....	34
<b>9</b>	<b>MMC Connections to External Devices for Machine Control 35</b>	
9.1	PiCPro Port .....	35
9.2	Block I/O Port .....	36
9.3	User Port .....	37
9.4	General I/O Port .....	38
9.5	Power Connection .....	41
<b>10</b>	<b>MMC Analog Servo Connections for Motion Control .....43</b>	
10.1	Axis Connectors .....	43
10.2	Auxiliary I/O Connector .....	49
<b>11</b>	<b>MMC SERCOS Connections for Motion Control .....54</b>	
11.1	SERCOS Receive and Transmit Ports .....	54
11.2	Serial (Loader) Port .....	55
<b>12</b>	<b>Basic MMC Theory of Operation .....56</b>	
12.1	Machine Control Board Operation .....	56
12.2	LEDs .....	57
12.3	Diagnostic Error Codes .....	58
12.4	MMC Machine Control .....	59
12.5	Application in Flash .....	60
12.6	General I/O Output Operation .....	60
12.7	Protecting from an Inductive Load .....	61
12.8	DC Output Theory of Operation (Axis Connector) .....	62
12.9	DC Input Operation (Axis, AUX, General Connectors) .....	63
<b>13</b>	<b>Analog Servo Control Operation .....65</b>	
13.1	Analog Output Theory of Operation (Axis Connectors) .....	66
13.2	Encoder Theory of Operation (Axis and AUX Connectors) .....	66
13.3	Analog Input Operation (AUX Connector) .....	68
<b>14</b>	<b>MMC SERCOS Control Operation .....69</b>	
<b>15</b>	<b>Replacing the MMC Battery .....72</b>	
<b>16</b>	<b>Specifications <sup>TM</sup>.....74</b>	
<b>17</b>	<b>MMC Ethernet TCP/IP Module .....81</b>	
17.1	Introduction .....	81
17.2	Connections .....	82
17.2.1	The Ethernet Port .....	84
17.2.2	The RS232 COMM Ports .....	84
17.3	LEDs .....	85
17.4	Firmware Update .....	85

17.5 Theory of operation .....	86
17.6 Specifications Table .....	87
17.7 Useful Internet Links .....	88
<b>18 MMC DeviceNet Module .....</b>	<b>89</b>
18.1 Introduction .....	89
18.2 Connections .....	90
18.2.1 The DeviceNet Port.....	91
18.2.2 The Configuration (RS232) Port.....	91
18.3 LEDs .....	92
18.4 Theory of Operation .....	93
18.5 Specifications .....	94
<b>19 MMC Profibus Module .....</b>	<b>95</b>
19.1 Introduction .....	95
19.2 Connections .....	96
19.2.1 The Profibus Port .....	97
19.2.2 The Configuration (RS232) Port.....	97
19.3 LEDs .....	98
19.4 Theory of Operation .....	99
19.5 Specifications for Profibus Module .....	100
<b>20 Axis I/O Option Module .....</b>	<b>101</b>
20.1 Analog Output Theory of Operation (Axis Connectors) .....	101
20.2 Encoder Theory of Operation (Axis and AUX Connectors) .....	102
20.3 Analog Input Operation (AUX Connector) .....	104
20.4 Specifications .....	104
<b>21 Breakout Boxes, Centurion Connector Cables and Flying Lead Cables .....</b>	<b>107</b>
21.1 Breakout Boxes and Cables .....	109
21.1.1 Breakout Box and Cables for Axis Connector.....	110
21.1.1.1 Breakout Box for Axis Connector .....	111
21.1.1.2 Cable - Breakout Box to MMC Axis Connector .....	112
21.1.2 Breakout Box and Cables for Auxiliary I/O Connector.....	113
21.1.2.1 Breakout Box for AUX I/O Connector .....	113
21.1.2.2 Auxiliary I/O Connector Breakout Box with Encoder Isolators .....	116
21.1.2.3 Encoder Isolator Connections .....	117
21.1.2.4 Input Requirements for Encoder Isolator Breakout Box .....	118
21.1.2.5 Cable - Breakout Box to AUX I/O Connector .....	119
21.1.3 Breakout Box and Cables for Block I/O Connector.....	122
21.1.3.1 Block I/O Connector Breakout Box .....	122
21.1.3.2 Cable - Breakout Box to Block I/O Connector .....	124
21.1.4 Breakout Box and Cables for User Port Connector.....	125
21.1.4.1 User Port Connector Breakout Box .....	125

21.1.4.2 Cable - Breakout Box to User Port Connector .....	127
21.1.5 .....	Breakout
Box and Cables for General I/O Connector.....	128
21.1.5.1 Breakout Box for GEN I/O Connector .....	128
21.1.5.2 Cable - GEN I/O Connector to Breakout Box .....	130
21.2 Cables from Centurion Drives to MMC Axis Connector .....	132
21.2.1 Cable - DSM J1 Connector to MMC Axis Connector.....	132
21.2.2 Cable - MicroDSM J1 to MMC Axis Connector .....	134
21.3 Flying Lead Cables to MMC Control or Axis I/O Option Module .....	136
21.3.1 Flying Lead Cable to MMC or Axis I/O Option Module Connector	136
21.3.2 Flying Lead Cable to MMC or Axis I/O Option Module AUX I/O Connector	137
21.3.3 Flying Lead Cable to MMC BLK I/O Connector .....	140
21.3.4 Flying Lead Cable to MMC USER PORT Connector .....	141
21.3.5 Flying Lead Cable to MMC GEN I/O Connector .....	142
<b>22 CE and EMC Guidelines .....</b>	<b>145</b>
22.1 Background on EMC (Electromagnetic Compatibility) Compliance .....	145
22.2 Background on Low Voltage Compliance .....	145
22.3 RFI Emission and Immunity .....	146
22.4 Classes of EMC Operating Environments .....	147
22.5 Conformance with the EMC Directive .....	148
22.6 Conformance With the Low Voltage Directive .....	148
22.7 Changes to the PiC Products .....	148
22.7.1 Changes Affecting the User .....	149
22.8 Using CE/EMC and Non-CE/EMC Modules .....	152
22.9 Declarations of Conformity .....	154

## Index 1.IND-1



---

---

# 1 Safety Precautions

---

## **READ AND UNDERSTAND THIS SECTION IN ITS ENTIRETY BEFORE UNDERTAKING INSTALLATION OR ADJUSTMENT OF MMC CONTROL EQUIPMENT**

The advice contained in this section will help users to operate and maintain the equipment in a safe manner at all times.

**PLEASE REMEMBER THAT SAFETY IS EVERYONE'S RESPONSIBILITY**

### **1.1 System Safety**

The basic rules of safety set forth in this section are intended as a guide for the safe operation of equipment. This general safety information, along with explicit service, maintenance and operational materials, make up the complete instruction set. All personnel who operate, service or are involved with this equipment in any way should become totally familiar with this information prior to operating.

#### **1.1.1 User Responsibility**

It is the responsibility of the user to ensure that the procedures set forth here are followed and, should any major deviation or change in use from the original specifications be required, appropriate procedures should be established for the continued safe operation of the system. It is strongly recommended that you contact your OEM to ensure that the system can be safely converted for its new use and continue to operate in a safe manner.

#### **1.1.2 Safety Instructions**

1. Do not operate your equipment with safety devices bypassed or doors removed.
2. Only qualified personnel should operate the equipment.
3. Never perform service or maintenance while automatic control sequences are in operation.
4. To avoid shock or serious injury, only qualified personnel should perform maintenance on the system.

5. **ATTENTION - DANGER TO LIFE**  
Do not touch the main power supply fuses or any components internal to the power modules while the main power supply switch is ON. Note that when the main power switch is OFF, the incoming supply cable may be live.
6. **GROUNDING (Protective Earth)**  
The equipment must be grounded (connected to the protective earth connection) according to OEM recommendations and to the latest local regulations for electrical safety. The grounding (protective earth) conductor must not be interrupted inside or outside the equipment enclosures. The wire used for equipment grounding (connection to protective earth) should be green with a yellow stripe.
7. If there is any doubt at all as to the safety of the equipment, you should set the main power switch to OFF and contact your OEM for advice.

## **1.2 Safety Signs**

The purpose of a system of safety signs is to draw attention to objects and situations which could affect personal or plant safety. It should be noted that the use of safety signs does not replace the need for appropriate accident prevention measures. Always read and follow the instructions based upon the level of hazard or potential danger.

## 1.3 Warning Labels

### *Hazard warning*

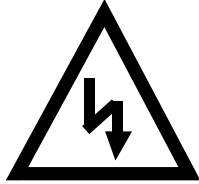

Danger Electric  
Shock Risk

When you see this safety sign on a system, it gives a warning of a hazard or possibility of a hazard existing. The type of warning is given by the pictorial representation on the sign plus text if used.

The safety color is black on a yellow background with a black symbol. To ignore such a caution could lead to severe injury or death arising from an unsafe practice. If voltage levels are included in the text they must indicate the maximum level of the hazard in normal or fault condition.

### *Danger, Warning, or Caution warning*



Symbol plus DANGER, WARNING or CAUTION: These notices provide information intended to prevent potential personal injury and equipment damage.

### *Hot Surface warning*

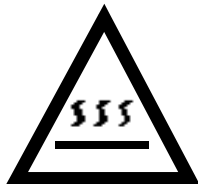

Hot Surface

## **1.4 Safety First**

G&L Motion Control equipment is designed and manufactured with consideration and care to generally accepted safety standards. However, the proper and safe performance of the equipment depends upon the use of sound and prudent operating, maintenance and servicing procedures by trained personnel under adequate supervision.

For your protection, and the protection of others, learn and always follow these safety rules. Observe warnings on machines and act accordingly. Form safe working habits by reading the rules and abiding by them. Keep these safety rules handy and review them from time to time to refresh your understanding of them.

## **1.5 Safety Inspection**

### **1.5.1 Before Starting Operations**

1. Ensure that all guards and safety devices are installed and operative and all doors which carry warning labels are closed and locked.
2. Ensure that all personnel are clear of those areas indicated as potentially hazardous.
3. Remove (from the operating zone) any materials, tools or other objects that could cause injury to personnel or damage the system.
4. Make sure that the control system is in an operational condition.
5. Make certain that all indicating lights, horns, pressure gauges or other safety devices or indicators are in working order.

## **1.6 After Shutdown**

Make certain all controlled equipment in the plant is safe and the associated electrical, pneumatic or hydraulic power is turned off. It is permissible for the control equipment contained in enclosures to remain energized provided this does not conflict with the safety instructions found in this section.

## **1.7 Operating Safely**

1. Do not operate the control system until you read and understand the operating instructions and become thoroughly familiar with the system and the controls.
2. Never operate the control system while a safety device or guard is removed or disconnected

3. Where access to the control system is permitted for manual operation, only those doors which provide that access should be unlocked. They should be locked immediately after the particular operation is completed.
4. Never remove warnings that are displayed on the equipment. Torn or worn labels should be replaced.
5. Do not start the control system until all personnel in the area have been warned.
6. Never sit or stand on anything that might cause you to fall onto the control equipment or its peripheral equipment.
7. Horseplay around the control system and its associated equipment is dangerous and should be prohibited.
8. Know the emergency stop procedure for the system.
9. For maximum protection when carrying out major servicing requiring the system to be powered down, the power source should be locked using a lock for which only you have the key. This prevents anyone from accidentally turning on the power while you are servicing the equipment.
10. Never operate the equipment outside specification limits.
11. Keep alert and observe indicator lights, system messages and warnings that are displayed on the system.
12. Do not operate faulty or damaged equipment. Make certain proper service and maintenance procedures have been performed.

## **1.8 Electrical Service & Maintenance Safety**

1. **ALL ELECTRICAL OR ELECTRONIC MAINTENANCE AND SERVICE SHOULD BE PERFORMED BY TRAINED AND AUTHORIZED PERSONNEL ONLY.**
2. It should be assumed at all times that the POWER is ON and all conditions treated as live. This practice assures a cautious approach which may prevent accident or injury.
3. To remove power:  
**LOCK THE MAIN SWITCH IN THE OPEN POSITION.  
USE A LOCK TO WHICH ONLY YOU HAVE THE KEY.**
4. Make sure the circuit is safe by using the proper test equipment. Check test equipment regularly
5. Capacitors take time to discharge. Care should be taken in manual discharging of capacitors

6. There may be circumstances where troubleshooting on live equipment is required. Under such conditions, special precautions must be taken:
  - Make sure your tools and body are clear of the areas of equipment which may be live.
  - Extra safety measures should be taken in damp areas.
  - Be alert and avoid any outside distractions.
  - Make certain another qualified person is in attendance.
7. Before applying power to any equipment, make certain that all personnel are clear of associated equipment.
8. Control panel doors should be unlocked only when checking out electrical equipment or wiring. On completion, close and lock panel doors.
9. All covers on junction panels should be fastened closed before leaving any job.
10. Never operate any controls while others are performing maintenance on the system.
11. Do not bypass a safety device.
12. Always use the proper tool for the job.
13. Replace the main supply fuses only when electrical power is OFF (locked out).

## **1.9 Safe Cleaning Practices**

1. Do not use toxic or flammable solvents to clean control system hardware.
2. Turn off electrical power (lock out) before cleaning control system assemblies.
3. Keep electrical panel covers closed and power off when cleaning an enclosure.
4. Always clean up spills around the equipment immediately after they occur.
5. Never attempt to clean a control system while it is operating.
6. Never use water to clean control equipment unless you are certain that the equipment has been certified as sealed against water ingress. Water is a very good conductor of electricity and the single largest cause of death by electrocution.

---

---

## 2 Introduction

---

This document contains information for the MMC hardware. Block I/O information can be found in the PiC900 Hardware Manual. Software information can be found in the PiCPro online help, the Function/Function Block Reference Guide, ASFB Manuals or on-line.

### 2.1 Overview

The MMC Control offers a complete solution to both machine and motion control in a stand-alone unit. The MMC family includes these models:

- MMC-A2 (2 1/2 axis analog servo control)
- MMC-A2 Plus (2 1/2 axis analog servo control, expandable)
- MMC-A4 (4 1/2 axis analog servo control)
- MMC-A4 Plus (2 1/2 axis analog servo control, expandable)
- MMC-S8 (8 axis SERCOS control)

The PiCPro programming tool used with the PiC family of controls is also used to program the MMC. The built-in I/O [28 inputs (24 VDC) and 16 outputs (24 VDC)] can be expanded using G&L Motion Control serially distributed block I/O. There are also eight (four) low current DC and four (two) DC inputs on the Axis connectors of the MMC-A4 and MMC-A2.

Field-installable options for the MMC include an Ethernet TCP/IP interface and a DeviceNet™ master interface.

### 2.2 Major Components

The major components of an MMC Control include a Machine Control board and a Motion Control board contained within a metal enclosure.

Related external connections for the boards are located on the face of the enclosure.

Add-on communications and analog axis I/O modules are also available to connect to the MMC Control.

With the MMC-A2 and A-4 you can add 2 communications modules (Ethernet, Profibus, or DeviceNet).

With the MMC-A2 Plus and A-4 Plus you can add up to 4 analog Axis I/O option modules and 2 communication modules (Ethernet, Profibus or DeviceNet) but the total number of option modules cannot exceed 4.

Figure 1: The MMC Control Units

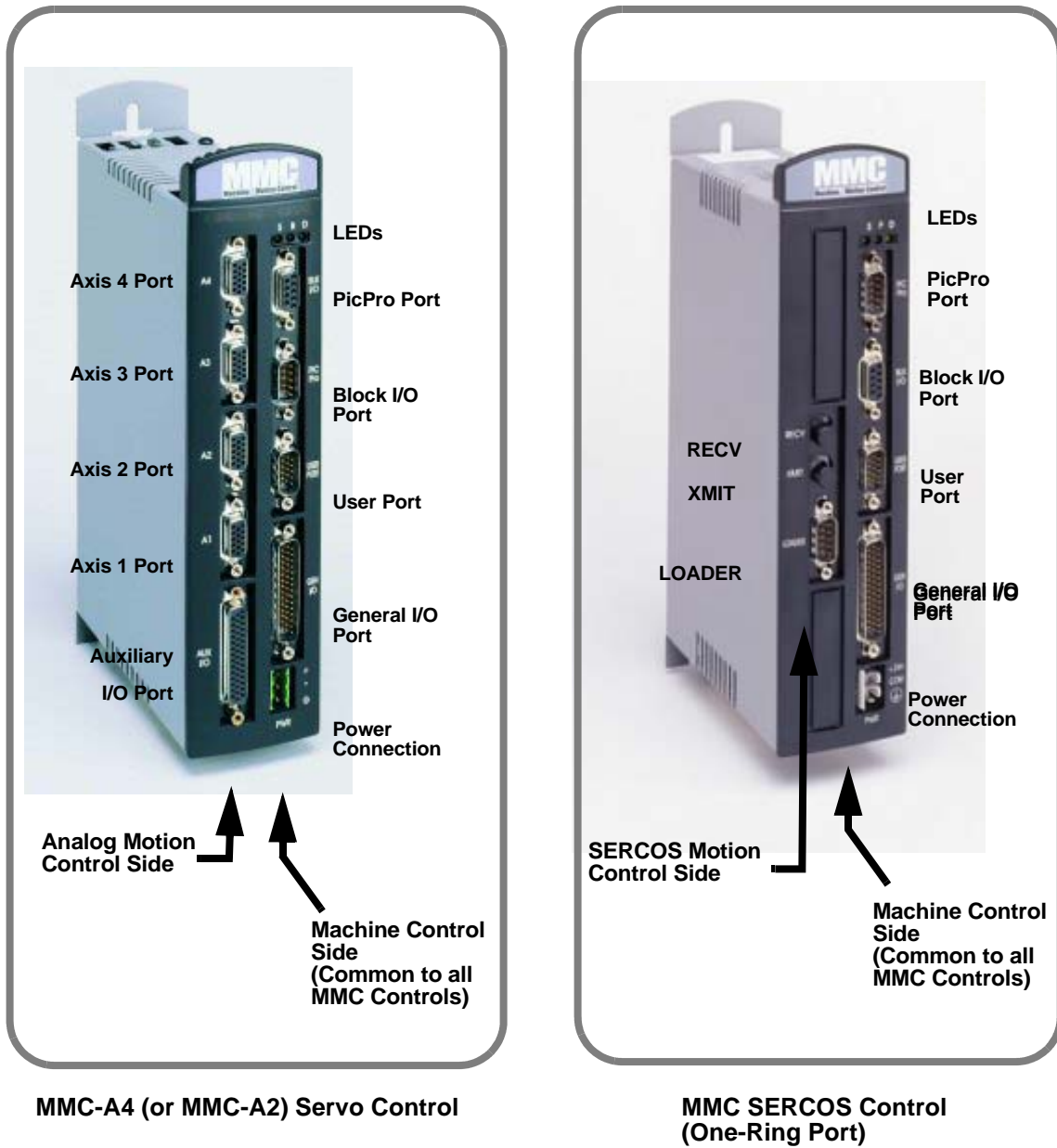



## 2.2.1 Machine Control Board

A Machine Control Board and its related external connections are located on the right side of the control. The Machine Control Board contains the CPU. Ladder logic programming is used for machine control. This board also provides the PiCPro serial interface port, block I/O interface port, user serial interface port and a general I/O port consisting of 16 DC outputs and 16 DC inputs

**Table 1: Available I/O - Machine Control**

Available I/O	2 1/2 Axis	4 1/2 Axis
GEN I/O Port DC Inputs	16	16
GEN I/O Port DC Outputs	16	16

## 2.2.2 Motion Control Board

A Motion Control Board and its related external connections are located on the left side of the control. The motion control side of the MMC unit can be either an Analog Servo board or a SERCOS board.

### 2.2.2.1 Analog Servo board

The Analog Servo board provides conventional analog/digital interfacing for two or four drives.

The typical signals needed to interface to an analog drive are provided by the analog servo module. The drive command is in the form of an analog voltage ( $\pm 10V$ ). Feedback is accepted from quadrature type encoders with differential outputs. Digital I/O (+24 VDC) is used for drive signals enable, reset, and fault.

The analog servo board is offered in both 2 1/2 and 4 1/2 axis configurations. An axis is considered to be an analog output with a corresponding encoder input. In each configuration shown in the following table, note that there is an extra encoder input. This is referred to as a half axis.

**Table 2: Available I/O Analog Servo Board**

<b>Available I/O</b>	<b>2 1/2 Axis</b>	<b>4 1/2 Axis</b>
Analog Inputs	1	1
Analog Outputs	2	4
Encoder Inputs	3	5
Axis DC Inputs	2	4
Axis DC Outputs	4	8
Axis Fast DC Inputs	3	5
AUX I/O Port DC Inputs	6	12

**2.2.2.2 SERCOS board**

The SERCOS Motion Control board provides a fiber optic input and output for one SERCOS ring. There is also a serial port for field upgrades of the board processor's FLASH memory.

### 2.2.3 Option Modules

Optional communications and Axis I/O modules provide additional axis control or special functions such as an Ethernet or DeviceNet interface (Analog Axis I/O option modules only for use with MMC Plus). Figure 2 below depicts an option module connected to an MMC Control.

**Figure 2: Option Module Connected to MMC Control**

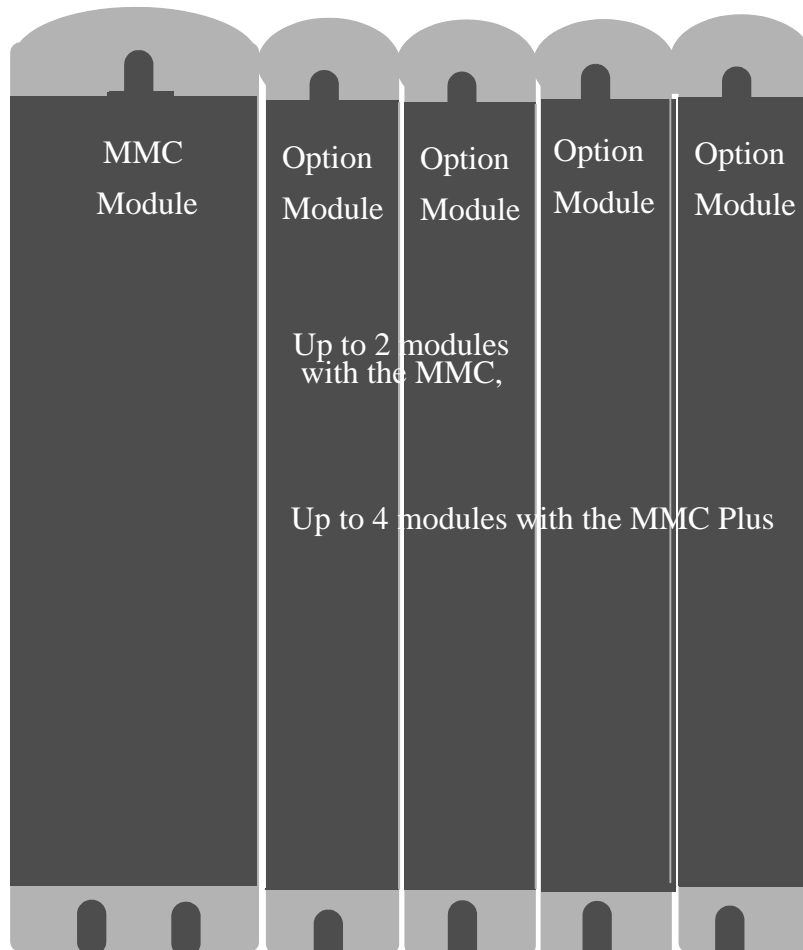

**NOTES**

### 3 Mounting the MMC Control

Mount the unit to your cabinet using the mounting slots on the MMC. The MMC unit may be mounted vertically or horizontally. The recommended size of mounting hardware is #10 bolts with #10 star washers (to ensure proper ground connection) as shown in Figure 3 below.

Figure 3: MMC Mounting Dimensions

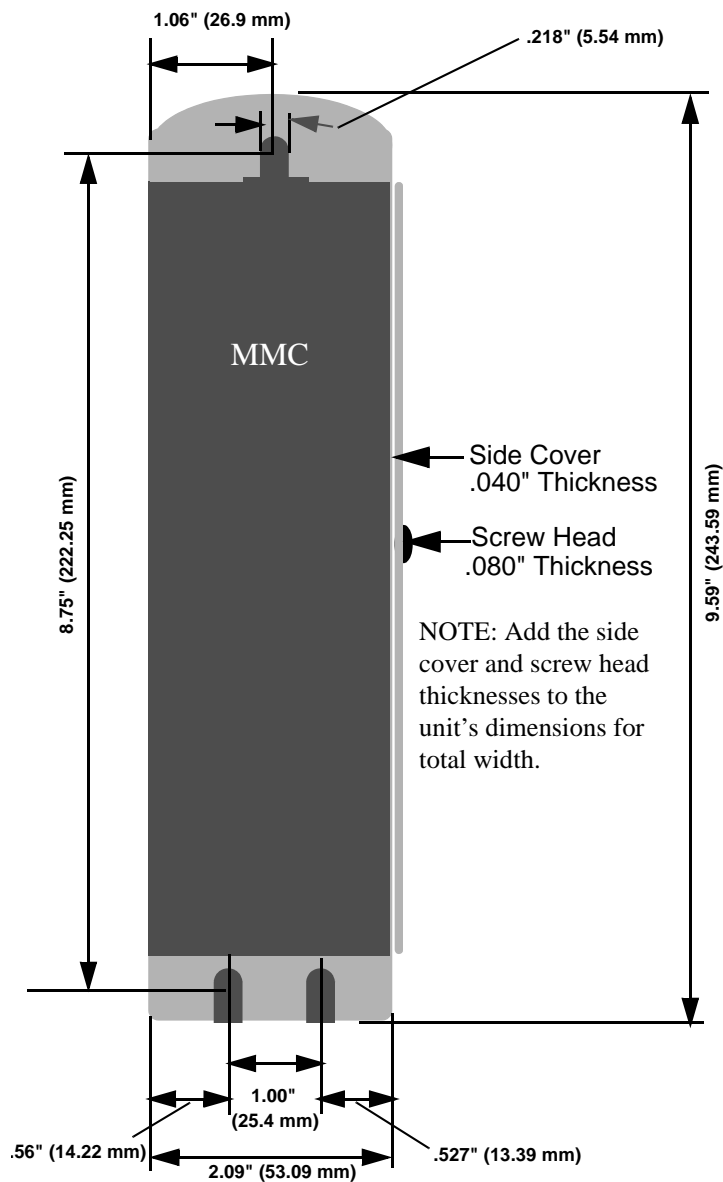

**NOTES**

---

---

## 4 Adding an Option Module to the MMC Control

---

---

Option modules are shipped with a 50-pin square post connector and screws needed to attach the module to the MMC (or to another option module). Follow the procedure below to add an option module to the MMC (or to another option module). Procedures are the same for the MMC A-2 Servo Control, MMC A-4 Servo Control and the MMC SERCOS Control Unit.

1. Place the MMC and the option module on a static free surface. Ground yourself using a properly grounded wrist strap before you begin. These are standard precautions before handling any electronic components.
2. Remove the five screws securing the MMC cover using a #1 Phillips screwdriver and set them aside. There are two screws on the top, two screws on the bottom, and one screw on the side of the module.

**Figure 4: Location of Screws on MMC (MMC A-4 Servo Unit Shown)**



### *Adding an Option Module to the MMC Control*

3. Lift the side cover off and set aside.
4. Locate the 50-pin square post socket at the top of the MMC board. Press one side of the 50-pin square post male connector into this socket ensuring that the pins are aligned and it is firmly seated.
5. Pick up the option module. Line up the socket on the option module with the male end of the connector extending from the MMC ensuring that the pins are aligned. Press firmly into place. Be sure to align the screw tabs on the top and bottom of the option module with the screw slots on the top and bottom of the MMC module so that the modules slide together easily.
6. Screw four screws (of the five included in your package) into the screw tabs to attach the option module to the MMC.
7. Lay the unit on the bench. Place the cover you set aside in Step 3 on the option module. Be sure to align the screw tabs on the top and bottom of the cover with the screw slots on the top and bottom of the option module.
8. Screw the five screws removed in Step 2 back into place to secure the cover.



## 5 Dimensions and Mounting of MMC with Option Module Attached

After attaching the option module to the MMC module, mount the unit to your cabinet using the mounting slots on the MMC and the option module. The recommended size of mounting hardware is #10 bolts with #10 star washers (to ensure proper ground connection).

**Figure 5: MMC Mounting Dimensions with 2 Option Modules Attached**

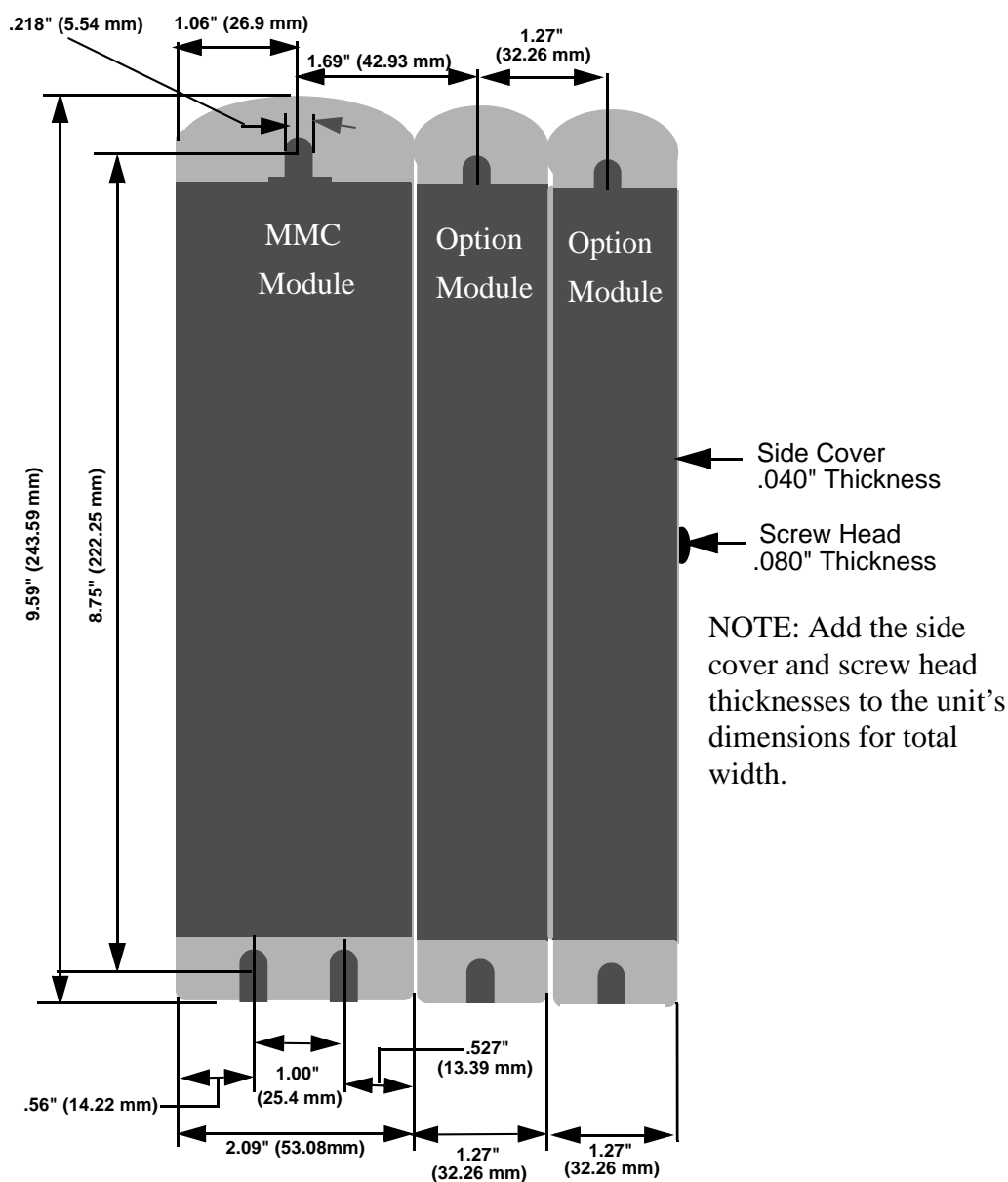

**NOTES**

---

---

## 6 System Power and Environment Requirements

---

### 6.1 General Power and Environment Requirements

The MMC is suitable for operation in a pollution degree 2 environment (i.e., normally, only non-conductive pollution occurs). You are not required to install the system rack in a control cabinet. However a cabinet protects the system from dust and mechanical damage and is recommended.

Power distribution is shown in Figure 6 on page 20. Install the system rack away from all sources of strong electromagnetic noise. Such noise can interfere with MMC operation.

Protect the MMC system from all the following:

- conductive fluids and particles
- corrosive atmosphere
- explosive atmosphere

The diagrams and recommendations may be modified if necessary so the wiring conforms to current NEC standards or government regulations.

### 6.2 Control Cabinet Specifications

1. A control cabinet for the MMC should have a NEMA-12 rating or better. A cabinet with this rating protects its contents from dust and mechanical damage.
2. It must be large enough to provide adequate air circulation for the MMC, drives, and other components. Always allow for adequate air flow through the MMC vents.
3. It must have a rigid vertical surface to mount the MMC on.
4. The door should open fully for easy access.

IMPORTANT
Post warnings according to National, State, or local codes for the voltage present in the control cabinet.

## 6.3 Power Distribution Diagram

The MMC requires an external DC power source. The power distribution drawing that follows shows an MMC connected to a  $\mu$ DSM Drive. The drive's 24 VDC power is supplied via the MMC in this example. If the drive has its own external 24 VDC supply, the +24 V line would not be connected.

**Figure 6: Example of 24 VDC Power Distribution to an MMC System**

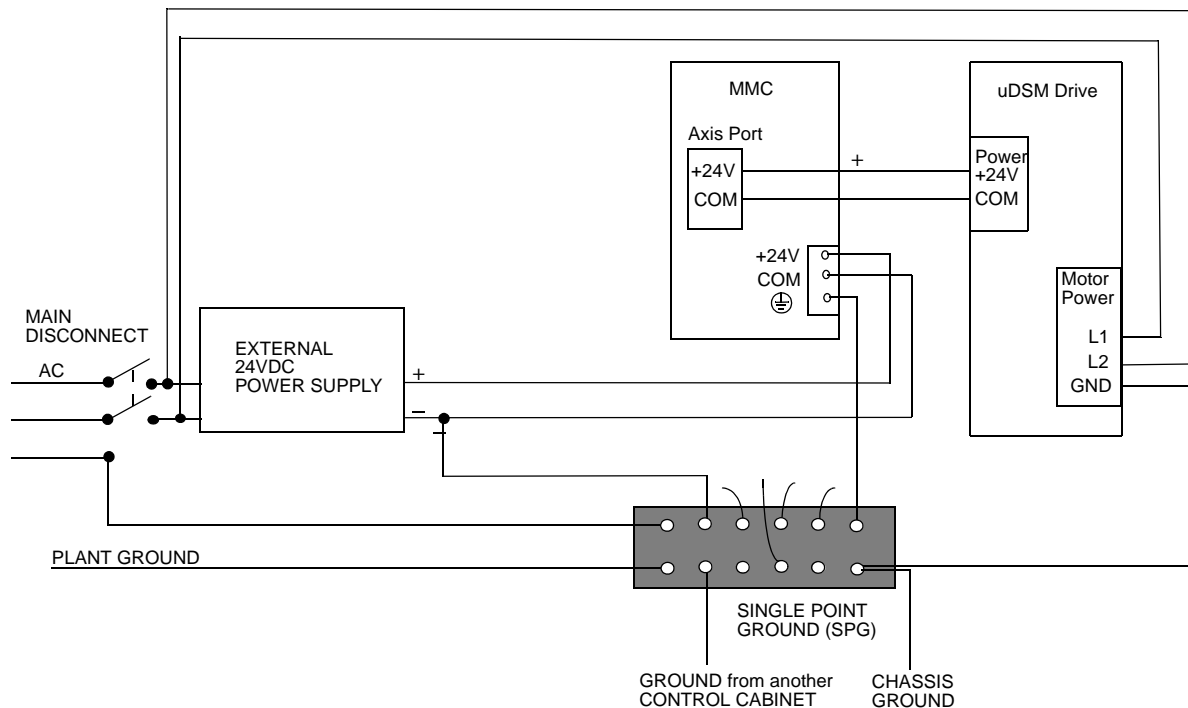

The DC power source is connected to the MMC system through a 3-pin connector. It plugs into the power connector of the MMC. The ground from the power source and ground from the MMC must be connected to the Single-Point Ground (SPG).

Devices connected to the hardware may have their own power sources for input data or output control signals. You can use other wiring setups, provided that each one is:

- at the correct voltage and current levels for the module and the device.
- connected to the same Single-Point Ground that the MMC uses.

It is recommended that the same main disconnect switch be used for the MMC system and for all devices in the application.

**IMPORTANT**

No matter how the system is installed, before you connect the MMC to the application, make sure that power is off to the system and to the devices that are wired to the MMC.

## 6.4 Notes for 24V Power Supply and MMC

An MMC system consists of a main module (servo analog or SERCOS based) and up to four option modules. An external 24 VDC supply is required to power the MMC's internal circuitry and external I/O. The 24 VDC is distributed internally to three different buses or sections. When you size your power supply, you must ensure that the supply is large enough to handle the total load and that the maximum current capability of each bus is not exceeded. Table 3 below shows the distribution of the 24 VDC power within the MMC system:

**Table 3: MMC 24VDC Power Distribution**

Power Bus	Supplying Current To:	Maximum Current
1	Module Circuitry	3 A
2	General I/O	5 A
3	Module I/O	1 A

In most cases, one power supply can be used for the entire control system. However, depending upon the modules, drives, and external I/O used in your application, you may split the power distribution into two or more power supplies. For example, the Axis I/O on an MMC A2 module can be powered from the MMC, from the drive, or from another external power supply.

**CAUTION**

A possible ignition hazard within the MMC exists if the maximum currents listed for Bus 2 or Bus 3 are exceeded or if excessive current is drawn at the 24 V line going into the MMC. If these currents might be exceeded (due to improper wiring or external device failure), circuit breakers or fuses should be used in series with the 24 VDC going to and coming from the MMC. Specifically, the circuit breakers or fuses should be sized for 10 A total on the 24V line coming into the MMC, 1 A total from the +24 VDC OUT pins of the AXIS and AUXILIARY I/O connectors, and 5 A total from the I/O 24V pins of the GENERAL I/O connector. For maximum protection, use fast blow fuses. When using molded cables supplied by G&L Motion Control to connect the MMC to the drives, no overload protection is required.

Refer to Table 4 to size the power supply required by your application.

**Table 4: 24 VDC Power Supply Sizing Worksheet**

Line	MMC Module	Current (mA)	# of Units	Col A Subtotal (mA)	Col B Current (mA)
1	MMC-A2 or MMC-A4 ( PLUS)	250 (450)			
2	MMC SERCOS ( PLUS)	300 (500)			
3	Axis I/O Option Module	100			
4	MMC Ethernet Option Module	200			
5	MMC DeviceNet Option Module	100			
6	Subtotal, Power Bus 1 (Add Column A (3000 mA max))				

Line	MMC Component (Lines 7-12 are for General I/O Port, Lines 14-21 are for Axis I/O Ports)	Max Current (mA)	Actual Current (mA)	Number of I/O	Col A Subtotal (mA)	Col B Current (mA)
7	General Inputs	7.5	7.5			
8	General Outputs	250				
9		250				
10		250				
11		250				
12		250				
13	Subtotal, Power Bus 2 (Add Column A, Lines 7-12, 5000 mA max)					
14	Axis inputs	7.5	7.5			
15	Axis outputs	100				
16		100				
17		100				
18		100				
19	Auxiliary inputs	7.5	7.5			
20	Fast inputs	7.5	7.5			
21	Current supplied by AUX +24 VDC Out pins					
22	Subtotal Power Bus 3 (Add Column A, Lines 14-21, 1000 mA max)					
23	MMC Power (Add Column B, Lines 6, 13, and 22, 10,000 mA max)					
24	Other (i.e. block I/O)					
25						
26						
27	Subtotal (Add Column A, Lines 24-26)					
28	Total Power (Add Column A, Lines 23 and 27)					

Refer to Table 5 to calculate the maximum current required for a theoretical 4 axes MMC.

**Table 5: 24 VDC Power Supply Sizing Example**

Line	MMC Module	Current (mA)	# of Units	Col A Subtotal (mA)	Col B Current (mA)
1	MMC-A2 or MMC-A4 ( PLUS)	250 (450)	1	250	
2	MMC SERCOS ( PLUS)	300 (500)			
3	Axis I/O Option Module	100			
4	MMC Ethernet Option Module	200			
5	MMC DeviceNet Option Module	100			
6	Subtotal, Power Bus 1 (Add Column A (3000 mA max))				250

Line	MMC Component (Lines 7-12 are for General I/O Port, Lines 14-21 are for Axis I/O Ports)	Max Current (mA)	Actual Current (mA)	Number of I/O	Col A Subtotal (mA)	Col B Current (mA)	
7	General Inputs	7.5	7.5	16	120		
8	General Outputs	250	200	5	1000		
9		250	100	9	900		
10		250					
11		250					
12		250					
13	Subtotal, Power Bus 2 (Add Column A, Lines 7-12, 5000 mA max)					2020	
14	Axis inputs	7.5	7.5	4	30		
15	Axis outputs	100	50	8	200		
16		100			100		
17		100			60		
18		100					
19	Auxiliary inputs	7.5	7.5		120		
20	Fast inputs	7.5	7.5	6	45		
21	Current supplied by AUX +24 VDC Out pins				400		
22	Subtotal Power Bus 3 (Add Column A, Lines 14-21, 1000 mA max)						955
23	MMC Power (Add Column B, Lines 6, 13, and 22, 10,000 mA max)				3225		
24	Other (i.e. block I/O)						
25							
26							
27	Subtotal (Add Column A, Lines 24-26)				0		
28	Total Power (Add Column A, Lines 23 and 27)					3225	

## 6.5 Grounding the System

The ground of the MMC power source must be connected directly to a *Single Point Ground* (SPG) tie block. The tie block should be made of brass or copper, bolted or brazed to the control cabinet. If the tie block is bolted rather than brazed, scrape away paint or grease at the point of contact. Put star washers between the tie block and the cabinet to ensure good electrical contact.

Metal enclosures of power supplies, drives, etc., should also have good electrical contact with the SPG.

### CAUTION

The Single Point Ground should be the only common point for all the ground lines. If not, ground loops may cause current flow between components of the system which can interfere with proper operation of the MMC.

Devices to be connected directly to the Single Point Ground include:

- Plant safety ground.
- Chassis ground from MMC power connector.
- The metal panel or cabinet on which the MMC is mounted.
- "Common" or "0 V" lines from power supplies that provide external power to the I/O modules and the devices to which they are connected.
- Chassis grounds from the devices themselves, such as device drivers, machinery, and operator interface devices.
- AC common line from the noise filter, if any.
- The ground of the power source of the computer workstation, if any, from which you monitor the system operation. An AC outlet in the control cabinet is recommended.
- Single point grounds from other control cabinets, if any, in the system.



**IMPORTANT**

You must ensure that the "0V" or "Common" of all devices connected to the MMC are connected to Single Point Ground (SPG). Failure to do so may result in erratic operation or damage to the MMC. Examples of devices connected to the MMC include the power source that supplies 24VDC power to the MMC and devices connected to the MMC PiCPro Port or User Port. Note that some devices (for example, a Personal Computer) may have their "0V" and "Chassis" connected together internally, in which case only one connection has to be made to SPG for that device.

Also, you must ensure that the MMC "Chassis connection is connected to SPG, and that the MMC is mounted to a metal panel or enclosure that is connected to SPG.

## 6.6 Controlling Heat Within the System

The MMC hardware case is designed to promote air circulation and dissipate heat. The MMC can be mounted vertically or horizontally to take advantage of this design. Normally no fans or air conditioners are needed. However, if the environment outside the control cabinet is hot or humid, you may need to use a fan, heat exchanger, dehumidifier or air conditioner to provide the correct operating environment.

**Table 6: Operating Limits for the MMC**

Temperature	5 to 55° C (41 to 131° F)
Relative humidity	5 to 95%, non-condensing

Make sure that components installed in the cabinet with the MMC do not raise the temperature above system limits and that any hot spots do not exceed specifications. For example, when heat-generating components such as transformers, drives or motor controls are installed, separate them from the system by doing one of the following:

- Place them near the top of the control cabinet so their heat output rises away from the MMC.
- Put them in another control cabinet above or to one side of the cabinet with the MMC. This protects the MMC from both heat and electrical noise.

The MMC itself is a source of heat, though in most installations its heat dissipates without harmful effects. System heat is generated from power dissipated by:

- field side input/output components
- other components within the MMC

**CAUTION**

If the MMC is operated outside the recommended limits, it may be damaged. This will void the warranty.

## **6.7 Handling an MMC**

The case protects the MMC's internal circuitry against mechanical damage in shipping and handling. However, like any electronics device, the circuitry can be destroyed by:

- temperatures over 55° C (131° F)
- moisture condensing inside the module
- static discharge
- exposure to a magnetic field strong enough to induce a current in the circuitry
- freezing temperatures, vibration, and other hazards

Normally there is no need to open the case. Occasionally, a battery must be replaced. A diagram and detailed anti-static precautions in the appendices are included with modules that have replaceable components.

## 7 System Wiring Guidelines

The MMC relies on electrical signals to report what is going on in the application and to send commands to it. In addition, signals are constantly being exchanged within the system. The MMC is designed for use in industrial environments, but some guidelines should be followed.

### 7.1 Recommended Signal Separation

G&L Motion Control continues to recommend separation of low level signals (encoder, analog, communications, fast DC inputs) from high voltage or high current lines. Maintain at least one inch of separation around signals.

Figure 7 below illustrates the recommended connections when using EMC compliant products. Note that a capacitor is connected to the 24 VDC supply. To prevent excessive conducted emissions from a DC power source (typically 24 V) used for digital I/O, a 1000 picofarad capacitor should be used. Connect the capacitor from the +24 VDC to COMMON at the distribution terminals.

**Figure 7: Recommended EMC Compliant Connections**

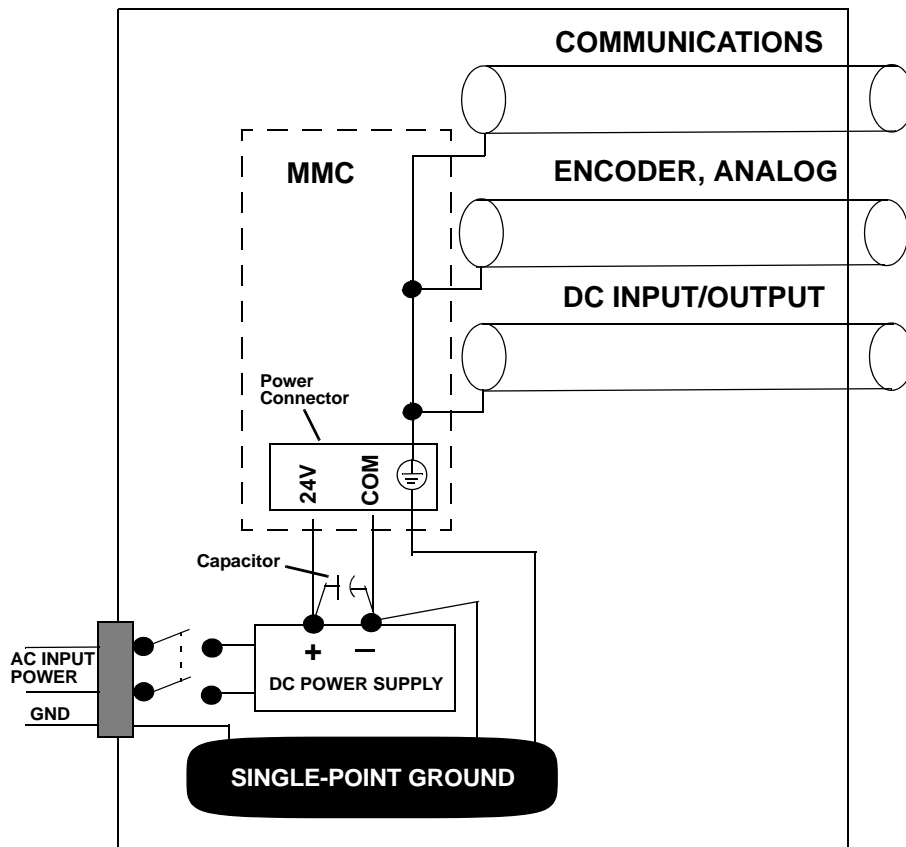

Inside a control cabinet, connect the shields of shielded cables at the MMC. Figure 8 below illustrates shielded cable entering/leaving the cabinet.

**Figure 8: Connecting Shielded Cable**

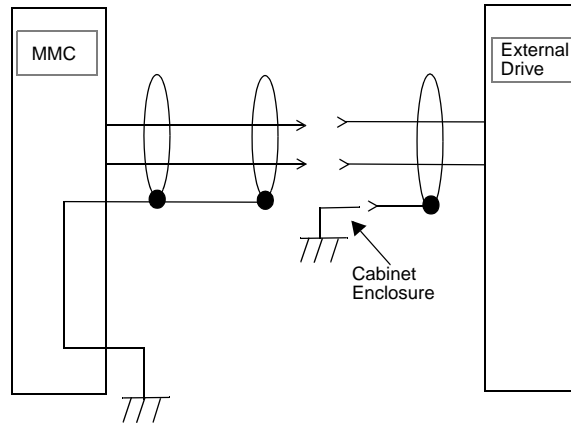

The two different methods of terminating shields are used to accommodate two different immunity requirements. Immunity required inside an enclosure is considered lower because cables are typically less than three meters in length and/or can be separated from each other and from noise sources.

Immunity required external to an enclosure is considered higher because the user may have less control over the noise environment. Low level signal cables that can be external to an enclosure are tested at a 2 KV level for electrical fast transients (EFTs). Low level signals that can be less than three meters in length or can be separated from noise sources are tested at a 1 KV level. Under the stated conditions, there will be no disturbance of digital I/O, encoder, or encoder operation. For analog signals, there may be momentary disturbances but there will be self-recovery when the noise subsides.

Do not operate transmitters, arc welding equipment, or other high noise radiators within one meter of an enclosure that has the door open. Continue to equip inductive devices, if they are in series with a mechanical contact or switch, with arc suppression circuits. These devices include contactors, solenoids and motors. Shield all cables that carry heavy current near the system, using continuous foil wrap or conduit grounded at both ends. Such cables include power leads for high-frequency welders and for pulse-width-modulated motor drives.

**WARNING**

Use care when wiring I/O devices to the MMC and when plugging in cables. Wiring the wrong device to the connector or plugging a connector into the wrong location could cause intermittent or incorrect machine operation.

## 7.2 Differential Devices for Analog and Encoder Signals

A *differential* device receives or sends one signal over two wires (typically a shielded twisted pair). The input/output voltage at the second terminal is the inverse of the first. Information is received/sent as the difference between the two voltages.

**Figure 9: Differential Digital Pulse Train**

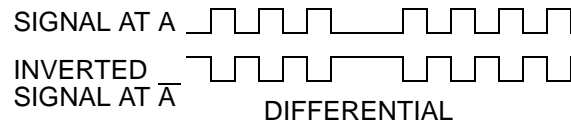

The advantages of using differential signals are:

1. A differential signal is less susceptible to electromagnetic noise. Static or other interference affects both of the twisted-pair wires equally, so the difference between the normal and inverted voltage remains unchanged. A differential signal can be transmitted over a much longer distance or in a much noisier environment than a single-ended one.
2. MMC hardware circuitry can detect signal loss from an encoder if the signal is differential. The application program can be set to shut down the application if such an error is detected.

### IMPORTANT

Always use differential drivers or differential inputs.

**NOTES**

---

---

## **8 Starting an Operation**

---

Good procedure suggests that the system should be tested each time a new application is powered up. The DIAG LED on the MMC should be off indicating that the diagnostic tests were passed.

Turn off the main disconnect switch and plug the DC connector into the power connector. Turn on input power. The DIAG LED turns on and then turns off when the MMC passes its diagnostic tests.

### **8.1 Connecting the MMC to the Application**

1. Turn off the main disconnect switch in the control cabinet. If some devices are not powered from the control cabinet, turn them off also.
2. Connect the connectors according to your diagrams.
3. Turn on power to the system. The PWR light goes on and stays on. The DIAG light goes on, then goes off in turn. The SCAN light goes on. The application starts to work under control of the system.
4. If an application program is not in system memory, use the download command in the PiCPro software to place it there.

## 8.2 Basic Setup and Maintenance Procedures

Table 7 below summarizes how to proceed when performing certain maintenance and/or setup functions.

**Table 7: Troubleshooting Summary**

<b>In order to:</b>	
Turn off the entire application.	Turn off main disconnect (which should also turn off all external power supplies to the application); unplug the DC power to the MMC.
Wire the I/O to the application.	Turn off main disconnect (which should also turn off all external power supplies to the application); unplug the DC power to the MMC.
Change the battery.	Turn off main disconnect (which should also turn off all external power supplies to the application); unplug the DC power to the MMC.
Connect/disconnect the MMC with the computer workstation through the PiCPro port.	Turn off main disconnect (which should also turn off all external power supplies to the application); unplug the DC power to the MMC.
Connect/disconnect the MMC with an operator interface through the User port.	Turn off main disconnect (which should also turn off all external power supplies to the application); unplug the DC power to the MMC.
Download an application program into the memory.	Make sure power is on (check the <b>P</b> LED).
Stop the scan.	From the workstation - use the Stop Scan commands in the PiCPro software.



## **8.3 Diagnostics**

This section covers two types of diagnostics; power-on and run-time.

### **8.3.1 Power-On Diagnostics**

When the system is powered up, it tests itself and reports the results of the tests in the form of LED signals.

#### **8.3.1.1 Power LED**

If the power light (P) does not go on, or goes off during operation of the system, check that power is still connected to the MMC. If it is, turn off the main disconnect switch and replace the MMC.

#### **8.3.1.2 Scan LED**

If the SCAN LED does not go on:

1. Check that the power (P) light is ON.
2. Check that the diagnostic (D) light is OFF.

#### **8.3.1.3 Diagnostic LEDs**

The MMC has an LED marked D which lights up briefly while its diagnostic tests are running and then goes off. If the DIAG LED remains on, the MMC has failed one of its tests. Follow these steps:

1. Turn off power to the system and to the application.
2. If the I/O wiring is connected, remove the connector .
3. Remove the defective MMC from the system
4. Replace with a new MMC. Connect the I/O wiring.
5. Turn on power to check diagnostics again.

**NOTE**

Diagnostics are run only when the system is powered up. It is possible that a failure might occur during operation. If so, its DIAG light remains off. If you suspect that a module might be defective, cycle power to run diagnostics again.

### **8.3.2 Run-Time Diagnostics**

While the MMC is running, other tests are performed on a regular basis with their results also reported by LEDs.

- If the POWER (P) LED on the MMC starts flashing, the battery must be replaced. Follow the battery replacement procedure in this document.
- While the MMC is running, the DIAG LED will flash a three digit code signal if there is an error. For example, if there is a long pause-flash-pause-flash-flash-pause-flash-flash-flash-long pause, the code is 123. The errors are described in the LED section of this document.

## 9 MMC Connections to External Devices for Machine Control

G&L Motion Control provides many optional accessories that simplify wiring the MMC to external devices. These accessories include cables to connect the MMC to G&L Motion Control's line of DSM and Micro DSM drives and breakout boxes that provide screw-terminal connections to the MMC. Consult the factory for further information.

### 9.1 PiCPro Port

The PiCPro port provides serial communication for the PiCPro programming interface. Pinouts for the PiCPro Port are provided in Table 8.

**Table 8: Pinouts for PiCPro Port**

Pin	Description	In/Out
1	NC	
2	Receive Data	In
3	Transmit Data	Out
4	Data Terminal Ready	Out
5	Signal Ground	In/Out
6	NC	
7	Request to Send	Out
8	NC	
9	NC	

The pinout for a typical PiCPro Port cable is provided in Table 9.

**Table 9: Pinout for PiCPro Port Cable**

#### PiCPro Cable Pinout

9-pin female (to PC)		9-pin female (to PiCPro Port)
3	to	RD 2
2	to	TD 3
5	to	GND 5

## 9.2 Block I/O Port

The block I/O port provides:

- Up to 77 expansion block I/O units
- 4-wire communication interface
- Up to 200 feet between block I/O units

**Table 10: Pinout for Block I/O Port**

Pin	Description	In/Out
1	NC	
2	NC	
3	Block I/O Transmit Data +	Out
4	Block I/O Transmit Data -	Out
5	Block I/O Receive Data +	In
6	Block I/O Receive Data -	In
7	Shield (see Note below)	
8	NC	
9	NC	

**NOTE**

Pin 7 of the Block I/O port connector is connected to the connector shell within the MMC. Therefore, the shield may be connected to either pin 7 or the connector shell.

### 9.3 User Port

The User Port is used to communicate with a touch-screen, a hand-held controller, or other serial interface device. The user port provides:

- RS232/RS485 communication
- Baud rates to 19.2 K
- Multidrop capability

**Table 11: Pinout for User Port**

Pin	Description	In/Out	Pin	Description	In/.Out
1	NC		9	RS232 Receive Data	In
2	NC		10	RS232 Transmit Data	Out
3	+5V (50mA Max)	Out	11	NC	
4	RS232 Data Terminal Ready	Out	12	RS485 Receive Data +	In
5	RS232 Request to Send	Out	13	RS485 Receive Data -	In
6	NC		14	RS485 Transmit Data +	Out
7	RS232 Clear to Send	In	15	RS485 Transmit Data -	Out
8	Signal Ground	In/Out			

## 9.4 General I/O Port

The general I/O port includes:

- 16-24 VDC inputs
  - Sink or source in groups of eight (Inputs 1 and 9 can trigger an interrupt on the rising or falling edge)
- +24 VDC and 24 V Common
- 16-24 VDC outputs
  - Source only
  - 250 mA output capacity
  - Short circuit protection

**Table 12: Pinout for General I/O Port**

Pin	Description	In/Out	Pin	Description	In/Out	Pin	Description	In/Out
1	DCOUT1	Out	16	DCOUT16	Out	31	NC	
2	DCOUT2	Out	17	NC		32	NC	
3	DCOUT3	Out	18	NC		33	NC	
4	DCOUT4	Out	19	NC		34	IO24V	Out
5	DCOUT5	Out	20	IO24V	Out	35	DCSS2	In
6	DCOUT6	Out	21	DCSS1	In	36	IO24C	Out
7	DCOUT7	Out	22	IO24C	Out	37	DCIN9	In
8	DCOUT8	Out	23	DCIN1	In	38	DCIN10	In
9	DCOUT9	Out	24	DCIN2	In	39	DCIN11	In
10	DCOUT10	Out	25	DCIN3	In	40	DCIN12	In
11	DCOUT11	Out	26	DCIN4	In	41	DCIN13	In
12	DCOUT12	Out	27	DCIN5	In	42	DCIN14	In
13	DCOUT13	Out	28	DCIN6	In	43	DCIN15	In
14	DCOUT14	Out	29	DCIN7	In	44	DCIN16	In
15	DCOUT15	Out	30	DCIN8	In			

There are 16 DC outputs on the general connector. These outputs get their power internally from the MMC as shown in Figure 10.

**Figure 10: General Outputs Connected to Loads**

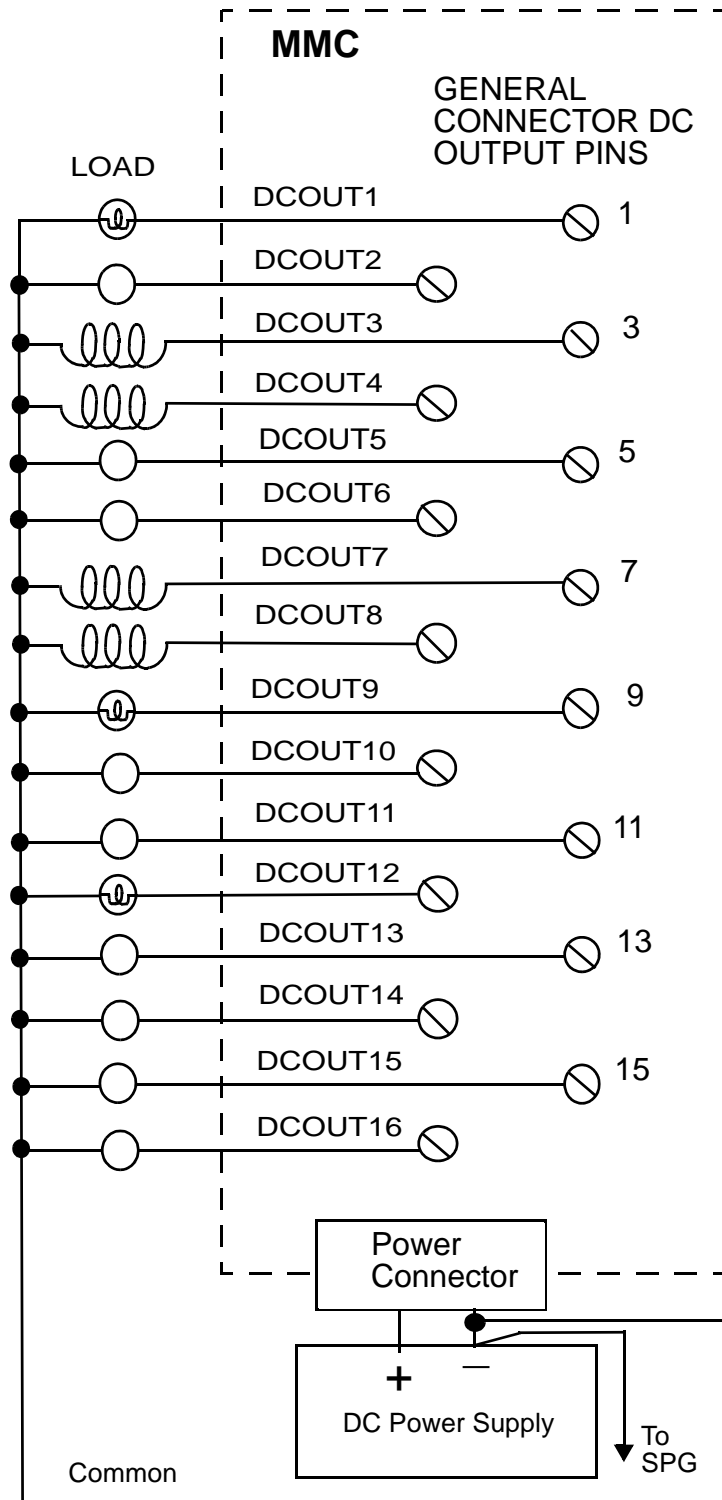

There are 16 general inputs on the general connector. The inputs are configured as two groups of eight. Each group can be configured as sourcing or sinking. Connect the DCSS pin to IO24C for a sourcing configuration. Connect the DCSS pin to +24V for a sinking configuration. You can use the internal +24 V supply as shown in Figure 11.

**Figure 11: Sink/Source General Input Configuration**

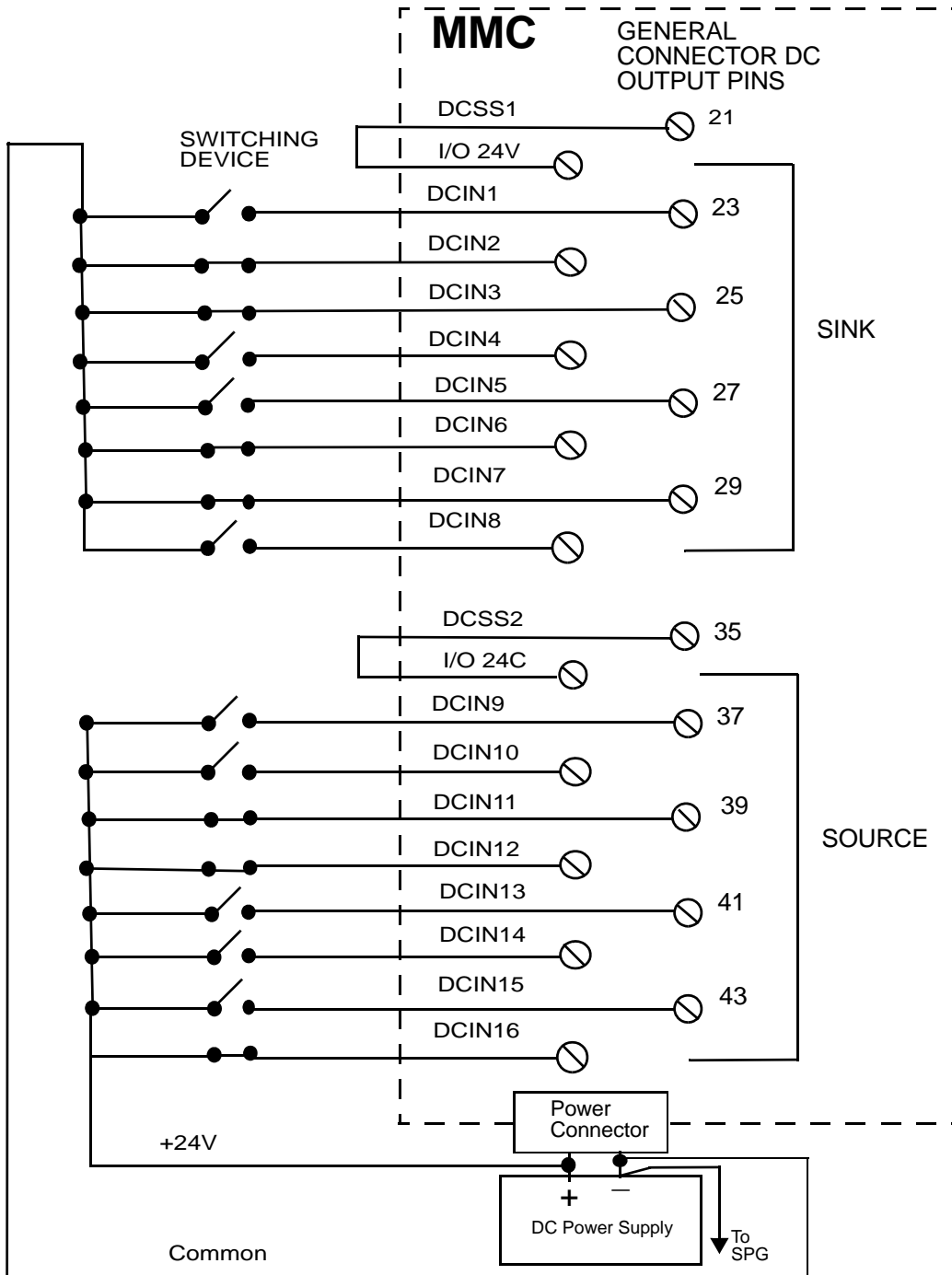



## 9.5 Power Connection

You must provide a +24 VDC power supply as the power source for the MMC. The power supply screw terminal connection (3 pin) is at the bottom of the CPU section of the MMC. This +24 V appears as an output at several points on the MMC connectors. Figure 12 illustrates the pin-out.

**Figure 12: Pin Out for the 3-pin Power Supply Screw Terminal Connection**

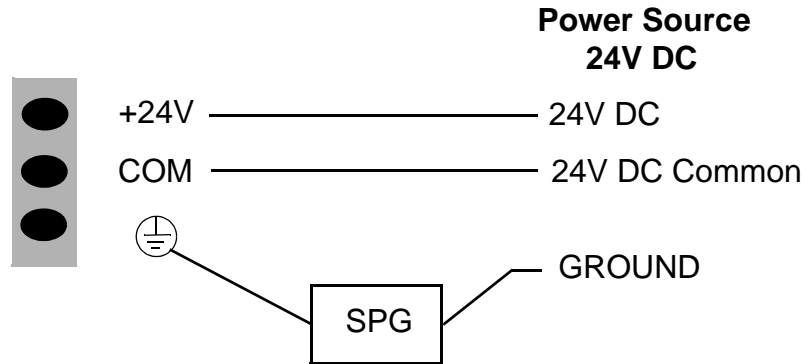

The 24 VDC applied at the MMC input power connector is also available:

- To power the DC outputs
- To power the sink/source inputs
- To power the axes interface
- To power the optional Ethernet or DeviceNet modules

**NOTES**

---

---

## 10 MMC Analog Servo Connections for Motion Control

---

### NOTE

The MMC-A2, MMC-A4, MMC-A2 Plus, and the MMC-A4 Plus already have either a 2 1/2 axis analog module or a 4 1/2 axis analog module integrated within the MMC cabinet. You can also add additional 4 1/2 axis analog modules (MMC-AIO Axis I/O option modules) to the MMC Plus modules. This section pertains to the integrated analog module as well as the optional analog modules.

There are four Axis connectors and one Auxiliary I/O connector on the MMC analog board.

### 10.1 Axis Connectors

Each axis has its own 15 pin high density D connector. Each axis connector provides the following signal connections:

- One 16-bit resolution analog output ( $\pm 10$  VDC)
- One quadrature, incremental encoder input
- Two DC outputs (24 VDC sink or source)
- One DC input (24 VDC sink or source)
- +24 VDC output

**Table 13: MMC to Drive Connections**

MMC Axis Signal	Connection
Analog output	Drive command
Encoder input	Drive encoder output
DC output 1	Drive enable input
DC output 2	Drive reset input
DC input 1	Drive fault output (Drive Ready)
DCOSS	+24V or COMMON (on MMC)

**Table 14: Pinouts for MMC Axis Connector**

Pin	Description	Pin	Description
1	A	9	DA-
2	A/	10	I/
3	B	11	+24 VDC out
4	B/	12	COM
5	I	13	DCOUT1
6	DCIN+	14	DCOUT2
7	DCIN-	15	DCOSS
8	DA+		

The metal shell of the 15-pin connector is tied to the chassis ground terminal on the MMC power connector. Cables provided by G&L Motion Control will have the shield connected to the metal shell of the cable connector. If you use other cables, be sure to connect the shield to the metal shell of the connector.

The DC outputs can be configured for either sink or source operation. When the DCOSS pin is tied to the +24V, the outputs will be in a source configuration as shown in Figure 13.

**Figure 13: Source Configuration**

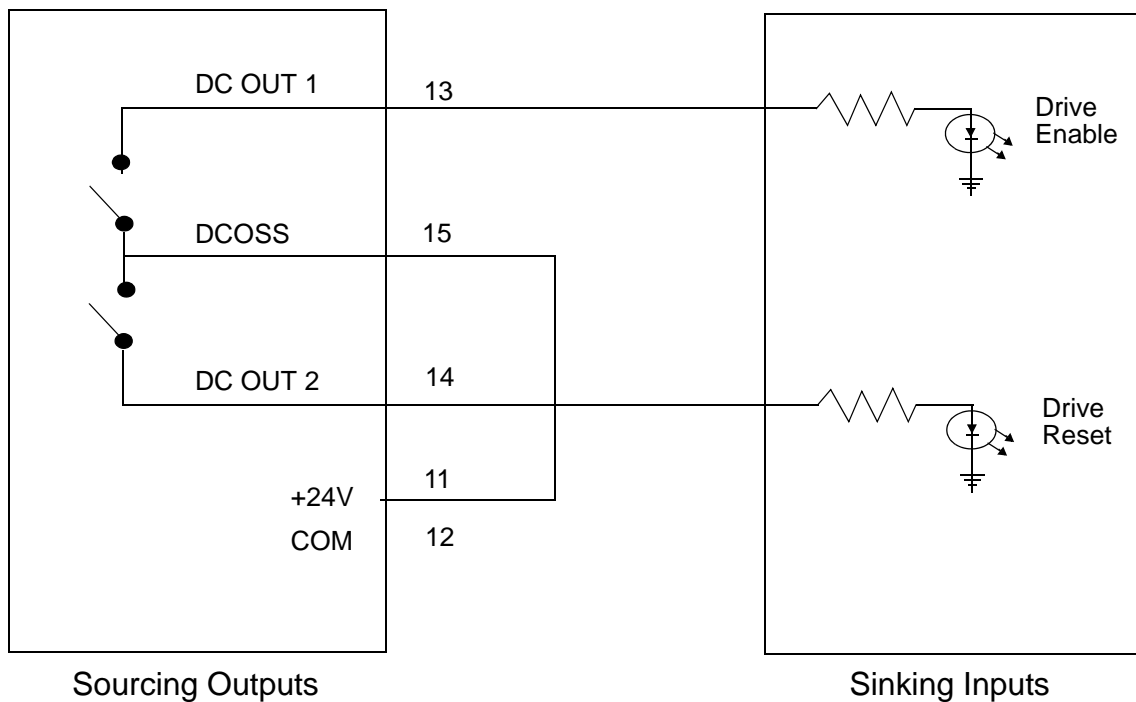

When the DCOSS pin is tied to COMMON, the outputs will be in a sink configuration as shown in Figure 14.

**Figure 14: Sink Configuration**

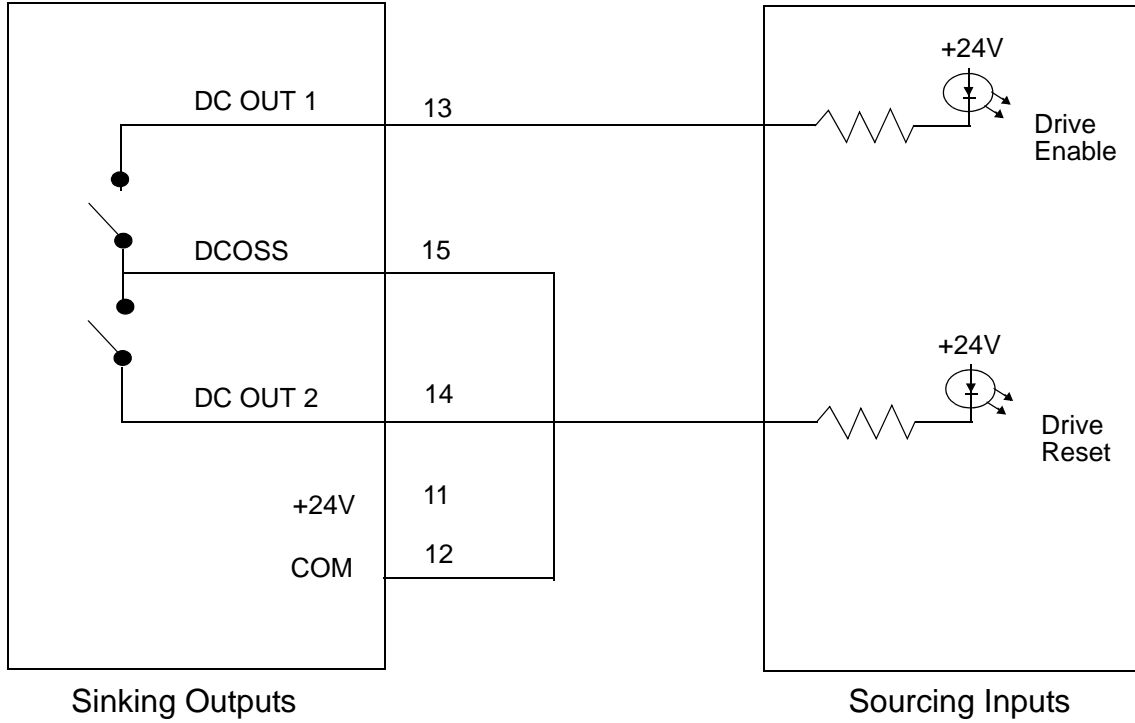

The analog output is connected to the drive command input. Only twisted pair wire should be used to make the connection between the analog output and the drive as shown in Figure 15.

**Figure 15: Axis Analog Output Connected to Drive Command Input**

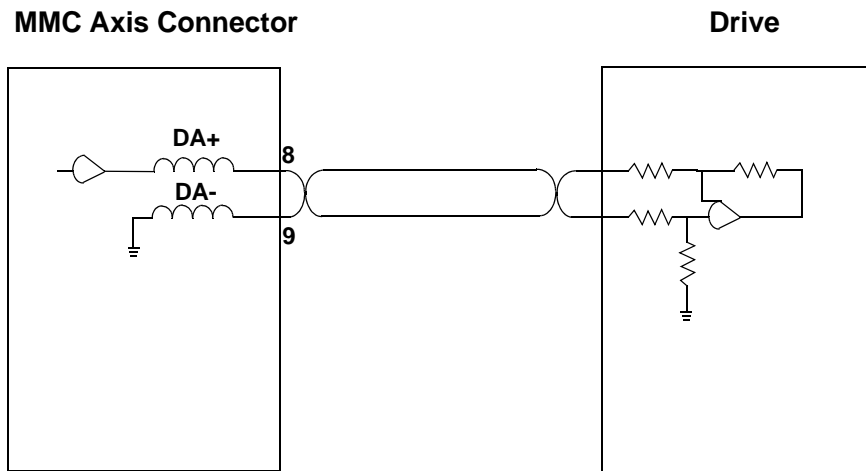

Drives will typically have an output signal indicating that the drive is operational. This "drive ready" signal can be connected to the Axis DC Input. One of the input pins should be connected to either +24 V or COM. The remaining input pin should be tied to the input signal that will be switching. Refer to Figure 16.

**Figure 16: Axis DC Input Connected to Drive Ready**

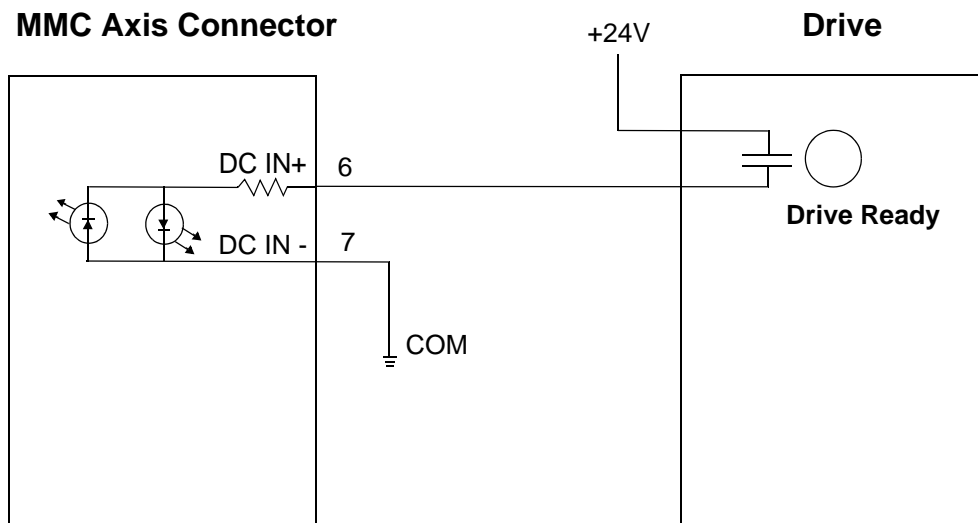

The encoder output signals from the drive should be connected to the encoder input on each axis. The MMC analog section accepts RS422 differential inputs. The encoder signals should be quadrature type. All encoder wiring between the MMC and the drive should be shielded twisted pair.

**NOTE**

The encoder input on the auxiliary connector is identical to the encoder inputs on the axis connectors. See Figure 17.

**NOTE**

The power supply that powers the encoder must be referenced to the power supply that powers the MMC. This is done by connecting the "common" terminal of each supply back to Single Point Ground. Failure to observe this precaution may result in sporadic encoder operation and/or damage to the MMC.

**Figure 17: MMC Encoder Inputs Connected to Drive Encoder Outputs**

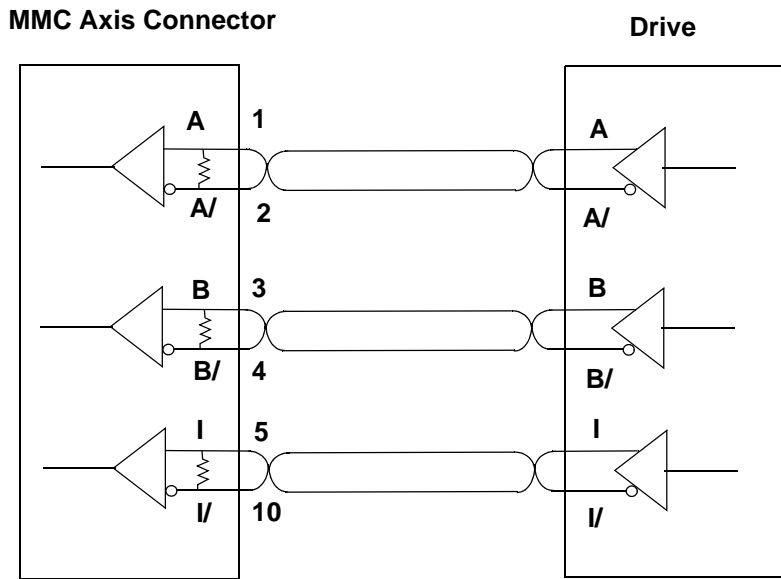



## 10.2 Auxiliary I/O Connector

The auxiliary I/O 44-pin connector provides the following inputs:

- One quadrature, incremental encoder channel (1 Mhz frequency, RS422 interface)
- Five fast DC inputs (one per encoder input) for high speed position latching)
- One 12-bit resolution analog input channel
- 12 optically isolated DC inputs
- +24 VDC output
- +5 VDC output
- Seven Shields

The auxiliary I/O connector pinout for the MMC-A4 (4 axes) is listed in Table 15.

**Table 15: Pinout for Auxiliary I/O Connector MMC-A4**

Pin	Description	Pin	Description	Pin	Description
1	A	16	FASTIN1+	31	DCSSA
2	A/	17	FASTIN1-	32	DCIN1
3	B	18	SHIELD	33	DCIN2
4	B/	19	FASTIN2+	34	DCIN3
5	I	20	FASTIN2-	35	DCIN4
6	I/	21	SHIELD	36	DCIN5
7	SHIELD	22	FASTIN3+	37	DCIN6
8	+24 VDC out	23	FASTIN3-	38	DCSSB
9	+24 VDC out	24	SHIELD	39	DCIN7
10	COM	25	FASTIN4+	40	DCIN8
11	COM	26	FASTIN4-	41	DCIN9
12	+5 VDC out	27	SHIELD	42	DCIN10
13	ANLGIN+	28	FASTIN5+	43	DCIN11
14	ANLGIN-	29	FASTIN5-	44	DCIN12
15	SHIELD	30	SHIELD		

The auxiliary I/O connector pinout for the MMC-A2 (2 axes) is listed below in Table 16.

**Table 16: Pinout for Auxiliary I/O Connector MMC-A2**

Pin	Description	Pin	Description	Pin	Description
1	A	16	FASTIN1+	31	DCSSA
2	A/	17	FASTIN1-	32	DCIN1
3	B	18	SHIELD	33	DCIN2
4	B/	19	FASTIN2+	34	DCIN3
5	I	20	FASTIN2-	35	DCIN4
6	I/	21	SHIELD	36	DCIN5
7	SHIELD	22	NC	37	DCIN6
8	+24 VDC out	23	NC	38	NC
9	+24 VDC out	24	SHIELD	39	NC
10	COM	25	NC	40	NC
11	COM	26	NC	41	NC
12	+5 VDC out	27	SHIELD	42	NC
13	ANLGIN+	28	FASTIN5+	43	NC
14	ANLGIN-	29	FASTIN5-	44	NC
15	SHIELD	30	SHIELD		

Each encoder channel has a fast DC input associated with it. The fast input can be used to latch the encoder position. Shielded twisted pair wiring should be used for all fast input connections. The fast inputs can be connected in either a source or sink configuration. The source configuration is illustrated in Figure 18.

**Figure 18: Fast Inputs Connected Using Shielded Twisted Pair (Source)**

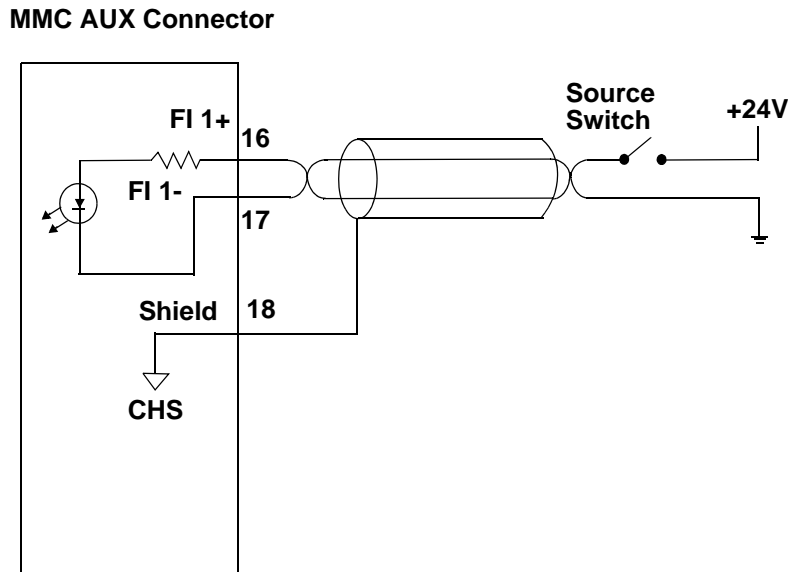

The fast input sink configuration is illustrated in Figure 19.

**Figure 19: Fast Inputs Connected Using Shielded Twisted Pair (Sink)**

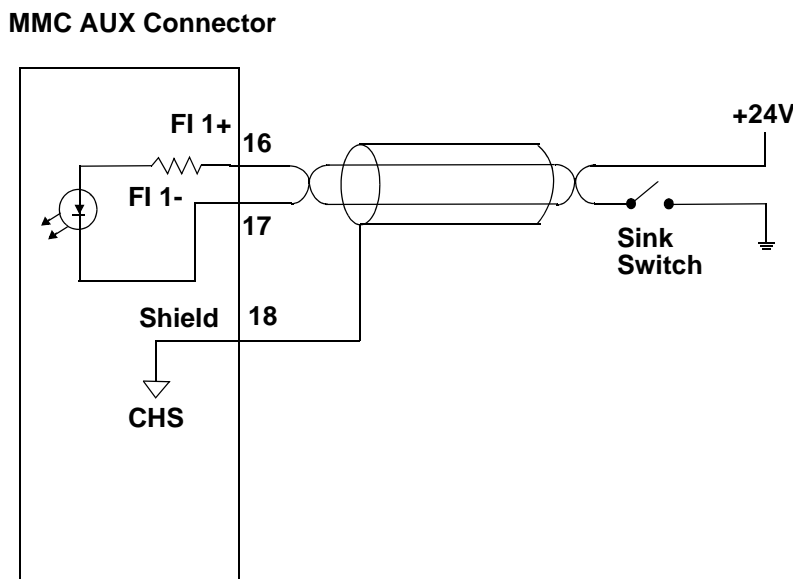

There are 12 general purpose inputs on the auxiliary connector. The inputs are configured as two groups of six. Each group can be configured as sourcing or sinking. Connect the DCSS pin to COM for a sourcing configuration. Connect the DCSS pin to +24V for a sinking configuration. You can use the internal +24 V supply as shown in Figure 20. The 12 inputs are available on the four axis MMC. The two axis MMC has six inputs. See the pinouts on Table 16 on page 50 for those connections.

**Figure 20: Sink/Source Connections using Internal +24 V Supply (4-Axis MMC)**

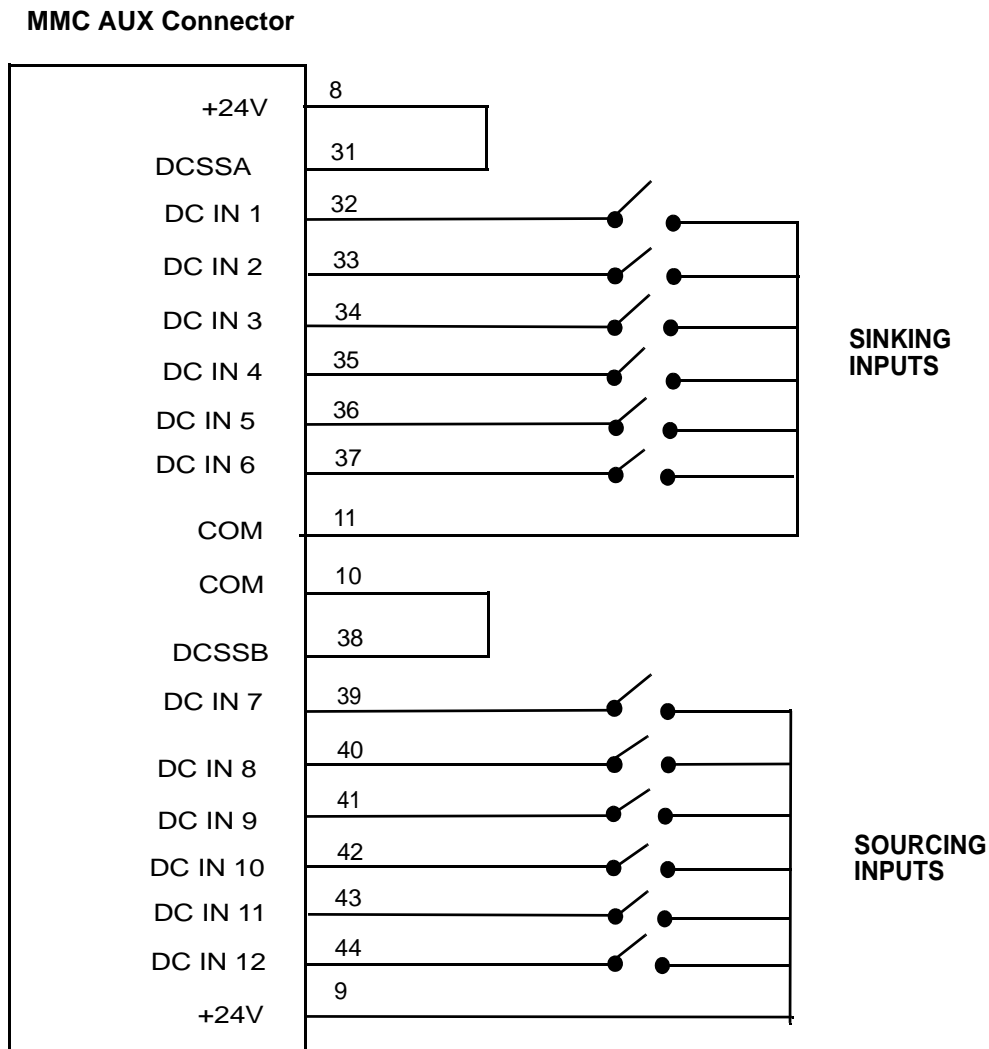

Or you can use an external +24 V supply as shown in Figure 21 on page 53.

Figure 21: Sink/Source Connections using External DC Supply(4-Axis MMC)

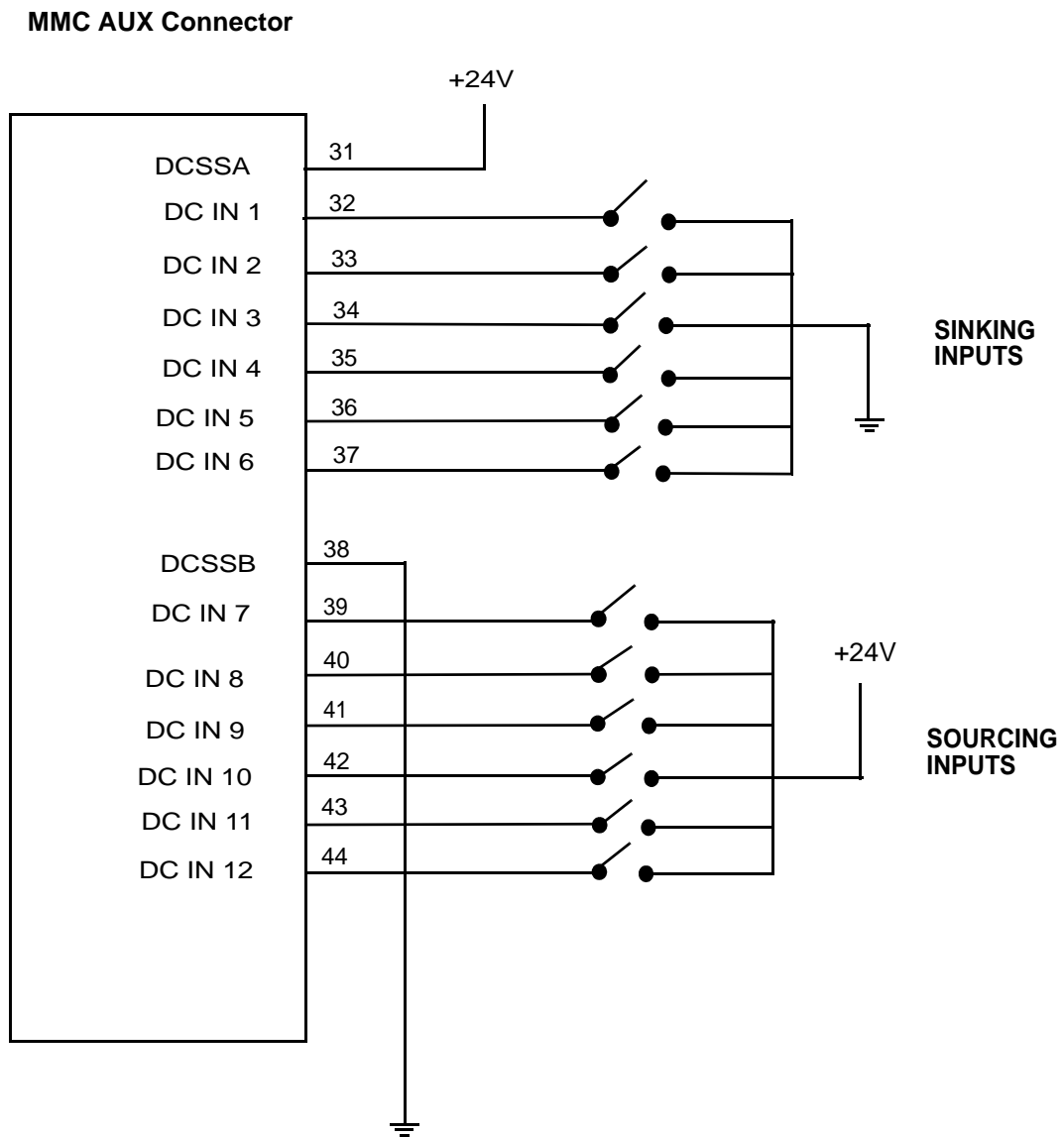

# 11 MMC SERCOS Connections for Motion Control

## 11.1 SERCOS Receive and Transmit Ports

The SERCOS port located in the center of the board can connect to one SERCOS ring. The connection to this ring is made through a pair of female fiber optic SMA connectors. The module's transmitter is connected to the first receiver in the loop and the module's receiver is connected to the last transmitter in the loop.

**Figure 22: SERCOS Connections - One Ring**

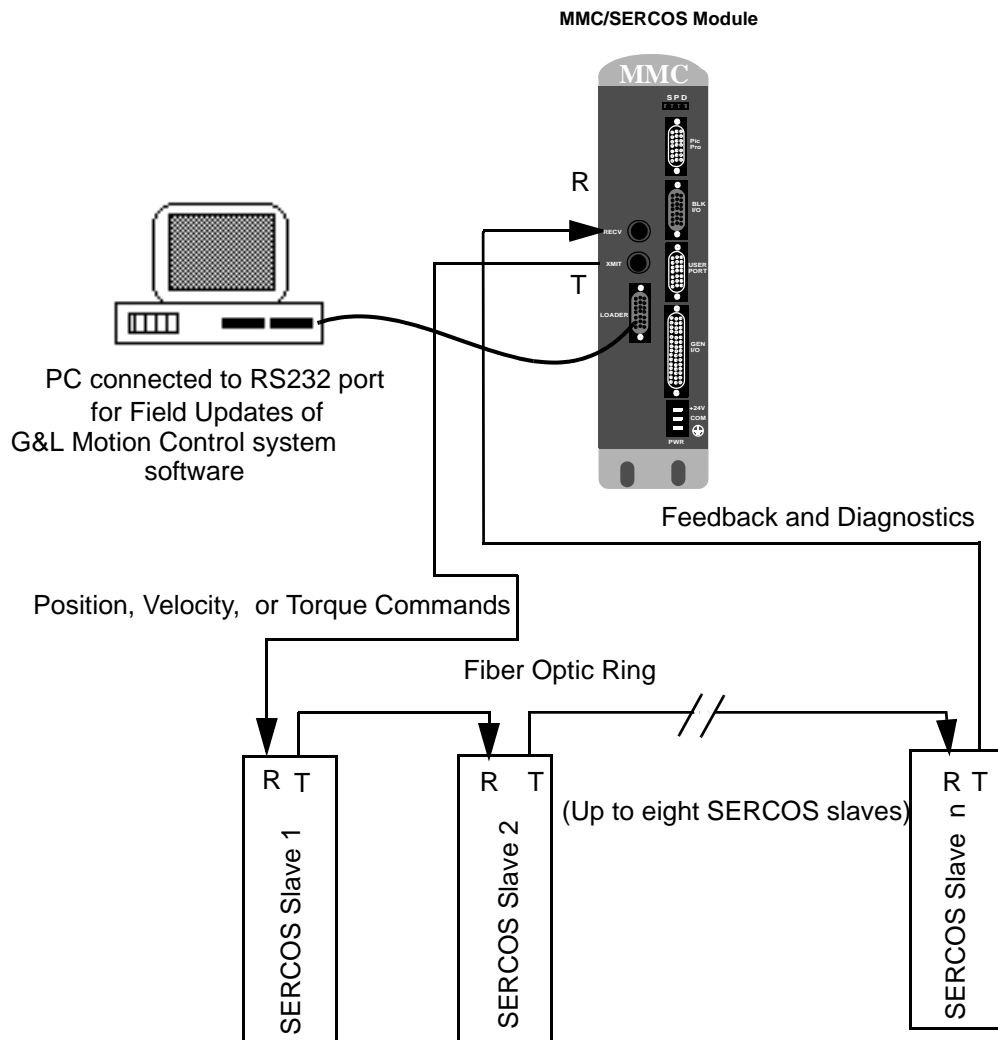

**Table 17: SERCOS Fiber Optic Cables**

<b>Description</b>	<b>Model Number</b>	<b>Length</b>	<b>Part Number</b>
Heavy Duty SERCOS Cable	SERCOS-0.50m-6mm-AA	.05 Meters (1.5')	M.1302.6379
	SERCOS-1.00m-6mm-AA	1 Meter (3.3')	M.1302.6400
	SERCOS-2.00m-6mm-AA	2 Meters (6.6')	M.1302.6401
	SERCOS-3.00m-6mm-AA	3 Meters (9.9')	M.1302.6402
	SERCOS-5.00m-6mm-AA	5 Meters (16.5')	M.1302.6403
	SERCOS-10.00m-6mm-AA	10 Meters (32.5')	M.1302.6404
	SERCOS-15.00m-6mm-AA	15 Meters ( )	M.1302.6405
	SERCOS-30.00m-6mm-AA	30 Meters ( )	M.1302.6406

## 11.2 Serial (Loader) Port

There is an RS232 serial port on the front of the module. This is used to connect to a PC in order to do a field update of the FLASH memory on the processor. The pinout is shown in Table 18.

**Table 18: Pinout for the 9-Pin D Connector**

<b>Pin #</b>	<b>Signal Name</b>	<b>In/Out</b>
2	Receive Data	In
3	Transmit Data	Out
5	Ground	In/Out

---

---

## 12 Basic MMC Theory of Operation

---

### 12.1 Machine Control Board Operation

Figure 23: MMC Machine Control Board External Components

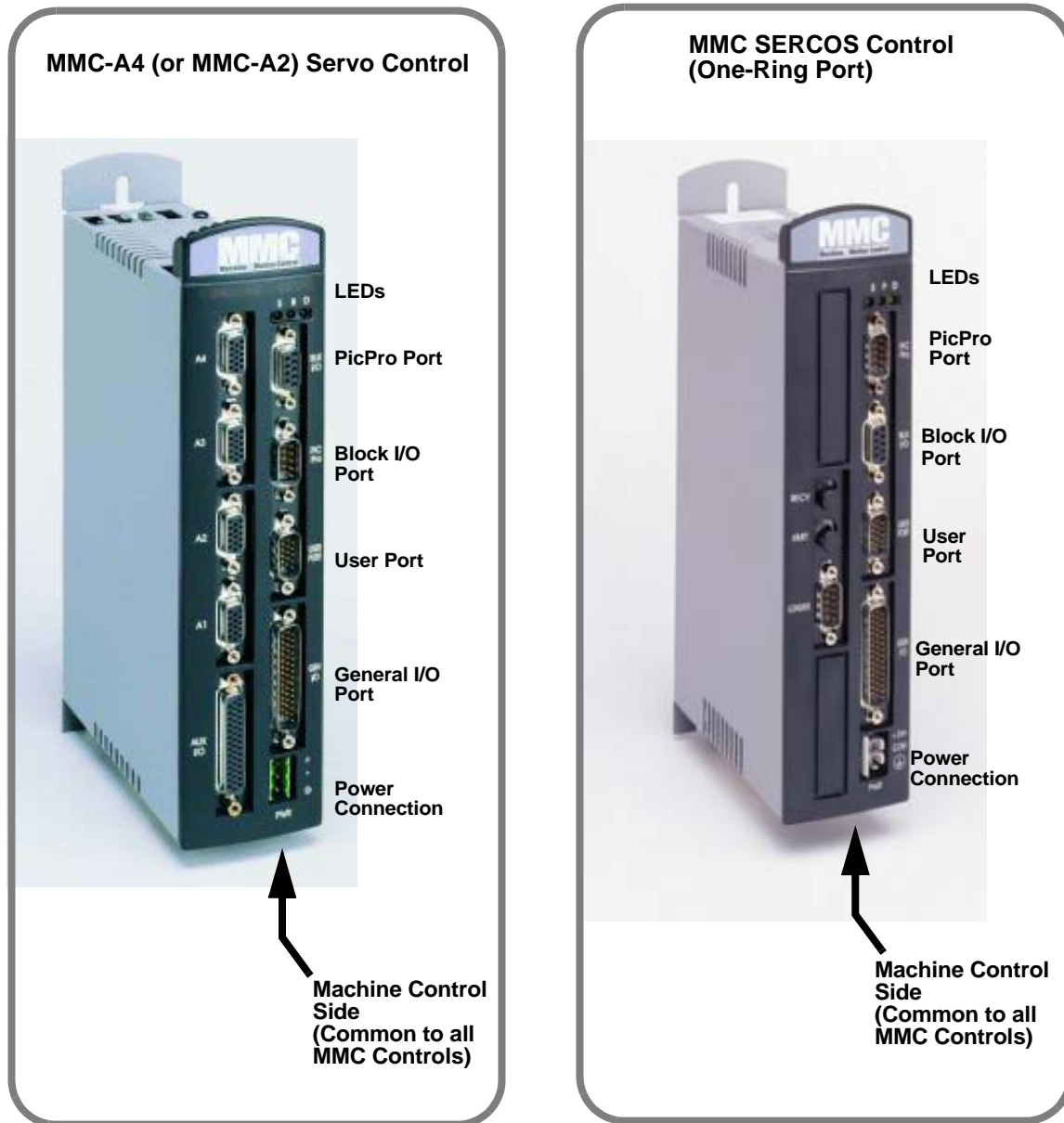



## 12.2 LEDs

There are three LEDs on the top of the CPU section of the MMC.

**Figure 24: LEDs**

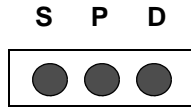

Below is a list of the LEDs and what they mean.

<b>Scan (S) Green</b>	
ON	The processor is executing the application program.
OFF	Scan is lost and there is an orderly shut down procedure followed.
<b>Power/Battery (P) Green</b>	
ON	Power is on to the system and the battery is OK. It indicates that the on-board +5 VDC supply is within tolerance.
OFF	Power is off.
<b>Flashing</b>	Power is on to the system (+5 V supply is OK) but the battery is bad. Replace lithium battery. See replacement procedure that follows.
<b>Diagnostic (D) Yellow</b>	
ON	On briefly during startup diagnostics. If it remains ON, module has failed startup diagnostics.
OFF	Normal operation
<b>Flashing</b>	Flashes error codes (listed below) under certain conditions.

## 12.3 Diagnostic Error Codes

While the MMC is running, the DIAG LED on the CPU module will flash a three digit code signal if there is an error. For example, if there is a long pause-flash-pause-flash-flash-pause-flash-flash-flash-long pause, the code is 123. The errors are described below.

Code	Error	Description
123	Scan too long	A ladder scan loss has occurred because the CPU takes more than 200 ms to scan the application program. Whenever the scan light is out, the discrete outputs go to the OFF state and the analog outputs are zeroed.
124	Excessive overhead	The system overhead update time is excessive.
125	Insufficient memory	There is insufficient memory on the CPU to run the current program.
126	No hardware bit memory	There is no bit memory installed on the CPU and the program requires it.
127	No software bit memory	There is no bit memory capability via software and the program requires it.
222	Driver error	No driver support on the CPU for the I/O module. Update your system EPROMs.
22_	Master rack error	The I/O modules in the master rack do not match what was declared in the hardware master declaration table. The number of flashes in the third digit ( ) identifies the slot number that is in error.
232	Communications error	A failure has occurred in remote I/O communications.
3_ _	Expansion rack error	The I/O modules in the block I/O modules do not match what was declared in the expansion hardware declaration table. <b>For block I/O modules:</b> The number of flashes in the second and third digits indicates the block I/O module (01 through 77). The second digit will flash a 1 - 7, 10 for 0. The third digit will flash a 1 - 9, 10 for 0. For example, if the second digit flashes <b>3</b> times and the third digit flashes <b>10</b> times, the module is <b>30</b> .

## 12.4 MMC Machine Control

The MMC converts input power into DC power at voltages of + 5V, + 15 V, and - 15 V and supplies them to the logic side of the system. The same supply that powers the MMC can be used for the fieldside of the system. Optionally, an external power supply (or supplies) can be used for the field side of the system. Such supplies are not routed through the MMC, but they should all have the same power cut-off switch as the MMC.

### CAUTION

Always shut off power at the main disconnect switch before you begin to work on the MMC.

The MMC does the following:

- Performs diagnostic tests.
- Checks the battery.
- Performs routine maintenance tasks.
- Executes the application program.
- Communicates with the I/O.
- Maintains communication with the workstation through the PiCPro port.
- Maintains communication with the user interface device through the user port. (Details for this communication depend partly on the type of interface device. Refer to the manual that comes with the device.)
- Provides block I/O capability.

## 12.5 Application in Flash

The MMC has a flash chip on board that allows you to load an application program into it. This is standard on the MMC. Having the application in the standard flash chip ensures that you will not lose the application if the battery fails. On power up, the application is transferred from the flash chip to RAM as it is when directly downloaded from PiCPro.

To place the application in flash:

1. Compile the application into a hex file in PiCPro.
2. Use the Download Hex command in PiCPro to download the application into flash.

Even though you have placed an application in flash, you can still download and run a different application from PiCPro. However, when you cycle power on the MMC, the application in flash will always be placed into RAM.

## 12.6 General I/O Output Operation

Each of the 16 outputs on the general I/O connector is a solid state switch rated at .250 A. It turns on or off according to the logic state sent to it by the CPU. If the CPU sends it a logic 1, the switch closes and the device is powered. If the CPU sends a logic 0, the switch opens and power to the device is cut off. The CPU updates the logic state for each switch every time it scans the program.

The logic side of the switch is optically isolated from the field side. If you need to know whether voltage is actually present at the field side, use a voltmeter.

There are two groups of eight outputs: group A = output 1 through output 8, group B = output 9 through output 16. Each group is capable of detecting a short circuit condition. When a short circuit condition is sensed, all outputs in the group are turned off and remain off for approximately 100 ms regardless of ladder activity. After 100 ms, the ladder again controls the outputs. In addition, each output is protected with internal clamping diodes. Without clamping, high voltage transients (kickback) from inductive loads might damage the module.

## 12.7 Protecting from an Inductive Load

Resistive and inductive loads can be connected to the MMC General outputs and controlled by the system with no precautions other than making sure they have a connection to the common of the DC power supply.

Inductive loads have an electrical "kickback" when current is stopped. This can damage or destroy the output switching device. Each output has a diode through which reverse current can be safely routed.

The internal diode works with an inductive load. When an output is energized, represented by a closed switch, current passes through the load into the common line. When the output is de-energized, represented by an open switch, current stops and the inductive field collapses. The state of the outputs is controlled by the CPU. This creates a reverse voltage across the load called "kickback" which tries to continue the current. The voltage is in series with the DC power supply. The combined voltage appears across the output switching device in the module.

If this were the only path available, voltage across the device would peak at several hundred volts. The internal diode provides another path for current. This limits the peak reverse voltage across the load to less than 1 V. Every switch has this protection so an inductive load can be connected to any point.

**Figure 25: Diagram of Internal Protection for Inductive Loads**

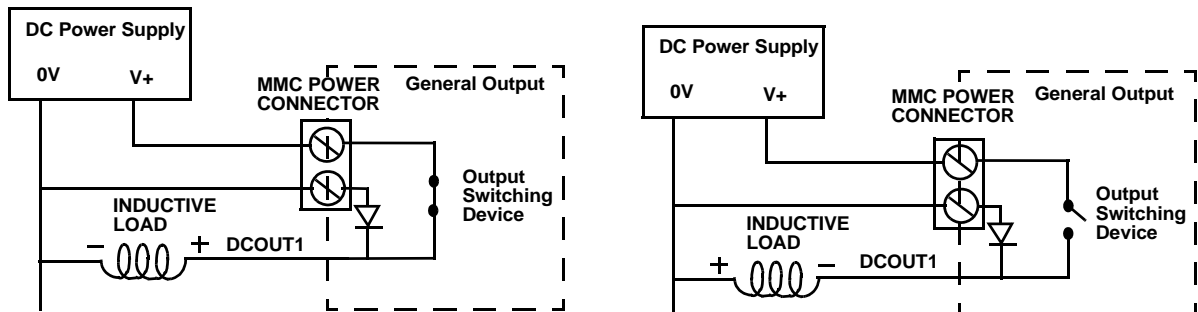

a) Output Energized

b) Output De-energized

## **12.8 DC Output Theory of Operation (Axis Connector)**

Each axis output (either on the base MMC or on the MMC-Axis I/O Option Module) is an optically isolated solid state switch. It turns on or off according to the logic state sent to it by the CPU. When the switch turns on, current flows through the switch. When the switch turns off, current flow stops.

These outputs are intended to interface with the drive enable and drive reset inputs. When an output is turned on current can flow through the switch in either direction. This allows the outputs to be connected in a sink or source configuration.

For safety reasons, all outputs turn off (no current flow) when a scan loss condition occurs.

## 12.9 DC Input Operation (Axis, AUX, General Connectors)

Each input is guaranteed "on" at 14 to 30 VDC and guaranteed "off" at 0 to 5 VDC; polarity doesn't matter. Its on/off state is converted to a corresponding logic 1 or 0. This logic state is transmitted through the system bus to the CPU module, where the processor uses it as data in the ladder program. The logic side of the input is optically isolated from the field side.

The shaded blocks in Figure 26 below show the limits specified by the IEC. The lines show the maximum and minimum V/I of the inputs in this module. The voltage/current curve in this graph shows that the input module is well within the IEC Type 1 limits.

Figure 26: Input Characteristics Compared to IEC Standards

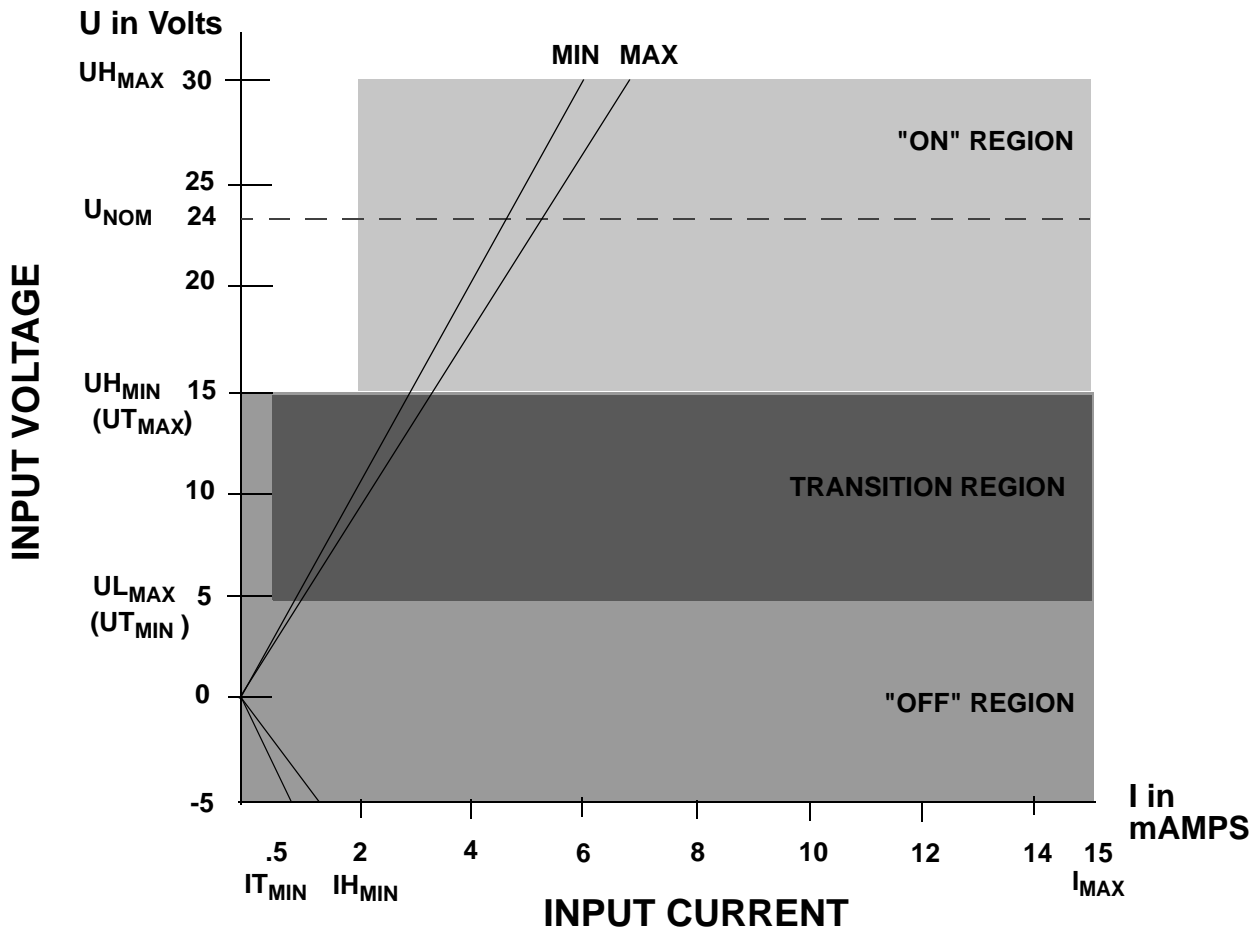

**IMPORTANT**

Switching devices can sometimes have a leakage current that exceeds the  $I_{T_{min}}$  (current allowed when off) of an input module. In order to use such a device, an impedance (typically, a resistor) needs to be used in parallel with the input.

For example, some of the newer proximity switches use two wires instead of three. The third wire was used for a power or ground line. Without the third wire, the switch is easier to install. However, it requires more leakage current in the off state to power its internal circuitry.

As a conservative estimate, use the following formula to calculate an external resistance value. It keeps the input voltage at or below 2.4V when the switching device is in the "off" state.

$$\frac{2.4V}{\text{Switch Leakage} - 0.75mA} \geq R$$

If the switch leakage specification is  $\leq 1.7$  mA, then:

$$\frac{2.4V}{1.7 - 0.75mA} \geq 2.5K\Omega$$

Use a resistor less than or equal to 2.5 K $\Omega$ . Be sure that the wattage is adequate for the resistor when the switching device is in the "on" state remembering that:

$$P = \frac{V_{ON}^2}{R}$$



---

---

## 13 Analog Servo Control Operation

---

Figure 27: Locations of Input, Output, Encoder Pins on the MMC-A4 Unit

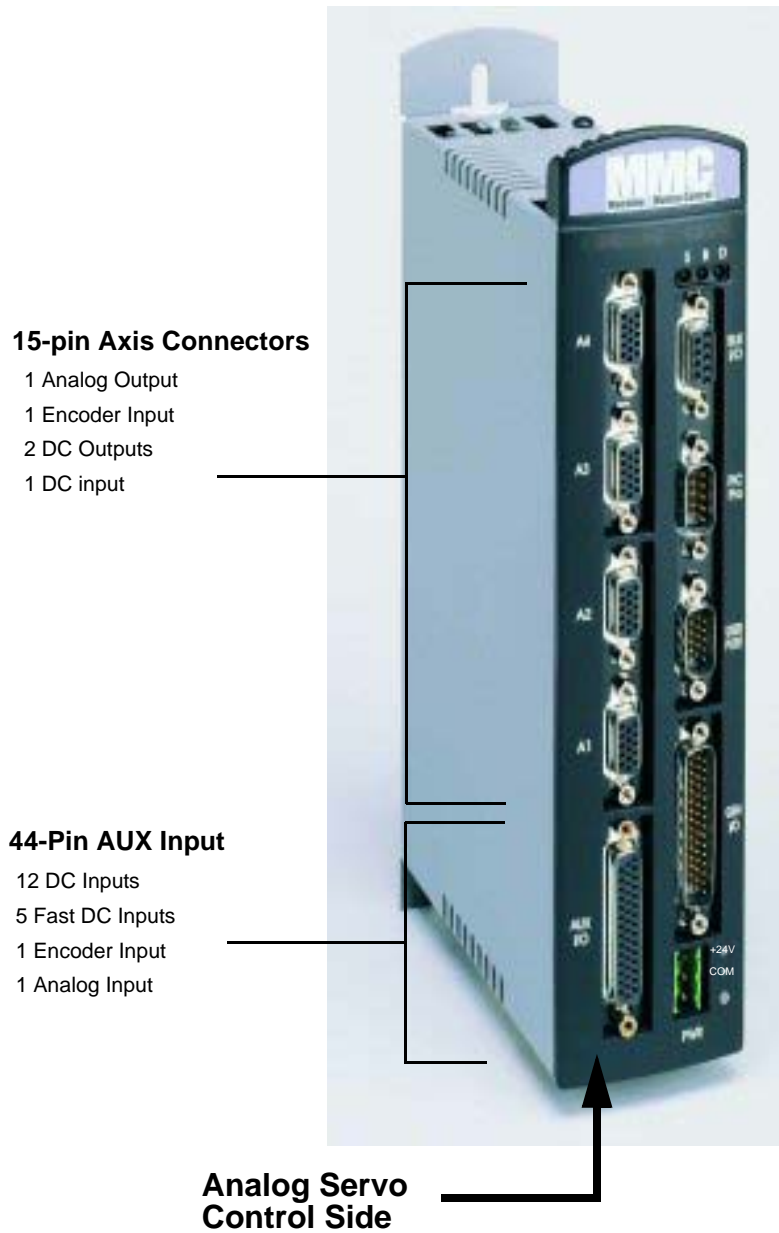

## 13.1 Analog Output Theory of Operation (Axis Connectors)

The CPU sends the analog output section a 16-bit digital word for each analog output channel used. Each digital word is converted to a corresponding voltage within the range of  $\pm 10$  V. The voltage is buffered and brought out to a pair of I/O connections as a differential type voltage output. This output is less subject to interference from electrical noise than a single-ended output would be.

You can adjust each analog output channel in software for offset adjustments, gain scaling, and unipolar outputs.

For safety reasons, all outputs are automatically reset to 0 V when a scan loss condition occurs.

## 13.2 Encoder Theory of Operation (Axis and AUX Connectors)

The encoder section uses differential type inputs to interface with up to five independent incremental encoders. These inputs accept RS422 level quadrature signals.

A *quadrature encoder* sends square wave type signals. When the shaft rotates at a constant velocity, the A and B outputs are square waves and are at the same frequency. However they are out of phase with each other by  $90^\circ$ . When the encoder shaft rotates in one direction, each A pulse leads the corresponding B pulse by  $90^\circ$ . When it rotates the other direction each A pulse lags its B pulse by  $90^\circ$ .

The signals illustrated in Figure 28 below indicate that the encoder shaft rotates in one direction at first. Its speed of rotation decreases to 0 and then it starts rotating the other direction. The signals are shown as differential.  $\bar{A}$  is the inverse of the signal A and  $\bar{B}$  is the inverse of signal B.

**Figure 28: Signals Transmitted by a Quadrature Encoder with Differential Outputs**

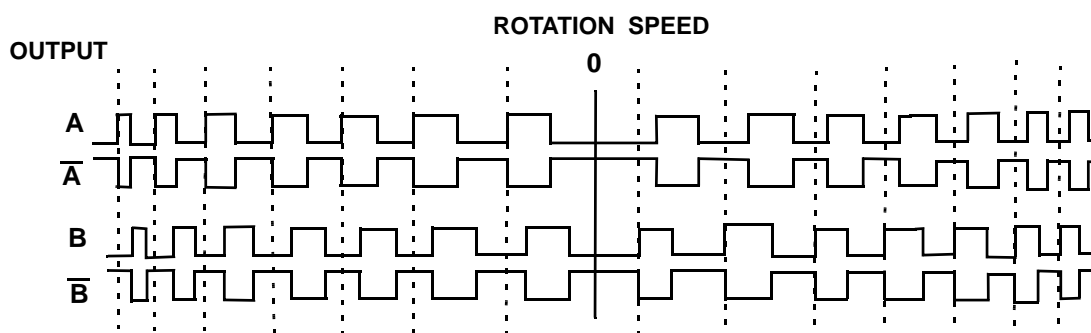

The maximum input frequency is 250,000 lines per second, which results in 1,000,000 Feedback Units (FUs) per second.

**Figure 29: Counting Quadrature Pulses**

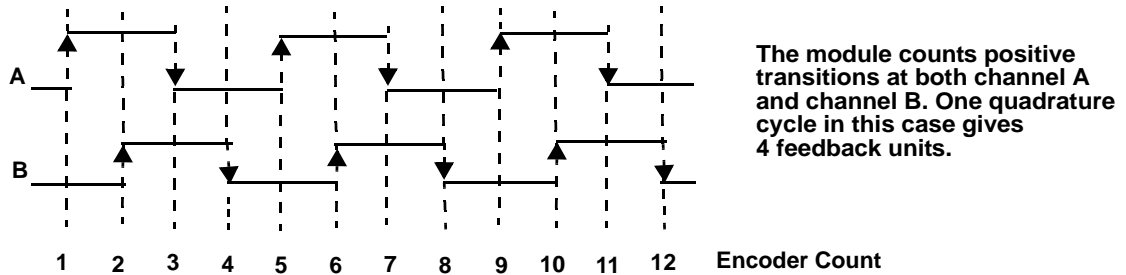

There is a 24-bit up/down counter for each channel. It is incremented or decremented on each A, B edge. There is also a 24-bit latch associated with each encoder channel.

The module can be programmed so that the counter value is "latched" or stored under one of these conditions:

- an index pulse from the encoder
- a positive or negative transition of the fast input
- the next index pulse after the required transition of the fast input

Each of the five 24-bit latches has a *fast 24 VDC input* associated with it. Each input is optically isolated. This input is intended to receive a signal from a device other than an encoder. It is typically used for referencing or synchronization purposes.

Fast input characteristics include:

- the detection of a signal occurs faster than it does for the DC inputs in other modules, due to less filtering. Because of this there is also less noise immunity.
- the response to a fast input signal is independent of ladder scan time. The module can be programmed to latch a position count as soon as this input is detected.

### **13.3 Analog Input Operation (AUX Connector)**

There is one differential analog input channel on this module. The input range is  $\pm 10$  VDC. The analog input voltage is sampled every 100  $\mu$ sec by a 12-bit A/D converter. The most recent conversion result is stored in an on-board register. This register can be read at any time by the CPU.

The analog input signal passes through a common mode and differential mode filter prior to being applied to the A/D converter. These filters improve the noise immunity of the module.

---

---

## 14 MMC SERCOS Control Operation

---

The MMC SERCOS board is an alternate type of motion control used as part of an MMC base unit. It provides an interface between the MMC and a fiber optic ring. A ring can have from one to eight SERCOS slaves. The module contains an on board processor. There is one SERCOS ring port located at the center of the module. This ring port has a receive and a transmit fiber optic connector. There is also an RS232 port used for loading FLASH memory updates.

The SERCOS board is controlled by an LDO created in PiCPro. An on-board processor interprets the functions and performs appropriate operations according to the SERCOS communications protocol.

The data transfer rate is 4M Baud with user-defined update rate.

If a scan loss occurs, SERCOS communications are reset. There is no communication with the SERCOS slaves until you reinitialize.

**Figure 30: Location of the SERCOS Ring Port on the MMC SERCOS Control**

**MMC SERCOS Control  
(One-Ring Port)**



**NOTES**

---

---

## 15 Replacing the MMC Battery

---

Follow the procedure below to replace the MMC battery when the "P" LED is flashing.

1. After DC power has been applied to the MMC for at least five minutes, turn off power. This ensures that the contents of memory will not be lost while the battery is removed. Disconnect the input power connector from the MMC.
2. Remove the MMC (including any optional modules) from the cabinet.
3. Use a static-free work surface if possible. Ground yourself using a properly grounded wrist strap before you open the case. These are standard precautions before handling any electronics component.
4. Lay the MMC system on the work surface. If there are no optional modules attached, remove the cover by removing the five screws, two on top, two on the bottom, and one on the right side of the MMC.  
If there are one or more optional modules attached, remove the four screws that attach the first optional module and remove the MMC from the optional modules.

<b>WARNING</b>
DO NOT touch any of the capacitors. Do not touch the pins on any of the ICs; even with precautions against static you may destroy the circuitry.

5. Refer to Figure 31 on page 73 for the location of the battery. Note how the polarity markers are oriented.



**Figure 31: Battery Location in MMC**

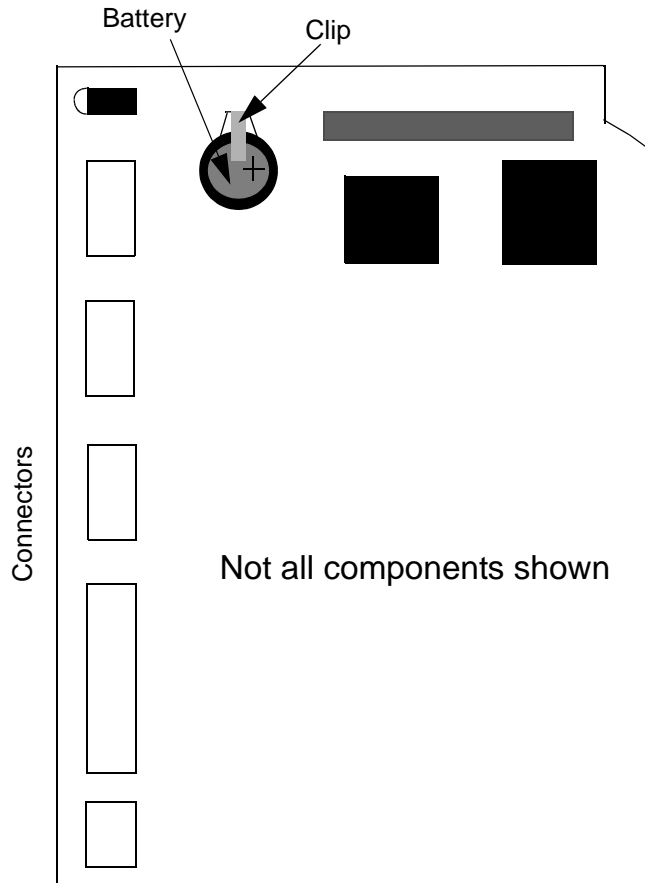

6. Use a screwdriver to gently pry up the battery clip. Slide the battery out. Replace it with a 3V coin cell, BR2032 battery, + side up.
7. Screw the cover or optional modules back on. Return the MMC to the cabinet. Connect the power cable. Turn on power and check the LEDs.

## 16 Specifications

General											
Characteristic		MMC Specifications									
						Number of servo axes available at six update rates*					
Model	Part Number	Speed	App Mem	RAM Mem	User Mem	8 ms	4 ms	2 ms	1 ms	.5 ms	.25 ms
MMC-A2	M.1017.3772	Std.	256K	128K	64K	2	2	2	2	2	1
MMC-A2 Plus	M.1302.7095	X3	256K	128K	64K	18	18	16	8	3	1
MMC-A4	M.1017.3774	Std.	256K	128K	64K	4	4	4	4	2	1
MMC-A4 Plus	M.1302.7096	X3	256K	128K	64K	20	20	16	8	3	1
MMC-S8	M.1017.3770	Std.	256K	128K	64k	8	8	8	4		

\* Using features such as servo tasks, S-curve, RATIO\_RL, M\_LINCIR, M\_SCRVLC, PLS, and CAM\_OUT places a heavier burden on available CPU time. Consult G&L Motion Control for assistance if you want to exceed the number of axes in this chart.

CPU	32 bit RISC processor with numeric coprocessor
Battery	3V Coin Cell, BR2032 lithium battery
<p><b>CAUTION for Lithium Batteries</b>            Danger of explosion if battery is incorrectly replaced. Replace only with the same or equivalent type recommended by the manufacturer. Dispose of used batteries according to the manufacturer's instructions.</p>	
Flash Disk	2 Megabytes
Memory	1 Megabyte max.
PiCPro Port (to workstation)	RS232 serial port, secured protocol Software selectable baud rate to 57.6K
User Port (to serial interface device)	RS232/RS485 serial port Supports RTS/CTS hardware handshaking Software selectable baud rate to 19.2K
Input voltage	20 VDC to 30 VDC

## Specifications

Input power	MMC: 250 mA plus I/O power MMC Plus: 450mA plus I/O power
Time-of-day clock Clock tolerance	Access via PiCPro 10.2 and above or your application program At 25°C (77°F), ±1 second per day Over temperature, voltage and aging variation, +2/-12 seconds per day
Operating temperature range	5°C to 55°C (41°F to 131°F)
Storage temperature range	-40°C to 85°C (-40°F to 185°F)
Humidity	5 to 95%, non-condensing
CE Marked	Conforms to Directives 73/23/EEC, 89/336/EEC, 92/31/EEC, 93/68/EEC by conforming to the following standards: EN 50081-2:1993EMC Generic Industrial Emissions EN 50082-2:1995EMC Generic Industrial Immunity EN 61131-2:1994/A11:1996 Low voltage directive requirements for programmable controllers Operates with emissions below EN55011/ CISPR 11 Class A limits Immune to: •Electrostatic discharge (4K V contact mode, 8K V air discharge) per EN61000-4-2 •RF electromagnetic fields per EN61000-4-3, ENV 50141, and ENV50204 •Electrical fast transients per EN61000-4-4 •Magnetic fields per EN61000-4-8 Refer to the EMC Guidelines for more information.
UL and C/UL Listed	E126417
Physical size	2.25" wide x 9.6" high x 5.3" deep 57.15 mm x 243.84 mm x 134.62 mm
Vibration (per IEC 68-2-6)	10-57 Hz (constant amplitude .15 mm) 57 - 2000 Hz (acceleration 2 g)
Shock (per IEC 68-2-27)	Four shocks per axis (15g/11 msec)

## Specifications

<b>Analog Output</b>	
Output channels	2 or 4
Resolution	16 bits
Output voltage range	$\pm 10$ VDC
Maximum output current (1K $\Omega$ load)	$\pm 10$ mA
Power on output voltage	0 V $\pm 100$ mV
Scan loss output voltage	0V $\pm 100$ mV
Accuracy	$\pm 0.375\%$ of FSR Drift $\pm 50$ ppm/ $^{\circ}$ C
Update rate	68 $\mu$ sec
<b>Analog Input</b>	
Input channel	1
Resolution	12 bits
Input voltage range	$\pm 10$ V
Accuracy	$\pm 0.2\%$ of FSR
Sample rate	100 $\mu$ sec
Common mode filter	3 dB @ 10 K Hz
Differential mode filter	3 dB @ 475 Hz

<b>Encoder Input</b>	
Input channels	3 or 5
Input receiver	2632 differential RS422 receiver
Encoder signals	Differential quadrature
Input threshold	$\pm 750$ mV
Input termination	120 ohm, provided on board
Maximum input voltage	5 V
Maximum A or B input frequency	250 K Hz (1 M feedback unit count rate)
Fast input voltage	Nominal 24 VDC, maximum 30 VDC
Guaranteed on voltage	15 VDC
Guaranteed off voltage	5 VDC
Turn on/off time	1 ms
<b>General, Auxiliary and Axis DC Inputs</b>	
Configuration	The general inputs are divided into two groups of eight. Each group can be configured for sourcing or sinking. The auxiliary inputs are divided into two groups of six inputs. Each group can be configured for sourcing or sinking. The axis inputs have one input per axis. Each input can be configured for sourcing or sinking. Operates with IEC Type 1 inputs (per IEC 1131=2).
Input voltage	Nominal 24 VDC, maximum 30 VDC
Guaranteed on voltage	15 VDC
Guaranteed off voltage	5 VDC
Turn on/off time	1 ms
Fast inputs	50 $\mu$ sec

<b>General DC Outputs</b>	
Number of outputs	16 outputs
Input voltage	Nominal 24 VDC, 30 VDC maximum
Configuration	Two groups of eight solid-state switches.
Protection of logic circuits	Optical isolation between the logic and field side, transient suppression on the 24V external supply
Maximum current	.25 A per output
Voltage range	24 VDC nominal, 5 to 30 VDC
Switch characteristics	Solid-state switches
Time delay on for resistive loads	50 $\mu$ sec max
Time delay off for resistive loads	50 $\mu$ sec max
Leakage current in off state	0.5 mA max
Switch voltage, maximum ON	1 VDC max
Short circuit protection for each group	15 A (max) pulses for about 130 $\mu$ sec every 100 msec until short is removed
Scan loss response	Outputs turn off
<b>Axis DC Outputs</b>	
Number of outputs	2 outputs per axis
Configuration	Each set of axis outputs can be configured as sourcing or sinking.
Maximum current	100 mA per output
Voltage range	24 VDC nominal, 5 to 30 VDC range
Scan loss response	Outputs turn off
<b>Auxiliary DC Output</b>	
+5 VDC	150 mA maximum current available. Connections to this point should be over short distances and away from electric noise signals.

<b>SERCOS</b>	
SERCOS Interface	Interfaces with one ring with from one to eight digital drives
SERCOS port	SMA female connectors for interfacing to 1000 $\mu$ meter plastic fiber optic cable with SMA male connectors. Fiber optic receiver specifications: Peak input power (optical level low) -31.2dBm max Peak input power (optical level high) -20.0 dBm min, 0.0dBm max Fiber optic transmitter specifications: Peak output power (optical level high) -10.5 dBm min, -5.5 dBm max
Update loader port	RS232 interface
Type	Plastic with step index profile (POF)
Core diameter Fiber diameter	980 $\mu$ m $\pm$ 60 $\mu$ m 1000 $\mu$ m $\pm$ 60 $\mu$ m
Operating temperature	0° C to 55° C (32° F to 131° F)
Minimum bend radius	One time: 30 mm Continuous: 80 mm
Tensile strength	One time: 250 N Continuous: 100 N
Connectors	SMA style male

*Specifications*



## 17 MMC Ethernet™ TCP/IP Module

### 17.1 Introduction

The ETHERNET - TCP/IP module provides the MMC with Ethernet access and Internet connectivity. A 10Base T connection is provided following the IEEE 802.3 specification. The data transfer rate is 10 Mbps. Applications can range from connecting several MMCs, connecting groups of MMCs and PCs, or connecting to a system that includes Internet access.

At the end of this document is a partial list of Internet links to useful information about Ethernet and TCP/IP networking.

The Remote Programmer Access switch (future feature) will allow you to enable/disable MMCPPro running over Ethernet. The DIAG LED goes on briefly while the diagnostic tests are running shortly after power is applied.

**Figure 17-1: MMC Ethernet - TCP/IP Module**

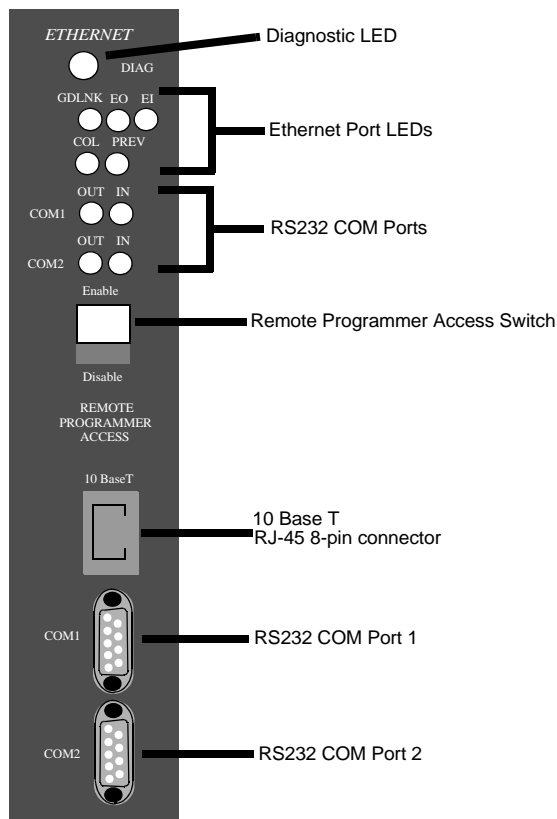

## 17.2 Connections

The MMCPPro cable is used to make a connection between the PC and the MMC.

1. Connect the PC to the RS232 Com 2 Port on the Ethernet - TCP/IP module to download the TCP/IP configuration file.
2. Connect the PC to the PiCPro Port on the CPU to download the application LDO.

Figure 17-2: MMC/PC Connections

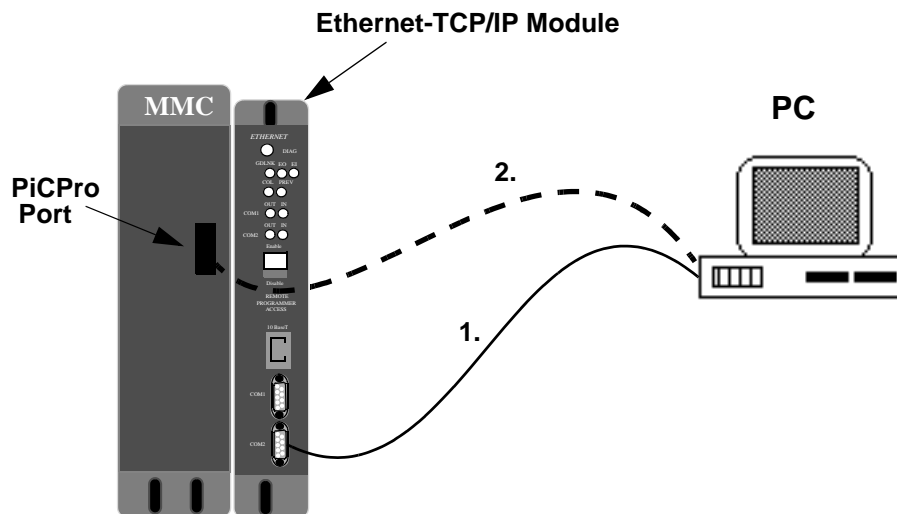

Use 10Base T (10 Mbps, baseband, over twisted pair cable) to set up your Ethernet - TCP/IP system. The table below summarizes the specifications (IEEE 802.3) for the Ethernet connection available on the MMC Ethernet - TCP/IP module.

	Connections
	10Base T
Type of Cable	Category 3 or 5 (5 recommended) UTP (unshielded twisted-pair) Shielded category 5 cable is optional.
Connection	RJ-45
Topology	Star
Distance	100 m (328') between transceiver (TCP/IP module) and hub
Maximum cable segment length	100 m (328')
Data Rate	10 Mbps

A typical MMC 10Base T connection is shown below.

**Figure 17-3: Ethernet - TCP/IP 10Base T Connections**

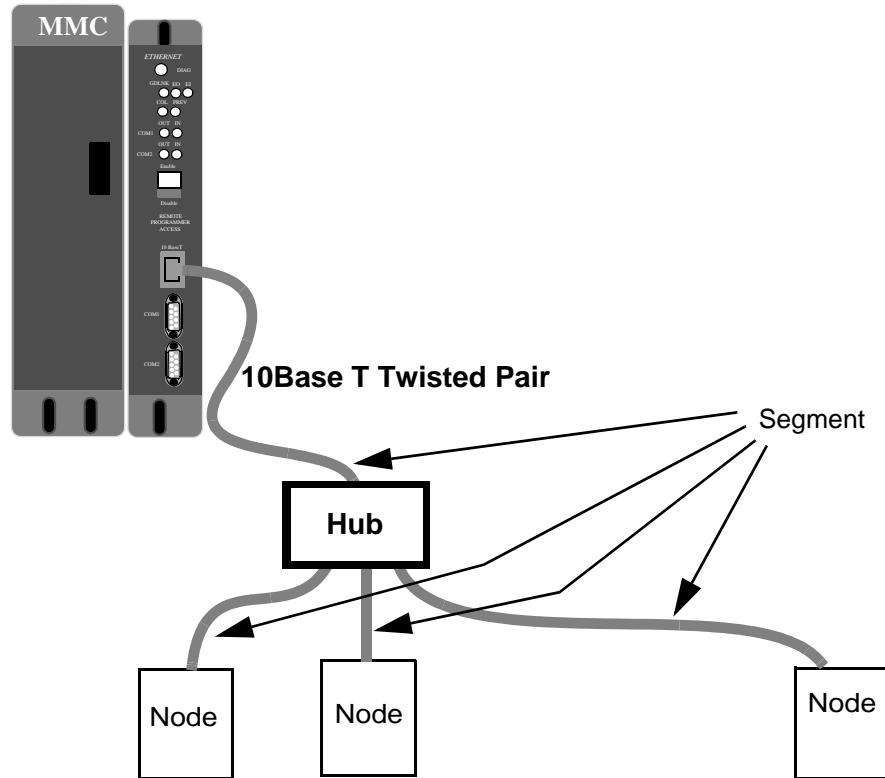

Maximum segment length is 100 m (328').

## 17.2.1 The Ethernet Port

The 10Base-T port uses a RJ-45 style 8-pin connector using 100 3/4 unshielded twisted pair category 3 or 5 cable (IEEE 802.3 section 14.4). The maximum length of the twisted pair cable segment is 100 m (328 ft.). NOTE: The connector is also suitable for shielded cable and will ground the shield to the chassis.

## 17.2.2 The RS232 COMM Ports

There are two RS232 ports at the top of the module as shown in Figure 4-3. COMM 1 will be used for modem connections (future). COMM 2 is used to download your configuration file to the MMC.

Pin #	Signal Name	
2	Receive Data	RX
3	Transmit Data	TX
5	Ground	Gnd
7	Ready to send	RTS
8	Clear to send	CTS
Shell	Chasis gnd	

## 17.3 LEDs

There are nine LEDs on the MMC Ethernet - TCP/IP module in addition to the DIAG LED. They are located directly under the DIAG LED as shown below.

**Figure 17-4: Ethernet - TCP/IP LEDs**

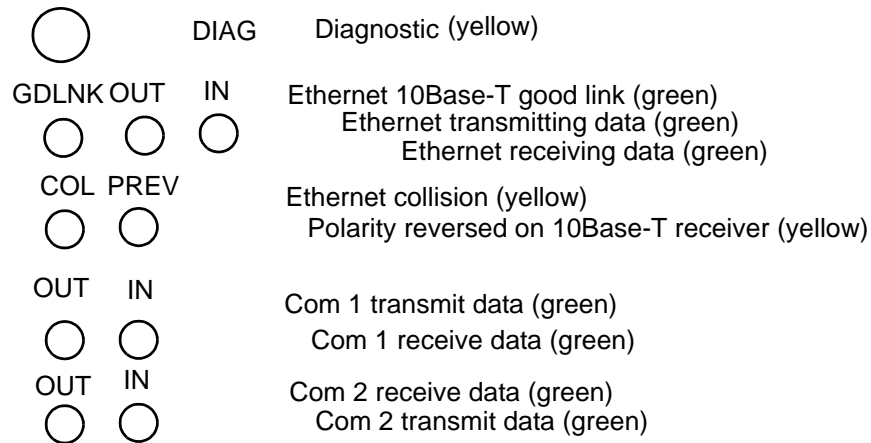

## 17.4 Firmware Update

For this release, the firmware required for using the MMC Ethernet-TCP/IP module must be dated 7/99 or newer. After you open PiCPro on your PC and before you open any file, check the date on your MMC EPROM by using the Online, Status menu item in PiCPro. The first item listed in the Communications Status box is the "Control EPROM version". If it is prior to 7/99, you will need to download the MMC01.hex file included on the CD you received. Use the PiCPro Online, Download hex command.

When the Download Hex box appears, follow these steps:

1. Using the Browse button, locate the MMC01.hex file.
2. Click on the appropriate baud rate.
3. Be sure the PiCPro port is selected.
4. Click on Start to begin downloading the hex file. Follow the prompts. They will tell you to turn the control off and then back on.

A status bar shows the progress of the download. If an error occurs, it will be reported in the Information Window.

## 17.5 Theory of operation

The MMCEthernet - TCP/IP module contains a 32-bit processor to handle TCP/IP, PPP (future), and Ethernet protocols. It allows you to use the Ethernet network architecture and the TCP/IP standard set of protocols to communicate and access other modules, computers, or the Internet and its resources. The design is based on the IEEE 802.3 specifications. The data rate is 10 Mbps. The diagram below provides an overview.

**Figure 17-5: MMC Ethernet - TCP/IP Overview**

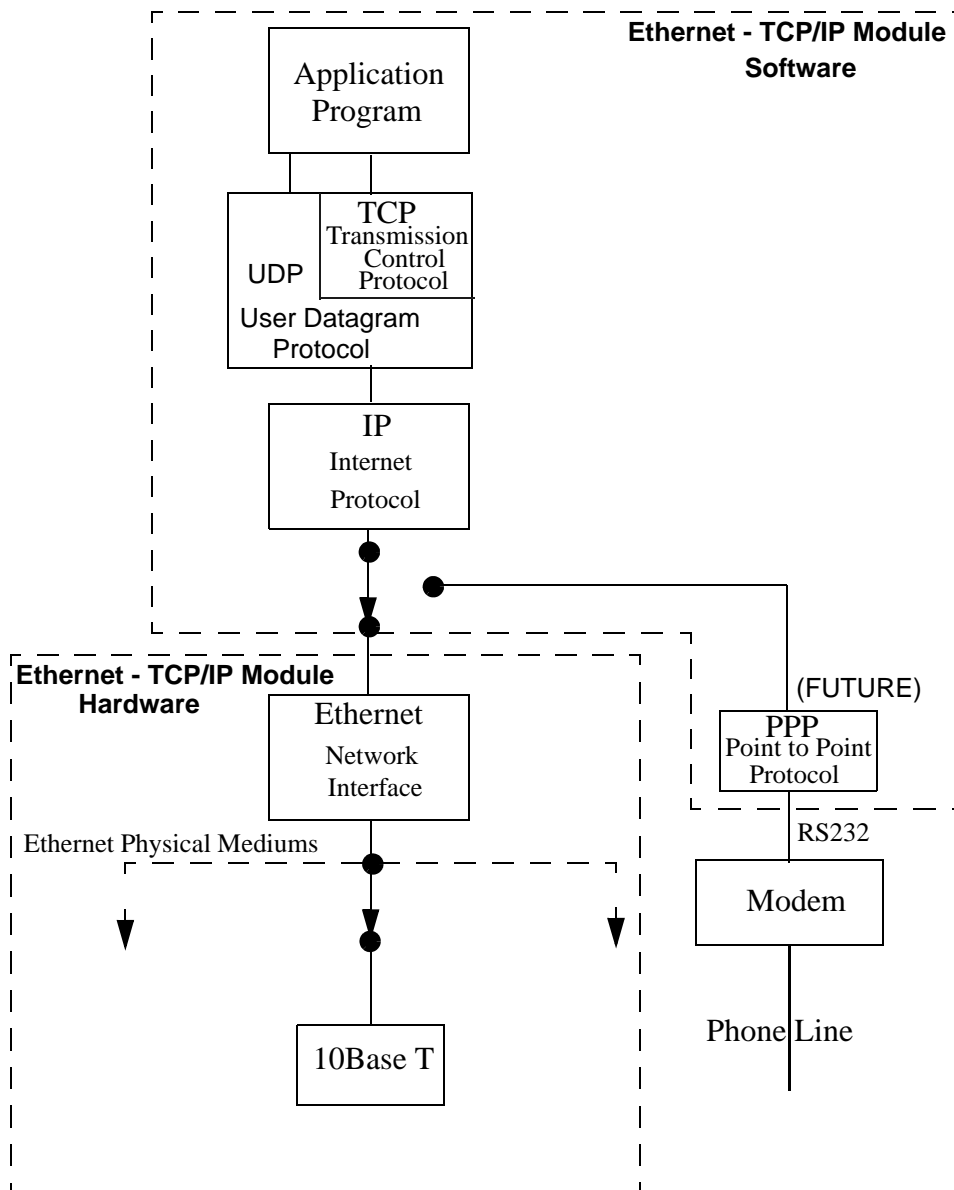

## 17.6 Specifications Table

Characteristics	Ethernet - TCP/IP Module Specifications
Function	Provides the MMC with Ethernet access and Internet connectivity
Part number	M.1017.3888
RS232 Port 1	Com Port 1 modem (future)
RS232 Port 2	Com Port 2 (for firmware and configuration loading)
10Base T	RJ-45 8-pin connector Maximum twisted pair length is 100 m (328 ft.).
24 VDC Power from the MMC	200 mA
Operating temperature range	7° C to 55° C (45° F to 131° F)
Storage temperature range	-40° C to 85° C (-40° F to 185° F)
Humidity	5 to 95%, non-condensing
CE Marked (Pending)	<p>Conforms to Directives 73/23/EEC, 89/336/EEC, 92/31/EEC, 93/68/EEC by conforming to the following standards:</p> <p>EN 50081-2:1993 EMC Generic Industrial Emissions            EN 50082-2:1995 EMC Generic Industrial Immunity            EN 61131-2:1994/A11:1996 Low voltage directive requirements for programmable controllers</p> <p>Operates with emissions below EN55011/ CISPR 11 Class A limits</p> <p>Immune to:</p> <ul style="list-style-type: none"> <li>• Electrostatic discharge (4K V contact mode, 8K V air discharge) per EN61000-4-2</li> <li>• RF electromagnetic fields per EN61000-4-3, ENV 50141, and ENV50204</li> <li>• Electrical fast transients per EN61000-4-4</li> <li>• Magnetic fields per EN61000-4-8</li> </ul> <p>Refer to the EMC Guidelines for more information.</p>
UL and C/UL Listed	E126417
Physical size	1.3" wide x 9.6" high x 5.3" deep 33 mm x 244 mm x 135 mm

Vibration (per IEC 68-2-6)	10-57 Hz (constant amplitude .15 mm) 57 - 2000 Hz (acceleration 2 g)
Shock (per IEC 68-2-27)	Four shocks per axis (15g/11 msec)

## 17.7 Useful Internet Links

[http://www.3com.com/technology/tech\\_net/white\\_papers/500698.html#6](http://www.3com.com/technology/tech_net/white_papers/500698.html#6)  
<http://www.library.ucg.ie/Connected/Course/index.htm>  
<http://www.combsnet.com/cable/Basics/types.html>  
[http://www.jdltech.com/solutions/Standards\\_Terms.cfm](http://www.jdltech.com/solutions/Standards_Terms.cfm)  
[http://www.jdltech.com/solutions/LAN\\_terms.cfm](http://www.jdltech.com/solutions/LAN_terms.cfm)  
[http://www.datatech.com/hot/w96\\_2.htm](http://www.datatech.com/hot/w96_2.htm)  
<http://www.standards.ieee.org/catalog/IEEE802.3.html>  
<http://www.3com.com/nsc/glossary/main.htm>  
[http://www.alliedtelesyn.com/prd\\_tran.htm#microtrans](http://www.alliedtelesyn.com/prd_tran.htm#microtrans)  
[http://www.lothlorien.net/collections/computer/ethernet\\_frames.html](http://www.lothlorien.net/collections/computer/ethernet_frames.html)  
<http://www.lantronix.com/htmfiles/mrktg/catalog/etntba.htm>  
<http://www.warehouse.com/datacomm/>



---

---

## 18 MMC DeviceNet™ Module

---

### 18.1 Introduction

The MMC DeviceNet™ scanner module is an interface between the MMC and a DeviceNet network. The module contains an on-board processor, a DeviceNet compliant interface, and firmware that makes it act as the master to all other nodes on the network.

Prior to initial operation, a file is generated with specific configuration software in an external PC. This file must be downloaded via the RS232 configuration port to the DeviceNet module prior to initial operation. Two indicator LEDs (IN/OUT) are connected to this configuration port.

Directly above the DeviceNet port are two LEDs that provide operation information: Network Status and DeviceNet Scanner Status.

The DIAG LED goes on briefly while the diagnostic tests are running.

**Figure 18-1: MMC DeviceNet Module**

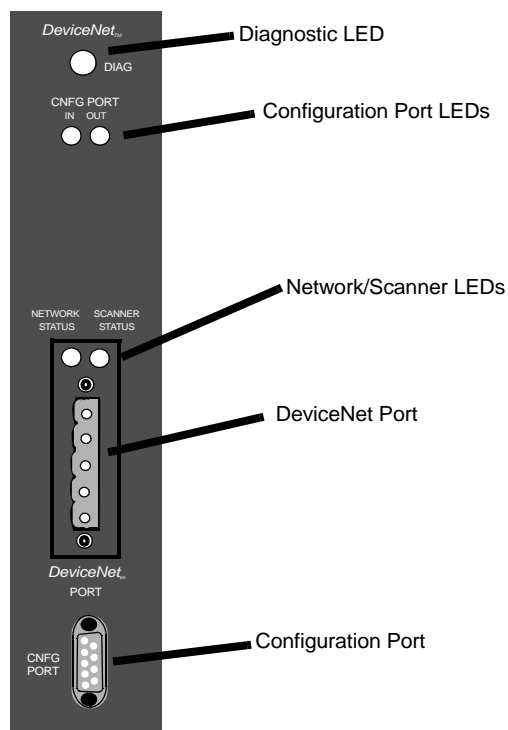

## 18.2 Connections

DeviceNet connections are illustrated in Figure 18-2 on page 90. Up to 63 DeviceNet Nodes may be attached to the DeviceNet scanner module.

**Figure 18-2: DeviceNet Connections**

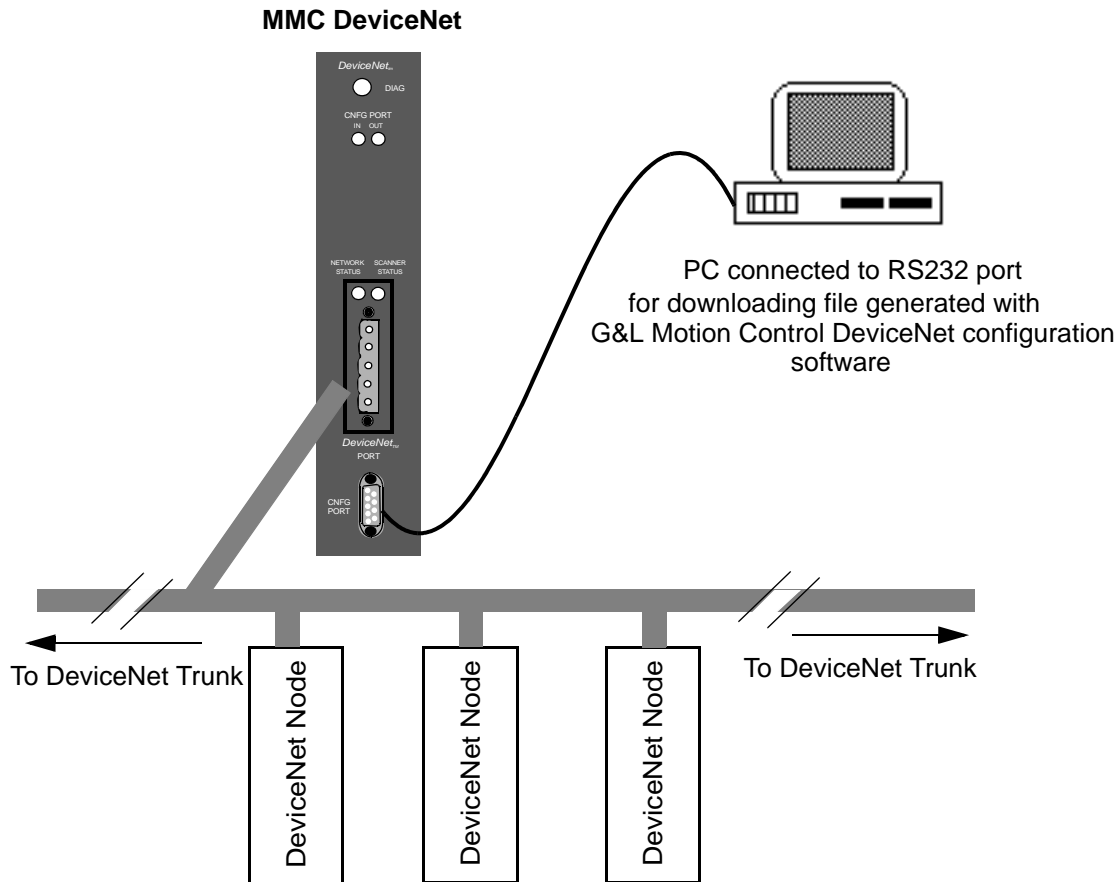

### 18.2.1 The DeviceNet Port

The DeviceNet port is on the front of the module near the center as shown in Figure 18-1 on page 89. The pinout for the DeviceNet port is shown below:

Pin #	Signal Name	Standard Wire Colors
1	V-	black
2	CAN_L	blue
3	Shield (drain)	bare
4	CAN_H	white
5	V+	red

In your network layout, follow DeviceNet specifications. Only use DeviceNet compliant cable, such as Belden 3084A thin wire and Belden 3082A thick wire.

### 18.2.2 The Configuration (RS232) Port

There is an RS232 port on the lower front of the module as shown in Figure 18-1 on page 89. This is used to connect to a PC in order to download a file representing your DeviceNet network.

Pin #	Signal Name	In/Out
2	Receive Data	In
3	Transmit Data	Out
5	Ground	In/Out

## 18.3 LEDs

The two configuration port LEDs and the two DeviceNet port LEDs are described below.

	LED	Color	State	Definition	
DeviceNet Port	Network status	None	OFF	Off-line	
		Green	ON	On-line and connected to at least one node	
			Flashing	On-line but connection nodes not established	
		Red	ON	Unrecoverable Fault (duplicate MAC ID check failed, critical bus fault etc.)	
			Flashing	I/O connections in timed-out state or other Recoverable Fault	
	Scanner status	Green	OFF		No power or else reset asserted
			ON		Scanner OK and active
			Flashing		Scanner OK but not active
		Red	ON		Hardware or software error
			Flashing		Recoverable configuration error (invalid data downloaded)
		Orange	ON		Configuration (download) mode
	Configuration Port	IN	Red	Flickering	Data is being passed to the module
				OFF	No data to the module
		OUT	Red	Flickering	Data is being passed from the module
			OFF	No data from the module	

## 18.4 Theory of Operation

The DeviceNet scanner module provides a memory image of the nodes (slaves) connected to a DeviceNet network. It is this memory image that is controlled by your LDO created in PiCPro. The module's on-board processor continually transfers data between this memory image and the actual DeviceNet nodes.

Communication between the DeviceNet module and the nodes can be set at 125 Kbaud, 250 Kbaud, or 500 Kbaud. The baud rate, the relationship between the memory image and specific data in each node, and other parameters are established with configuration software run in an external PC.

This configuration software generates two files. One file is downloaded to the DeviceNet module through its RS232 serial port. The other file is used by PiCPro to establish the relationship between the memory image and the declared variables in the LDO. To ensure that a given location in the memory image is connected to a variable in the LDO and to the corresponding data in the DeviceNet node, the same tag name or label must be used.

For example, when running the configuration software, PROX\_SW1 could be used as the name for the boolean bit representing a DeviceNet proximity switch's logic state. The name PROX\_SW1 must also be used for the corresponding variable in your LDO.

### NOTE

The G&L Motion Control DeviceNet configuration software (G&L Motion Control Part No. M.1017.4267) is required to configure the DeviceNet scanner (within the DeviceNet module) for the devices on the associated network.

### NOTE

Additional information about DeviceNet can be obtained from [www.odva.org](http://www.odva.org).

## 18.5 Specifications

Characteristics	DeviceNet Module Specifications
Function	Interfaces to a DeviceNet network with up to 63 other nodes
Part number	M.1017.3889
DeviceNet Port	Phoenix style 5-pin male connector
Configuration Port	RS232 interface
24 V DC Power from the MMC	100 mA
Operating temperature range	7° C to 55° C (45° F to 131° F)
Storage temperature range	-40° C to 85° C (-40° F to 185° F)
Humidity	5 to 95%, non-condensing
CE Marked	<p>Conforms to Directives 73/23/EEC, 89/336/EEC, 92/31/EEC, 93/68/EEC by conforming to the following standards:</p> <p>EN 50081-2:1993 EMC Generic Industrial Emissions  EN 50082-2:1995 EMC Generic Industrial Immunity  EN 61131-2:1994/A11:1996 Low voltage directive requirements for programmable controllers</p> <p>Operates with emissions below EN55011/ CISPR 11 Class A limits</p> <p>Immune to:</p> <ul style="list-style-type: none"> <li>• Electrostatic discharge (4K V contact mode, 8K V air discharge) per EN61000-4-2</li> <li>• RF electromagnetic fields per EN61000-4-3, ENV 50141, and ENV50204</li> <li>• Electrical fast transients per EN61000-4-4</li> <li>• Magnetic fields per EN61000-4-8</li> </ul> <p>Refer to the EMC Guidelines for more information.</p>
UL and C/UL Listed	File No. E126417 NRAQ Programmable Controllers
Physical size	1.3" wide x 9.6" high x 5.3" deep 33 mm x 244 mm x 135 mm
Vibration (per IEC 68-2-6)	10-57 Hz (constant amplitude .15 mm) 57 - 2000 Hz (acceleration 2 g)
Shock (per IEC 68-2-27)	Four shocks per axis (15g/11 msec)

---

---

## 19 MMC Profibus Module

---

### 19.1 Introduction

The MMC Profibus scanner module is an interface between the MMC and a Profibus network. The module contains an on-board processor, a Profibus compliant interface, and firmware that makes it act as the master to all other nodes on the network.

Prior to initial operation, a file is generated with specific configuration software in an external PC. This file must be downloaded via the RS232 configuration port to the Profibus module prior to initial operation. Two indicator LEDs (IN/OUT) are connected to this configuration port.

Directly above the Profibus port are two LEDs that provide operation information: Network Status and Profibus Scanner Status.

The DIAG LED goes on briefly while the diagnostic tests are running.

**Figure 19-1: MMC Profibus Module**

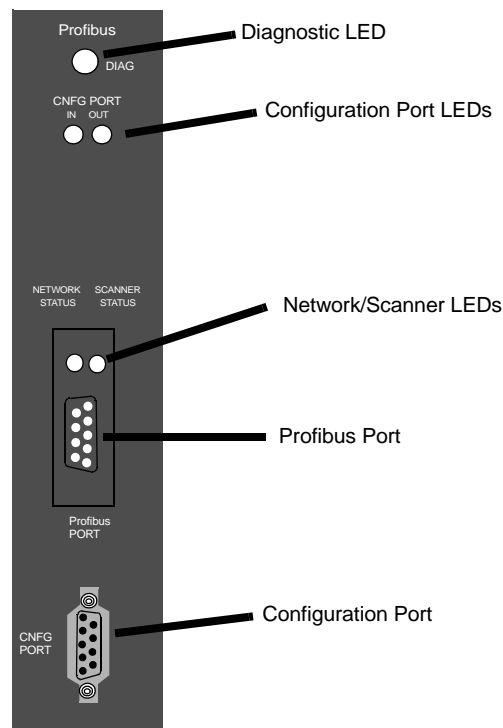

## 19.2 Connections

Profibus connections are illustrated in Figure 19-2. Up to 31 Profibus nodes, without repeaters, may be attached to the Profibus scanner. Up to 125 other Profibus Nodes, using repeaters, may be attached to the Profibus scanner module.

Figure 19-2: Profibus Connections

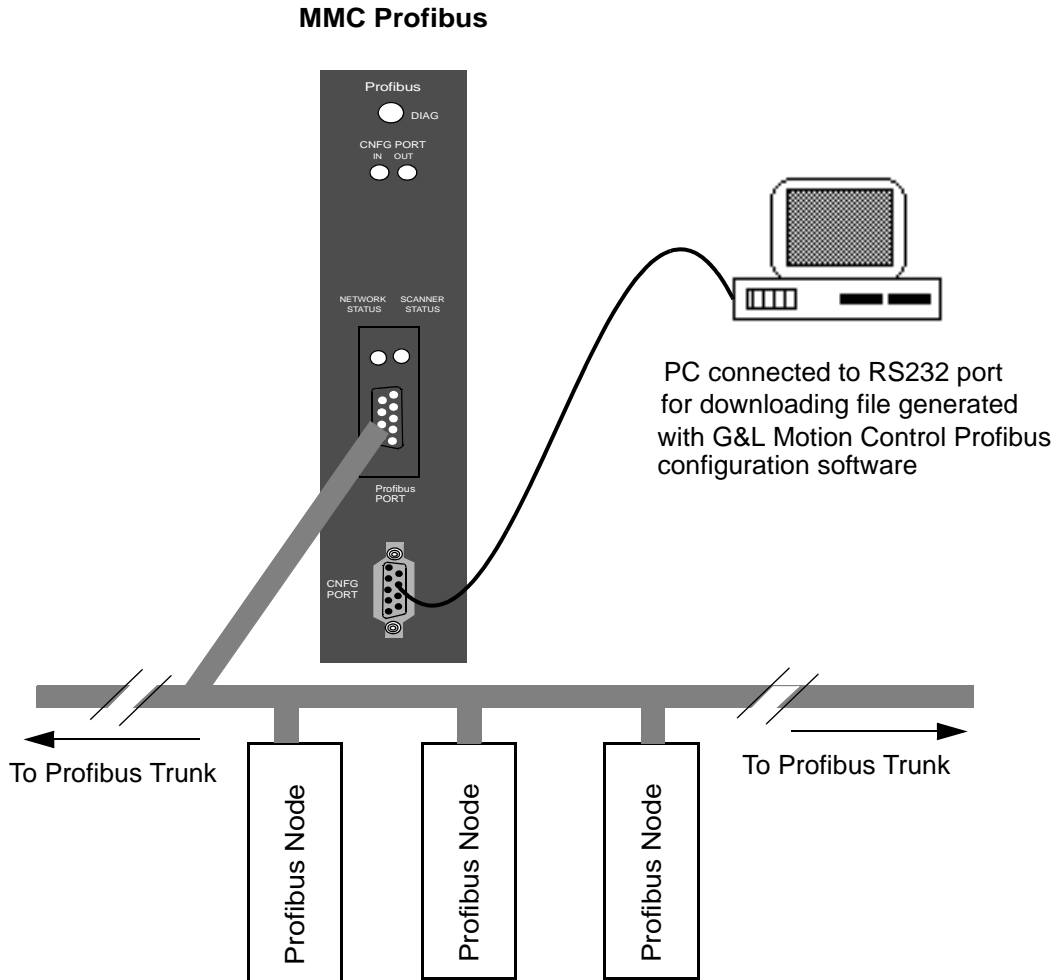



### 19.2.1 The Profibus Port

The Profibus port is on the front of the module near the center as shown in Figure 19-1. The pinout for the Profibus port is shown below.

**Table 19-1: Pinout for Profibus Port**

Pin #	Signal Name	Note:
1	Chassis ground	It is strongly recommended that you use Profibus Sub-D connectors with switchable (ON/OFF) termination, such as Siemens 6ES7 972-0BA11-0XA0 or 6ES7 972-0BB11-0XA0.  Only use Profibus type A cable, such as Belden 3079A or Siemens 6XV1 830-0AH10.
2	reserved	
3	data +	
4	Tx enable	
5	Isolated ground	
6	voltage plus	
7	reserved	
8	data -	
9	reserved	

### 19.2.2 The Configuration (RS232) Port

There is an RS232 port on the lower front of the module as shown in Figure 19-1. This is used to connect to a PC in order to download a file representing your Profibus network.

**Table 19-2: Pinout for RS232 Configuration Port**

Pin #	Signal Name	In/Out
2	Receive Data	In
3	Transmit Data	Out
5	Ground	In/Out

### 19.3 LEDs

The two configuration port LEDs and the two Profibus port LEDs are described below.

**Table 19-3: Description of Profibus Port LEDs**

	LED	Color	State	Definition	
<b>Profibus Port</b>	<b>Network status</b>	Green	OFF	Off-line	
			ON	On-line, no physical layer or data layer errors (or Profibus cable not connected)	
		Red	ON	On-line, bus error (baud rate or wiring problem)	
	<b>Scanner status</b>	Green	OFF	No power or else reset asserted, interface closed	
			ON	Scanner communicating, data exchanging, no slave device errors	
			Flashing	Scanner in start-up	
		Red	ON	At least one slave faulted	
		Orange	ON	Configuration (download) mode	
	<b>Configuration Port</b>	<b>IN</b>	Red	Flickering	Data is being passed to the module
				OFF	No data to the module
<b>OUT</b>		Red	Flickering	Data is being passed from the module	
			OFF	No data from the module	

## 19.4 Theory of Operation

The Profibus scanner module provides a memory image of the nodes (slaves) connected to a Profibus network. It is this memory image that is controlled by your LDO created in PiCPro. The module's on-board processor continually transfers data between this memory image and the actual Profibus nodes.

Communication between the Profibus module and the nodes can be set between 9600 baud (1200m max.) and 12M baud (100m max.). The baud rate, the relationship between the memory image and specific data in each node, and other parameters are established with configuration software run in an external PC.

This configuration software generates two files. One file is downloaded to the Profibus module through its RS232 serial port. The other file is used by PiCPro to establish the relationship between the memory image and the declared variables in the LDO. To ensure that a given location in the memory image is connected to a variable in the LDO and to the corresponding data in the Profibus node, the same tag name or label must be used.

For example, when running the configuration software, PROX\_SW1 could be used as the name for a boolean bit of a Profibus Block I/O. It would correspond to the wiring location of a proximity switch. The name PROX\_SW1 must also be used for the corresponding variable in your LDO.

The Profibus scanner module provides DP master Class 1 functionality only. This includes DP multi-master support (token) passing and cyclic slave communications. It does not support DP master Class 2, sync and freeze modes, nor extended DP functions.

### NOTE

The G&L Motion Control Profibus configuration software (G&L Motion Control Part No. M.1300.7794) is required to configure the Profibus scanner (within the Profibus module) for the devices on the associated network.

### NOTE

Additional information about Profibus can be obtained at [www.profibus.com](http://www.profibus.com)

## 19.5 Specifications for Profibus Module

Characteristics	Profibus Module Specifications
Function	Interfaces (acts as DP Master - Class 1), to a Profibus network with up to 125 other nodes, using repeaters
Part number	M.1300.7167
Profibus Port	9-pin female D-sub connector
Configuration Port	RS232 interface
24 V DC Power from the MMC	100 mA
Operating temperature range	7° C to 55° C (45° F to 131° F)
Storage temperature range	-40° C to 85° C (-40° F to 185° F)
Humidity	5 to 95%, non-condensing
CE Marked	<p>Conforms to Directives 73/23/EEC, 89/336/EEC, 92/31/EEC, 93/68/EEC by conforming to the following standards:</p> <p>EN 50081-2:1993    EMC Generic Industrial Emissions  EN 50082-2:1995    EMC Generic Industrial Immunity  EN 61131-2:1994/A11:1996 Low voltage directive requirements for programmable controllers</p> <p>Operates with emissions below EN55011/ CISPR 11 Class A limits</p> <p>Immune to:</p> <ul style="list-style-type: none"> <li>• Electrostatic discharge (4K V contact mode, 8K V air discharge) per EN61000-4-2</li> <li>• RF electromagnetic fields per EN61000-4-3, ENV 50141, and ENV50204</li> <li>• Electrical fast transients per EN61000-4-4</li> <li>• Magnetic fields per EN61000-4-8</li> </ul> <p>Refer to the EMC Guidelines for more information.</p>
UL and C/UL Listed	File No. E126417 NRAQ Programmable Controllers
Physical size	1.3" wide x 9.6" high x 5.3" deep 33 mm x 244 mm x 135 mm
Vibration (per IEC 68-2-6)	10-57 Hz (constant amplitude .15 mm) 57 - 2000 Hz (acceleration 2 g)
Shock (per IEC 68-2-27)	Four shocks per axis (15g/11 msec)

---

---

## 20 Axis I/O Option Module

---

Figure 20-1: Locations of Input, Output, Encoder Pins

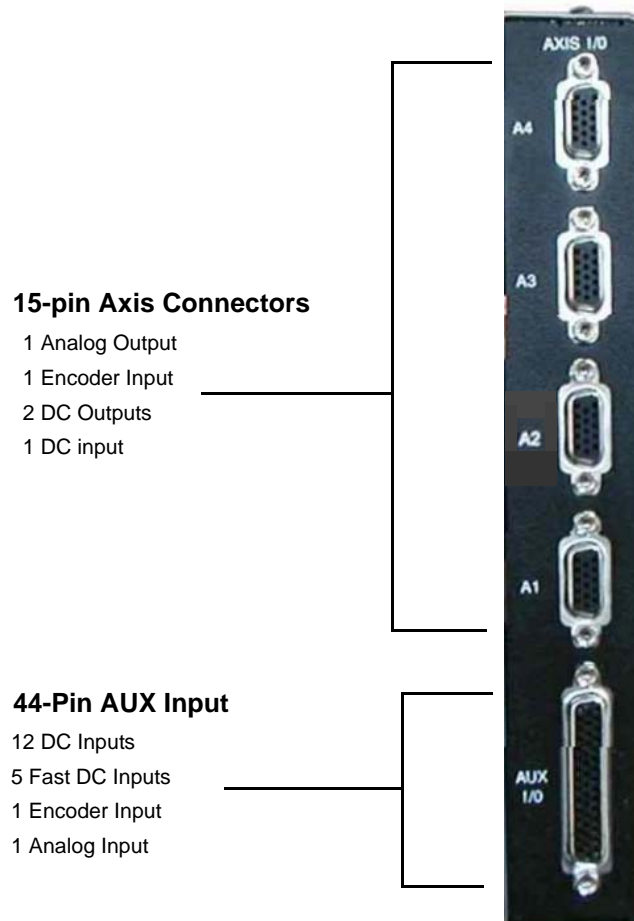

### 20.1 Analog Output Theory of Operation (Axis Connectors)

The CPU sends the analog output section a 16-bit digital word for each analog output channel used. Each digital word is converted to a corresponding voltage within the range of  $\pm 10$  V. The voltage is buffered and brought out to a pair of I/O connections as a differential type voltage output. This output is less subject to interference from electrical noise than a single-ended output would be.

You can adjust each analog output channel in software for offset adjustments, gain scaling, and unipolar outputs.

For safety reasons, all outputs are automatically reset to 0 V when a scan loss condition occurs.

## 20.2 Encoder Theory of Operation (Axis and AUX Connectors)

The encoder section uses differential type inputs to interface with up to five independent incremental encoders. These inputs accept RS422 level quadrature signals.

A *quadrature encoder* sends square wave type signals. When the shaft rotates at a constant velocity, the A and B outputs are square waves and are at the same frequency. However they are out of phase with each other by 90°. When the encoder shaft rotates in one direction, each A pulse leads the corresponding B pulse by 90°. When it rotates the other direction each A pulse lags its B pulse by 90°.

The signals illustrated in Figure 20-2 below indicate that the encoder shaft rotates in one direction at first. Its speed of rotation decreases to 0 and then it starts rotating the other direction. The signals are shown as differential.  $\bar{A}$  is the inverse of the signal A and  $\bar{B}$  is the inverse of signal B.

**Figure 20-2: Signals Transmitted by a Quadrature Encoder with Differential Outputs**

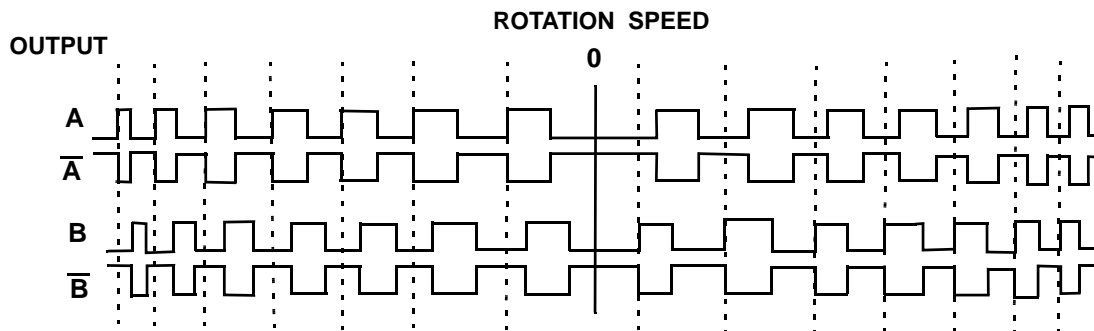

The maximum input frequency is 250,000 lines per second, which results in 1,000,000 Feedback Units (FUs) per second.

**Figure 20-3: Counting Quadrature Pulses**

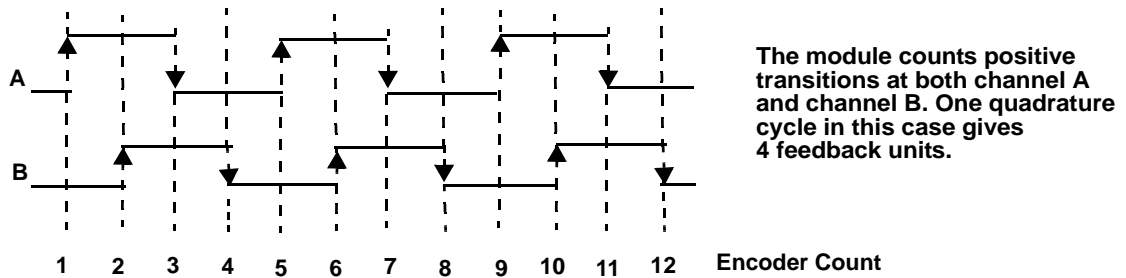

There is a 24-bit up/down counter for each channel. It is incremented or decremented on each A, B edge. There is also a 24-bit latch associated with each encoder channel.

The module can be programmed so that the counter value is "latched" or stored under one of these conditions:

- an index pulse from the encoder
- a positive or negative transition of the fast input
- the next index pulse after the required transition of the fast input

Each of the five 24-bit latches has a *fast 24 VDC input* associated with it. Each input is optically isolated. This input is intended to receive a signal from a device other than an encoder. It is typically used for referencing or synchronization purposes.

Fast input characteristics include:

- the detection of a signal occurs faster than it does for the DC inputs in other modules, due to less filtering. Because of this there is also less noise immunity.
- the response to a fast input signal is independent of ladder scan time. The module can be programmed to latch a position count as soon as this input is detected.

## 20.3 Analog Input Operation (AUX Connector)

There is one differential analog input channel on this module. The input range is  $\pm 10$  VDC. The analog input voltage is sampled every 100  $\mu$ sec by a 12-bit A/D converter. The most recent conversion result is stored in an on-board register. This register can be read at any time by the CPU.

The analog input signal passes through a common mode and differential mode filter prior to being applied to the A/D converter. These filters improve the noise immunity of the module.

## 20.4 Specifications

General	
Operating temperature range	5°C to 55°C (41°F to 131°F)
Storage temperature range	-40°C to 85°C (-40°F to 185°F)
Humidity	5 to 95%, non-condensing
CE Marked	<p>Conforms to Directives 73/23/EEC, 89/336/EEC, 92/31/EEC, 93/68/EEC by conforming to the following standards:</p> <p>EN 50081-2:1993EMC Generic Industrial Emissions            EN 50082-2:1995EMC Generic Industrial Immunity            EN 61131-2:1994/A11:1996 Low voltage directive requirements for programmable controllers            Operates with emissions below EN55011/ CISPR 11 Class A limits            Immune to:</p> <ul style="list-style-type: none"> <li>•Electrostatic discharge (4K V contact mode, 8K V air discharge) per EN61000-4-2</li> <li>•RF electromagnetic fields per EN61000-4-3, ENV 50141, and ENV50204</li> <li>•Electrical fast transients per EN61000-4-4</li> <li>•Magnetic fields per EN61000-4-8</li> </ul> <p>Refer to the EMC Guidelines for more information.</p>
UL and C/UL Listed	E126417
Physical size	2.25" wide x 9.6" high x 5.3" deep 57.15 mm x 243.84 mm x 134.62 mm
Vibration (per IEC 68-2-6)	10-57 Hz (constant amplitude .15 mm) 57 - 2000 Hz (acceleration 2 g)
Shock (per IEC 68-2-27)	Four shocks per axis (15g/11 msec)



<b>Analog Output</b>	
Output channels	2 or 4
Resolution	16 bits
Output voltage range	±10 VDC
Maximum output current (1K $\Omega$ load)	±10 mA
Power on output voltage	0 V ±100 mV
Scan loss output voltage	0V ±100 mV
Accuracy	±0.375% of FSR Drift ± 50ppm/°C
Update rate	68 $\mu$ sec
<b>Analog Input</b>	
Input channel	1
Resolution	12 bits
Input voltage range	±10 V
Accuracy	±0.2% of FSR
Sample rate	100 $\mu$ sec
Common mode filter	3 dB @ 10 K Hz
Differential mode filter	3 dB @ 475 Hz

<b>Encoder Input</b>	
Input channels	3 or 5
Input receiver	26632 differential RS422 receiver
Encoder signals	Differential quadrature
Input threshold	$\pm 750$ mV
Input termination	120 ohm, provided on board
Maximum input voltage	5 V
Maximum A or B input frequency	250 K Hz (1 M feedback unit count rate)
Fast input voltage	Nominal 24 VDC, maximum 30 VDC
Guaranteed on voltage	15 VDC
Guaranteed off voltage	5 VDC
Turn on/off time	1 ms
<b>Auxiliary and Axis DC Inputs</b>	
Configuration	The auxiliary inputs are divided into two groups of six inputs. Each group can be configured for sourcing or sinking. The axis inputs have one input per axis. Each input can be configured for sourcing or sinking. Operates with IEC Type 1 inputs (per IEC 1131=2).
Input voltage	Nominal 24 VDC, maximum 30 VDC
Guaranteed on voltage	15 VDC
Guaranteed off voltage	5 VDC
Turn on/off time	1 ms
Fast inputs	50 $\mu$ sec
<b>Axis DC Outputs</b>	
Number of outputs	2 outputs per axis
Configuration	Each set of axis outputs can be configured as sourcing or sinking.
Maximum current	100 mA per output
Voltage range	24 VDC nominal, 5 to 30 VDC range

Scan loss response	Outputs turn off
<b>Auxiliary DC Output</b>	
+5 VDC	150 mA maximum current available. Connections to this point should be over short distances and away from electric noise signals.



## 21 Breakout Boxes, Centurion Connector Cables and Flying Lead Cables

There are various plug and play connection products available for field wiring of the MMC control. These include Breakout Boxes with appropriate cable, Centurion MicroDSM drive J1 Cables, Centurion DSM drive J1 Cables and Flying Lead Cables.

Figure 21-1: Connection Selector Sheet for MMC Analog Control

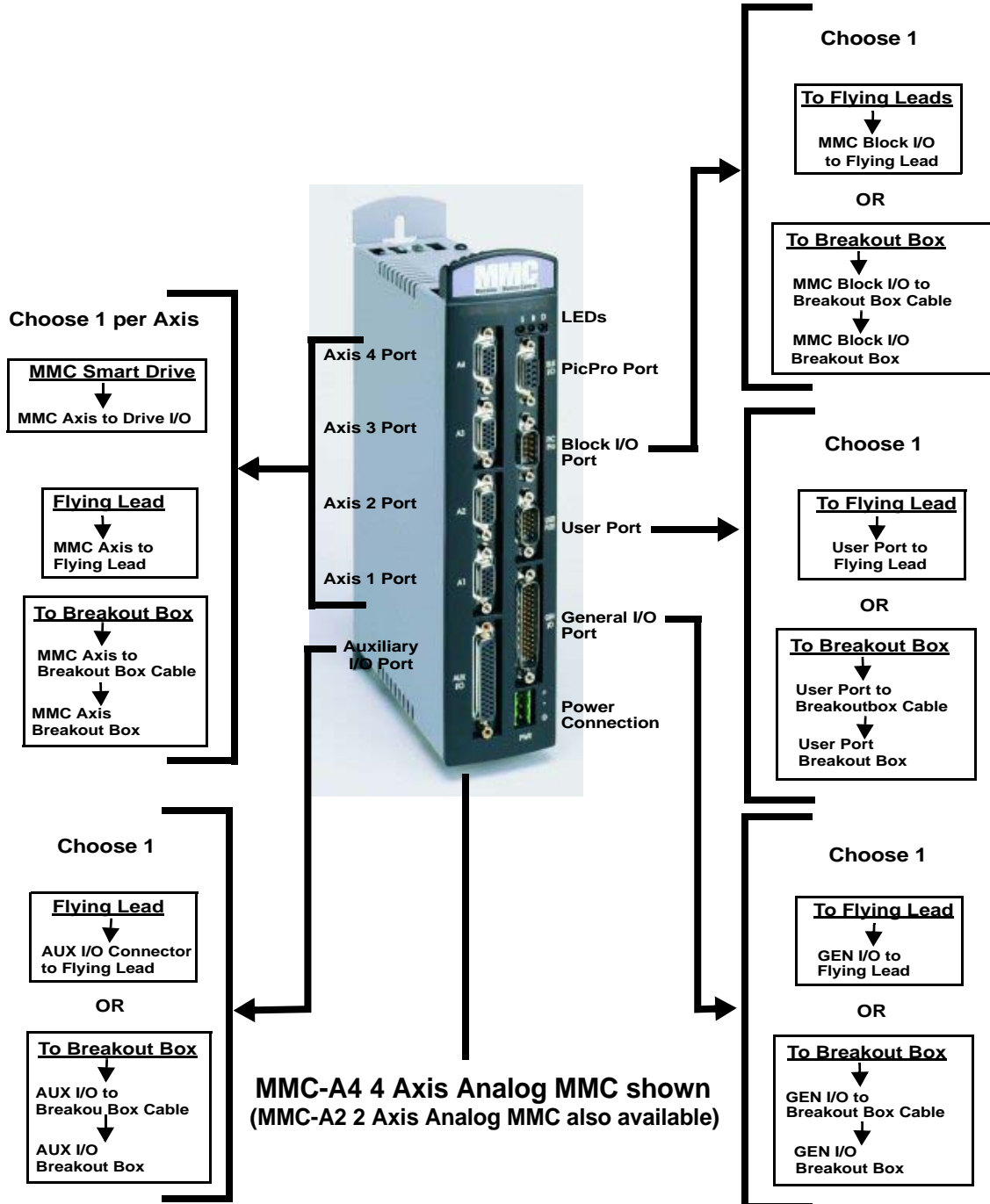
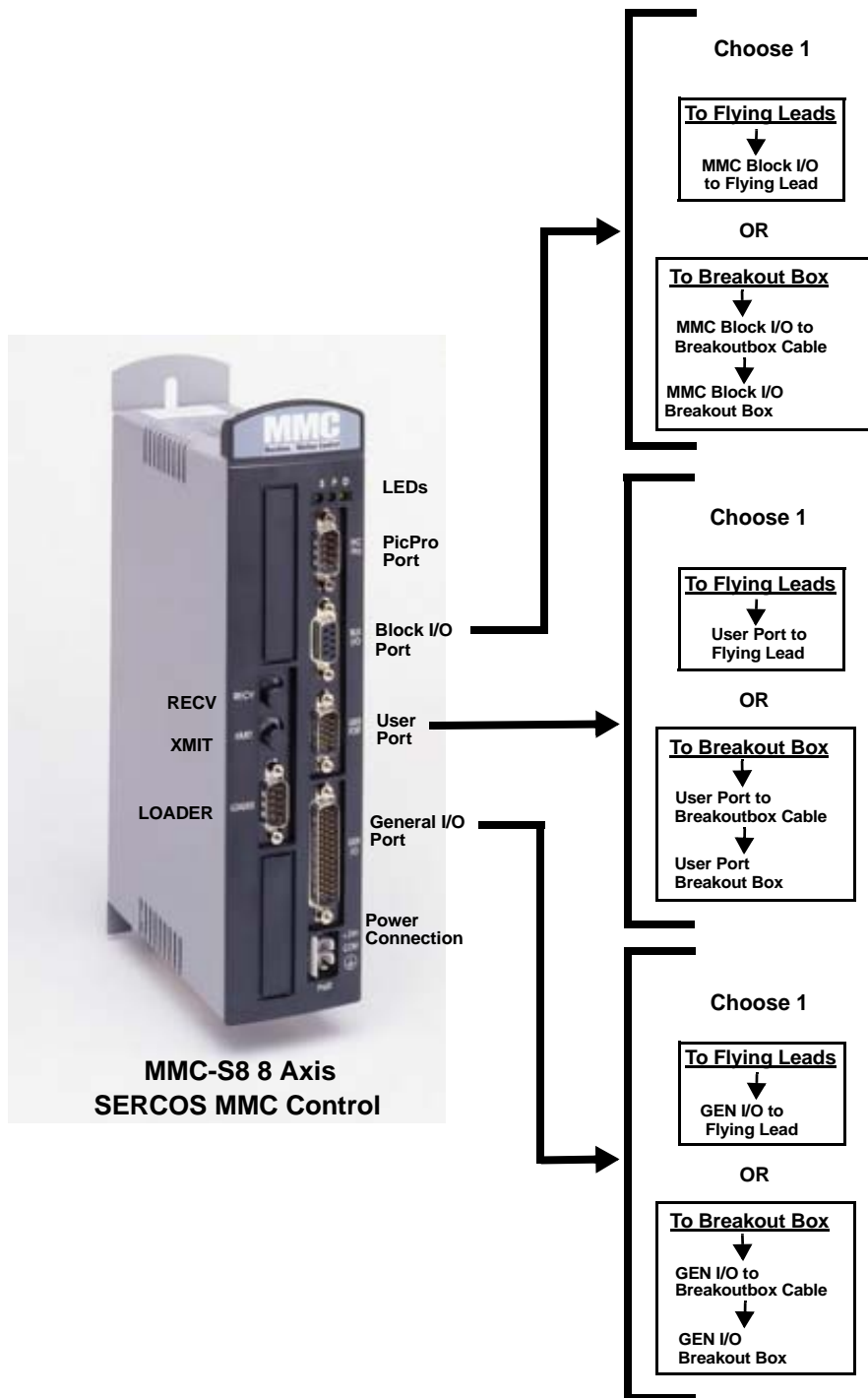

Figure 21-2: Connection Selector Sheet for MMC SERCOS Control



## **21.1 Breakout Boxes and Cables**

There are five basic and one encoder isolator type MMC Breakout Boxes available that simplify wire termination to the MMC Controls. They include the Axis Connector Breakout Box, Auxiliary I/O Connector Breakout Box, Auxiliary I/O Connector Breakout Box with Encoder Isolators, the User Port Connector Breakout Box, the General I/O Connector Breakout Box and the Block I/O Connector Breakout Box.

A screwdriver with a 0.4 x 2.5 mm blade tip must be used to make connections. When tightening screws, torque to 0.22 to 0.25 Nm. The recommended wire gauge is 30 - 16 AWG UL.

### **NOTE**

Axis connectors referred to in this section include those contained on the integrated Axis Module as well as those contained on the Axis I/O Option Module. MMC connectors referred to in this section include those contained on the MMC as well as those on the MMC Plus.

### **21.1.1 Breakout Box and Cables for Axis Connector**

**Table 21-1: Part No. - Breakout Box and Cables to MMC Axis Connector**

<b>(only for MMC Servo Control Axis Ports A1, A2, A3, A4)</b>		
<b>Description</b>	<b>Length</b>	<b>Part Number</b>
MMC Connector Breakout Box	N/A	M.1016.2529
MMC Axis A"n" to Breakout Box Cable	1'	M.1016.2535
MMC Axis A"n" to Breakout Box Cable	2'	M.1016.2536
MMC Axis A"n" to Breakout Box Cable	3'	M.1016.2537



### 21.1.1.1 Breakout Box for Axis Connector

The Breakout Box for the Axis Connector can be attached to A1, A2 A3 and A4 (one per axis) on the MMC or the Axis I/O Option Module. The pinouts on the terminal strip interface provide a one-to-one transfer of the signals from the connector to the respective pin(s) on the terminal block. The ground pin on the terminal strip provides a connection to the metal D-shell.

**Figure 21-3: Breakout Box - MMC Axis Connector**

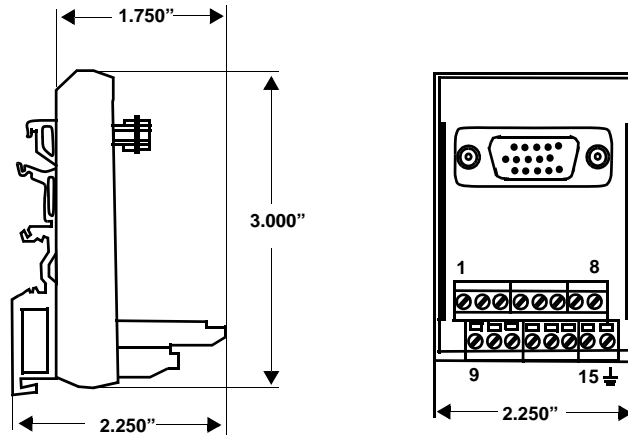

**Table 21-2: Pinout - Breakout Box for MMC Axis Connector**

Pin	Description	Pin	Description
1	A	9	DA-
2	A/	10	I/
3	B	11	+24 VDC out
4	B/	12	COM
5	I	13	DCOUT1
6	DCIN+	14	DCOUT2
7	DCIN-	15	DCOSS
8	DA+		Shell

### 21.1.1.2 Cable - Breakout Box to MMC Axis Connector

Figure 21-4: Cable for Axis Connector to Breakout Box

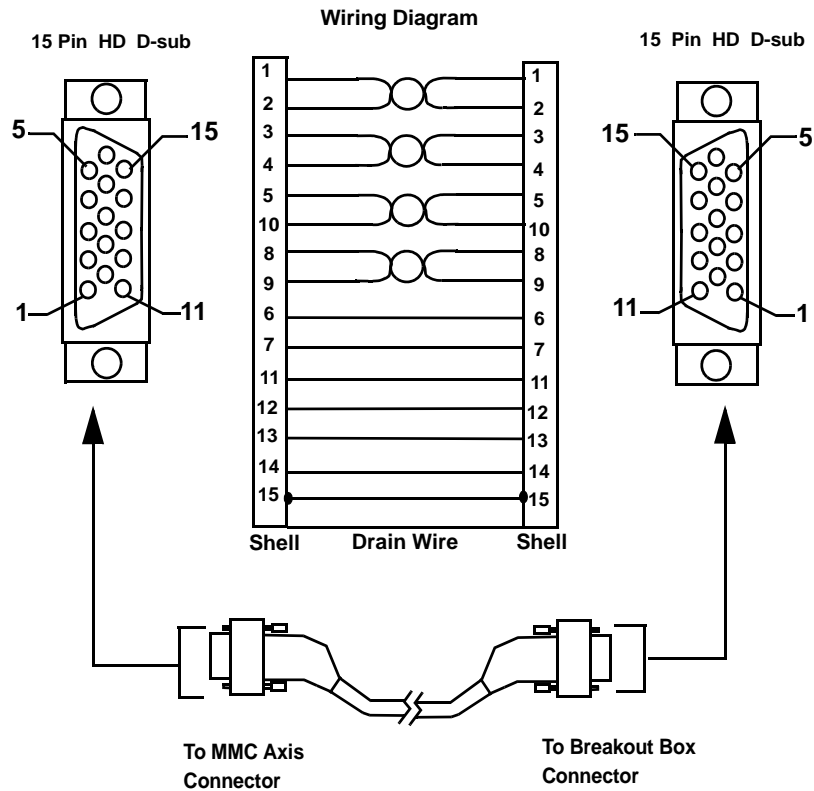

Table 21-3: Pinout - Cable for Axis Connector to Breakout Box

Pin	Description	Pin	Description
1	A	9	DA-
2	A/	10	I/
3	B	11	+24 VDC out
4	B/	12	COM
5	I	13	DCOUT1
6	DCIN+	14	DCOUT2
7	DCIN-	15	DCOSS
8	DA+	Shell	Drain (Shield)

## 21.1.2 Breakout Box and Cables for Auxiliary I/O Connector

**Table 21-4: Part No. - Breakout Box and Cables to MMC AUX I/O Connector**

Description	Length	Part Number
MMC Aux I/O Breakout Box	N/A	M.1016.2531
MMC Connector Breakout Box with Encoder Isolation	N/A	M.1016.4236
MMC Gen/Aux I/O Connector to Breakout Box Cable	1'	M.1016.2539
MMC Gen/Aux I/O Connector to Breakout Box Cable	2'	M.1016.2540
MMC Gen/Aux I/O Connector to Breakout Box Cable	3'	M.1016.2541

### 21.1.2.1 Breakout Box for AUX I/O Connector

On the analog MMC or the Axis I/O Option Module, the Aux I/O connector contains the fast inputs for each axis (including the half axis encoder input) for registration and hardware interrupt capability. It also contains the differential encoder input for the half axis, one analog input, and three 24VDC discrete inputs for each closed loop axis. Typically these inputs would be used for plus and minus end of travel limits and for the reference switch. However, they can be used as general purpose inputs if they are not being used for end-of-travel and reference switch.

The Auxiliary Connector Breakout Box is attached to the AUX I/O connector on the MMC Control. The connector pins marked with the "ground" symbol on the screw connector are connected to the "D" connector shell for shield grounding purposes. The pinouts on the terminal strip interface provide a one-to-one transfer of the signals from the connector to the respective pin(s) on the terminal block.

**Figure 21-5: Breakout Box - Auxiliary I/O Connector**

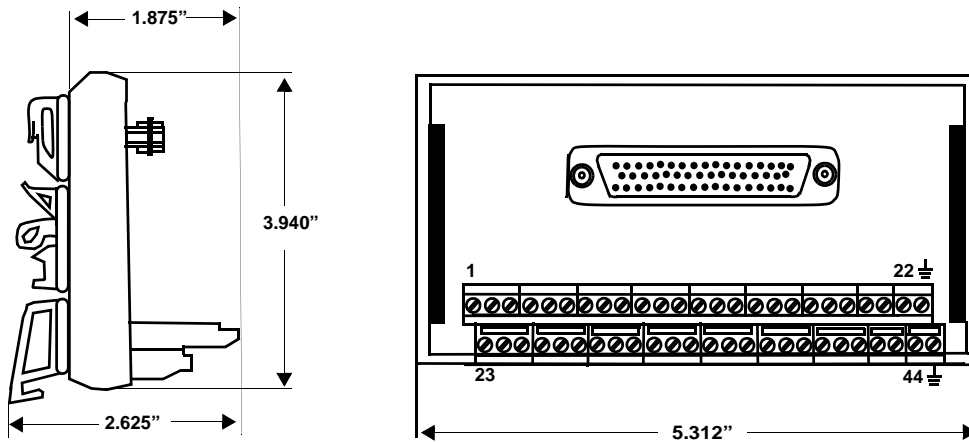

**Table 21-5: Pinout - Breakout Box Auxiliary I/O Connector MMC-A4 (4 axis) and MMC Axis I/O Option Module**

Pin	Description	Pin	Description	Pin	Description
1	A	16	FASTIN1+	31	DCSSA
2	A/	17	FASTIN1-	32	DCIN1
3	B	18	SHIELD	33	DCIN2
4	B/	19	FASTIN2+	34	DCIN3
5	I	20	FASTIN2-	35	DCIN4
6	I/	21	SHIELD	36	DCIN5
7	SHIELD	22	FASTIN3+	37	DCIN6
8	+24 VDC out	23	FASTIN3-	38	DCSSB
9	+24 VDC out	24	SHIELD	39	DCIN7
10	COM	25	FASTIN4+	40	DCIN8
11	COM	26	FASTIN4-	41	DCIN9
12	+5 VDC out	27	SHIELD	42	DCIN10
13	ANLGIN+	28	FASTIN5+	43	DCIN11
14	ANLGIN-	29	FASTIN5-	44	DCIN12
15	SHIELD	30	SHIELD	⏏	Shell (Shield)
				⏏	Shell (Shield)

**Table 21-6: Pinout - Breakout Box Auxiliary I/O Connector MMC-A2 (2 axis)**

Pin	Description	Pin	Description	Pin	Description
1	A	16	FASTIN1+	31	DCSSA
2	A/	17	FASTIN1-	32	DCIN1
3	B	18	SHIELD	33	DCIN2
4	B/	19	FASTIN2+	34	DCIN3
5	I	20	FASTIN2-	35	DCIN4
6	I/	21	SHIELD	36	DCIN5
7	SHIELD	22	NC	37	DCIN6
8	+24 VDC out	23	NC	38	NC
9	+24 VDC out	24	SHIELD	39	NC
10	COM	25	NC	40	NC
11	COM	26	NC	41	NC
12	+5 VDC out	27	SHIELD	42	NC
13	ANLGIN+	28	FASTIN5+	43	NC
14	ANLGIN-	29	FASTIN5-	44	NC
15	SHIELD	30	SHIELD	 Shell (Shield)	

### 21.1.2.2 Auxiliary I/O Connector Breakout Box with Encoder Isolators

A second type of auxiliary I/O breakout box has encoder isolator circuits incorporated into the module. These circuits boost the encoder common mode voltages allowed from approximately 10 volts to hundreds of volts. This allows reliable encoder operation in the presence of large amounts of electrical noise and ground disturbances relative to the MMC unit.

The Breakout Box for the Auxiliary I/O Connector with Encoder Isolators is attached to the AUX I/O connector on the MMC or Axis I/O Option Module. The connector pins marked with the "ground" symbol on the screw connector are connected to the "D" connector shell for shield grounding purposes.

The pinouts on the screw terminal strip are identical to those of the breakout boxes for the Auxiliary I/O Connector except that 5V is not brought out on screw terminal 12 and the encoder inputs are optically isolated.

**Figure 21-6: Breakout Box - Auxiliary I/O Connector with Encoder Isolators**

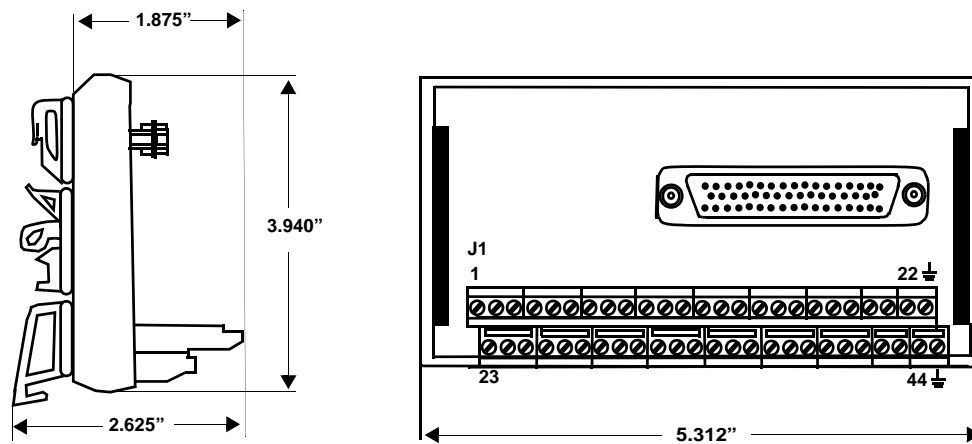

### 21.1.2.3 Encoder Isolator Connections

Figure 21-7: Connections from Encoder to Encoder Isolated AUX I/O

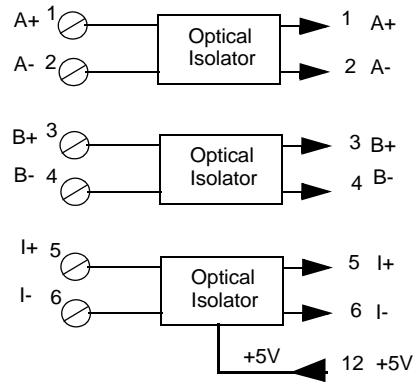

**Note:** Pin 12, the +5V ( $\pm 20\%$ ), is not carried thru to the screw terminal. (The pin is insufficient to provide power to an encoder; an external 5V supply is required for an encoder.)

Figure 21-8: Encoder and Power Connections for Encoder Isolator

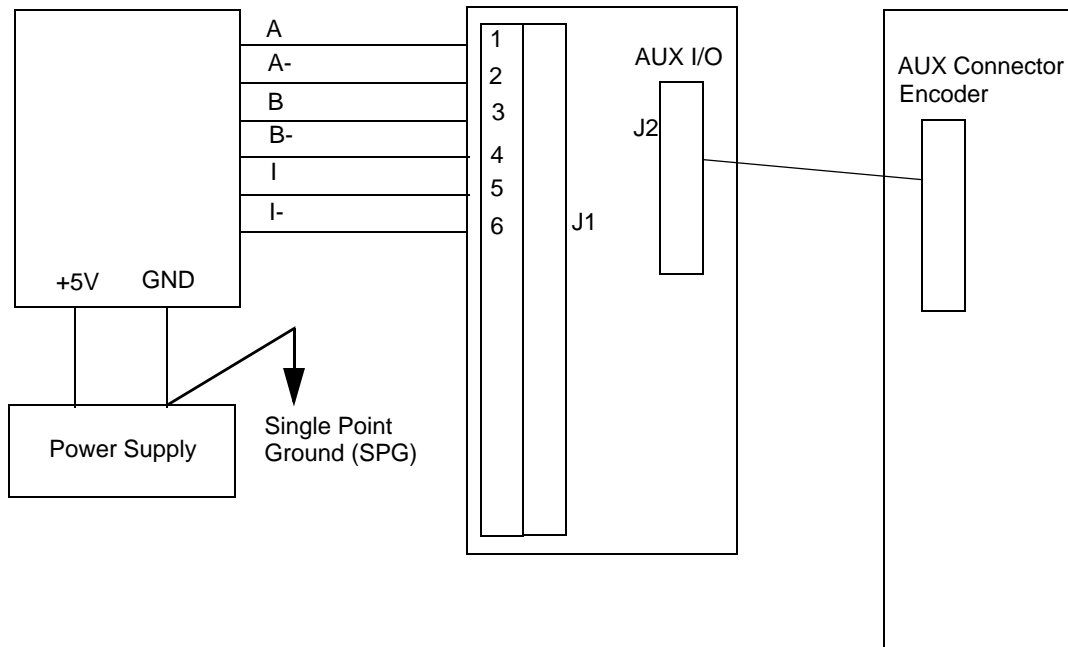

#### 21.1.2.4 Input Requirements for Encoder Isolator Breakout Box

A RS-422 differential type driver is required.

**Table 21-7: Encoder Isolator Breakout Box Input Requirements**

<b>Input Item</b>	<b>Specification</b>
Input current/voltage (minimum)	2.5ma @ 2.5 volts
Input current/voltage (maximum)	22ma @ 7.0 volts
Input pulse width (minimum)	600 nanoseconds
Input frequency (maximum) on A or B inputs from Quadrature output encoder	250KHz (1.0 MHz count rate, using quadrature edges)
Input frequency (maximum) on A or B inputs from Pulse output encoder	500KHz (500KHz count rate)



### 21.1.2.5 Cable - Breakout Box to AUX I/O Connector

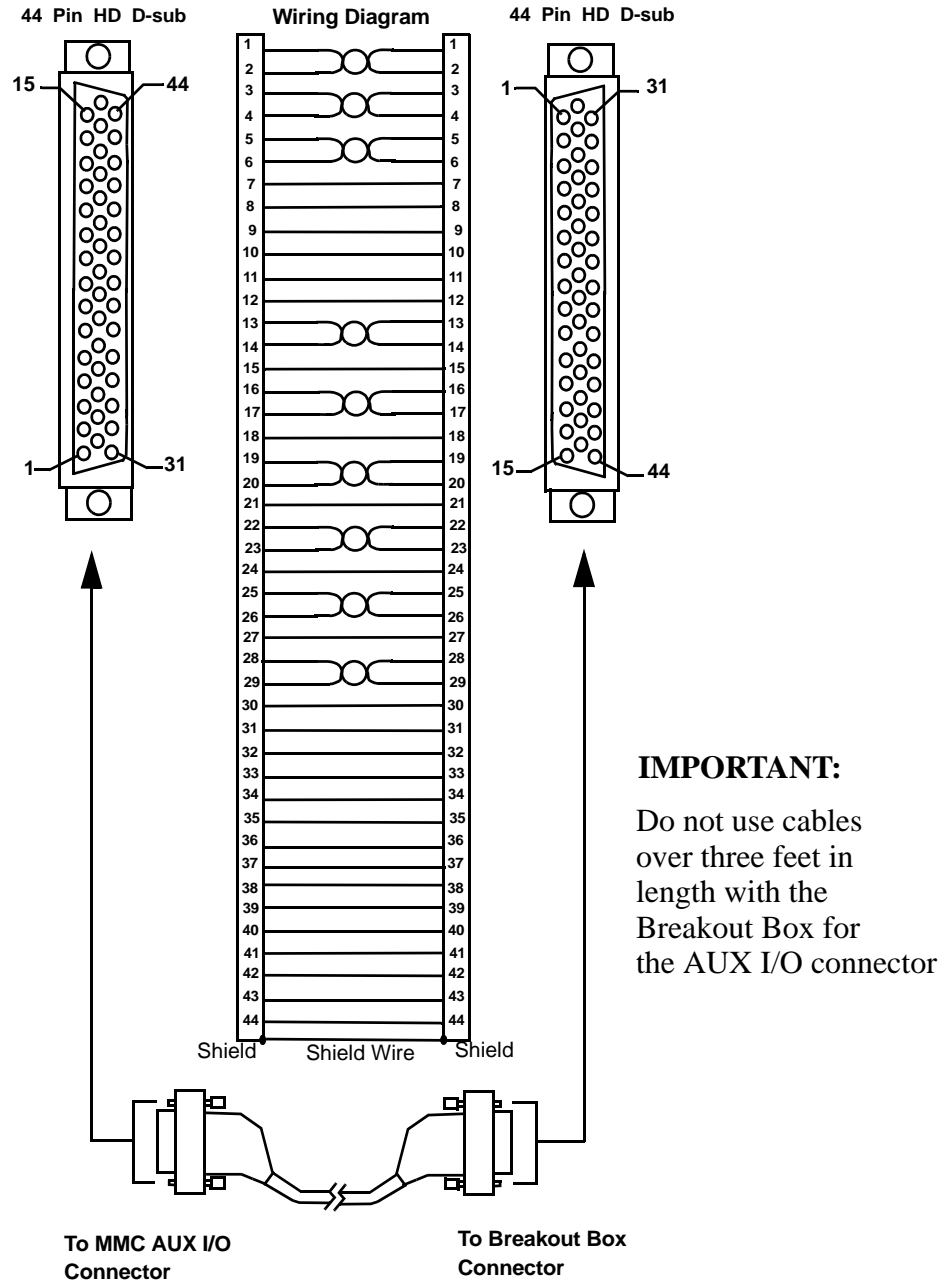

Figure 21-9: Cable for AUX I/O Connector to Breakout Box





**IMPORTANT**

The MMC Gen I/O connector cable at the MMC (female connection) is compatible with the MMC Aux I/O breakout box connector cable. Similarly, the MMC Aux I/O connector cable at the MMC (male connection) is compatible with the MMC Gen I/O breakout box connector cable. With this compatibility, the cables between the MMC Aux/Gen connectors and the Aux/Gen breakout boxes are the same. To move a cable from one to the other, just swap the cable ends.

**Table 21-8: Pinout - Cable for AUX I/O Connector to Breakout Box (MMC-A4 and Axis I/O Option Module)**

Pin	Description	Pin	Description	Pin	Description
1	A	16	FASTIN1+	31	DCSSA
2	A/	17	FASTIN1-	32	DCIN1
3	B	18	SHIELD	33	DCIN2
4	B/	19	FASTIN2+	34	DCIN3
5	I	20	FASTIN2-	35	DCIN4
6	I/	21	SHIELD	36	DCIN5
7	SHIELD	22	FASTIN3+	37	DCIN6
8	+24 VDC out	23	FASTIN3-	38	DCSSB
9	+24 VDC out	24	SHIELD	39	DCIN7
10	COM	25	FASTIN4+	40	DCIN8
11	COM	26	FASTIN4-	41	DCIN9
12	+5 VDC out	27	SHIELD	42	DCIN10
13	ANLGIN+	28	FASTIN5+	43	DCIN11
14	ANLGIN-	29	FASTIN5-	44	DCIN12
15	SHIELD	30	SHIELD		Shell (Shield)
					Shell (Shield)

**Table 21-9: Pinout - Cable for AUX I/O Connector to Breakout Box (MMC-A2, MMC-A2 Plus)**

Pin	Description	Pin	Description	Pin	Description
1	A	16	FASTIN1+	31	DCSSA
2	A/	17	FASTIN1-	32	DCIN1
3	B	18	SHIELD	33	DCIN2
4	B/	19	FASTIN2+	34	DCIN3
5	I	20	FASTIN2-	35	DCIN4
6	I/	21	SHIELD	36	DCIN5
7	SHIELD	22	NC	37	DCIN6
8	+24 VDC out	23	NC	38	NC
9	+24 VDC out	24	SHIELD	39	NC
10	COM	25	NC	40	NC
11	COM	26	NC	41	NC
12	+5 VDC out	27	SHIELD	42	NC
13	ANLGIN+	28	FASTIN5+	43	NC
14	ANLGIN-	29	FASTIN5-	44	NC
15	SHIELD	30	SHIELD		Shell (Shield)
					Shell (Shield)

## 21.1.3 Breakout Box and Cables for Block I/O Connector

### 21.1.3.1 Block I/O Connector Breakout Box

The Block I/O connector is used for communicating with distributed block I/O modules. Up to 77 blocks can be connected to a single MMC. A complete family of block I/O modules are available, including AC and DC discrete I/O, analog I/O, stepper and resolver.

The Block I/O Connector Breakout Box is attached to the BLK I/O connector on the MMC Control. The pinouts on the terminal strip interface provide a one-to-one transfer of the signals from the connector to the respective pin(s) on the terminal block.

**Table 21-10: Part No. - Breakout Box and Cables to MMC BLK I/O Connector**

Description	Length	Part Number
MMC Block I/O Breakout Box	N/A	M.1016.2533
MMC Block I/O Connector to Breakout Box Cable	1'	M.1016.2543
MMC Block I/O Connector to Breakout Box Cable	2'	M.1016.2544
MMC Block I/O Connector to Breakout Box Cable	3'	M.1016.25415

**Figure 21-10: Breakout Box - BLK I/O Connector**

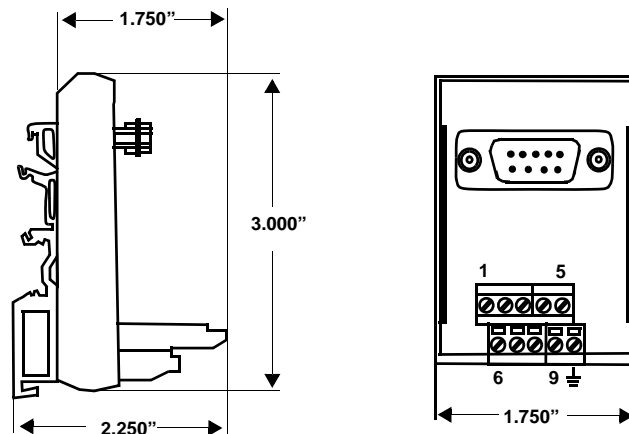

**Table 21-11: Pinout - Breakout Box for Block I/O Connector**

Pin	Desc.	In/Out	Pin	Desc.	In/Out	Pin	Desc.	Pin
1	NC		4	Block I/O Transmit Data -	Out	7	Shield (see Note below)	
2	NC		5	Block I/O Receive Data +	In	8	NC	
3	Block I/O Transmit Data +	Out	6	Block I/O Receive Data -	In	9	NC	
							Shell (Shield)	
<p><b>NOTE:</b> Pin 7 of the Block I/O connector is connected to the connector shell within the MMC. Therefore, the shield may be connected to either pin 7 or the connector shell.</p>								

### 21.1.3.2 Cable - Breakout Box to Block I/O Connector

Figure 21-11: Cable for Block I/O Connector to Breakout Box

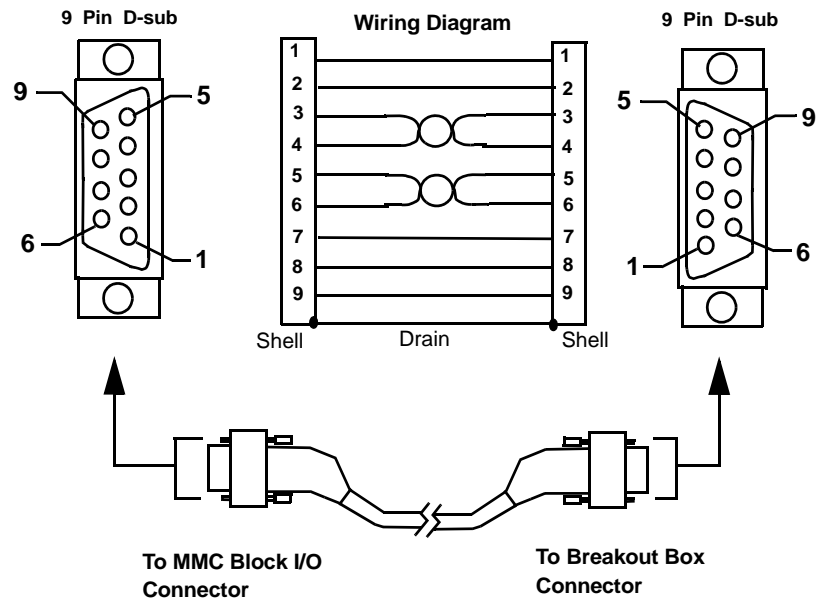

Table 21-12: Pinout - Cable for BLK I/O Connector to Breakout Box

Pin	Description	In/Out
1	NC	
2	NC	
3	Block I/O Transmit Data +	Out
4	Block I/O Transmit Data -	Out
5	Block I/O Receive Data +	In
6	Block I/O Receive Data -	In
7	Shield	
8	NC	
9	NC	

## 21.1.4 Breakout Box and Cables for User Port Connector

### 21.1.4.1 User Port Connector Breakout Box

The User Port connector on the MMC control is a serial port typically used for operator interface. The User Port Connector Breakout Box is attached to the USER PORT connector on the MMC control. The pinouts on the terminal strip interface provide a one-to-one transfer of the signals from the connector to the respective pin(s) on the terminal block.

**Table 21-13: Part No. - Breakout Box and Cables to MMC User Port**

Description	Length	Part Number
MMC User Port Breakout Box	N/A	M.1016.2530
MMC User Port to Breakout Box Cable	1'	M.1016.2715
MMC User Port to Breakout Box Cable	2'	M.1016.2716
MMC User Port to Breakout Box Cable	3'	M.1016.2717

**Figure 21-12: User Port Connector Breakout Box**

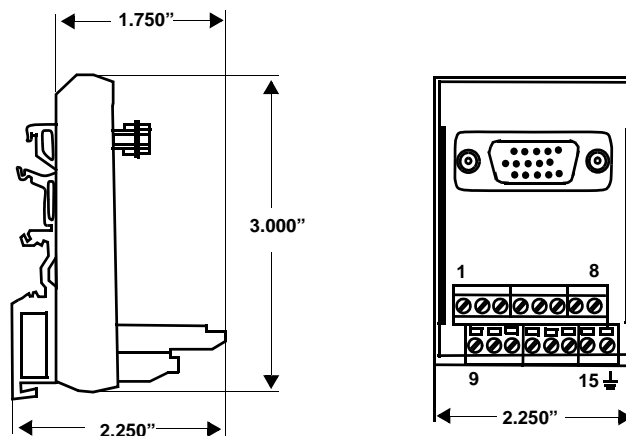

**Table 21-14: Pinout - Breakout Box for User Port**

Pin	Description	In/Out	Pin	Description	In/.Out
1	NC		9	RS232 Receive Data	In
2	NC		10	RS232 Transmit Data	Out
3	+5V (50mA Max)	Out	11	NC	
4	RS232 Data Terminal Ready	Out	12	RS485 Receive Data +	In
5	RS232 Request to Send	Out	13	RS485 Receive Data -	In
6	NC		14	RS485 Transmit Data +	Out
7	RS232 Clear to Send	In	15	RS485 Transmit Data -	Out
8	Signal Ground	In/Out		Shell (Shield)	



### 21.1.4.2 Cable - Breakout Box to User Port Connector

Figure 21-13: Cable for User Port Connector to Breakout Box

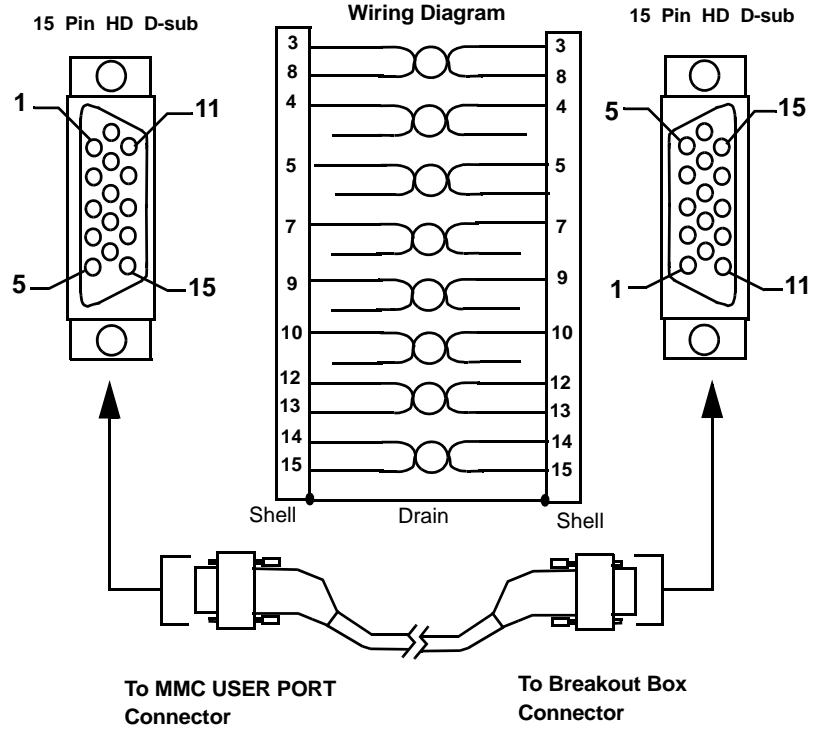

Table 21-15: Pinout - Cable for User Port Connector to Breakout Box

Pin	Description	In/Out	Pin	Description	In/.Out
1	NC		9	RS232 Receive Data	In
2	NC		10	RS232 Transmit Data	Out
3	+5V (50mA Max)	Out	11	NC	
4	RS232 Data Terminal Ready	Out	12	RS485 Receive Data +	In
5	RS232 Request to Send	Out	13	RS485 Receive Data -	In
6	NC		14	RS485 Transmit Data +	Out
7	RS232 Clear to Send	In	15	RS485 Transmit Data -	Out
8	Signal Ground	In/Out	Shell	Drain (shield)	

## 21.1.5 Breakout Box and Cables for General I/O Connector

**Table 21-16: Part No. - Breakout Box and Cables to MMC GEN I/O Connector**

Description	Length	Part Number
MMC Gen I/O Breakout Box	N/A	M.1016.2532
MMC Gen/Aux I/O Connector to Breakout Box Cable	1'	M.1016.2539
MMC Gen/Aux I/O Connector to Breakout Box Cable	2'	M.1016.2540
MMC Gen/Aux I/O Connector to Breakout Box Cable	3'	M.1016.2541

### 21.1.5.1 Breakout Box for GEN I/O Connector



The Gen I/O connector contains sixteen general-purpose 24 VDC discrete inputs (sink or source) and sixteen general-purpose 24 VDC discrete outputs (source only). Any of the 16 outputs can be used as CAM or PLS outputs. Two of the inputs (number 1 and number 9) have hardware interrupt capability and can be used to trigger hardware interrupt tasks in the application program.

The General I/O Connector Breakout Box is connected to the GEN I/O connector on the MMC Control. The pinouts on the terminal strip interface provide a one-to-one transfer of the signals from the connector to the respective pin(s) on the terminal block.

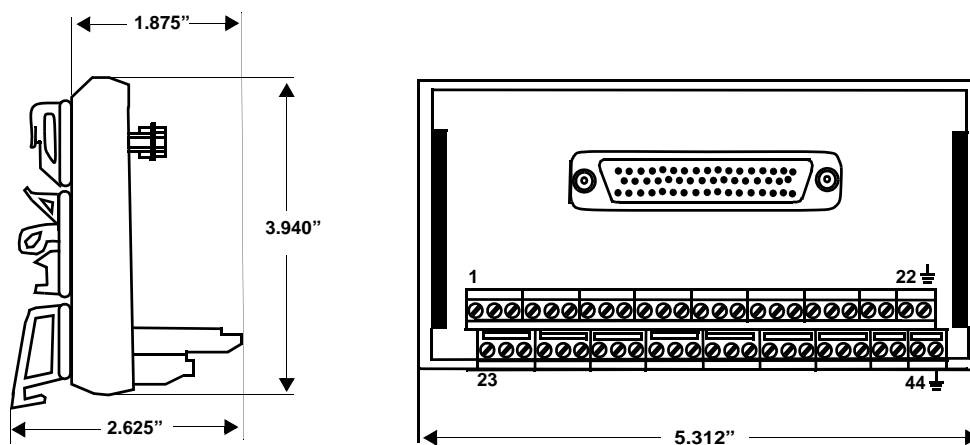
**Figure 21-14: General I/O Connector Breakout Box**

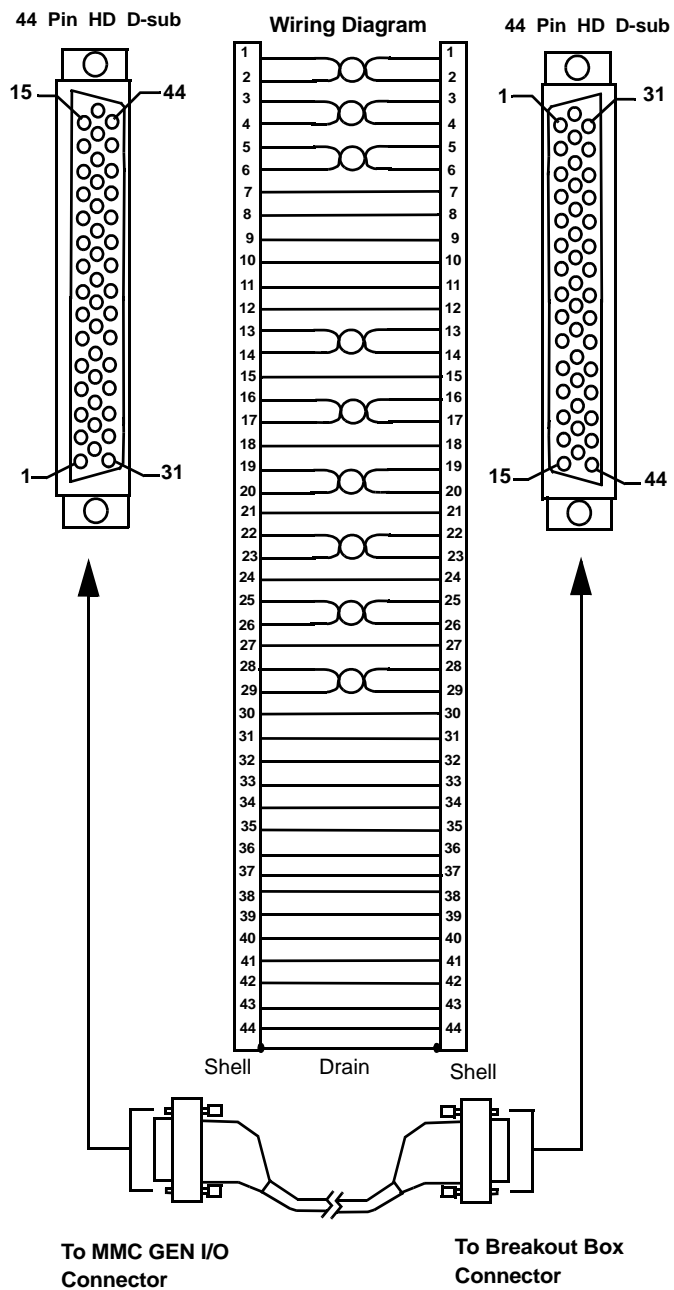

**Table 21-17: Pinout - Breakout Box for GEN I/O Connector**

Pin	Description	In/Out	Pin	Description	In/Out	Pin	Description	In/Out
1	DCOUT1	Out	16	DCOUT16	Out	31	NC	
2	DCOUT2	Out	17	NC		32	NC	
3	DCOUT3	Out	18	NC		33	NC	
4	DCOUT4	Out	19	NC		34	IO24V	Out
5	DCOUT5	Out	20	IO24V	Out	35	DCSS2	In
6	DCOUT6	Out	21	DCSS1	In	36	IO24C	Out
7	DCOUT7	Out	22	IO24C	Out	37	DCIN9	In
8	DCOUT8	Out	23	DCIN1	In	38	DCIN10	In
9	DCOUT9	Out	24	DCIN2	In	39	DCIN11	In
10	DCOUT10	Out	25	DCIN3	In	40	DCIN12	In
11	DCOUT11	Out	26	DCIN4	In	41	DCIN13	In
12	DCOUT12	Out	27	DCIN5	In	42	DCIN14	In
13	DCOUT13	Out	28	DCIN6	In	43	DCIN15	In
14	DCOUT14	Out	29	DCIN7	In	44	DCIN16	In
15	DCOUT15	Out	30	DCIN8	In		Drain (Shield)	
							Drain (Shield)	

### 21.1.5.2 Cable - GEN I/O Connector to Breakout Box

Figure 21-15: Cable for GEN I/O Connector to Breakout Box



The MMC Gen I/O connector cable at the MMC (female connection) is compatible with the MMC Aux I/O breakout box connector cable. Similarly, the MMC Aux I/O connector cable at the MMC (male connection) is compatible with the MMC Gen I/O breakout box connector cable. With this compatibility, the cables between the MMC Aux/Gen connectors and the Aux/

Gen breakout boxes are the same. To move a cable from one to the other, just swap the cable ends.

**Table 21-18: Pinout - Cable for GEN I/O Connector to Breakout Box**

Pin	Description	In/Out	Pin	Description	In/Out	Pin	Description	In/Out
1	DCOUT1	Out	16	DCOUT16	Out	31	NC	
2	DCOUT2	Out	17	NC		32	NC	
3	DCOUT3	Out	18	NC		33	NC	
4	DCOUT4	Out	19	NC		34	IO24V	Out
5	DCOUT5	Out	20	IO24V	Out	35	DCSS2	In
6	DCOUT6	Out	21	DCSS1	In	36	IO24C	Out
7	DCOUT7	Out	22	IO24C	Out	37	DCIN9	In
8	DCOUT8	Out	23	DCIN1	In	38	DCIN10	In
9	DCOUT9	Out	24	DCIN2	In	39	DCIN11	In
10	DCOUT10	Out	25	DCIN3	In	40	DCIN12	In
11	DCOUT11	Out	26	DCIN4	In	41	DCIN13	In
12	DCOUT12	Out	27	DCIN5	In	42	DCIN14	In
13	DCOUT13	Out	28	DCIN6	In	43	DCIN15	In
14	DCOUT14	Out	29	DCIN7	In	44	DCIN16	In
15	DCOUT15	Out	30	DCIN8	In	Shell	Drain (shield)	

## 21.2 Cables from Centurion Drives to MMC Axis Connector

### 21.2.1 Cable - DSM J1 Connector to MMC Axis Connector

**Table 21-19: Part No. - Cable from DSM J1 Connector to MMC or Axis I/O Option Module Connector**

(only for MMC Servo Control Axis Ports A1, A2, A3, A4)		
Description	Length	Part Number
MMC Axis A'n' to DSM J1 Connector	1'	M.1016.2516
MMC Axis A'n' to DSM J1 Connector	2'	M.1016.2517
MMC Axis A'n' to DSM J1 Connector	3'	M.1016.2518

**Figure 21-16: Cable from DSM J1 Connector to MMC Axis Connector**

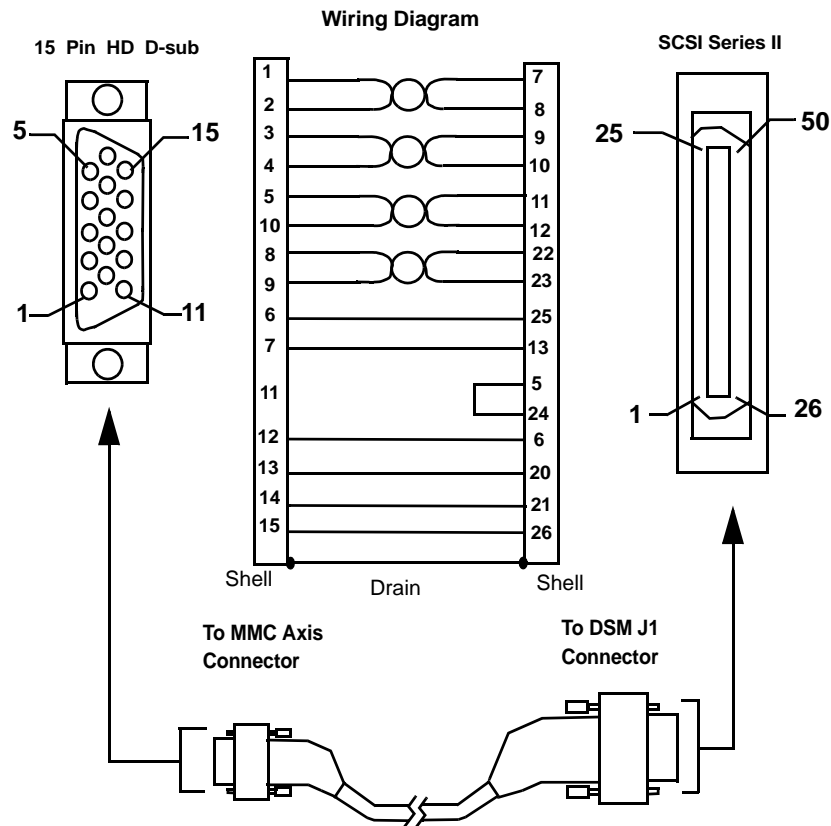

**Table 21-20: Pinouts - Cable from DSM J1 Connector to MMC or Axis I/O Option Module Connector**

15-Pin D-sub		SCSI Series II			
Pin	Description	Pin	Description	Pin	Description
1	A	1	Encoder +5VDC	26	Isolated +24VDC
2	A/	2	Encoder COM	27	+ I Limit
3	B	3	Encoder +5VDC	28	Analog COM
4	B/	4	Encoder COM	29	- I Limit
5	I	5	Isolated +24VDC	30	Analog Output 1
6	DCIN+	6	Isolated 24V COM	31	Analog Output 2
7	DCIN-	7	Mtr Output Chnl A+	32	Selectable Input 1
8	DA+	8	Mtr Output Chnl A-	33	Selectable Input 2
9	DA-	9	Mtr Output Chnl B+	34	Selectable Input 3
10	I/	10	Mtr Output Chnl B-	35	Selectable Input 4
11	+24 VDC out	11	Mtr Output Chnl I+	36	RSVD
12	COM	12	Mtr Output Chnl I-	37	RSVD
13	DCOUT1	13	Isolated 24V COM	38	RSVD
14	DCOUT2	14	Auxiliary Chnl A+	39	RSVD
15	DCOSS	15	Auxiliary Chnl A-	40	RSVD
Shell	Drain (shield)	16	Auxiliary Chnl B+	41	RSVD
		17	Auxiliary Chnl B-	42	Selectable Output 1
		18	Auxiliary Chnl I+	43	Selectable Output 2
		19	Auxiliary Chnl I-	44	Selectable Output 3
		20	Drive Enable	45	Selectable Output 4
		21	Fault Reset	46	RSVD
		22	Analog Cmnd +	47	RSVD
		23	Analog Cmnd -	48	RSVD
		24	Drive Ready +	49	Brake Enable +
		25	Drive Ready -	50	Brake Enable -
				Shell	Drain (shield)

### 21.2.2 Cable - MicroDSM J1 to MMC Axis Connector

**Table 21-21: Part No. - Cable from MicroDSM J1 Connector to MMC or Axis I/O Option Module Connector**

(only for MMC Servo Control Axis Ports A1, A2, A3, A4)		
Description	Length	Part Number
MMC Axis A"n" to MicroDSM J1 Connector	1'	M.1016.2512
MMC Axis A"n" to MicroDSM J1 Connector	2'	M.1016.2513
MMC Axis A"n" to MicroDSM J1 Connector	3'	M.1016.2514

**Figure 21-17: Cable from MicroDSM J1 Connector to MMC or Axis I/O Option Module Connector**

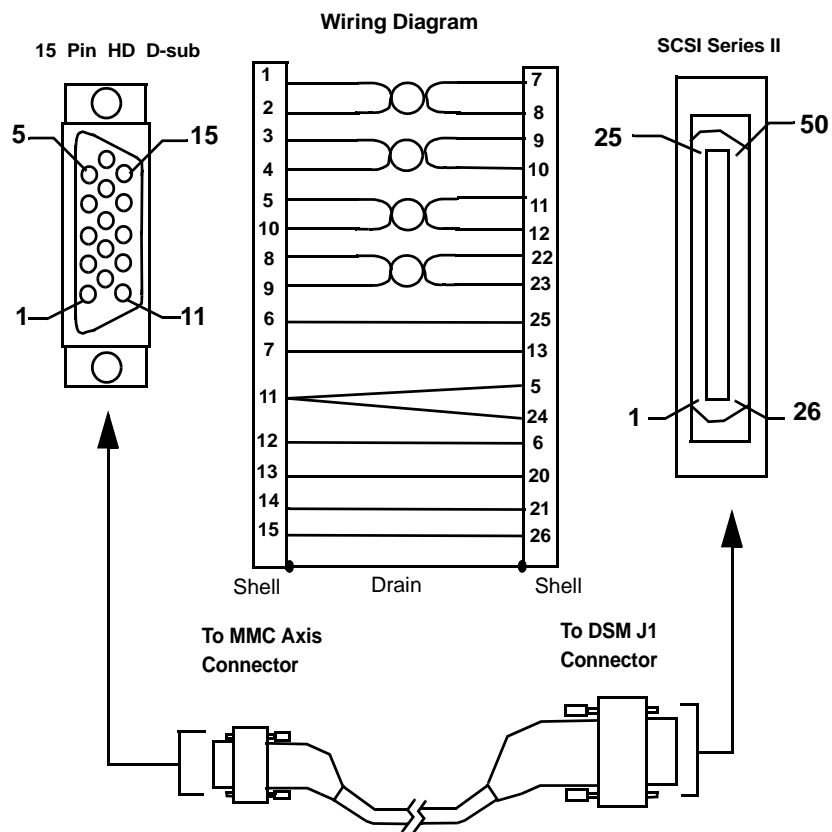



**Table 21-22: Pinouts - Cable from MicroDSM J1 Connector to MMC or Axis I/O Option Module Connector**

15-Pin D-sub		SCSI Series II			
Pin	Description	Pin	Description	Pin	Description
1	A	1	Encoder +5VDC	26	External I/O Power
2	A/	2	Encoder 5V COM	27	I Limit
3	B	3	Encoder +5VDC	28	Analog COM
4	B/	4	Encoder 5V COM	29	Reserved
5	I	5	External I/O Power	30	Reserved
6	DCIN+	6	External I/O Com	31	Analog Output 1
7	DCIN-	7	Mtr Output Chnl A+	32	Selectable Input 1
8	DA+	8	Mtr Output Chnl A-	33	Selectable Input 2
9	DA-	9	Mtr Output Chnl B+	34	Selectable Input 3
10	I/	10	Mtr Output Chnl B-	35	Reserved
11	+24 VDC out	11	Mtr Output Chnl I+	36	Reserved
12	COM	12	Mtr Output Chnl I-	37	Reserved
13	DCOUT1	13	Exteranl I/O COM	38	Reserved
14	DCOUT2	14	Auxiliary Chnl A+	39	Reserved
15	DCOSS	15	Auxiliary Chnl A-	40	Reserved
Shell	Drain (shield)	16	Auxiliary Chnl B+	41	Reserved
		17	Auxiliary Chnl B-	42	Selectable Output 1
		18	Auxiliary Chnl I+	43	Selectable Output 2
		19	Auxiliary Chnl I-	44	Reserved
		20	Drive Enable	45	Reserved
		21	Fault Reset	46	Reserved
		22	Analog Cmnd +	47	Reserved
		23	Analog Cmnd -	48	Reserved
		24	Drive Ready +	49	Brake Enable +
		25	Drive Ready -	50	Brake Enable -
				Shell	Drain (shield)

## 21.3 Flying Lead Cables to MMC Control or Axis I/O Option Module

### 21.3.1 Flying Lead Cable to MMC or Axis I/O Option Module Connector

Table 21-23: Part No. - Flying Lead Cable to MMC or Axis I/O Option Module Connector

(for MMC Servo Control Axis Ports A1, A2, A3, A4)		
Description	Length	Part Number
MMC Axis A"n" to Flying Lead Cable	10'	M.1016.2519

Figure 21-18: Flying Lead Cable to MMC or Axis I/O Option Module Connector

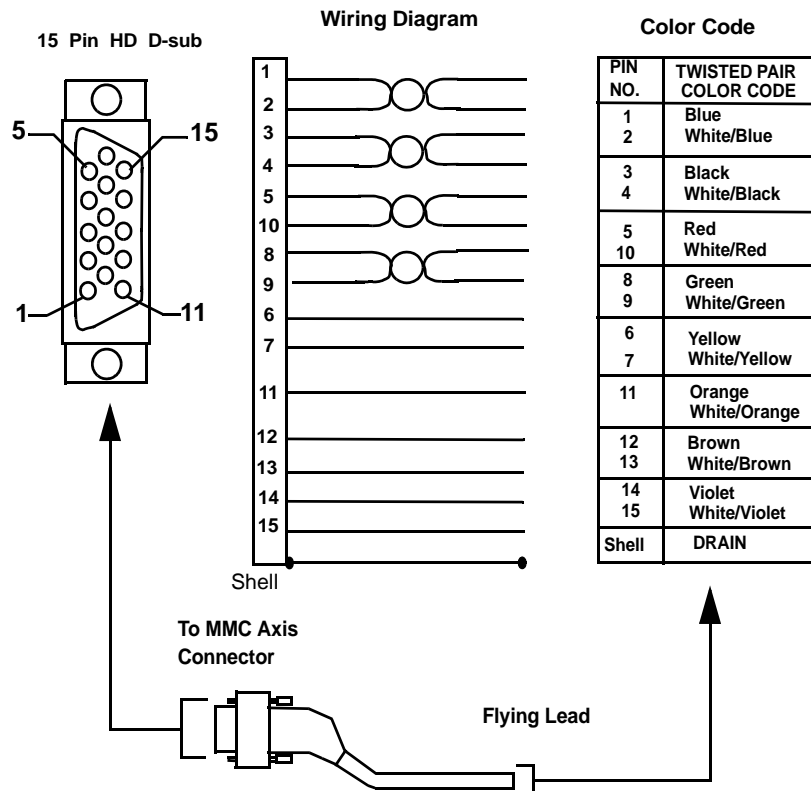

Table 21-24: Pinout - Flying Lead Cable to MMC Axis Connector

Pin	Description	Pin	Description	Pin	Description	Pin	Description
1	A	6	DCIN+	11	+24 VDC	Shell	Drain (shield)
2	A/	7	DCIN-	12	COM		
3	B	8	DA+	13	DCOUT1		
4	B/	9	DA-	14	DCOUT2		
5	I	10	I/	15	DCOSS		

### 21.3.2 Flying Lead Cable to MMC or Axis I/O Option Module AUX I/O Connector

**Table 21-25: Part No. - Flying Lead Cable to MMC or Axis I/O Option Module AUX I/O Connector**

Description	Length	Part Number
MMC AUX I/O Connector to Flying Lead Cable	10'	M.1016.2566

**Figure 21-19: Flying Lead Cable to MMC or Axis I/O Option Module AUX I/O Connector**

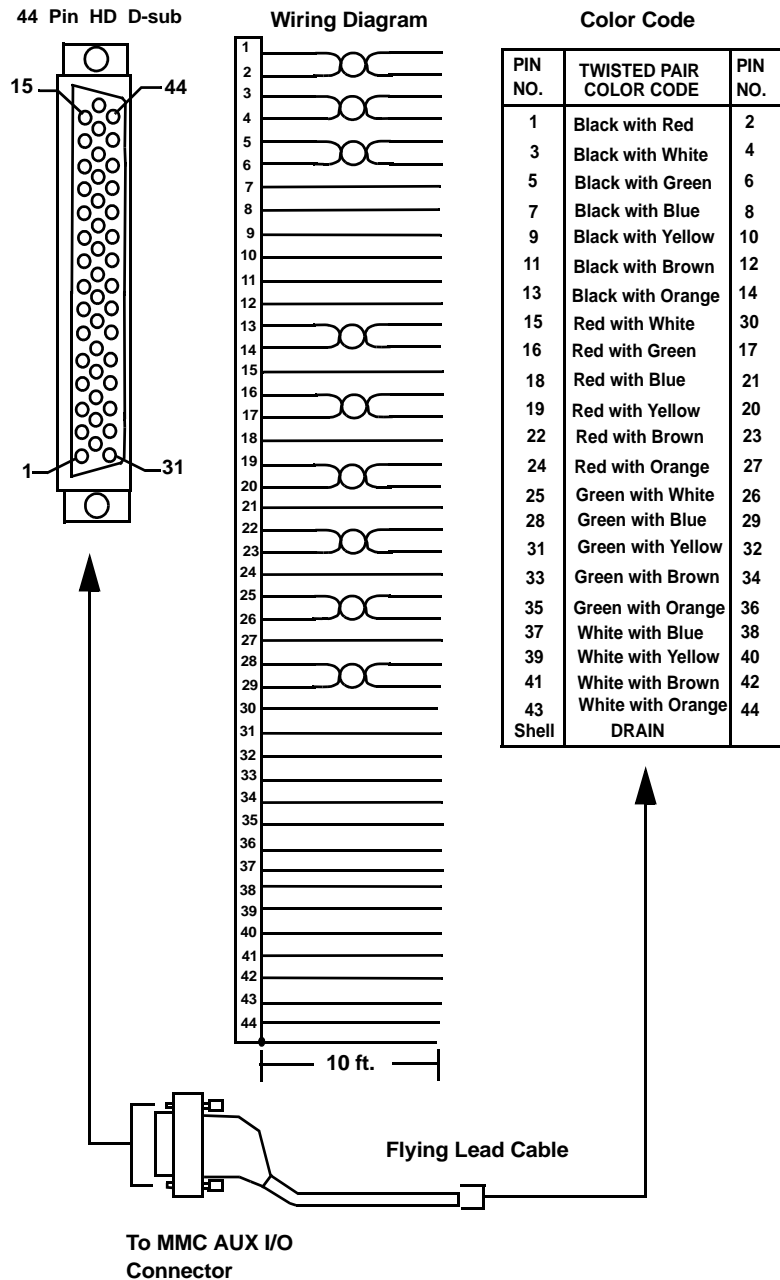

**Table 21-26: Pinout - Flying Lead Cable to MMC-A4 or Axis I/O Option Module AUX I/O Connector**

Pin	Description	Pin	Description	Pin	Description
1	A	16	FASTIN1+	31	DCSSA
2	A/	17	FASTIN1-	32	DCIN1
3	B	18	SHIELD	33	DCIN2
4	B/	19	FASTIN2+	34	DCIN3
5	I	20	FASTIN2-	35	DCIN4
6	I/	21	SHIELD	36	DCIN5
7	SHIELD	22	FASTIN3+	37	DCIN6
8	+24 VDC out	23	FASTIN3-	38	DCSSB
9	+24 VDC out	24	SHIELD	39	DCIN7
10	COM	25	FASTIN4+	40	DCIN8
11	COM	26	FASTIN4-	41	DCIN9
12	+5 VDC out	27	SHIELD	42	DCIN10
13	ANLGIN+	28	FASTIN5+	43	DCIN11
14	ANLGIN-	29	FASTIN5-	44	DCIN12
15	SHIELD	30	SHIELD	Shell	Drain (shield)

**Table 21-27: Pinout - Flying Lead Cable to MMC-A2 AUX I/O Connector**

Pin	Description	Pin	Description	Pin	Description
1	A	16	FASTIN1+	31	DCSSA
2	A/	17	FASTIN1-	32	DCIN1
3	B	18	SHIELD	33	DCIN2
4	B/	19	FASTIN2+	34	DCIN3
5	I	20	FASTIN2-	35	DCIN4
6	I/	21	SHIELD	36	DCIN5
7	SHIELD	22	NC	37	DCIN6
8	+24 VDC out	23	NC	38	NC
9	+24 VDC out	24	SHIELD	39	NC
10	COM	25	NC	40	NC
11	COM	26	NC	41	NC
12	+5 VDC out	27	SHIELD	42	NC
13	ANLGIN+	28	FASTIN5+	43	NC
14	ANLGIN-	29	FASTIN5-	44	NC
15	SHIELD	30	SHIELD	Shell	Drain (shield)

### 21.3.3 Flying Lead Cable to MMC BLK I/O Connector

**Table 21-28: Part No. - Flying Lead Cable to MMC BLK I/O Connector**

Description	Length	Part Number
MMC BLK I/O Connector to Flying Lead Cable	10'	M.1016.2568

**Figure 21-20: Flying Lead Cable to MMC BLK I/O Connector**

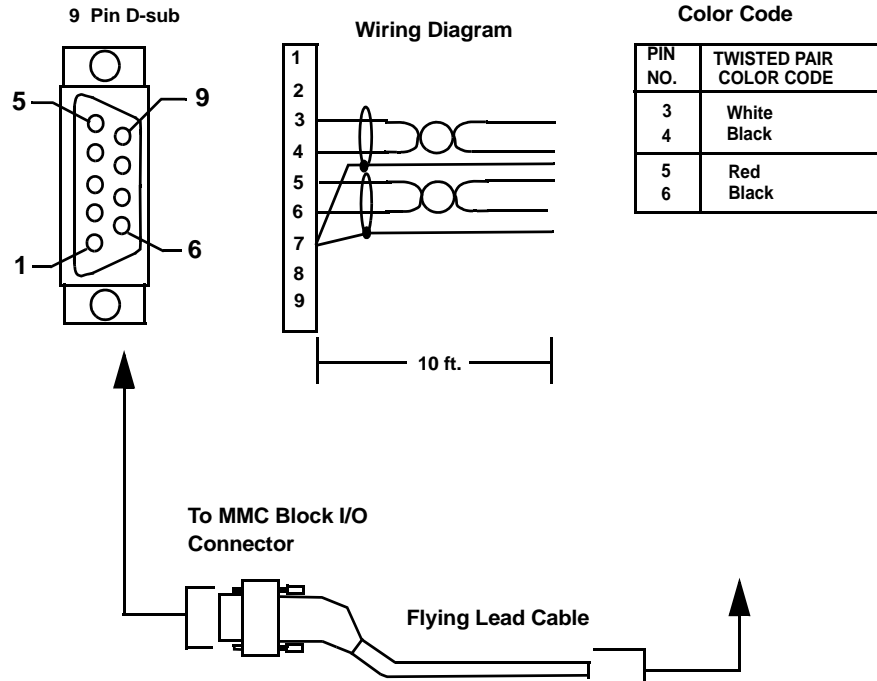

**Table 21-29: Pinout - Flying Lead Cable to Block I/O Connector**

Pin	Desc.	In/Out	Pin	Desc.	In/Out	Pin	Desc.	Pin
1	NC		4	Block I/O Transmit Data -	Out	7	Shield	
2	NC		5	Block I/O Receive Data +	In	8	NC	
3	Block I/O Transmit Data +	Out	6	Block I/O Receive Data -	In	9	NC	

### 21.3.4 Flying Lead Cable to MMC USER PORT Connector

**Table 21-30: Part No. - Flying Lead Cable to MMC USER PORT Connector**

Description	Length	Part Number
MMC USER PORT Connector to Flying Lead Cable	10'	M.1016.2565

**Figure 21-21: Flying Lead Cable to USER PORT Connector**

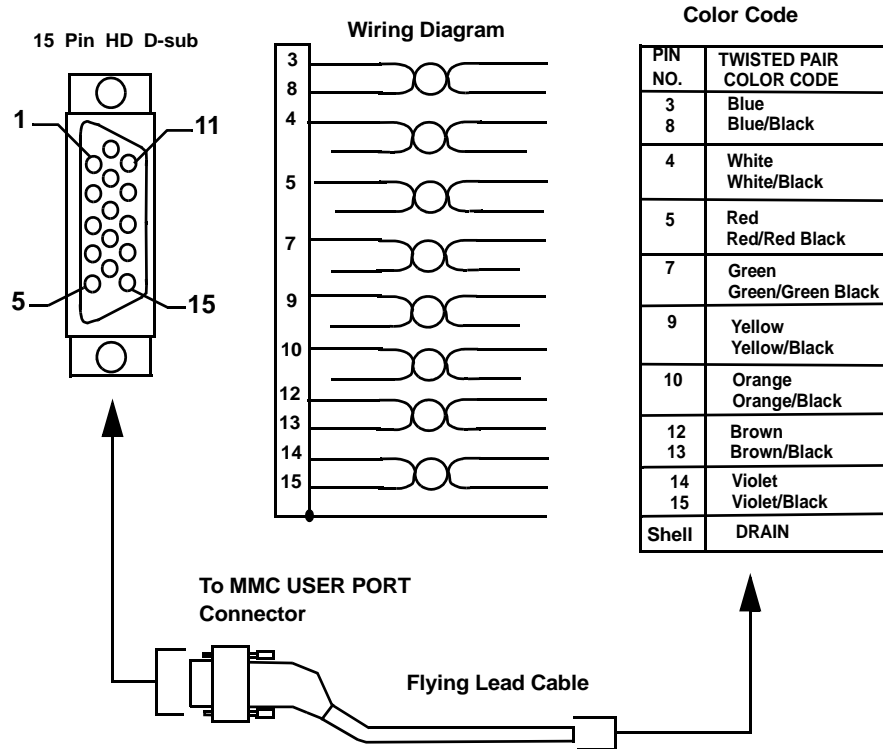

**Table 21-31: Pinout - Flying Lead Cable to MMC USER PORT Connector**

Pin	Description	In/Out	Pin	Description	In/.Out
1	NC		9	RS232 Receive Data	In
2	NC		10	RS232 Transmit Data	Out
3	+5V (50mA Max)	Out	11	NC	
4	RS232 Data Terminal Ready	Out	12	RS485 Receive Data +	In
5	RS232 Request to Send	Out	13	RS485 Receive Data -	In
6	NC		14	RS485 Transmit Data +	Out
7	RS232 Clear to Send	In	15	RS485 Transmit Data -	Out
8	Signal Ground	In/Out	Shell	Drain (shield)	

### 21.3.5 Flying Lead Cable to MMC GEN I/O Connector

Table 21-32: Part No. - Flying Lead Cable to MMC GEN I/O Connector

Description	Length	Part Number
MMC GEN I/O Connector to Flying Lead Cable	10'	M.1016.2567

Figure 21-22: Flying Lead Cable to GEN I/O Connector

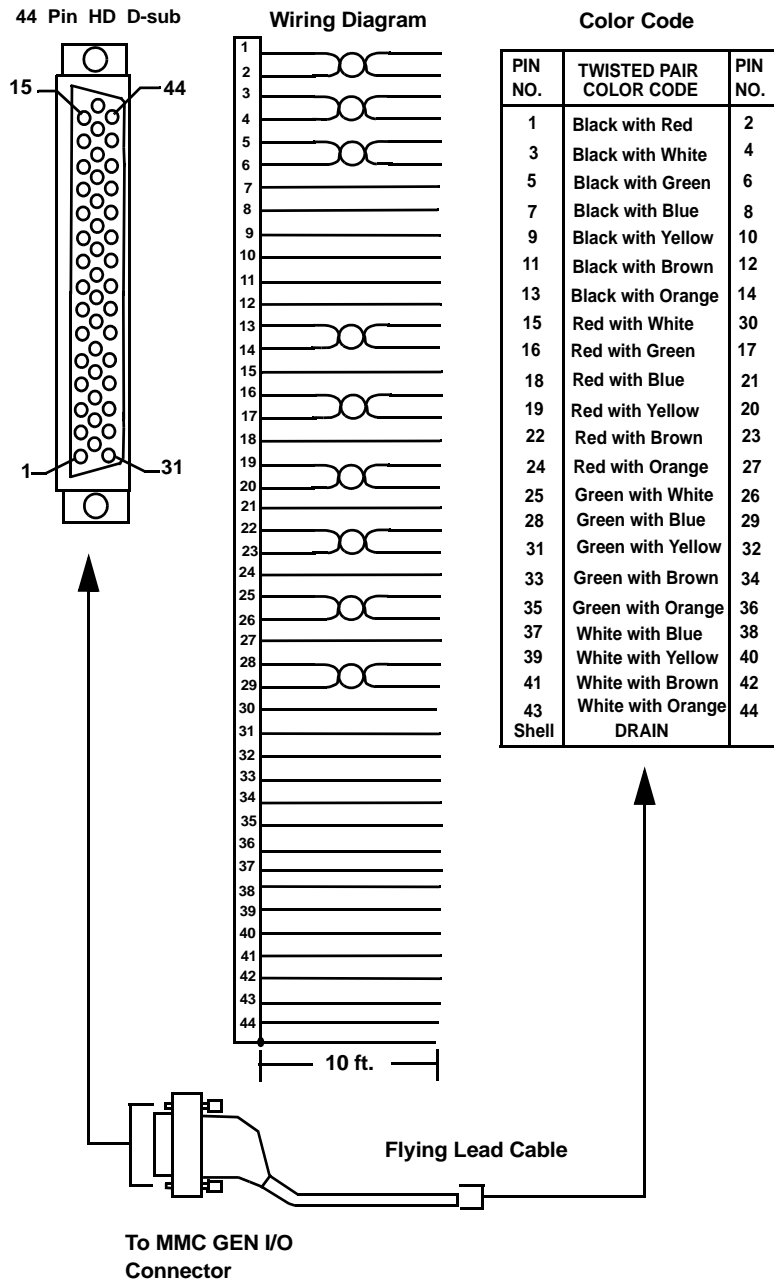



**Table 21-33: Pinout - Flying Lead Cable to MMC GEN I/O Connector**

Pin	Description	In/Out	Pin	Description	In/Out	Pin	Description	In/Out
1	DCOUT1	Out	16	DCOUT16	Out	31	NC	
2	DCOUT2	Out	17	NC		32	NC	
3	DCOUT3	Out	18	NC		33	NC	
4	DCOUT4	Out	19	NC		34	IO24V	Out
5	DCOUT5	Out	20	IO24V	Out	35	DCSS2	In
6	DCOUT6	Out	21	DCSS1	In	36	IO24C	Out
7	DCOUT7	Out	22	IO24C	Out	37	DCIN9	In
8	DCOUT8	Out	23	DCIN1	In	38	DCIN10	In
9	DCOUT9	Out	24	DCIN2	In	39	DCIN11	In
10	DCOUT10	Out	25	DCIN3	In	40	DCIN12	In
11	DCOUT11	Out	26	DCIN4	In	41	DCIN13	In
12	DCOUT12	Out	27	DCIN5	In	42	DCIN14	In
13	DCOUT13	Out	28	DCIN6	In	43	DCIN15	In
14	DCOUT14	Out	29	DCIN7	In	44	DCIN16	In
15	DCOUT15	Out	30	DCIN8	In	Shell	Drain (shield)	

**NOTES**

---

---

## 22 CE and EMC Guidelines

---

NOTE
The CE mark on PiC products assures compliance with both the EMC and low voltage European directives. Prior to this CE mark, EMC on the product label only assured compliance with the EMC directives.

### 22.1 Background on EMC (Electromagnetic Compatibility) Compliance

In order to market products in the European Union after January 1, 1996, an electromagnetic compatibility directive (EU Directive 89/336/ECC) must be met. All products must be designed and manufactured in such a way that:

1. Electromagnetic disturbances generated by the products do not cause interference to other systems.
2. The performance of the product is not affected by electromagnetic disturbances within the environment in which the product is intended to operate.

The directive refers to relevant harmonized European EMC standards against which product conformity can be assessed, although other methods of assessment, notably the preparation of a Technical File, are permissible. The equipment manufacturer or the manufacturer's agent in the Community must make a Declaration of Conformity and can place the CE mark on the product. Failure to conform with the requirements of the directive can result in a total ban on sales throughout the Single Market and legal action could be taken against the signatory of a false declaration of conformity.

### 22.2 Background on Low Voltage Compliance

In order to market products in the European Union after January 1, 1997, the low voltage directive (EU Directive 73/23/EEC) must be met.

The intention of the directive is to assure user safety under normal operating and fault conditions. The directive includes the use of certain warning labels and user instructions. It establishes limits to prevent electrical shock hazard, overheating and fire.

## 22.3 RFI Emission and Immunity

The EMC product characteristics are classified by the emission and immunity performance.

Emissions not only include radiated noise from the product enclosure and cabling, but also that which is conducted away from the product along the cables connected to it. This may be subsequently radiated from the cable or conducted directly into another product which shares this cable e.g. the main AC supply.

Immunity is how susceptible a product is (e.g. to the radiated and conducted emissions from the product mounted next to it). To ensure compatibility, the immunity of a product must always exceed the expected emissions in the environment in which it operates as is shown in the diagram below. This is to ensure a margin of safety.

**Figure 22-1: Safety Margin**

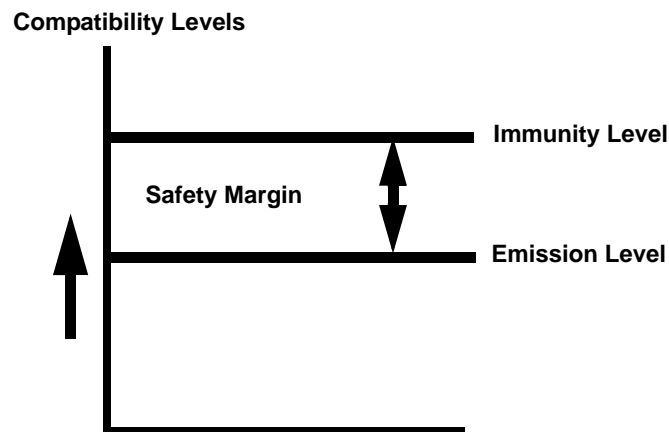

In addition to conducted and radiated immunity, products must also be capable of withstanding:

1. Electro-static discharges (ESD)
2. Conducted fast transient voltages

The discharge spark generated from ESD can easily damage electronic components. The conducted fast transient voltages are induced in cables laid in close proximity to other cables in which large inductive loads are switched (such as relays, contactors, and AC motor starters). This is a good example of what can happen to sensitive control and signal cabling connected to drives when poorly installed in enclosures on industrial sites.

## **22.4 Classes of EMC Operating Environments**

Before the correct level of EMC can be designed into equipment, the EMC operating environment must be defined. For example in industrial locations where high power equipment is in use, high levels of background electrical noise would be expected when compared to a household or office environment. Since it is more expensive to reduce the emissions from higher power equipment than to increase the immunity, the emission limits allowed in industrial environments are higher than for household or office environments. Vice versa for immunity because of the higher emission limits in industrial environments, the immunity requirements are more strict than for the household or office environment. Hence in order to achieve EMC between different equipment, it is essential to know what EMC operating environment it is to be installed in, and to compare the installation environment to the environment for which it was designed.

Today using generic EMC standards, two environments are defined:

1. Industrial
2. Residential, commercial, and light industrial

The environments are locations defined on the basis of whether the AC supply is shared with other locations or is buffered from them with a distribution transformer. If your location is buffered via a distribution transformer, then you are in an industrial environment. If you share your AC supply with a neighboring location, then you are in a residential, commercial, or light industrial environment. For example, an industrial unit which shares its AC supply with a neighboring unit is defined as a residential, commercial, and light industrial location. If it is supplied from its own distribution transformer, then it is an industrial location.

## 22.5 Conformance with the EMC Directive

G&L Motion Control will be complying to the Directive by self-certification to the following generic EMC standards:

1. EN50081-2 for industrial emissions using EN55011 (based upon CISPR 11A)
2. EN50082-2 for industrial immunity using:
  - IEC 61000-4-2 (ESD- 4KV contact mode, 8 KV air discharge)
  - IEC 61000-4-3 (Radiated susceptibility)
  - IEC 61000-4-4 (Electrical fast transient)
  - IEC 6100-4-8 (Magnetic fields)

A statement of compliance will be made with the letters "EMC" or "CE" on the product, but will be valid only if the product is installed properly.

## 22.6 Conformance With the Low Voltage Directive

G&L Motion Control will comply with the Directive by self certification to the following standard:

EN 61131-2:1994/A11:1996 Low Voltage Requirements for Programmable Controllers

A statement of compliance will be made with the letters "CE" on the product but will be valid only if the equipment is properly installed.

## 22.7 Changes to the PiC Products

G&L Motion Control PiC products had originally been designed with a high level of noise immunity and tested according to standards such as NEMA showering arc and the original version of IEC 801-2. However, the EU directive for immunity requires testing to standards that have more variables and are more repeatable. The directive also requires control of emissions, something that is not regulated in U. S. industrial environments.

As a result, changes have been made to the hardware modules within the PiC product line. The changes have included the addition of filtering, re-routing of foils and/or the addition of ground planes to printed circuit boards, use of some conductive enclosures, provision for shielded wires\* for peer-to-peer communication, and internal connection of SPG to field side connectors.

### \*NOTE

A recommended shielded wire is Belden, 24 AWG (7X32), 9729

## 22.7.1 Changes Affecting the User

Many of the changes G&L Motion Control has implemented are transparent to the user. However, there are some changes affecting user installation.

G&L Motion Control continues to recommend separation of low level signals (encoder, analog, communications, fast DC inputs) from high voltage or high current lines from any of the above. More specifically, maintain *at least* one inch of separation around encoder signals and around communication signals.

It is no longer necessary to connect a wire from a module to SPG. This user-installed wire had been a source of emissions and thus the connection should not be made. Analog modules typically had this requirement in the past.

To prevent excessive conducted emissions from a DC power source (typically 24V) used for digital I/O, a 1000 picofarad capacitor should be used. Connect the capacitor from the +24V DC to COMMON at the distribution terminals. The same applies to any other external DC power source used with the PiC product.

The figure on the left below illustrates the connection method *before* EMC compliant products were available. The figure on the right illustrates the recommended connections when using EMC compliant products. On the right, note that the SPG connection has been eliminated and that a capacitor is connected to the 24V DC supply.

**Figure 22-2: Connections for EMC Compliance**

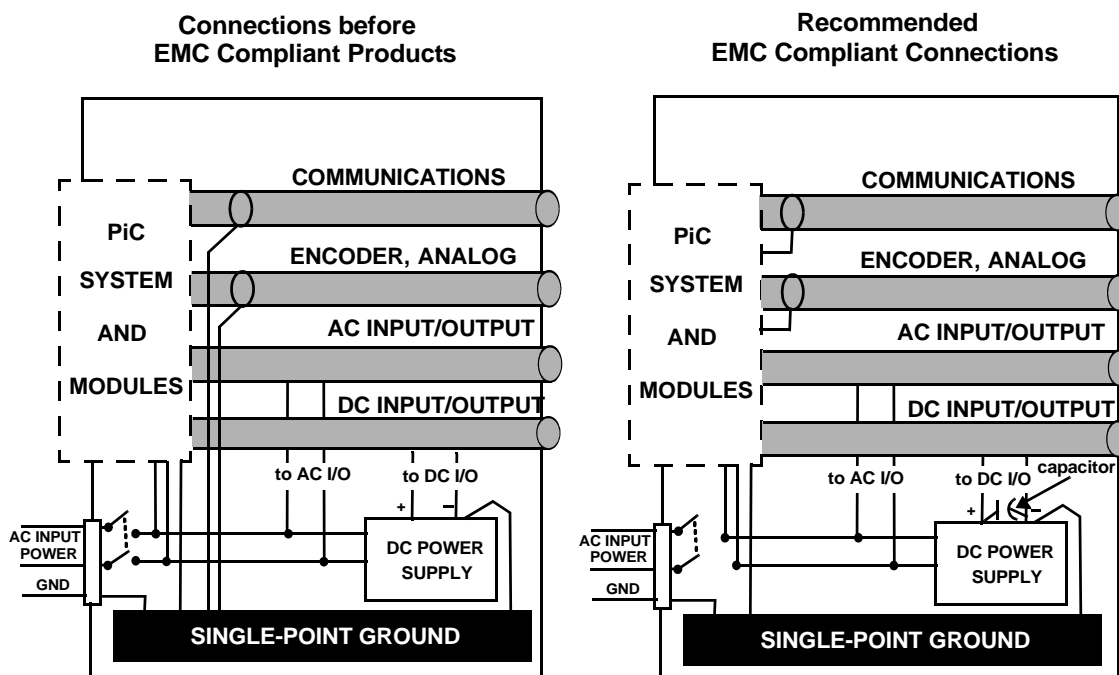

There is now a provision for shield termination to the CPU modules for peer-to-peer communication. Shielded cable must be used to reduce emissions.

Inside a control cabinet, the practice of connecting the shields of shielded cables at the modules should be continued. For an example of a shielded cable entering/leaving the cabinet see Figure 22-3 on page 150.

**Figure 22-3: Connecting Shielded Cable**

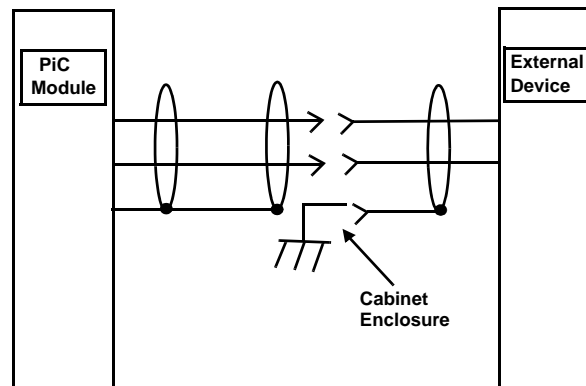

The two different methods of terminating shields are used to accommodate two different immunity requirements. Immunity required inside an enclosure is considered lower because cables are typically less than 3 meters in length and/or can be separated from each other and from noise sources.

Immunity required external to an enclosure is considered higher because the user may have less control over the noise environment. Low level signal cables that can be external to an enclosure and AC/DC digital I/O cables have been tested at a 2 KV level for electrical fast transients (EFTs). Low level signals that can be less than 3 meters in length or can be separated from noise sources are tested at a 1 KV level.



Under the stated conditions, there will be no disturbance of digital I/O, encoder, or stepper operation. For analog signals, there may be momentary disturbances but there will be self-recovery when the noise subsides.

In order to meet the EU directive requirement for emissions and immunity, fiber optics must be used for I/O expansion.

Although the control will pass the electrical fast transient test on incoming power lines, users may still want to use a power line conditioner.

As a general precaution, do not operate transmitters, arc welding equipment, or other high noise radiators within one meter of a PiC enclosure that has the door open. Continue to equip inductive devices, if they are in series with a mechanical contact or switch, with arc suppression circuits. These devices include contactors, solenoids and motors. Shield all cables that carry heavy current near the system, using continuous foil wrap or conduit grounded at both ends. Such cables include power leads for high-frequency welders and for pulse-width-modulated motor drives.

**NOTE**

Shields for signal wires are grounded at only one end, to provide immunity to outside noise sources. However, the shields for "noise sources" are grounded at both ends, to reduce emissions and "contain" the noise.

Worst case tests with analog I/O modules have caused momentary disturbances no greater than .5V in a +10V to -10V range and .5 mA in a 4 to 20 mA range. Worst case tests with an RTD module have caused momentary disturbances no greater than + or -4°C in a range of -200° to 266°C. Worst case tests with a JK thermocouple module have caused momentary disturbances no greater than + or - 1 mV over a 100 to 1.

**NOTE**

To assure compliance with the low voltage directive, it is necessary to follow installation instructions in the controller Hardware Manual. Also refer to any instructions specific to individual control modules.

## 22.8 Using CE/EMC and Non-CE/EMC Modules

### IMPORTANT

Failure to follow these guidelines may result in undesired system performance.

### NOTE

CE indicates compliance to both the EMC and low voltage directives.  
EMC indicates compliance to the EMC directive.

There are several issues that must be considered when using CE/EMC compliant and Non-CE/EMC compliant Modules. This document addresses these issues.

**Module Identification** - To determine whether a module is CE/EMC or Non-CE/EMC, look at the gray Unit Tag located on the side of the plastic module case. CE/EMC modules will have “CE” or “EMC” printed near the “MAX. AMBIENT TEMP.” specification. Non-CE/EMC will not have “CE” or “EMC” printed in this location.

**Grounding** - Due to differences in shielding requirements, it is extremely important to follow proper shielding guidelines for a given module. Failure to do so may result in intermittent operation in noisy environments.

For modules that have an SPG terminal and/or one or more SHIELD terminal, perform the following:

- For CE/EMC modules, do not connect the SPG terminal or SHIELD terminals to the system’s Single Point Ground
- For Non-CE/EMC modules, connect the SPG terminal, or a SHIELD terminal, to the system’s Single Point Ground

**CE/EMC CSM and RSM Modules** - Using a CE/EMC CSM, RSM, or CSM/CPU (PiC90) with certain Non-CE/EMC analog modules may cause intermittent operation. Follow these guidelines for determining the type of CSM, RSM, or CSM/CPU that should be used in a particular rack:

- If your rack contains one or more Non-CE/EMC modules that perform D/A conversion or provide an Encoder interface, you must use a non-CE/EMC CSM, RSM, or CSM/CPU (PiC90).

- If your rack contains one or more Non-CE/EMC modules that perform D/A conversion or provide an Encoder interface, you must use a non-CE/EMC CSM, RSM, or CSM/CPU (PiC90).
- If your rack does not contain one or more Non-CE/EMC modules that perform D/A conversion or provide an Encoder interface, you may use either a CE/EMC or Non-CE/EMC CSM, RSM, or CSM/CPU (PiC90).

**NOTE**

For a system to be CE/EMC compliant, all modules and backplanes must be CE/EMC compliant

## 22.9 Declarations of Conformity

The undersigned, representing the supplier

**G & L Motion Control Inc.**  
**672 South Military Road**  
**Fond du Lac, Wisconsin 54936-1960**

herewith declares that all **PiC900™/PiC90™/PiC9™/MMC and Block I/O modules**, labeled with the CE mark, are in conformity with the provisions of the following EC Directives when installed in accordance with the installation instructions contained in the product documentation:

*Low Voltage Directive 73/23/EEC as amended by 93/68/EEC*  
*EMC Directive 89/336/EEC as amended by 92/31/EEC and 93/68/EEC*

Conformity of the specified product is based upon application of the following standards and/or technical specifications referenced below:

<i>EN 50081-2:1993</i>	<i>EMC Generic Industrial Emissions</i>
<i>EN 50082-2:1995</i>	<i>EMC Generic Industrial Immunity</i>
<i>EN 61131-2:1994/A11:1996</i>	<i>Low voltage requirements for programmable controllers</i>
<i>EN61326:1997</i>	<i>Electrical Equipment for measurement, control and Laboratory use – EMC requirements</i>

Year of Marking: 2002

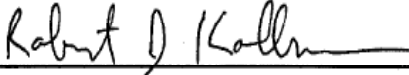
Signature	
Full Name	Robert J. Kollmeyer
Position	Director of Engineering
Place	G & L Motion Control Inc.
Date	05-APR-05

## EC DECLARATION OF CONFORMITY

The undersigned, representing the supplier

**G & L Motion Control Inc.**  
**672 South Military Road**  
**Fond du Lac, Wisconsin 54936-1960**

herewith declares that all **three-phase current synchronous motors, type MSM** are in conformity with the provisions of the following EC Directive when installed in accordance with the installation instructions contained in the product documentation:

*Low Voltage Directive 73/23 EWG*

Conformity of the specified product with the guidelines of this directive will be proved by the total compliance with the following harmonic European standards:

*EN 60034-1: November 1995      Rotating Electrical Machines*  
*EN 60034-5: April 1998*  
*EN 60034-9: May 1996*

Year of Marking: 1999

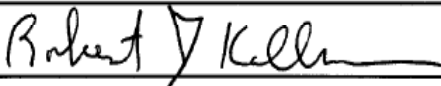
Signature	
Full Name	Robert J. Kollmeyer
Position	Director of Engineering
Place	G & L Motion Control Inc.
Date	05 - APR - 05

## EC DECLARATION OF CONFORMITY

The undersigned, representing the supplier

**G & L Motion Control Inc.**  
**672 South Military Road**  
**Fond du Lac, Wisconsin 54936-1960**

herewith declares that all **three-phase current synchronous motors, type LSM** are in conformity with the provisions of the following EC Directive when installed in accordance with the installation instructions contained in the product documentation:

*Low Voltage Directive 73/23 EWG*

Conformity of the specified product with the guidelines of this directive will be proved by the total compliance with the following harmonic European standards:

*EN 60034-1: September 2000      Rotating Electrical Machines*  
*+A11 May 2002*  
*EN 60034-5: December 2001*  
*EN 60034-9: June 1998*

Year of Marking: 2002

<i>Signature</i>	<i>Robert J. Kollmeyer</i>
<i>Full Name</i>	Robert J. Kollmeyer
<i>Position</i>	Director of Engineering
<i>Place</i>	G & L Motion Control Inc.
<i>Date</i>	<i>05-APR-05</i>

## EC DECLARATION OF CONFORMITY

The undersigned, representing the supplier

**G & L Motion Control Inc.**  
**672 South Military Road**  
**Fond du Lac, Wisconsin 54936-1960**

herewith declares that all **MMC Smart Drives (MMC-SD-XXX-230-XXX, MMC-SD-XXX-460-XXX) and accessories** are in conformity with the provisions of the following EC Directive(s) when installed in accordance with the installation instructions contained in the product documentation:

73/23/EEC  
89/336/EEC

*Low Voltage Directive as amended by 93/68/EEC*  
*EMC Directive as amended by 92/31/EEC and 93/68/EEC*

and that the standards and/or technical specifications referenced below have been applied:

EN 50178:1998  
EN 61800-3:1996  
/A11:2000

*Electronic equipment for use in power installations*  
*Adjustable speed electrical power drive systems – EMC*  
*product standard including specific test methods*

Year of Marking: 2003

Signature	<i>Robert J. Kollmeyer</i>
Full Name	Robert J. Kollmeyer
Position	Director of Engineering
Place	G & L Motion Control Inc.
Date	<i>05-APR-05</i>





# **Index**

## **Numerics**

10Base T connection 83  
24-bit latch 67, 103  
24-bit up/down counter 67, 103

## **A**

analog input  
    theory of operation 68, 104  
analog output  
    theory of operation 65, 69, 101  
analog output to drive connections 47  
analog servo module 9  
application  
    in flash 60  
    wiring 27  
auxiliary I/O  
    connector 49  
        general purpose inputs 52  
    pinout 49  
available I/O 9, 10  
axis connectors  
    pinout 43  
axis DC input to drive ready connection 47

## **B**

battery  
    disposal 74  
    LED 57  
    position 73  
    replacement 72  
    type 74  
block I/O  
    port  
        pinout 36  
breakout box 35  
breakout box and cables  
    Auxiliary I/O 113  
    Auxiliary I/O with encoder isolators 116  
    Axis connector 110  
    block I/O 122  
    GEN I/O connector 128  
    User port 125

## **C**

cables 35  
centurion drive cable  
    DSM J1 connector to MMC Axis connec-

tor 132  
MicroDSM J1 to MMC Axis connector  
    134  
codes  
    diagnostic error 58  
communications  
    DeviceNet 89  
    Ethernet-TCP/IP 81  
    Profibus 95  
configuration  
    sink 45  
    source 45  
configuration port 92, 98  
configuration port LEDs  
    LEDs 98  
connection  
    10BaseT 83  
connection selector sheet  
    mmc analog control 107  
    MMC SERCOS control 108  
connections  
    analog output to drive 47  
    axis DC input to drive 47  
    DeviceNet 90  
    EMC 149  
    encoder inputs to drive encoder output 48  
    Ethernet-TCP/IP 82  
    fast inputs 51  
    general outputs 39  
    general purpose inputs 40  
    MMC analog servo module 43, 54  
    MMC CPU module 35  
    Profibus 96  
connector  
    auxiliary I/O 49  
    axis 43  
    block I/O 36  
    general I/O 38  
    PiCPro 35  
    power 41  
    user port 37  
control cabinet  
    requirements 19  
    specifications 19  
CPU 9  
current  
    leakage 64

## D

- DC input
    - theory of operation 63
  - DeviceNet 89
    - baud rates 93, 99
    - configuration software 93, 99
    - connections 90
    - LEDs 92
    - port 91, 97
    - proximity switch 93
    - specifications 94
    - theory of operation 93
  - diagnostic
    - error codes 58
    - LED 33, 57
    - power-on 33
    - run-time 34
    - troubleshooting 33
  - Diagnostics 33
  - differential devices 29
  - dimensions
    - mounting 13, 17
  - directive
    - EMC 145
  - distribution
    - power 21
  - download hex 31, 60
- ## E
- electrical service & maintenance safety 5
  - electromagnetic compatibility 145
  - electro-static discharge 146
  - EMC 145
    - conformance 148
    - directive 145
    - operating environments 147
    - PiC products 148
    - using EMC and Non-EMC modules 152
  - EMC connections 149
  - EMC Guidelines 145
  - encoder
    - error detection 29
    - quadrature 9, 66, 102
    - theory of operation 66, 102
  - encoder inputs to drive encoder output connections 48

- environment requirements
  - system 19
- error codes
  - diagnostic 58
- ESD 146
- ethernet
  - RS232 ports 84
- Ethernet-TCP/IP 81
  - connections 82
  - internet links 88
  - LEDs 85
  - specifications 87
  - specifications (IEEE 802.3) 82
  - theory of operation 86

## F

- fast input 67, 103
  - characteristics 67, 103
  - connection 51
  - sink configuration 51
  - source configuration 51
- fast transient voltage 146
- faults
  - diagnostic 58
- firmware
  - MMC Ethernet module 85
- flash memory 74
- flying lead cables
  - flying lead cable to MMC USER PORT connector 141
  - flying lead to MMC AUX I/O connector 137
  - flying lead to MMC Axis connector 136
  - flying lead to MMC BLK I/O connector 140
  - flying lead to MMC GEN I/O connector 142

## G

- general I/O
  - port pinout 38
- general inputs
  - sinking/sourcing 40
- general outputs
  - connections 39
- general purpose inputs

- connections 40
- grounding
  - protective earth 2
  - system 24

## H

- heat control
  - MMC system 25
- hex
  - download 31, 60

## I

- I/O 9, 10
- IEC 63
- inductive load
  - internal diode 61
  - protection from 61
- inspection
  - safety 4
- internal diode
  - and inductive loads 61
- internet links
  - Ethernet-TCP/IP 88

## K

- key
  - Remote Programmer Access 81
- kickback 61

## L

- latch
  - 24-bit 67, 103
  - counter value 67, 103
- LEDs
  - battery 57
  - DeviceNet 92
  - diagnostic 33, 57
  - error codes 58
  - Ethernet-TCP/IP 85
  - power 33, 57
  - Profibus 98
  - scan 33, 57
  - troubleshooting 33

## M

- manual cleaning procedure 6
- MMC

- analog servo module
  - connections 43, 54
  - connecting to an application 31
- CPU
  - module connections 35
  - theory of operation 59
- handling 26
- models 7
- operating limits 25
- overview 7
- ports 8, 56
- power 20, 43, 120
- SERCOS control
  - connection selector sheet 108
  - Servo Control Unit 8, 56
  - specifications 74

## models

- MMC 7

## module 9

- analog servo 9

## modules

- DeviceNet 89
- Ethernet-TCP/IP 81
- Profibus 95
- SERCOS 69

## mounting

- dimensions 13, 17
- instructions 13

## O

- operation
  - safety 4
  - startup 31
- overview
  - MMC 7

## P

- peak reverse voltage 61
- PiCPro
  - cable pinout 35
  - port pinout 35
- pinout
  - auxiliary I/O 49
  - axis connector 43
  - block I/O port 36
  - general I/O port 38

- PiCPro cable 35
- PiCPro port 35
  - user port 37
- plug and play products 107
- port
  - configuration 92
  - DeviceNet 91, 97
  - SERCOS 54
    - serial 55
- power
  - connection 41
  - distribution
    - basic 20
  - distribution in MMC 21
  - LED 33
  - switch
    - MMC 20
- power requirements
  - system 19
- power supply
  - sizing worksheet 22
- power-on diagnostics 33
- procedure
  - manual cleaning 6
  - mounting 13
  - replacing battery 72
- Profibus 95
  - connections 96
  - LEDs 98
  - specifications 100
  - theory of operation 99
- protective earth
  - grounding 2
- proximity switch
  - DeviceNet 93

## Q

- quadrature
  - encoder 9, 66, 102

## R

- Remote Programmer Access key 81
- requirements 19
- resistive load 61
- RFI
  - emission 146

- immunity 146
- RS232 port
  - ethernet 84
- run-time diagnostics 34

## S

- Safety
  - System 1
- safety
  - cleaning 6
  - electrical service & maintenance 5
  - inspection 4
  - operation 4
  - signs 2
- Scan 33
- scan
  - LED 33, 57
- Scan LED 33
- SERCOS 69
  - theory of operation 57
- SERCOS control for MMC 108
- SERCOS port 54
- serial port 55
- shielded twisted pair wiring 51
- shields 28
- signs
  - safety 2
- single point ground (SPG)
  - checklist 24
  - diagram 20
- sink configuration 45
- sizing
  - power supply 22
- source configuration 45
- specifications
  - (IEEE802.3 Ethernet-TCP/IP) 82
  - control cabinet 19
  - DeviceNet 94
  - Ethernet-TCP/IP 87
  - MMC 74
  - Profibus 100
- switch
  - main disconnect 20
  - wiring modules 32
- system
  - environment requirements 19

- grounding 24
- power requirements 19
- power supply 20
- requirements 19

## **T**

- theory of operation
  - analog input 68, 104
  - analog output 65, 69, 101
  - DC input 63
  - encoder 66, 102
  - MMC CPU 59
- troubleshooting 32
  - LEDs 33

## **U**

- user port

- pinout 37

## **V**

- voltage
  - fast transient 146
  - peak reverse 61

## **W**

- warning labels 3
- wiring
  - application 27
  - EMC compliant 27
  - shield twisted pair 51
- workstation
  - power 20

## **NOTES**