

Block I/O Modules

Part Number M.1300.7194

Version 1.0

Giddings & Lewis

Giddings & Lewis
Controls, Measurement and Sensing

NOTE

Progress is an on-going commitment at Giddings & Lewis. We continually strive to offer the most advanced products in the industry; therefore, information in this document is subject to change without notice. The illustrations and specifications are not binding in detail. Giddings & Lewis shall not be liable for any technical or editorial omissions occurring in this document, nor for any consequential or incidental damages resulting from the use of this document.

DO NOT ATTEMPT to use any Giddings & Lewis product until the use of such product is completely understood. It is the responsibility of the user to make certain proper operation practices are understood. Giddings & Lewis products should be used only by qualified personnel and for the express purpose for which said products were designed.

Should information not covered in this document be required, contact the Customer Service Department, Giddings & Lewis, 660 South Military Road, P.O. Box 1658, Fond du Lac, WI 54936-1658. Giddings & Lewis can be reached by telephone at (920) 921-7100.

M.1300.7194

Release 0201
© 2001 Giddings & Lewis, LLC

Windows 95, 98, NT, Microsoft, and MS-DOS are registered trademarks of Microsoft Corporation.
Pentium and PentiumPro are trademarks of Intel Corporation.
PiC900, PiCPro, MMC, MMC for PC, PiCServoPro, PiCTune, PiCProfile, LDO Merge, PiCMicroTerm and PiC Programming Pendant are trademarks of Giddings & Lewis, LLC

Table of Contents: Block I/O Modules

1	Safety Precautions.....	1-1
1.1	System Safety	1-1
1.1.1	User Responsibility	1-1
1.1.2	Safety Instructions.....	1-2
1.2	Safety Signs	1-2
1.3	Warning Labels.....	1-3
1.4	Safety First.....	1-4
1.5	Safety Inspection.....	1-4
1.5.1	Before Starting Operations.....	1-4
1.6	After Shutdown.....	1-4
1.7	Operating Safely	1-5
1.8	Electrical Service & Maintenance Safety	1-6
1.9	Safe Cleaning Practices	1-7
2	Guide to Using Block I/O	2-1
2.1	Attaching a Block I/O Module to the DIN Rail.....	2-1
2.2	Safety Concerns	2-2
2.3	Wiring Guidelines.....	2-3
2.4	Troubleshooting	2-6
2.4.1	Troubleshooting Table	2-6
2.4.2	Troubleshooting Communication Problems - LEDs and Blink Codes	2-7
3	Block Output 24V DC Source Module (16 Points)	3-1
3.1	Introduction.....	3-1
3.2	Connections	3-2
3.2.1	Communications Connections.....	3-4
3.2.1.1	LEDs	3-4
3.2.2	Protecting from an Inductive Load.....	3-5
3.3	Theory of Operation.....	3-6
3.4	Specification Table	3-7
4	Block Input 24V DC Module (16 points)	4-1
4.1	Introduction.....	4-1
4.2	Connections	4-2
4.2.1	Communications Connections.....	4-4
4.2.1.1	LEDs	4-4
4.3	Theory of Operation.....	4-5
4.4	Specification Table	4-7
5	Block 24V DC 8 In/8 Out Module	5-1
5.1	Introduction.....	5-1
5.2	Connections	5-2
5.2.1	Communications Connections.....	5-5
5.2.1.1	LEDs	5-5
5.2.2	Protecting from an Inductive Load.....	5-6

5.3	Theory of Operation.....	5-7
5.3.1	Outputs	5-7
5.3.2	Inputs.....	5-7
5.4	Specification Table	5-10
6	Block Output 120V AC Module (8 points)	6-1
6.1	Introduction.....	6-1
6.2	Connections	6-2
6.2.1	Fusing.....	6-3
6.2.1.1	Fuse Monitor.....	6-3
6.2.2	Communications Connections.....	6-4
6.2.2.1	LEDs	6-4
6.2.3	Protecting from an Inductive Load.....	6-5
6.3	Theory of Operation.....	6-5
6.4	Specification Table	6-6
7	Block Relay Module (8 points).....	7-1
7.1	Introduction.....	7-1
7.2	Connections	7-2
7.2.1	Normally Open Contact Form C Type.....	7-3
7.2.2	Normally Closed Contact Form C Type	7-3
7.2.3	Normally Open Contact Form A Type.....	7-4
7.2.4	Contact Noise Suppression.....	7-5
7.2.5	Communications Connections.....	7-6
7.2.5.1	LEDs	7-6
7.3	Theory of Operation.....	7-7
7.4	Specification Table	7-9
8	Block Input 120V AC Module (8 points)	8-1
8.1	Introduction.....	8-1
8.2	Connections	8-2
8.2.1	Communications Connections.....	8-4
8.2.1.1	LEDs	8-4
8.3	Theory of Operation.....	8-5
8.4	Specification Table	8-7
9	Block Input Resolver Module (6 channel)	9-1
9.1	Introduction.....	9-1
9.2	Connections	9-2
9.2.1	Adding an External Potentiometer	9-5
9.2.2	Communications Connections.....	9-6
9.2.2.1	LEDs	9-6
9.3	Resolvers.....	9-7
9.4	Theory of Operation.....	9-7
9.5	Specification Table	9-8
10	Block Output Stepper/Input Encoder/Input 24V DC Module (2/2/2 Channel) .	10-1
10.1	Introduction.....	10-1
10.1.1	Output Stepper.....	10-2
10.1.2	Input Encoder	10-2
10.1.3	Input 24V DC	10-2
10.2	Connections	10-3

10.2.1	Stepper Connections.....	10-3
10.2.2	Connecting the Block Module to Stepper Drives.....	10-5
10.2.2.1	Opto-Coupler Drive Inputs	10-6
10.2.2.2	Opto-Coupler with Common Source Drive Inputs	10-7
10.2.2.3	Single-Ended Drive Inputs.....	10-8
10.2.2.4	Differential Drive Inputs.....	10-10
10.2.3	Block Module Encoder Connections.....	10-12
10.2.3.1	Encoder Drivers	10-14
10.2.4	Block Module DC Input Connections.....	10-15
10.2.5	Power Connections.....	10-15
10.2.6	Communications Connections.....	10-16
10.2.6.1	LEDs	10-16
10.3	Theory of Operation.....	10-17
10.3.1	Stepper Theory of Operation.....	10-17
10.3.2	Block Module Encoder Theory of Operation.....	10-18
10.3.2.1	Incremental Encoders	10-18
10.3.3	DC Input Theory of Operation	10-20
10.4	Specification Table	10-22
11	Block Input Analog Module (4 Channel).....	11-1
11.1	Introduction.....	11-1
11.2	Connections	11-2
11.2.1	Communications Connections.....	11-7
11.2.1.1	LEDs	11-7
11.3	Theory of Operation.....	11-8
11.4	Specification Table	11-9
12	Block Output 4-20mA Module (4 Channel)	12-1
12.1	Introduction.....	12-1
12.2	Connections	12-2
12.2.1	Communications Connections.....	12-4
12.2.1.1	LEDs	12-4
12.3	Theory of Operation.....	12-5
12.4	Specification Table	12-6
13	Block Output +10V DC Module (4 Channel)	13-1
13.1	Introduction.....	13-1
13.2	Connections	13-2
13.2.1	Communications Connections.....	13-3
13.2.1.1	LEDs	13-3
13.2.2	Analog Output Receiving Devices.....	13-4
13.3	Theory of Operation.....	13-5
13.4	Specification Table	13-6
INDEX	IND-1

NOTES

1 Safety Precautions

READ AND UNDERSTAND THIS SECTION IN ITS ENTIRETY BEFORE UNDERTAKING INSTALLATION OR ADJUSTMENT OF BLOCK I/O MODULES

The advice contained in this section will help users to operate and maintain the equipment in a safe manner at all times.

PLEASE REMEMBER THAT SAFETY IS EVERYONE'S RESPONSIBILITY

1.1 System Safety

The basic rules of safety set forth in this section are intended as a guide for the safe operation of equipment. This general safety information, along with explicit service, maintenance and operational materials, make up the complete instruction set. All personnel who operate, service or are involved with this equipment in any way should become totally familiar with this information prior to operating.

1.1.1 User Responsibility

It is the responsibility of the user to ensure that the procedures set forth here are followed and, should any major deviation or change in use from the original specifications be required, appropriate procedures should be established for the continued safe operation of the system. It is strongly recommended that you contact your OEM to ensure that the system can be safely converted for its new use and continue to operate in a safe manner.

1.1.2 Safety Instructions

1. Do not operate your equipment with safety devices bypassed or doors removed.
2. Only qualified personnel should operate the equipment.
3. Never perform service or maintenance while automatic control sequences are in operation.
4. To avoid shock or serious injury, only qualified personnel should perform maintenance on the system.
- 5.

ATTENTION- DANGER TO LIFE
Do not touch the main power supply fuses or any components internal to the power modules while the main power supply switch is ON. Note that when the main power switch is OFF, the incoming supply cable may be live.

6. **GROUNDING (Protective Earth)**
The equipment must be grounded (connected to the protective earth connection) according to OEM recommendations and to the latest local regulations for electrical safety. The grounding (protective earth) conductor must not be interrupted inside or outside the equipment enclosures. The wire used for equipment grounding (connection to protective earth) should be green with a yellow stripe.
7. If there is any doubt at all as to the safety of the equipment, you should set the main power switch to OFF and contact your OEM for advice.

1.2 Safety Signs

The purpose of a system of safety signs is to draw attention to objects and situations which could affect personal or plant safety. It should be noted that the use of safety signs does not replace the need for appropriate accident prevention measures. Always read and follow the instructions based upon the level of hazard or potential danger.

1.3 Warning Labels

Hazard warning

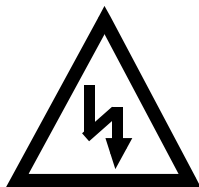

Danger Electric
Shock Risk

When you see this safety sign on a system, it gives a warning of a hazard or possibility of a hazard existing. The type of warning is given by the pictorial representation on the sign plus text if used.

The safety color is black on a yellow background with a black symbol. To ignore such a caution could lead to severe injury or death arising from an unsafe practice. If voltage levels are included in the text they must indicate the maximum level of the hazard in normal or fault condition.

Danger, Warning, or Caution warning



Symbol plus DANGER, WARNING or CAUTION:
These notices provide information intended to prevent potential personal injury and equipment damage.

Hot Surface warning

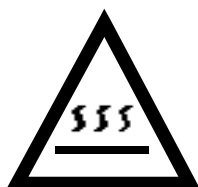

Hot Surface

1.4 Safety First

Giddings & Lewis equipment is designed and manufactured with consideration and care to generally accepted safety standards. However, the proper and safe performance of the equipment depends upon the use of sound and prudent operating, maintenance and servicing procedures by trained personnel under adequate supervision.

For your protection, and the protection of others, learn and always follow these safety rules. Observe warnings on machines and act accordingly. Form safe working habits by reading the rules and abiding by them. Keep these safety rules handy and review them from time to time to refresh your understanding of them.

1.5 Safety Inspection

1.5.1 Before Starting Operations

1. Ensure that all guards and safety devices are installed and operative and all doors which carry warning labels are closed and locked.
2. Ensure that all personnel are clear of those areas indicated as potentially hazardous.
3. Remove (from the operating zone) any materials, tools or other objects that could cause injury to personnel or damage the system.
4. Make sure that the control system is in an operational condition.
5. Make certain that all indicating lights, horns, pressure gauges or other safety devices or indicators are in working order.

1.6 After Shutdown

Make certain all controlled equipment in the plant is safe and the associated electrical, pneumatic or hydraulic power is turned off. It is permissible for the control equipment contained in enclosures to remain energized provided this does not conflict with the safety instructions found in this section.

1.7 Operating Safely

1. Do not operate the control system until you read and understand the operating instructions and become thoroughly familiar with the system and the controls.
2. Never operate the control system while a safety device or guard is removed or disconnected
3. Where access to the control system is permitted for manual operation, only those doors which provide that access should be unlocked. They should be locked immediately after the particular operation is completed.
4. Never remove warnings that are displayed on the equipment. Torn or worn labels should be replaced.
5. Do not start the control system until all personnel in the area have been warned.
6. Never sit or stand on anything that might cause you to fall onto the control equipment or its peripheral equipment.
7. Horseplay around the control system and its associated equipment is dangerous and should be prohibited.
8. Know the emergency stop procedure for the system.
9. For maximum protection when carrying out major servicing requiring the system to be powered down, the power source should be locked using a lock for which only you have the key. This prevents anyone from accidentally turning on the power while you are servicing the equipment.
10. Never operate the equipment outside specification limits.
11. Keep alert and observe indicator lights, system messages and warnings that are displayed on the system.
12. Do not operate faulty or damaged equipment. Make certain proper service and maintenance procedures have been performed.

1.8 Electrical Service & Maintenance Safety

1. **ALL ELECTRICAL OR ELECTRONIC MAINTENANCE AND SERVICE SHOULD BE PERFORMED BY TRAINED AND AUTHORIZED PERSONNEL ONLY.**
2. It should be assumed at all times that the POWER is ON and all conditions treated as live. This practice assures a cautious approach which may prevent accident or injury.
3. To remove power:
**LOCK THE MAIN SWITCH IN THE OPEN POSITION.
USE A LOCK TO WHICH ONLY YOU HAVE THE KEY.**
4. Make sure the circuit is safe by using the proper test equipment. Check test equipment regularly
5. Capacitors take time to discharge. Care should be taken in manual discharging of capacitors
6. There may be circumstances where troubleshooting on live equipment is required. Under such conditions, special precautions must be taken:
 - Make sure your tools and body are clear of the areas of equipment which may be live.
 - Extra safety measures should be taken in damp areas.
 - Be alert and avoid any outside distractions.
 - Make certain another qualified person is in attendance.
7. Before applying power to any equipment, make certain that all personnel are clear of associated equipment.
8. Control panel doors should be unlocked only when checking out electrical equipment or wiring. On completion, close and lock panel doors.
9. All covers on junction panels should be fastened closed before leaving any job.
10. Never operate any controls while others are performing maintenance on the system.
11. Do not bypass a safety device.
12. Always use the proper tool for the job.
13. Replace the main supply fuses only when electrical power is OFF (locked out).

1.9 Safe Cleaning Practices

1. Do not use toxic or flammable solvents to clean control system hardware.
2. Turn off electrical power (lock out) before cleaning control system assemblies.
3. Keep electrical panel covers closed and power off when cleaning an enclosure.
4. Always clean up spills around the equipment immediately after they occur.
5. Never attempt to clean a control system while it is operating.
6. Never use water to clean control equipment unless you are certain that the equipment has been certified as sealed against water ingress. Water is a very good conductor of electricity and the single largest cause of death by electrocution.

NOTES

2 Guide to Using Block I/O

This section covers the following:

- Attaching a block I/O module to a DIN rail
- Wiring guidelines
- Troubleshooting guide

2.1 Attaching a Block I/O Module to the DIN Rail

1. Hook the top edge of the module's DIN rail slot (see Back View below) onto the top of the DIN rail.
2. Insert a small flatheaded screwdriver into the latch slot (located on the lower right-hand side - see Front View below) angling upwards in order to catch the latch handle.
3. Gently pull the latch handle down by leveraging the screwdriver toward the module. Press the module in place and release the latch handle.
4. To remove the module from the DIN rail, reverse the above procedure.

NOTE: The metal strap must make a good connection to the DIN rail when the module is pressed into place. This ensures a good electrical connection to chassis ground (assuming the DIN rail is making good electrical connection to chassis).

Figure 2-1 Attaching Module to DIN Rail

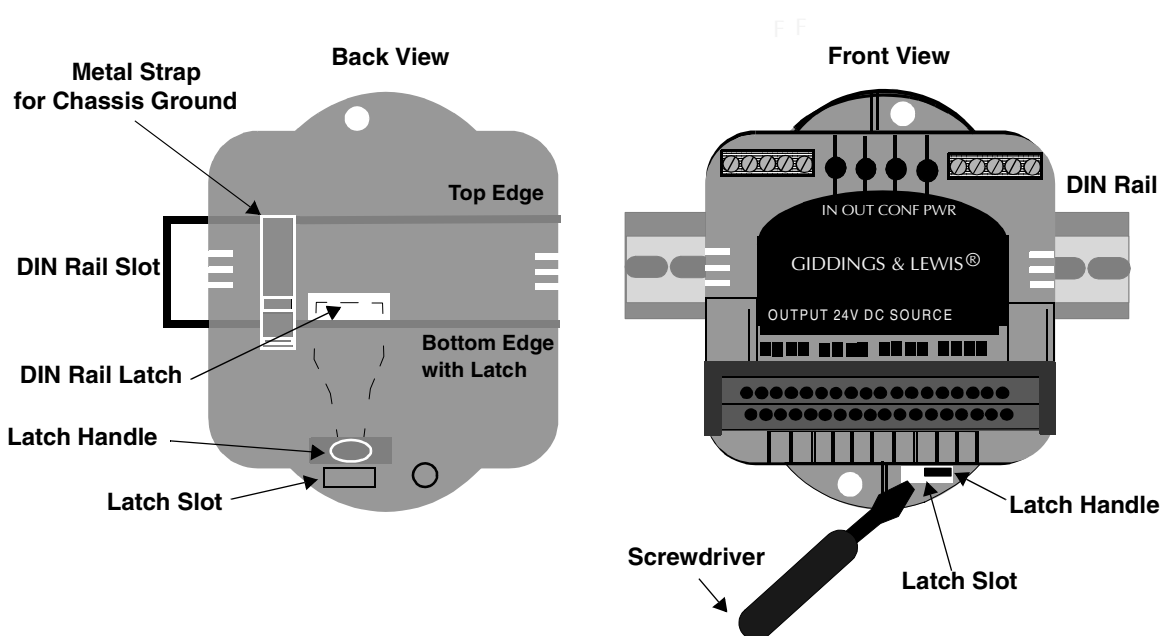

Use the mounting dimensions in Figure 2-2 when not using a DIN rail.

Figure 2-2 Mounting Dimensions

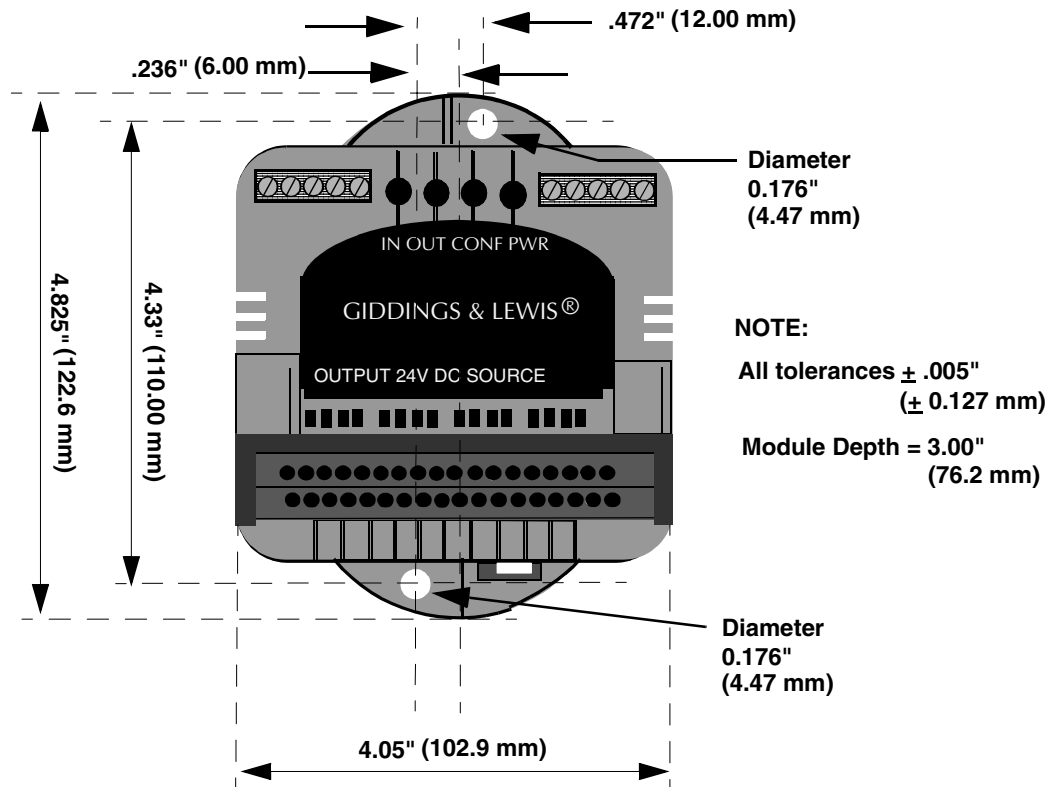

2.2 Safety Concerns

The following information is provided to ensure compliance to the low voltage directive (73/23/EEC) when using block I/O modules.

1. Each block I/O module has an internal 24 V to 5 V converter for its logic circuitry. In the unlikely event of a certain component failure within this converter and unlimited current from the 24 V power supply, there is a possibility of a momentary flame inside the module. If this is a concern, the 24 V to the module must be fused to limit current to below 10 amps. (Use a slow blow type to allow for power-on inrush). One or more modules may be on the same fuse.
2. Block I/O DC outputs are protected from short circuits but not from continuous overloads. For example, it is acceptable for a group of outputs to source 4 amps, with each output sourcing .5 amps each. Any of those outputs can safely handle a continuous short circuit. However, there is a possibility of a momentary flame inside the module if an output is allowed to draw more than 10 amps continuously. If continuous overloads are considered a possibility in a given application, it is recommended to fuse each group of outputs at 5 amps or less.

2.3 Wiring Guidelines

The wiring practices specified in Appendix O.1 - EMC Guidelines should be followed when working with the block I/O modules.

NOTE

Giddings & Lewis continues to recommend separation of low level signals (encoder, analog, communications, fast DC inputs) from high voltage or high current lines from any of the above. More specifically, maintain at least one inch of separation around encoder signals and around communication signals.

The following additional information is provided because of the many possible ways to distribute block I/O modules.

It is important to maintain the concept of a single point ground (SPG) with any distribution pattern used. Any ground loop(s) will compromise the use of chassis ground by each block I/O module to reduce emissions and to provide immunity to electrical noise.

The shields and I/O lines are capacitively coupled to the metal strap located on the back of the module and also to the chassis pin located on the terminal block in the front of the module. Chassis ground connection is made through the metal strap to the DIN rail (which requires a good electrical connection to chassis) or through a six inch (or less) 14 AWG (2 mm²) wire from the chassis pin.

Figure 2-3 illustrates a basic block I/O setup. The block I/O modules are distributed around a machine assembly. It is assumed that the metal structure of the assembly provides the best common chassis ground. Modules are connected to this chassis ground via a DIN rail or a separate wire to the chassis pin of the module.

A heavy gauge wire or flat braided cable is used to connect the machine assembly chassis to the SPG of the main control enclosure. When a variable frequency drive or similar noisy device is installed on the machine assembly, maintaining the SPG concept is more difficult.

The frame of the drive is usually connected to the structure of the machine assembly. This can introduce noise between the chassis of the machine assembly and the SPG. However, this noise can be reduced by ensuring that a ground wire is run parallel with the drive's power wires and is connected to the SPG. This is typically the green safety ground wire specified by the drive manufacturer and should be of the same gauge as the power wires.

Figure 2-3 Remote Block I/O distributed around One Machine Assembly

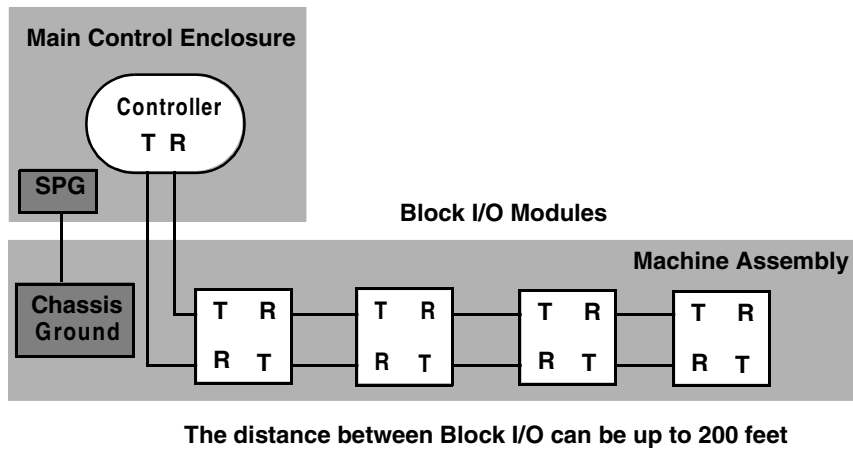
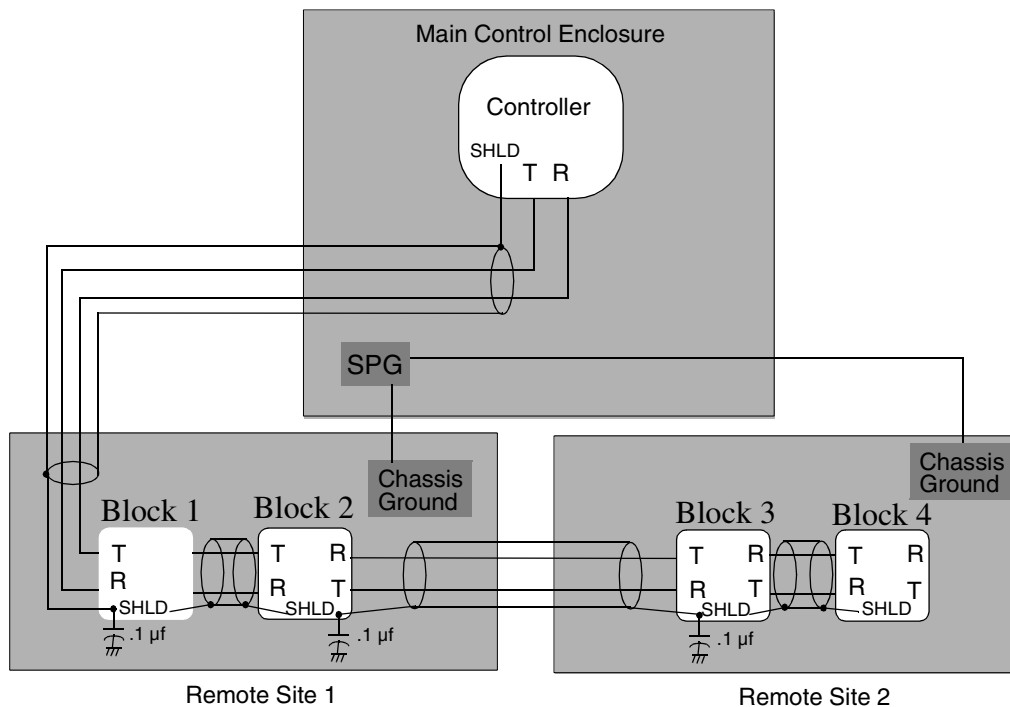

Figure 2-4 illustrates the distribution of the block modules around several sites that do not have the same common chassis ground. The chassis ground of each site should be connected to the SPG in the main control enclosure.

Regardless of these connections to SPG, noise sources in the main control and/or in the remote sites may cause momentary potential differences between chassis grounds. If the differences are too great, some communication messages will be corrupted and will have to be retransmitted. To reduce or eliminate communication retries associated with momentary ground differences, use .1 μf capacitors to connect shield to chassis for communication cables entering and leaving a remote site. NOTE: The shield connection to the PiC900/90 CPU is already internally connected to SPG through a .1 μf capacitor.

Figure 2-4 Remote Block I/O Distributed around Several Sites



The distance between block I/O modules can be up to 200 feet.

2.4 Troubleshooting

2.4.1 Troubleshooting Table

Problem	Indication or Solution
Communication/configuration error: <ul style="list-style-type: none"> • block communication circuitry failure • open communication cable • shorted communication cable • wrong block (ID) at given location 	Generally, the diagnostic LED on the CPU blinks a three digit error code to indicate the block location of the first error detected. The first digit flashes a "3" to indicate it is a block I/O problem. The number of flashes in the second and third digits indicates the block I/O module (01 through 77). The second digit will flash a 1 - 7, 10 for 0. The third digit will flash a 1 - 9, 10 for 0. For example, if the second digit flashes 3 times and the third digit flashes 10 times, the module is 30 . See the next section for more information on troubleshooting communication problems.
24V missing	Block module power LED is off.
24V reversed	Block module power LED is off. Circuitry is diode protected.
24V too high (over the 30V specification)	Block I/O circuitry is protected against high voltage transients by on-board varistors. However, the module may be damaged by steady-state excessive high voltage.
24V too low (below the 20V specification)	After voltage drops below a non-guaranteed safety margin, there will be communication errors. An even lower voltage will cause the on-board voltage monitor to hold the circuitry in reset and the green power LED off. However, there is a voltage level which allows communications to function but prevents proper operation of the I/O. When in doubt, check the 24V level.
Intermittent communication errors due to noise	CPU blinks the 232 communication error code.
Field side failure	Use normal ladder troubleshooting methods.

2.4.2 Troubleshooting Communication Problems - LEDs and Blink Codes

The status of the configuration and power LEDs for each block module provides the most basic information for locating a communication problem. In general, a good troubleshooting technique is to turn the RUN/STOP switch on the PiC to the STOP position, turn off the 24V DC power to the block I/O modules, and then turn the 24V DC supply back on again. (Note: Power may have to be turned on sequentially to groups of modules if the power supply can not handle the approximate 100 μ sec inrush of 2.5A per module.

The green power LED of each module should be on as soon as 24 Vdc is applied to each module. The green configuration LED should go on for each properly wired module in the configuration after the scan has started. This LED will be off for all modules beyond the location of any module with a wiring problem. If none of the configuration LEDs illuminate on, the problem may be a reversal of the receive wires at the CPU. If "Data in and Data out" LEDs illuminate, there may be a problem in the return path connections.

The "Data in" and "Data out" LEDs indicate data flow with respect to the CPU. During operation, these LEDs emit a faint glow indicating normal communications. When a failure occurs, they can either be "OFF" or in a steady "ON" state

A block's "Data out" LED is an indication of data flow from the CPU or from the previous block. The "Data in" LED indicates data flow from the block to the CPU or data flow from the next block.

Figure 2-5 Transmission of Data Between Controller and Block Modules

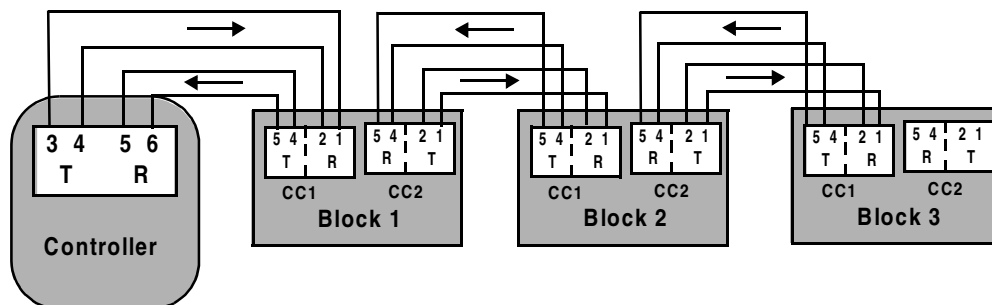

NOTE: CC represents the communication connections at the top of the block modules.

T = Transmit

R = Receive

The "Data in" and "Data out" LED status for several types of wiring errors is shown in Table 1-1 that follows. This can be used as a guideline for what could happen at other locations. It is assumed that the 24VDC power has been cycled off/on to ensure that each block can be configured.

IMPORTANT

When a communication error occurs, a three digit error code is flashed on the CPU's diagnostic LED. This indicates the location of the module where communication was interrupted. *It is not necessarily the location of the error itself.* Therefore, it is important to restart the program by turning the RUN/STOP switch to stop and back to run. The diagnostic LED will provide information to help locate where there is an error.

FIRMWARE NOTICE

Firmware for PiCPro 11.0 or higher should be installed on CPUs with Block I/O. This version allows the user to accurately troubleshoot Block I/O.

Table 1-1 LEDs and Blink Codes

Blink Codes	Block 1 LEDs				Block 2 LEDs				Failure/Error @ CC2 of block 1 or CC1 of block 2*
	Data In	Data Out	CFG	PWR	Data In	Data Out	CFG	PWR	
301 (3-10-1)	Off	Off	On	On	Off	Off	On	On	4 and 5 reversed on CC1 of Block 1
301 (3-10-1)	Off	Off	On	On	Off	Off	On	On	4 and 5 shortened on CC1 of Block 1*
301 (3-10-1)	Off	Off	On	Off	Off	Off	On	On	4 or 5 open on CC1 of Block 1
301 (3-10-1)	Off	On	On	On	Off	Off	On	On	1 or 2 open, reversed, or shortened on CC1 of Block 1*
301 (3-10-1)	On	Off	On	On	Off	Off	On	On	4 and 5 reversed on CC2 of Block 1 or CC1 of block 2
302 (3-10-2)	Off	Off	On	On	Off	Off	On	On	4 or 5 shortened on CC2 of Block 2*
302 (3-10-2)	Off	Off	On	On	Off	Off	On	On	4 or 5 open on CC2 of block 1 or CC1 of block 2
302 (3-10-1)	Off	Off	On	On	Off	On	On	On	1 or 2 open, reversed, or shortened on CC2 of Block 1 or CC1 of Block 2*
302 (3-10-2)	Off	Off	On	On	Off	On**	On	On	CC1 and CC2 reversed at Block 2
301 (3-10-1)	Off	On	Off	On	Off	Off	Off ***	On	CC1 failed on Block 1
302 (3-10-2)	Off	Off	On	On	Off	On	Off ***	On	CC2 failed on Block 1 or CC1 failed on Block 2

- * The communications drivers are internally short circuit protected.
- ** The data out LED of block 3 will also be illuminated.
- *** If "Data In" LED is Bright or if "Data In" and "Data Out" are pulsing with equal intensity, monitor "Data Out" of each Block starting with Block 1. Check the wiring between blocks whose "Data Out" signals are opposite (ON vs. OFF).
- **** CFG of next block will also be OFF.

The following flowchart provides an alternative troubleshooting guide. The flowchart assumes that the 24VDC power has been cycled off/on to ensure each block can be configured.

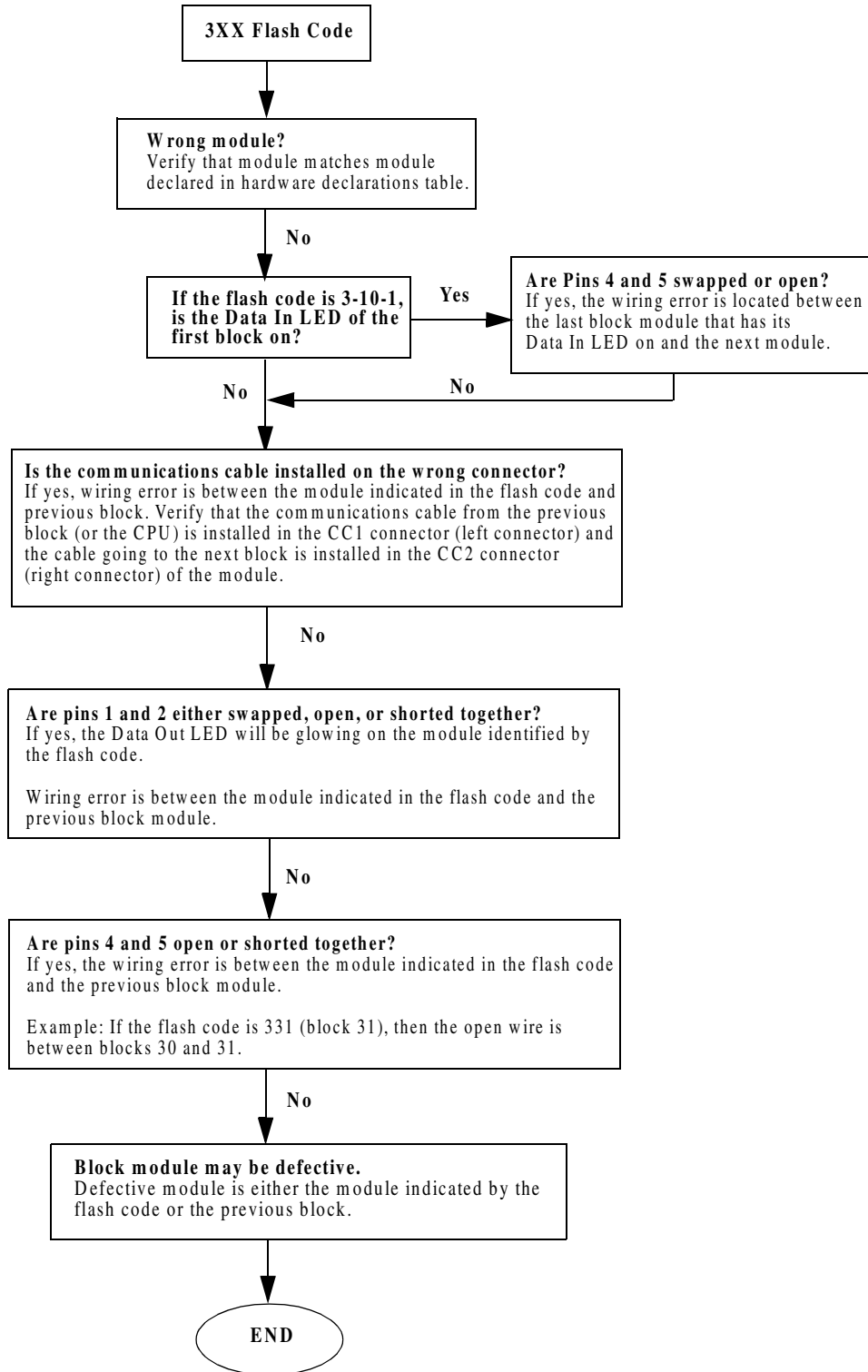

3 Block Output 24V DC Source Module (16 Points)

3.1 Introduction

The 16 point 24V DC block output module sources voltage for individual loads from one or more DC power supplies. Each external supply is nominally 24 volts, but can be between 20 and 30 volts.

16 LEDs near the field terminal connector of the module indicate the logic state that drives each output. Another LED labeled SC turns on if any output attempts to drive a short circuit.

Figure 3-1 Block Output 24V DC Source Module (16 point)

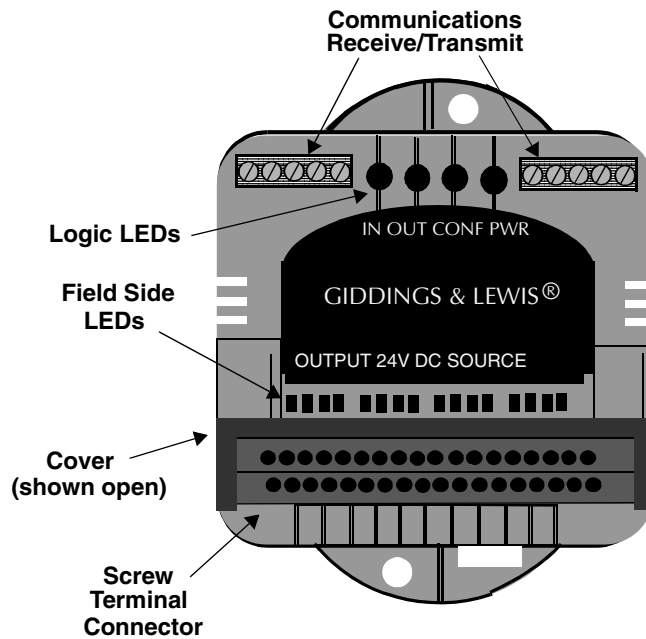

3.2 Connections

A screw terminal connection is provided for each output and for each external power supply connection. The outputs are isolated in two groups of eight as shown in Figure 3-2.

The external DC supply that powers the output signals should have a wire connected from its 0V (COMMON) terminal directly to the single point ground used for the system rack.

Figure 3-2 Screw Terminal Connection Assignments

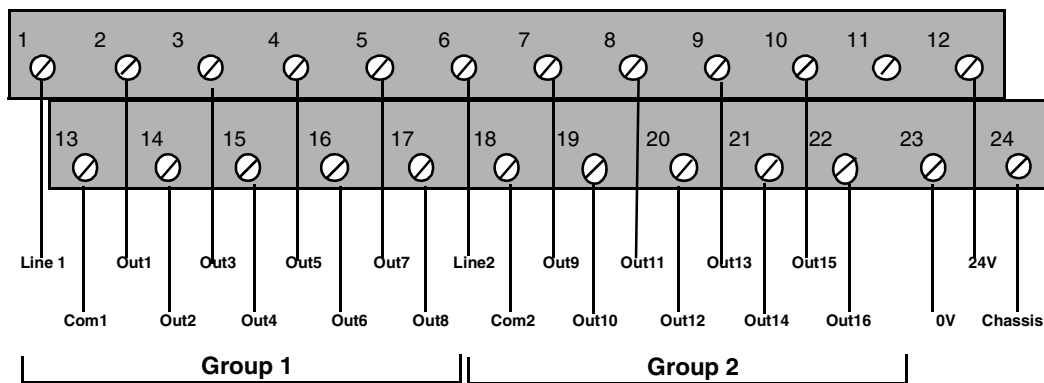

Each group has its own short circuit protection. However, there is just one short circuit LED indicator.

Connections for one group of outputs are illustrated in Figure 3-3.

The common side of each load must be connected to the 0V terminal of the supply. This 0V terminal is connected to the SPG used by the system rack.

Use up to 14 AWG for field side wiring.

Figure 3-3 Connections for One Group of Outputs

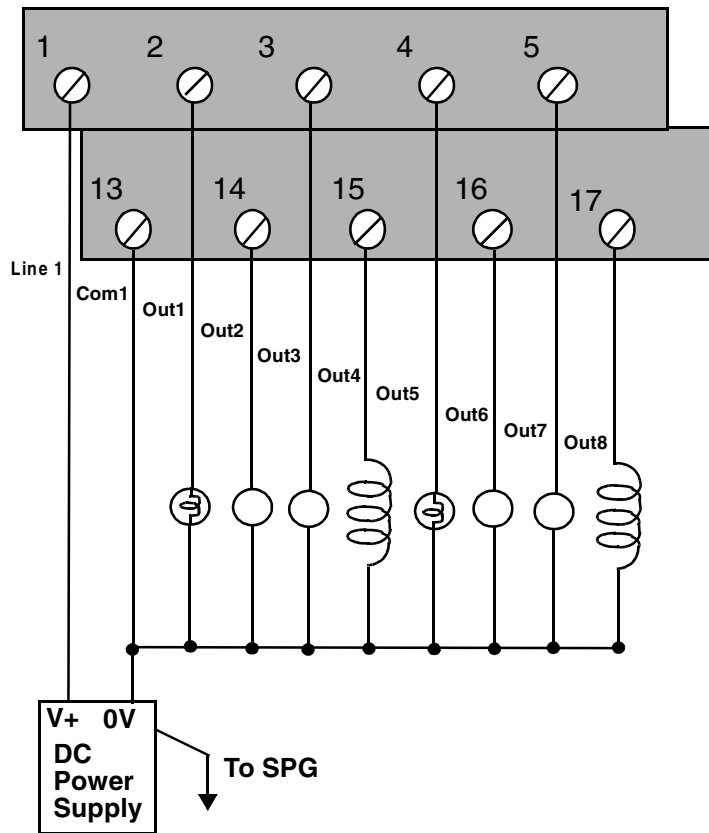

3.2.1 Communications Connections

There are two 5-pin communications connectors and four logic LEDs on the top of the block I/O module as shown in Figure 3-4 below.

Figure 3-4 Pinouts for Communication Connectors

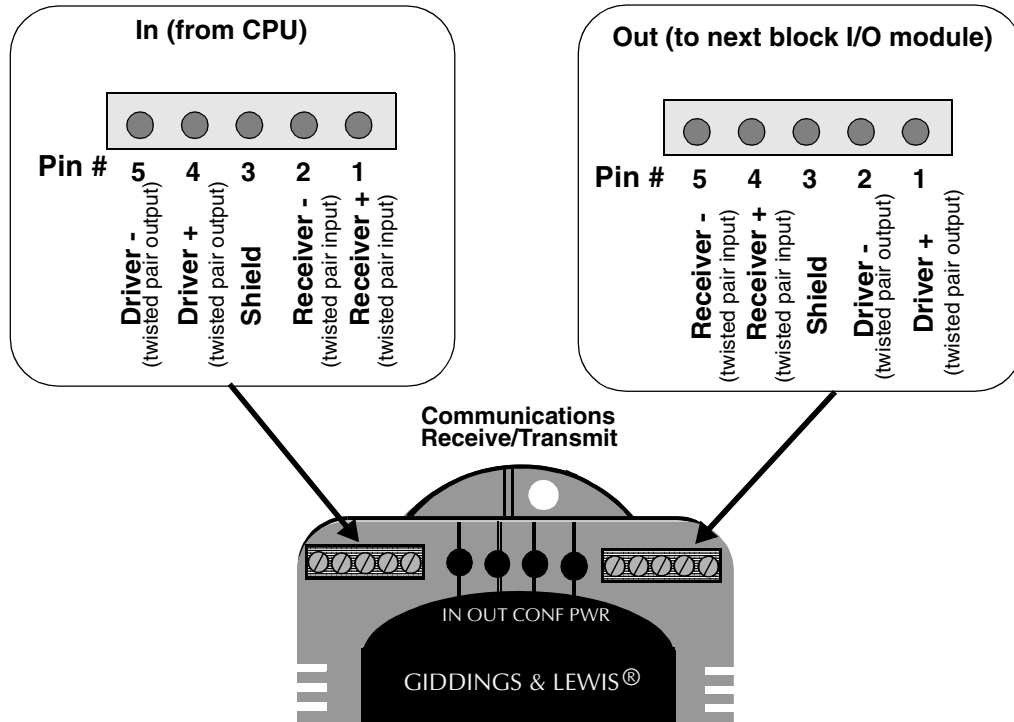

3.2.1.1 LEDs

LED	Color	State	Definition
DATA IN	Yellow	FAINT	Data being passed through the block module
		BRIGHT or OFF	No activity through the block module
DATA OUT	Yellow	FAINT	Data is being passed through the block module
		BRIGHT or OFF	No activity through the block module
CONFIG	Green	ON	Communication established with this block I/O module
		OFF	Communication not established
PWR	Green	ON	Internal +5V logic power supply OK
		OFF	No external 24V applied or internal 5V logic supply not OK

3.2.2 Protecting from an Inductive Load

Resistive loads can be connected to the module and controlled by the system with no precautions other than making sure they have a connection to the common of the DC power supply.

Inductive loads have an electrical "kickback" when current is stopped. This can damage or destroy the output switching device. Each output in the Output 24V DC module has a diode through which reverse current can be safely routed.

Figure 3-5 shows how the internal diode works with an inductive load. When an output is energized, represented in Figure 3-5a by a closed switch, current passes through the load into the common line. When the output is de-energized, represented in Figure 3-5b by an open switch, current stops and the inductive field collapses. The state of the outputs is controlled by the CPU module. This creates a reverse voltage across the load called "kickback" which tries to continue the current. The voltage is in series with the DC power supply. The combined voltage appears across the output switching device in the module.

If this were the only path available, voltage across the device would peak at several hundred volts. The internal diode provides another path for current. This limits the peak reverse voltage across the load to less than 1 V. Every switch in the Output 24V DC module has this protection so you can connect an inductive load to any terminal.

Figure 3-5 Diagram of Internal Protection for Inductive Loads

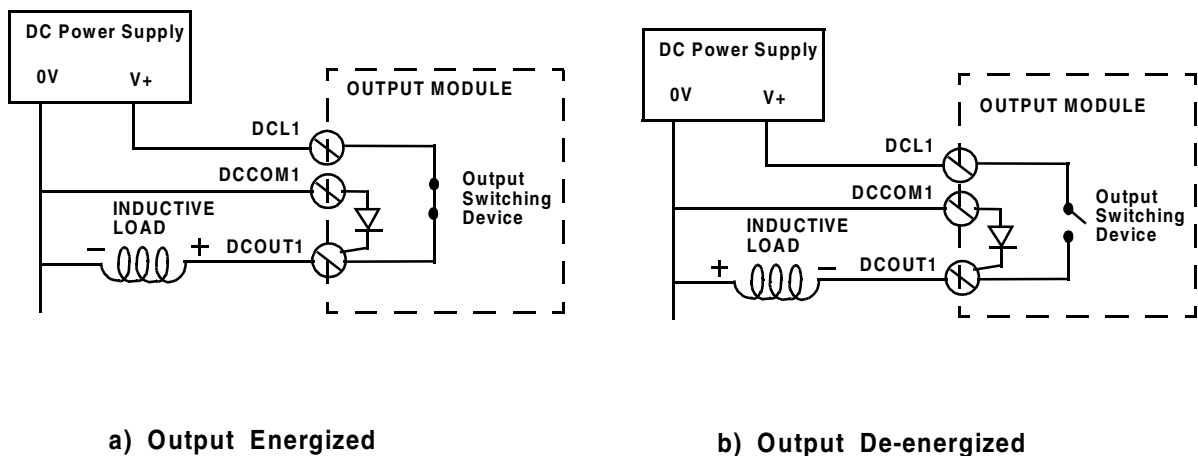

3.3 Theory of Operation

Each output point is a solid state switch rated at .5 A. It turns on or off according to the logic state sent to it by the CPU. If the CPU sends it a logic 1, the switch closes and the device is powered. If the CPU sends a logic 0, the switch opens and power to the device is cut off. The CPU updates the logic state for each switch every time it scans the program.

The logic side of the switch is optically isolated from the field side. An LED gives the logic state of each switch. If you need to know whether voltage is actually present at the field side, use a voltmeter on the terminal screws.

Each group has a .1 ohm series sensing resistor to protect against current overload in case the outputs are shorted to ground. When a short circuit condition is sensed, all outputs are pulsed on for approximately 130 microseconds every 100 millisecond. Normal operation resumes after the short is removed. In addition, each output is protected with internal clamping diodes. Without clamping, high voltage transients (kickback) from inductive loads might damage the module.

3.4 Specification Table

Characteristic	Block Output 24V DC module specifications
Function	Sources an external DC supply to 16 loads
Part number	M.1017.3095 (old # 503-25908-01)
DC source requirements	Nominal 24V DC; range 20 to 30 VDC
Field side connector	Two 12-pin connectors, screw terminals
Protection of logic circuits	Optical isolation between the logic and field side, transient suppression on the 24V external supply
Grouping of outputs	Two groups of 8 solid-state switches. Each group may use its own DC supply, or one supply may be daisy-chained. These must be referenced to 0V.
Short circuit protection for each group	Pulses output for about 130 μ sec every 100 msec until short is removed
Maximum current per group	4 A of continuous current for the group; each switch is rated at .5 A continuous
Logic side LEDs, module status	Data In LED Data Out LED Configured LED Power LED
Logic side LEDs, output status	A yellow LED for each output
Logic side LED, short circuit status	A red LED lights to indicate a short circuit condition
Switch characteristics	Solid-state switches
Time delay on for resistive loads	50 μ sec max
Time delay off for resistive loads	50 μ sec max
Leakage current in off state	0.5 mA max
Switch voltage, maximum ON	1 VDC max
Surge current, maximum	25 A for 130 μ sec, every 100 msec
Response to scan loss	All outputs are reset to the OFF state
Module power requirements	100 mA from an external 24V DC supply (20 to 30V DC range) NOTE: 2.5A, 250 microsecond inrush at power on

Block Output 24V DC Source Module (16 Points)

CE Marked	<p>Conforms to Directives 73/23/EEC, 89/336/EEC, 92/31/EEC, 93/68/EEC by conforming to the following standards:</p> <p>EN 50081-2:1993 EMC Generic Industrial Emissions EN 50082-2:1995 EMC Generic Industrial Immunity EN 61131-2:1994/A11:1996 Low voltage directive requirements for programmable controllers</p> <p>Operates with emissions below EN55011/ CISPR 11 Class A limits</p> <p>Immune to:</p> <ul style="list-style-type: none"> • Electrostatic discharge (4K V contact mode, 8K V air discharge) per EN61000-4-2 • RF electromagnetic fields per EN61000-4-3, ENV 50141, and ENV50204 • Electrical fast transients per EN61000-4-4 • Magnetic fields per EN61000-4-8 <p>Refer to the EMC Guidelines for more information.</p>
UL and C/UL Listed	File No. E126417 NRAQ Programmable Controllers
Operating temperature range	7° C to 55° C (45° F to 131° F)
Storage temperature range	-40° C to 85° C (-40° F to 185° F)
Humidity	5 to 95%, non-condensing
Physical size	4.05" wide x 4.825" high x 3" deep 102.9 mm x 122.6 mm x 76.2 mm
Vibration (per IEC 68-2-6)	10-57 Hz (constant amplitude .15 mm) 57 - 2000 Hz (acceleration 2 g)
Shock (per IEC 68-2-27)	Four shocks per axis (15g/11 msec)

4 Block Input 24V DC Module (16 points)

4.1 Introduction

The input 24V DC module converts DC signals from devices into logic levels that the CPU can use. Each signal is converted into a corresponding logic 1 or 0 which is transmitted through the communication interface to the CPU module. An "on" signal is nominally 24 VDC, but can be any level between 15 and 30 volts. An "off" signal is any level below 5V. The wiring configurations may be sink or source.

Figure 4-1 Block Input 24V DC Module 16 point

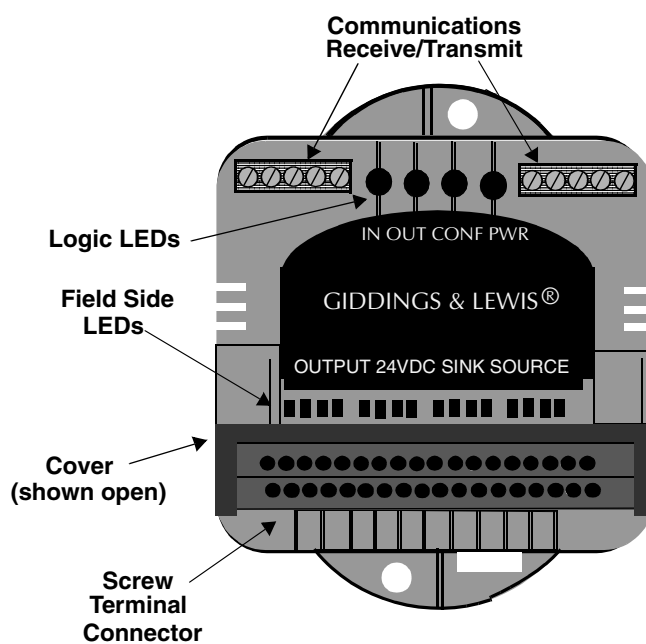

4.2 Connections

A screw terminal connector is provided for each input and for each external power supply connection. The inputs are isolated in two groups of eight, with one additional terminal per group for the DC source/sink connection. The devices connected to terminals in the same group have a common DC supply and are wired in the same configuration, sink or source (Figure 4-2).

The external DC supply that powers the input signals should have a wire connected from its 0V (COMMON) terminal directly to the single-point ground used for the system rack.

Figure 4-2 Screw Terminal Connector Assignments

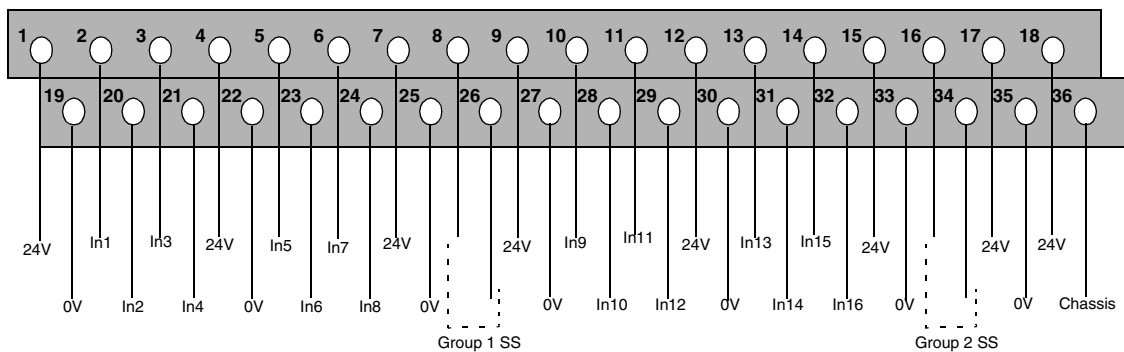

Typically, an external 24V DC supply is connected to pins 18 and 35. These pins are internally jumpered so that the supply is available at the other pins labeled as 24V and 0V. This makes it convenient to connect a 3-wire device (e.g., a proximity switch) which requires a voltage and ground connection. Also, 24V or 0V can be easily jumpered to a group's sink/source connection.

Figure 4-3 illustrates two groups of inputs using the same power supply. Each group can work independently of the other; one group may be sink and the other source. The DC power supply for each group may be different if required, but must be referenced to the same ground. Typically just one DC power supply is used, daisy-chained from one group to the next.

In Figure 4-3a, one group of eight inputs is shown with devices "sinking" current through the block DC Input module. The HOT terminal of the power supply is connected internally to the module by the jumper between 24V and Group 1 or 2 SS. The second group of eight inputs is shown with devices "sourcing" current through the block DC Input module. The COMMON terminal of the power supply is connected internally to the module by the jumper between 0V and Group 2 or 1 SS.

In Figure 4-3b, the first group is shown with devices "sourcing" current through the block DC Input module. The second group is shown with devices "sinking" current through the block DC Input module. In both examples the DC power supply is the same for Group 1 and 2. Use up to 14 AWG for field side wiring.

Figure 4-3 Connectors for Two Groups of Inputs

a. Group 1 Sink (Pins 8 and 9 Jumpered) and Group 2 Source (Pins 33 and 34 Jumpered)

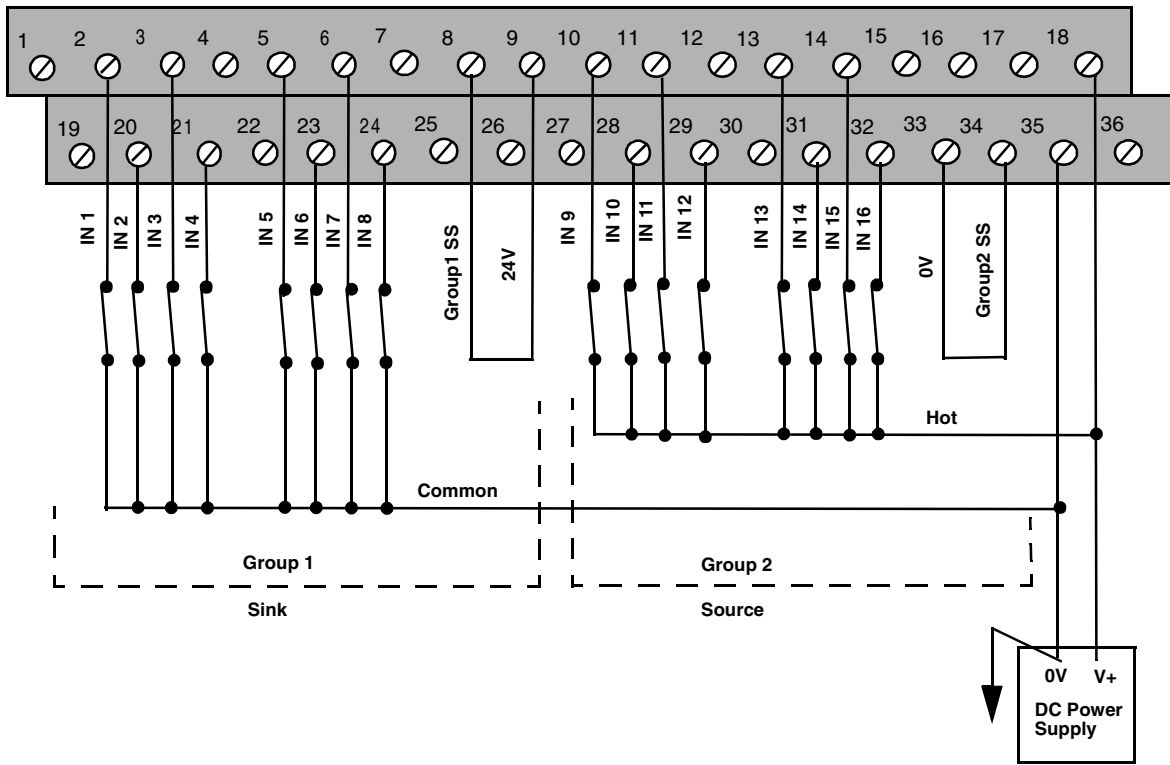

b. Group 1 Source (Pins 25 and 26 Jumpered) and Group 2 Sink (Pins 16 and 17 Jumpered)

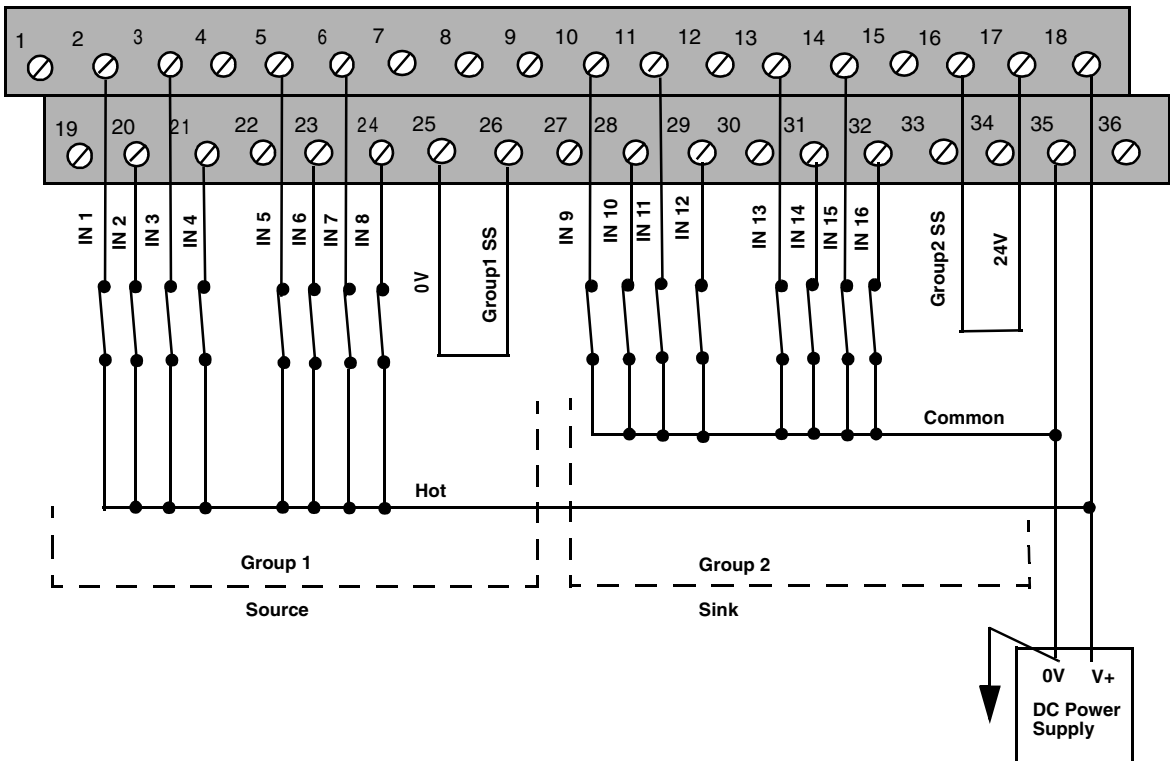

4.2.1 Communications Connections

There are two 5-pin communications connectors and four logic LEDs on the top of the block I/O module as shown in Figure 4-4.

Figure 4-4 Pinouts for Communication Connectors

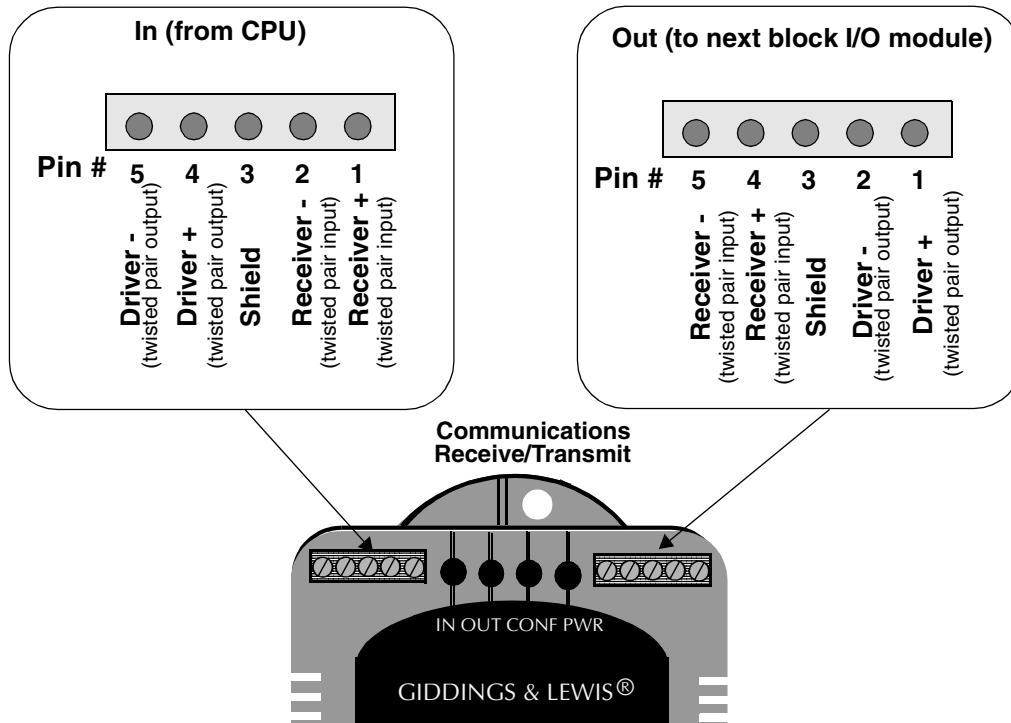

4.2.1.1 LEDs

LED	Color	State	Definition
DATA IN	Yellow	FAINT	Data being passed through the block module
		BRIGHT or OFF	No activity through the block module
DATA OUT	Yellow	FAINT	Data is being passed through the block module
		BRIGHT or OFF	No activity through the block module
CONFIG	Green	ON	Communication established with this block I/O module
		OFF	Communication not established
PWR	Green	ON	Internal +5V logic power supply OK
		OFF	No external 24V applied or internal 5V logic supply not OK

4.3 Theory of Operation

Each input is guaranteed "on" at 15 to 30 VDC and guaranteed "off" at 0 to 5 VDC; polarity doesn't matter. Its on/off state is converted to a corresponding logic 1 or 0. This logic state is transmitted through the communication interface to the CPU module, where the processor uses it as data in the ladder program. The logic side of the input is optically isolated from the field side.

An LED in the upper section of the module indicates the logic state of each input. Each group is represented by a horizontal row of LEDs. If you need to know whether voltage is present at the field side, use a voltmeter on the terminal screws. The shaded blocks in Figure 4-5 show the limits specified by the IEC. The lines show the maximum and minimum V/I of the inputs in this module. The voltage/current curve in this graph shows that the input module is well within the IEC Type 1 limits.

Figure 4-5 Input Characteristics Compared to IEC Standards

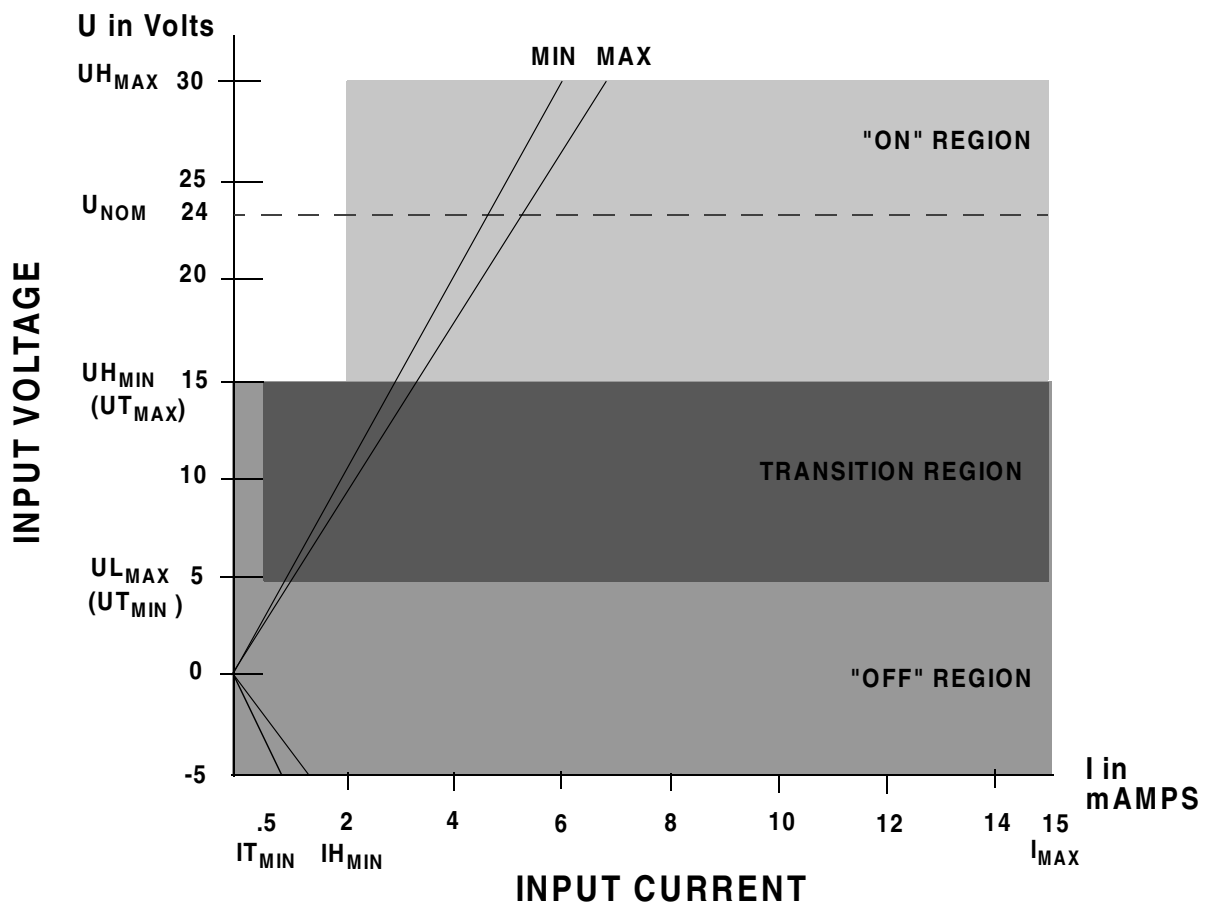

IMPORTANT

Switching devices can sometimes have a leakage current that exceeds the $I_{T_{min}}$ (current allowed when off) of an input module. In order to use such a device, an impedance (typically, a resistor) needs to be used in parallel with the input.

For example, some of the newer proximity switches use two wires instead of three. The third wire was used for a power or ground line. Without the third wire, the switch is easier to install. However, it requires more leakage current in the off state to power its internal circuitry.

As a conservative estimate, use the following formula to calculate an external resistance value. It keeps the input voltage at or below 2.4V when the switching device is in the "off" state.

$$\frac{2.4V}{\text{Switch Leakage} - 0.75mA} \geq R$$

If the switch leakage specification is ≤ 1.7 mA, then:

$$\frac{2.4V}{1.7 - 0.75mA} \geq 2.5K\Omega$$

Use a resistor less than or equal to 2.5 K Ω . Be sure that the wattage is adequate for the resistor when the switching device is in the "on" state remembering that:

$$P = \frac{V_{ON}^2}{R}$$

4.4 Specification Table

Characteristic	Block Input 24V DC module specifications
Function	Monitors on/off states from DC voltage inputs
Part number	M.1017.3092 (old # 503-25907-01)
Field side connector	Two 18-pin connectors, screw terminals
Input signals (meet IEC standards)	Nominal 24 VDC on, 0 VDC off
UH Max (max. allowed voltage)	30 VDC
IH Max (max. current @ 30 VDC)	7.5 mA
UL Min	Polarity independent
Guaranteed on	15 VDC
IH Min (min. current @ UH Min)	2.8 mA
Guaranteed off	5 VDC
IT Min (current allowed when off)	.75 mA
Time delay on	1 ms max.
Time delay off	1 ms max.
Protection of logic circuits	Optical isolation between the logic and field sides, transient suppression on the 24V external supply
Logic side LEDs, module status	Data In LED Data Out LED Configured LED Power LED
Logic side LEDs, input circuits	A yellow LED for each input
Module power requirements	100 mA from an external 24V DC supply (20 to 30V DC range) NOTE: 2.5A, 250 microsecond inrush at power on

CE Marked	<p>Conforms to Directives 73/23/EEC, 89/336/EEC, 92/31/EEC, 93/68/EEC by conforming to the following standards:</p> <p>EN 50081-2:1993 EMC Generic Industrial Emissions EN 50082-2:1995 EMC Generic Industrial Immunity EN 61131-2:1994/A11:1996 Low voltage directive requirements for programmable controllers</p> <p>Operates with emissions below EN55011/ CISPR 11 Class A limits</p> <p>Immune to:</p> <ul style="list-style-type: none"> • Electrostatic discharge (4K V contact mode, 8K V air discharge) per EN61000-4-2 • RF electromagnetic fields per EN61000-4-3, ENV 50141, and ENV50204 • Electrical fast transients per EN61000-4-4 • Magnetic fields per EN61000-4-8 <p>Refer to the EMC Guidelines for more information.</p>
UL and C/UL Listed	File No. E126417 NRAQ Programmable Controllers
Operating temperature range	7° C to 55° C (45° F to 131° F)
Storage temperature range	-40° C to 85° C (-40° F to 185° F)
Humidity	5 to 95%, non-condensing
Physical size	4.05" wide x 4.825" high x 3" deep 102.9 mm x 122.6 mm x 76.2 mm
Vibration (per IEC 68-2-6)	10-57 Hz (constant amplitude .15 mm) 57 - 2000 Hz (acceleration 2 g)
Shock (per IEC 68-2-27)	Four shocks per axis (15g/11 msec)

5 Block 24V DC 8 In/8 Out Module

5.1 Introduction

The Block 24V DC 8/8 module provides eight output points and eight input points.

The eight point output section sources voltage for individual loads from a DC power supply. The external supply is nominally 24 volts, but can be between 20 and 30 volts. Eight LEDs near the field terminal connector of the module indicate the logic state that drives each output. Another LED labeled SC turns on if any output attempts to drive a short circuit.

The eight point input section converts DC signals from devices into logic levels that the CPU can use. Each signal is converted into a corresponding logic 1 or 0 which is transmitted through the communication interface to the CPU module. An "on" signal is nominally 24 VDC, but can be any level between 15 and 30 volts. An "off" signal is any level below 5V. The wiring configurations may be sink or source. Eight LEDs near the field terminal connector of the module indicate the logic state of each input.

Figure 5-1 Block 24V DC Output/Input Module (8/8 Point)

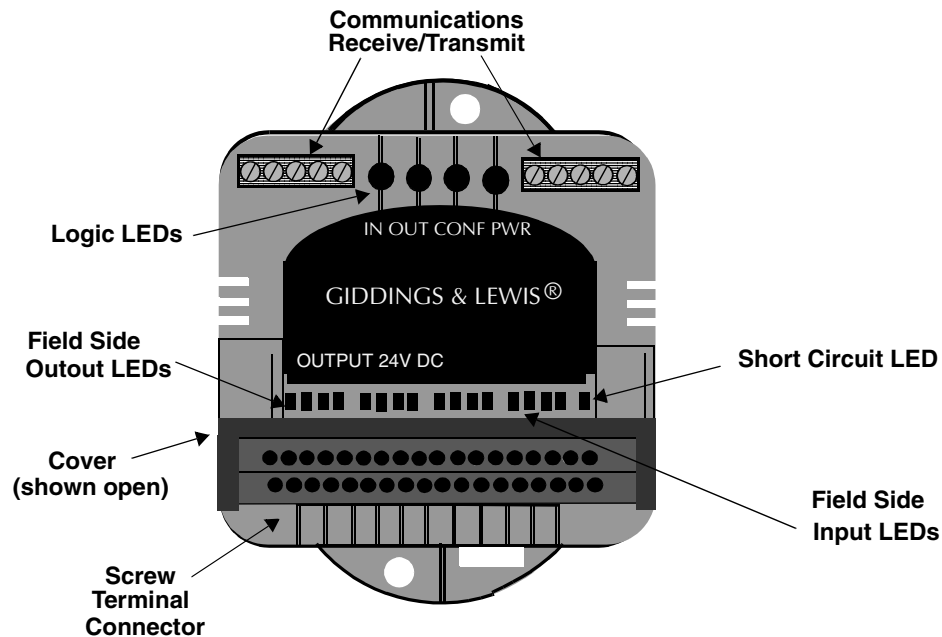

5.2 Connections

A screw terminal connection is provided for each output, input, and external power supply connection. The group of eight outputs and the group of eight inputs are isolated. The output group has its own short circuit protection with a short circuit LED indicator. The input group has additional terminal connections for the DC sink/source configuration.

The external DC supply that powers the output and/or input signals should have a wire connected from its 0V (COMMON) terminal directly to the single point ground used for the system rack.

Figure 5-2 Screw Terminal Connection Assignments

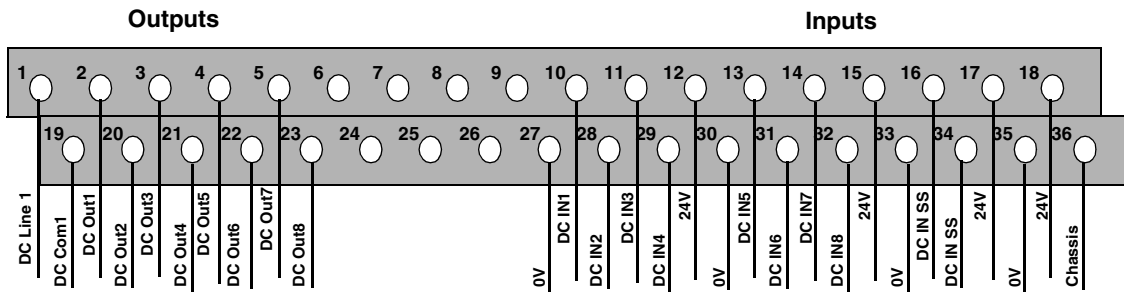

Typically, an external 24V DC supply is connected to pins 18 and 35. These pins are internally jumpered so that the supply is available at the other pins labeled as 24V and 0V. This makes it convenient to connect a 3-wire device (i.e., a proximity switch) which requires a voltage and ground connection. Also, 24V or 0V can be easily jumpered to the input sink/source connection.

Connections for the outputs are illustrated in Figure 5-3.

The common side of each load must be connected to the 0V terminal of the supply. This 0V terminal is connected to the SPG used by the system rack.

Use up to 14 AWG for field side wiring.

Figure 5-3 Connections for the Outputs

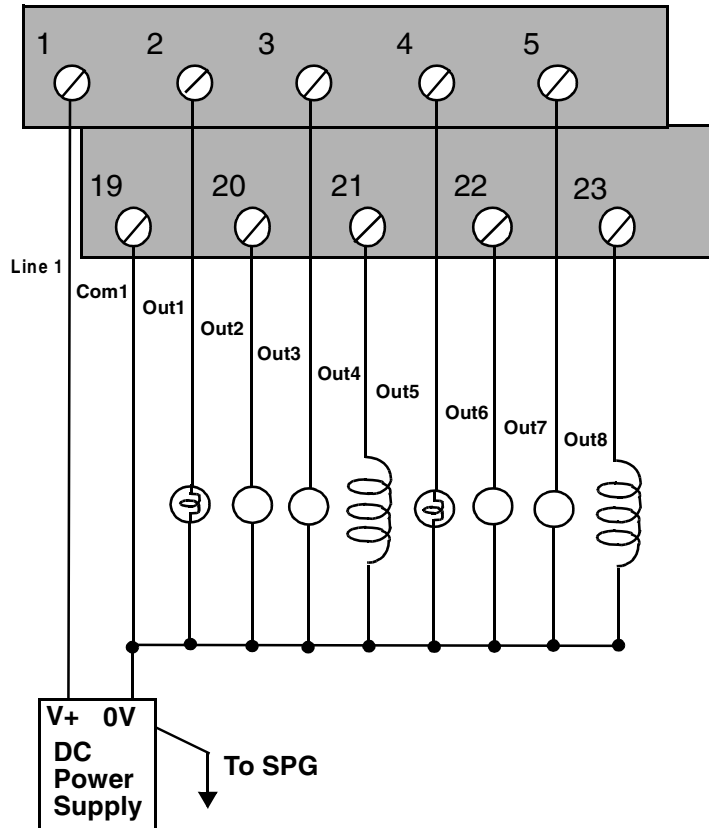

Connections for the inputs are illustrated in Figure Figure 5-4.

The eight inputs on the left are shown with devices "sourcing" current through the block module. The COMMON terminal of the power supply is connected internally to the module by the jumper between 0V and the DC IN SS.

The eight inputs in the example on the right are shown with devices "sinking" current through the block module. The HOT terminal of the power supply is connected internally to the module by the jumper between 24V and DC IN SS.

Use up to 14 AWG for field side wiring.

Figure 5-4 Connectors for Inputs

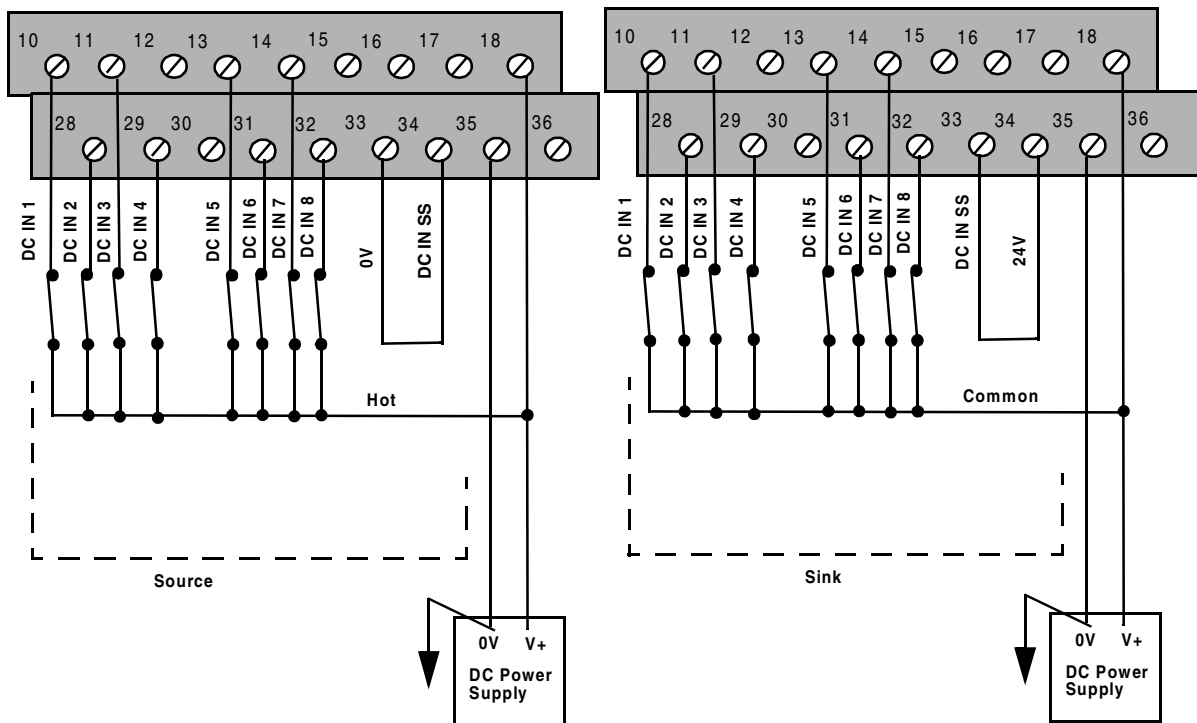

5.2.1 Communications Connections

There are two 5-pin communications connectors and four logic LEDs on the top of the block I/O module as shown in Figure 5-5.

Figure 5-5 Pinouts for Communication Connectors

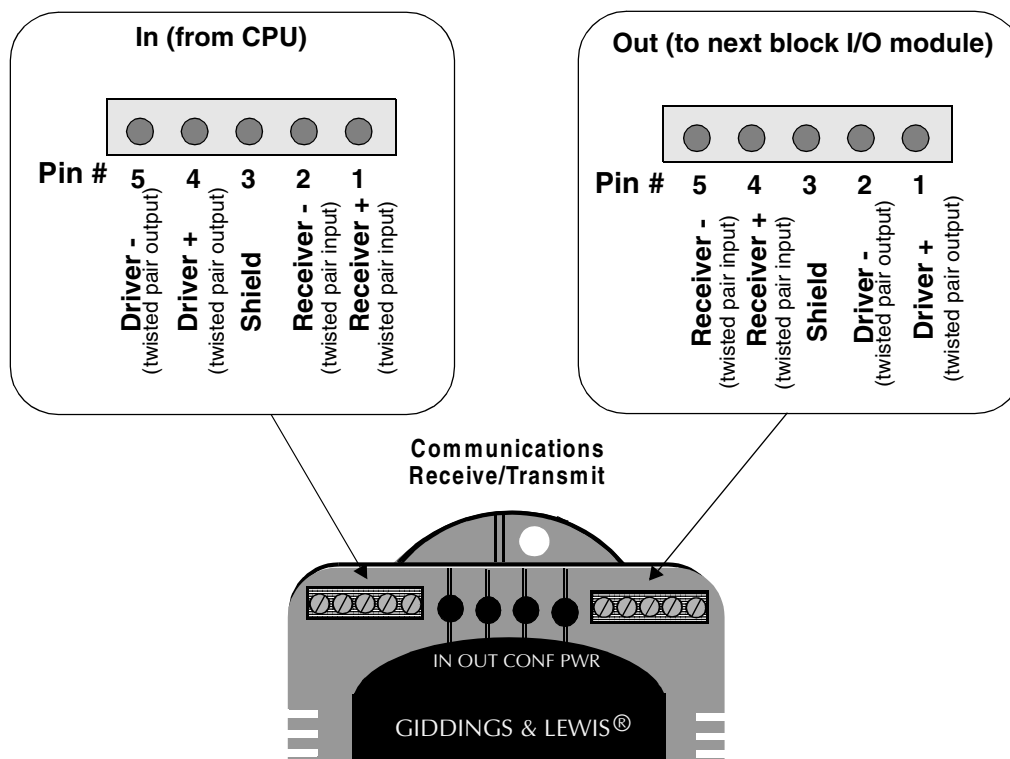

5.2.1.1 LEDs

LED	Color	State	Definition
DATA IN	Yellow	FAINT	Data being passed through the block module
		BRIGHT or OFF	No activity through the block module
DATA OUT	Yellow	FAINT	Data is being passed through the block module
		BRIGHT or OFF	No activity through the block module
CONFIG	Green	ON	Communication established with this block I/O module
		OFF	Communication not established
PWR	Green	ON	Internal +5V logic power supply OK
		OFF	No external 24V applied or internal 5V logic supply not OK

5.2.2 Protecting from an Inductive Load

Resistive loads can be connected to the module and controlled by the system with no precautions other than making sure they have a connection to the common of the DC power supply.

Inductive loads have an electrical "kickback" when current is stopped. This can damage or destroy the output switching device. Each output in the Output 24V DC module has a diode through which reverse current can be safely routed.

Figure 5-6 shows how the internal diode works with an inductive load. When an output is energized, represented in Figure Figure 5-6a by a closed switch, current passes through the load into the common line. When the output is de-energized, represented in Figure 5-6b by an open switch, current stops and the inductive field collapses. The state of the outputs is controlled by the CPU module. This creates a reverse voltage across the load called "kickback" which tries to continue the current. The voltage is in series with the DC power supply. The combined voltage appears across the output switching device in the module.

If this were the only path available, voltage across the device would peak at several hundred volts. The internal diode provides another path for current. This limits the peak reverse voltage across the load to less than 1 V. Every switch in the Output 24V DC module has this protection so you can connect an inductive load to any terminal.

Figure 5-6 Diagram of Internal Protection for Inductive Loads

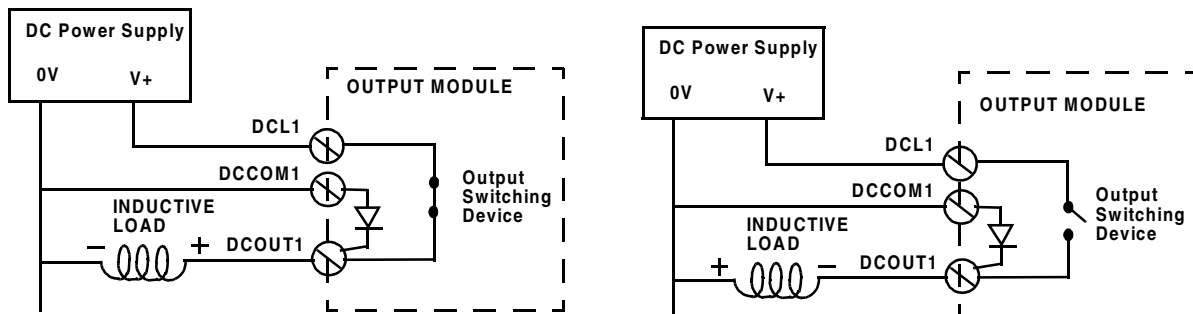

a) Output Energized

b) Output De-energized

5.3 Theory of Operation

5.3.1 Outputs

Each output point is a solid state switch rated at .5 A. It turns on or off according to the logic state sent to it by the CPU. If the CPU sends it a logic 1, the switch closes and the device is powered. If the CPU sends a logic 0, the switch opens and power to the device is cut off. The CPU updates the logic state for each switch every time it scans the program.

The logic side of the switch is optically isolated from the field side. An LED gives the logic state of each switch. If you need to know whether voltage is actually present at the field side, use a voltmeter on the terminal screws.

The group of outputs has a .1 ohm series sensing resistor to protect against current overload in case the outputs are shorted to ground. When a short circuit condition is sensed, all outputs are pulsed on for approximately 130 microseconds every 100 milliseconds. Normal operation resumes after the short is removed. In addition, each output is protected with internal clamping diodes. Without clamping, high voltage transients (kickback) from inductive loads might damage the module.

5.3.2 Inputs

Each input is guaranteed "on" at 15 to 30 VDC and guaranteed "off" at 0 to 5 VDC; polarity doesn't matter. Its on/off state is converted to a corresponding logic 1 or 0. This logic state is transmitted through the communication interface to the CPU module, where the processor uses it as data in the ladder program. The logic side of the input is optically isolated from the field side.

An LED in the upper section of the module indicates the logic state of each input. The group of inputs is represented by a horizontal row of LEDs. If you need to know whether voltage is present at the field side, use a voltmeter on the terminal screws.

The shaded blocks in Figure 5-7 show the limits specified by the IEC. The lines show the maximum and minimum V/I of the inputs in this module. The voltage/current curve in this graph shows that the input module is well within the IEC Type 1 limits.

Figure 5-7 Input Characteristics Compared to IEC Standards

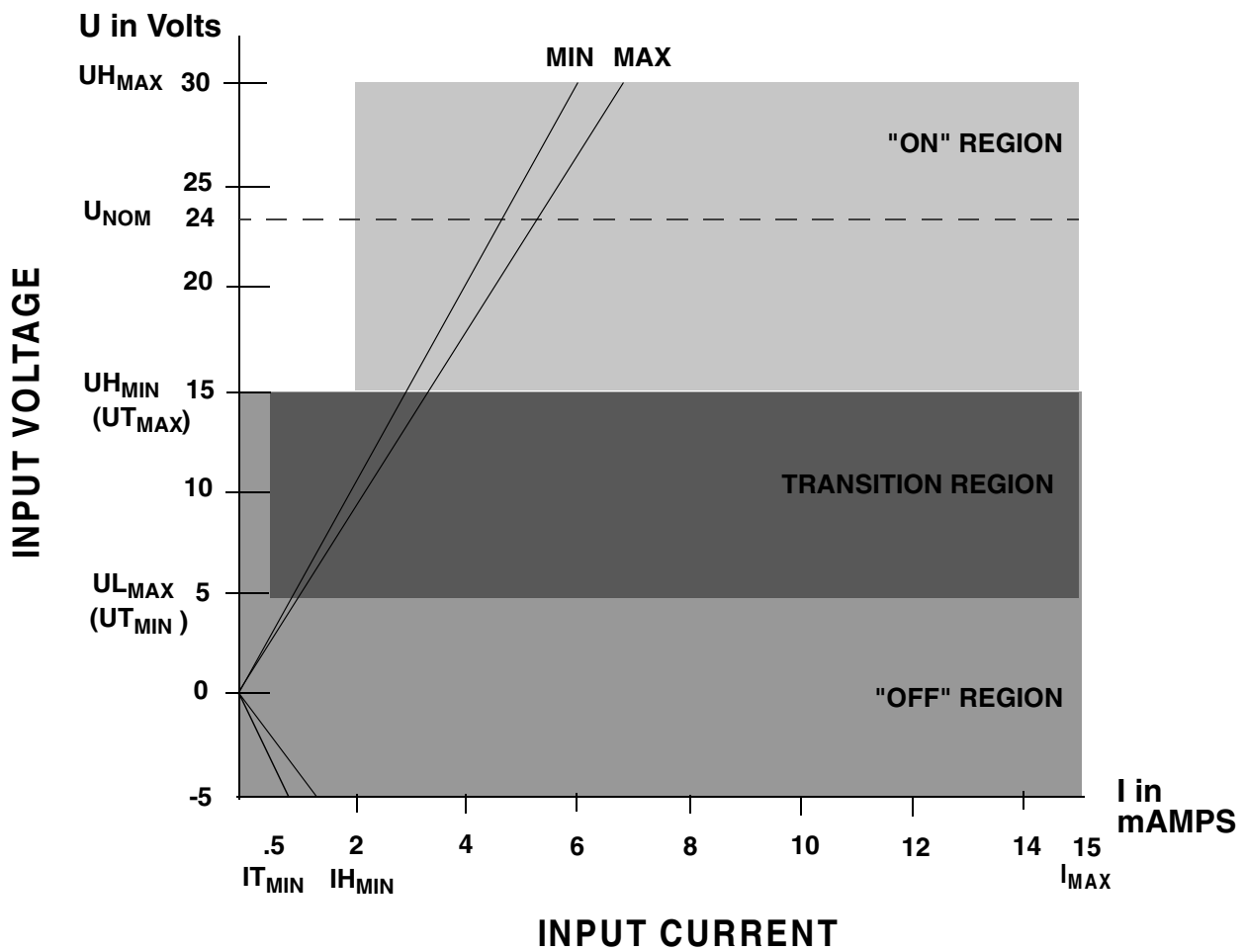

IMPORTANT

Switching devices can sometimes have a leakage current that exceeds the $I_{T_{min}}$ (current allowed when off) of an input module. In order to use such a device, an impedance (typically, a resistor) needs to be used in parallel with the input.

For example, some of the newer proximity switches use two wires instead of three. The third wire was used for a power or ground line. Without the third wire, the switch is easier to install. However, it requires more leakage current in the off state to power its internal circuitry.

As a conservative estimate, use the following formula to calculate an external resistance value. It keeps the input voltage at or below 2.4V when the switching device is in the "off" state.

$$\frac{2.4V}{\text{Switch Leakage} - 0.75mA} \geq R$$

If the switch leakage specification is ≤ 1.7 mA, then:

$$\frac{2.4V}{1.7 - 0.75mA} \geq 2.5K\Omega$$

Use a resistor less than or equal to 2.5 K Ω . Be sure that the wattage is adequate for the resistor when the switching device is in the "on" state remembering that:

$$P = \frac{V_{ON}^2}{R}$$

5.4 Specification Table

Characteristic	Block 24V DC module (8 In/8Out) specifications
Function	Monitors on/off states from eight DC voltage inputs and sources an external DC supply to eight loads
Part number	M. 1017.3090 (old # 503-25906-01)
Field side connector	Two 18-pin connectors, screw terminals
Protection of logic circuits	Optical isolation between the logic and field sides, transient suppression for the 24V external supply
Logic side LEDs, module status	Data In LED Data Out LED Configured LED Power LED
Logic side LEDs, input status	A yellow LED for each input
Logic side LEDs, output status	A yellow LED for each output
Logic side LED, short circuit status	A red LED lights to indicate a short circuit condition
Module power requirements	100 mA from an external 24V DC supply (20 to 30V DC range) NOTE: 2.5A, 250 microsecond inrush at power on
CE Marked	<p>Conforms to Directives 73/23/EEC, 89/336/EEC, 92/31/EEC, 93/68/EEC by conforming to the following standards:</p> <p>EN 50081-2:1993 EMC Generic Industrial Emissions EN 50082-2:1995 EMC Generic Industrial Immunity EN 61131-2:1994/A11:1996 Low voltage directive requirements for programmable controllers</p> <p>Operates with emissions below EN55011/ CISPR 11 Class A limits</p> <p>Immune to:</p> <ul style="list-style-type: none"> • Electrostatic discharge (4K V contact mode, 8K V air discharge) per EN61000-4-2 • RF electromagnetic fields per EN61000-4-3, ENV 50141, and ENV50204 • Electrical fast transients per EN61000-4-4 • Magnetic fields per EN61000-4-8 <p>Refer to the EMC Guidelines for more information.</p>
UL and C/UL Listed	File No. E126417 NRAQ Programmable Controllers
Operating temperature range	7° C to 55° C (45° F to 131° F)
Storage temperature range	-40° C to 85° C (-40° F to 185° F)
Humidity	5 to 95%, non-condensing

Physical size	4.05" wide x 4.825" high x 3" deep 102.9 mm x 122.6 mm x 76.2 mm
UL Listing and CE Marking	In process
Input Section	
Input signals	Nominal 24 VDC on, 0 VDC off, conforming to IEC Type 1 inputs per IEC 1131-2
UH Max (max. allowed voltage)	30 VDC
IH Max (max. current @ 30 VDC)	7.5 mA
UL Min	Polarity independent
Guaranteed on	15 VDC
IH Min (min. current @ UH Min)	2.8 mA
Guaranteed off	5 VDC
IT Min (current allowed when off)	.75 mA
Time delay on	1 ms max.
Time delay off	1 ms max.
Output Section	
DC source requirements	Nominal 24V DC; range 20 to 30V DC
Output group	One group of eight solid-state switches. The group uses an external DC supply. It must be referenced to SPG.
Short circuit protection for the group	Pulses output for about 130 μ sec every 100 msec until short is removed
Maximum current per group	4 A of continuous current for the group; each switch is rated at .5 A continuous
Switch characteristics	Solid-state switches
Time delay on for resistive loads	50 μ sec max
Time delay off for resistive loads	50 μ sec max
Leakage current in off state	0.5 mA max
Switch voltage, maximum ON	1 VDC max
Surge current, maximum	25 A for about 130 μ sec every 100 msec
Response to scan loss	All outputs are reset to the OFF state
Vibration (per IEC 68-2-6)	10-57 Hz (constant amplitude .15 mm) 57 - 2000 Hz (acceleration 2 g)
Shock (per IEC 68-2-27)	Four shocks per axis (15g/11 msec)

NOTES

6 Block Output 120V AC Module (8 points)

6.1 Introduction

The 120V AC block output module switches voltage for eight individual loads from one or two AC power sources. Each external AC source is nominally 115VAC, but can be between 48 and 138 volts.

8 LEDs in the lower section of the module indicate the logic state that drives each output. Another LED labeled SC turns on if the AC power is not connected.

Figure 6-1. Block Output 120V AC Source Module (8 points)

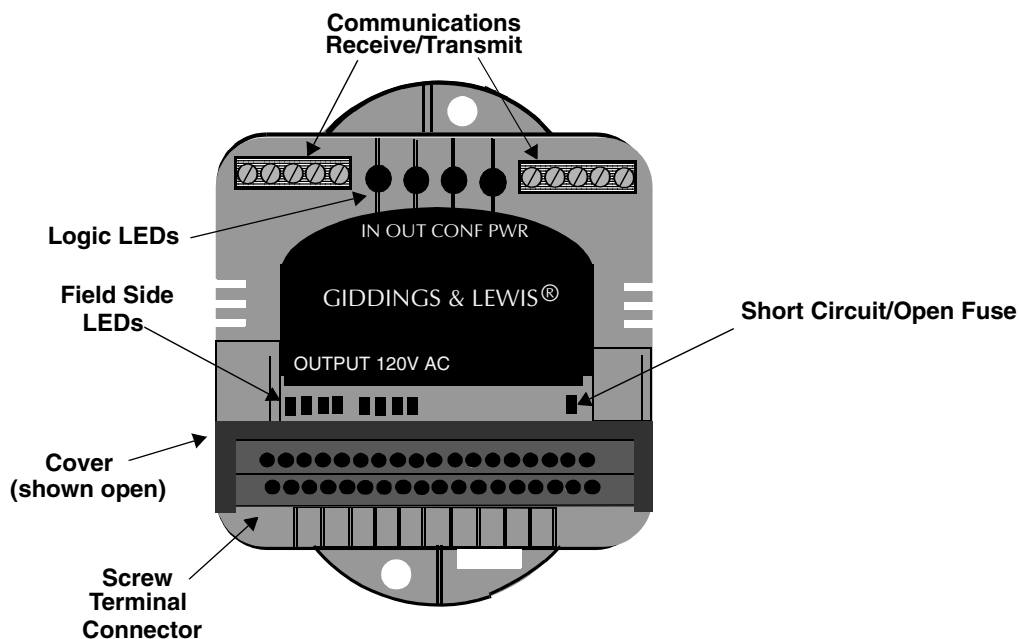

6.2 Connections

A screw terminal is provided for each output and for power connections. The outputs are optically isolated and separated into two groups of four. The external devices in each group must use the same power source. The outputs must not be paralleled or tied together.

The power to operate the module is brought in through pins 12 and 23, +24 volt and 24 volt COM, respectively. Pin 24 Chassis GND need not be connected if the block is DIN rail mounted.

Figure 6-2. Screw Terminal Connections

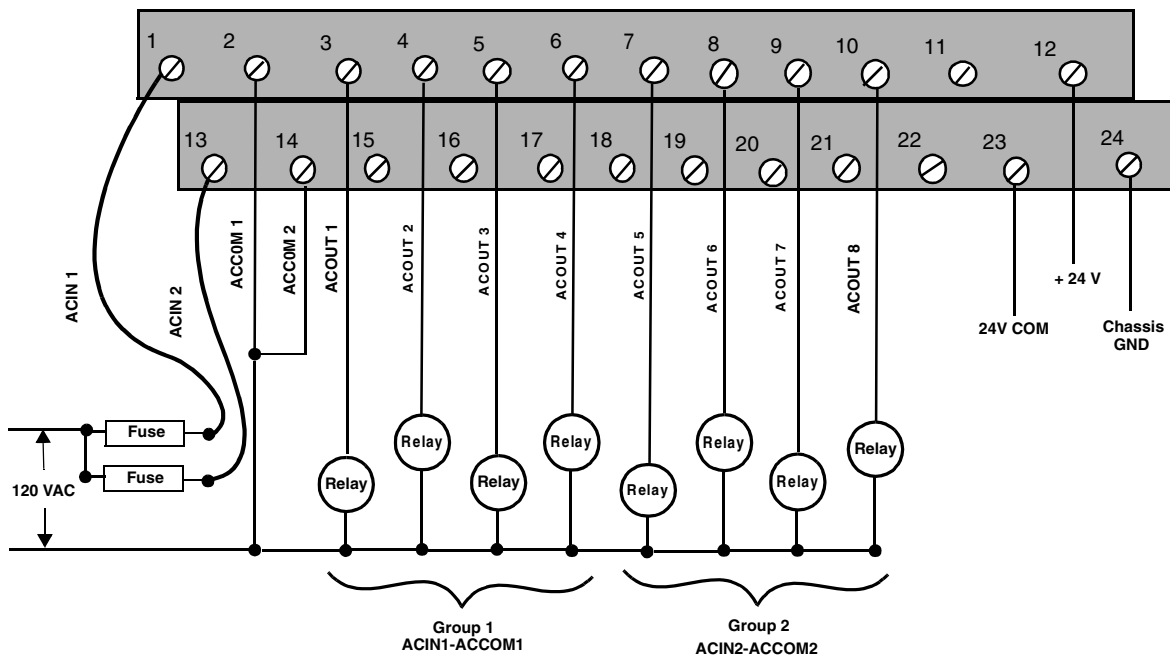

NOTE

To conform to CE requirements for a positive earth connection, connect a 6 inch (or less) #14 AWG (2 mm wire) from the chassis pin to earth.

6.2.1 Fusing

External fuses are required (see fusing recommendations) and each of the two AC inputs should be fused separately unless current requirements are less than 3 amps total.

6.2.1.1 Fuse Monitor

If AC power is disrupted to the unit, a short circuit/blown fuse LED indicator will be lit and a software monitoring bit will be enabled in the block I/O data message.

For the fuse monitor to work correctly when only the first block of 4 outputs is used, jumper ACIN1 to ACIN2 and ACCOM1 to ACCOM2.

6.2.2 Communications Connections

There are two 5-pin communications connectors and four logic LEDs on the top of the block I/O module as shown in Figure 6-3.

Figure 6-3. Pinouts for Communication Connectors

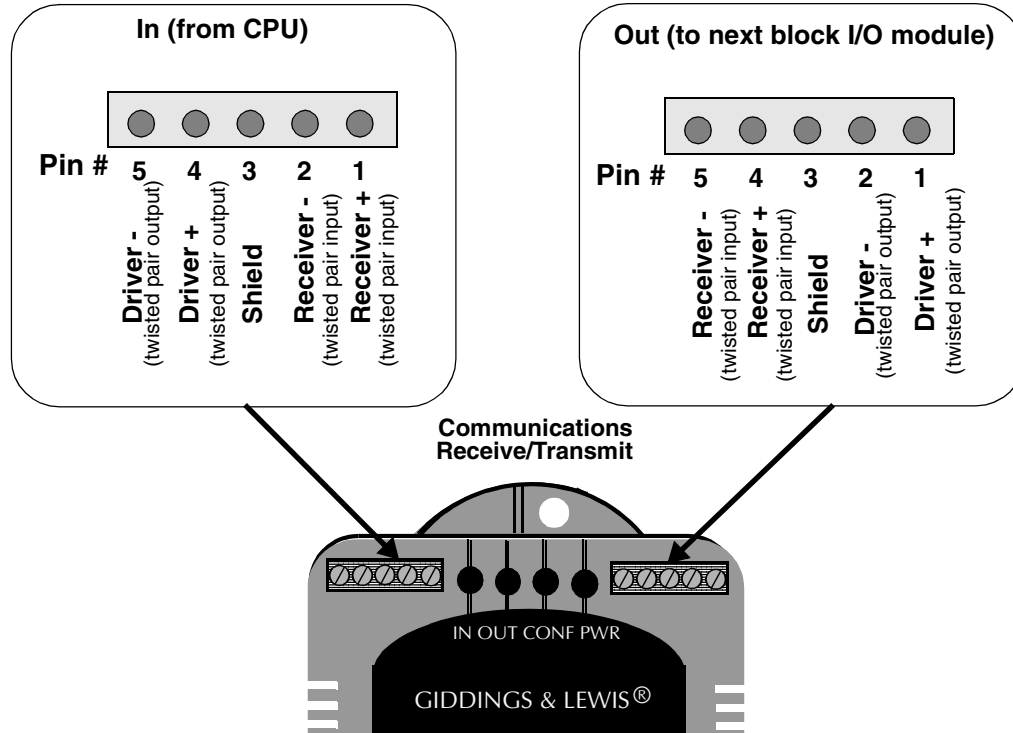

6.2.2.1 LEDs

LED	Color	State	Definition
DATA IN	Yellow	FAINT	Data being passed through the block module
		BRIGHT or OFF	No activity through the block module
DATA OUT	Yellow	FAINT	Data is being passed through the block module
		BRIGHT or OFF	No activity through the block module
CONFIG	Green	ON	Communication established with this block I/O module
		OFF	Communication not established
PWR	Green	ON	Internal +5V logic power supply OK
		OFF	No external 24V applied or internal 5V logic supply not OK

6.2.3 Protecting from an Inductive Load

Arc suppression is not required for a non-inductive load or for an inductive load switched only by the Output 120V AC module.

6.3 Theory of Operation

Each output point is a solid state switch rated at .75A continuous for the 8 point module. It turns on or off according to the logic state sent to it by the CPU. If the CPU sends it a logic 1, the switch closes and the load is powered. If the CPU sends a logic 0, the switch opens and power to the load is removed. The CPU updates the logic state for each switch every time it scans the program.

The logic side of the switch is optically isolated from the field side. An LED gives the logic state of each output. If you need to know whether voltage is actually on at the field side, use a voltmeter on the terminal screws.

The output switch is turned on near the zero voltage crossing of the AC power source and is turned off at zero current.

Each group requires an external fuse in series with the source to protect against current overload in case the outputs are shorted to ground.

6.4 Specification Table

Characteristic	BlockOutput 120V AC module (8 Point)
Function	Switches an external AC source to 8 loads
Part number	M.1017.4299 (old # 503-26898-00)
AC source requirements	Nominal 115 VAC, range 48 to 138 VAC
Field side connector	Two 12-pin connectors, screw terminals
Protection of logic circuits	Optical isolation between the logic and field side; Transient protection on outputs.
Arrangement of outputs	Two groups of 4 solid-state switches. Each group can use its own AC source, or one source can be daisy-chained. UL 508 spacing
Fuse per group of 4	Fast-acting, UL rated 3A
Maximum current per group	2A of continuous current for the group; 4 points each switch is rated at .75 A continuous
Indicator lights, output circuits	An LED for each output
Indicator light, module	A DIAG LED turns OFF when the module passes its diagnostic tests at power-on.
Indicator light, fuses	A logic side LED lights to indicate a condition when power to a group is missing or has an open fuse.
Switch characteristics	Solid-state switches.
Switch voltage, maximum ON	1V AC @ .75A RMS
Surge current, maximum	20 A for 2 cycles, every 2 seconds; fuse blows if this is exceeded.
Frequency	50 / 60 Hz. $\pm 5\%$
Time delay on, maximum	1/2 cycle (turns on at zero voltage)
Time delay off, maximum	1/2 cycle (turns off at zero voltage)
Minimum load current	50 mA
Leakage current in OFF state, maximum	4 mA @ 120 VAC
Logic side LEDs, module status	Data In LED Data Out LED Configured LED Power LED
Logic side LEDs, input circuits	A yellow LED for each input

Module power requirements	120 mA from an external 24V DC supply (20 to 30V DC range) NOTE: 2.5A, 250 microsecond inrush at power on
CE Marked(Pending)	Conforms to Directives 73/23/EEC, 89/336/EEC, 92/31/EEC, 93/68/EEC by conforming to the following standards: EN 50081-2:1993 EMC Generic Industrial Emissions EN 50082-2:1995 EMC Generic Industrial Immunity EN 61131-2:1994/A11:1996 Low voltage directive requirements for programmable controllers Operates with emissions below EN55011/ CISPR 11 Class A limits Immune to: <ul style="list-style-type: none"> • Electrostatic discharge (4K V contact mode, 8K V air discharge) per EN61000-4-2 • RF electromagnetic fields per EN61000-4-3, ENV 50141, and ENV50204 • Electrical fast transients per EN61000-4-4 • Magnetic fields per EN61000-4-8 Refer to the EMC Guidelines for more information.
UL and C/UL Listed (Pending)	
Operating temperature range	7° C to 55° C (45° F to 131° F) *
Storage temperature range	-40° C to 85° C (-40° F to 185° F)
Humidity	5 to 95%, non-condensing
Physical size	4.05" wide x 4.825" high x 3" deep 102.9 mm x 122.6 mm x 76.2 mm
Vibration (per IEC 68-2-6)	10-57 Hz (constant amplitude .15 mm) 57 - 2000 Hz (acceleration 2 g)
Shock (per IEC 68-2-27) (Pending)	Four shocks per axis (15g/11 msec)

NOTES

7 Block Relay Module (8 points)

7.1 Introduction

The relay output module can switch eight relay contacts. Four relays are normally open(NO)/normally closed(NC) form C type and four are normally open (NO) form A type.

Eight LEDs in the upper section of the module indicate the logic state that drives each relay.

Figure 7-1 Block Relay Module (8 Point)

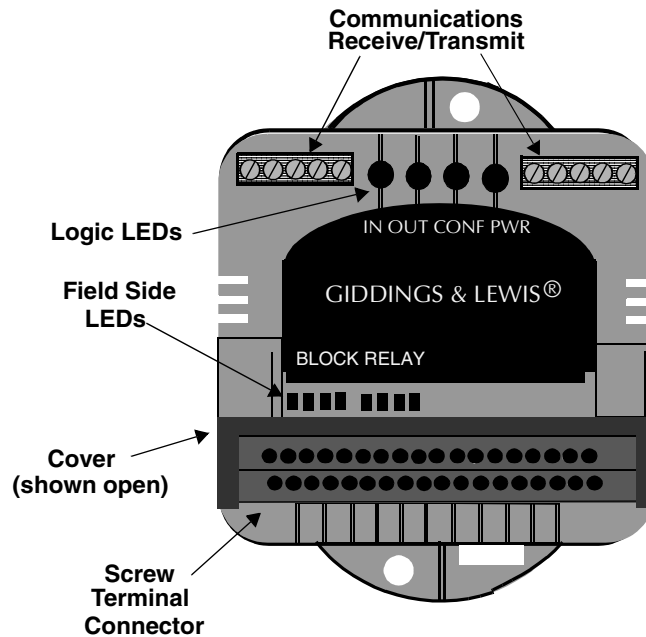

7.2 Connections

A screw terminal connection is provided for each side of the contact. The form C type has three connections; normally open (NO), normally closed (NC), and the common terminal (CT). Only two of the connections can be wired at any time. The common terminal connection must be wired with either the normally open or the normally closed connection depending on the application.

The form A type has two connections; one for each side of the contact.

Figure 7-2 Screw Terminal Connector Assignments

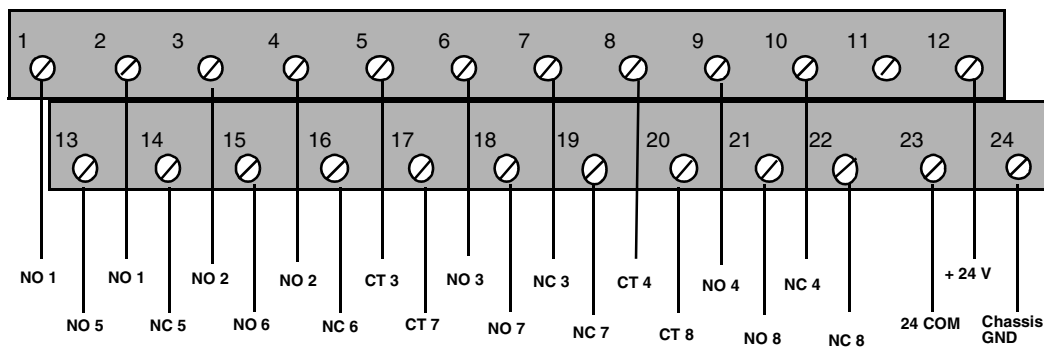

NOTE

To conform to CE requirements for a positive earth connection, connect a 6 inch (or less) #14 AWG (2 mm wire) from the chassis pin to earth.

7.2.1 Normally Open Contact Form C Type

If the normally open contact of the form C type is required for the application, wire as shown in Figure 7-3

Figure 7-3 Connections for Form C Normally Open

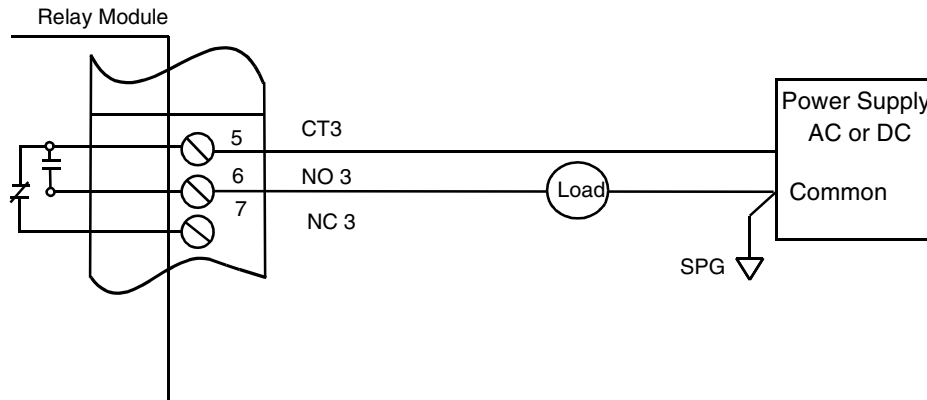

7.2.2 Normally Closed Contact Form C Type

If the normally closed contact of the form C type is required for the application, wire as shown in Figure 7-4.

Figure 7-4 Connections for Form C Normally Closed

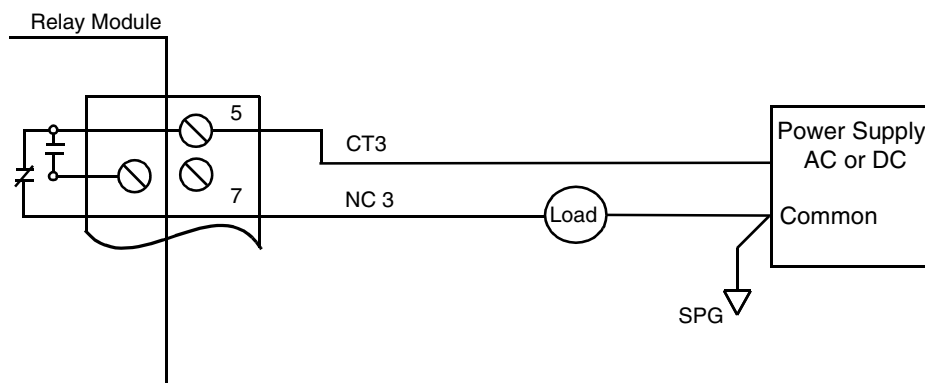

7.2.3 Normally Open Contact Form A Type

To wire the normally open contact of form A, refer to Figure 7-5.

Figure 7-5 Connections for Form A Normally Open

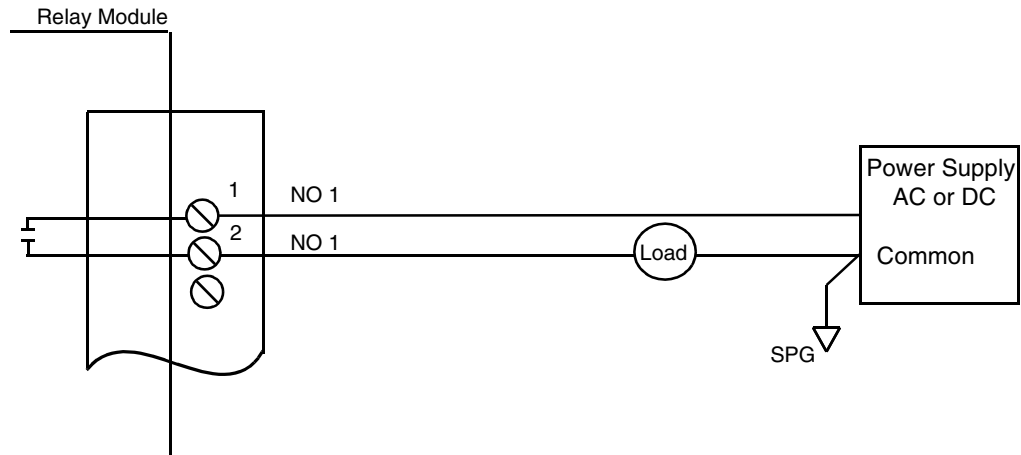

7.2.4 Contact Noise Suppression

All inductive loads should be noise suppressed. They should include motors, relay coils, solenoids etc. Resistive loads need not be suppressed such as lamps, heating elements etc. The suppression will reduce the system electrical noise and contribute to system longevity and reliability.

DC suppression is usually a diode or zener across the coil as shown in Figure 7-6. The diode will increase the time for the relay to de-energize. If this is a problem a zener or similar device may be used.

Figure 7-6 DC Suppression Example

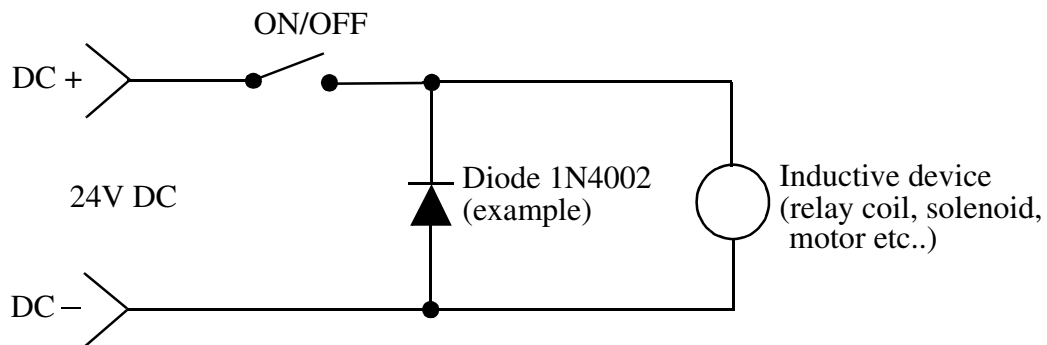

AC suppression is usually done with an RC network across the inductive device. Examples of AC inductive suppression are shown in Figure 7-7.

Figure 7-7 AC Suppression Example

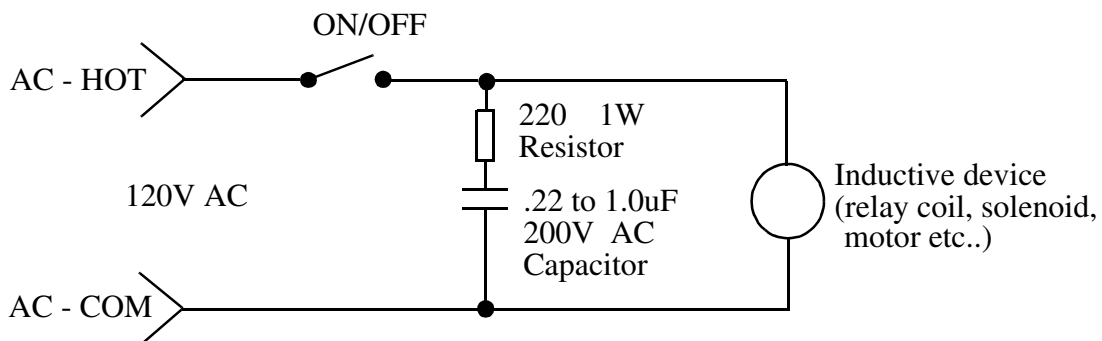

7.2.5 Communications Connections

There are two 5-pin communications connectors and four logic LEDs on the top of the block I/O module as shown in Figure 7-8.

Figure 7-8 Pinouts for Communication Connectors

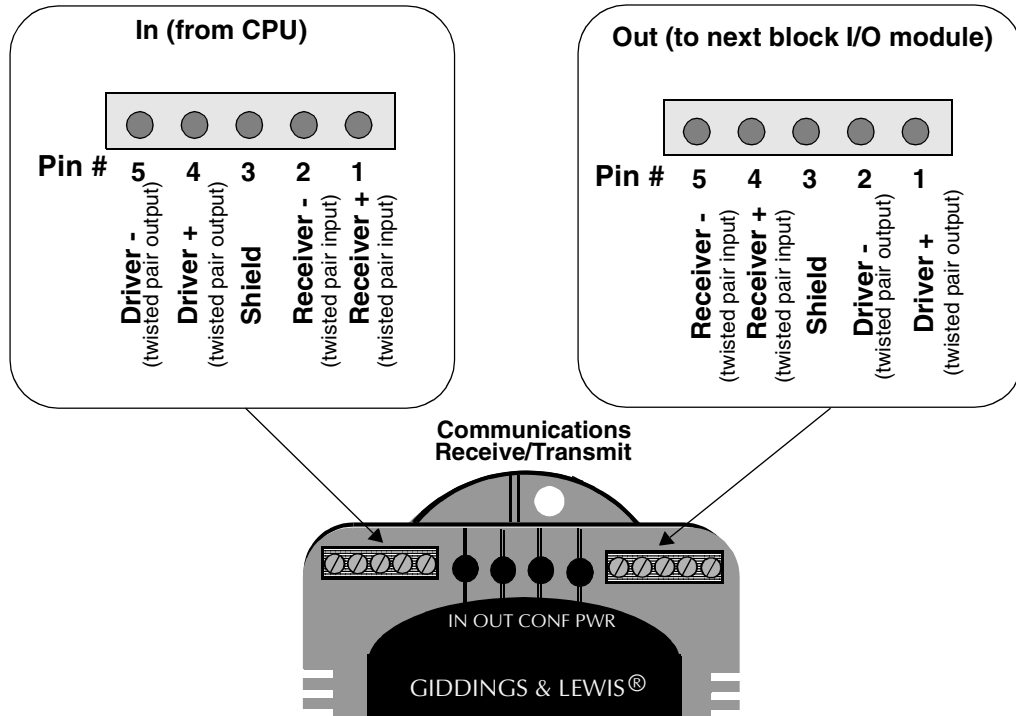

7.2.5.1 LEDs

LED	Color	State	Definition
DATA IN	Yellow	FAINT	Data being passed through the block module
		BRIGHT or OFF	No activity through the block module
DATA OUT	Yellow	FAINT	Data is being passed through the block module
		BRIGHT or OFF	No activity through the block module
CONFIG	Green	ON	Communication established with this block I/O module
		OFF	Communication not established
PWR	Green	ON	Internal +5V logic power supply OK
		OFF	No external 24V applied or internal 5V logic supply not OK

7.3 Theory of Operation

A relay is composed of a coil and a set of contacts. When current is passed through the coil, the relay is energized. When no current flows through the coil, the relay is de-energized. The contacts close or open depending on the state of the coil. When the contacts are closed, current can pass through them. When the contacts are open, no current passes.

There are three configurations for contacts referred to as form A, B and C as illustrated in Figure 7-9. The relay output module has form A and form C available.

Figure 7-9 Relay Forms A, B, and C

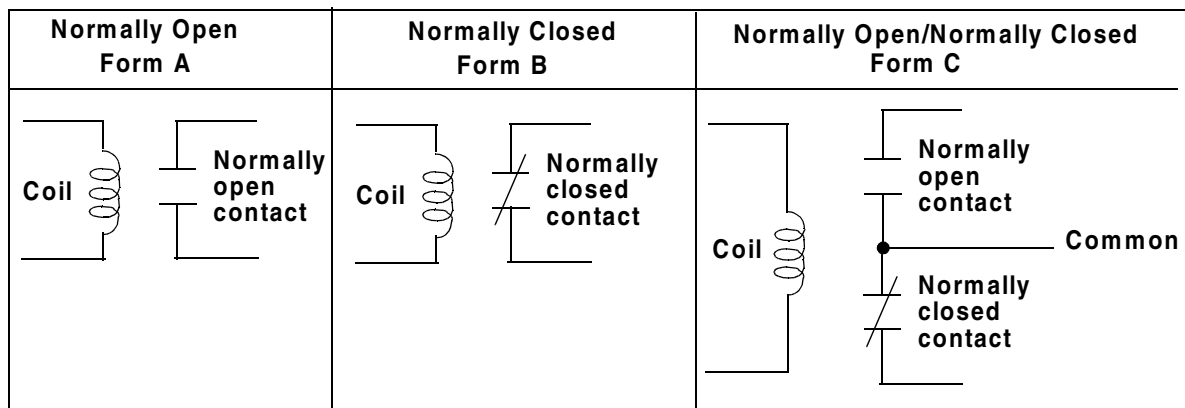

A relay is energized or de-energized according to the logic state sent to it by the CPU. If the CPU sends a logic 1, the relay is energized. If the CPU sends a logic 0, the relay is de-energized. The logic state for each relay is updated every time the CPU scans the ladder program.

The names of the two types of contacts, normally open and normally closed, reflect the state of the contacts when the coil is de-energized. For example, a normally open contact will not pass current when the coil is de-energized. If the coil is energized, the contacts close and current will pass. The normally closed contact will pass current when the coil is de-energized. If the coil is

energized the contacts open and no current will pass. These states are summarized in Table 6-1

Table 6-1 Summary of NO and NC Relays

	Normally Open	Normally Closed
Energized (LED on)	contacts closed/current flow	contacts open/no current flow
De-energized (LED off)	contacts open/no current flow	contacts closed/current flow

The LED for each output reflects the state of the coil. The LED is on when the coil is energized and off when the coil is de-energized.

7.4 Specification Table

Characteristic	Output relay (8) module specification
Function	Switches eight relay contacts
Part number	M.1017.4300 (old # 503-26899-00)
Field side connector	Two 12 pin connectors, screw terminals
Output channels	4 NO, 4 NO/NC
Relay characteristics Contact types	Four form C (NO/NC) Four form A (NO)
Maximum switching voltage	150 VAC resistive load; 150 VDC resistive load
Minimum switching current	100 mA
Maximum switching power (DC)	200 watts @ 4 Amps maximum
Maximum switching current (AC)	0-120 VAC @ 4 Amps maximum
Initial contact resistance	100 m Ω
Turn on time (resistive load)	6 msec typical
Turn off time (resistive load)	2.5 msec typical
Expected life, electrical	10 ⁵ operations minimum
Expected life, mechanical	10 ⁷ operations minimum
Breakdown voltage between contacts	1000 V _{rms}
Logic side LEDs, module status	Data In LED Data Out LED Configured LED Power LED
Logic side LEDs, input circuits	A yellow LED for each input
Module power requirements	100 mA from an external 24V DC supply (20 to 30V DC range) NOTE: 2.5A, 250 microsecond inrush at power on
EMC Compliant Emissions Noise immunity CE Marked (Pending)	Operates with emissions below EN55011/ CISPR 11 Class A limits Immune to: <ul style="list-style-type: none"> • Electrostatic discharge (4K V contact mode, 8KV air discharge) per NEC 1000-4-2 • RF electromagnetic fields per IEC 1000-4-3 • Electrical fast transients per IEC 1000-4-4 on incoming power lines Refer to the EMC Guidelines for more information.

UL and C/UL Listed	File No. E126417 NRAQ Programmable Controllers
Breakdown voltage between contacts and coil	4000 V _{rms}
Maximum switching frequency	20 energize/de-energize cycles/min. (to satisfy expected life ratings)
Indicator light, module	A logic side LED for each relay turns on when the logic side energizes the relay.
Isolation	Electromechanical relay provides protection between logic and field side
24 Volts power requirements	205 mA max
Operating temperature range	7° C to 55° C (45° F to 131° F) *
Storage temperature range	-40° C to 85° C (-40° F to 185° F)
Humidity	5 to 95%, non-condensing
Physical size	4.05" wide x 4.825" high x 3" deep 102.9 mm x 122.6 mm x 76.2 mm
Vibration (per IEC 68-2-6)	10-57 Hz (constant amplitude .15 mm) 57 - 2000 Hz (acceleration 2 g)
Shock (per IEC 68-2-27) (Pending)	Four shocks per axis (15g/11 msec)

* To conform to temperature specifications, the unit must be mounted vertically.

8 Block Input 120V AC Module (8 points)

8.1 Introduction

The input 120V AC module converts AC signals from 8 devices into logic levels that the CPU can use. Each signal is converted into a corresponding logic 1 or 0 which is transmitted through the system bus to the CPU module. An "on" signal is nominally 120 VAC, but can be any level between 79 and 132 volts. An "off" signal is any level below 20 VAC. The wiring configurations may be sink or source.

8 LEDs in the upper section of the module indicate the logic state of each input. The DIAG LED goes on briefly while the diagnostic tests are running.

Figure 8-1 Block Input 120V AC Module (8 Point)

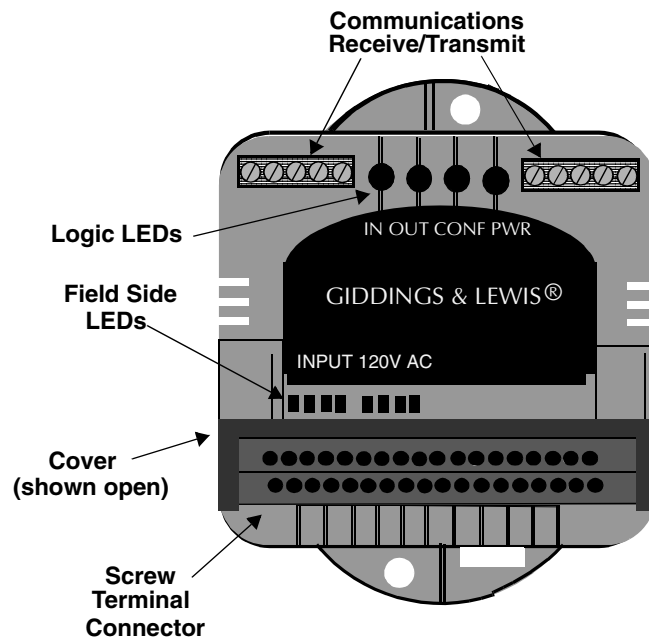

8.2 Connections

A screw terminal is provided for each input and for power connections. The inputs are optically isolated and separated into two groups of four. The external devices in each group must use the same power source, and be wired in the same configuration "sink source". If an external device supplies current to the module it is a source, if it draws from the module it is a sink.

The external pin connections are shown in Figure 8-2.

The power to operate the module are brought in through pins 12 and 23, +24 volt and 24 volt ground, respectively. Pin 24 Chassis ground need not be connected if block is DIN rail mounted (see Note below).

Figure 8-2 Screw Terminal Connection Assignments

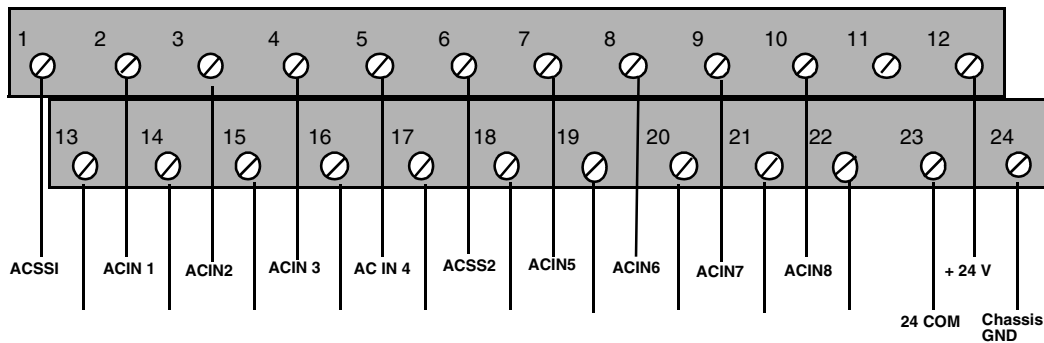

NOTE

To conform to CE requirements for a positive earth connection, connect a 6 inch (or less) #14 AWG (2 mm wire) from the chassis pin to earth.

The power connections ACSSI and ACSS2 are connected to AC common if devices in the group are sources and to 120 VAC if the external devices are sinking. Figure 8-3 shows the first group of four being used as sinking external devices and the second group as sources.

Figure 8-3 Power Connections

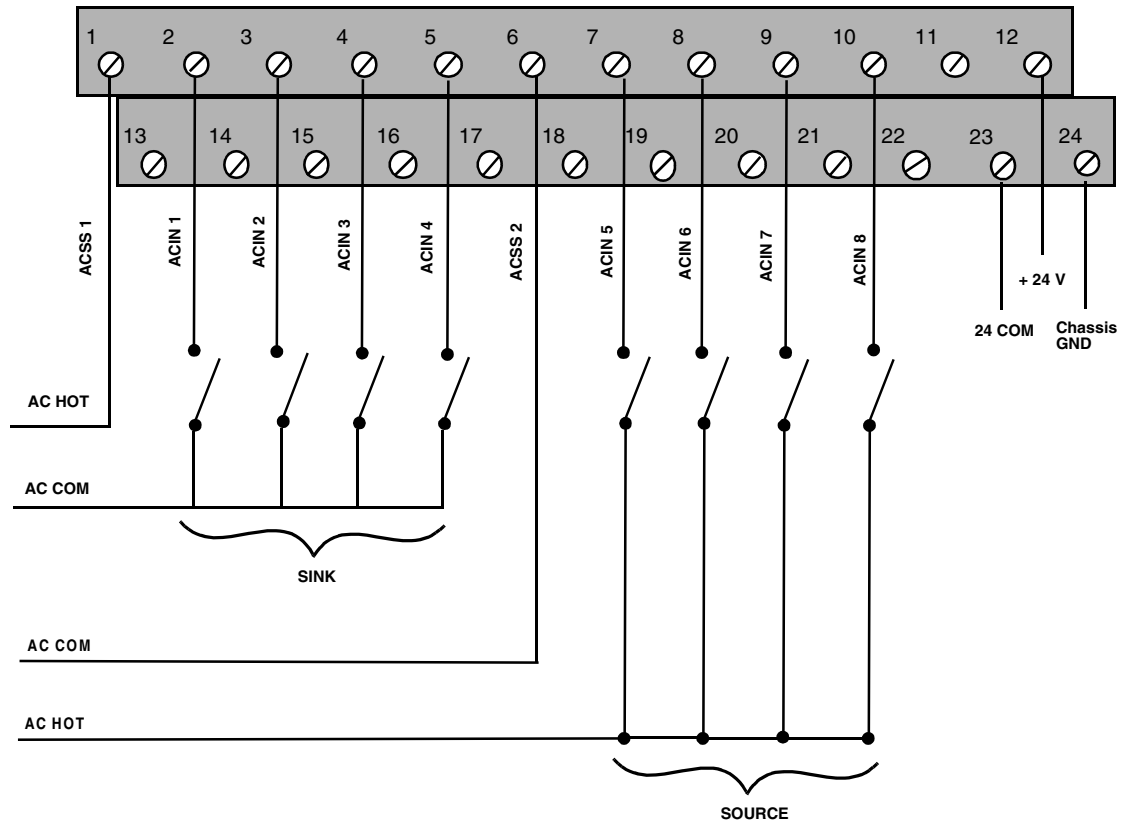

8.2.1 Communications Connections

There are two 5-pin communications connectors and four logic LEDs on the top of the block I/O module as shown in Figure 8-4.

Figure 8-4 Pinouts for Communication Connectors

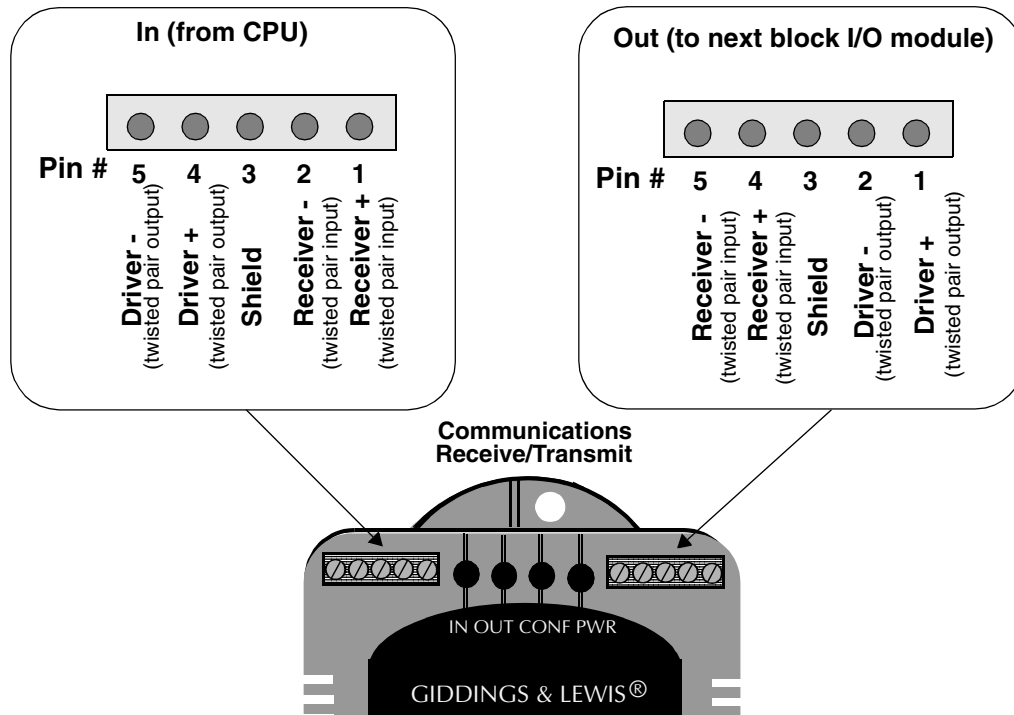

8.2.1.1 LEDs

LED	Color	State	Definition
DATA IN	Yellow	FAINT	Data being passed through the block module
		BRIGHT or OFF	No activity through the block module
DATA OUT	Yellow	FAINT	Data is being passed through the block module
		BRIGHT or OFF	No activity through the block module
CONFIG	Green	ON	Communication established with this block I/O module
		OFF	Communication not established
PWR	Green	ON	Internal +5V logic power supply OK
		OFF	No external 24V applied or internal 5V logic supply not OK

8.3 Theory of Operation

Each input is guaranteed "on" between 79 and 132 VAC and guaranteed "off" between 0 and 20 VAC. Its on/off state is converted to a corresponding logic 1 or 0. This logic state is transmitted through the system bus to the CPU module, where the processor uses it as data in the ladder program. The logic side of the input is optically isolated from the field side.

An LED in the upper section of the module indicates the logic state of each input. The four LEDs representing each group are in a horizontal row. If you need to know the voltage at the field side, use a voltmeter on the terminal screws.

Figure 8-5 shows the input characteristics of the module compared to IEC standards.

The shaded blocks show the limits specified by the IEC, and the lines show the maximum and minimum V/I of the inputs in this module. This voltage/current curve in this graph shows that the AC input module is well within the IEC Type 1 limits.

Figure 8-5 Input Characteristics Compared to IEC Standards

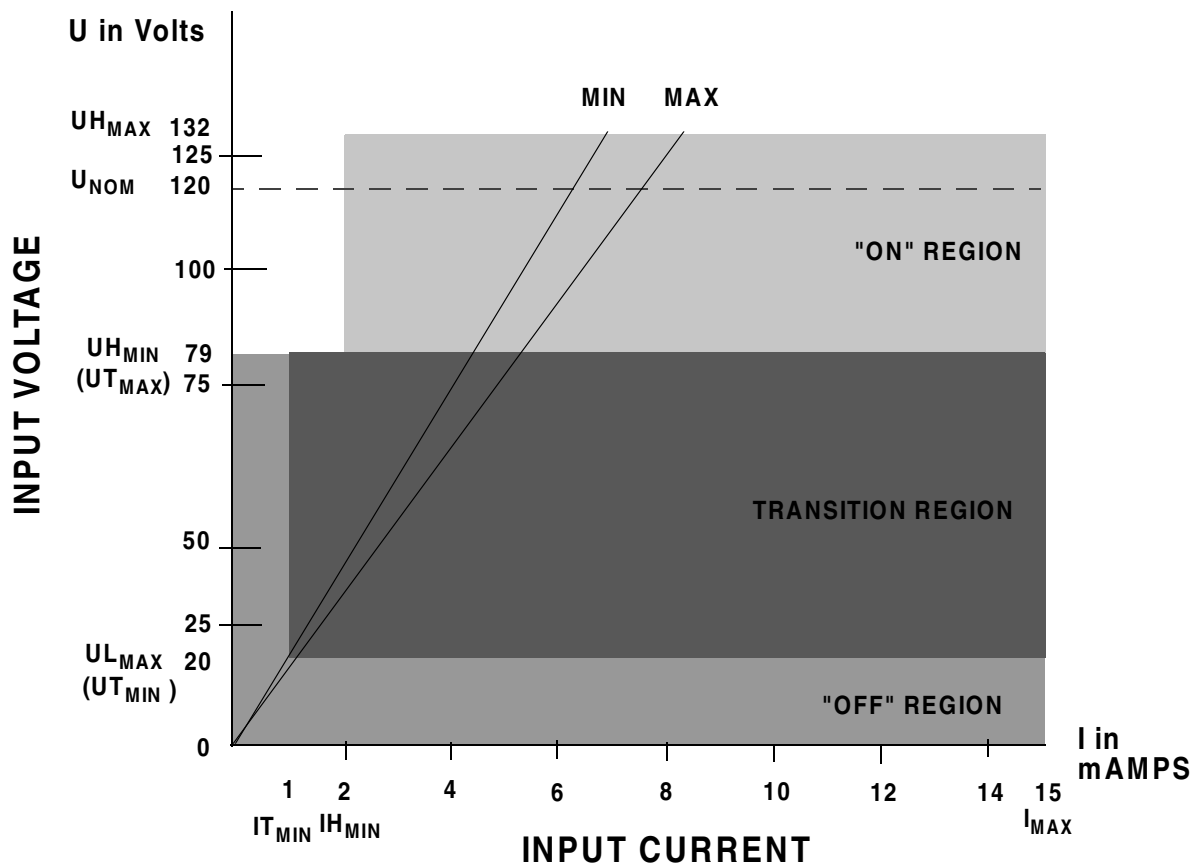

IMPORTANT

Switching devices can sometimes have a leakage current that exceeds the $I_{T_{min}}$ (current allowed when off) of an input module. In order to use such a device, an impedance (typically, a resistor) needs to be used in parallel with the input.

For example, some of the newer proximity switches use two wires instead of three. The third wire was used for a power or ground line. Without the third wire, the switch is easier to install. However, it requires more leakage current in the off state to power its internal circuitry.

As a conservative estimate, use the following formula to calculate an external resistance value. It keeps the input voltage at or below 12V when the switching device is in the "off" state.

$$\frac{12V}{\text{Switch Leakage} - 1mA} \geq R$$

If the switch leakage specification ≤ 1.7 mA, then:

$$\frac{12V}{1.7 - 1mA} \geq 17.1K\Omega$$

Use a 16 K Ω , 2W or any lower resistance and higher wattage resistor. Be sure that the wattage is adequate for the resistor remembering that:

$$P = \frac{V_{rms}^2}{R}$$

It would be acceptable to use a .15 μ F (or greater) capacitor rated for 120V AC. The advantage of the capacitor is minimal power dissipation.

$$X_c = \frac{1}{2\pi fC}$$

8.4 Specification Table

Characteristic	Block Input 120V AC Module
Function	Monitors on/off states from up to 8 AC voltage inputs
Part number	M.1017.4298 (old # 503-26897-00)
Field side connector	Two 12 pin connectors connectors, screw terminals
Input signals	Nominal 120 VAC on, 0 VAC off, conforming to IEC Type 1 inputs per IEC 1131-2 (two groups of four inputs)
UH Max (max. allowed voltage)	132 VAC
IH Max (max. current @ 132 VAC)	8.7 mA
UL Min	0 V
Guaranteed on	79 VAC
IH Min (min. current @ UH Min)	4.6 mA
Guaranteed off	20 VAC
IT Min (current allowed when off)	1 mA
Frequency	50/60 Hz \pm 5%
Time delay on, max.	14 ms
Time delay off, max.	20 ms
Protection of logic circuits	Optical isolation between the logic and field sides, 1780 VAC
Field side power dissipation, worst case	9.2 W

<p>CE Marked (Pending)</p> <p>Pending</p> <p>Pending</p> <p>Pending</p>	<p>Conforms to Directives 73/23/EEC, 89/336/EEC, 92/31/EEC, 93/68/EEC by conforming to the following standards:</p> <p>EN 50081-2:1993 EMC Generic Industrial Emissions EN 50082-2:1995 EMC Generic Industrial Immunity EN 61131-2:1994/A11:1996 Low voltage directive requirements for programmable controllers</p> <p>Operates with emissions below EN55011/ CISPR 11 Class A limits</p> <p>Immune to:</p> <ul style="list-style-type: none"> • Electrostatic discharge (4K V contact mode, 8K V air discharge) per EN61000-4-2 • RF electromagnetic fields per EN61000-4-3, ENV 50141, and ENV50204 • Electrical fast transients per EN61000-4-4 • Magnetic fields per EN61000-4-8 <p>Refer to the EMC Guidelines for more information.</p>
<p>UL and C/UL Listed (Pending)</p>	<p>File No. E126417 NRAQ Programmable Controllers</p>
<p>Operating temperature range</p>	<p>7° C to 55° C (45° F to 131° F) *</p>
<p>Storage temperature range</p>	<p>-40° C to 85° C (-40° F to 185° F)</p>
<p>Humidity</p>	<p>5 to 95%, non-condensing</p>
<p>Physical size</p>	<p>4.05" wide x 4.825" high x 3" deep 102.9 mm x 122.6 mm x 76.2 mm</p>
<p>Vibration (per IEC 68-2-6)</p>	<p>10-57 Hz (constant amplitude .15 mm) 57 - 2000 Hz (acceleration 2 g)</p>
<p>Shock (per IEC 68-2-27) (Pending)</p>	<p>Four shocks per axis (15g/11 msec)</p>

9 Block Input Resolver Module (6 channel)

9.1 Introduction

The block input resolver module can interface to 6 independent resolvers (or equivalent transducers). Feedback information from the resolvers is used to update the on-board memory. The position of each resolver can be read at any time by the PiC.

The module generates two sine waves (RPO and QPO) 90° out of phase with each other and each channel receives a signal whose phase represents the angular position of the resolver. The resolution of the angular position is 4000 counts per revolution or 0.09 degrees.

Figure 9-1 Block Input Resolver Module (6 Channel)

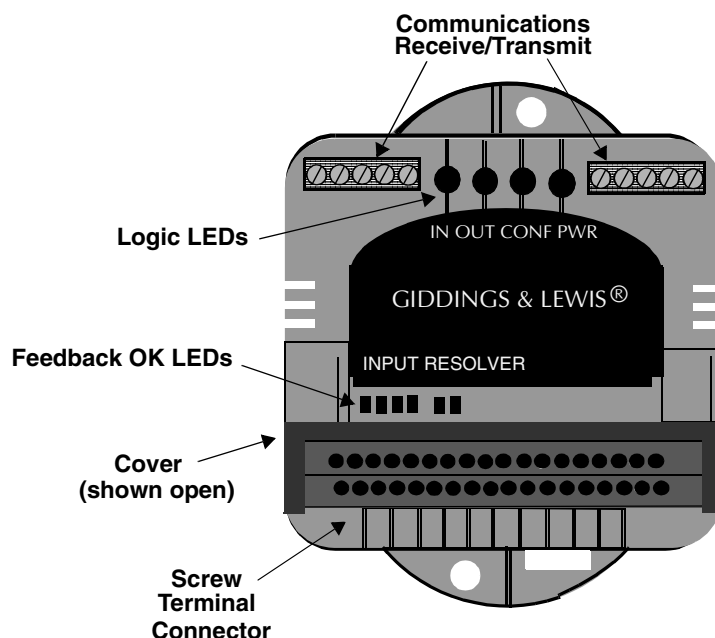

9.2 Connections

Figure 9-2 shows the screw terminal connections for the block input resolver module.

Figure 9-2 Connections for the Block Input Resolver Terminals

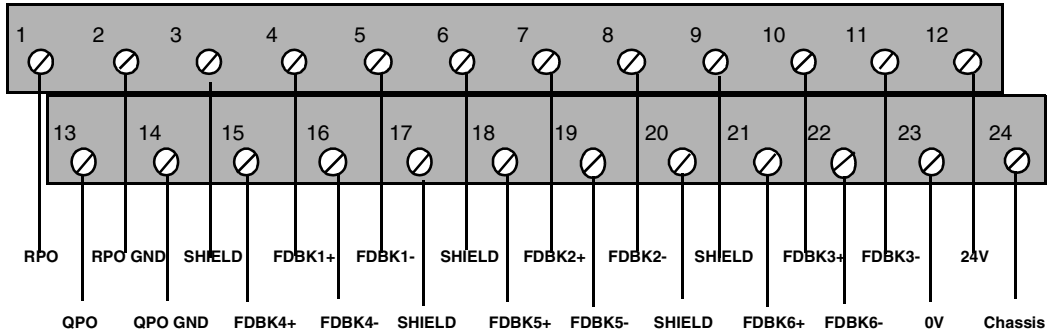

To connect six resolvers to the block resolver module, a user-supplied external terminal block must be used.

Each resolver has three signal pairs. The signals and where they are connected are listed below.

Signal pairs to resolver	Connection
RPO and /shield	To terminal block
QPO and /shield	To terminal block
Signal pair from resolver	Connection
FDBK and /shield	To block input resolver module

All signals from the resolvers must come to the screw terminal connectors (either on the block resolver module or on the terminal block) through shielded twisted pair wires. These wires must be protected against electrical noise because of the speed and/or voltage levels of the signals transmitted through them. The maximum length of the twisted pair wire from the resolver to the terminal block is 100 feet.

The feedback from each resolver is brought back to the appropriate feedback channel connections on the block resolver module. The module has five screw connections for terminating the feedback shields. All are connected inside the module so they are the same point electrically. If all six resolvers are connected, some of the feedback shields will have to be doubled up on the shield connections.

The shields from the RPO and QPO signals are terminated on shield screw connections on the terminal block. The shield at the device end of the cable is not connected.

Figure 9-3 shows how to wire a terminal block and the first resolver. With the terminal block shown, the RPO, QPO, and outputs from the module are each connected to the terminal block. Each is then jumpered so that there are three signals of each type available for the six resolvers (RPO1, RPO2,... QPO1, QPO2,... , etc.).

To connect six resolvers on this terminal block, two connections would be made to the same screw terminal. 18 AWG wire is recommended for these connections. The maximum wire length between the block input resolver module and the terminal block is 6 feet. The feedback signal from the resolver and its shield are wired directly to the module, not the terminal block.

Figure 9-3 Connecting Resolver, Terminal Block, and Module

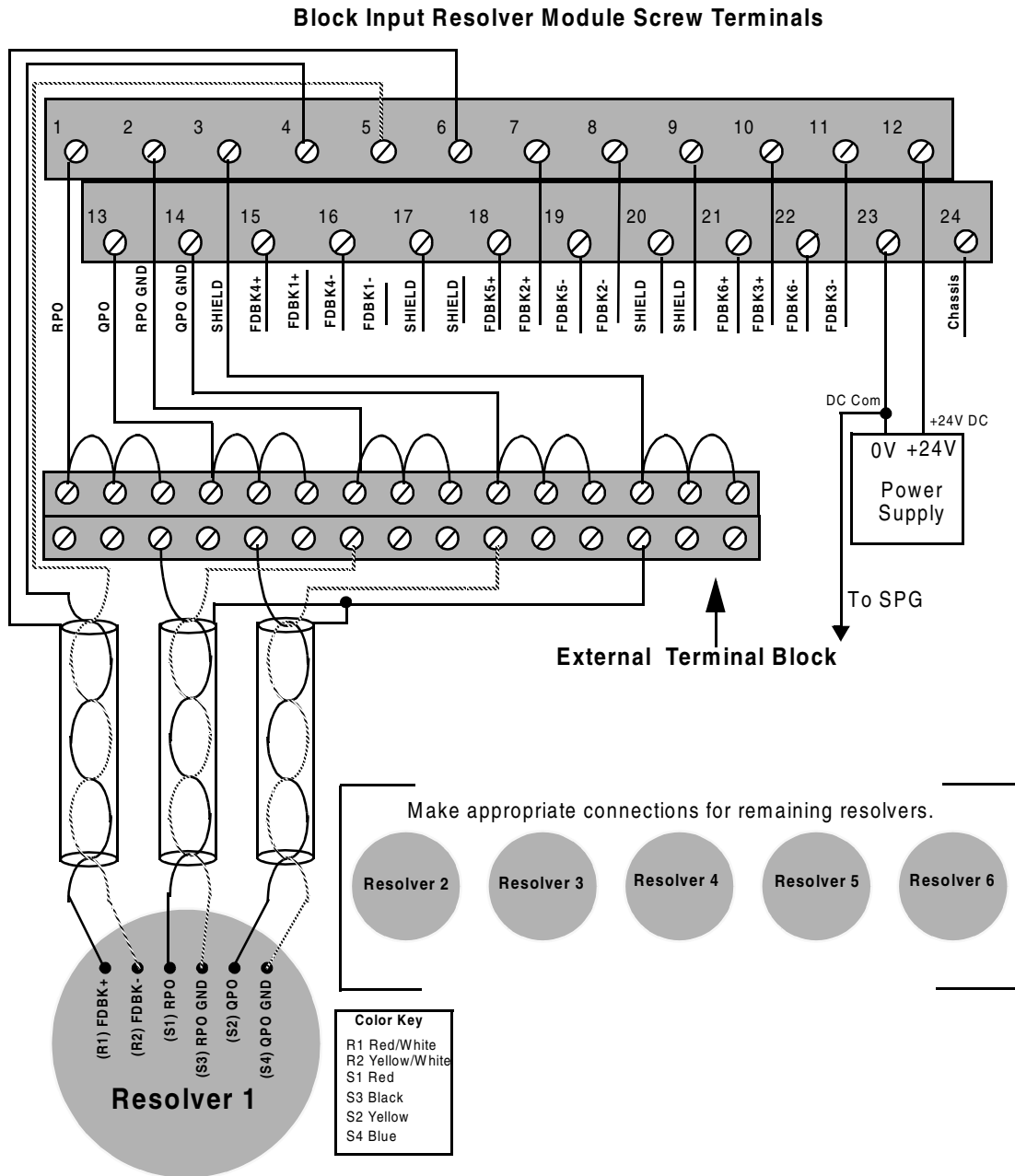

NOTE: If the count direction is incorrect after making the connections (i.e. clockwise rotation is counting down when it should be counting up), swap S1 with S3 or S2 with S4.

9.2.1 Adding an External Potentiometer

External digitizing potentiometers can be connected to the block input resolver module. This can produce a total count deviation of 1000 from full clockwise to full counter-clockwise. Count values will be in the approximate range of 2000 to 3000. Count values will vary from module to module (for example, 2137 to 3137). Therefore, a reference to the value in the full clockwise or full counter-clockwise position should be performed. Figure 9-4 illustrates one potentiometer connected to the block input resolver module through the external terminal strip.

Figure 9-4 Potentiometer Connected to the Block Input Resolver

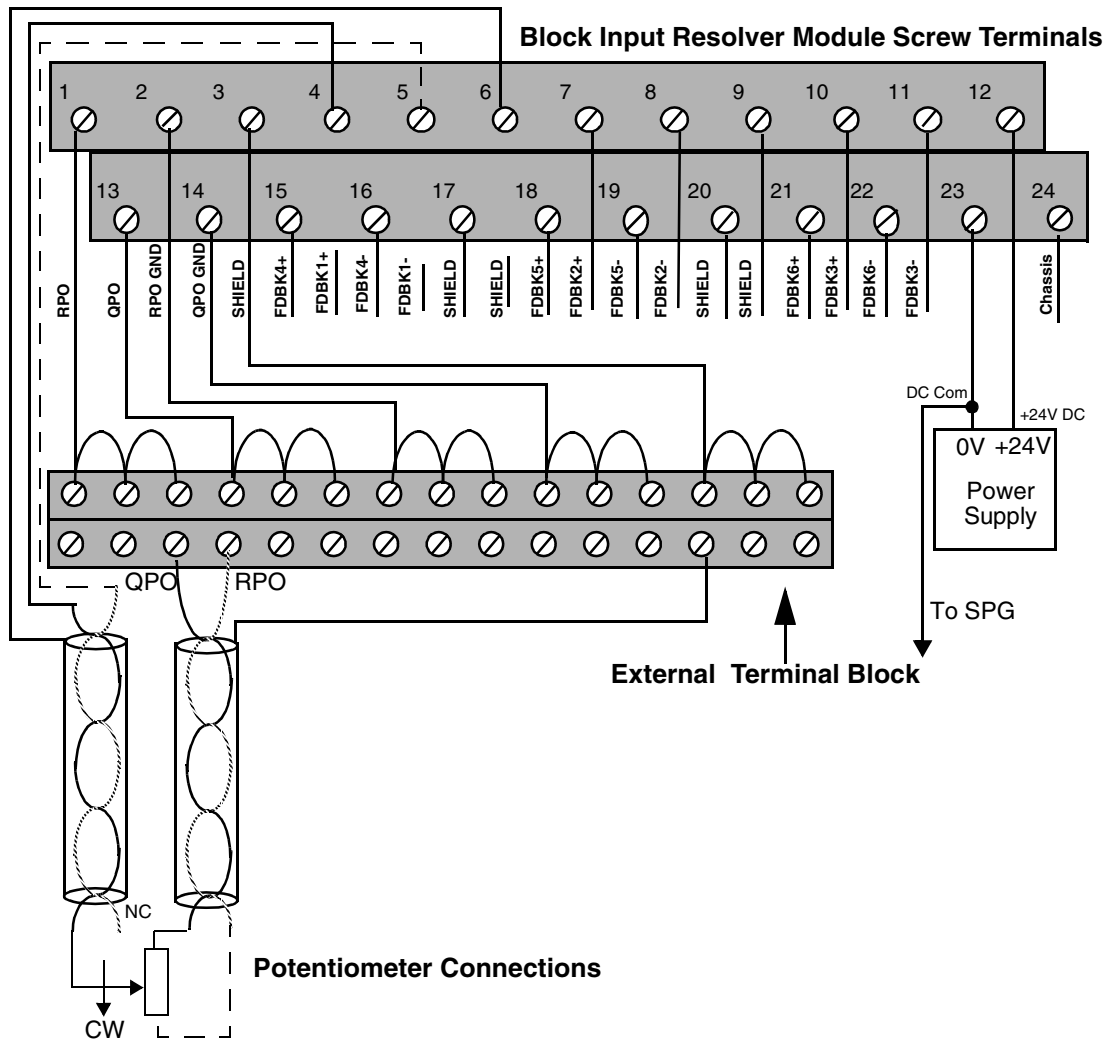

9.2.2 Communications Connections

There are two 5-pin communications connectors and four logic LEDs on the top of the block I/O module as shown in Figure 9-5.

Figure 9-5 Pinouts for Communication Connectors

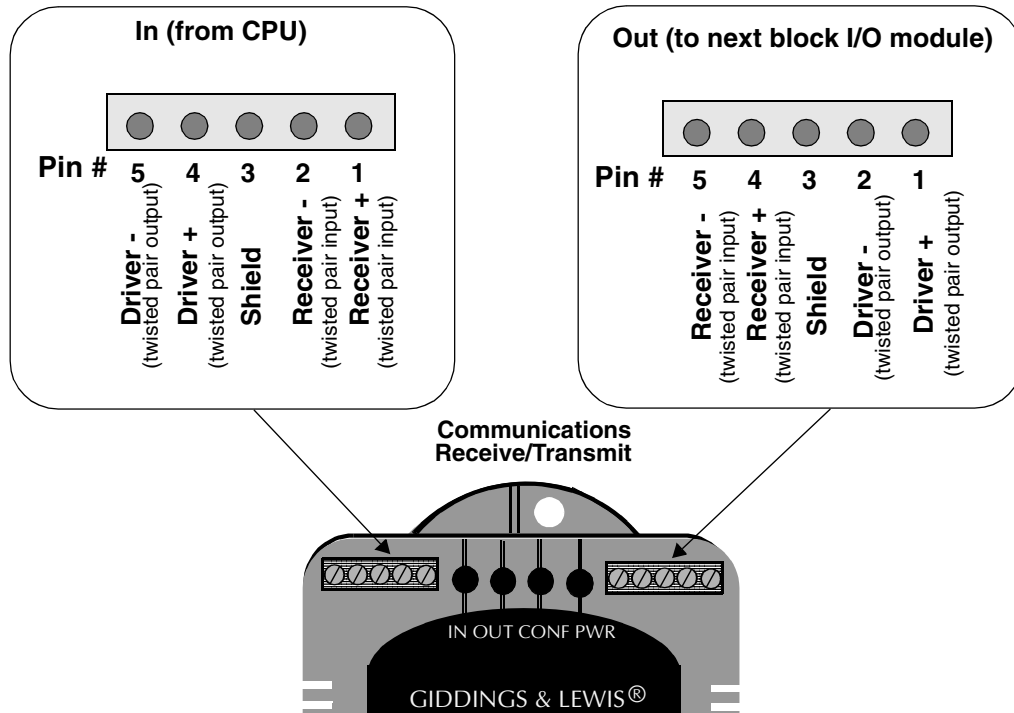

9.2.2.1 LEDs

LED	Color	State	Definition
DATA IN	Yellow	FAINT	Data being passed through the block module
		BRIGHT or OFF	No activity through the block module
DATA OUT	Yellow	FAINT	Data is being passed through the block module
		BRIGHT or OFF	No activity through the block module
CONF	Green	ON	Communication established with this block I/O module
		OFF	Communication not established
PWR	Green	ON	Internal +5V logic power supply OK
		OFF	No external 24V applied or internal 5V logic supply not OK

9.3 Resolvers

A resolver (see Figure 9-6) is a servo feedback device which provides absolute position over one electrical revolution. It receives RPO (reference phase output) and QPO (quadrature phase output) signals from the interface module. RPO and QPO signals are sine waves 90° out of phase with each other. They energize two stator coils positioned at 90° to each other. The stator coils induce a sine wave signal called FDBK (feedback) in the rotor coil. The phase of this signal, with respect to RPO, depends on the rotor coil's position.

Figure 9-6 Diagram of a Resolver

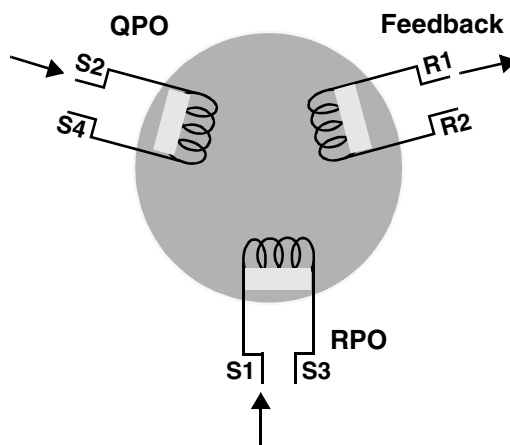

The recommended resolver has a part number in the specification sheet at the end of this section. Other resolvers may be used if they conform to the interface module specifications.

9.4 Theory of Operation

The module sends out two sine wave signals, RPO and QPO. These signals have the same voltage amplitude and frequency but are 90° out of phase. The module then receives a FDBK sine wave signal whose phase is a measure of the angular rotation of the resolver.

A phase shift of 360° corresponds to 4,000 counts of resolution, so one count represents 5.4 arc-minutes of rotation of the resolver.

The value in the on-board memory represents the current position of the resolver. The on-board memory position is updated every 1.5 msec for each of the 6 resolvers. There is a loss of feedback indicator for each resolver.

9.5 Specification Table

Characteristic	Block Input Resolver (6 ch) Module Specifications
Function	Measures the position of a transducer that accepts a 2-phase quadrature excitation, such as a resolver or potentiometer
Part number	M.1017.3138 (old # 503-25986-01)
Field side connector	24 pin card edge connector, screw terminals
Excitation method	2-phase quadrature for control transformer type of resolver
RPO and QPO outputs	
Frequency	4KHz
Output voltage	15 V _{P-P} (5.3V _{RMS})
Current per output channel, max.	100 mA
Resolver transformer ratio	.5 to 1.0
Resolution, resolver	4000 Feedback Units (FUs) per electrical revolution
Resolution, potentiometer	1000 Feedback Units (FUs) per electrical revolution
Accuracy at constant temperature	± 12 arc minutes
Accuracy over temperature range	± 5.4 arc minutes /10°F
Velocity, max.	15000 electrical RPM (1M FU/Sec.)
Cable length, max.	6 ft. from module to terminal block (18 AWG) 100 ft. from terminal block to resolvers (twisted pair)
Stored position value range	0-3999
Logic side LEDs, module status	Data In LED Data Out LED Configured LED Power LED
Module power requirements	200 mA from an external 24V DC supply (20 to 30V DC range) NOTE: 2.5A, 250 microsecond inrush at power on
Recommended resolver	Giddings & Lewis part number 501-98409-00 Harowe 11BRW 300-F-1/10
Other suggested resolvers	Clifton 11BHW-0IE/A004 Kearfott CR410959

CE Marked	<p>Conforms to Directives 73/23/EEC, 89/336/EEC, 92/31/EEC, 93/68/EEC by conforming to the following standards:</p> <p>EN 50081-2:1993 EMC Generic Industrial Emissions EN 50082-2:1995 EMC Generic Industrial Immunity EN 61131-2:1994/A11:1996 Low voltage directive requirements for programmable controllers</p> <p>Operates with emissions below EN55011/ CISPR 11 Class A limits</p> <p>Immune to:</p> <ul style="list-style-type: none"> • Electrostatic discharge (4K V contact mode, 8K V air discharge) per EN61000-4-2 • RF electromagnetic fields per EN61000-4-3, ENV 50141, and ENV50204 • Electrical fast transients per EN61000-4-4 • Magnetic fields per EN61000-4-8 <p>Refer to the EMC Guidelines for more information.</p>
UL and C/UL Listed	File No. E126417 NRAQ Programmable Controllers
Operating temperature range	7° C to 55° C (45° F to 131° F)
Storage temperature range	-40° C to 85° C (-40° F to 185° F)
Humidity	5 to 95%, non-condensing
Physical size	4.05" wide x 4.825" high x 3" deep 102.9 mm x 122.6 mm x 76.2 mm
Vibration (per IEC 68-2-6)	10-57 Hz (constant amplitude .15 mm) 57 - 2000 Hz (acceleration 2 g)
Shock (per IEC 68-2-27)	Four shocks per axis (15g/11 msec)

NOTES

10 Block Output Stepper/Input Encoder/ Input 24V DC Module (2/2/2 Channel)

10.1 Introduction

This block I/O module provides the following:

- Two output stepper channels
- Two input encoder channels
- Two 24V DC inputs

Figure 10-1 Block Output Stepper/Input Encoder/Input 24V DC Module (2/2/2 Ch)

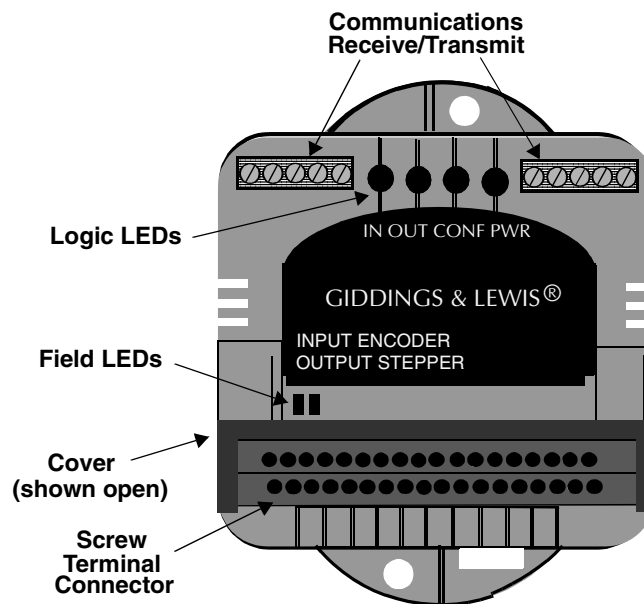

10.1.1 Output Stepper

Each stepper channel can control one stepper drive. The maximum step rate is one million steps per second.

An external power supply (4.5 VDC to 20 VDC) or the internal +5V DC can be used to power each stepper output. Commands and control data are sent to the module, and status and position information are received from the module, via software.

10.1.2 Input Encoder

Each encoder channel can interface to one independent quadrature incremental encoder or equivalent device. Information from each encoder is used to update a separate position counter and latch within the module.

For each channel, a 24-bit counter is incremented or decremented based on signals it receives from the A, \overline{A} , B, and \overline{B} outputs of a quadrature encoder. The counter value can be latched (stored) if the module receives an I or \overline{I} output signal from the encoder.

10.1.3 Input 24V DC

The 24V DC inputs convert DC signals from devices into logic levels that the CPU can use. Each signal is converted into a corresponding logic 1 or 0 which is transmitted through the communication interface to the CPU module. An "on" signal is nominally 24V DC, but can be any level between 15V and 30V. An "off" signal is any level below 5V. The wiring configurations may be sink or source. Two field side LEDs indicate the state of the inputs.

10.2 Connections

A screw terminal connector is provided for each connection as shown in Figure 10-2. Use up to 14 AWG for field side wiring.

Figure 10-2 Screw Terminal Connector Assignments

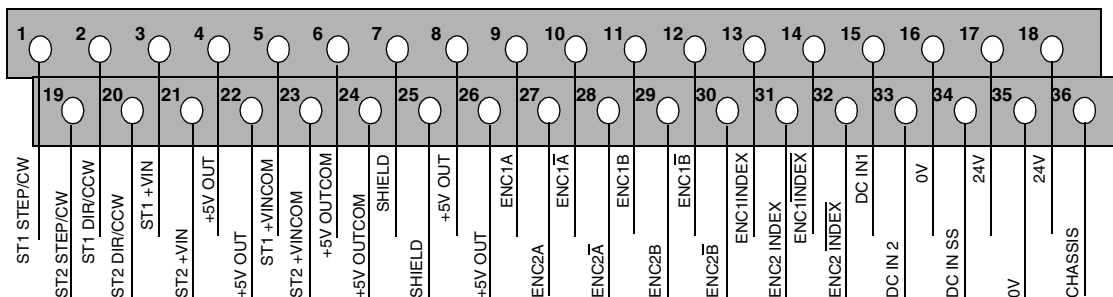

10.2.1 Stepper Connections

For the stepper outputs, the DC power supply can be provided by any combination of the following:

- The stepper drive
- An external DC supply daisy-chained to both outputs
- Separate external DC supplies for each output
- The +5V supply available on the block module

An external DC supply that powers the output signals should have a wire connected from its 0V (COMMON) terminal directly to the controller's single point ground. The power disconnect switch should be the same one used for the system. The following connections for one output are illustrated in Figure 10-3.

ST1+VIN	to the +V terminal of the external power supply or the +5V OUT terminal of the internal power supply
ST1 STEP/CW	to the step or clockwise input of the drive
ST1 DIR/CCW	to direction or counterclockwise input of the drive
ST1 +VINCOM	to the 0V terminal of the external power supply NOTE: When the drive inputs are optically isolated, tie the 0V of the external power supply to SPG or to pin 35.
SHIELD	All shield pins on the module are connected to each other internally and to the chassis screw terminal and the metal strip on the base of the module.

Figure 10-3 Connections for One Stepper Output

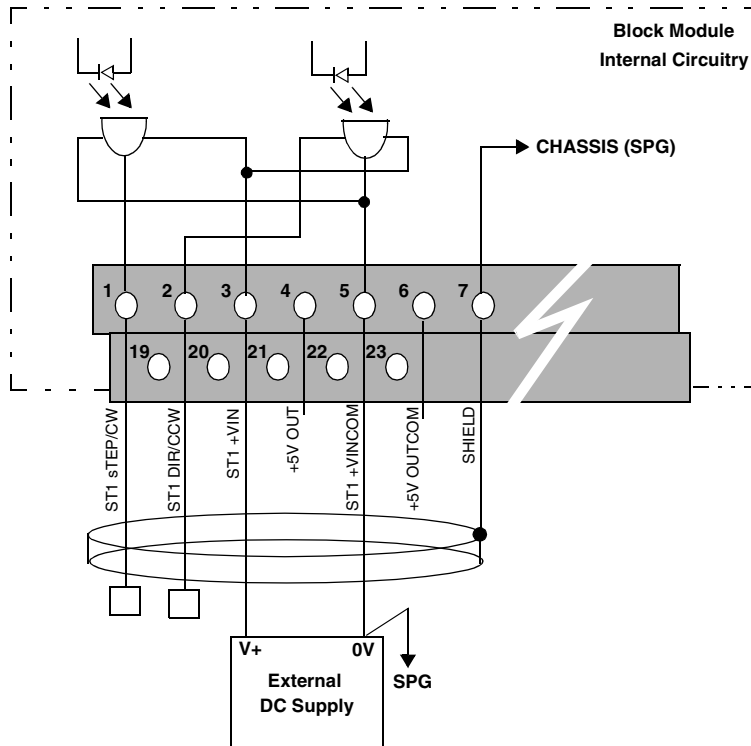

NOTE: As an alternative to an external DC power supply, you can use the +5V available on the block module. See insert for wiring.

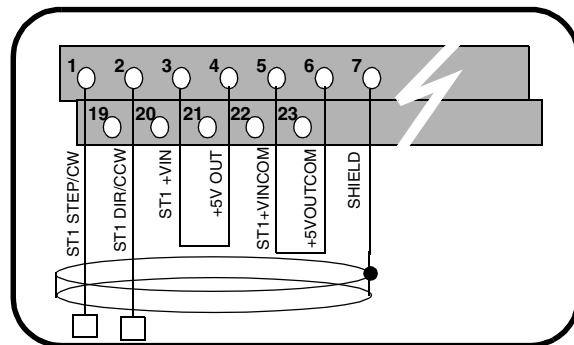

WARNING

The +5V OUT internal power supply available at the terminal screws is also used by the module's logic circuitry. If problems are encountered, use an external power supply instead.

10.2.2 Connecting the Block Module to Stepper Drives

Consult your drive manual regarding the proper connection of an indexer. Four types of drive inputs and the proper connection techniques are shown in Figure 10-4, Figure 10-5, Figure 10-6 and Figure 10-7.

When working with opto-coupler drive inputs, be sure the input diode is protected by a current-limiting resistor as stated in the following important note.

IMPORTANT

There is a limit to the amount of current the input diode of the drive opto-coupler can withstand. If this current is exceeded, the device will be destroyed.

The block module is capable of sinking considerably more current than the 15 mA specified. Most drives having opto-coupler inputs have a series current-limit resistor sized properly for a +5V external supply.

If the drive being used has an opto-coupler input but does not have a current-limit resistor or if the current-limit resistor is too small, then one will have to be added externally. Consult your drive manual for information regarding this topic.

Following the wiring guidelines listed below will increase the reliability of the block module/drive system.

1. Route the wiring from the block module separately from any high current or electrically noisy wiring.
2. Keep the wires connecting the block module to the drive less than 10 feet in length.
3. Shield the wiring from the block module. Tie shields to the block module shield terminal screw and leave the other end of the shield unconnected.

10.2.2.1 Opto-Coupler Drive Inputs

The inputs for this type of drive will be:

- Step +
- Step -
- Direction +
- Direction -

Make the following connections as shown in Figure 10-4.

Block Module		External Power Supply		Drive
ST1 STEP/CW	to	N/C	to	Step -
ST1 DIR/CCW	to	N/C	to	Direction -
ST1 +VIN	to	+V	to	Step + and Direction +
ST1 +VINCOM	to	0V	to	N/C

Figure 10-4 Block Module (Stepper) Connections to Opto-Coupler Drive Inputs

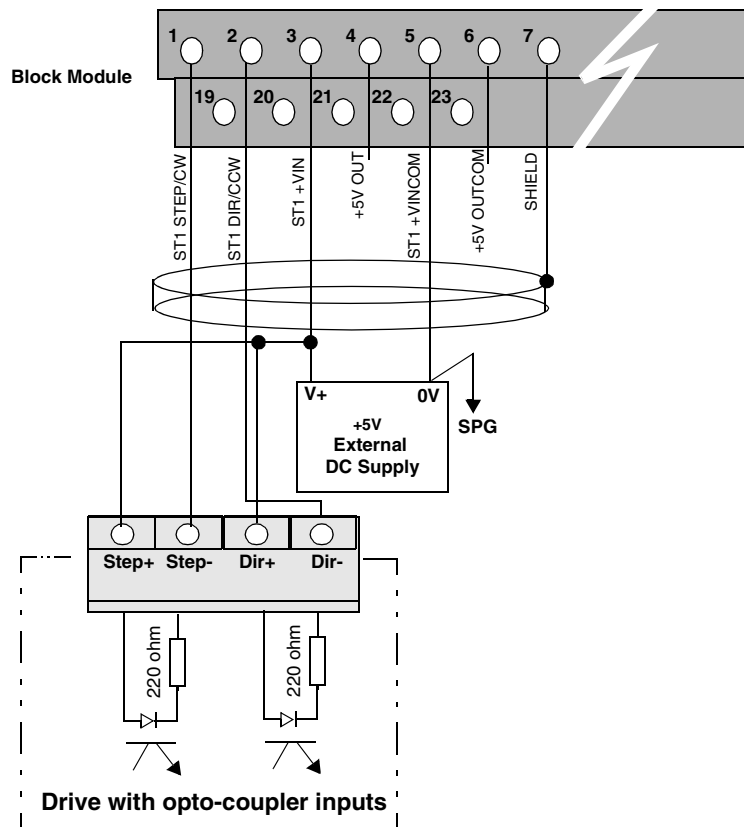

10.2.2.2 Opto-Coupler with Common Source Drive Inputs

The inputs for this type of drive will be:

- Opto power input
- Step
- Direction

Make the following connections as shown in Figure 10-5:

Block Module		External Power Supply		Drive
ST1 STEP/CW	to	N/C	to	Step
ST1 DIR/CCW	to	N/C	to	Direction
ST1 +VIN	to	+V	to	Opto power input
ST1 +VINCOM	to	0V	to	N/C

Figure 10-5 Block Module (Stepper) Connections to Opto-Coupler Drive Inputs

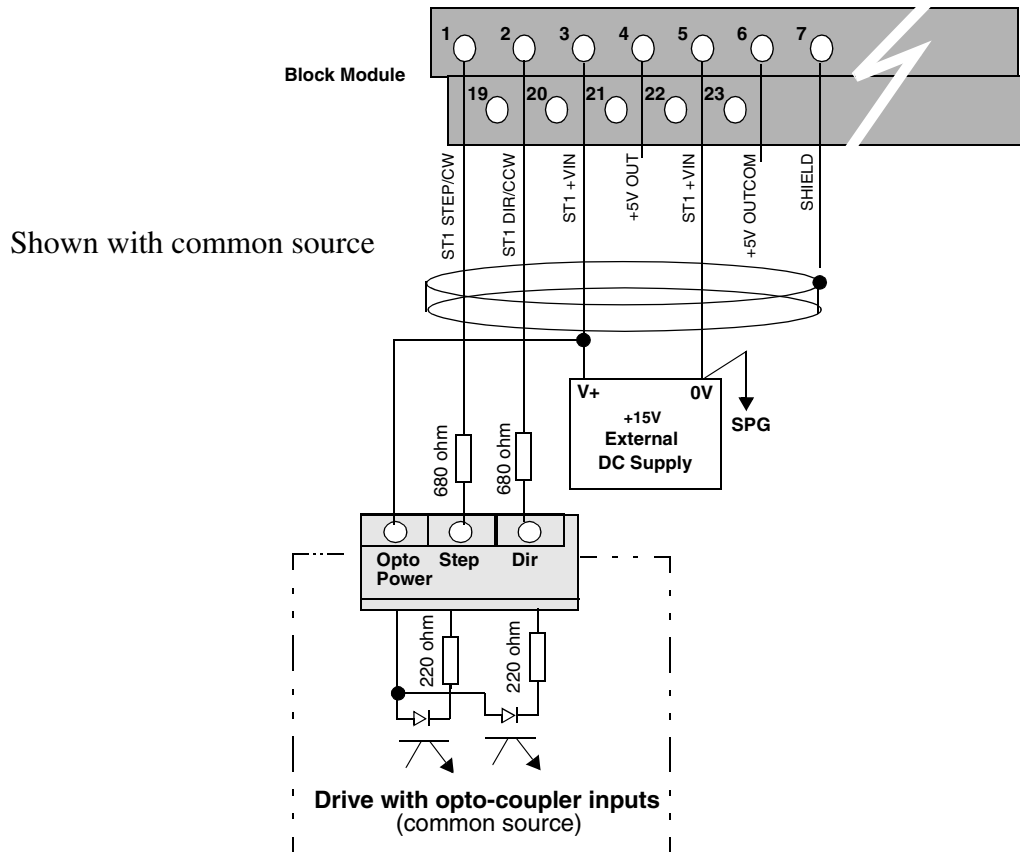

10.2.2.3 Single-Ended Drive Inputs

The inputs for this type of drive will be:

- Step
- Direction
- Signal ground

Make the following connections as shown in Figure 10-6.

Block Module	Power Supply	Drive
ST1 STEP/CW	to N/C	to Step
ST1 STEP/CCW	to N/C	to Direction
ST1 +VIN	to +V	to N/C
ST1 +VINCOM	to 0V	to Signal ground

Figure 10-6 Block Module (Stepper) Connections to Single-Ended
Drive Inputs

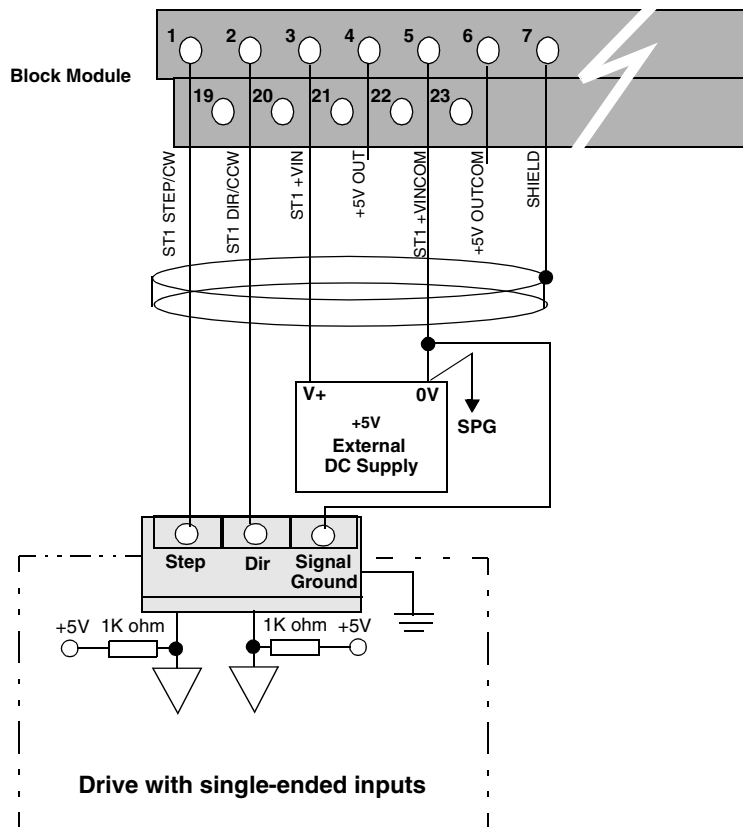

If the pull-up resistors internal to the drive are inadequate, you may need to add external pull-up resistors. Install them as close as possible to the drive.

10.2.2.4 Differential Drive Inputs

The inputs for this type of drive will be:

- Step +
- Step -
- Direction +
- Direction -
- Signal ground

Make the following connections as shown in Figure 10-7.

Block Module		Power Supply		Drive
ST1 STEP/CW	to	N/C	to	Step +
ST1 DIR/CCW	to	N/C	to	Direction +
ST1 +VIN	to	+V	to	N/C
ST1 +VINCOM	to	0V	to	Signal ground

**Figure 10-7 Block Module (Stepper) Connections
to Differential Drive Inputs**

NOTE: If the Step - and Direction - are not biased to one half the external supply by the drive, external voltage dividers will be required. Install the voltage dividers as close to the drive as possible.

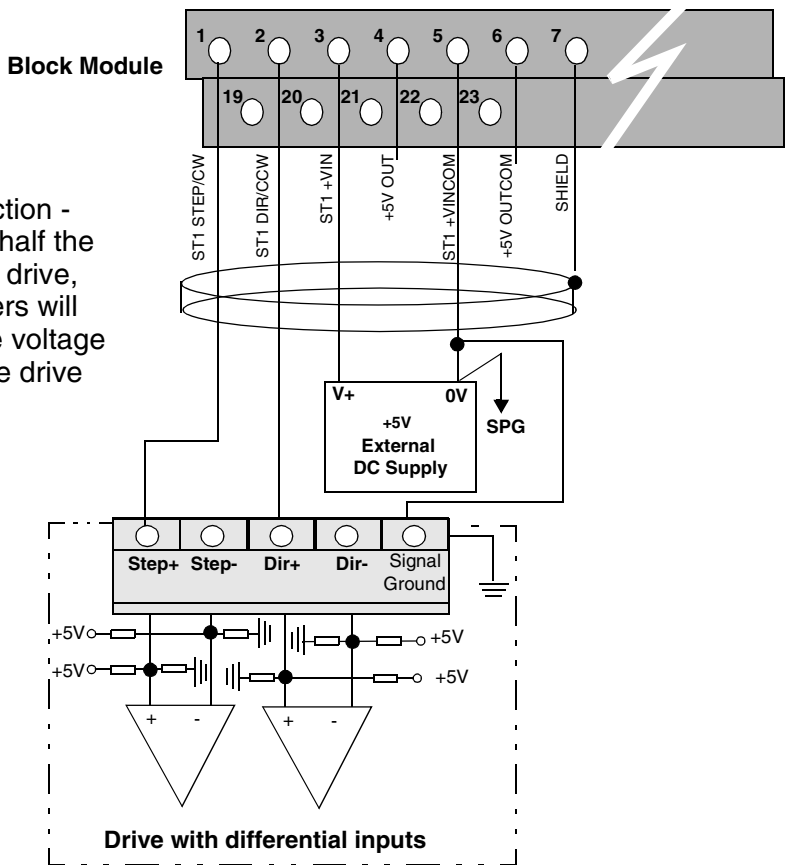

10.2.3 Block Module Encoder Connections

All signals to the encoder inputs of the block module must come to its screw terminal connector through shielded twisted pair wires. These wires must be protected against electrical noise because of the speed and/or voltage levels of the signals transmitted through them. See the discussion on "Preventing electrical noise in data lines" in the Hardware chapter.

Each encoder module channel has three signal pairs, each of which has two screw terminal connections. The signal pairs are:

- encoder input A and \overline{A}
- encoder input B and \overline{B}
- index input and $\overline{\text{index}}$

In addition the module has screw connections for terminating the shields. All shield pins on the module are connected to each other internally and to the chassis screw terminal and the metal strip on the base of the module.

IMPORTANT

The power supply to the encoder (or signal source device) must have its common connected to the SPG.

Figure 10-8 shows the assignments for all the screw terminal connections on the module. To make the diagram more readable, the shielded twisted pair wires are shown with transparent shields.

WARNING

The +5V OUT internal power supply available at the terminal screws is also used by the module's logic circuitry. If problems are encountered, use an external power supply instead.

Figure 10-8 Block Module (Encoder) Connections

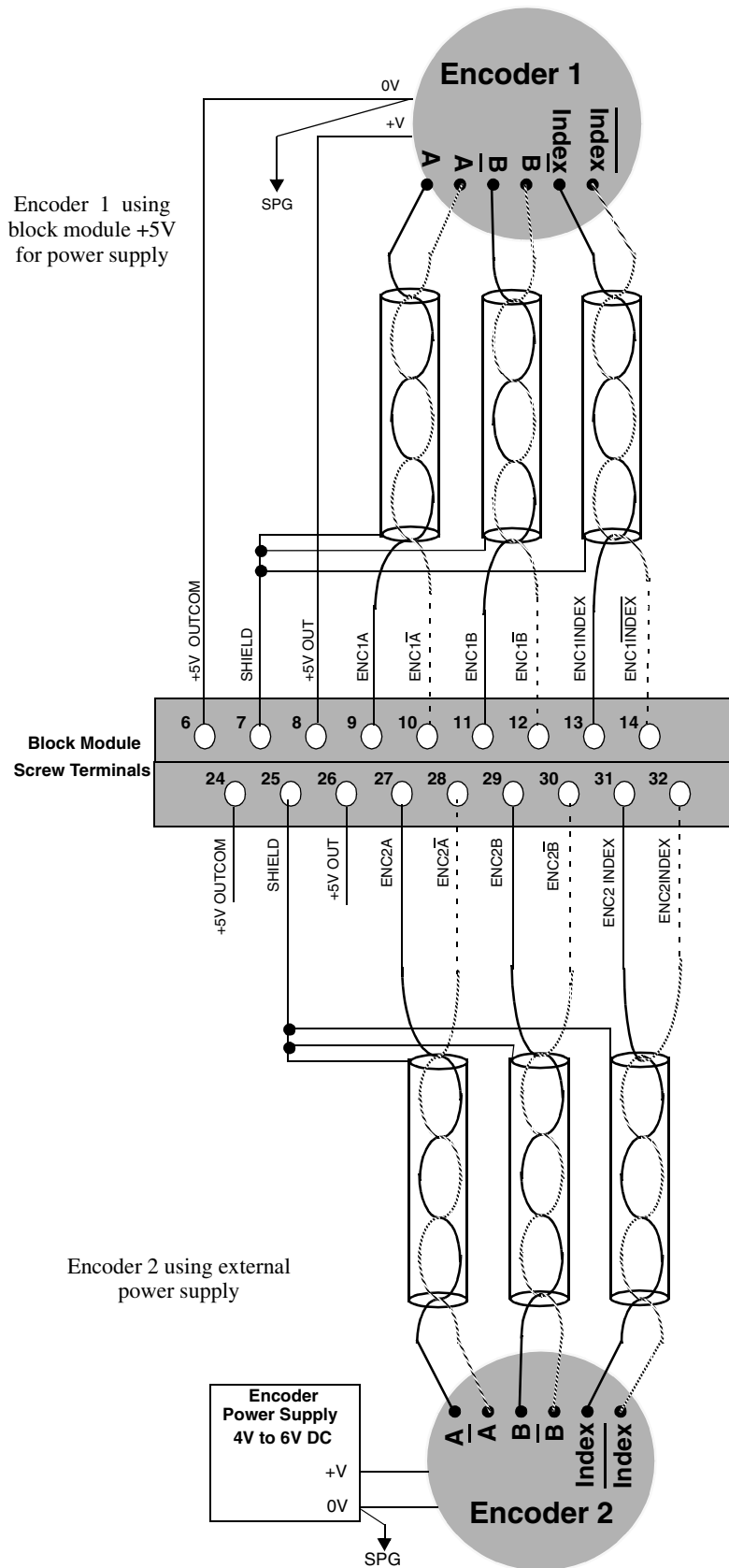

10.2.3.1 Encoder Drivers

Acceptable drivers provided by encoder manufacturers include:

Differential voltage drivers 75183
8830
75114
9614
26LS31

NOTE

Encoders with differential drivers are required. They provide better noise immunity and capability for the module to detect "loss of feedback." See the section in the Hardware chapter on "Preventing electrical noise in data lines" for a comparison between differential and single-ended interfaces.

The three encoder outputs are paired:

- A and \bar{A}
- B and \bar{B}
- index and $\overline{\text{index}}$

10.2.4 Block Module DC Input Connections

The external DC supply used to power the input signals should have a wire connected from its 0V (common) terminal directly to the single-point ground used for the system rack. Its power disconnect switch should be the same one used for the system rack. The DC inputs can be set up as sinking or sourcing.

The drawing on the left side of Figure 10-9 shows devices "sinking" current through the DC inputs. The HOT terminal of the power supply must be connected to the module at DCInSS. The drawing on the right side of Figure 10-9 shows devices "sourcing" current through the DC inputs. The COMMON terminal of the power supply must be connected to the module at DCInSS.

Figure 10-9 Sinking or Sourcing Connections for DC Input

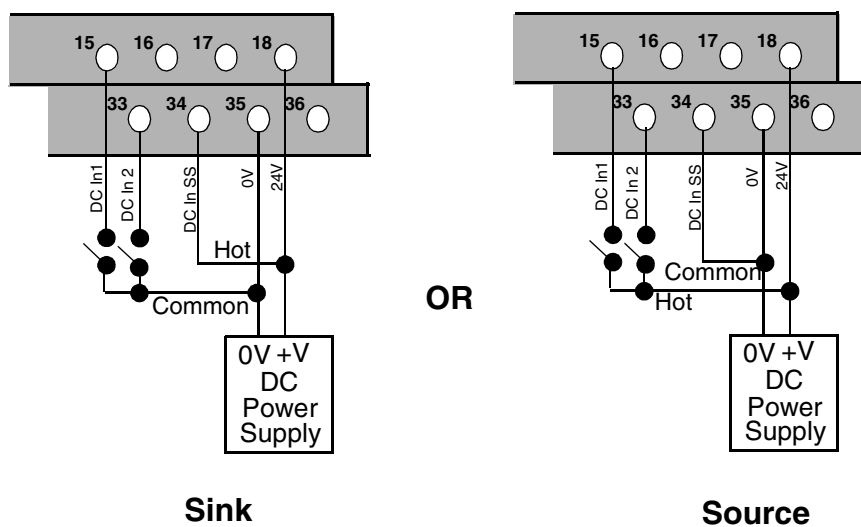

10.2.5 Power Connections

An external 24V DC supply must be connected to pins 18 and 35 as shown in Figure 10-9.

10.2.6 Communications Connections

There are two 5-pin communications connectors and four logic LEDs on the top of the block I/O module as shown in Figure 10-10 below.

Figure 10-10 Pinouts for Communication Connectors

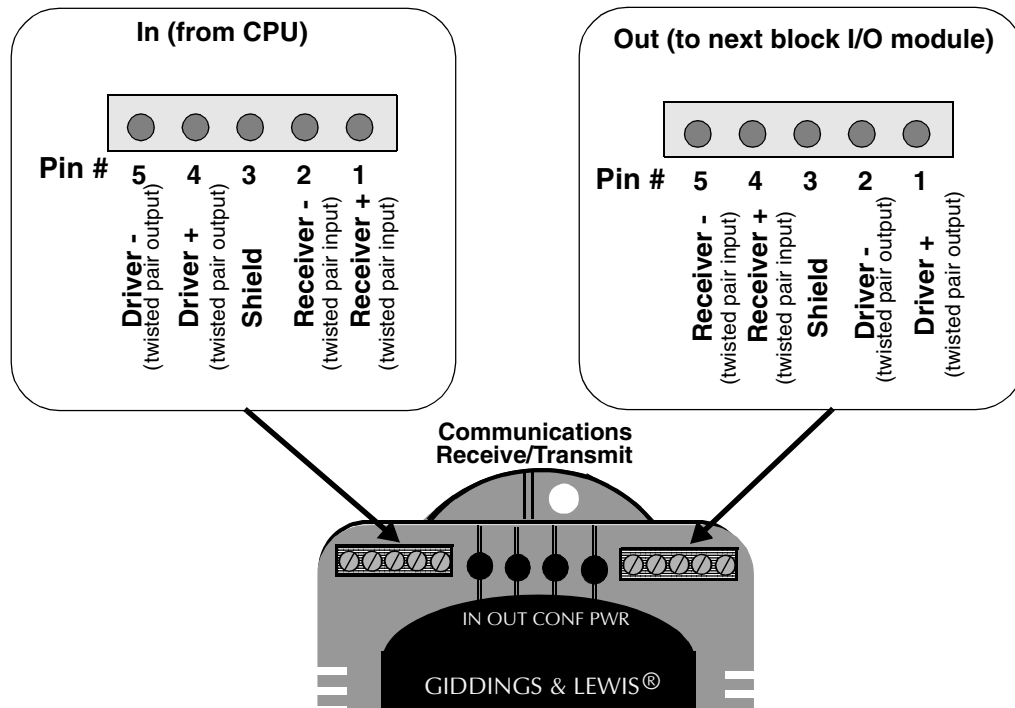

10.2.6.1 LEDs

LED	Color	State	Definition
DATA IN	Yellow	FAINT	Data being passed through the block module
		BRIGHT or OFF	No activity through the block module
DATA OUT	Yellow	FAINT	Data is being passed through the block module
		BRIGHT or OFF	No activity through the block module
CONFIG	Green	ON	Communication established with this block I/O module
		OFF	Communication not established
PWR	Green	ON	Internal +5V logic power supply OK
		OFF	No external 24V applied or internal 5V logic supply not OK

10.3 Theory of Operation

10.3.1 Stepper Theory of Operation

The stepper section of the block module is part of an open loop control system used to position from one to two axes. The diagram in Figure 10-11 illustrates one axis being controlled by the block module. Digital signals from the block module are converted into fixed increments of motion via the stepper drive. This allows the stepper motor to move the load accurately and reliably by following the number of input steps.

Figure 10-11 Open Loop Stepper System

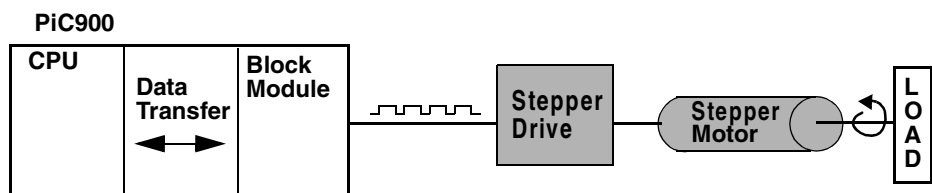

The block module controls the position, velocity, and acceleration of the stepper motor. The number of pulses generated by the block module provides distance information (steps) and the rate of these pulses provides velocity information (steps/sec). The rate of change of the pulse rate provides acceleration/deceleration information (steps/sec/sec).

Commands (acc/dec rates, maximum velocity, reference position, distance, position, and velocity moves) and control data (E-stop, C-stop, start, pause, continue, modes) are sent to the module and status and position information are received from the module via software. Each channel can have up to 500 commands queued up on the module.

The step rate programmed by you for a velocity command (or calculated by the block module during acceleration or deceleration) versus the actual rate output from the block module is defined by the following equation:

$$ActualRate = \frac{10 \times 10^6}{X}$$

where X is the integer quotient of $\frac{10 \times 10^6}{ProgrammedRate}$

Refer to the PiCPro for Windows Software Manual for information on controlling the block module via software.

10.3.2 Block Module Encoder Theory of Operation

The encoder section of the block module uses differential type inputs to interface with up to two independent incremental encoders.

10.3.2.1 Incremental Encoders

An *incremental encoder* is a position transducer. It transmits signals through its "A" and "B" outputs with a frequency proportional to the rotational velocity of its shaft. It transmits a pulse through its index output once per revolution of the device.

There are two types of incremental encoders, quadrature and pulse. Only quadrature encoders can be used with the block module.

A *quadrature encoder* sends square wave type signals. When the shaft rotates at a constant velocity, the A and B outputs are square waves and are at the same frequency. However they are out of phase with each other by 90° . When the encoder shaft rotates in one direction, each A pulse leads the corresponding B pulse by 90° . When it rotates the other direction each A pulse lags its B pulse by 90° .

The signals illustrated in Figure 10-12 indicate that the encoder shaft rotates in one direction at first. Its speed of rotation decreases to 0 and then it starts rotating in the other direction. The signals are shown as differential. \bar{A} is the inverse of the signal A and \bar{B} is the inverse of signal B.

Figure 10-12 Signals Transmitted by a Quadrature Encoder with Differential Outputs

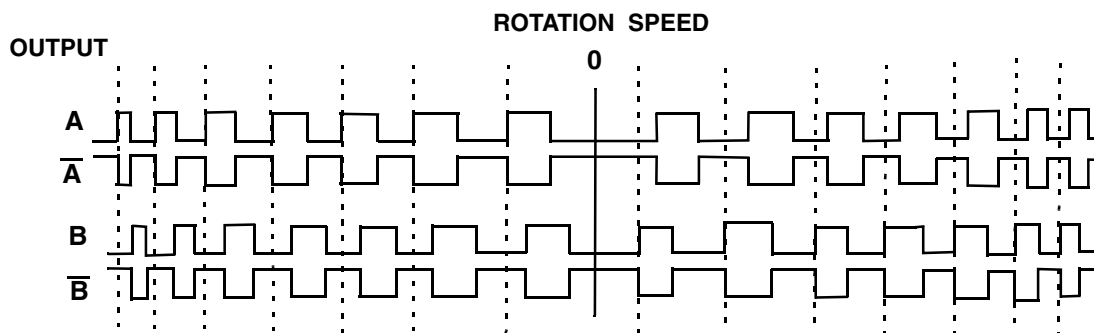

Quadrature Type Encoder

The signal at output A or B from the encoder has a frequency that is the product of the resolution of the encoder in pulses (lines) per revolution and the speed of the encoder in revolutions per second.

Thus an encoder that generates 2,000 pulses (lines) per revolution and rotates at 10 revolutions per second generates 20,000 pulses (lines) per second. In a quadrature type encoder, the interface module would supply 80,000 Feedback Units per second.

The maximum input frequency is 250,000 lines per second, which results in 1,000,000 Feedback Units (FUs) per second in the encoder module.

Figure 10-13 Counting Quadrature Pulses

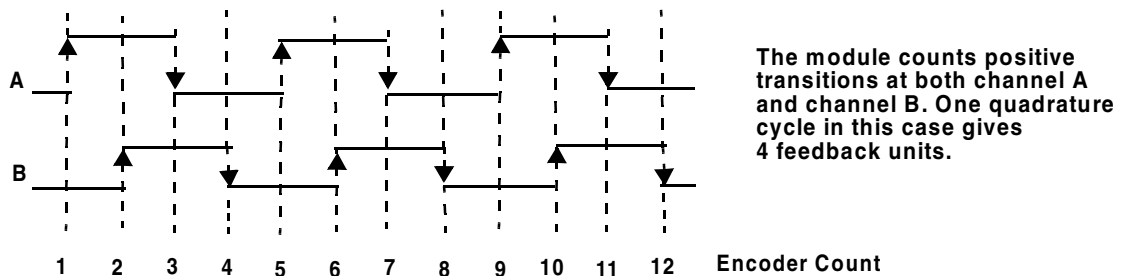

For each encoder channel, there is a 24-bit up/down counter. It is incremented or decremented in accordance with the signals received from the differential quadrature encoder. There is also a 24-bit latch associated with each encoder input channel.

The module can be programmed so that the counter value is "latched" or stored upon receiving an index pulse from the encoder.

10.3.3 DC Input Theory of Operation

Each input is guaranteed "on" at 15 to 30 VDC and guaranteed "off" at 0 to 5 VDC; polarity doesn't matter. Its on/off state is converted to a corresponding logic 1 or 0. This logic state is transmitted through the communication interface to the CPU module, where the processor uses it as data in the ladder program. The logic side of the input is optically isolated from the field side.

The logic state of each input is represented by an LED. If you need to know whether voltage is present at the field side, use a voltmeter on the terminal screws.

The shaded blocks in Figure 10-14 show the limits specified by the IEC. The lines show the maximum and minimum V/I of the inputs in this module. The voltage/current curve in this graph shows that the input module is well within the IEC Type 1 limits.

Figure 10-14 Input Characteristics Compared to IEC Standards

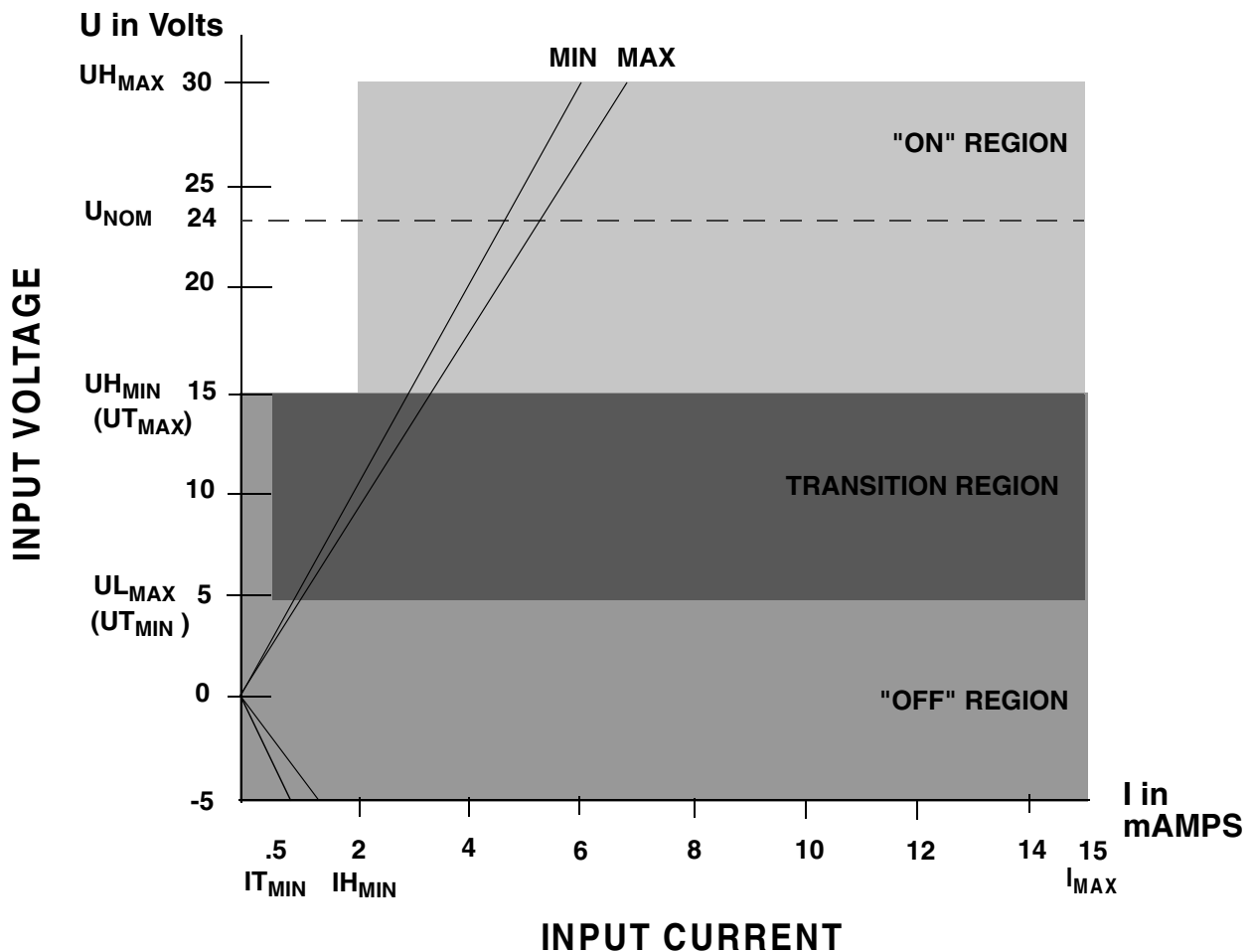

IMPORTANT

Switching devices can sometimes have a leakage current that exceeds the $I_{T_{min}}$ (current allowed when off) of an input module. In order to use such a device, an impedance (typically, a resistor) needs to be used in parallel with the input.

For example, some of the newer proximity switches use two wires instead of three. The third wire was used for a power or ground line. Without the third wire, the switch is easier to install. However, it requires more leakage current in the off state to power its internal circuitry.

As a conservative estimate, use the following formula to calculate an external resistance value. It keeps the input voltage at or below 2.4V when the switching device is in the "off" state.

$$\frac{2.4V}{\text{Switch Leakage} - 0.75mA} \geq R$$

If the switch leakage specification is ≤ 1.7 mA, then:

$$\frac{2.4V}{1.7 - 0.75mA} \geq 2.5K\Omega$$

Use a resistor less than or equal to 2.5 K Ω . Be sure that the wattage is adequate for the resistor when the switching device is in the "on" state remembering that:

$$P = \frac{V_{ON}^2}{R}$$

10.4 Specification Table

Characteristic	Block Output Stepper/Input Encoder/Input 24V DC (2/2/2 ch) specifications
Function	Includes two stepper outputs, two encoder inputs and two DC inputs
Part number	M.1017.3143 (old # 503-25988-01)
Field side connector	Two 18-pin connectors, screw terminals
Logic side LEDs, module status	Data In LED Data Out LED Configured LED Power LED
Module power requirements	300 mA from an external 24 VDC supply (20 to 30 VDC range) NOTE: 1.1 A, 250 microsecond inrush at power on
Current output from +5V Out pins	500 mA total available from the module
Operating temperature range	7° C to 55° C (45° F to 131° F)
Storage temperature range	-40° C to 85° C (-40° F to 185° F)
Humidity	5 to 95%, non-condensing
CE Marked	<p>Conforms to Directives 73/23/EEC, 89/336/EEC, 92/31/EEC, 93/68/EEC by conforming to the following standards:</p> <p>EN 50081-2:1993 EMC Generic Industrial Emissions EN 50082-2:1995 EMC Generic Industrial Immunity EN 61131-2:1994/A11:1996 Low voltage directive requirements for programmable controllers</p> <p>Operates with emissions below EN55011/ CISPR 11 Class A limits</p> <p>Immune to:</p> <ul style="list-style-type: none"> • Electrostatic discharge (4K V contact mode, 8K V air discharge) per EN61000-4-2 • RF electromagnetic fields per EN61000-4-3, ENV 50141, and ENV50204 • Electrical fast transients per EN61000-4-4 • Magnetic fields per EN61000-4-8 <p>Refer to the EMC Guidelines for more information.</p>
UL and C/UL Listed	File No. E126417 NRAQ Programmable Controllers
Physical size	4.05" wide x 4.825" high x 3" deep 102.9 mm x 122.6 mm x 76.2 mm

*Block Output Stepper/Input Encoder/ Input 24V DC
Module (2/2/2 Channel)*

Stepper Section	
+V input (from external supply)	4.5 VDC to 20 VDC, 45 mA per connected channel
Step/CW output rating Direction/CCW output rating	Totem pole, 15 mA sink, 5 mA source
Protection of logic circuits	Optical isolation between the logic and field side
Position range	±2,147,352,575 steps
Step rate	0 to 1,000,000 steps/sec
Step rate accuracy	$ActualRate = \frac{10 \times 10^6}{X}$ where X is the integer quotient of $\frac{10 \times 10^6}{ProgrammedRate}$
Acceleration/deceleration rate	1 to 16,777,215 steps/sec/sec
Reference range	±2,147,352,575 steps
Response to scan loss	Pulse output halted
Encoder Section	
Encoder (A, B, and index)	2231 Differential Receiver
Guaranteed on, min.	2.5 VDC @ 2.5 mA
Input voltage, max.	7 VDC
Input current, max.	22 mA @ 7 VDC
Signal pulse width, min.	.6 μs(600 ns)
Quad signal freq, max.	250 KHz for A or B input (1 M FU count rate)
Encoder device	Quadrature type incremental encoder
Position range	24-bit up/down counter
Cable length, max.	200 ft. @ 250 KHz and 45° quad error

DC Input Section	
Input signals (meet IEC standards)	Nominal 24 VDC on, 0 VDC off
UH Max (max. allowed voltage)	30 VDC
IH Max (max. current @ 30 VDC)	7.5 mA
UL Min	Polarity independent
Guaranteed on	15 VDC
IH Min (min. current @ UH Min)	2.8 mA
Guaranteed off	5 VDC
IT Min (current allowed when off)	.75 mA
Time delay on	1 ms max.
Time delay off	1 ms max.
Protection of logic circuits	Optical isolation between the logic and field sides, transient suppression on the 24V external supply
DC inputs	IEC Type 1 inputs per IEC 1131-2. UL 508 spacing
Logic side LEDs, input circuits	A yellow LED for each input
Vibration (per IEC 68-2-6)	10-57 Hz (constant amplitude .15 mm) 57 - 2000 Hz (acceleration 2 g)
Shock (per IEC 68-2-27)	Four shocks per axis (15g/11 msec)

11 Block Input Analog Module (4 Channel)

11.1 Introduction

The block analog input module is designed to interface the PiC with voltage or current output devices to monitor such things as pressure, flow, speed, position, or temperature.

The module has four independent analog conversion channels. Each channel converts a unipolar or bipolar analog input voltage or current into a 14-bit digital value. This data is transmitted to the PiC's CPU for processing.

There is an internal current sense resistor for each channel for use with 0 to 20 mA or 4 to 20 mA devices. This module contains no user adjustable potentiometers or hardware switches. All necessary gain adjustments are done in software.

Figure 11-1 Block Input Analog Module (4 Channel)

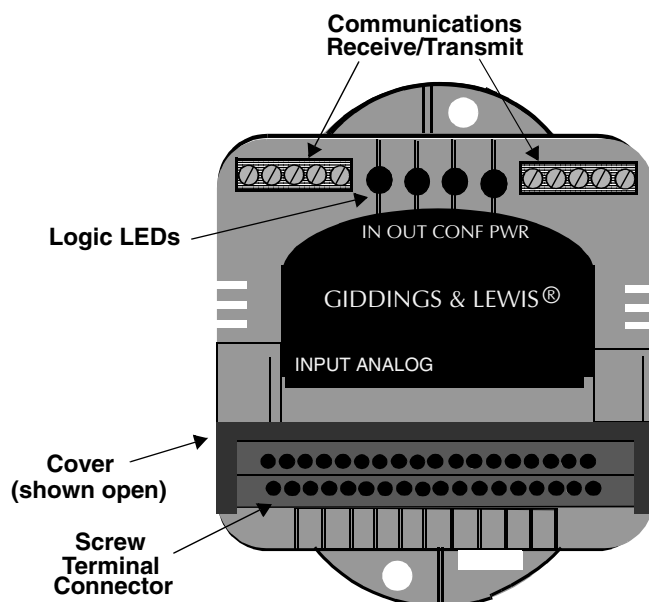

11.2 Connections

All signals to the block input module must come to the screw terminal connectors through shielded twisted pair wires. See the discussion in the Hardware chapter on "Preventing electrical noise in data lines".

Each input channel has three connection pins as shown in Figure 11-2. The signals are:

- +voltage input
- -voltage input
- 250 ohm current sense resistor for 0/20 mA and 4/20 mA applications

The block module has four screw connections for terminating the shields. All four are interconnected within the module so they are the same point electrically. These pins are internally connected to SPG. The shield at the device end of the cable is not connected.

Figure Figure 11-2 shows the assignments for all the screw terminal connections on the module.

Figure 11-2 Connections for the Input Terminals

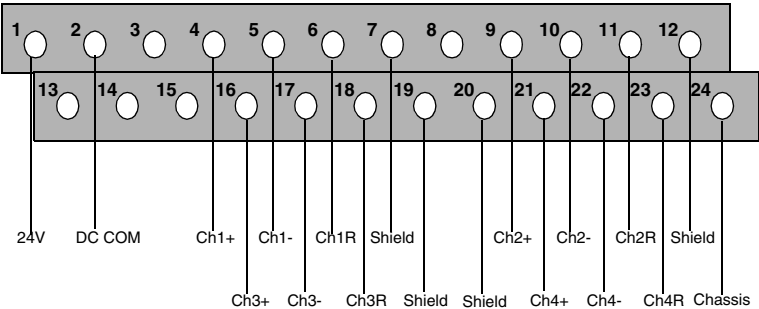

When connecting an analog voltage output device to the module, the positive wire of the twisted pair goes to the + screw terminal and the negative wire goes to the - screw terminal. Figure 11-3 illustrates these connections for channel one.

Notice that no connection is made to the screw terminal with the internal 250Ω resistor when connecting a voltage source device.

Figure 11-3 Voltage Input Connections

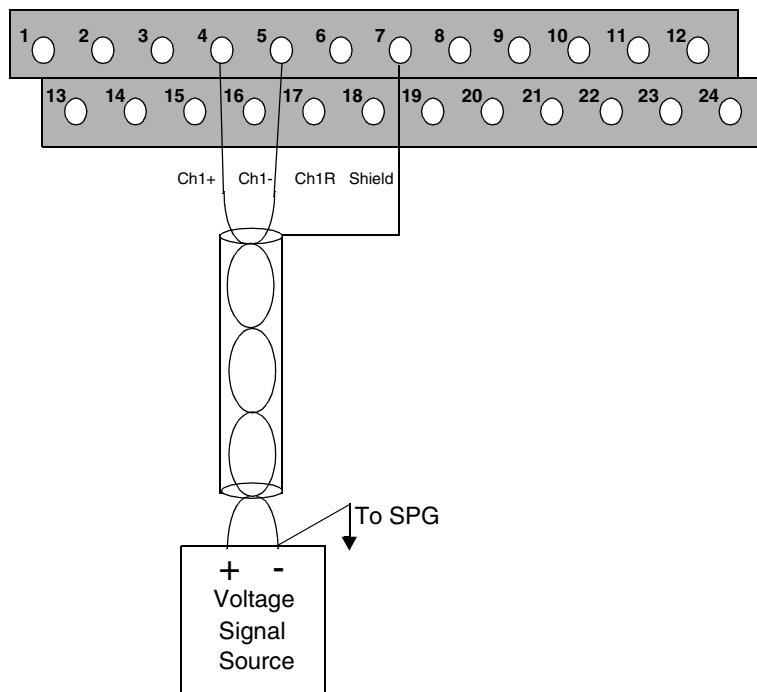

When using a 0 to 20 mA or 4 to 20 mA current output device, the positive wire of the twisted pair is connected to the + input and the negative wire is connected to the 250Ω resistor input.

A jumper is placed between the - input and the 250Ω resistor input as shown in Figure 11-4 (from pin 5 to pin 6 for channel 1). This connects a 250Ω internal resistor across the input.

Figure 11-4 Current Input Connections (0 to 20 or 4 to 20 mA)

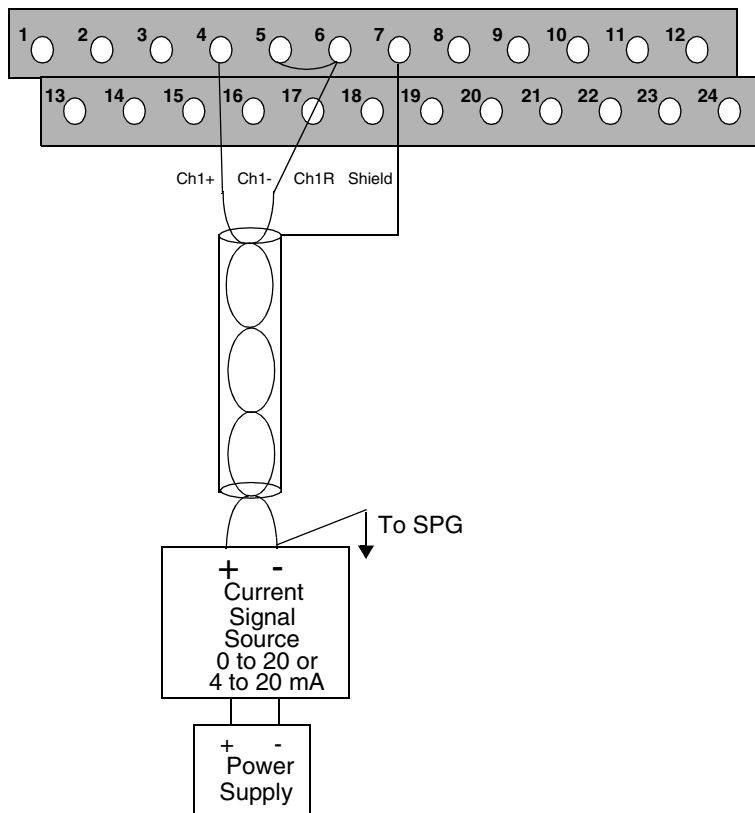

An alternative method of connecting a two wire 4 to 20 mA current device is shown in Figure 11-5. Place a jumper between the - input and the 250Ω resistor input.

Figure 11-5 Current Input Connections (4 to 20 mA)

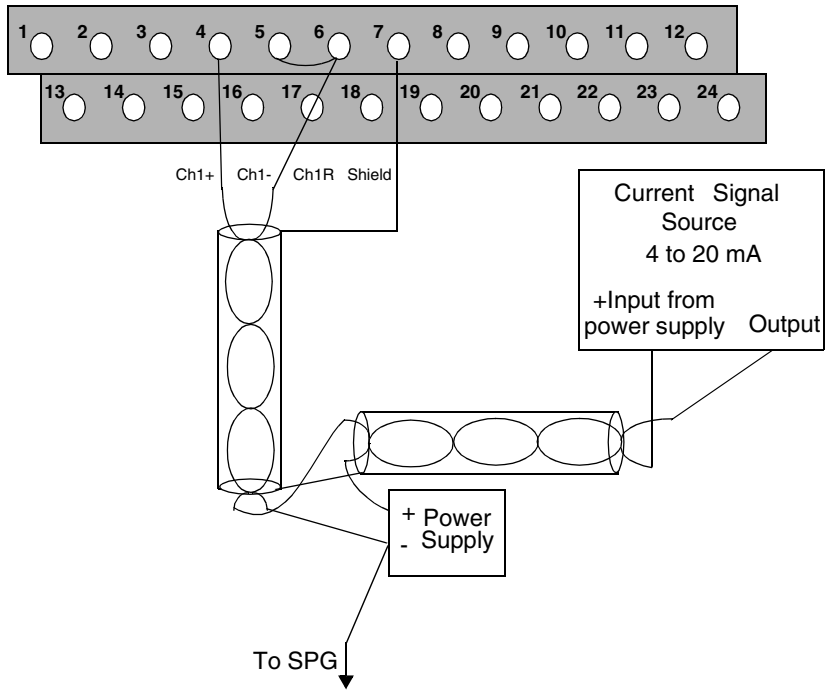
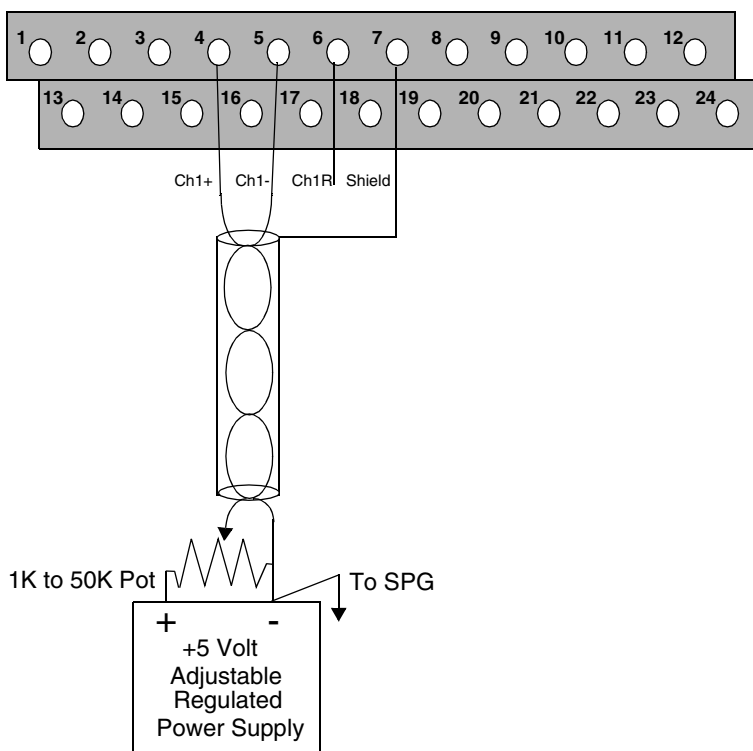

Figure 11-6 illustrates an example of wiring an external potentiometer to the module using twisted pair wire.

For this example, set up the channel initialization function (A_INCHIT) in software for 5 V unipolar.

The 5 V power supply output voltage adjustment can be set for the maximum potentiometer output value. For example, the supply could be adjusted until the VALU output of the analog input channel read function (A_INCHRD) reads 16383 with the pot at its maximum position.

Figure 11-6 Adding an External Potentiometer



11.2.1 Communications Connections

There are two 5-pin communications connectors and four logic LEDs on the top of the block I/O module as shown in Figure 11-7.

Figure 11-7 Pinouts for Communication Connectors

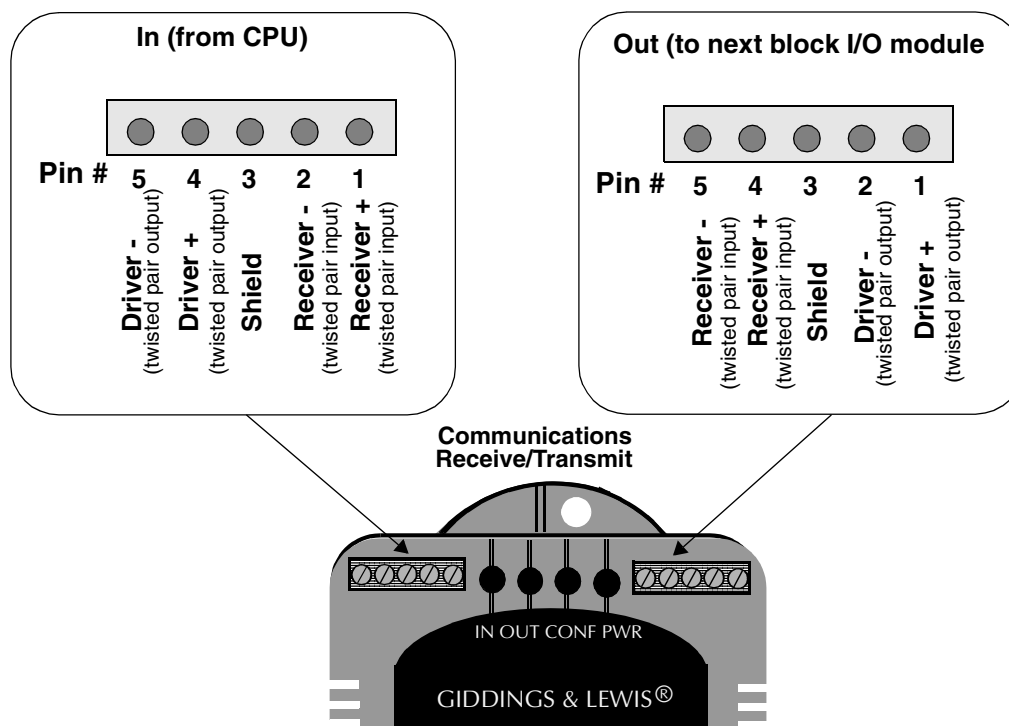

11.2.1.1 LEDs

LED	Color	State	Definition
DATA IN	Yellow	FAINT	Data being passed through the block module
		BRIGHT or OFF	No activity through the block module
DATA OUT	Yellow	FAINT	Data is being passed through the block module
		BRIGHT or OFF	No activity through the block module
CONFIG	Green	ON	Communication established with this block I/O module
		OFF	Communication not established
PWR	Green	ON	Internal +5V logic power supply OK
		OFF	No external 24V applied or internal 5V logic supply not OK

11.3 Theory of Operation

A 14-bit A/D converter samples each channel in sequence at the input scan rate. These values are stored in memory on the module so that any channel value can be read while the A/D converter is processing another channel sample.

Each channel can be set up for a maximum input sensitivity of 5 V or 10 V, bipolar or unipolar, or for 4 to 20 mA or 0 to 20 mA current input. The internal 250 Ω resistor must be connected as shown in Figure 11-4 or Figure 11-5 to sense the current.

All inputs are differential and filtered noise filter time constant of 1 ms.

11.4 Specification Table

Characteristic	Block Input Analog (4 ch) module specification									
Function	Converts an analog input signal into a 14-bit digital word for each of four channels.									
Part number	M.1017.3098 (old # 503-25909-01)									
Field side connector	24-pin card edge connector, screw terminals									
Input channels	4									
Resolution	14 bits, or 16384 steps over the full input range									
Input sensitivity (software selectable)										
Voltage ranges	<table border="0"> <tr> <td></td> <td>Unipolar</td> <td>Bipolar</td> </tr> <tr> <td></td> <td>0 to 10 V</td> <td>±10 V</td> </tr> <tr> <td></td> <td>0 to 5 V</td> <td>±5 V</td> </tr> </table>		Unipolar	Bipolar		0 to 10 V	±10 V		0 to 5 V	±5 V
	Unipolar	Bipolar								
	0 to 10 V	±10 V								
	0 to 5 V	±5 V								
Current range	0 to 20 mA, 4 to 20 mA									
Common mode maximum voltage (The maximum voltage that can safely be applied between either input terminal and circuit common.)	±35V with power on ±20V with power off									
Internal current sense resistor	250 ohms									
Maximum current sense resistor power	.12 W									
Differential input resistance (each input to ground)	1 M Ohms									
Filter time constant	1 ms									
Accuracy of 4-20 mA range	14-bit - .15% of FSR at 25°C ± 100 PPM /°C									
Accuracy of all other ranges	14-bit - .2% of FSR at 25°C ± 100 PPM /°C									
0 Offset	±5 counts @ 10V									
Logic side LEDs, module status	Data In LED Data Out LED Configured LED Power LED									
Module power requirements	160 mA from an external 24V DC supply (20 to 30V DC range) NOTE: 2.5A, 250 microsecond inrush at power on									

CE Marked	<p>Conforms to Directives 73/23/EEC, 89/336/EEC, 92/31/EEC, 93/68/EEC by conforming to the following standards:</p> <p>EN 50081-2:1993 EMC Generic Industrial Emissions EN 50082-2:1995 EMC Generic Industrial Immunity EN 61131-2:1994/A11:1996 Low voltage directive requirements for programmable controllers</p> <p>Operates with emissions below EN55011/ CISPR 11 Class A limits</p> <p>Immune to:</p> <ul style="list-style-type: none"> • Electrostatic discharge (4K V contact mode, 8K V air discharge) per EN61000-4-2 • RF electromagnetic fields per EN61000-4-3, ENV 50141, and ENV50204 • Electrical fast transients per EN61000-4-4 • Magnetic fields per EN61000-4-8 <p>Refer to the EMC Guidelines for more information.</p>
UL and C/UL Listed	File No. E126417 NRAQ Programmable Controllers
Operating temperature range	7° C to 55° C (45° F to 131° F)
Storage temperature range	-40° C to 85° C (-40° F to 185° F)
Humidity	5 to 95%, non-condensing
Physical size	4.05" wide x 4.825" high x 3" deep 102.9 mm x 122.6 mm x 76.2 mm
Vibration (per IEC 68-2-6)	10-57 Hz (constant amplitude .15 mm) 57 - 2000 Hz (acceleration 2 g)
Shock (per IEC 68-2-27)	Four shocks per axis (15g/11 msec)

12 Block Output 4-20mA Module (4 Channel)

12.1 Introduction

The block 4-20mA output module has four independent 4-20mA conversion channels. Each channel converts a 15-bit digital value into a single ended type 4-20mA analog current output signal. The full range of the output signal is 4mA to 20mA, with a 15-bit resolution of one part in 32,768.

A typical use for this module is to supply a control signal to valves. This module contains no user adjusted potentiometers or hardware switches. All necessary adjustments are done in software.

Figure 12-1 Block Output 4-20mA Module (4 Channel)

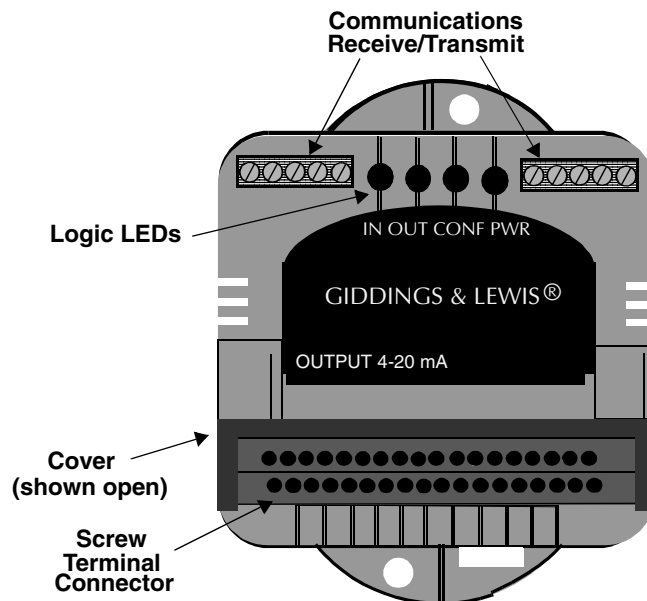

12.2 Connections

Two screw terminal connections are assigned to each channel to carry the signals (see Figure 12-2). The negative outputs of each channel are connected internally to the +V Common.

In addition, the module has four screw terminal connections for terminating the shields. All four are connected internally, so they are the same point electrically.

Two connections are used to connect an external power supply.

Figure 12-2 Screw Terminal Connector Assignments

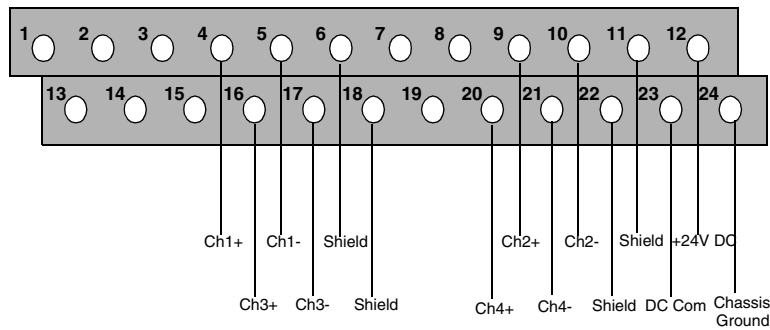

Each 4-20mA output channel is connected to a receiving device with twisted pair wires (see Figure 12-3). For extremely noisy environments, use shielded twisted pair wire.

The shield connections are internally connected to the Single Point Ground (SPG) to which the system rack is connected. No external connection should be made.

Figure 12-3 Receiving Devices and Power Supply Connections

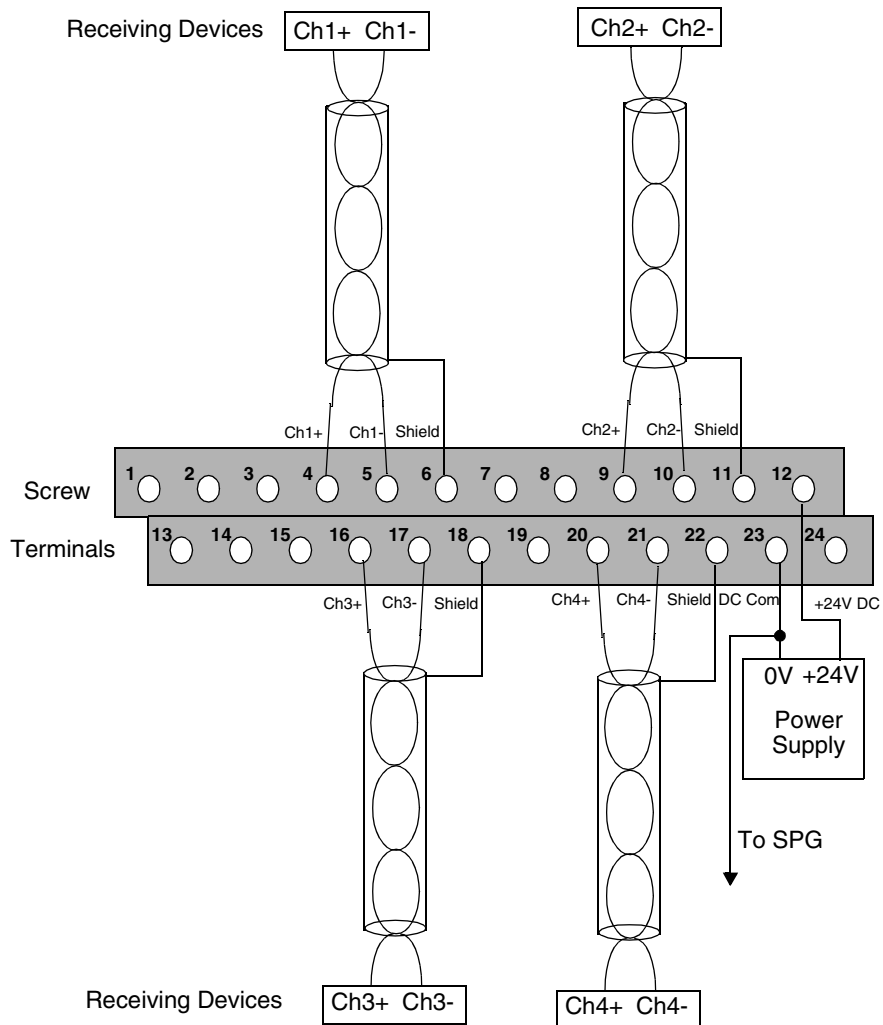

12.2.1 Communications Connections

There are two 5-pin communications connectors and four logic LEDs on the top of the block I/O module as shown in Figure 12-4.

Figure 12-4 Pinouts for Communication Connectors

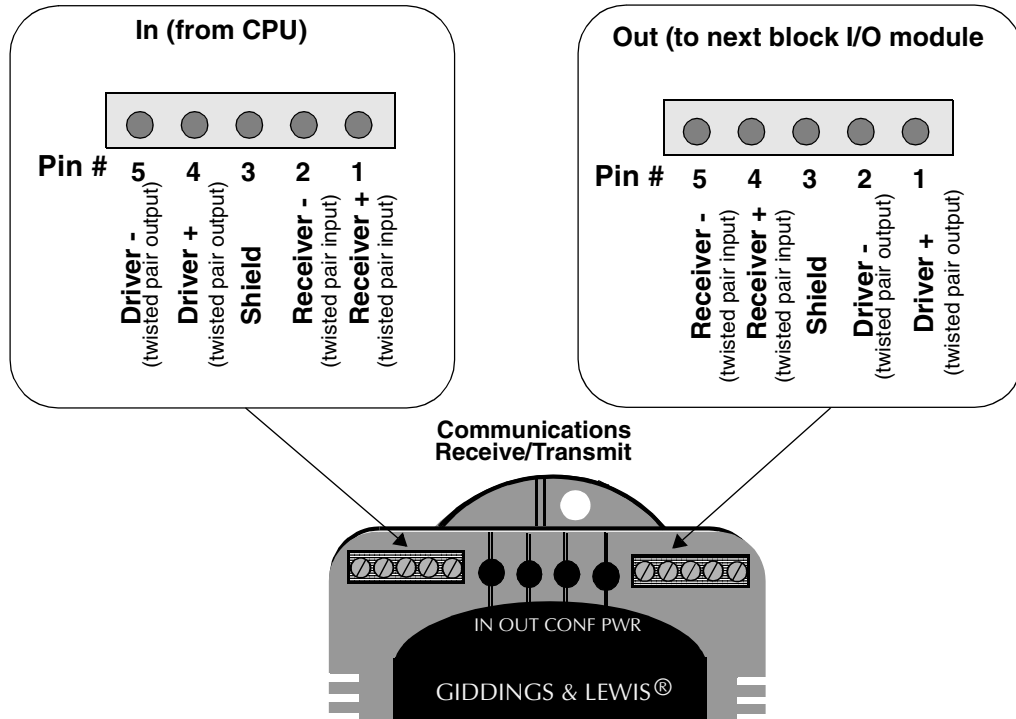

12.2.1.1 LEDs

LED	Color	State	Definition
DATA IN	Yellow	FAINT	Data being passed through the block module
		BRIGHT or OFF	No activity through the block module
DATA OUT	Yellow	FAINT	Data is being passed through the block module
		BRIGHT or OFF	No activity through the block module
CONFIG	Green	ON	Communication established with this block I/O module
		OFF	Communication not established
PWR	Green	ON	Internal +5V logic power supply OK
		OFF	No external 24V applied or internal 5V logic supply not OK

12.3 Theory of Operation

The CPU module sends the output module a 16-bit digital word for each channel used. Each digital word is converted to a corresponding current within the range 4-20mA. The current is brought out to a pair of screw terminal connections as a single-ended type current output.

You can adjust each channel in software for offset adjustments and gain scaling.

For safety reasons, all outputs are automatically reset to 4mA when a scan loss condition occurs.

All outputs have clamping diodes and a capacitor to permit the driving of non-resistive (i.e. inductive) loads.

All outputs can drive loads whose impedance is less than or equal to:

$$\frac{V_{EXT} - 2.5V}{20mA} = R_{LOAD}$$

Example: If $V_{EXT} = 24V$, then the maximum impedance equals:

$$\frac{24V_{EXT} - 2.5V}{20mA} = 1075\Omega$$

The load range in this example is from 0 to 1075 Ω

Anytime the load impedance is exceeded, the OPEN flag is set in software. Normally, it is an open circuit that causes this flag to be set.

12.4 Specification Table

Characteristic	Block Output 4-20mA (4 ch) specification
Function	Converts a 15-bit digital value into a 4-20mA analog current signal for each of four channels
Part number	M.1017.3101 (old # 503-25910-01)
Field side connector	24 pin card edge connector, screw terminals
Output channels	4
Resolution	15 bits, or 32,768 steps over the full output range
Output characteristics @24V DC supply, with temperature = 25° (77°F)	
Accuracy	.25% FSR (Full Scale Range)
Output current, max.	20 mA
Output voltage after power up	$V_{OUT} = 4mA * R_{LOAD}$
Response to "scan loss"	All outputs reset to 4mA
Short circuit protection	Current is limited to: $I_{OUT} = \text{where } I_{OUT} = 4 \text{ to } 20mA$
Logic side LEDs, module status	Data In LED Data Out LED Configured LED Power LED
Module power requirements	200 mA from an external 24V DC supply (20 to 30V DC range) NOTE: 2.5A, 250 microsecond inrush at power on

CE Marked	<p>Conforms to Directives 73/23/EEC, 89/336/EEC, 92/31/EEC, 93/68/EEC by conforming to the following standards:</p> <p>EN 50081-2:1993 EMC Generic Industrial Emissions EN 50082-2:1995 EMC Generic Industrial Immunity EN 61131-2:1994/A11:1996 Low voltage directive requirements for programmable controllers</p> <p>Operates with emissions below EN55011/ CISPR 11 Class A limits</p> <p>Immune to:</p> <ul style="list-style-type: none"> • Electrostatic discharge (4K V contact mode, 8K V air discharge) per EN61000-4-2 • RF electromagnetic fields per EN61000-4-3, ENV 50141, and ENV50204 • Electrical fast transients per EN61000-4-4 • Magnetic fields per EN61000-4-8 <p>Refer to the EMC Guidelines for more information.</p>
UL and C/UL Listed	File No. E126417 NRAQ Programmable Controllers
Operating temperature range	7° C to 55° C (45° F to 131° F)
Storage temperature range	-40° C to 85° C (-40° F to 185° F)
Humidity	5 to 95%, non-condensing
Physical size	4.05" wide x 4.825" high x 3" deep 102.9 mm x 122.6 mm x 76.2 mm
Vibration (per IEC 68-2-6)	10-57 Hz (constant amplitude .15 mm) 57 - 2000 Hz (acceleration 2 g)
Shock (per IEC 68-2-27)	Four shocks per axis (15g/11 msec)

NOTES

13 Block Output $\pm 10V$ DC Module (4 Channel)

13.1 Introduction

The output $\pm 10V$ DC module has four independent D/A conversion channels. Each channel converts a 16-bit digital word into a differential type analog output signal. The full range of the output signal is - 10 V to + 10 V, with a resolution of 1 part in 65,536.

This module contains no potentiometers or hardware switches. All necessary adjustments are done in software.

Figure 13-1 Block Output $\pm 10V$ DC Module (4 Ch)

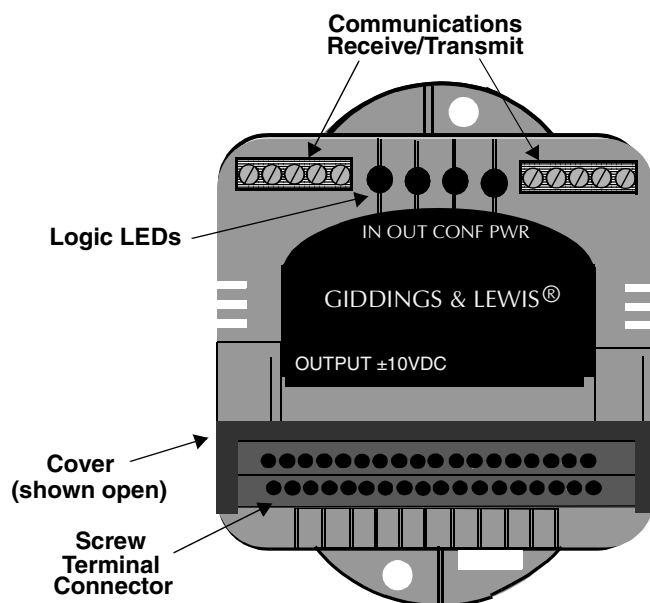

13.2 Connections

Two screw terminal connections are assigned to each channel to carry the signals as shown in Figure 13-2.

In addition, the module has four screw terminal connections for terminating the shields. All four are connected internally, so they are the same point electrically.

Two connections are used to connect an external power supply.

Figure 13-2 Screw Terminal Connector Assignments

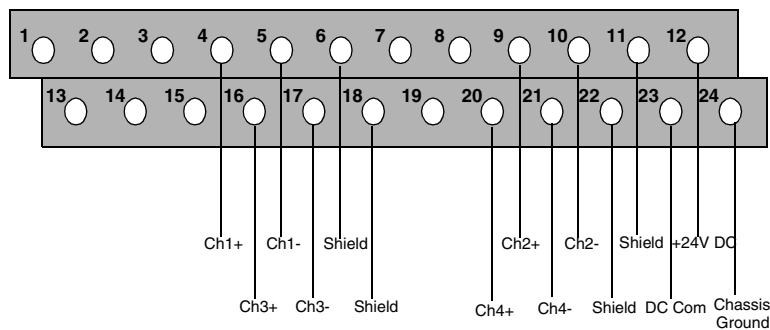

Each output channel is connected to a receiving device with twisted pair wires as shown in Figure 13-3. For extremely noisy environments, use shielded twisted pair wire.

The shield connections are internally connected to the Single Point Ground (SPG) to which the system rack is connected. No external connection should be made.

13.2.1 Communications Connections

There are two 5-pin communications connectors and four logic LEDs on the top of the block I/O module as shown in Figure 13-3.

Figure 13-3 Pinouts for Communication Connectors

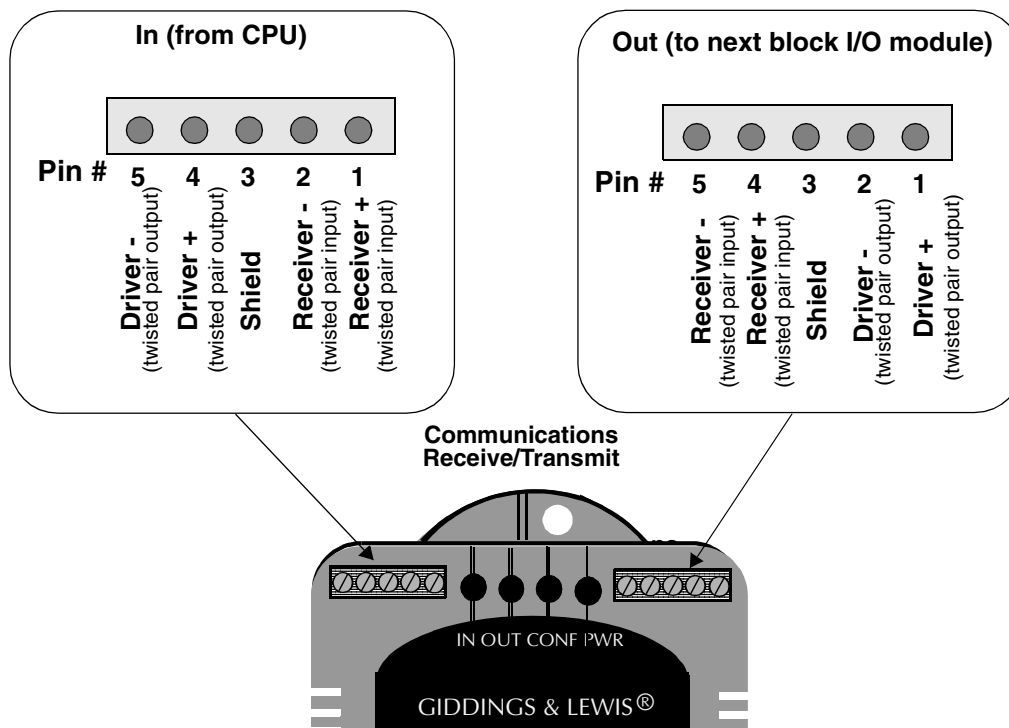

13.2.1.1 LEDs

LED	Color	State	Definition
DATA IN	Yellow	FAINT	Data being passed through the block module
		BRIGHT or OFF	No activity through the block module
DATA OUT	Yellow	FAINT	Data is being passed through the block module
		BRIGHT or OFF	No activity through the block module
CONFIG	Green	ON	Communication established with this block I/O module
		OFF	Communication not established
PWR	Green	ON	Internal +5V logic power supply OK
		OFF	No external 24V applied or internal 5V logic supply not OK

13.2.2 Analog Output Receiving Devices

It was assumed in Figure 13-2 that all the receiving device inputs were differential. However, you may connect the differential type output from this module to a single-ended input device. Figure 13-4 shows the difference between the two types of connections. Note that one wire in the twisted pair is connected to the 0 V terminal on the receiving device. This 0V terminal must be referenced to the SPG through the device's ground connection.

It is recommended that the receiving device have a differential input for best noise immunity.

Figure 13-4 Differential and Single-Ended Receiving Devices

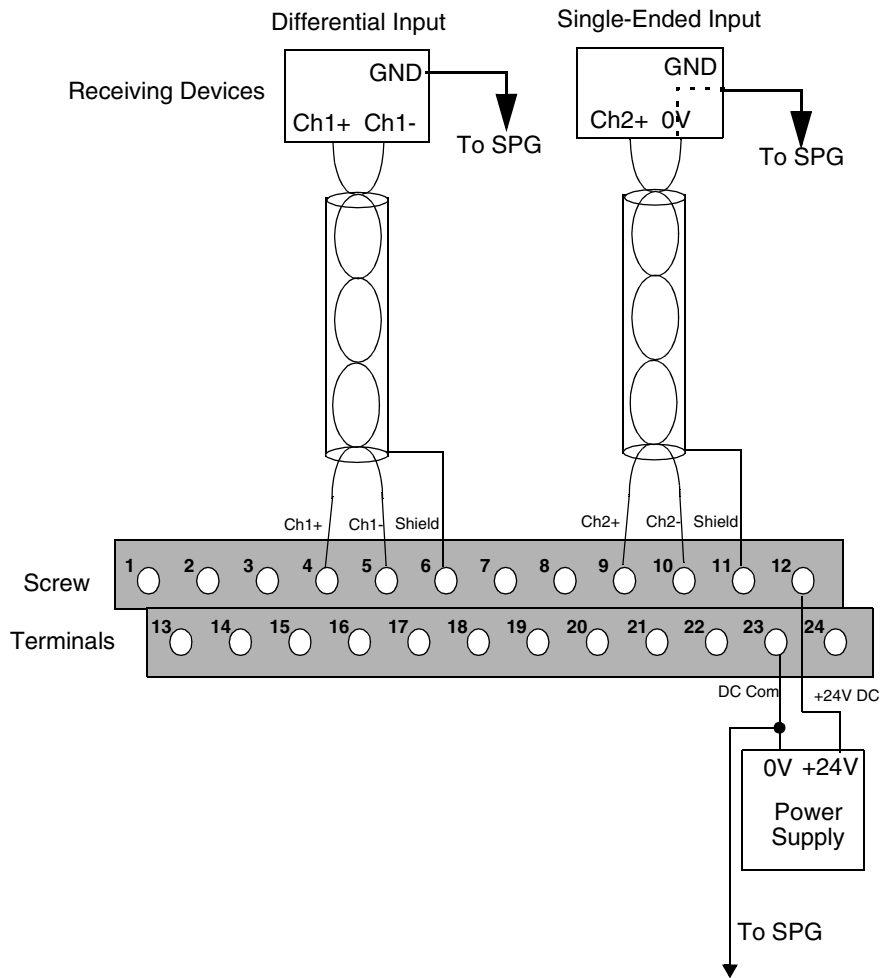

13.3 Theory of Operation

The CPU module sends the output module a 16-bit digital word for each channel used. Each digital word is converted to a corresponding voltage within the range of ± 10 V. The voltage is buffered and brought out to a pair of screw terminal connections as a differential type voltage output. This output is less subject to interference from electrical noise than a single-ended output would be.

You can adjust each channel in software for offset adjustments, gain scaling, and unipolar outputs.

For safety reasons, all outputs are automatically reset to 0 V when a scan loss condition occurs.

13.4 Specification Table

Characteristic	Output $\pm 10V$ DC module specification
Function	Converts a 16-bit digital word into a ± 10 V analog signal for each of the four channels.
Part number	M.1017.3140 (old # 503-25987-01)
Field side connector	24 pin card edge connector, screw terminals
Output channels	4
Resolution	16 bits, or 65536 steps over the full output range
Output voltage characteristics [@24V DC supply, with temperature = 25°C(77°F)]	
Nominal voltage range	± 10 VDC
Voltage accuracy	$\pm 1\%$ FSR (Full Scale Range)
Output current, max. @ $\pm 10V$	± 10 mA (1K Ω resistor)
Output voltage after power up	0 V \pm 50 mV
Response to scan loss	All outputs reset to 0 V \pm 50 mV
Short circuit protection	Current limited outputs
Logic side LEDs, module status	Data In LED Data Out LED Configured LED Power LED
Module power requirements	200 mA from an external 24V DC supply (20 to 30V DC range) NOTE: 2.5A, 250 microsecond inrush at power on

CE Marked	<p>Conforms to Directives 73/23/EEC, 89/336/EEC, 92/31/EEC, 93/68/EEC by conforming to the following standards:</p> <p>EN 50081-2:1993 EMC Generic Industrial Emissions EN 50082-2:1995 EMC Generic Industrial Immunity EN 61131-2:1994/A11:1996 Low voltage directive requirements for programmable controllers</p> <p>Operates with emissions below EN55011/ CISPR 11 Class A limits</p> <p>Immune to:</p> <ul style="list-style-type: none"> • Electrostatic discharge (4K V contact mode, 8K V air discharge) per EN61000-4-2 • RF electromagnetic fields per EN61000-4-3, ENV 50141, and ENV50204 • Electrical fast transients per EN61000-4-4 • Magnetic fields per EN61000-4-8 <p>Refer to the EMC Guidelines for more information.</p>
UL and C/UL Listed	File No. E126417 NQA Programmable Controllers
Operating temperature range	7° C to 55° C (45° F to 131° F)
Storage temperature range	-40° C to 85° C (-40° F to 185° F)
Humidity	5 to 95%, non-condensing
Physical size	4.05" wide x 4.825" high x 3" deep 102.9 mm x 122.6 mm x 76.2 mm
Vibration (per IEC 68-2-6)	10-57 Hz (constant amplitude .15 mm) 57 - 2000 Hz (acceleration 2 g)
Shock (per IEC 68-2-27)	Four shocks per axis (15g/11 msec)

NOTES

INDEX

Symbols

±10V DC

block output 13-1

±10V DC block output

connections 13-2

specifications 13-6

theory of operation 13-5

A

analog output receiving devices 13-4

B

block ±10V DC output

LEDs 13-3

block 24V DC 8/8 5-1

LEDs 5-1

specifications 5-10

block 4-20mA output 12-1

block analog input 11-1

connections 11-2, 11-4, 11-7, 12-4

analog output device 11-3

LEDs 11-7

specifications 11-9

theory of operation 11-8

block I/O

connections 3-4, 4-4, 5-5, 6-4, 7-6, 8-4

guidelines 2-1

LEDs 3-4, 4-4, 5-5, 6-4, 7-6, 8-4

safety 2-2

troubleshooting guide 2-6

wiring guidelines 2-3

block input 24V DC 4-1

connections 4-2

specifications 4-7

theory of operation 4-5, 5-7

block input connections 10-15

block output ±10V DC

connections 13-3

block output 24V DC source 3-1

connections 3-2

LEDs 3-1, 6-1

specifications 3-7

theory of operation 3-6

block output 4-20mA

LEDs 12-4

specifications 12-6

block output 4-20mA input

connections 12-2

block output 4-20mA Module

theory of operation 12-5

block output stepper/input encoder/

input24VDC

theory of operation 10-17

block resolver 9-7

connections 9-6

LEDs 9-6

block stepper 10-2

connections 10-3, 10-16

LEDs 10-16

specifications 10-22

theory of operation 10-17

C

clamping diode 12-5

common source

connections 10-7

drive inputs 10-7

common terminal 7-2

communications

connections

±10V DC block output 13-3

block analog input 11-7, 12-4

block I/O 3-4, 4-4, 5-5, 6-4, 7-6, 8-4

block resolver 9-6

block stepper 10-16

connections

±10V DC block output 13-2

block analog input 11-2

block input 10-15

block input 24V DC 4-2

block output 24V DC source 3-2

block output 4-20mA 12-2

block stepper 10-3

input 120V AC 8-2

output 120/240V AC 6-2

relay output 7-2

counter

up/down 10-19

current

leakage 4-6, 5-9, 8-6, 10-21

- sinking 4-2, 5-4
- sourcing 4-2, 5-4
- current output device 11-4
- current-limiting resistor 10-5

D

- D/A conversion channels
 - ±10V DC block output 13-1
- differential drivers 10-14
 - connections 10-10
 - inputs 10-10
- diode
 - clamping 12-5
 - input 10-5
- distribution of block I/O modules 2-5
- drivers
 - differential 10-10, 10-14
 - encoder 10-14
 - recommended 10-14
 - single-ended 10-8, 10-14

E

- electrical service & maintenance safety 1-6
- encoder
 - drivers 10-14
 - incremental 10-18
 - quadrature 10-18, 10-19

F

- feedback 9-3
- frequency 10-19

G

- grounding
 - protective earth 1-2
- guidelines
 - block I/O 2-1

I

- IEC 4-5, 5-7, 8-5, 10-20
- incremental
 - encoder 10-18
- inductive load 12-5
 - internal diode 3-5, 5-6
 - protection from 3-5, 5-6
- input 120V AC 8-1
 - connections 8-2

- LEDs 8-5
 - specifications 8-7
 - theory of operation 8-5
- input sensitivity
 - block analog input 11-8
- inspection
 - safety 1-4
- internal diode
 - and inductive loads 3-5, 5-6

K

- kickback 3-5, 5-6

L

- latch
 - counter value 10-19
- LEDs
 - block ±10V DC output 13-3
 - block 24V DC 8/8 5-1
 - block analog input 11-7
 - block I/O 3-4, 4-4, 5-5, 6-4, 7-6, 8-4
 - block input 24V DC 4-5, 5-7
 - block output 24V DC source 3-1, 6-1
 - block output 4-20mA 12-4
 - block resolver 9-6
 - block stepper 10-16, 10-20
 - input 120V AC 8-5
 - relay output 7-1, 7-8
- loss of feedback
 - detection 9-7, 10-14

M

- manual cleaning procedure 1-7
- modules
 - block 24V DC 8/8 5-1
 - block 4-20mA output 12-1
 - block analog input 11-1
 - block input 24V DC 4-1
 - block output ±10V DC 13-1
 - block output 24V DC source 3-1
 - block stepper 10-2
 - input 120V AC 8-1
 - relay output 7-1
 - resolver block input 9-1

N

- noise

- filter
 - block analog input 11-8
- normally closed 7-2, 7-7
- normally open 7-2, 7-7

O

- operation
 - safety 1-5
- opto-coupler
 - connections 10-6
 - drive inputs 10-5
- output 120/240V AC
 - connections 6-2
 - specifications 6-6
 - theory of operation 6-5

P

- peak reverse voltage 3-5, 5-6
- procedure
 - manual cleaning 1-7
- protective earth
 - grounding 1-2
- pull-up resistor 10-9

Q

- quadrature
 - counting pulses 10-19
 - encoder 10-18, 10-19
 - phase output 9-7

R

- receiving devices
 - analog output 13-4
 - differential 13-4
 - single-ended 13-4
- reference phase output 9-7
- relay output 7-1
 - connections 7-2
 - LEDs 7-1, 7-8
 - specifications 7-9
- relays
 - form A type 7-1, 7-2
 - form C type 7-1
 - common terminal 7-2
 - normally closed 7-2
 - normally open 7-2
- resistive load 3-5, 5-6

- resistor
 - current sensing 11-1
 - current-limiting 10-5
 - pull-up 10-9
- resolver block input 9-1
 - specifications 9-8
 - theory of operation 9-7
- rotor coil 9-7

S

- safety
 - cleaning 1-7
 - electrical service & maintenance 1-6
 - inspection 1-4
 - operation 1-5
 - signs 1-2
 - system 1-1
- safety concerns
 - block I/O 2-2
- signal
 - pairs 9-2, 10-12
 - sine wave 9-1, 9-7
 - square wave 10-18
- signs
 - safety 1-2
- sine wave signal 9-1, 9-7
- single-ended drivers 10-8, 10-14
- specifications
 - ± 10 V DC block output 13-6
 - block 24V DC 8/8 5-10
 - block analog input 11-9
 - block input 24V DC 4-7
 - block output 4-20mA 12-6
 - block output 24V DC source 3-7
 - block stepper 10-22
 - input 120V AC 8-7
 - output 120/240V AC 6-6
 - relay output 7-9
 - resolver block input 9-8
- square wave signal 10-18
- stator coil 9-7

T

- troubleshooting
 - block I/O 2-6

U

up/down counter 10-19

V

voltage

peak reverse 3-5, 5-6

W

warning labels 1-3

wiring

±10V DC block output 13-2

block analog input 11-2

block input 24V DC 4-2

block output 24V DC source 3-2

block output 4-20mA 12-2

input 120V AC 8-2

output 120/240V AC 6-2

relay output 7-2

wiring guidelines

block I/O 2-3