



## AKM

Deutsch	Synchron Servomotoren
English	Synchronous Servomotors
Italiano	Servomotori Sincroni
Español	Servomotores Sincronos

### Produkthandbuch / Product Manual / Manuale del Prodotto/ Manual del producto

Edition 12/2010

European Version (CE region)

Bewahren Sie das Handbuch als Produktbestandteil während der Lebensdauer des Produktes auf. Geben Sie das Handbuch an nachfolgende Benutzer oder Besitzer des Produktes weiter.

Conservare il manuale per l'intera durata del prodotto. In caso di cambio di proprietà il manuale deve essere fornito al nuovo utilizzatore quale parte integrante del prodotto.

Keep the manual as a product component during the life span of the product. Pass the manual to future users / owners of the product.

Conserve el manual durante toda la vida útil del producto. Entregue el manual a posteriores usuarios o propietarios del producto.



File akm\_deis.\*\*\*



**KOLLMORGEN**

## History

<b>Edition</b>	<b>Remarks</b>
01 / 2009	First multilingual edition
06 / 2010	Appendix renamed to Drawings, AKM8 added, symbols according to ANSI Z535, Hiperface added, minor corrections, technical data moved to appendix, new windings for AKM4 to 7, radial-/axial force diagrams new for AKM1 to 8
10 / 2010	Transport tool order information, wiring diagrams updated for H connector
12 / 2010	Weight data AKM8, derating AKM8, DIN 748 => EN 50347, company name&address

### **Technische Änderungen, die der Verbesserung der Geräte dienen, vorbehalten!**

Originalbetriebsanleitung, gedruckt in der BRD

Alle Rechte vorbehalten. Kein Teil des Werkes darf in irgendeiner Form (Druck, Fotokopie, Mikrofilm oder in einem anderen Verfahren) ohne schriftliche Genehmigung der Firma Kollmorgen Europe GmbH reproduziert oder unter Verwendung elektronischer Systeme verarbeitet, vervielfältigt oder verbreitet werden.

### **Technical changes to improve the performance of the equipment may be made without prior notice!**

Translation of the original manual, printed in the Federal Republic of Germany

All rights reserved. No part of this work may be reproduced in any form (by printing, photocopying, microfilm or any other method) or stored, processed, copied or distributed by electronic means without the written permission of Kollmorgen Europe GmbH.

### **Il produttore si riserva la facoltà di apportare modifiche tecniche volte al miglioramento degli apparecchi**

Traduzione del manuale originale, stampato nella Repubblica federale tedesca

Tutti i diritti riservati. Nessuna parte di questo documento può essere rielaborata, riprodotta in qualsiasi forma (stampa, fotocopia, microfilm o altro processo) o diffusa mediante l'uso di sistemi elettronici senza l'approvazione scritta della ditta Kollmorgen Europe GmbH o rielaborata, riprodotta o diffusa mediante l'uso di sistemi elettronici.

### **Reservado el derecho de introducir modificaciones técnicas para la mejora de los equipos**

Traducción del manual original, impreso en la RFA

Reservados todos los derechos. Prohibida la reproducción total o parcial de la presente obra por cualquier medio (impresión, fotocopia, microfilm u otros), así como su procesamiento, reproducción y divulgación por medio de sistemas electrónicos, sin expresa autorización escrita de la empresa Kollmorgen Europe GmbH.

<b>1</b>	<b>Allgemeines</b>	
1.1	Über dieses Handbuch.....	9
1.2	Zielgruppe .....	9
1.3	Verwendete Symbole.....	9
1.4	Verwendete Abkürzungen .....	9
<b>2</b>	<b>Sicherheit</b>	
2.1	Sicherheitshinweise .....	10
2.2	Bestimmungsgemäße Verwendung .....	11
2.3	Nicht bestimmungsgemäße Verwendung.....	11
<b>3</b>	<b>Gültige Standards</b>	
3.1	EG-Konformitätserklärung .....	12
<b>4</b>	<b>Handhabung</b>	
4.1	Transport .....	13
4.2	Verpackung .....	14
4.3	Lagerung .....	14
4.4	Wartung / Reinigung .....	14
4.5	Reparatur.....	14
4.6	Entsorgung.....	14
<b>5</b>	<b>Produktidentifizierung</b>	
5.1	Lieferumfang .....	15
5.2	Typenschild .....	15
5.3	Typenschlüssel .....	16
<b>6</b>	<b>Technische Beschreibung</b>	
6.1	Allgemeine technische Daten.....	17
6.2	Standardausrüstung.....	17
6.2.1	Bauform .....	17
6.2.2	Flansch .....	17
6.2.3	Schutzart .....	17
6.2.4	Isolierstoffklasse .....	17
6.2.5	Oberfläche .....	17
6.2.6	Wellenende A-Seite .....	18
6.2.7	Schutzeinrichtung .....	18
6.2.8	Schwinggüte .....	18
6.2.9	Haltebremse.....	18
<b>7</b>	<b>Mechanische Installation</b>	
7.1	Wichtige Hinweise .....	19
<b>8</b>	<b>Elektrische Installation</b>	
8.1	Sicherheitshinweise .....	20
8.2	Leitfaden für die elektrische Installation.....	20
8.3	Anschluss der Motoren mit vorkonfektionierten Kabeln .....	21
<b>9</b>	<b>Inbetriebnahme</b>	
9.1	Wichtige Hinweise .....	22
9.2	Leitfaden für die Inbetriebnahme .....	22
9.3	Beseitigen von Störungen .....	23
<b>10</b>	<b>Technische Daten</b>	
10.1	Begriffsdefinitionen.....	24

<b>11</b>	<b>General</b>	
11.1	About this manual	25
11.2	Target group	25
11.3	Symbols used	25
11.4	Abbreviations used	25
<b>12</b>	<b>Safety</b>	
12.1	Safety Notes	26
12.2	Use as directed	27
12.3	Prohibited use	27
<b>13</b>	<b>Standards</b>	
13.1	EC Declaration of Conformity	28
<b>14</b>	<b>Handling</b>	
14.1	Transport	29
14.2	Packaging	30
14.3	Storage	30
14.4	Maintenance / Cleaning	30
14.5	Repair	30
14.6	Disposal	30
<b>15</b>	<b>Package</b>	
15.1	Delivery package	31
15.2	Nameplate	31
15.3	Model number description	32
<b>16</b>	<b>Technical Description</b>	
16.1	General technical data	33
16.2	Standard features	33
16.2.1	Style	33
16.2.2	Flange	33
16.2.3	Protection class	33
16.2.4	Insulation material class	33
16.2.5	Surface	33
16.2.6	Shaft end, A-side	34
16.2.7	Protective device	34
16.2.8	Vibration class	34
16.2.9	Holding brake	34
<b>17</b>	<b>Mechanical Installation</b>	
17.1	Important Notes	35
<b>18</b>	<b>Electrical Installation</b>	
18.1	Safety notes	36
18.2	Guide for electrical installation	36
18.3	Connection of the motors with preassembled cables	37
<b>19</b>	<b>Setup</b>	
19.1	Important notes	38
19.2	Guide for setup	38
19.3	Trouble Shooting	39
<b>20</b>	<b>Technical Data</b>	
20.1	Definition of Terms	40

<b>21</b>	<b>Indicazioni generali</b>	
21.1	Questo manuale . . . . .	41
21.2	Gruppo di obiettivo . . . . .	41
21.3	Simboli utilizzati . . . . .	41
21.4	Abbreviazioni utilizzati . . . . .	41
<b>22</b>	<b>Sicurezza</b>	
22.1	Indicazioni di sicurezza . . . . .	42
22.2	Uso conforme . . . . .	43
22.3	Uso conforme vietato . . . . .	43
<b>23</b>	<b>Norme validi</b>	
23.1	EC Declaration of Conformity . . . . .	44
<b>24</b>	<b>Maneggiamento</b>	
24.1	Trasporto . . . . .	45
24.2	Imballaggio . . . . .	46
24.3	Stoccaggio . . . . .	46
24.4	Manutenzione / Puliza . . . . .	46
24.5	Riparazioni . . . . .	46
24.6	Smaltimento . . . . .	46
<b>25</b>	<b>Identificazione del prodotto</b>	
25.1	Dotazione . . . . .	47
25.2	Targhetta di omologazione . . . . .	47
25.3	Codici dei modelli . . . . .	48
<b>26</b>	<b>Descrizione tecnici</b>	
26.1	Dati tecnici generali . . . . .	49
26.2	Allestimento standard . . . . .	49
26.2.1	Forma costruttiva . . . . .	49
26.2.2	Flangia . . . . .	49
26.2.3	Grado di protezione . . . . .	49
26.2.4	Classe di isolamento . . . . .	49
26.2.5	Superficie . . . . .	49
26.2.6	Estremità di uscita albero . . . . .	50
26.2.7	Dispositivo di protezione . . . . .	50
26.2.8	Resistenza alle vibrazioni . . . . .	50
26.2.9	Freno di stazionamento . . . . .	50
<b>27</b>	<b>Installazione meccanica</b>	
27.1	Indicazioni importanti . . . . .	51
<b>28</b>	<b>Installazione elettrica</b>	
28.1	Indicazioni di sicurezza . . . . .	52
28.2	Guida ad installazione elettrica . . . . .	52
28.3	Collegamento dei motori . . . . .	53
<b>29</b>	<b>Messa in funzione</b>	
29.1	Indicazioni importanti . . . . .	54
29.2	Guida ad messa in funzione . . . . .	54
29.3	Eliminazione dei guasti . . . . .	55
<b>30</b>	<b>Dati tecnici</b>	
30.1	Definizioni . . . . .	56

<b>31</b>	<b>Generalidades</b>	
31.1	Sobre este manual . . . . .	57
31.2	Destinatarios . . . . .	57
31.3	Símbolos utilizados . . . . .	57
31.4	Abreviaturas utilizadas . . . . .	57
<b>32</b>	<b>Seguridad</b>	
32.1	Instrucciones de seguridad . . . . .	58
32.2	Utilización conforme . . . . .	59
32.3	Uso indebido . . . . .	59
<b>33</b>	<b>Normas válidas</b>	
33.1	EC Declaration of Conformity . . . . .	60
<b>34</b>	<b>Manipulación</b>	
34.1	Transporte . . . . .	61
34.2	Embalaje . . . . .	62
34.3	Almacenamiento . . . . .	62
34.4	Advertencia / Limpieza . . . . .	62
34.5	Reparación . . . . .	62
34.6	Eliminación . . . . .	62
<b>35</b>	<b>Identificación del producto</b>	
35.1	Volumen de suministro . . . . .	63
35.2	Placa de identificación . . . . .	63
35.3	Codificación de modelo . . . . .	64
<b>36</b>	<b>Descripción técnica</b>	
36.1	Datos técnicos generales . . . . .	65
36.2	Modelo estándar . . . . .	65
36.2.1	Forma de diseño . . . . .	65
36.2.2	Brida . . . . .	65
36.2.3	Tipo de protección . . . . .	65
36.2.4	Clase de material aislante . . . . .	65
36.2.5	Superficie . . . . .	65
36.2.6	Extremo del eje, lado de accionamiento . . . . .	66
36.2.7	Dispositivo protector . . . . .	66
36.2.8	Calidad vibracional . . . . .	66
36.2.9	Freno de detención . . . . .	66
<b>37</b>	<b>Instalación mecánica</b>	
37.1	Instrucciones importantes . . . . .	67
<b>38</b>	<b>Instalación eléctrica</b>	
38.1	Instrucciones de seguridad . . . . .	68
38.2	Guía de instalación eléctrica . . . . .	68
38.3	Conexión de los motores . . . . .	69
<b>39</b>	<b>Puesta en funcionamiento</b>	
39.1	Instrucciones importantes . . . . .	70
39.2	Guía de puesta en funcionamiento . . . . .	70
39.3	Eliminación de perturbaciones . . . . .	71
<b>40</b>	<b>Datos técnicos</b>	
40.1	Definiciones . . . . .	72

<b>41</b>	<b>Technical Data</b>	
41.1	Dictionary for technical data tables	74
41.2	Technical Data AKM1	75
41.3	Technical Data AKM2	76
41.4	Technical Data AKM3	77
41.5	Technical Data AKM4	78
41.6	Technical Data AKM5	80
41.7	Technical Data AKM6	82
41.8	Technical Data AKM7	84
41.9	Technical Data AKM8	85
<b>42</b>	<b>Dimension drawings</b>	
42.1	Dimensions/Radial Forces AKM1	87
42.2	Dimensions/Radial Forces AKM2	88
42.3	Dimensions/Radial Forces AKM3	89
42.4	Dimensions/Radial Forces AKM4	90
42.5	Dimensions/Radial Forces AKM5	91
42.6	Dimensions/Radial Forces AKM6	92
42.7	Dimensions/Radial Forces AKM7	93
42.8	Dimensions/Radial Forces AKM8	94
42.8.1	Dimensions AKM8x with terminal box	94
42.8.2	Dimensions AKM82 with power connector	95
42.8.3	Radial Forces AKM8	96
<b>43</b>	<b>Wiring diagrams</b>	
43.1	Wiring Diagram Motor & Resolver	97
43.2	Wiring Diagram Motor & Encoder with EnDat (ECx, EQx)	98
43.3	Wiring Diagram Motor & Smart Feedback Device (SFD)	99
43.4	Wiring Diagram Motor & ComCoder	100
43.5	Wiring Diagram Motor & Encoder with BISS	101
43.6	Wiring Diagram Motor & Encoder with Hiperface	102

Diese Seite wurde bewusst leer gelassen.



## 1 Allgemeines

### 1.1 Über dieses Handbuch

Dieses Handbuch beschreibt die Synchron-Servomotoren der Serie AKM (Standardausführung).

Die Motoren werden im Antriebssystem zusammen mit den Kollmorgen Servoverstärkern betrieben. Beachten Sie daher die gesamte Dokumentation des Systems, bestehend aus:

- Betriebsanleitung des Servoverstärkers
- Installations-/Inbetriebnahmeanweisung einer eventuell vorhandenen Erweiterungskarte
- Online Hilfe der Inbetriebnahmesoftware des Servoverstärkers
- Zubehörhandbuch
- Technische Beschreibung Motorserie AKM (dieses Handbuch)

Weitere Hintergrundinformationen finden Sie im "Produkt-WIKI", erreichbar unter [www.wiki-kollmorgen.eu](http://www.wiki-kollmorgen.eu).

### 1.2 Zielgruppe





Dieses Handbuch richtet sich mit folgenden Anforderungen an Fachpersonal:

- Transport: nur durch Personal mit Kenntnissen in der Behandlung elektrostatisch gefährdeter Bauelemente
- Mech. Installation: nur durch Fachleute mit maschinenbautechnischer Ausbildung
- Elektr. Installation: nur durch Fachleute mit elektrotechnischer Ausbildung
- Inbetriebnahme: nur durch Fachleute mit weitreichenden Kenntnissen in den Bereichen Elektrotechnik / Antriebstechnik

Das Fachpersonal muss folgende Normen kennen und beachten:  
IEC 60364 oder IEC 60664  
nationale Unfallverhütungsvorschriften

**⚠️ WARNUNG** Während des Betriebes der Motoren besteht die Gefahr von Tod oder schweren gesundheitlichen oder materiellen Schäden. Der Betreiber muss daher sicherstellen, dass die Sicherheitshinweise in diesem Handbuch beachtet werden. Der Betreiber muss sicherstellen, dass alle mit Arbeiten am Motor betrauten Personen das Produkthandbuch gelesen und verstanden haben.

### 1.3 Verwendete Symbole

Symbol	Bedeutung
	Weist auf eine gefährliche Situation hin, die, wenn sie nicht vermieden wird, zum Tode oder zu schweren, irreversiblen Verletzungen führen wird.
	Weist auf eine gefährliche Situation hin, die, wenn sie nicht vermieden wird, zum Tode oder zu schweren, irreversiblen Verletzungen führen kann.
	Weist auf eine gefährliche Situation hin, die, wenn sie nicht vermieden wird, zu leichten Verletzungen führen kann.
	Weist auf eine Situation hin, die, wenn sie nicht vermieden wird, zu Beschädigung von Sachen führen kann.
	Dies ist kein Sicherheits-Symbol. Dieses Symbol weist auf wichtige Informationen hin.

### 1.4 Verwendete Abkürzungen

Siehe Kapitel 10.1 "Begriffsdefinitionen".

## 2 Sicherheit

### 2.1 Sicherheitshinweise

#### **⚠️ WARNUNG**

- Der Maschinenhersteller muss eine Gefahrenanalyse für die Maschine erstellen und geeignete Maßnahmen treffen, dass unvorhergesehene Bewegungen nicht zu Schäden an Personen oder Sachen führen können.
- Stellen Sie unbedingt die ordnungsgemäße Erdung des Motorgehäuses mit der PE-Schiene im Schaltschrank als Bezugspotential sicher. Ohne niederohmige Erdung ist keine personelle Sicherheit gewährleistet.
- Ziehen Sie keine Stecker während des Betriebs. Es besteht die Gefahr von Tod oder schweren gesundheitlichen oder materiellen Schäden.
- Leistungsanschlüsse können Spannung führen, auch wenn sich der Motor nicht dreht. Lösen Sie die elektrischen Anschlüsse der Motoren nie unter Spannung. In ungünstigen Fällen können Lichtbögen entstehen und Personen und Kontakte schädigen.
- Warten Sie nach dem Trennen der Servoverstärker von den Versorgungsspannungen mehrere Minuten, bevor Sie spannungsführende Teile (z.B. Kontakte, Gewindebolzen) berühren oder Anschlüsse lösen. Kondensatoren im Servoverstärker führen mehrere Minuten nach Abschalten der Versorgungsspannungen gefährliche Spannungen. Messen Sie zur Sicherheit die Spannung im Zwischenkreis und warten Sie, bis die Spannung unter 40V abgesunken ist.
-  Während des Betriebes können Motoren ihrer Schutzart entsprechend heiße Oberflächen besitzen. Die Oberflächentemperatur kann 100°C überschreiten. Messen Sie die Temperatur und warten Sie, bis der Motor auf 40°C abgekühlt ist, bevor Sie ihn berühren.
- Entfernen/Sichern Sie eine eventuell vorhandene Wellen-Passfeder, falls der Motor frei läuft, um ein Wegschleudern der Passfeder und die damit verbundene Verletzungsgefahr zu vermeiden.
- Eingebaute Haltebremsen sind nicht personell sicher. Insbesondere bei hängender Last (Vertikalachsen) kann die personelle Sicherheit nur mit einer zusätzlichen, externen mechanischen Bremse erreicht werden.

#### **⚠️ VORSICHT**

- Nur qualifiziertes Fachpersonal darf Arbeiten wie Transport, Montage, Inbetriebnahme und Instandhaltung ausführen. Qualifiziertes Fachpersonal sind Personen, die mit Transport, Aufstellung, Montage, Inbetriebnahme und Betrieb von Motoren vertraut sind und über die ihrer Tätigkeit entsprechenden Qualifikationen verfügen. Das Fachpersonal muss folgende Normen bzw. Richtlinien kennen und beachten:  
IEC 60364 oder IEC 60664  
nationale Unfallverhütungsvorschriften
- Lesen Sie vor der Montage und Inbetriebnahme die vorliegende Dokumentation. Falsches Handhaben des Motors kann zu Personen- oder Sachschäden führen. Halten Sie die technischen Daten und die Angaben zu den Anschlussbedingungen (Typenschild und Dokumentation) unbedingt ein.

## 2.2

### Bestimmungsgemäße Verwendung

- Synchron-Servomotoren der Serie AKM sind insbesondere als Antrieb für Handhabungsgeräte, Textilmaschinen, Werkzeugmaschinen, Verpackungsmaschinen und ähnliche mit hohen Ansprüchen an die Dynamik konzipiert.
- Sie dürfen die Motoren **nur** unter Berücksichtigung der in dieser Dokumentation definierten Umgebungsbedingungen betreiben.
- Die Motoren der Serie AKM sind **ausschließlich** dazu bestimmt, von digitalen Servoverstärkern drehzahl- und/oder drehmomentgeregelt angesteuert zu werden.
- Die Motoren werden als Bauteile in elektrische Anlagen oder Maschinen eingebaut und dürfen nur als integrierte Bauteile der Anlage in Betrieb genommen werden.
- Der in die Motorwicklungen eingebaute Thermoschutzkontakt muss ausgewertet und überwacht werden.
- Eingebaute Haltebremsen sind als Stillstandsbremsen ausgelegt und für dauernde, betriebsmäßige Abbremsvorgänge ungeeignet.
- Die Konformität des Servosystems zu den in der EG-Konformitätserklärung auf Seite 12 genannten Normen garantieren wir nur, wenn von uns gelieferte Komponenten (Servoverstärker, Motor, Leitungen usw.) verwendet werden.

## 2.3

### Nicht bestimmungsgemäße Verwendung

- Der Betrieb der Motoren in folgenden Umgebungen ist verboten:
  - explosionsgefährdete Bereiche und Umgebungen mit ätzenden und/oder elektrisch leitenden Säuren, Laugen, Ölen, Dämpfen, Stäuben
  - direkt am Netz
- Der bestimmungsgemäße Betrieb des Motors ist untersagt, wenn die Maschine, in die er eingebaut wurde,
  - nicht den Bestimmungen der EG Maschinenrichtlinie entspricht
  - nicht die Bestimmung der EMV-Richtlinie erfüllt
  - nicht die Bestimmung der Niederspannungs-Richtlinie erfüllt
- Eingebaute Haltebremsen alleine dürfen nicht für die Sicherstellung der personellen Sicherheit benutzt werden.



## 4 Handhabung

### 4.1 Transport

- Transport-Temperatur: -25..+70°C, max. 20K/Stunde schwankend  
Transport-Luftfeuchtigkeit: relative Feuchte 5% - 95% nicht kondensierend
- Nur von qualifiziertem Personal in der recyclebaren Original-Verpackung des Herstellers
- Vermeiden Sie harte Stöße, insbesondere auf das Wellenende
- Überprüfen Sie bei beschädigter Verpackung den Motor auf sichtbare Schäden. Informieren Sie den Transporteur und gegebenenfalls den Hersteller.

Für den sicheren Transport der Motoren AKM8 sind beiliegende Hebeösen zu verwenden. Beachten Sie die in der Motorverpackung beiliegende Anweisungen für den Transport. Als Zubehör zum Transport der AKM8 Motoren empfehlen wir die Transportvorrichtung ZPMZ 120/292. Die Transportvorrichtung ZPMZ 120/292 besteht aus einer Traverse, die am Kranhaken eingehängt wird und zwei zweiadriigen Kettenanschlängen.



**Während des Hebevorgangs niemals unter die Last treten!**

- die Befestigungsschrauben der Hebeösen müssen vollständig eingedreht sein
- die Hebeösen müssen eben und vollflächig auf der Auflagefläche aufliegen
- Die Hebeösen vor dem Gebrauch auf festen Sitz und augenfällige Beschädigungen (Korrosion, Verformung) überprüfen.
- Hebeösen mit Verformungen dürfen nicht weiterbenutzt werden.

B1/ 4 x LIFTING BOLT PLUS LIFTING BEAM

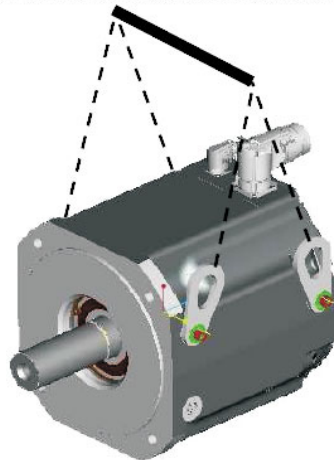

B2/ 2 x LIFTING BOLT PLUS LIFTING BEAM

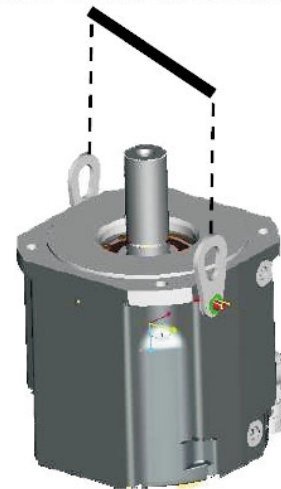

B3/ 2 x LIFTING BOLT PLUS LIFTING BEAM



## 4.2

**Verpackung**

- Kartonverpackung mit Instapak<sup>®</sup>-Ausschäumung.
- Den Kunststoffanteil können Sie an den Lieferanten zurückgeben (siehe "Entsorgung")

Motortyp	Verpackung	max. Stapelhöhe	Motortyp	Verpackung	max. Stapelhöhe
AKM1	Karton	10	AKM5	Karton	5
AKM2	Karton	10	AKM6	Karton	1
AKM3	Karton	6	AKM7	Karton	1
AKM4	Karton	6	AKM8	Mini-Palette	1

## 4.3

**Lagerung**

- Lagertemperatur -25...+55°C, max. 20K/Stunde schwankend
- Luftfeuchtigkeit relative Feuchte 5% - 95% nicht kondensierend
- Nur in der recyclebaren Originalverpackung des Herstellers lagern
- Max. Stapelhöhe: siehe Tabelle Verpackung
- Lagerdauer: ohne Einschränkung

## 4.4

**Wartung / Reinigung**

- Wartung und Reinigung nur von qualifiziertem Personal
- Nach 20.000 Betriebsstunden unter Nennbedingungen sollten die Kugellager erneuert werden (vom Hersteller).
- Prüfen Sie den Motor alle 2500 Betriebsstunden bzw. einmal jährlich auf Kugellagergeräusche. Wenn Sie Geräusche feststellen, darf der Motor nicht weiterbetrieben werden - die Lager müssen erneuert werden (vom Hersteller).
- Öffnen der Motoren bedeutet den Verlust der Gewährleistung.
- Gehäusereinigung mit Isopropanol o.ä., **nicht tauchen oder absprühen**

## 4.5

**Reparatur**

Reparaturen des Motors darf nur der Hersteller durchführen, Öffnen der Geräte bedeutet Verlust der Gewährleistung. Schicken Sie den Motor zur Reparatur an:

Kollmorgen Europe GmbH  
Pempelfurtstraße 1  
D-40880 Ratingen

## 4.6

**Entsorgung**

Gemäß der WEEE-2002/96/EG-Richtlinien nehmen wir Altgeräte und Zubehör zur fachgerechten Entsorgung zurück, sofern die Transportkosten vom Absender übernommen werden. Senden Sie die Geräte an:

Kollmorgen Europe GmbH  
Pempelfurtstraße 1  
D-40880 Ratingen

## 5 Produktidentifizierung

### 5.1 Lieferumfang

Sie erhalten einen Karton mit Instapak<sup>®</sup>-Ausschäumung. Enthalten ist:

- Motor der Serie AKM
- Produkthandbuch gedruckt, mehrsprachig

### 5.2 Typenschild

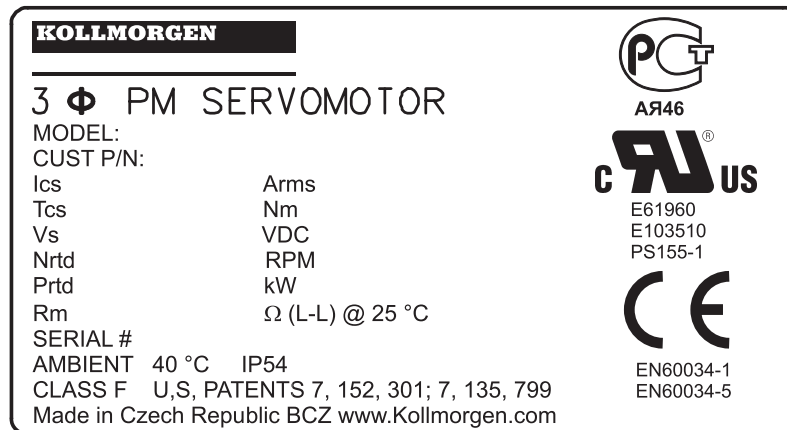

#### Legende:

MODEL	Typenbezeichnung
CUST P/N	Kunden-Mat.Nr
Ics	$I_{0rms}$ (Stillstandsstrom)
Tcs	$M_0$ (Stillstandsrehmoment)
Vs	$U_n$ (Zwischenkreisspannung)
Nrtd	nn (Nenndrehzahl bei $U_n$ )
Prtđ	Pn (Nennleistung)
Rm	R25 (Wicklungswiderstand bei 25°)
SERIAL	Seriennummer
AMBIENT	zul. Umgebungstemp.

Das Baujahr des Motors ist in der Seriennummer kodiert: die ersten beiden Ziffern der Seriennummer bezeichnen das Jahr, z.B. bedeutet "07" 2007.

5.3 Typenschlüssel

DEUTSCH

**AKM 6 2 P - A N C N DA 00**

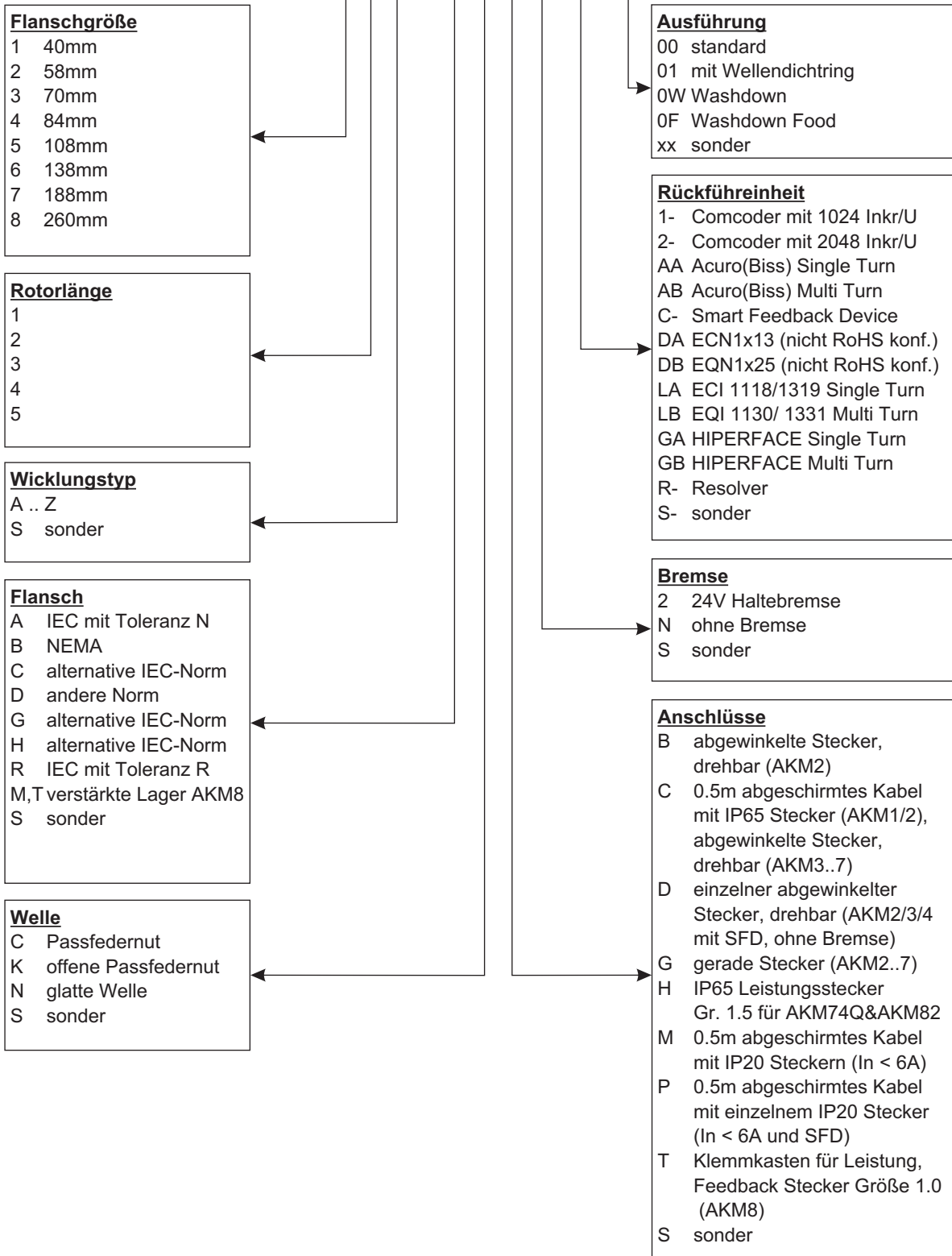



## 6 Technische Beschreibung

### 6.1 Allgemeine technische Daten

<b>Umgebungstemperatur (bei Nenndaten)</b>	5...+40°C bei Aufstellhöhe bis 1000m über NN Sprechen Sie bei Umgebungstemperaturen über 40°C und bei gekapseltem Einbau der Motoren unbedingt mit unserer Applikationsabteilung.
<b>Zulässige Luftfeuchte (bei Nenndaten)</b>	95% relative Feuchte, nicht betauend
<b>Leistungsreduzierung (Ströme und Momente)</b>	1%/K im Bereich 40°C...50°C bis 1000m über NN Bei Aufstellhöhen über 1000m über NN und 40°C 6% bei 2000m über NN 17% bei 3000m über NN 30% bei 4000m über NN 55% bei 5000m über NN Keine Leistungsreduzierung bei Aufstellhöhen über 1000m über NN und Temperaturreduzierung um 10K / 1000m
<b>Kugellager-Lebensdauer</b>	≥ 20.000 Betriebsstunden

#### INFO

Technische Daten zu jedem Motortyp finden Sie im Kapitel "Technical Data" ab Seite 74.

### 6.2 Standardausrüstung

#### 6.2.1 Bauform

Die Grundbauform der Synchron-Servomotoren AKM ist die Bauform IM B5 nach DIN EN 60034-7.

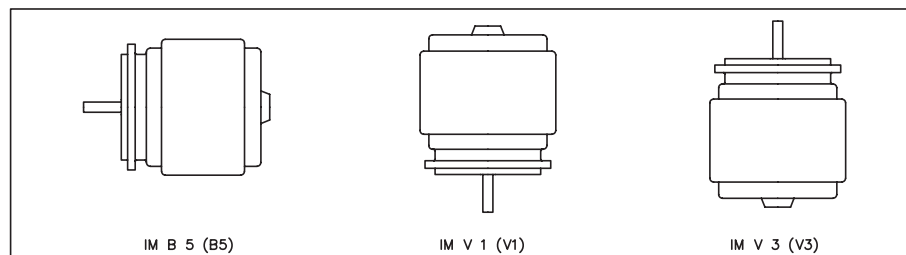

#### 6.2.2 Flansch

Flanschmaße nach IEC-Norm, Passung j6 (AKM1: h7), Genauigkeit nach DIN 42955  
Toleranzklasse : N, optional R für IEC Flansch

#### 6.2.3 Schutzart

Standardausführung AKM1-4 mit Anschluss M, P mit oder ohne Wellendichtring	IP20
Standardausführung AKM1 mit Anschluss C ohne Wellendichtring	IP40
Standardausführung AKM2-AKM8 mit Anschluss B, C, D, G, H, T ohne Wellendichtring	IP54
Standardausführung AKM1-AKM8 mit Anschluss B, C, D, G, H, T mit Wellendichtring	IP65

#### 6.2.4 Isolierstoffklasse

Die Motoren entsprechen der Isolierstoffklasse F nach IEC 60085 (UL 1446 class F).

#### 6.2.5 Oberfläche

Die Motoren sind mattschwarz mit Polyester pulverbeschichtet, eine Beständigkeit gegen Lösungsmittel (Tri, Verdünnung o.ä.) besteht nicht.

### 6.2.6 Wellenende A-Seite

Die Kraftübertragung erfolgt über das zylindrische Wellenende A, Passung k6 (AKM1: h7) nach EN50347 mit Anzugsgewinde aber **ohne Passfedernut**. Für die Lebensdauer der Lager sind 20.000 Betriebsstunden zugrunde gelegt.

#### Radialkraft

Treiben die Motoren über Ritzel oder Zahnriemen an, so treten hohe Radialkräfte auf. Die zugelassenen Werte am Wellenende abhängig von der Drehzahl entnehmen Sie den Diagrammen im Kapitel "Drawings" ab S.87. Die zugelassenen Maximalwerte finden Sie in den technischen Daten. Bei Kraftangriff an der Mitte des freien Wellenendes kann  $F_R$  10% größer sein.

#### Axialkraft

Bei der Montage von Ritzel oder Riemenscheiben auf die Welle und bei Betrieb von z.B. Winkelgetrieben treten Axialkräfte auf. Die zugelassenen Maximalwerte finden Sie in den technischen Daten.

#### Kupplung

Als ideale spielfreie Kupplungselemente haben sich doppelkonische Spannzangen eventuell in Verbindung mit Metallbalg-Kupplungen bewährt.

### 6.2.7 Schutzeinrichtung

In der Standardausführung ist jeder Motor mit einem potentialfreien PTC ausgestattet. Der Schalterpunkt liegt bei  $155^\circ\text{C} \pm 5\%$ . Schutz gegen kurzzeitige, sehr hohe Überlastung bietet der PTC **nicht**. Der PTC ist bei Verwendung unserer vorkonfektionierten Resolverleitung in das Überwachungssystem der digitalen Servoverstärker integriert.

### 6.2.8 Schwinggüte

Die Motoren sind in Schwinggüte A nach EN 60034-14 ausgeführt. Das bedeutet für einen Drehzahlbereich von 600-3600 U/min und einer Achshöhe zwischen 56-132mm eine zul. Schwingstärke von 1,6mm/s als Effektivwert.

Drehzahl [U/min]	max. rel. Schwingweg [ $\mu\text{m}$ ]	max. Run-out [ $\mu\text{m}$ ]
$\leq 1800$	90	23
$> 1800$	65	16

### 6.2.9 Haltebremse

Die Motoren AKM2-AKM8 sind wahlweise mit eingebauter Haltebremse erhältlich. Die Federdruckbremse (24V DC) blockiert im spannungslosen Zustand den Rotor.



#### WARNUNG

Bei hängender Last (Vertikalachsen) kann die **personelle Sicherheit nur mit einer zusätzlichen, externen mechanischen Bremse erreicht werden**.  
Ist die Bremse gelöst, kann sich der Rotor ohne Restmoment bewegen!



#### VORSICHT

Die Haltebremsen sind als Stillstandsbremsen ausgelegt und für dauernde, betriebsmäßige Abbremsvorgänge ungeeignet.  
Bei häufiger betriebsmäßiger Abbremsung ist ein vorzeitiger Verschleiß und Ausfall der Haltebremse wahrscheinlich.

Die Motorlänge vergrößert sich bei eingebauter Haltebremse.

Die Haltebremsen können direkt vom Servoverstärker angesteuert werden (nicht personell sicher!), dann erfolgt das Löschen der Bremswicklung im Servoverstärker — eine zusätzliche Beschaltung ist nicht erforderlich. Beachten Sie hierzu die Betriebsanleitung des Servoverstärkers.

Wird die Haltebremse nicht vom Servoverstärker direkt angesteuert, muss eine zusätzliche Beschaltung (z.B. Varistor) vorgenommen werden. Sprechen Sie hierzu mit unserem Kundendienst.

## 7 Mechanische Installation

### INFO

Maßzeichnungen finden Sie im Kapitel "Dimension Drawings" ab S.87.

### 7.1 Wichtige Hinweise

#### ⚠ VORSICHT

Nur Fachleute mit Maschinenbau-Kenntnissen dürfen den Motor montieren.

- Schützen Sie die Motoren vor unzulässiger Beanspruchung. Insbesondere dürfen bei Transport und Handhabung keine Bauelemente verbogen und / oder Isolationsabstände verändert werden
- Der Einbauort muss frei von leitfähigen und aggressiven Stoffen sein. Beachten Sie bei V3-Montage (Wellenende nach oben), dass keine Flüssigkeit in die Lager eindringen darf. Bei gekapseltem Einbau sollten Sie zunächst mit unserer Applikationsabteilung Rücksprache nehmen.
- Stellen Sie die ungehinderte Belüftung der Motoren sicher und beachten Sie die zulässige Umgebungs- und Flanschtemperatur. Bei Umgebungstemperaturen über 40°C sollten Sie zunächst mit unserer Applikationsabteilung Rücksprache nehmen.
- Servomotoren sind Präzisionsgeräte. Insbesondere Flansch und Welle sind bei Lagerung und Einbau gefährdet — vermeiden Sie daher rohe Kraftanwendung, Präzision verlangt Feingefühl. Benutzen Sie zum Aufziehen von Kupplungen, Zahnrädern oder Riemenscheiben unbedingt das vorgesehene Anzugsgewinde in der Motorwelle und erwärmen Sie, sofern möglich, die Abtriebs Elemente. Schläge oder Gewaltanwendung führen zur Schädigung von Kugellagern und Welle.

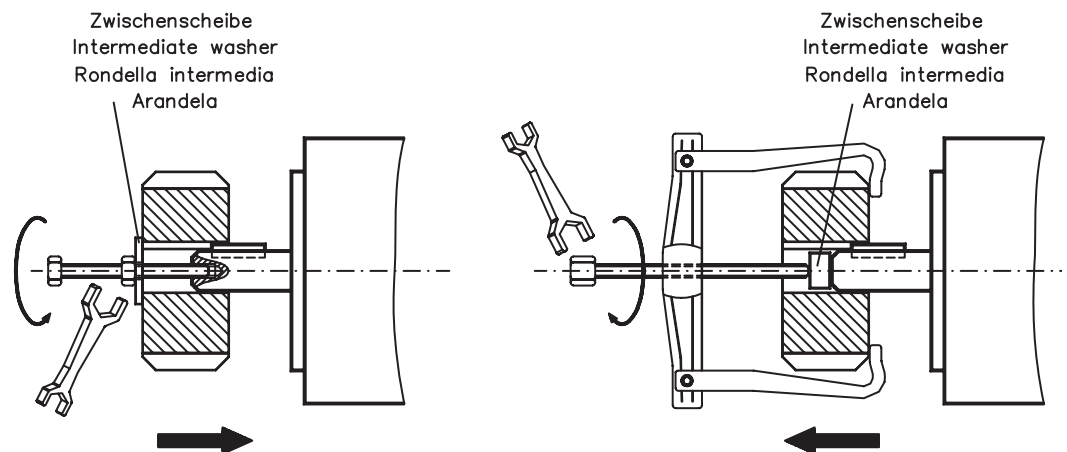

- Verwenden Sie nach Möglichkeit nur spielfreie, reibschlüssige Spannzangen oder Kupplungen. Achten Sie auf korrektes Ausrichten der Kupplung. Ein Versatz führt zu unzulässigen Vibrationen und zur Zerstörung von Kugellagern und Kupplung.
- Beachten Sie bei Anwendung von Zahnriemen unbedingt die zulässigen Radialkräfte. Zu hohe Radialbelastung der Welle verkürzt die Lebensdauer des Motors erheblich.
- Vermeiden Sie möglichst eine axiale Belastung der Motorwelle. Eine axiale Belastung verkürzt die Lebensdauer des Motors erheblich.
- Vermeiden Sie unter allen Umständen eine mechanisch überbestimmte Lagerung der Motorwelle durch starre Kupplung und externe Zusatzlagerung (z.B. im Getriebe).
- Beachten Sie die Motorpolzahl und die Resolverpolzahl und stellen Sie bei den verwendeten Servoverstärkern die Polzahlen unbedingt korrekt ein. Falsche Einstellung kann besonders bei kleinen Motoren zur Zerstörung führen.
- Prüfen Sie die Einhaltung der zulässigen Radial- und Axialbelastungen  $F_R$  und  $F_A$ . Bei Verwendung eines Zahnriemen-Antriebs ergibt sich der **minimal** zulässige Durchmesser des Ritzels z.B. nach der Gleichung:  $d_{\min} \geq \frac{M_0}{F_R} \times 2$ .

## 8 Elektrische Installation

### INFO

Anschlusspläne finden Sie im Kapitel "Wiring Diagrams" ab S.87 . Die Pinbelegung auf der Verstärkerseite finden Sie in der Betriebsanleitung des Servoverstärkers.

### 8.1 Sicherheitshinweise

#### ⚠️ WARNUNG

Nur Fachleute mit elektrotechnischer Ausbildung dürfen den Motor verdrahten.

Montieren und verdrahten Sie die Motoren immer im spannungsfreien Zustand, d.h. keine der Betriebsspannungen eines anzuschließenden Gerätes darf eingeschaltet sein. Sorgen Sie für eine sichere Freischaltung des Schaltschranks (Sperrschalter, Warnschilder etc.). Erst bei der Inbetriebnahme werden die einzelnen Spannungen eingeschaltet.

Lösen Sie die elektrischen Anschlüsse der Motoren nie unter Spannung.

Restladungen in den Kondensatoren des Servoverstärkers können auch mehrere Minuten nach Abschalten der Netzspannung gefährliche Werte aufweisen.

Messen Sie die Spannung im Zwischenkreis und warten Sie, bis die Spannung unter 40V abgesunken ist. Steuer- und Leistungsanschlüsse können Spannung führen, auch wenn sich der Motor nicht dreht.

### INFO

Das Masse-Zeichen  $\text{---}$ , das Sie in allen Anschlussplänen finden, deutet an, dass Sie für eine möglichst großflächige, elektrisch leitende Verbindung zwischen dem gekennzeichneten Gerät und der Montageplatte in Ihrem Schaltschrank sorgen müssen. Diese Verbindung soll die Ableitung von HF-Störungen ermöglichen und ist nicht zu verwechseln mit dem PE-Zeichen (Schutzmaßnahme nach EN 60204).

Beachten Sie auch die Hinweise in den Anschlussplänen in der Betriebsanleitung des verwendeten Servoverstärkers.

### 8.2 Leitfaden für die elektrische Installation

- Prüfen Sie die Zuordnung von Servoverstärker und Motor. Vergleichen Sie Nennspannung und Nennstrom der Geräte. Führen Sie die Verdrahtung nach dem Anschlussbild in der Betriebsanleitung des Servoverstärkers aus. Die Anschlüsse des Motors sind im Kapitel "Wiring Diagrams" ab S.87 dargestellt.
- Achten Sie auf einwandfreie Erdung von Servoverstärker und Motor. EMV-gerechte Abschirmung und Erdung siehe Betriebsanleitung des verwendeten Servoverstärkers. Erden Sie Montageplatte und Motorgehäuse.
- Verlegen Sie Leistungs- und Steuerkabel möglichst getrennt (Abstand > 20 cm). Die elektromagnetische Verträglichkeit des Systems wird so verbessert. Bei Verwendung eines Motorleistungskabels mit integrierten Bremssteueradern müssen die Bremssteueradern abgeschirmt sein. Der Schirm muss beidseitig aufgelegt werden (siehe auch Betriebsanleitung des Servoverstärkers).
- Verdrahtung:
  - Leistungs- und Steuerkabel möglichst getrennt verlegen
  - Resolver bzw. Encoder anschließen
  - Motorleitungen anschließen Motordrossel nahe am Servoverstärker
  - Abschirmungen beidseitig auf Schirmklemmen bzw. EMV-Stecker
  - Motor-Haltesbremse anschließen
  - Abschirmung beidseitig auflegen
- Verlegen Sie sämtliche starkstromführenden Leitungen in ausreichendem Querschnitt nach EN 60204. Die empfohlenen Querschnitte finden Sie in den technischen Daten.
 

**Abhängig vom Typ des verwendeten Servoverstärkers muss bei langen Motorleitung (> 25m) eine Motordrossel (3YL oder 3YLN) in die Motorleitung geschaltet werden (siehe Betriebsanleitung des Servoverstärkers und Zubehörhandbuch).**
- Legen Sie Abschirmungen großflächig (niederohmig) über metallisierte Steckergehäuse bzw. EMV-gerechte Kabelverschraubungen auf.

### INFO

### 8.3 Anschluss der Motoren mit vorkonfektionierten Kabeln

**INFO**

Anschlusspläne finden Sie im Kapitel "Wiring Diagrams" ab S.87.

- Führen Sie die Verdrahtung gemäß den geltenden Vorschriften und Normen aus.
- Verwenden Sie für Leistungs- und Rückführanschluss ausschließlich unsere vorkonfektionierten, abgeschirmten Leitungen.
- Legen Sie die Abschirmungen entsprechend den Anschlussbildern in der Betriebsanleitung des Servoverstärkers auf.
- Nicht korrekt aufgelegte Abschirmungen führen unweigerlich zu EMV-Störungen.
- Die maximale Leitungslänge ist in der Betriebsanleitung des verwendeten Servoverstärkers definiert.

Anforderungen an das Leitungsmaterial:

**Kapazität**

Motorleitung: kleiner als 150 pF/m

Feedback-Leitung: kleiner als 120 pF/m

**INFO**

Technische Daten unserer konfektionierten Leitungen finden Sie im Zubehörhandbuch.

## 9 Inbetriebnahme

### 9.1 Wichtige Hinweise

**⚠️ WARNUNG**

- Nur Fachleute mit weitreichenden Kenntnissen in den Bereichen Elektrotechnik /Antriebstechnik dürfen die Antriebseinheit Servoverstärker/Motor in Betrieb nehmen.
- Prüfen Sie, ob alle spannungsführenden Anschlusssteile gegen Berührung sicher geschützt sind. Es treten lebensgefährliche Spannungen bis zu 900V auf.
- Lösen Sie die elektrischen Anschlüsse der Motoren nie unter Spannung. Restladungen in Kondensatoren der Servoverstärker können mehrere Minuten nach Abschalten der Netzspannung gefährliche Werte aufweisen.
- Die Oberflächentemperatur des Motors kann im Betrieb 100°C überschreiten. Prüfen (messen) Sie die Temperatur des Motors. Warten Sie, bis der Motor auf 40°C abgekühlt ist, bevor Sie ihn berühren.
- Stellen Sie sicher, dass auch bei ungewollter Bewegung des Antriebs keine maschinelle oder personelle Gefährdung eintreten kann.

### 9.2 Leitfaden für die Inbetriebnahme

Das Vorgehen bei der Inbetriebnahme wird exemplarisch beschrieben.

Je nach Einsatz der Geräte kann auch ein anderes Vorgehen sinnvoll und erforderlich sein.

- Prüfen Sie Montage und Ausrichtung des Motors.
- Prüfen Sie die Abtriebs Elemente (Kupplung, Getriebe, Riemenscheibe) auf festen Sitz und korrekte Einstellung (zulässige Radial- und Axialkräfte beachten).
- Prüfen Sie die Verdrahtung und Anschlüsse an Motor und Servoverstärker. Achten Sie auf ordnungsgemäße Erdung.
- Prüfen Sie die Funktion der Haltebremse, sofern vorhanden. (24V anlegen, Bremse muss lüften).
- Prüfen Sie, ob der Rotor des Motors sich frei drehen lässt (eventuell vorhandene Bremse vorher lüften). Achten Sie auf Schleifgeräusche.
- Prüfen Sie, ob alle erforderlichen Berührungsschutz-Maßnahmen für bewegte und spannungsführende Teile getroffen wurden.
- Führen Sie weitere für Ihre Anlage spezifischen und notwendigen Prüfungen durch.
- Nehmen Sie nun entsprechend der Inbetriebnahmeanweisung des Servoverstärkers den Antrieb in Betrieb.
- Nehmen Sie bei Mehrachs-Systemen jede Antriebseinheit Servoverstärker/Motor einzeln in Betrieb.

### 9.3 Beseitigen von Störungen

Abhängig von den Bedingungen in Ihrer Anlage können vielfältige Ursachen für die auftretende Störung verantwortlich sein. Beschrieben werden vorwiegend die Fehlerursachen, die den Motor direkt betreffen. Auftretende Auffälligkeiten im Regelverhalten haben meist ihre Ursache in fehlerhafter Parametrierung des Servoverstärkers. Informieren Sie sich hierzu in der Dokumentation des Servoverstärkers und der Inbetriebnahmesoftware.

Bei Mehrachssystemen können weitere versteckte Fehlerursachen vorliegen.

Unser Kundendienst hilft Ihnen bei Problemen weiter.

Fehler	mögliche Fehlerursachen	Maßnahmen zur Beseitigung der Fehlerursachen
<b>Motor dreht nicht</b>	<ul style="list-style-type: none"> <li>— Servoverstärker nicht freigegeben</li> <li>— Sollwertleitung unterbrochen</li> <li>— Motorphasen vertauscht</li> <li>— Bremse ist nicht gelöst</li> <li>— Antrieb ist mechanisch blockiert</li> </ul>	<ul style="list-style-type: none"> <li>— ENABLE-Signal anlegen</li> <li>— Sollwertleitung prüfen</li> <li>— Motorphasen korrekt auflegen</li> <li>— Bremsenansteuerung prüfen</li> <li>— Mechanik prüfen</li> </ul>
<b>Motor geht durch</b>	<ul style="list-style-type: none"> <li>— Motorphasen vertauscht</li> </ul>	<ul style="list-style-type: none"> <li>— Motorphasen korrekt auflegen</li> </ul>
<b>Motor schwingt</b>	<ul style="list-style-type: none"> <li>— Abschirmung Resolverleitung unterbrochen</li> <li>— Verstärkung zu groß</li> </ul>	<ul style="list-style-type: none"> <li>— Resolverleitung erneuern</li> <li>— Motordefaultwerte verwenden</li> </ul>
<b>Fehlermeldung Bremse</b>	<ul style="list-style-type: none"> <li>— Kurzschluss in der Spannungszuleitung der Motorhaltebremse</li> <li>— defekte Motorhaltebremse</li> </ul>	<ul style="list-style-type: none"> <li>— Kurzschluss beseitigen</li> <li>— Motor tauschen</li> </ul>
<b>Fehlermeldung Endstufenfehler</b>	<ul style="list-style-type: none"> <li>— Motorleitung hat einen Kurz-/Erdschluss</li> <li>— Motor hat einen Kurz- oder Erdschluss</li> </ul>	<ul style="list-style-type: none"> <li>— Kabel tauschen</li> <li>— Motor tauschen</li> </ul>
<b>Fehlermeldung Resolver</b>	<ul style="list-style-type: none"> <li>— Resolverstecker ist nicht richtig aufgesteckt</li> <li>— Resolverleitung ist unterbrochen, gequetscht o.ä.</li> </ul>	<ul style="list-style-type: none"> <li>— Steckverbindung überprüfen</li> <li>— Leitungen überprüfen</li> </ul>
<b>Fehlermeldung Motortemperatur</b>	<ul style="list-style-type: none"> <li>— Motorthermoschalter hat angesprochen</li> <li>— Resolverstecker lose oder Resolverleitung unterbrochen</li> </ul>	<ul style="list-style-type: none"> <li>— Abwarten bis Motor abgekühlt ist. Danach überprüfen, warum der Motor so heiß wird.</li> <li>— Stecker prüfen, eventuell neue Resolverleitung einsetzen</li> </ul>
<b>Bremse greift nicht</b>	<ul style="list-style-type: none"> <li>— Gefordertes Haltemoment zu hoch</li> <li>— Bremse defekt</li> <li>— Motorwelle axial überlastet</li> </ul>	<ul style="list-style-type: none"> <li>— Auslegung überprüfen</li> <li>— Motor tauschen</li> <li>— Axialbelastung überprüfen und verringern. Motor tauschen, da die Lager beschädigt sind</li> </ul>

## 10 Technische Daten

### INFO

Technische Daten zu jedem Motortyp finden Sie im Kapitel "Technical Data" ab Seite 74.

Alle Angaben bei 40°C Umgebungstemperatur und 100K Wicklungsübertemperatur.  
Die Daten können eine Toleranz von +/- 10% aufweisen.

### 10.1 Begriffsdefinitionen

#### Stillstands Drehmoment $M_0$ [Nm]

Das Stillstands Drehmoment kann bei Drehzahl  $0 < n < 100 \text{ min}^{-1}$  und Nenn-Umgebungsbedingungen unbegrenzt lange abgegeben werden.

#### Nenn Drehmoment $M_n$ [Nm]

Das Nenn Drehmoment wird abgegeben, wenn der Motor bei Nenndrehzahl Nennstrom aufnimmt. Das Nenn Drehmoment kann im Dauerbetrieb (S1) bei Nenndrehzahl unbegrenzt lange abgegeben werden.

#### Stillstandsstrom $I_{0rms}$ [A]

Der Stillstandsstrom ist der Sinus-Effektiv-Stromwert, den der Motor bei  $0 < n < 100 \text{ min}^{-1}$  aufnimmt, um das Stillstands Drehmoment abgeben zu können.

#### Spitzenstrom (Impulsstrom) $I_{0max}$ [A]

Der Spitzenstrom (Sinus-Effektivwert) entspricht ca. dem 5-fachen Stillstandsstrom. Der Spitzenstrom des verwendeten Servoverstärkers muss kleiner sein.

#### Drehmomentkonstante $K_{Trms}$ [Nm/A]

Die Drehmomentkonstante gibt an, wie viel Drehmoment in Nm der Motor mit 1A Sinus-Effektivstrom erzeugt. Es gilt  $M = I \times K_T$  (bis maximal  $I = 2 \times I_0$ )

#### Spannungskonstante $K_{Erms}$ [mV/min]

Die Spannungskonstante gibt die auf 1000U/min bezogene induzierte Motor EMK als Sinus-Effektivwert zwischen zwei Klemmen an.

#### Rotorträgheitsmoment $J$ [kgcm<sup>2</sup>]

Die Konstante J ist ein Maß für das Beschleunigungsvermögen des Motors. Mit  $I_0$  ergibt sich z.B. die Beschleunigungszeit  $t_b$  von 0 bis  $3000 \text{ min}^{-1}$  zu :

$$t_b [\text{s}] = \frac{3000 \times 2\pi}{M_0 \times 60\text{s}} \times \frac{m^2}{10^4 \times \text{cm}^2} \times J \quad \text{mit } M_0 \text{ in Nm und } J \text{ in kgcm}^2$$

#### Thermische Zeitkonstante $t_{th}$ [min]

Die Konstante  $t_{th}$  gibt die Erwärmungszeit des kalten Motors bei Belastung mit  $I_0$  bis zum Erreichen von  $0,63 \times 100$  Kelvin Übertemperatur an.

Bei Belastung mit Spitzenstrom erfolgt die Erwärmung in wesentlich kürzerer Zeit.

#### Lüftverzögerungszeit $t_{BRH}$ [ms] / Einfallverzögerungszeit $t_{BRL}$ [ms] der Bremse

Die Konstanten geben die Reaktionszeiten der Haltebremse bei Betrieb mit Nennspannung am Servoverstärker an.

#### $U_N$

Netzennspannung

#### $U_n$

Zwischenkreisspannung.  $U_n = \sqrt{2} * U_N$



## 11 General

### 11.1 About this manual

This manual describes the AKM series of synchronous servomotors (standard version). Among other things, you find information about:

The motors are operated in drive systems together with Kollmorgen servo amplifiers. Please observe the entire system documentation, consisting of:

- Instructions manual for the servo amplifier
- Installation and setup instructions for any expansion card which is connected
- Online help of the amplifier's setup software
- Accessories manual
- Technical description of the AKM series of motors

More background information can be found in our "Product WIKI", available at [www.wiki-kollmorgen.eu](http://www.wiki-kollmorgen.eu).

### 11.2 Target group

This manual addresses personnel with the following qualifications:





- Transport : only by personnel with knowledge of handling electrostatically sensitive components.
- Mech. Installation : only by mechanically qualified personnel.
- Electr. Installation : only by electrically qualified personnel.
- Setup : only by qualified personnel with extensive knowledge of electrical engineering and drive technology

The qualified personnel must know and observe the following standards:

- IEC 60364 or IEC 60664
- national accident prevention regulations

**⚠ WARNING** The operator must ensure that the safety instructions in this manual are followed. The operator must ensure that all personnel responsible for working with the motor have read and understood the product manual.

### 11.3 Symbols used

Symbol	Indication
	Indicates a hazardous situation which, if not avoided, will result in death or serious injury.
	Indicates a hazardous situation which, if not avoided, could result in death or serious injury.
	Indicates a hazardous situation which, if not avoided, could result in minor or moderate injury.
	Indicates situations which, if not avoided, could result in property damage.
	This is not a safety symbol. This symbol indicates important notes.

### 11.4 Abbreviations used

see chapter 20.1 "Definition of Terms".

# 12 Safety

## 12.1 Safety Notes

### **⚠ WARNING**

- The manufacturer of the machine must generate a hazard analysis for the machine, and take appropriate measures to ensure that unforeseen movements cannot cause injury or damage to any person or property.
- It is vital that you ensure that the motor housing is safely earthed to the PE(protective earth) busbar in the switch cabinet. Electrical safety is impossible without a low-resistance earth connection.
- Do not unplug any connectors during operation. This creates the danger of death, severe injury, or extensive material damage.
- Power connections may be live even when the motor is not rotating. Never disconnect the power connections of the motor while the equipment is energised. This can cause flashovers with resulting injuries to persons and damage to the contacts.
- After disconnecting the servo amplifier from the supply voltage, wait several minutes before touching any components which are normally live (e.g. contacts, screw connections) or opening any connections.  
The capacitors in the servo amplifier can still carry a dangerous voltage several minutes after switching off the supply voltages. To be quite safe, measure the DC-link voltage and wait until the voltage has fallen below 40V.
-  The surfaces of the motors can be very hot in operation, according to their protection category. The surface temperature can exceed 100°C. Measure the temperature, and wait until the motor has cooled down below 40°C before touching it.
- Remove any fitted key (if present) from the shaft before letting the motor run independently, to avoid the dangerous results of the key being thrown out by centrifugal forces.
- Built-in holding brakes do not ensure personnel safety! Hanging loads (vertical axes) require an additional, external mechanical brake to ensure personnel safety.

### **⚠ CAUTION**

- Only properly qualified personnel are permitted to perform such tasks as transport, assembly, setup and maintenance. Properly qualified personnel are persons who are familiar with the transport, assembly, installation, setup and operation of motors, and who have the appropriate qualifications for their jobs. The qualified personnel must know and observe the following standards and regulations:  
IEC 60364 or IEC 60664  
national regulations for safety / accident prevention
- Read the available documentation before assembly and setup. Incorrect handling of the motors can result in injury and damage to persons and machinery. Keep strictly to the technical data and the information on the connection requirements (nameplate and documentation).

## 12.2

### Use as directed

- The AKM series of synchronous servomotors is designed especially for drives for industrial robots, machine tools, textile and packing machinery and similar with high requirements for dynamics.
- The user is **only** permitted to operate the motors under the ambient conditions which are defined in this documentation.
- The AKM series of motors is **exclusively** intended to be driven by servo amplifiers under speed and / or torque control.
- The motors are installed as components in electrical apparatus or machines and can only be commissioned and put into operation as integral components of such apparatus or machines.
- The thermal contact which is integrated in the motor windings must be observed and evaluated.
- The holding brakes are designed as standstill brakes and are not suited for repeated operational braking.
- The conformity of the servo-system to the standards mentioned in the EC Declaration of Conformity on page 28 is only guaranteed when the components (servo amplifier, motor, cables etc.) that are used have been supplied by us.

## 12.3

### Prohibited use

- The use of the motors in the following environments is prohibited:
  - potentially explosive areas
  - environments with corrosive and/or electrically conductive acids, alkaline solutions, oils, vapours, dusts
  - directly on supply networks
- Commissioning the motor is prohibited if the machine in which it was installed
  - does not meet the requirements of the EC Machinery Directive
  - does not comply with the EMC Directive
  - does not comply with the Low Voltage Directive
- Built-in holding brakes without further equipment must not be used to ensure personnel safety.

**13 Standards****13.1 EC Declaration of Conformity**

We, the company  
Kollmorgen Europe GmbH  
Pempelfurtstraße 1  
D-40880 Ratingen

hereby in sole responsibility declare the conformity of the product series

**Motor series AKM**  
**(Types AKM1, AKM2, AKM3, AKM4, AKM5, AKM6, AKM7, AKM8)**

with the following standards:

- EC Directive 2004/108/EC  
Electromagnetic compatibility  
Used standard EN61800-3:07/2005
- EC Directive 2006/95/EC  
Electrical devices for use in special voltage limits  
Used standard EN61800-5-1:04/2008

Year of EC-Declaration      2003

Issued by:                      Product Manager Motors Europe  
   Jörg Peters  
   Ratingen, 01.12.2010

Legally valid signature



This Declaration does not contain any assurance of properties in the meaning of product liability.  
The notes on safety and protection in the operating instructions must always be observed.  
The above-mentioned company has the following technical documentation for examination:

- Proper operating instructions
- Diagrams (for EU authority only)
- Test certificates (for EU authority only)
- Other technical documentation (for EU authority only)

## 14 Handling

### 14.1 Transport

- Transport temperature -25...+70°C, max. 20K/hr change
- Transport humidity rel. humidity 5% - 95% , no condensation
- Only by qualified personnel in the manufacturer's original recyclable packaging
- Avoid shocks, especially to the shaft end
- If the packaging is damaged, check the motor for visible damage. Inform the carrier and, if appropriate, the manufacturer.

Lifting eyes are used to safely transport AKM8 motors. Please observe any transport instructions included in the packaging of the motor. We recommend the transport tool ZPZM 120/292 for moving the AKM8 motors. Suspension Unit ZPMZ 120/292 consists of a beam, suspended to the crane hook and two double-run chain suspenders.

**⚠ DANGER** Never step under the load, while the motor is raised.

- The fastening screws of the lifting eyes must be fully screwed in.
- The lifting eyes must be positioned on the supporting surface in an even and flat manner.
- Prior to use, check the lifting eyes for secure fitting and any obvious damages (corrosion, deformation).
- Lifting eyes with deformations must not continue to be used.

B1/ 4 x LIFTING BOLT PLUS LIFTING BEAM

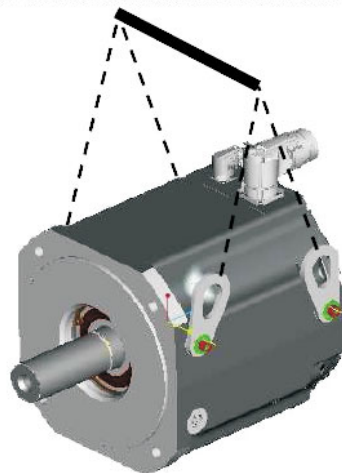

B2/ 2 x LIFTING BOLT PLUS LIFTING BEAM



B3/ 2 x LIFTING BOLT PLUS LIFTING BEAM



## 14.2 Packaging

- Cardboard packing with Instapak<sup>®</sup> foam cushion.
- You can return the plastic portion to the supplier (see "Disposal").

Motor type	Packing	Max.stacking height	Motor type	Packing	Max.stacking height
AKM1	Cardboard	10	AKM5	Cardboard	5
AKM2	Cardboard	10	AKM6	Cardboard	1
AKM3	Cardboard	6	AKM7	Cardboard	1
AKM4	Cardboard	6	AKM8	Pallet	1

## 14.3 Storage

- Storage temperature - 25...+55°C, max. variation 20K/hr.
- Humidity rel. humidity 5% - 95%, no condensation
- Store only in the manufacturer's original recyclable packaging
- Max. stacking height see table under Packaging
- Storage time unlimited

## 14.4 Maintenance / Cleaning

- Maintenance and cleaning only by qualified personnel
- The ball bearings should be replaced after 20,000 hours of operation under rated conditions (by the manufacturer).
- Check the motor for bearing noise every 2500 operating hours, respectively each year. If any noises are heard, stop the operation of the motor, the bearings must be replaced (by the manufacturer).
- Opening the motor invalidates the warranty.
- If the housing is dirty, clean housing with Isopropanol or similar, **do not immerse or spray**

## 14.5 Repair

Repair of the motor must be done by the manufacturer. Opening the motor invalidates the warranty. Send the motor to:

Kollmorgen Europe GmbH  
Pempelfurtstraße 1  
D-40880 Ratingen

## 14.6 Disposal

In accordance to the WEEE-2002/96/EG-Guidelines we take old devices and accessories back for professional disposal, if the transport costs are taken over by the sender. Send the devices to:

Kollmorgen Europe GmbH  
Pempelfurtstraße 1  
D-40880 Ratingen

## 15 Package

### 15.1 Delivery package

- Motor from the AKM series
- Product manual (multi language)

### 15.2 Nameplate

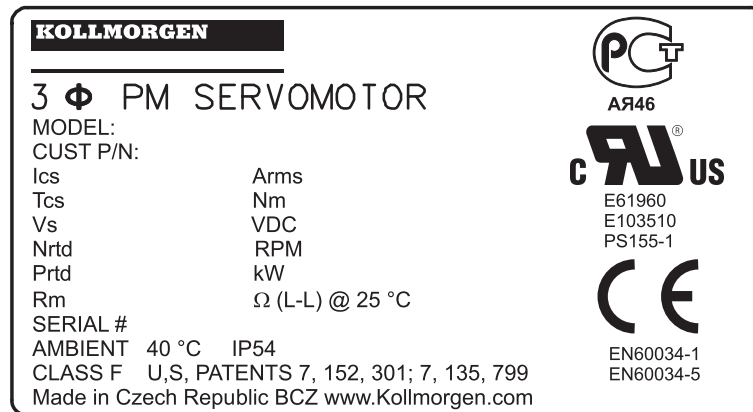

#### Legend:

MODEL	motor type
CUST P/N	customer part no.
Ics	I <sub>0rms</sub> (standstill current)
Tcs	M <sub>0</sub> (standstill torque)
Vs	U <sub>n</sub> (DC bus link voltage)
Nrtd	n <sub>n</sub> (rated speed @ U <sub>n</sub> )
Prtd	P <sub>n</sub> (rated power)
Rm	R <sub>25</sub> (winding resistance @ 25°)
SERIAL	serial no.
AMBIENT	max. ambient temp.

Year of manufacturing is coded in the serial number: the first two digits of the serial number are the year of manufacturing, e.g. "07" means 2007.

15.3 Model number description

ENGLISH

AKM 6 2 P - A N C N DA 00

**Flange size**

1	40mm
2	58mm
3	70mm
4	84mm
5	108mm
6	138mm
7	188mm
8	260mm

**Rotor length**

1
2
3
4
5

**Winding type**

A .. Z
S special

**Flange**

A	IEC with accuracy N
B	NEMA
C	alternative IEC standard
D	other standard
G	alternative IEC standard
H	alternative IEC standard
M,T	reinforced bearing AKM8
R	IEC with accuracy R
S	special

**Shaft**

C	keyway
K	open keyway
N	smooth shaft
S	special

**Customization**

00	standard
01	with shaft seal
0W	Washdown
0F	Washdown Food
xx	special

**Feedback**

1-	Comcoder with 1024 PPR
2-	Comcoder with 2048 PPR
AA	Acuro(Biss) Single Turn
AB	Acuro(Biss) Multi Turn
C-	Smart Feedback Device
DA	ECN1x13 (not RoHS conf.)
DB	EQN1x25 (not RoHS conf.)
LA	ECI 1118/1319 Single Turn
LB	EQI 1130/ 1331 Multi Turn
GA	HIPERFACE Single Turn
GB	HIPERFACE Multi Turn
R-	Resolver
S-	special

**Brake**

2	24V holding brake
N	w/o brake
S	special

**Connectors**

B	angular connectors rotatable (AKM2)
C	0.5m shielded cable with IP65 connector (AKM1/2), angular connectors rotatable (AKM3..7)
D	single angular connector, rotatable (AKM2/3/4 with SFD, w/o brake)
G	straight connector (AKM2..7)
H	IP65 power connector size 1.5 for AKM74Q& AKM82 only
M	0.5m shielded cable with IP20 connectors (In < 6A)
P	0.5m shielded cable with single IP20 connector (In < 6A and SFD)
T	Terminal box for power and feedback connector size 1.0 (AKM8)
S	special



## 16 Technical Description

### 16.1 General technical data

<b>Ambient temperature (at rated values)</b>	5...+40°C for site altitude up to 1000m amsl It is vital to consult our applications department for ambient temperatures above 40°C and encapsulated mounting of the motors.
<b>Permissible humidity (at rated values)</b>	95% rel. humidity, no condensation
<b>Power derating (currents and torques)</b>	1% / K in range 40°C...50°C up to 1000m amsl for site altitude above 1000m amsl and 40°C 6% up to 2000m amsl 17% up to 3000m amsl 30% up to 4000m amsl 55% up to 5000m amsl No derating for site altitudes above 1000m amsl with temperature reduction of 10K / 1000m
<b>Ball-bearing life</b>	≥ 20.000 operating hours

#### NOTE

Technical data for every motor type can be found in chapter "Technical Data" from p. 74.

### 16.2 Standard features

#### 16.2.1 Style

The basic style for the AKM motors is style IM B5 according to EN 60034-7.

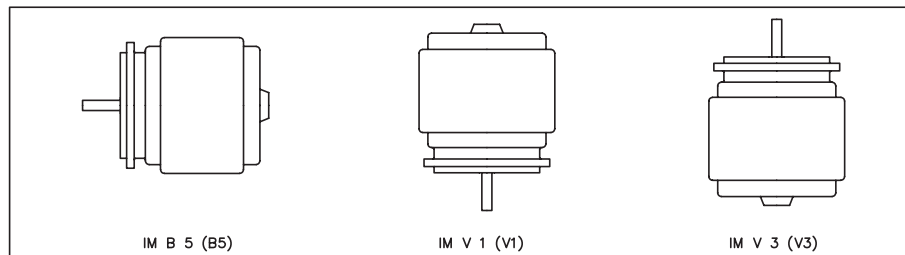

#### 16.2.2 Flange

Flange dimensions to IEC standard, fit j6 (AKM1: h7), accuracy according to DIN 42955.  
Tolerance class: **N**, optional R for IEC flange

#### 16.2.3 Protection class

Standard Version AKM1-4 with connector option M or P with or without sealing ring	IP20
Standard Version AKM1 with connector options C without sealing ring	IP40
Standard Version AKM2-AKM8 with connector options B, C, D, G, H, T without sealing ring	IP54
Standard Version AKM1-AKM8 with connector options B, C, D, G, H, T with sealing ring	IP65

#### 16.2.4 Insulation material class

The motors come up to insulation material class F according to IEC 60085 (UL 1446 class F).

#### 16.2.5 Surface

The motors are coated with polyester powder coating in matt black. This finish is not resistant against solvents (e.g. trichlorethylene, nitro-thinners, or similar).

**16.2.6 Shaft end, A-side**

Power transmission is made through the cylindrical shaft end A, fit k6 (AKM1: h7) to EN 50347, with a locking thread but **without a fitted-keyway**.  
Bearing life is calculated with 20.000 operating hours.

**Radial force**

If the motors drive via pinions or toothed belts, then high radial forces will occur. The permissible values at the end of the shaft may be read from the diagrams in chapter "Drawings" from p.87. The maximum values at rated speed you will find at the technical data. Power take-off from the middle of the free end of the shaft allows a 10% increase in  $F_R$ .

**Axial force**

When assembling pinions or wheels to the axis and use of e.g. angular gearheads axial forces arise. The maximum values at rated speed you will find at the technical data.

**Coupling**

Double-coned collets have proved to be ideal zero-backlash coupling devices, combined, if required, with metal bellows couplings.

**16.2.7 Protective device**

The standard version of each motor is fitted with an electrically isolated PTC (rated temperature  $155^{\circ}\text{C} \pm 5\%$ ). The PTC does **not** provide any protection against short, heavy overloading. Provided that our preassembled resolver cable is used, the PTC is integrated into the monitoring system of the digital servo amplifiers.

**16.2.8 Vibration class**

The motors are made to vibration class A according to EN 60034-14. For a speed range of 600-3600 rpm and a shaft centre between 56-132mm, this means that the actual value of the permitted vibration severity is 1.6mm/s.

Velocity [rpm]	max. rel. Vibration Displacement[ $\mu\text{m}$ ]	max. Run-out [ $\mu\text{m}$ ]
$\leq 1800$	90	23
$> 1800$	65	16

**16.2.9 Holding brake**

The AKM2-AKM8 motors are optionally available with a holding brake.  
A spring applied brake (24V DC) is integrated into the motors. When this brake is de-energized it blocks the rotor.

**⚠ WARNING** Personal safety in case of hanging loads (vertical axes) can be ensured only by using an additional, external, mechanical brake.  
If the brake is released then the rotor can be moved without a remanent torque.

**⚠ CAUTION** The holding brakes are designed as standstill brakes and are not suited for repeated operational braking. In the case of frequent, operational braking, premature wear and failure of the holding brake is to be expected.

The motor length increases when a holding brake is mounted.

The holding brake can be controlled directly by the servo amplifier (no personal safety !), the winding is suppressed in the servo amplifier — additional circuitry is not required (see instructions manual of the servo amplifier).

If the holding brake is not controlled directly by the servo amplifier, an additional wiring (e.g. varistor) is required. Consult our support department.

## 17 Mechanical Installation

### NOTE

Dimension drawings can be found in chapter "Dimension Drawings" from p.87.

### 17.1 Important Notes

#### CAUTION

Only qualified staff with knowledge of mechanical engineering are permitted to assemble the motor.

- Protect the motor from unacceptable stresses. Take care, especially during transport and handling, that components are not bent and that insulation clearances are not altered.
- The site must be free of conductive and aggressive material. For V3-mounting (shaft end upwards), make sure that no liquids can enter the bearings. If an encapsulated assembly is required, please consult our applications department beforehand.
- Ensure an unhindered ventilation of the motors and observe the permissible ambient and flange temperatures. For ambient temperatures above 40°C please consult our applications department beforehand.
- Servomotors are precision equipment. The flange and shaft are especially vulnerable during storage and assembly — so avoid brute force. Precision requires delicacy. It is important to use the locking thread which is provided to tighten up couplings, gear wheels or pulley wheels and warm up the drive components, where possible. Blows or the use of force will lead to damage to the bearings and the shaft.

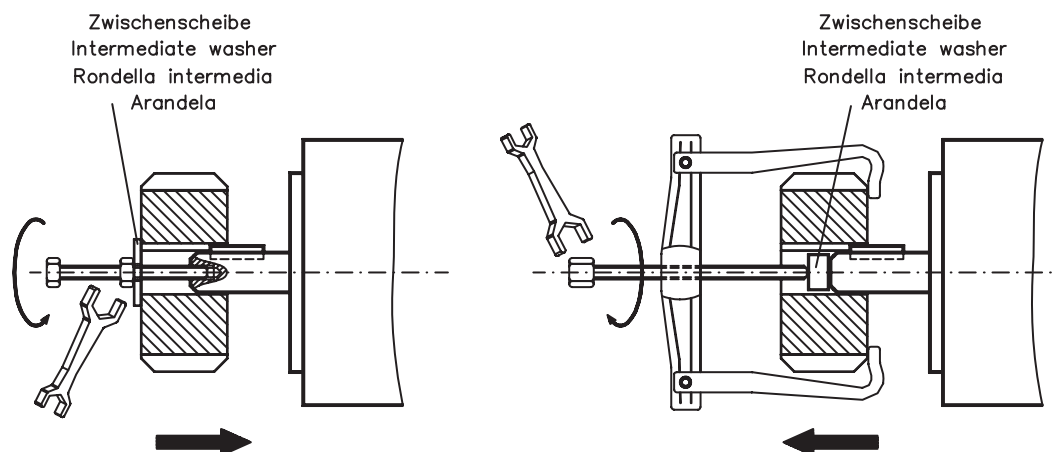

- Wherever possible, use only backlash-free, frictionally-locking collets or couplings. Ensure correct alignment of the couplings. A displacement will cause unacceptable vibration and the destruction of the bearings and the coupling.
- For toothed belts, it is vital to observe the permissible radial forces. An excessive radial load on the shaft will significantly shorten the life of the motor.
- Avoid axial loads on the motor shaft, as far as possible. Axial loading significantly shortens the life of the motor.
- In all cases, do not create a mechanically constrained motor shaft mounting by using a rigid coupling with additional external bearings (e.g. in a gearbox).
- Take note of the no. of motor poles and the no. of resolver poles, and ensure that the correct setting is made in the servo amplifier which is used. An incorrect setting can lead to the destruction of the motor, especially with small motors.
- Check the compliance to the permitted radial and axial forces  $F_R$  and  $F_A$ . When you use a toothed belt drive, the **minimal** permitted diameter of the pinion e.g. follows from the equation:  $d_{\min} \geq \frac{M_0}{F_R} \times 2$ .

## 18 Electrical Installation

**NOTE**

Wiring diagrams can be found in chapter "Wiring Diagrams" from p. 87. Pinout of the servo amplifier's end can be found in the instructions manual of the servo amplifier.

### 18.1 Safety notes

**▲ WARNING** Only staff qualified and trained in electrical engineering are allowed to wire up the motor.

Always make sure that the motors are de-energized during assembly and wiring, i.e. No voltage may be switched on for any piece of equipment which is to be connected. Ensure that the switch cabinet remains turned off (barrier, warning signs etc.). The individual voltages will only be turned on again during setup.

Never undo the electrical connections to the motor while it is energised. A dangerous voltage, resulting from residual charge, can be still present on the capacitors several minutes after switch-off of the mains supply. Measure the DC-link voltage and wait until it has fallen below 40V. Even when the motor is not rotating, control and power leads may be live.

**NOTE**

The ground symbol , which you will find in the wiring diagrams, indicates that you must provide an electrical connection, with as large a surface area as possible, between the unit indicated and the mounting plate in the switch cabinet. This connection is to suppress HF interference and must not be confused with the PE (protective earth) symbol (protective measure to EN 60204).

To wire up the motor, use the wiring diagrams in the Installation and Setup Instructions of the servo amplifier which is used.

### 18.2 Guide for electrical installation

- Check that the servo amplifier and motor match each other. Compare the rated voltage and rated current of the unit. Carry out the wiring according to the wiring diagram in the instructions manual of the servo amplifier. The connections to the motor are shown in chapter "Wiring Diagrams" from p.87.
- Ensure that there is proper earthing of the servo amplifier and the motor. Use correct earthing and EMC-shielding according to the instructions manual of the servo amplifier which is used. Earth the mounting plate and motor casing.
- Route the power and control cables as separately as possible from one another (separation > 20 cm). This will improve the immunity of the system to electromagnetic interference. If a motor power cable is used which includes integral brake control leads, then these brake control leads must be shielded. The shielding must be connected at both ends (see instructions manual of the servo amplifier).
- Cabling:
  - Route power cables as separately as possible from control cables
  - Connect up the resolver or encoder.
  - Connect the motor cables, install motor chokes close to the servo amplifier
  - Connect shields to shielding terminals or EMC connectors at both ends
  - Connect the holding brake, if used
  - Connect shielding at both ends.
- Install all cables carrying a heavy current with an adequate cross-section, as per EN 60204. The recommended cross-section can be found in the Technical data.

**NOTE**

In case of long motor cables (>25m) and dependent on the type of the used servo amplifier a motor choke (3YL or 3YLN) must be switched into the motor cable (see instructions manual of the servo amplifier and accessory manual).

- Connect up all shielding via a wide surface-area contact (low impedance) and metallized connector housings or EMC-cable glands.

### 18.3 Connection of the motors with preassembled cables

**NOTE**

Wiring diagrams can be found in chapter "Wiring Diagrams" from p.87.

- Carry out the wiring in accordance with the valid standards and regulations.
- Only use our preassembled shielded cables for the resolver and power connections.
- Connect up the shielding according to the wiring diagrams in the instructions manual for the servo amplifier.
- Incorrectly installed shielding inevitably cables to EMC interference.
- The maximum cable length is defined in the instructions manual of the used servo amplifier.

Requirements to cable material:

**Capacity**

Motor cable	less than 150 pF/m
Resolver cable	less than 120 pF/m

**NOTE**

For a detailed description of preassembled cables, please refer to the accessories manual.

## 19 Setup

### 19.1 Important notes

**⚠ WARNING**

- Only specialist personnel with extensive knowledge in the areas of electrical engineering / drive technology are allowed to commission the drive unit of servo amplifier and motor.
- Check that all live connection points (terminal boxes) are safe against accidental contact. Deadly voltages can occur, up to 900V.
- Never undo the electrical connections to the motor when it is live. The residual charge in the capacitors of the servo amplifier can produce dangerous voltages several minutes after the mains supply has been switched off.
- The surface temperature of the motor can exceed 100°C in operation. Check (measure) the temperature of the motor. Wait until the motor has cooled down below 40°C before touching it.
- Make sure that, even if the drive starts to move unintentionally, no danger can result for personnel or machinery.

### 19.2 Guide for setup

The procedure for setup is described as an example. A different method may be appropriate or necessary, depending on the application of the equipment.

- Check the assembly and orientation of the motor.
- Check the drive components (clutch, gear unit, belt pulley) for the correct seating and setting (observe the permissible radial and axial forces).
- Check the wiring and connections to the motor and the servo amplifier. Check that the earthing is correct.
- Test the function of the holding brake, if used. (apply 24V, the brake must be released).
- Check whether the rotor of the motor revolves freely (release the brake, if necessary). Listen out for grinding noises.
- Check that all the required measures against accidental contact with live and moving parts have been carried out.
- Carry out any further tests which are specifically required for your system.
- Now commission the drive according to the setup instructions for the servo amplifier.
- In multi-axis systems, individually commission each drive unit (servo amplifier and motor).

## 19.3 Trouble Shooting

The following table is to be seen as a “First Aid” box. There can be a large number of different reasons for a fault, depending on the particular conditions in your system. The fault causes described below are mostly those which directly influence the motor. Peculiarities which show up in the control loop behaviour can usually be traced back to an error in the parameterization of the servo amplifier. The documentation for the servo amplifier and the setup software provides information on these matters.

For multi-axis systems there may be further hidden reasons for faults.

Our customer support can give you further help with your problems.

Fault	Possible cause	Measures to remove the cause of the fault
<b>Motor doesn't rotate</b>	<ul style="list-style-type: none"> <li>— Servo-amplifier not enabled</li> <li>— Break in setpoint lead</li> <li>— Motor phases in wrong sequence</li> <li>— Brake not released</li> <li>— Drive is mechanically blocked</li> </ul>	<ul style="list-style-type: none"> <li>— Supply ENABLE signal</li> <li>— Check setpoint lead</li> <li>— Correct the phase sequence</li> <li>— Check brake controls</li> <li>— Check mechanism</li> </ul>
<b>Motor runs away</b>	<ul style="list-style-type: none"> <li>— Motor phases in wrong sequence</li> </ul>	<ul style="list-style-type: none"> <li>— Correct the phase sequence</li> </ul>
<b>Motor oscillates</b>	<ul style="list-style-type: none"> <li>— Break in the shielding of the resolver cable</li> <li>— amplifier gain to high</li> </ul>	<ul style="list-style-type: none"> <li>— Replace resolver cable</li> <li>— use motor default values</li> </ul>
<b>Error message: brake</b>	<ul style="list-style-type: none"> <li>— Short-circuit in the supply voltage lead to the motor holding brake</li> <li>— Faulty motor holding brake</li> </ul>	<ul style="list-style-type: none"> <li>— Remove the short-circuit</li> <li>— Replace motor</li> </ul>
<b>Error message: output stage fault</b>	<ul style="list-style-type: none"> <li>— Motor cable has short-circuit or earth short</li> <li>— Motor has short-circuit or earth short</li> </ul>	<ul style="list-style-type: none"> <li>— Replace cable</li> <li>— Replace motor</li> </ul>
<b>Error message: resolver</b>	<ul style="list-style-type: none"> <li>— Resolver connector is not properly plugged in</li> <li>— Break in resolver cable, cable crushed or similar</li> </ul>	<ul style="list-style-type: none"> <li>— Check connector</li> <li>— Check cables</li> </ul>
<b>Error message: motor temperature</b>	<ul style="list-style-type: none"> <li>— Motor thermostat has switched</li> <li>— Loose resolver connector or break in resolver cable</li> </ul>	<ul style="list-style-type: none"> <li>— Wait until the motor has cooled down. Then investigate why the motor becomes so hot.</li> <li>— Check connector, replace resolver cable if necessary</li> </ul>
<b>Brake does not grip</b>	<ul style="list-style-type: none"> <li>— Required holding torque too high</li> <li>— Brake faulty</li> <li>— Motor shaft axially overloaded</li> </ul>	<ul style="list-style-type: none"> <li>— Check the dimensioning</li> <li>— Replace motor</li> <li>— Check the axial load, reduce it. Replace motor, since the bearings have been damaged</li> </ul>

20 Technical Data

**NOTE** Technical data for every motor type can be found in chapter "Technical Data" from p. 74.

All data valid for 40°C environmental temperature and 100K overtemperature of the winding. The data can have a tolerance of +/- 10%.

20.1 Definition of Terms

**Standstill torque  $M_0$  [Nm]**

The standstill torque can be maintained indefinitely at a speed  $0 < n < 100$  rpm and rated ambient conditions.

**Rated torque  $M_n$  [Nm]**

The rated torque is produced when the motor is drawing the rated current at the rated speed. The rated torque can be produced indefinitely at the rated speed in continuous operation (S1).

**Standstill current  $I_{0rms}$  [A]**

The standstill current is the effective sinusoidal current which the motor draws at  $0 < n < 100$  rpm to produce the standstill torque.

**Peak current (pulse current)  $I_{0max}$  [A]**

The peak current (effective sinusoidal value) is approximately equivalent to 5 times the rated current. The actual value is determined by the peak current of the servo amplifier which is used.

**Torque constant  $K_{Trms}$  [Nm/A]**

The torque constant defines how much torque in Nm is produced by the motor with 1A r.m.s. current. The relationship is  $M = I \times K_T$  (up to  $I = 2 \times I_0$ )

**Voltage constant  $K_{Erms}$  [mV/min<sup>-1</sup>]**

The voltage constant defines the induced motor EMF, as an effective sinusoidal value between two terminals, per 1000 rpm

**Rotor moment of inertia  $J$  [kgcm<sup>2</sup>]**

The constant  $J$  is a measure of the acceleration capability of the motor. For instance, at  $I_0$  the acceleration time  $t_b$  from 0 to 3000 rpm is given as:

$$t_b [s] = \frac{3000 \times 2\pi}{M_0 \times 60s} \times \frac{m^2}{10^4 \times cm^2} \times J \quad \text{with } M_0 \text{ in Nm and } J \text{ in kgcm}^2$$

**Thermal time constant  $t_{th}$  [min]**

The constant  $t_{th}$  defines the time for the cold motor, under a load of  $I_0$ , to heat up to an overtemperature of  $0.63 \times 105$  Kelvin. This temperature rise happens in a much shorter time when the motor is loaded with the rated current.

**Release delay time  $t_{BRH}$  [ms] / Application delay time  $t_{BRL}$  [ms] of the brake**

These constants define the response times of the holding brake when operated with the rated voltage from the servo amplifier.

**$U_N$**

Rated mains voltage

**$U_n$**

DC-Bus link voltage.  $U_n = \sqrt{2} * U_N$



## 21 Indicazioni generali

### 21.1 Questo manuale

Questo manuale descrive i servomotori sincroni della serie AKM (versione standard).

Se i motori vengono utilizzati in un sistema di azionamento insieme ai servoamplificatori Kollmorgen. Attenersi pertanto alla documentazione dei prodotti composta da:

- manuale di istruzioni del servoamplificatore
- istruzioni per l'installazione/la messa in funzione di una scheda di espansione
- eventualmente presente
- aiuto in linea del software operativo del servoamplificatore
- manuale degli accessori
- descrizione tecnica dei motori serie AKM

Più informazioni di base possono essere trovate nel nostro "Prodotto WIKI", disponibile a [www.wiki-kollmorgen.eu](http://www.wiki-kollmorgen.eu).





### 21.2 Gruppo di obiettivo

Questo manuale è rivolto a personale con le seguenti qualifiche:

- Trasporto: solo a cura di personale con nozioni di movimentazione componenti sensibili alle cariche elettrostatiche.
- Installazione mecc.: solo da parte di meccanici specializzati
- Installazione elett.: solo a cura di elettricisti qualificati.
- Configurazione: solo a cura di personale qualificato con nozioni approfondite in materia di elettrotecnica e tecnologia di azionamento.
- Il personale tecnico deve conoscere e osservare le seguenti norme e direttive:  
I.C. 60364 o I.C. 60664  
disposizioni antinfortunistiche nazionali

**⚠ AVVERTENZA** L'operatore deve accertarsi che le istruzioni di sicurezza in questo manuale siano seguite. L'operatore deve accertarsi che tutti i personali responsabili del funzionamento con motore abbiano letto e capito il manuale del prodotto.

### 21.3 Simboli utilizzati

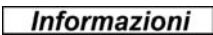
Symbolo	Significato
 <b>PERICOLO</b>	Segnala una situazione di pericolo che, se non evitata, comporta la morte o lesioni gravi e permanenti.
 <b>AVVERTENZA</b>	Segnala una situazione di pericolo che, se non evitata, può comportare la morte o lesioni gravi e permanenti.
 <b>ATTENZIONE</b>	Segnala una situazione di pericolo che, se non evitata, può comportare infortuni leggeri.
 <b>AVVISO</b>	Segnala una situazione di pericolo che, se non evitata, può comportare danni materiali.
 <b>Informazioni</b>	Questo non è un simbolo di sicurezza, ma serve a segnalare informazioni importanti.

### 21.4 Abbreviazioni utilizzati

Veda il capitolo 30.1 "Definizioni".

## 22 Sicurezza

### 22.1 Indicazioni di sicurezza

#### ⚠️ AVVERTENZA

- Il produttore è tenuto a realizzare un'analisi dei rischi per il macchinario e ad adottare le misure necessarie, affinché eventuali movimenti impreveduti non causino danni a persone o a cose.
- Assicurare la regolare messa a terra della carcassa del motore con la bandella PE all'interno dell'armadio di distribuzione come potenziale di riferimento. Senza una messa a terra a bassa impedenza non viene garantita alcuna sicurezza alle persone.
- Non scollegare nessun connettore durante il funzionamento. Sussiste il pericolo di morte, di seri infortuni o danni materiali.
- I collegamenti di potenza possono condurre tensione anche a motore fermo. Non allentare mai i collegamenti elettrici dei motori sotto tensione. In casi sfavorevoli possono venire a crearsi archi voltaici con conseguenti danni a carico di persone e cose.
- Dopo aver scollegato i servoamplificatori dalle tensioni di alimentazione attendere parecchi minuti prima di toccare i componenti sotto tensione (ad esempio contatti, perni filettati) o di allentare collegamenti. I condensatori nel servoamplificatore conducono tensioni pericolose parecchi minuti dopo la disinserzione delle tensioni di alimentazione. Per sicurezza, misurare la tensione nel circuito intermedio e attendere fino a quando il valore è sceso al di sotto dei 40V.
-  Durante il funzionamento i motori possono presentare superfici calde a seconda del loro grado di protezione. La temperatura superficiale può varcare i 100°C. Misurare la temperatura e attendere che il motore abbia raggiunto i 40°C prima di toccarlo.
- Se il motore ruota liberamente rimuovere/fissare l'eventuale chiavetta dell'albero per evitarne l'espulsione con conseguente pericolo di lesioni.
- I freni di stazionamento integrati non garantiscono la sicurezza del personale! In presenza di carichi sospesi (assi verticali) è necessario utilizzare un freno meccanico esterno aggiuntivo per garantire la sicurezza del personale.

#### ⚠️ ATTENZIONE

- I lavori di trasporto, montaggio, messa in funzione e manutenzione si possono affidare esclusivamente a personale tecnico qualificato, che abbia familiarità con il trasporto, l'installazione, il montaggio, la messa in funzione e il funzionamento dei motori e che disponga di opportune qualifiche per lo svolgimento di tali attività. Il personale tecnico deve conoscere e osservare le seguenti norme e direttive:  
IEC 60364 o IEC 60664  
disposizioni antinfortunistiche nazionali
- Prima di procedere al montaggio e alla messa in funzione leggere la presente documentazione. L'errata manipolazione del motore può comportare danni a persone o a cose. Osservare assolutamente i dati tecnici e le indicazioni sulle condizioni di collegamento (targhetta di omologazione e documentazione).

**22.2****Uso conforme**

- I servomotori sincroni della serie AKM sono stati concepiti in modo particolare come azionamento per dispositivi di movimentazione, macchine tessili, macchine utensili, confezionatrici e simili con elevati requisiti in termini di dinamica.
- Azionare i motori **solo** nel rispetto delle condizioni stabilite nella presente documentazione.
- I motori della serie AKM sono **esclusivamente** destinati ad essere comandati da servoamplificatori digitali con regolazione della velocità e/o della coppia.
- I motori vengono montati come componenti su impianti o macchine elettrici e possono essere messi in funzione solo come componenti integrati dell'impianto.
- Si richiedono l'analisi e il monitoraggio del termocontatto di protezione montato negli avvolgimenti del motore.
- I freni di stazionamento sono predisposti come freni di stazionamento e non sono adatti per frenare in modo continuo durante il funzionamento.
- Garantiamo la conformità del servosistema alle norme menzionate nella EC Declaration of Conformity a pagina 44 solo se vengono utilizzati componenti originali (servoamplificatori, motore, cavi, e così via).

**22.3****Uso conforme vietato**

- È vietato l'uso del motor nei seguenti ambienti:
  - aree a rischio di esplosione
  - ambienti caratterizzati dalla presenza di acidi, soluzioni alcaline, oli, vapori, polveri corrosivi e/o conduttivi
  - direttamente su reti elettriche
- L'uso conforme del motore è vietato quando la macchina cui è destinato
  - non è conforme alle disposizioni della Direttiva Macchine
  - non soddisfa le disposizioni della Direttiva sulla Compatibilità Elettromagnetica
  - non soddisfa le disposizioni della Direttiva Bassa Tensione
- Per garantire la sicurezza del personale non vanno utilizzati i freni di stazionamento senza ulteriori dispositivi.

**23 Norme validi****23.1 EC Declaration of Conformity**

We, the company

Kollmorgen Europe GmbH  
Pempelfurtstraße 1  
D-40880 Ratingen

hereby in sole responsibility declare the conformity of the product series

**Motor series AKM**  
**(Types AKM1, AKM2, AKM3, AKM4, AKM5, AKM6, AKM7, AKM8)**

with the following standards:

- EC Directive 2004/108/EC  
Electromagnetic compatibility  
Used standard EN61800-3:07/2005
- EC Directive 2006/95/EC  
Electrical devices for use in special voltage limits  
Used standard EN61800-5-1:04/2008

Year of EC-Declaration      2003  
Issued by:                      Product Manager Motors Europe  
   Jörg Peters  
   Ratingen, 01.12.2010

Legally valid signature



This Declaration does not contain any assurance of properties in the meaning of product liability.  
The notes on safety and protection in the operating instructions must always be observed.  
The above-mentioned company has the following technical documentation for examination:

- Proper operating instructions
- Diagrams (for EU authority only)
- Test certificates (for EU authority only)
- Other technical documentation (for EU authority only)

## 24 Maneggiamento

### 24.1 Trasporto

- Temperatura di trasporto da -25 a +70°C, variazione max. 20K/ora  
umidità atmosferica durante il trasporto:umidità relativa del 5% - 95% senza condensa
- Solo da parte di personale qualificato in imballaggio originale riciclabile del produttore
- Evitare urti violenti, in particolare sull'estremità dell'albero
- In caso di imballaggio danneggiato, verificare che il motore non presenti danni visibili. Informarne il trasportatore ed eventualmente il produttore.

Gli anelli di sollevamento vengono utilizzati per trasportare i motori AKM8 in sicurezza. Rispettare le istruzioni di trasporto allegate alla confezione del motore. Sugeriamo l'attrezzo ZPZM 120/292 di trasporto per lo spostamento dei motori AKM8. L'unità ZPMZ 120/292 della sospensione consiste di un fascio, sospeso al gancio della gru e due doppio-fanno funzionare le bretelle chain.

#### **▲ PERICOLO**

**Quando si esegue la procedura di sollevamento non sostare mai sotto il carico.**

- Le viti di montaggio degli anelli di sollevamento devono essere serrate completamente.
- Gli anelli di sollevamento devono essere posizionati sulla superficie di supporto in maniera uniforme e in piano.
- Prima dell'utilizzo, verificare che gli anelli di sollevamento siano correttamente montati e privi di danni evidenti (corrosione, deformazione).
- Se si individuano delle deformazioni gli anelli di sollevamento non devono essere utilizzati.

B1/ 4 x LIFTING BOLT PLUS LIFTING BEAM

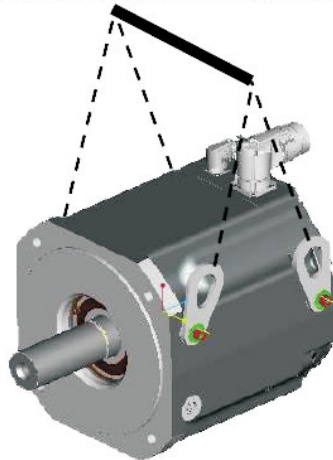

B2/ 2 x LIFTING BOLT PLUS LIFTING BEAM

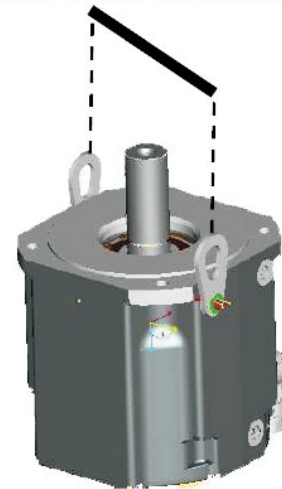

B3/ 2 x LIFTING BOLT PLUS LIFTING BEAM



## 24.2

**Imballaggio**

- Imballaggio del cartone con rivestimento di Instapak®.
- Potete restituire la parte di plastica al fornitore (veda "Smaltimento")

Tipo	Imballaggio	Altezza d'impilaggio max.	Tipo	Imballaggio	Altezza d'impilaggio max.
AKM1	Cartone	10	AKM5	Cartone	5
AKM2	Cartone	10	AKM6	Cartone	1
AKM3	Cartone	6	AKM7	Cartone	1
AKM4	Cartone	6	AKM8	Paletta	1

## 24.3

**Stoccaggio**

- Temperatura di stoccaggio da 25 a +55°C, variazione max. 20K/ora
- Umidità atmosferica um. rel. del 5% - 95% senza condensa
- Solo in imballaggio originale riciclabile del produttore
- Per l'altezza d'impilaggio max. ved. tabella imballaggio
- Durata a magazzino illimitata

## 24.4

**Manutenzione / Puliza**

- Solo da parte di personale qualificato
- Dopo 20.000 ore d'esercizio alle condizioni nominali occorre sostituire i cuscinetti a sfere.
- Controllare il motore ogni 2500 ore d'esercizio o una volta l'anno per verificare la rumorosità dei cuscinetti a sfere. Se si riscontrano rumori evitare di utilizzare il motore - i cuscinetti devono essere sostituiti.
- L'apertura dei motori comporta l'annullamento della garanzia.
- Pulizia con isopropanolo o similari, **non immergere o nebulizzare**

## 24.5

**Riparazioni**

Il motore può essere riparato unicamente dal fabbricante; l'apertura dell'apparecchio annulla automaticamente la garanzia. Mettere l'apparecchio fuori servizio e inviarlo al fabbricante:

Kollmorgen Europe GmbH  
Pempelfurtstraße 1  
D-40880 Ratingen

## 24.6

**Smaltimento**

Nell'accordo al WEEE-2002/96/EG-Guidelines prendiamo i vecchi dispositivi ed accessori indietro per eliminazione professionale, se i costi del trasporto sono y rilevato il mittente. Trasmetta i dispositivi a:

Kollmorgen Europe GmbH  
Pempelfurtstraße 1  
D-40880 Ratingen

## 25 Identificazione del prodotto

### 25.1 Dotazione

Imballaggio del cartone con rivestimento di Instapak®.

- Motore della serie AKM
- Manuale Prodotto (multi linguale)

### 25.2 Targhetta di omologazione

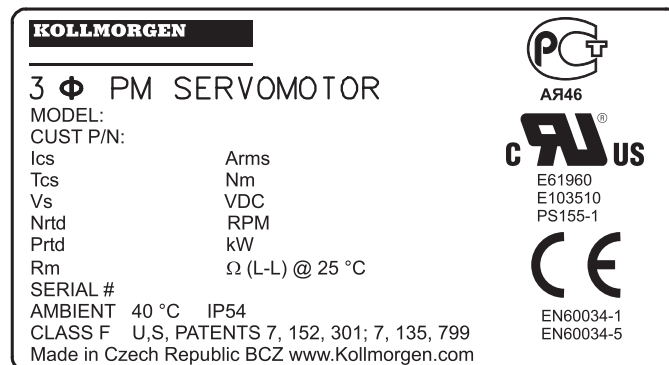

#### Legend

MODEL	tipo del motore
CUST P/N	numero del pezzo del cliente
Ics	$I_{0rms}$ (corrente continuativa allo stallo)
Tcs	$M_0$ (coppia continuativa allo stallo)
Vs	$U_n$ (tensione di circuito intermedio)
Nrtd	nn (velocità nominale @ $U_n$ )
Prtid	$P_n$ (potenza nominale)
Rm	R25 (resistenza avvolgimento @ 25°)
SERIAL	numero di serie
AMBIENT	temperatura ambiente max.

L'anno di fabbricazione è codificato nel numero di serie: le prime due cifre del numero di serie sono l'anno di fabbricazione, per esempio "07" significa 2007.

25.3

Codici dei modelli

**AKM 6 2 P - A N C N DA 00**

**Misura flangia**  
 1 40mm  
 2 58mm  
 3 70mm  
 4 84mm  
 5 108mm  
 6 138mm  
 7 188mm  
 8 260mm

**Lunghezza rotore**  
 1  
 2  
 3  
 4  
 5

**Tipo di bobina**  
 A .. Z  
 S speciale

**Flangia**  
 A IEC precisione N  
 B NEMA  
 C Norma IEC alternativa  
 D Altra norma  
 G Norma IEC alternativa  
 H Norma IEC alternativa  
 M,T cuscinetto rinforzato AKM8  
 R IEC precisione R  
 S speciale

**Arbero**  
 C con chiavetta  
 K con chiavetta aperta  
 N Arbero liscio  
 S speciale

**Versione**  
 00 standard  
 01 Guarnizione ad anello  
 OW Washdown  
 OF Washdown Food  
 xx speciale

**Retroazione**  
 1- Comcoder con 1024 Incr/giro  
 2- Comcoder con 2048 Incr/giro  
 AA Acuro(Biss) Single Turn  
 AB Acuro(Biss) Multi Turn  
 C- Smart Feedback Device  
 DA ECN1x13 (not RoHS conf.)  
 DB EQN1x25 (not RoHS conf.)  
 LA ECI 1118/1319 Single Turn  
 LB EQI 1130/ 1331 Multi Turn  
 GA HIPERFACE Single Turn  
 GB HIPERFACE Multi Turn  
 R- Resolver  
 S- speciale

**Freno**  
 2 Freno 24V  
 N senza freno  
 S speciale

**Connettori**  
 B connettori piegati girevoli (AKM2)  
 C 0.5m cavo schermato con connettore IP65 (AKM1/2), connettori piegati girevoli (AKM3..7)  
 D connettore singolo piegato, girevole (AKM2/3/4 con SFD, senza freno)  
 G connettore diritto (AKM2..7)  
 H connettore elettrico IP65 misura 1,5 solo per AKM74Q& AKM82  
 M 0.5m cavo schermato con connettore IP20 (In < 6A)  
 P 0.5m cavo schermato con connettore singolo IP20 (In < 6A e SFD)  
 T Scatola morsettiera per alimentazione e connettore di retroazione misura 1,0 (AKM8)  
 S speciale

ITALIANO



## 26 Descrizione tecnici

### 26.1 Dati tecnici generali

<b>Temperatura ambiente</b> (ai dati nominali)	da 5 a +40°C ad un'altitudine d'installazione fino a 1000 m sopra il livello del mare In caso di temperature ambiente superiori ai 40°C e di motori in esecuzione chiusa contattare il nostro settore applicazioni.								
<b>Umidità atmosferica ammessa</b> (ai dati nominali)	Umidità relativa dell'95%, non soggetta a condensa								
<b>Riduzione delle prestazioni</b> (correnti e coppie)	1%/K in un intervallo da 40°C a 50°C fino a 1000m sopra il livello del mare (LdM) Per altitudini d'installazione oltre i 1000 m sopra il LdM e e 40°C <table> <tr> <td>6%</td> <td>a 2000 m sopra il LdM</td> </tr> <tr> <td>17%</td> <td>a 3000 m sopra il LdM</td> </tr> <tr> <td>30%</td> <td>a 4000 m sopra il LdM</td> </tr> <tr> <td>55%</td> <td>a 5000 m sopra il LdM</td> </tr> </table> Nessuna riduzione delle prestazioni ad altitudini d'installazione oltre i 1000 m sopra il LdM e riduzione della temp. di 10K/1000m	6%	a 2000 m sopra il LdM	17%	a 3000 m sopra il LdM	30%	a 4000 m sopra il LdM	55%	a 5000 m sopra il LdM
6%	a 2000 m sopra il LdM								
17%	a 3000 m sopra il LdM								
30%	a 4000 m sopra il LdM								
55%	a 5000 m sopra il LdM								
<b>Durata dei cuscinetti a sfere</b>	≥ 20.000 ore d'esercizio								

#### Informazioni

Per i dati tecnici di ogni tipo di motore consultare il capitolo "Technical Data" da p. 74.

### 26.2 Allestimento standard

#### 26.2.1 Forma costruttiva

I modelli base dei servomotori sincroni AKM hanno forma costruttiva IM B5 secondo EN 60034-7.

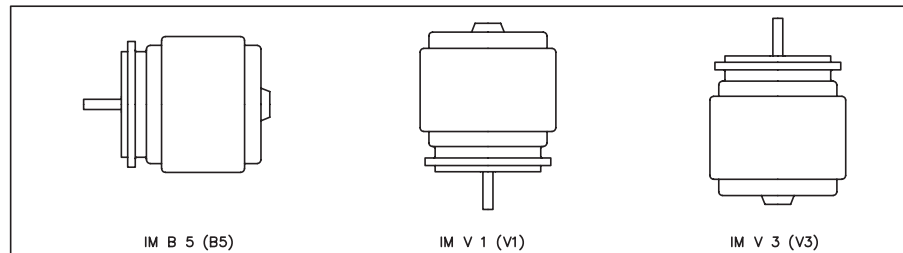

#### 26.2.2 Flangia

Dimensioni flangia conformi a norma IEC, accoppiamento j6 (AKM1: h7), precisione secondo DIN 42955, classe di tolleranza: **N**, optional R per flangia di IEC

#### 26.2.3 Grado di protezione

Versione standard AKM1-4 con connettore M or P con o sin anello di tenuta	IP20
Versione standard AKM1 con connettore C sin anello di tenuta	IP40
Versione standard AKM2-AKM8 con connettore B, C, D, G, H, T sin anello di tenuta	IP54
Versione standard AKM1-AKM8 con connettore B, C, D, G, H, T con anello di tenuta	IP65

#### 26.2.4 Classe di isolamento

I motori sono conformi alla classe isolante F secondo IEC 60085 (UL 1446 class F).

#### 26.2.5 Superficie

I motori sono ricoperti di rivestimento della polvere del poliestere nel nero opaco non resistente ai solventi (tricloroetilene, diluenti o altro).

### 26.2.6 Estremità di uscita albero

La trasmissione della forza ha luogo attraverso l'estremità cilindrica di uscita dell'albero, accoppiamento k6 (AKM1: h7) secondo EN 50347 con filettatura di serraggio ma **senza sede per chiavetta**. Per la durata dei cuscinetti sono state calcolate come base 20.000 ore d'esercizio.

#### Forza radiale

Se i motori si azionano mediante pignone o cinghie dentate vengono a determinarsi forze radiali elevate. I valori ammessi sull'estremità dell'albero, in funzione del numero di giri, sono indicati nei diagrammi nel cap. "Drawings" p.87. I valori massimi si trovano nei dati tecnici. In caso di applicazione della forza al centro dell'estremità libera dell'albero, il valore di  $F_R$  può essere maggiore del 10%.

#### Forza assiale

Mentre pignoni o rotelle di montaggio all'asse o nel caso di uso del sistema d'ingranaggi angolare delle forze assiali presenti. I valori massimi si trovano nei dati tecnici.

#### Accoppiamenti

Come elementi di accoppiamento idealmente privi di gioco si sono rivelate valide le Pinze a doppio cono eventualmente abbinata a accoppiamenti con attacchi metallici a soffietto.

### 26.2.7 Dispositivo di protezione

Nella versione standard ogni motore dispone di un PTC a potenziale zero. Il punto di commutazione è a  $155^{\circ}\text{C} \pm 5\%$ . Questo PTC **non** offre alcuna protezione nei confronti di sovraccarichi brevi molto elevati. Utilizzando il nostro cavo per resolver preconfezionato il PTC è integrato nel sistema di controllo dei servoamplificatori digitali.

### 26.2.8 Resistenza alle vibrazioni

I motori sono eseguiti con resistenza alle vibrazioni A secondo EN 60034-14. Per un campo di velocità compreso tra 600 e 3600 giri/m e un asse di altezza compresa tra 56 e 132 mm questo determina un'ampiezza di oscillazione ammessa di 1,6 mm/s come valore efficace.

Velocità [rpm]	max. rel. Spostamento Vibratorio [ $\mu\text{m}$ ]	max. Run-out [ $\mu\text{m}$ ]
$\leq 1800$	90	23
$> 1800$	65	16

### 26.2.9 Freno di stazionamento

I motori AKM2-AKM8 sono disponibili a scelta con freno di stazionamento integrato. Il freno di tipo a molla (24VDC) blocca il rotore quando non è applicata tensione.

**⚠AVVERTENZA** Per garantire la sicurezza del personale in presenza di carichi sospesi (assi verticali) è necessario utilizzare un freno meccanico esterno aggiuntivo.  
Se alimentato il freno non oppone alcuna coppia resistente alla rotazione del motore.

**⚠ATTENZIONE** I freni di stazionamento sono predisposti come freni di stazionamento e non sono adatti per frenare in modo continuo durante il funzionamento.  
In caso di frenature operative frequenti è prevedibile l'usura prematura del freno di stazionamento.

In presenza del freno di stazionamento integrato la lunghezza del motore aumenta.

I freni di stazionamento possono essere comandati direttamente dal servoamplificatore (non garantisce la sicurezza delle persone); il rilascio dell'avvolgimento del freno in questo caso avviene nel servoamplificatore - non è necessario alcun componente supplementare.

Se il freno di stazionamento non viene comandato direttamente dal servoamplificatore occorre il cablaggio di un componente supplementare (ad esempio un varistore). Contattare a questo proposito il nostro supporto tecnico.

## 27 Installazione meccanica

### Informazioni

Le illustrazioni di dimensione possono essere trovate nel capitolo "Dimension Drawings" p.87.

### 27.1 Indicazioni importanti

#### ATTENZIONE

Solo personale tecnico con esperienza di montaggio meccanico può montare il motore.

- Proteggere i motori da sollecitazioni non ammesse. In particolare, durante il trasporto e la movimentazione non piegare elementi costruttivi e/o modificare le distanze d'isolamento.
- Il luogo di installazione deve essere privo di materiali conduttivi e aggressivi. In caso di il montaggio V3 (estremità dell'albero rivolta verso l'alto) assicurarsi che nessun liquido si infiltri nei cuscinetti. In caso di montaggio in esecuzione chiusa consultare prima il nostro settore applicazioni.
- Assicurare la libera ventilazione dei motori e rispettare i valori ammessi per la temperatura ambiente e della flangia. In caso di temperature ambiente superiori ai 40°C consultare prima il nostro settore applicazioni.
- I servomotori sono apparecchi di precisione. In particolare flangia e albero possono trovarsi in una condizione critica durante lo stoccaggio ed il montaggio - evitare quindi di esercitare forza eccessiva: la precisione richiede delicatezza. Per fissare accoppiamenti, ruote dentate o pulegge utilizzare la filettatura di serraggio prevista per l'albero motore e, se possibile, riscaldare le prese di forza. Urti o l'esercizio di forza eccessiva possono danneggiare cuscinetti a sfere e albero.

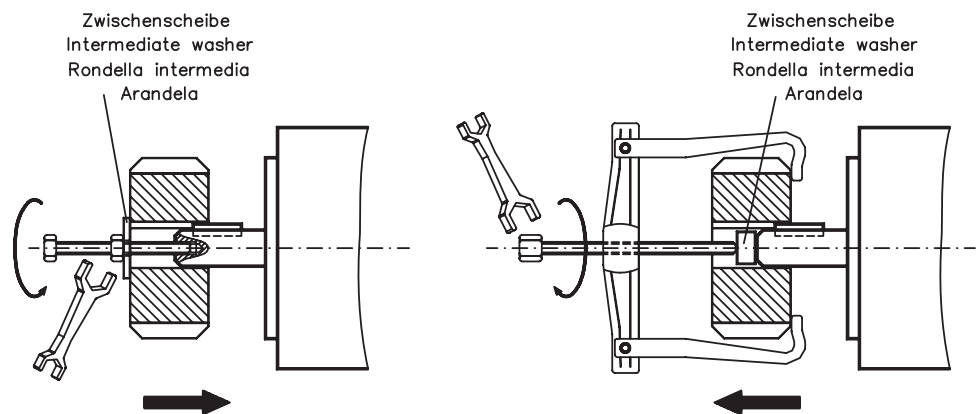

- Se possibile impiegare esclusivamente Pinze o accoppiamenti privi di gioco, con accoppiamento per attrito. Assicurarsi che l'accoppiamento sia allineato correttamente. Eventuali spostamenti possono causare vibrazioni non ammesse e possono determinare la rottura dei cuscinetti a sfere e dell'accoppiamento stesso.
- In caso d'impiego di cinghie dentate rispettare le forze radiali ammesse. Una sollecitazione radiale eccessiva dell'albero riduce notevolmente la durata del motore.
- Evitare il più possibile la sollecitazione assiale dell'albero motore. Una sollecitazione assiale riduce notevolmente la durata del motore.
- Evitare sempre di sovradimensionare meccanicamente il supporto dell'albero motore usando un accoppiamento rigido e un supporto supplementare esterno (ad esempio nella trasmissione).
- Rispettare il numero di poli del motore e del resolver e nei servoamplificatori utilizzati impostare il numero di poli in modo corretto. Una regolazione errata può comportare danni irreversibili, in particolare nei motori di piccole dimensioni.
- Verificare il rispetto delle sollecitazioni radiali e assiali ammesse  $F_R$  e  $F_A$ . Impiegando una trasmissione a cinghia dentata, il diametro **minimo** ammesso per il pignone viene ad esempio calcolato in base all'equazione:  $d_{\min} \geq \frac{M_0}{F_R} \times 2$ .

## 28 Installazione elettrica

**Informazioni** Gli schemi elettrici possono essere trovati nel capitolo "Wiring Diagrams" p.87. Pinout di servo amplificatore può essere trovato nella manuale d'istruzione di servo amplificatore.

### 28.1 Indicazioni di sicurezza

**AVVERTENZA** Solo personale tecnico con esperienza nei collegamenti elettrici può cablare il motore.

Montare e cablare i motori sempre in assenza di tensione, vale a dire senza inserire la tensione d'esercizio degli apparecchi da collegare. Assicurarsi che il quadro elettrico venga disinserito in modo sicuro (blocco, cartelli di avvertenza, e così via). Le singole tensioni verranno inserite solo con la messa in funzione.

Non allentare mai i collegamenti elettrici dei motori sotto tensione. Le cariche residue nei condensatori del servoamplificatore possono presentare valori pericolosi anche parecchi minuti dopo la disinserzione della tensione di rete. Misurare la tensione nel circuito intermedio e attendere fino a quando il valore è sceso al di sotto dei 40V. I collegamenti di comando e di potenza possono condurre tensione anche a motore fermo.

**Informazioni** Il simbolo messa a terra  che si trova in tutti gli schemi di collegamento indica che occorre provvedere ad un collegamento conduttivo il più ampio possibile tra l'apparecchio identificato e la piastra di montaggio nel quadro elettrico ad armadio. Tale collegamento deve consentire la dispersione di interferenze ad alta frequenza e non deve essere confuso con il simbolo di terra PE (misura di protezione secondo EN 60204). Osservare anche le note negli schemi di collegamento delle manuale di istruzioni del servoamplificatore utilizzato.

### 28.2 Guida ad installazione elettrica

- Verificare l'abbinamento tra servoamplificatori e motore. Confrontare la tensione nominale e la corrente nominale degli apparecchi. Eseguire il cablaggio in base allo schema di collegamento riportato sul manuale del servoamplificatore. I collegamenti del motore sono indicati da capitolo "Wiring Diagrams" p.87.
- Assicurarsi che la messa a terra di servoamplificatore e motore venga eseguita a regola d'arte. Per una schermatura e una messa a terra conformi ai requisiti di compatibilità elettromagnetica si vedano le manuale del servoamplificatore utilizzato. Collegare a terra la piastra di montaggio e la carcassa del motore.
- Se possibile, posare separatamente cavi di potenza e di comando (distanza > 20 cm). La compatibilità elettromagnetica del sistema viene così migliorata. Se il cavo di potenza impiegato per il motore integra i conduttori di comando del freno questi ultimi devono essere schermati. La schermatura deve essere collegata su entrambe le estremità (vedere le istruzioni per l'installazione del servoamplificatore).
- Cablaggio
  - Se possibile, posare separatamente i cavi di potenza e di comando
  - Collegare l'unità di retroazione o encoder
  - Collegare i cavi del motore, l'induttore per motore vicino al Servoamplificatore
  - le schermature, su entrambe le estremità, ai morsetti o ai connettori EMC
  - Collegare l'eventuale il freno di stazionamento del motore.
  - Posare la schermatura su entrambi i lati
- Tutti i cavi che conducono correnti elevate devono avere sezione sufficiente secondo EN 30204. Le sezioni consigliate sono indicate nei dati tecnici.

**Informazioni** Nel caso del motore lungo cavo (>25m) ed il dipendente sul tipo del servoamplificatore utilizzato una scatola induttore (3YL / 3YLN) deve essere commutato nel cavo del motore (veda il manuale di istruzioni del servoamplificatore ed il manuale accessorio).

- Collegare le schermature in modo da coprire un'ampia superficie (a bassa impedenza), mediante un corpo connettore metallizzato o connettori filettati per cavi conformi ai requisiti sulla compatibilità elettromagnetica.

### 28.3 Collegamento dei motori

**Informazioni**

Gli schemi elettrici possono essere trovati nel capitolo "Wiring Diagrams" p.87.

- Eseguire il cablaggio in base alle disposizioni ed alle norme vigenti.
- Per il collegamento di potenza e di retroazione utilizzare esclusivamente i nostri cavi schermati preconfezionati.
- Posare le schermature in base agli schemi di collegamento riportati nelle manuale di istruzioni dei servoamplificatori.
- Le schermature non posate correttamente comportano immancabilmente disturbi elettromagnetici.
- Lunghezza dei cavi max.: attenersi manuali d'istruzione del servoamplificatore

Requisiti a materiale dei cavi:

**Capacità**

Cavo di motore	-	inferiore a 150 pF/m
Cavo die retroazione	-	inferiore a 120 pF/m

**Informazioni**

Per la descrizione dettagliata dei cavi confezionamento consultare il manuale degli accessori.

## 29 Messa in funzione

### 29.1 Indicazioni importanti

**⚠ AVVERTENZA**

- Solo tecnici con ampie conoscenze di elettrotecnica/tecniche di movimentazione possono mettere in funzione l'unità di azionamento con servoamplificatore/motore.
- Verificare che tutti gli elementi di collegamento sotto tensione siano protetti in modo sicuro contro il contatto. Presenza di tensioni letali fino a 900V.
- Non allentare mai i collegamenti elettrici dei motori sotto tensione. Le cariche residue nei condensatori dei servoamplificatori possono essere pericolose parecchi minuti dopo la disinserzione della tensione di rete.
- La temperatura superficiale del motore può varcare i 100°C durante il funzionamento. Verificare (misurare) la temperatura del motore. Prima di toccarlo attendere che abbia raggiunto i 40°C.
- Assicurarsi che anche in caso di spostamento accidentale dell'azionamento non possa sussistere alcun pericolo per la macchina o le persone.

### 29.2 Guida ad messa in funzione

A titolo di esempio descriviamo la procedura da seguire per la messa in funzione.

A seconda dell'impiego previsto può risultare opportuna o necessaria una procedura diversa.

- Controllare il montaggio e l'orientamento del motore.
- Verificare che gli elementi di azionamento (accoppiamento, trasmissione, puleggia) siano fissati nella relativa sede e che siano regolati correttamente (rispettare le forze radiali e assiali ammesse).
- Controllare il cablaggio e i collegamenti su motore e servoamplificatore. Assicurarsi che la messa a terra venga effettuata a regola d'arte.
- Controllare il funzionamento dell'eventuale freno di stazionamento. (Applicando 24V il freno deve essere rilasciato).
- Verificare se il rotore del motore può ruotare liberamente (rilasciare prima l'eventuale freno). Prestare attenzione ai rumori di sfregamento.
- Verificare che siano state adottate tutte le misure di protezione dal contatto necessarie per i componenti mobili e sotto tensione.
- Eseguire gli ulteriori controlli specifici e necessari per l'impianto in uso.
- Mettere in funzione l'azionamento in base alle istruzioni per la messa in funzione del servoamplificatore.
- In caso di sistemi multiasse mettere in funzione ogni unità di azionamento del servoamplificatore/motore singolarmente.

## 29.3

## Eliminazione dei guasti

La seguente tabella è da intendersi come una "cassetta di pronto soccorso". A seconda delle condizioni dell'impianto in uso diverse possono essere le cause di un'anomalia. Si descrivono prevalentemente le cause dei guasti che riguardano direttamente il motore. Eventuali anomalie nel comportamento normale sono generalmente da ricondursi ad un'impostazione errata dei parametri del servoamplificatore. Consultare a questo proposito la documentazione del servoamplificatore e del software operativo.

Nei sistemi multiasse le ragioni possono essere a monte, e occulte.

Il nostro settore applicazioni è comunque in grado di offrire un valido supporto.

Guasto	Cause possibili	Misure per l'eliminazione del guasto
<b>Il motore non gira</b>	<ul style="list-style-type: none"> <li>— Servoamplificatore non abilitato</li> <li>— Cavo valori nominali interrotto</li> <li>— Fasi motore scambiate</li> <li>— Freno non rilasciato</li> <li>— Azionamento bloccato meccanicamente</li> </ul>	<ul style="list-style-type: none"> <li>— Attivare il segnale ENABLE</li> <li>— Controllare il cavo valori nominali</li> <li>— Impostare le fasi del motore correttamente</li> <li>— Controllare il comando del freno</li> <li>— Controllare la meccanica</li> </ul>
<b>Motore fuorigiri</b>	<ul style="list-style-type: none"> <li>— Fasi motore scambiate</li> </ul>	<ul style="list-style-type: none"> <li>— Impostare le fasi del motore correttamente</li> </ul>
<b>Il motore oscilla</b>	<ul style="list-style-type: none"> <li>— Schermatura cavo resolver interrotta</li> <li>— Amplificazione eccessiva</li> </ul>	<ul style="list-style-type: none"> <li>— Sostituire il cavo resolver</li> <li>— Utilizzare i valori predefiniti del motore</li> </ul>
<b>Messaggio d'errore freno</b>	<ul style="list-style-type: none"> <li>— Cortocircuito nella linea di alimentazione della tensione del freno di arresto motore</li> <li>— Freno di stazionamento motore difettoso</li> </ul>	<ul style="list-style-type: none"> <li>— Eliminare il cortocircuito</li> <li>— Sostituire il motore</li> </ul>
<b>Messaggio d'errore stadio finale</b>	<ul style="list-style-type: none"> <li>— Il cavo motore è in cortocircuito o ha una dispersione a terra</li> <li>— Il motore è in cortocircuito o ha una dispersione a terra</li> </ul>	<ul style="list-style-type: none"> <li>— Sostituire il cavo</li> <li>— Sostituire il motore</li> </ul>
<b>Messaggio d'errore resolver</b>	<ul style="list-style-type: none"> <li>— Connettore resolver non inserito correttamente</li> <li>— Cavo resolver interrotto, schiacciato o similari</li> </ul>	<ul style="list-style-type: none"> <li>— Controllare il connettore</li> <li>— Controllare i cavi</li> </ul>
<b>Messaggio d'errore temperatura motore</b>	<ul style="list-style-type: none"> <li>— Interruttore termico del motore intervenuto</li> <li>— Connettore resolver allentato o cavo resolver interrotto</li> </ul>	<ul style="list-style-type: none"> <li>— Attendere fino a quando il motore si è raffreddato. Successivamente verificare la causa del surriscaldamento.</li> <li>— Controllare il connettore ed eventualmente inserire un nuovo cavo resolver</li> </ul>
<b>Il freno non fa presa</b>	<ul style="list-style-type: none"> <li>— Coppia di arresto richiesta eccessiva</li> <li>— Freno difettoso</li> <li>— Sollecitazione assiale albero motore</li> </ul>	<ul style="list-style-type: none"> <li>— Controllare la disposizione</li> <li>— Sostituire il motore</li> <li>— Controllare la sollecitazione assiale e ridurla. Sostituire il motore in quanto i cuscinetti sono danneggiati.</li> </ul>

## 30 Dati tecnici

**Informazioni** Per i dati tecnici di ogni tipo di motore consultare il capitolo "Technical Data" da p. 74.

Tutti i dati con la temperatura ambientale 40°C e la temperatura della bobina 100K aumentano. I dati possono avere una tolleranza di +/- 10%.

### 30.1 Definizioni

#### Coppia continuativa allo stallo $M_0$ [Nm]

La coppia continuativa allo stallo viene erogata ad un numero di giri  $0 < n < 100$  giri/min ed alle condizioni nominali per un periodo illimitato.

#### Coppia nominale $M_n$ [Nm]

La coppia nominale viene erogata quando il motore assorbe la corrente nominale al numero di giri nominale. La coppia nominale può essere erogata durante il funzionamento continuo (S1) al numero di giri nominale per un periodo illimitato.

#### Corrente continuativa allo stallo $I_{0rms}$ [A]

La corrente continuativa ad un numero di giri  $0 < n < 100$  giri/min è la corrente sinodale effettiva che il motore assorbe a riposo per poter erogare la coppia continuativa allo stallo.

#### Corrente di picco (corrente d'impulso) $I_{0max}$ [A]

La corrente di picco (valore effettivo sinodale) corrisponde a ca. 5 volte la corrente continuativa allo stallo. La corrente di picco del servoamplificatore utilizzato deve essere inferiore.

#### Costante di coppia $K_{Trms}$ [Nm/A]

La costante di coppia indica in Nm la coppia generata dal motore con una corrente sinodale effettiva di 1A. Vale  $M = I \times K_T$  (fino a max.  $I = 2 \times I_0$ )

#### Costante di tensione $K_{Erms}$ [mV/min]

La costante di tensione indica la forza elettromotrice indotta riferita al motore a 1000 giri/min. come valore effettivo sinodale tra due morsetti.

#### Momento di inerzia del rotore $J$ [kgcm<sup>2</sup>]

La costante  $J$  è una misura della capacità di accelerazione del motore. Con  $I_0$  si ottiene ad esempio il tempo di accelerazione  $t_b$  da 0 a 3000 giri/min.:

$$t_b \text{ [s]} = \frac{3000 \times 2\pi}{M_0 \times 60s} \times \frac{m^2}{10^4 \times cm^2} \times J \quad \text{con } M_0 \text{ in Nm e } J \text{ in kgcm}^2$$

#### Costante di tempo termica $t_{th}$ [min]

La costante  $t_{th}$  indica il tempo di riscaldamento del motore freddo con un carico di  $I_0$  fino al raggiungimento di una sovratemperatura di  $0,63 \times 100$  Kelvin. In caso di sollecitazione con corrente di picco, il riscaldamento ha luogo in un tempo notevolmente più breve.

#### Ritardo al rilascio $t_{BRH}$ [ms]/ritardo all'inserzione $t_{BRL}$ [ms] del freno

Le costanti indicano i tempi di reazione del freno di stazionamento applicando la tensione nominale al servoamplificatore.

#### $U_N$

Tensione di rete

#### $U_n$

Tensione di circuito intermedio.  $U_n = \sqrt{2} * U_N$



## 31 Generalidades

### 31.1 Sobre este manual

El presente manual describe los servomotores síncronos de la Serie AKM (modelo estándar).

Los motores son utilizados en el sistema de accionamiento junto con los servoamplificadores. Por este motivo, tenga presente la totalidad de la documentación del sistema, compuesta por:

- Instrucciones de instalación y de puesta en funcionamiento del servoamplificador
- Instrucciones de instalación y de puesta en funcionamiento de una tarjeta de ampliación eventualmente existente
- Manual del usuario de software de operadores del servoamplificador
- Manual de accesorios
- Descripción técnica de la serie de motores AKM

Más información de fondo se puede encontrar en nuestro "Producto WIKI", disponible en [www.wiki-kollmorgen.eu](http://www.wiki-kollmorgen.eu).





### 31.2 Destinatarios

Este manual está dirigido a personal especializado y establece los siguientes requisitos:

- Transporte: sólo a cargo de personal con conocimientos de manejo de elementos de montaje con riesgo electrostático
- Instalación mecánica: sólo a cargo de personal especializado con formación en ingeniería mecánica
- Instalación eléctrica: sólo a cargo de personal especializado con formación en electrotecnia
- Puesta en funcionamiento: sólo a cargo de personal especializado con amplios conocimientos sobre electrotecnia y la técnica de accionamientos
- El personal especializado deberá conocer y observar las siguientes normas y directrices:  
IEC 60364 y IEC 60664  
Normativa nacional de prevención de accidentes

**⚠ ADVERTENCIA** Durante el funcionamiento de los motores existe peligro de muerte, de riesgos graves para la salud o de daños materiales. Por este motivo, el operador debe asegurarse de que se cumplan las instrucciones de seguridad incluidas en este manual. El operador debe cerciorarse de que todas las personas que vayan a realizar trabajos en el motor hayan leído y comprendido el manual del producto.

### 31.3 Símbolos utilizados

Símbolos	Indication
 <b>PELIGRO</b>	Indica una situación peligrosa que, si no se evita, ocasionará la muerte o lesiones graves.
 <b>ADVERTENCIA</b>	Indica una situación peligrosa que, si no se evita, puede ocasionar la muerte o lesiones graves.
 <b>ATENCIÓN</b>	Indica una situación peligrosa que, si no se evita, puede ocasionar lesiones leves o moderadas.
 <b>INDICACIÓN</b>	Indica situaciones que, si no se evitan, pueden provocar daños materiales.
 <b>INFORMACIÓN</b>	Éste no es un símbolo de seguridad. Este símbolo indica notas importantes.

### 31.4 Abreviaturas utilizadas

Véase capítulo 40.1 "Definiciones".

## 32 Seguridad

### 32.1 Instrucciones de seguridad

#### ▲ ADVERTENCIA

- El fabricante de la máquina elaborará un análisis de riesgo de la máquina y adoptará las medidas adecuadas para que movimientos imprevistos no puedan causar daños personales ni materiales.
- Asegúrese de la adecuada puesta a tierra del bloque del motor con la barra colectora del armario de distribución como potencial de referencia. Careciendo de una toma de tierra de baja resistencia no se puede garantizar la seguridad personal.
- No extraiga ningún enchufe con el equipo en marcha. Existe peligro de muerte, de riesgos graves para la salud y de daños materiales.
- Las conexiones pueden llevar tensión, incluso con el motor parado. No suelte nunca las conexiones eléctricas estando bajo tensión. En circunstancias desfavorables se pueden producir chispazos que dañen a las personas y a los contactos.
- Al desconectar el servoamplificador de la corriente de alimentación, espere varios minutos antes de soltar piezas conductoras de corriente (por ejemplo, contactos, pernos, etc.). Los condensadores en el servoamplificador conducen tensiones peligrosas hasta unos varios minutos después de cortar la alimentación de corriente. Para mayor seguridad, mida la corriente en el circuito intermedio y espere a que la corriente se sitúe por debajo de 40V.
-  Durante el funcionamiento, los motores pueden tener superficies calientes según la clase de protección. La temperatura de las superficies puede alcanzar 100°C. Mida la temperatura y, antes de tocar el motor, espere hasta que se haya enfriado a 40°C.
- Si el motor gira libremente, quite/fije el muelle de ajuste que pueda existir, para evitar que salga despedido con el consiguiente peligro de accidente.
- I freni di stazionamento integrati non garantiscono la sicurezza del personale! In presenza di carichi sospesi (assi verticali) è necessario utilizzare un freno meccanico esterno aggiuntivo per garantire la sicurezza del personale.

#### ▲ ATENCIÓN

- Las operaciones de transporte, instalación, puesta en funcionamiento y mantenimiento sólo podrán ser realizadas por personal cualificado. Por personal cualificado se entiende las personas que están familiarizadas con el transporte, la instalación, el montaje, la puesta en funcionamiento y el manejo del producto y que disponen de las correspondientes calificaciones profesionales. El personal especializado deberá conocer y observar las siguientes normas y directrices:  
IEC 60364 y IEC 60664  
Normativa nacional de prevención de accidentes
- Antes del montaje y de la puesta en funcionamiento, lea detenidamente la presente documentación. La incorrecta manipulación del motor puede producir daños personales y materiales. La observación de los datos técnicos y las indicaciones de conexión (placa de identificación y documentación) son de obligado cumplimiento.

## 32.2

### Utilización conforme

- Los servomotores sincrónicos de la Serie AKM están diseñados especialmente para el accionamiento de equipos de manipulación, maquinaria textil, máquinas-herramientas, maquinaria de embalaje y similares con elevados requerimientos dinámicos.
- Están **solamente** autorizados a operar en motores cumpliendo las condiciones del entorno definidas en la presente documentación.
- Los motores de la Serie AKM está **exclusivamente** destinados a ser activados mediante servoamplificadores digitales regulados por velocidad y/o por par motor.
- Los motores se montan como componentes de instalaciones eléctricas o maquinaria y solamente pueden ser puestos en servicio como componentes integrados.
- El contacto de termoprotección incorporado en el arrollamiento del motor será evaluado y comprobado.
- Los frenos están diseñados como frenos de parada y no son adecuados para operaciones de frenado permanentes durante el servicio.
- Garantizamos la conformidad del servosistema con los términos de la EC Declaration of Conformity de la página 60, solamente cuando se utilicen los componentes entregados por nosotros (servoamplificador, motor, cables, etc.).

## 32.3

### Uso indebido

- Está prohibido utilizar los motores en los siguientes entornos:
  - Zonas con riesgo de explosión y entornos con polvos, vapores, aceites, lejías y ácidos corrosivos o conductores de electricidad
  - Funcionamiento directo en la red
- Está prohibido utilizar el motor si la máquina en la que está instalado:
  - no cumple las disposiciones de la directiva comunitaria sobre máquinas;
  - no cumple las disposiciones de la directiva sobre compatibilidad electromagnética;
  - no cumple las disposiciones de la directiva sobre equipos de baja tensión.
- A fin de garantizar la seguridad del personal, no se deben utilizar frenos de detención integrados sin un equipo adicional.

**33 Normas válidas****33.1 EC Declaration of Conformity**

We, the company

Kollmorgen Europe GmbH  
Pempelfurtstraße 1  
D-40880 Ratingen

hereby in sole responsibility declare the conformity of the product series

**Motor series AKM**

**(Types AKM1, AKM2, AKM3, AKM4, AKM5, AKM6, AKM7, AKM8)**

with the following standards:

- EC Directive 2004/108/EC  
Electromagnetic compatibility  
Used standard EN61800-3:07/2005
- EC Directive 2006/95/EC  
Electrical devices for use in special voltage limits  
Used standard EN61800-5-1:04/2008

Year of EC-Declaration      2003

Issued by:                      Product Manager Motors Europe  
   Jörg Peters  
   Ratingen, 01.12.2010

Legally valid signature



This Declaration does not contain any assurance of properties in the meaning of product liability.

The notes on safety and protection in the operating instructions must always be observed.

The above-mentioned company has the following technical documentation for examination:

- Proper operating instructions
- Diagrams (for EU authority only)
- Test certificates (for EU authority only)
- Other technical documentation (for EU authority only)

## 34 Manipulación

### 34.1 Transporte

- Temperatura -25...+70° C, oscilación máx. 20K / hora  
Humedad del aire humedad relativa máx. 5%... 95% sin condensar
- Sólo a cargo de personal especializado en el envase original reciclable del fabricante
- Evite impactos fuertes, particularmente sobre el extremo del eje
- En caso de que el embalaje esté dañado, compruebe que el aparato no tiene daños visibles. Informe de ello al transportista y, en caso necesario, al fabricante.

Utilice las argollas de elevación suministradas para el transporte seguro de los motores AKM8. Respete las instrucciones relativas al transporte incluidas en el embalaje del motor. Recomendamos la herramienta ZPZM 120/292 del transporte para mover los motores AKM8. La unidad ZPMZ 120/292 de la suspensión consiste en una viga, suspendida al gancho de la grúa y dos doble-funcionan las ligas de cadena.

#### **PELIGRO**

**¡La zona bajo la carga debe estar despejada durante la elevación!**

- Los tornillos de fijación de las argollas de elevación han de estar completamente enroscados.
- Las argollas de elevación deben asentarse totalmente planas en la superficie de apoyo.
- Antes de utilizarlas, comprobar si las argollas de elevación están firmemente asentadas y si presentan daños visibles (corrosión, deformación).
- Las argollas de elevación deformadas no deben utilizarse.

B1/ 4 x LIFTING BOLT PLUS LIFTING BEAM

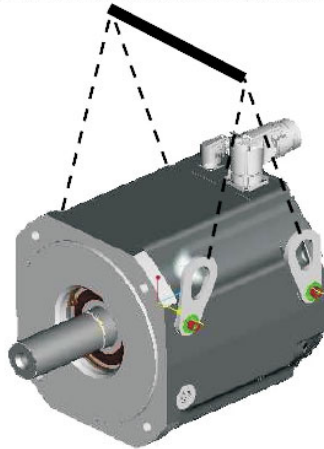

B2/ 2 x LIFTING BOLT PLUS LIFTING BEAM

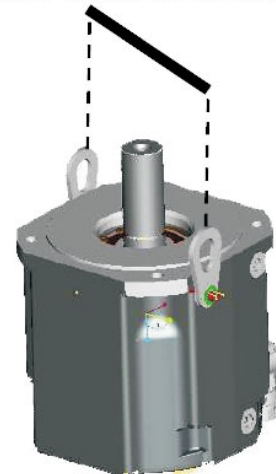

B3/ 2 x LIFTING BOLT PLUS LIFTING BEAM



## 34.2 Embalaje

- Caja de cartón amortiguador de la espuma de Instapak®.
- Usted puede volver la porción plástica al surtidor (véase la "Eliminación").

Modelo	Embalaje	Altura máx. de estiba	Modelo	Embalaje	Altura máx. de estiba
AKM1	Caja de cartón	10	AKM5	Caja de cartón	5
AKM2	Caja de cartón	10	AKM6	Caja de cartón	1
AKM3	Caja de cartón	6	AKM7	Caja de cartón	1
AKM4	Caja de cartón	6	AKM8	Paleta	1

## 34.3 Almacenamiento

- Temp. de almacenamiento -25...+55°C, oscilación máx. 20K/hora
- Humedad del aire humedad rel. máx. 5% ... 95% sin condensar
- Sólo en el embalaje original reciclable del fabricante
- Altura máx. de apilamiento véase en la tabla de embalaje
- Tiempo de almacenamiento sin limitación

## 34.4 Advertencia / Limpieza

- Advertencia / limpieza sólo por personal profesional
- Después de 20.000 horas de servicio en condiciones nominales, se deberían cambiar los cojinetes.
- Compruebe el motor cada 2500 horas de servicio, o bien, una vez al año para ruidos en los cojinetes. Si escucha ruidos en los cojinetes, detenga inmediatamente el motor y cambie los cojinetes
- La apertura de los motores trae consigo la pérdida de la garantía
- Límpiense con isopropanol o producto similar **no sumergir ni pulverizar**

## 34.5 Reparación

Sólo el fabricante debe ejecutar reparaciones en el motor; la apertura de los aparatos invalida la garantía. Ponga el aparato fuera de servicio y envíelo al fabricante:

Kollmorgen Europe GmbH  
Pempelfurtstraße 1  
D-40880 Ratingen

## 34.6 Eliminación

De conformidad con la directiva 2002/96/CE (RAEE), nos encargamos de eliminar de manera adecuada los aparatos y accesorios viejos si el remitente se hace cargo de los gastos de transporte. Envíe los aparatos a

Kollmorgen Europe GmbH  
Pempelfurtstraße 1  
D-40880 Ratingen

## 35 Identificación del producto

### 35.1 Volumen de suministro

- Motor de la Serie AKM
- Manual del producto (lengua multi)

### 35.2 Placa de identificación

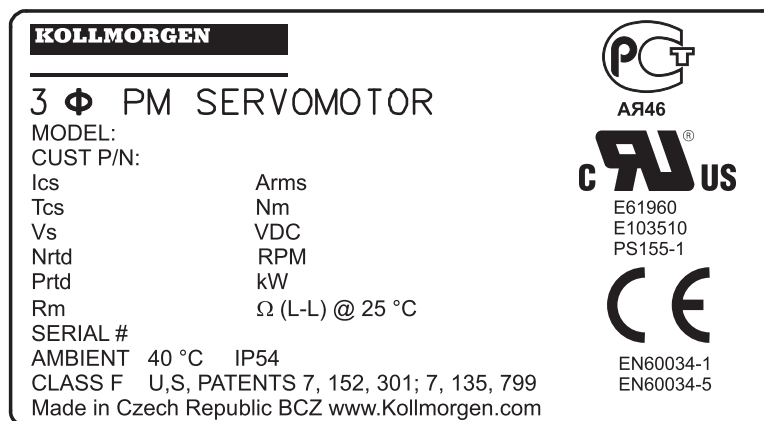

#### Leyenda:

MODEL	Modelo
CUST P/N	número de pieza del cliente
Ics	I <sub>0rms</sub> (Corriente de parada)
Tcs	M <sub>0</sub> (Par motor de parada)
Vs	U <sub>n</sub> (Tensión del circuito intermedio)
Nrtd	nn (Velocidad nominal @ U <sub>n</sub> )
Prtđ	Pn (Potencia nominal)
Rm	R25 (Resistencia de la bobina @ 25°)
SERIAL	Número de serie
AMBIENT	Temperatura ambiental máx.

El año de fabricación se cifra en el número de serie: los primeros dos dígitos del número de serie son el año de fabricación, e.g. "07" significa 2007.

35.3

Codificación de modelo

**AKM 6 2 P - A N C N DA 00**

**Tamaño del Brida**  
 1 40mm  
 2 58mm  
 3 70mm  
 4 84mm  
 5 108mm  
 6 138mm  
 7 188mm  
 8 260mm

**Longitud del rotor**  
 1  
 2  
 3  
 4  
 5

**Tipo Bobina**  
 A .. Z  
 S especial

**Tipo del brida**  
 A IEC precisión N  
 B NEMA  
 C alternativa IEC  
 D otro norma  
 G alternativa IEC  
 H alternativa IEC  
 M,T cojinete reforzado AKM8  
 R IEC precisión R  
 S especial

**Eje**  
 C con ranura  
 K ranura abierto  
 N sin ranura  
 S especial

**Realización**  
 00 estándar  
 01 con retén radial  
 OW Washdown  
 OF Washdown Food  
 xx especial

**Unidad de retorno**  
 1- Comcoder con 1024 Inkr/U  
 2- Comcoder con 2048 Inkr/U  
 AA Acuro(Biss) Single Turn  
 AB Acuro(Biss) Multi Turn  
 C- Smart Feedback Device  
 DA ECN1x13 (no RoHS conf.)  
 DB EQN1x25 (no RoHS conf.)  
 LA ECI 1118/1319 Single Turn  
 LB EQI 1130/ 1331 Multi Turn  
 GA HIPERFACE Single Turn  
 GB HIPERFACE Multi Turn  
 R- Resolver  
 S- especial

**Freno**  
 2 con Freno 24V  
 N sin freno  
 S especial

**Técnica de conexión**  
 B conectores en ángulo girables (AKM2)  
 C cable apantallado de 0,5 m con conector (AKM1/2), conectores en ángulo girables (AKM3..7)  
 D onector único en ángulo girable (AKM2/3/4 con SFD, sin freno)  
 G conector recto (AKM2..7)  
 H conector de potencia IP65, tamaño 1.5 sólo para AKM74Q& AKM82  
 M cable apantallado de 0,5 m con conectores IP20 (In < 6A)  
 P cable apantallado de 0,5 m con un único conector IP20 (In < 6A y SFD)  
 T caja de bornes para conector de realimentación y potencia, tamaño (AKM8)  
 S especial

ESPAÑOL



## 36 Descripción técnica

### 36.1 Datos técnicos generales

<b>Temperatura ambiente (con datos nominales)</b>	5...+40°C con altura de emplaz. hasta 1000m sobre nivel del mar Con temperaturas ambiente superiores a 40°C y con montaje encapsulado de los motores, tome contacto siempre con nuestro Departamento de Aplicaciones.
<b>Humedad autorizada (con datos nominales)</b>	95% humedad relativa, sin formación de rocío
<b>Reducción de potencia</b>	1%/K en el rango 40°C...50°C hasta 1000 m sobre el nivel del mar (Corrientes y momentos) con alturas de emplazamiento superiores a 1000 m sobre el nivel del mar y 40°C 6% a 2000 m sobre el nivel del mar 17% a 3000 m sobre el nivel del mar 30% a 4000 m sobre el nivel del mar 55% a 5000 m sobre el nivel del mar Sin reducción de potencia a alturas de emplazamiento superiores a 1000 m sobre el nivel del mar y reducción de temperatura en 10K / 1000m
<b>Vida útil de cojinetes</b>	≥ 20.000 horas de servicio

#### INFORMACIÓN

A partir de la página 74 del capítulo "Technical Data" encontrará los datos técnicos correspondientes a cada tipo de motor.

### 36.2 Modelo estándar

#### 36.2.1 Forma de diseño

La forma básica de diseño de los servomotores AKM es la forma IM B5 según EN 60034-7.

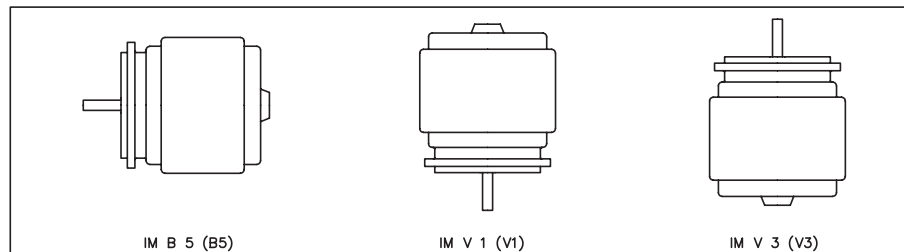

#### 36.2.2 Brida

Dimensiones de brida según Norma IEC, ajuste j6, precisión según DIN 42955  
Clase de tolerancia : **N**, opcional R per brida del IEC

#### 36.2.3 Tipo de protección

Modelo AKM1-4 estándar con conector M o P con o sin retén radial	IP20
Modelo AKM1 estándar con conector C sin retén radial	IP40
Modelo AKM2-AKM8 estándar con conector B, C, D, G, H, T sin retén radial	IP54
Modelo AKM1-AKM8 estándar con conector B, C, D, G, H, T con retén radial	IP65

#### 36.2.4 Clase de material aislante

Los motores cumplen con la clase F de materiales aislantes según IEC 60085 (UL 1446 class F).

#### 36.2.5 Superficie

Los motores están cubiertos con la capa del polvo del poliéster en negro mate, no siendo resistente a disolventes (Tri, diluyentes, etc.).

### 36.2.6 Extremo del eje, lado de accionamiento

La transmisión de fuerza resulta a través del extremo cilíndrico A (ajuste k6) según EN 50347 con rosca de apriete (hasta DBL1/DBL2) pero **sin ranura del muelle de ajuste**. Para la vida útil de los cojinetes se ha partido de 20.000 horas de servicio.

#### Fuerza radial:

Si los motores propulsan a través de piñones o correas dentadas, se presentan elevadas fuerzas radiales. Los valores autorizados en el extremo del eje, en función de velocidad, se indican en los diagramas en capítulo "Drawings" de la pag.87. Los valores máximos permitidos figuran en los datos técnicos. Con aplicación de fuerza en el centro del extremo libre del eje  $F_R$  10% puede ser mayor.

#### Fuerza axial

Cuando se montan piñones o poleas en el eje y se utilizan p. ej. engranajes angulares, se producen fuerzas axiales. Los valores máximos permitidos figuran en los datos técnicos.

#### Acoplamiento

Como elementos ideales de acoplamiento sin juego han dado muy buen resultado las tenazas tenzoras, también en unión con acoplamientos de fuelle metálico.

### 36.2.7 Dispositivo protector

El modelo estándar del motor va equipado con un PTC sin potencial. El punto de conexión se encuentra a  $155^\circ\text{C} \pm 5\%$ . El PTC **no** protege contra sobrecargas instantáneas muy altas. Utilizando nuestro conductor resolver preconfeccionado, el dispositivo de termoprotección está integrado en el sistema de control del servoamplificador digital.

### 36.2.8 Calidad vibracional

Los motores se fabrican con el factor A de calidad vibracional según DIN EN 60034-14. Esto implica que el nivel de vibraciones permitido como valor efectivo para un rango de velocidades de 600-3600 rpm y una altura del eje de entre 56-132 mm es de 1,6 mm/s.

Velocidad [rpm]	max. rel. Dislocación Vibratoria [ $\mu\text{m}$ ]	max. Run-out [ $\mu\text{m}$ ]
$\leq 1800$	90	23
$> 1800$	65	16

### 36.2.9 Freno de detención

Los motores AKM2-AKM8 se pueden suministrar opcionalmente con freno de detención incorporado. En freno magnético permanente (24 V CC) bloquea el rotor cuando está sin tensión.

**⚠ ADVERTENCIA** En el caso de las cargas suspendidas (ejes verticales), sólo se puede garantizar la seguridad personal mediante el uso de un freno mecánico adicional externo. Cuando se ha desfrenado, el rotor se puede mover sin momento residual y el modo de trabajo es sin juego.

**⚠ ATENCIÓN** Los frenos están diseñados como frenos de parada y no son adecuados para operaciones de frenado permanentes durante el servicio. Si el freno se acciona muy frecuentemente durante el servicio, es probable que el freno de detención se desgaste prematuramente y falle.

La longitud del motor aumenta con el freno de parada montado.

Los frenos de detención pueden ser activados directamente por el servoamplificador de Kollmorgen (con riesgo para las personas) liberando a continuación el arrollamiento de freno en el servoamplificador, y no siendo necesaria una conexión adicional. Consulte a este respecto las instrucciones de servicio del servoamplificador.

Cuando el freno de detención no es activado directamente por el servoamplificador se debe realizar una conexión adicional (p.ej., un varistor). Consulte a nuestro Departamento de Aplicaciones.

## 37 Instalación mecánica

**INFORMACIÓN** Los dibujos de la dimensión se pueden encontrar en capítulo "Dimension Drawings" p. 87.

### 37.1 Instrucciones importantes

**ATENCIÓN** Solamente los profesionales con conocimientos de mecánica están autorizados a montar.

- Proteja los motores contra esfuerzos excesivos. Especialmente durante el transporte y la manipulación, no se deberán doblar componentes, ni modificar las distancias de aislamiento.
- El lugar de instalación se encontrará libre de materiales conductores y agresivos. Durante el montaje del V3 (extremo del eje hacia arriba), ponga atención a que no penetren líquidos en los cojinetes. Antes de realizar el montaje encapsulado, consulte a nuestro Departamento de Aplicaciones.
- Asegúrese de la ventilación sin obstáculos de los motores, respetando la temperatura ambiente y la temperatura de la brida. Con temperaturas superiores a 40 °C, consulte previamente con nuestro Departamento de Aplicaciones. Procure la suficiente evacuación del calor en el entorno y en la brida del motor para no superar la temperatura máxima autorizada de 65 °C en la brida del motor.
- Los servomotores son equipos de precisión. Especialmente la brida y el eje corren peligro durante el almacenamiento y montaje. Evite el empleo de la fuerza, pues la precisión exige sensibilidad. En la colocación de acoplamientos, piñones y poleas para correas, utilice siempre la rosca prevista del eje del motor y, siempre que sea posible, caliente los elementos de salida. Los golpes y el empleo de la fuerza producen daños en los cojinetes y en el eje.

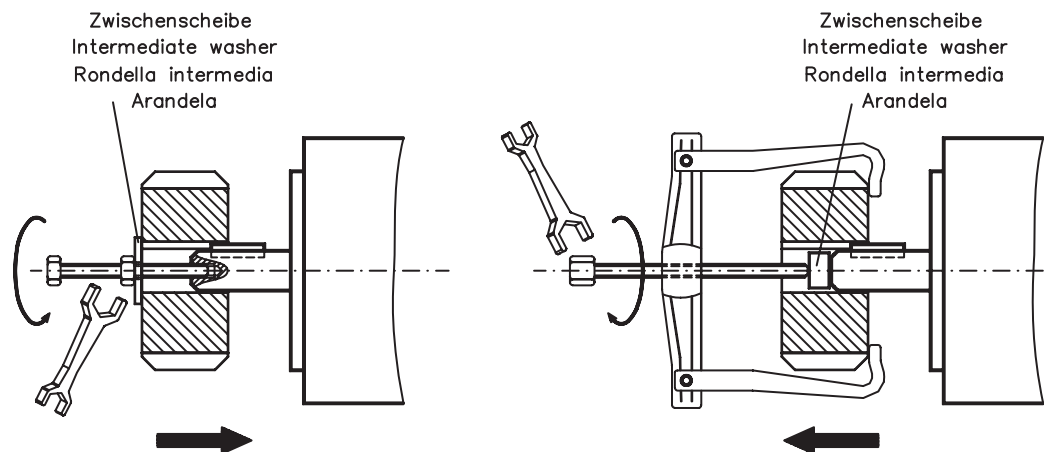

- Utilice siempre en lo posible tenazas tensoras sin holguras, tenazas de fricción, o acoplamientos como. Procure siempre la correcta alineación del acoplamiento. Las desviaciones producen vibraciones inadmisibles y destrozos en los cojinetes y en el acoplamiento.
- Cuando utilice correas dentadas, verifique siempre las fuerzas radiales autorizadas. Los esfuerzos radiales excesivos del eje reducen mucho la vida útil del motor.
- Evite en lo posible los esfuerzos axiales del eje del motor. Los esfuerzos axiales excesivos del eje reducen mucho la vida útil del motor.
- Evite siempre una suspensión mecánica sobredeterminada del eje del motor a través de un acoplamiento rígido y de suspensión adicional externa (por ejemplo, en el engranaje).
- Observe el número de polos del motor y del resolver y ajuste correctamente los números de polos. El ajuste incorrecto puede producir la destrucción sobre todo de los motores pequeños.
- Controle las cargas radiales y axiales autorizadas  $F_R$  y  $F_A$ . Utilizando un accionamiento por correa dentada, el diámetro **mínimo** autorizado del piñón se obtiene según la ecuación siguiente:  $d_{\min} \geq \frac{M_0}{F_R} \times 2$ .

## 38 Instalación eléctrica

### INFORMACIÓN

Los esquemas eléctricos se pueden encontrar en capítulo "Wiring Diagrams" de la pag.87. Pinout del amplificador se puede encontrar en el manual del amplificador.

### 38.1 Instrucciones de seguridad

#### ▲ADVERTENCIA

Solamente los profesionales con conocimientos de electrotecnia están autorizados a cablear el motor.

El montaje y cableado de los motores se realizará siempre sin tensión, es decir, ninguna de las tensiones de servicio del aparato a conectar deberá estar activada. Asegúrese de que la desconexión del armario de distribución sea segura (bloqueo, rótulos de advertencia, etc.).

Las diferentes tensiones se conectarán en la primera puesta en funcionamiento.

No manipule nunca las conexiones eléctricas de los motores cuando se encuentren bajo tensión. Las cargas residuales en los condensadores del servoamplificador pueden presentar valores peligrosos incluso varios minutos después de desconectar de la red. Mida la tensión en el circuito intermedio y espere hasta que haya descendido por debajo de 40 V. Las conexiones de control y de potencia pueden provocar tensión, incluso aunque el motor no esté girando.

### INFORMACIÓN

El símbolo de masa , que se encuentra en todos los planos de conexión, indica que debe asegurarse de realizar una conexión en el armario de distribución con la mayor superficie posible conductora de electricidad, entre el aparato que lleva la indicación y la placa de montaje. Esta conexión hará posible la derivación de interferencias de alta frecuencia y no debe confundirse con la marca PE (medida de protección según EN 60204). Respete también las indicaciones en los planos de conexión de las manual de instalación y de puesta en funcionamiento del servoamplificador utilizado.

### 38.2 Guía de instalación eléctrica

- Compruebe la correspondencia entre el servoamplificador y el motor. Compare la tensión nominal y la corriente nominal de los aparatos. Realice el cableado conforme al cuadro de conexiones de las Instrucciones de instalación y de puesta en funcionamiento del servoamplificador. Las conexiones del motor se encuentran en capítulo "Wiring Diagrams" pag.87.
  - Asegúrese de que la toma de tierra del servoamplificador y del motor esté perfectamente instalada. Véanse la adecuada protección de compatibilidad electromagnética y de puesta a tierra en las Instrucciones de instalación del servoamplificador utilizado. Ponga a tierra la placa de montaje y el bloque del motor..
  - Tienda los cables de potencia y de control suficientemente espaciados (distancia > 20 cm). Así mejorará la compatibilidad electromagnética del sistema. Utilizando un cale de potencia del motor con conductores de mando de freno integrados, estos deberán estar apantallados. La pantalla estará dispuesta por ambos lados (véase manual de instalación del servoamplificador).
  - Cableado
    - Tienda los cables de potencia y de control bien separados
    - Conecte el resolver y el codificador
    - Conecte los cables del motor cerca del servoamplificador
    - Apantallamientos a ambos lados en bornes de protección o en el enchufe de CEM
    - Conecta el freno de detención, si está montado.
    - Coloque el apantallamiento a ambos lados
  - Realice el tendido de todos las conducciones de alta tensión con sección suficiente según EN 60204. En los datos técnicos se incluyen las secciones recomendadas.
- En función del tipo de servoamplificador utilizado, con cables de motor largos (> 25 m) debe conectarse una bobina de motor (3YL o 3YLN) en el conductor del motor (véase el manual de producto del servoamplificador y el manual de accesorios).**
- Realice apantallamientos de gran superficie (baja resistencia) a través de cajas de enchufe metalizadas, o bien, de uniones de cable roscadas compatibles electromagnéticamente.

### INFORMACIÓN

### 38.3 Conexión de los motores

**INFORMACIÓN**

Los esquemas eléctricos se pueden encontrar en capítulo "Wiring Diagrams" de la pag.87.

- Realice el cableado cumpliendo los reglamentos y normas vigentes.
- Para las conexiones de potencia y de retorno, utilice exclusivamente nuestras conducciones preconfeccionadas y protegidas.
- Coloque los apantallamientos en la forma indicada en las figuras de las Instrucciones de instalación de los servoamplificadores.
- Los apantallamientos mal colocados producen siempre a interferencias electromagnéticas.
- La longitud máxima del conductor se define en el manual de producto del servoamplificador utilizado.

Requisitos al material de cables:

**Capacidad**

Cable del motor	-	menor que 150 pF/m
Cable Resolver	-	menor que 120 pF/m

**INFORMACIÓN**

Para una descripción detallada de cables premontados, refiera por favor a los manuales accesorios.

## 39 Puesta en funcionamiento

### 39.1 Instrucciones importantes

**⚠ ADVERTENCIA**

- Solamente los profesionales con amplios conocimientos de electrotecnia y de técnicas de accionamiento están autorizados a la puesta en funcionamiento del conjunto servoamplificador-motor.
- Compruebe que todas las piezas de conexión que conducen tensión estén protegidas contra cualquier posible contacto. Se producen tensiones peligrosas de hasta 900V.
- No manipule nunca las conexiones eléctricas de los motores cuando se encuentren bajo tensión. Las cargas residuales en los condensadores del servoamplificador pueden presentar valores peligrosos incluso varios minutos después de desconectar de la red.
- La temperatura de la superficie del motor puede alcanzar 100 °C durante el servicio. Compruebe (mida) la temperatura del motor. Espere a que la temperatura haya descendido a 40 °C antes de tocar el motor con las manos.
- Asegúrese de que, incluso con movimientos involuntarios del motor, no puedan existir peligros para las personas y para la máquina.

### 39.2 Guía de puesta en funcionamiento

La forma de proceder en la puesta en accionamiento se describe a modo de ejemplo. Dependiendo del tipo de puesta en servicio de los aparatos puede ser adecuado o necesario un procedimiento u otro.

- Compruebe el montaje y la alineación del motor.
- Compruebe el firme asiento de los elementos de salida de fuerza (acoplamiento, engranaje, polea de la correa) así como el ajuste correcto (respetar las fuerzas radiales y axiales autorizadas).
- Compruebe el cableado y las conexiones del motor y del servoamplificador. Compruebe la correcta puesta a tierra.
- Compruebe el funcionamiento del freno de detención, si está montado. (conectar 24V, el freno se debe soltar).
- Compruebe si el rotor del motor gira libremente (soltar primero el freno, si está montado). Compruebe si se escuchan ruidos de fricción.
- Compruebe si se han tomado todas las medidas de protección contra contactos para las piezas móviles y las conductoras de tensión.
- Realice todas las comprobaciones específicas y necesarias para su equipo.
- Conforme a las Instrucciones de puesta en funcionamiento del servoamplificador, ponga ahora en marcha el accionamiento.
- En sistemas de varios ejes, ponga en marcha, una a una, cada una de las unidades de accionamiento servoamplificador-motor.

## 39.3

## Eliminación de perturbaciones

Interprete la siguiente tabla como un botiquín de "Primera Ayuda". Las condiciones en que se ha procedido a la instalación determinan las causas por las que se produce una avería. En primer lugar se describen las causas de fallos que pueden afectar directamente al motor. Las incidencias que se presentan en el comportamiento de regulación tienen normalmente su origen en la parametrización errónea del servoamplificador. Vea la información al respecto en la documentación del servoamplificador y en el software de puesta en funcionamiento.

En el caso de sistemas poliaxiales, pueden existir otros defectos ocultos.

Nuestro Departamento de Aplicaciones se esforzará por resolver todos sus problemas.

Error	Causas posibles	Medidas para la eliminación de fallos errores
<b>El motor no gira</b>	<ul style="list-style-type: none"> <li>— No accionar el servoamplificador</li> <li>— Conductor de valor nominal cortado</li> <li>— Fases del motor cambiadas</li> <li>— No se ha accionado el freno</li> <li>— El accionamiento está bloqueado mecánicamente</li> </ul>	<ul style="list-style-type: none"> <li>— Conectar la señal ENABLE</li> <li>— Comprobar el conductor de valor nominal</li> <li>— Fijar correctamente las fases del motor</li> <li>— Comprobar el control de los frenos</li> <li>— Comprobar parte mecánica</li> </ul>
<b>Motor gira demasiado</b>	<ul style="list-style-type: none"> <li>— Fases del motor cambiadas</li> </ul>	<ul style="list-style-type: none"> <li>— Fijar correctamente las fases del motor</li> </ul>
<b>El motor vibra</b>	<ul style="list-style-type: none"> <li>— Interrumpida la protección del conductor del resolver</li> <li>— Amplificación excesiva</li> </ul>	<ul style="list-style-type: none"> <li>— Cambiar el conductor del resolver</li> <li>— Utilizar valores por defecto del motor</li> </ul>
<b>Aviso de error del freno</b>	<ul style="list-style-type: none"> <li>— Cortocircuito el conductor de entrada de tensión del freno de detención del motor</li> <li>— Freno de detención del motor defectuoso</li> </ul>	<ul style="list-style-type: none"> <li>— Eliminar cortocircuito</li> <li>— Cambiar el motor</li> </ul>
<b>Aviso de error de estado final</b>	<ul style="list-style-type: none"> <li>— Cable del motor tiene cortocircuito o contacto a tierra</li> <li>— El motor tiene cortocircuito o contacto a tierra</li> </ul>	<ul style="list-style-type: none"> <li>— Cambiar el cable</li> <li>— Cambiar el motor</li> </ul>
<b>Aviso de error de resolver</b>	<ul style="list-style-type: none"> <li>— El enchufe del resolver no está bien insertado</li> <li>— El cable del resolver está interrumpido</li> </ul>	<ul style="list-style-type: none"> <li>— Verificar la conexión</li> <li>— Comprobar los conductores</li> </ul>
<b>Aviso de error de temperatura del motor</b>	<ul style="list-style-type: none"> <li>— El termointerruptor del motor se ha activado</li> <li>— Enchufe del resolver suelto o cable del resolver interrumpido</li> </ul>	<ul style="list-style-type: none"> <li>— Esperar a que el motor se enfríe. Comprobar después por qué el motor se ha calentado</li> <li>— Comprobar el enchufe y cambiarlo, si es preciso Colocar el cable del resolver</li> </ul>
<b>Freno no actúa</b>	<ul style="list-style-type: none"> <li>— Momento de detención exigido excesivamente alto</li> <li>— Freno defectuoso</li> <li>— Eje del motor con sobrecarga axial</li> </ul>	<ul style="list-style-type: none"> <li>— Comprobar dimensionamiento</li> <li>— Cambiar el motor</li> <li>— Verificar la carga axial y reducirla. Cambiar el motor, pues están dañados los cojinetes</li> </ul>

## 40 Datos técnicos

### INFORMACIÓN

A partir de la página 74 del capítulo "Technical Data" encontrará los datos técnicos correspondientes a cada tipo de motor.

Todos los datos válidos para la temperatura ambientales de 40°C y la temperatura excesiva de la bobina 100K . Los datos pueden tener una tolerancia de el +/- 10%.

### 40.1 Definiciones

#### Par motor de parada $M_0$ [Nm]

El par motor de parada puede ser entregado durante un tiempo ilimitado desde un velocidad de  $0 < n < 100 \text{ min}^{-1}$  y en condiciones ambientales nominales.

#### Par motor nominal $M_n$ [Nm]

El par motor nominal se entrega cuando el motor es alimentado con la corriente nominal a velocidad nominal. El par motor nominal puede ser entregado durante un tiempo ilimitado en servicio continuo (S1) al velocidad nominal.

#### Corriente de parada $I_{0rms}$ [A]

La corriente de parada es el valor efectivo de la corriente sinusoidal que recibe el motor al  $0 < n < 100 \text{ min}^{-1}$ , para poder entregar el par motor de parada.

#### Corriente máxima (corriente pulsatoria) $I_{0max}$ [A]

La corriente máxima (valor sinusoidal eficaz) es aproximadamente equivalente a 5-times la corriente de parada. El valor real es determinado por la corriente máxima del servoamplificador se utiliza que.

#### Constante de par motor $K_{Trms}$ [Nm/A]

La constante indica el par motor en Nm que genera el motor con 1A de corriente efectiva sinusoidal.  $M = I \times K_T$  (hasta un máximo de  $I = 2 \times I_0$ )

#### Constante de tensión $K_{Erms}$ [mV/min]

La constante de tensión indica la fuerza electromotriz inducida del motor referida a 1000 r.p.m. como valor efectivo sinusoidal entre dos bornes.

#### Momento de inercia del rotor $J$ [kgcm<sup>2</sup>]

La constante J es una medida de la capacidad de aceleración del motor. Con  $I_0$  resulta, por ejemplo, un tiempo de aceleración  $t_b$  de 0 hasta  $3000 \text{ min}^{-1}$  :

$$t_b [\text{s}] = \frac{3000 \times 2\pi}{M_0 \times 60\text{s}} \times \frac{m^2}{10^4 \times \text{cm}^2} \times J \quad \text{con } M_0 \text{ en Nm y } J \text{ en kgcm}^2$$

#### Constante térmica de tiempo $t_{th}$ [min]

La constante  $t_{th}$  indica el tiempo de calentamiento del motor frío bajo carga con  $I_0$  hasta alcanzar  $0,63 \times 105$  Kelvin de sobretemperatura.

Bajo carga con corriente máxima, el calentamiento tiene lugar en un tiempo mucho menor.

#### Tiempos de respuesta del freno $t_{BRH}$ [ms] / $t_{BRL}$ [ms]

Las constantes indican los tiempos de reacción del freno de detención en funcionamiento con tensión nominal en el servoamplificador.

#### $U_N$

Tensión nominal del red

#### $U_n$

Tensión nominal del circuito intermedio  $U_n = \sqrt{2} * U_N$



Esta página se ha dejado en blanco intencionadamente.

## 41 Technical Data

### 41.1 Dictionary for technical data tables

English	Deutsch	Italiano	Español
Data	Daten	Dati	Datos
Symbol [Unit]	Symbol [Einheit]	Simbolo [unità]	Símbolo [unidad]
Electrical data	Elektrische Daten	Dati elettrici	Datos eléctricos
Standstill torque	Stillstands Drehmoment	Coppia cont. allo stallo	Par motor de parada
Standstill current	Stillstandsstrom	Corrente cont. allo stallo	Corriente de parada
max. Mains voltage	max. Netz-Nennspannung	Tensione di rete nom. max.	Tensión max del red
Rated speed	Nenn Drehzahl	Velocità nominale	Velocidad nominal
Rated torque	Nenn Drehmoment	Coppia nominale	Par motor nominal
Rated power	Nennleistung	Potenza nominale	Potencia nominal
Peak current	Spitzenstrom	Corrente di picco	Corriente máxima
Peak torque	Spitzen Drehmoment	Coppia di picco	Par motor motor máximo
Torque constant	Drehmomentkonstante	Costante di coppia	Costante de par motor
Voltage constant	Spannungskonstante	Costante di tensione	Costante de tensión
Winding resistance	Wicklungswiderstand	Resistenza avvolgimento	Resistencia de la bobina
Winding inductance	Wicklungsinduktivität	Induttività avvolgimento	Inductividad de la bobina
Mechanical data	Mechanische Daten	Dati meccanici	Datos mecánicos
Rotor moment of inertia	Rotorträgheitsmoment	Momento di inerzia del rotore	Momento de inercia del rotor
Pole number	Polzahl	Numero di poli	Nº de polos
Static friction torque	Statisches Reibmoment	Momento di aderenza statica	Par estático de fricción
Thermal time constant	Thermische Zeitkonstante	Costante di tempo termica	Costante térmica de tiempo
Weight standard	Gewicht standard	Peso standard	Peso de estándar
Radial load permitted at shaft end	Zulässige Radialkraft am Wellenende	Soll. radiale ammessa sull'estr. dell'albero	Fuerza radial admitido en el extremo del eje
Axial load permitted	Zulässige Axialkraft	Soll. assiale ammessa	Fuerza axial admitido
Reference flange	Bemessungsflansch	Flangia di calcolo	Brida de la referencia
Derating in case of built-in Encoder (and Brake)	Begrenzung der Nennwerte bei eingebautem Encoder (und Bremse)	Riducendo le imposte nel caso del codificatore (e del freno) incorporati	El reducir la capacidad normal en caso de codificador (y de freno) incorporados

English	Deutsch	Italiano	Español
Brake data	Bremsendaten	Dati freno	Datos de frenos
Holding torque	Haltemoment	Coppia di arresto	Momento de parada
Operating voltage	Anschlussspannung	Tensione di allacciamento	Tensión de conexión
Electrical power	Elektrische Leistung	Potenza elettrica	Potencia eléctrica
Moment of inertia	Trägheitsmoment	Momento d'inerzia	Momento de inercia
Release delay time	Lüftverzögerungszeit	Ritardo al rilascio	Tiempo de respuesta
Application delay time	Einfallverzögerungszeit	Ritardo all'incidenza	Tiempo de reacción
Weight of the brake	Gewicht der Bremse	Peso del freno	Peso de freno
Typical backlash	typisches Spiel	Gioco tipico	Contragolpe típico

English	Deutsch	Italiano	Español
Connections and cables	Anschlüsse und Leitungen	Collegamenti e cavi	Conexiones y conductores
Power connection	Leistungsanschluss	Collegamento potenza	Conexión de potencia
Motor cable, shielded	Motorleitung, geschirmt	Cavo motore, schermato	Cable del motor, protegido
Motor cable with control leads, shielded	Motorleitung mit Steueradern, geschirmt	Cavo motore con fili di comando, schermato	Cable del motor con conductores de control, protegido
Resolver connection	Resolveranschluss	Collegamento resolver	Conexión del resolver
Resolver cable, shielded	Resolverleitung, geschirmt	Cavo resolver, schermato	Cable del resolver, protegido
Encoder connection	Encoderanschluss	Collegamento Encoder	Conexión del Codificador
Encoder cable, shielded	Encoderleitung, geschirmt	Cavo Encoder, schermato	Cable del codificador, protegido
poles, round, angular	polig, rund, abgewinkelt	poli, rotondo, piegato	polos, redondo, en ángulo
Terminal box	Klemmkasten	Scatola die serrage	Caja de sujeción

## 41.2 Technical Data AKM1

Data	Symbol [Unit]	AKM							
		11B	11C	11E	12C	12E	13C	13D	
<b>Electrical data</b>									
Standstill torque*	$M_0$ [Nm]**	0,18	0,18	0,18	0,31	0,31	0,41	0,40	
Standstill current	$I_{0rms}$ [A]**	1,16	1,45	2,91	1,51	2,72	1,48	2,40	
max. Mains voltage	$U_N$ [VAC]	230VAC							
$U = 75VDC$	Rated speed	$n_n$ [min <sup>-1</sup> ]	—	—	6000	—	3000	—	2000
	Rated torque*	$M_n$ [Nm]	—	—	0,18	—	0,31	—	0,40
	Rated power	$P_n$ [kW]	—	—	0,11	—	0,10	—	0,08
$U_N = 115V$	Rated speed	$n_n$ [min <sup>-1</sup> ]	4000	6000	—	4000	8000	3000	7000
	Rated torque*	$M_n$ [Nm]	0,18	0,18	—	0,30	0,28	0,41	0,36
	Rated power	$P_n$ [kW]	0,08	0,11	—	0,13	0,23	0,13	0,27
$U_N = 230V$	Rated speed	$n_n$ [min <sup>-1</sup> ]	8000	—	—	8000	—	8000	—
	Rated torque*	$M_n$ [Nm]	0,17	—	—	0,28	—	0,36	—
	Rated power	$P_n$ [kW]	0,14	—	—	0,23	—	0,30	—
$U_N = 400V$	Rated speed	$n_n$ [min <sup>-1</sup> ]	—	—	—	—	—	—	—
	Rated torque*	$M_n$ [Nm]	—	—	—	—	—	—	—
	Rated power	$P_n$ [kW]	—	—	—	—	—	—	—
$U_N = 480V$	Rated speed	$n_n$ [min <sup>-1</sup> ]	—	—	—	—	—	—	—
	Rated torque*	$M_n$ [Nm]	—	—	—	—	—	—	—
	Rated power	$P_n$ [kW]	—	—	—	—	—	—	—
Peak current	$I_{0max}$ [A]	5,8	7,3	14,6	7,6	13,6	7,4	12	
Peak torque	$M_{0max}$ [Nm]	0,71	0,71	0,71	1,27	1,24	1,73	1,72	
Torque constant	$K_{Trms}$ [Nm/A]	0,16	0,13	0,06	0,21	0,11	0,28	0,17	
Voltage constant	$K_{Erms}$ [mV/min]	10,2	8,3	4,1	13,3	7,2	17,9	10,9	
Winding resistance Ph-Ph	$R_{25}$ [Ω]	18,2	12,1	3,1	12,4	3,9	13,5	5,4	
Winding inductance Ph-Ph	$L$ [mH]	12,5	8,3	2,0	9,1	2,7	10,3	3,8	
<b>Mechanical data</b>									
Rotor moment of inertia	$J$ [kgcm <sup>2</sup> ]	0,017		0,031		0,045			
Pole number		6		6		6			
Static friction torque	$M_R$ [Nm]	0,0011		0,0021		0,0031			
Thermal time constant	$t_{TH}$ [min]	4		6		7			
Weight standard	$G$ [kg]	0,35		0,49		0,63			
Radial load permitted	$F_R$ [N]	see p.87							
Axial load permitted	$F_A$ [N]	see p.87							

\* Reference flange Aluminium 254mm \* 254mm \* 6,35mm

\*\* Derating in case of built-in Encoder 5%

## Connections and cables

Power connection	4 + 4 poles, round, on cable 0.5m
Motorcable, shielded	4 x 1
Motor cable with control leads, shielded	4 x 1 + 2 x 0.75
Resolver connection	12 poles, round, on cable 0.5m
Resolver cable, shielded	4 x 2 x 0.25mm <sup>2</sup>
Comcoder connection (option)	17 poles, round, on cable 0.5m

41.3 Technical Data AKM2

Data	Symbol [Unit]	AKM												
		21C	21E	21G	22C	22E	22G	23C	23D	23F	24C	24D	24F	
<b>Electrical data</b>														
Standstill torque*	$M_0$ [Nm]**	0,48	0,50	0,50	0,84	0,87	0,88	1,13	1,16	1,18	1,38	1,41	1,42	
Standstill current	$I_{0rms}$ [A]**	1,58	3,11	4,87	1,39	2,73	4,82	1,41	2,19	4,31	1,42	2,21	3,89	
max. Mains voltage	$U_N$ [VAC]	480												
$U = 75VDC$	Rated speed	$n_n$ [min <sup>-1</sup> ]	—	2000	4000	—	1000	2500	—	—	1500	—	—	1000
	Rated torque*	$M_n$ [Nm]	—	0,48	0,46	—	0,85	0,83	—	—	1,15	—	—	1,39
	Rated power	$P_n$ [kW]	—	0,10	0,19	—	0,09	0,22	—	—	0,18	—	—	0,15
$U_N = 115V$	Rated speed	$n_n$ [min <sup>-1</sup> ]	2500	7000	—	1000	3500	7000	1000	1500	4500	—	1500	3000
	Rated torque*	$M_n$ [Nm]	0,46	0,41	—	0,83	0,81	0,74	1,11	1,12	1,07	—	1,36	1,33
	Rated power	$P_n$ [kW]	0,12	0,30	—	0,09	0,30	0,54	0,12	0,18	0,50	—	0,21	0,42
$U_N = 230V$	Rated speed	$n_n$ [min <sup>-1</sup> ]	8000	—	—	3500	8000	—	2500	5000	8000	2000	4000	8000
	Rated torque*	$M_n$ [Nm]	0,39	—	—	0,78	0,70	—	1,08	1,03	0,94	1,32	1,29	1,12
	Rated power	$P_n$ [kW]	0,32	—	—	0,29	0,59	—	0,28	0,54	0,79	0,28	0,54	0,94
$U_N = 400V$	Rated speed	$n_n$ [min <sup>-1</sup> ]	—	—	—	8000	—	—	5500	8000	—	4500	8000	—
	Rated torque*	$M_n$ [Nm]	—	—	—	0,68	—	—	0,99	0,92	—	1,25	1,11	—
	Rated power	$P_n$ [kW]	—	—	—	0,57	—	—	0,57	0,77	—	0,59	0,93	—
$U_N = 480V$	Rated speed	$n_n$ [min <sup>-1</sup> ]	—	—	—	8000	—	—	7000	8000	—	5500	8000	—
	Rated torque*	$M_n$ [Nm]	—	—	—	0,68	—	—	0,95	0,92	—	1,22	1,11	—
	Rated power	$P_n$ [kW]	—	—	—	0,57	—	—	0,70	0,77	—	0,70	0,93	—
Peak current	$I_{0max}$ [A]	7,9	15,6	24,4	7	13,7	24,1	7,1	11	21,6	7,1	11,1	19,5	
Peak torque	$M_{0max}$ [Nm]	1,65	1,67	1,68	3,11	3,15	3,17	4,4	4,43	4,49	5,51	5,58	5,61	
Torque constant	$K_{Trms}$ [Nm/A]	0,30	0,16	0,10	0,61	0,32	0,18	0,80	0,52	0,27	0,97	0,63	0,36	
Voltage constant	$K_{Erms}$ [mVmin]	19,5	10,2	6,6	39	20,4	11,7	51,8	33,8	17,6	62,4	40,8	23,4	
Winding resistance Ph-Ph	$R_{25}$ [Ω]	13,0	3,42	1,44	20	5,22	1,69	21,2	8,77	2,34	20,4	9,02	2,77	
Winding inductance Ph-Ph	$L$ [mH]	19	5,2	2,18	35,5	9,7	3,19	40,7	17,3	4,68	43,8	18,7	6,16	
<b>Mechanical data</b>														
Rotor moment of inertia	$J$ [kgcm <sup>2</sup> ]	0,11			0,16			0,22			0,27			
Pole number		6			6			6			6			
Static friction torque	$M_R$ [Nm]	0,002			0,005			0,007			0,01			
Thermal time constant	$t_{TH}$ [min]	8			9			10			11			
Weight standard	$G$ [kg]	0,82			1,1			1,38			1,66			
Radial load permitted	$F_R$ [N]	see p.88												
Axial load permitted	$F_A$ [N]	see p.88												

\* reference flange Aluminium 254mm \* 254mm \* 6,35mm

\*\* Derating in case of built-in Encoder 5%, with built-in Encoder and Brake 9%

**Brake data**

Holding torque @ 120°C	$M_{BR}$ [Nm]	1,42	Release delay time	$t_{BRH}$ [ms]	20
Operating voltage	$U_{BR}$ [VDC]	24 ± 10 %	Application delay time	$t_{BRL}$ [ms]	18
Electrical power	$P_{BR}$ [W]	8,4	Weight of the brake	$G_{BR}$ [kg]	0,27
Moment of inertia	$J_{BR}$ [kgcm <sup>2</sup> ]	0,011	Typical backlash	[ °mech.]	0,46

**Connections and cables**

Power connection	4 + 4 poles, round, angular
Motorcable, shielded	4 x 1
Motor cable with control leads, shielded	4 x 1 + 2 x 0.75
Resolver connection	12 poles, round, angular
Resolver cable, shielded	4 x 2 x 0.25mm <sup>2</sup>
Encoder connection (option)	17 poles, round, angular
Encoder cable, shielded	7 x 2 x 0.25mm <sup>2</sup>

## 41.4 Technical Data AKM3

Dat	Symbol [Unit]	AKM										
		31C	31E	31H	32C	32D	32E	32H	33C	33E	33H	
<b>Electrical data</b>												
	Standstill torque*	$M_0$ [Nm]**	1,15	1,20	1,23	2,00	2,04	2,04	2,10	2,71	2,79	2,88
	Standstill current	$I_{0rms}$ [A]**	1,37	2,99	5,85	1,44	2,23	2,82	5,50	1,47	2,58	5,62
	max. Mains voltage	$U_N$ [VAC]	480									
U = 75VDC	Rated speed	$n_n$ [min <sup>-1</sup> ]	—	750	2000	—	—	—	1200	—	—	800
	Rated torque*	$M_n$ [Nm]	—	1,19	1,20	—	—	—	2,06	—	—	2,82
	Rated power	$P_n$ [kW]	—	0,09	0,25	—	—	—	0,26	—	—	0,24
U <sub>N</sub> = 115V	Rated speed	$n_n$ [min <sup>-1</sup> ]	—	2500	6000	—	1000	—	3000	—	—	2500
	Rated torque*	$M_n$ [Nm]	—	1,17	0,97	—	2,00	—	1,96	—	—	2,66
	Rated power	$P_n$ [kW]	—	0,31	0,61	—	0,21	—	0,62	—	—	0,70
U <sub>N</sub> = 230V	Rated speed	$n_n$ [min <sup>-1</sup> ]	2500	6000	—	1500	2500	3500	7000	1000	2000	5500
	Rated torque*	$M_n$ [Nm]	1,12	0,95	—	1,95	1,93	1,87	1,45	2,64	2,62	2,27
	Rated power	$P_n$ [kW]	0,29	0,60	—	0,31	0,51	0,69	1,06	0,28	0,55	1,31
U <sub>N</sub> = 400V	Rated speed	$n_n$ [min <sup>-1</sup> ]	5000	—	—	3000	5500	7000	—	2000	4500	—
	Rated torque*	$M_n$ [Nm]	1,00	—	—	1,86	1,65	1,41	—	2,54	2,34	—
	Rated power	$P_n$ [kW]	0,52	—	—	0,58	0,95	1,03	—	0,53	1,10	—
U <sub>N</sub> = 480V	Rated speed	$n_n$ [min <sup>-1</sup> ]	6000	—	—	3500	6000	8000	—	2500	5000	—
	Rated torque*	$M_n$ [Nm]	0,91	—	—	1,83	1,58	1,22	—	2,50	2,27	—
	Rated power	$P_n$ [kW]	0,57	—	—	0,67	0,99	1,02	—	0,65	1,19	—
	Peak current	$I_{0max}$ [A]	6,9	15	29,3	7,2	11,2	14,1	27,5	7,4	12,9	28,1
	Peak torque	$M_{0max}$ [Nm]	4,49	4,6	4,67	8,18	8,3	8,32	8,47	11,55	11,76	12,01
	Torque constant	$K_{Trms}$ [Nm/A]	0,85	0,41	0,21	1,40	0,92	0,73	0,39	1,86	1,10	0,52
	Voltage constant	$K_{Erms}$ [mV/min]	54,5	26,1	13,7	89,8	59,0	47,1	24,8	120	70,6	33,4
	Winding resistance Ph-Ph	$R_{25}$ [Ω]	21,4	4,74	1,29	23,8	10,3	6,3	1,69	26,6	9,01	1,96
	Winding inductance Ph-Ph	L [mH]	37,5	8,6	2,4	46,5	20,1	12,8	3,55	53,6	18,5	4,1
<b>Mechanical data</b>												
	Rotor moment of inertia	J [kgcm <sup>2</sup> ]	0,33			0,59			0,85			
	Pole number		8			8			8			
	Static friction torque	$M_R$ [Nm]	0,014			0,02			0,026			
	Thermal time constant	$t_{TH}$ [min]	14			17			20			
	Weight standard	G [kg]	1,55			2,23			2,9			
	Radial load permitted	$F_R$ [N]	see p.89									
	Axial load permitted	$F_A$ [N]	see p.89									

\* Reference flange Aluminium 254mm \* 254mm \* 6.35mm

\*\* Derating in case of built-in Encoder 5%, with built-in Encoder and Brake 7%

**Brake data**

Holding torque @ 120°C	$M_{BR}$ [Nm]	2.5	Release delay time	$t_{BRH}$ [ms]	25
Operating voltage	$U_{BR}$ [VDC]	24 ± 10 %	Application delay time	$t_{BRL}$ [ms]	10
Electrical power	$P_{BR}$ [W]	10.1	Weight of the brake	$G_{BR}$ [kg]	0.35
Moment of inertia	$J_{BR}$ [kgcm <sup>2</sup> ]	0.011	Typical backlash	[ °mech.]	0.46

**Connections and cables**

Power connection	4 + 4 poles, round, angular
Motorcable, shielded	4 x 1
Motor cable with control leads, shielded	4 x 1 + 2 x 0.75
Resolver connection	12 poles, round, angular
Resolver cable, shielded	4 x 2 x 0.25mm <sup>2</sup>
Encoder connection (option)	17 poles, round, angular
Encoder cable, shielded	7 x 2 x 0.25mm <sup>2</sup>

41.5 Technical Data AKM4

Data	Symbol [Unit]	41C	41E	41H	AKM			
					42C	42E	42G	42J
<b>Electrical data</b>								
Standstill torque*	$M_0$ [Nm]**	1,95	2,02	2,06	3,35	3,42	3,53	3,56
Standstill current	$I_{0rms}$ [A]**	1,46	2,85	5,60	1,40	2,74	4,80	8,40
max. Mains voltage	$U_N$ [VAC]	480						
$U = 75VDC$	Rated speed	$n_n$ [min <sup>-1</sup> ]	—	—	1000	—	—	—
	Rated torque*	$M_n$ [Nm]	—	—	1,99	—	—	—
	Rated power	$P_n$ [kW]	—	—	0,21	—	—	—
$U_N = 115V$	Rated speed	$n_n$ [min <sup>-1</sup> ]	—	1200	3000	—	—	3000
	Rated torque*	$M_n$ [Nm]	—	1,94	1,86	—	—	3,03
	Rated power	$P_n$ [kW]	—	0,24	0,58	—	—	0,95
$U_N = 230V$	Rated speed	$n_n$ [min <sup>-1</sup> ]	1200	3000	6000	—	1800	3500
	Rated torque*	$M_n$ [Nm]	1,88	1,82	1,62	—	3,12	2,90
	Rated power	$P_n$ [kW]	0,24	0,57	1,02	—	0,59	1,06
$U_N = 400V$	Rated speed	$n_n$ [min <sup>-1</sup> ]	3000	6000	—	1500	3500	6000
	Rated torque*	$M_n$ [Nm]	1,77	1,58	—	3,10	2,81	2,35
	Rated power	$P_n$ [kW]	0,56	0,99	—	0,49	1,03	1,48
$U_N = 480V$	Rated speed	$n_n$ [min <sup>-1</sup> ]	3500	6000	—	2000	4000	6000
	Rated torque*	$M_n$ [Nm]	1,74	1,58	—	3,02	2,72	2,35
	Rated power	$P_n$ [kW]	0,64	0,99	—	0,63	1,14	1,48
Peak current	$I_{0max}$ [A]	7,3	14,3	28	7	13,7	24	42
Peak torque	$M_{0max}$ [Nm]	7,02	7,15	7,2	12,8	13	13,2	13,3
Torque constant	$K_{Trms}$ [Nm/A]	1,34	0,71	0,37	2,40	1,26	0,74	0,43
Voltage constant	$K_{Erms}$ [mVmin]	86,3	45,6	23,7	154	80,9	47,5	27,5
Winding resistance Ph-Ph	$R_{25}$ [ $\Omega$ ]	21,3	6,02	1,56	27,5	7,78	2,51	0,80
Winding inductance Ph-Ph	$L$ [mH]	66,1	18,4	5,0	97,4	26,8	9,2	3,1
<b>Mechanical data</b>								
Rotor moment of inertia	$J$ [kgcm <sup>2</sup> ]	0,81			1,5			
Pole number		10			10			
Static friction torque	$M_R$ [Nm]	0,014			0,026			
Thermal time constant	$t_{TH}$ [min]	13			17			
Weight standard	$G$ [kg]	2,44			3,39			
Radial load permitted	$F_R$ [N]	see p.90						
Axial load permitted	$F_A$ [N]	see p.90						

\* Reference flange Aluminium 254mm \* 254mm \* 6.35mm

\*\* Derating in case of built-in Encoder 6%, with built-in Encoder and Brake 12%

**Brake data**

Holding torque @ 120°C	$M_{BR}$ [Nm]	6	Release delay time	$t_{BRH}$ [ms]	35
Operating voltage	$U_{BR}$ [VDC]	24 ± 10 %	Application delay time	$t_{BRL}$ [ms]	15
Electrical power	$P_{BR}$ [W]	12.8	Weight of the brake	$G_{BR}$ [kg]	0.63
Moment of inertia	$J_{BR}$ [kgcm <sup>2</sup> ]	0.068	Typical backlash	[ ° mech.]	0.37

**Connections and cables**

Power connection	4 + 4 poles, round, angular
Motorcable, shielded	4 x 1.5
Motor cable with control leads, shielded	4 x 1.5 + 2 x 0.75
Resolver connection	12 poles, round, angular
Resolver cable, shielded	4 x 2 x 0.25mm <sup>2</sup>
Encoder connection (option)	17 poles, round, angular
Encoder cable, shielded	7 x 2 x 0.25mm <sup>2</sup>

Data	Symbol [Units]	AKM						
		43E	43G	43K	44E	44G	44J	
<b>Electrical data</b>								
Standstill torque*	$M_0$ [Nm]**	4,70	4,80	4,90	5,76	5,88	6,00	
Standstill current	$I_{0rms}$ [A]**	2,76	4,87	9,60	2,90	5,00	8,80	
max. Mains voltage	$U_N$ [VAC]	480						
U = 75VDC	Rated speed	$n_n$ [min <sup>-1</sup> ]	—	—	—	—	—	
	Rated torque*	$M_n$ [Nm]	—	—	—	—	—	
	Rated power	$P_n$ [kW]	—	—	—	—	—	
U <sub>N</sub> = 115V	Rated speed	$n_n$ [min <sup>-1</sup> ]	—	—	2500	—	—	
	Rated torque*	$M_n$ [Nm]	—	—	4,08	—	—	
	Rated power	$P_n$ [kW]	—	—	1,07	—	—	
U <sub>N</sub> = 230V	Rated speed	$n_n$ [min <sup>-1</sup> ]	1500	2500	6000	1200	2000	4000
	Rated torque*	$M_n$ [Nm]	4,24	4,00	2,62	5,22	4,90	3,84
	Rated power	$P_n$ [kW]	0,67	1,05	1,65	0,66	1,03	1,61
U <sub>N</sub> = 400V	Rated speed	$n_n$ [min <sup>-1</sup> ]	2500	5000	—	2000	4000	6000
	Rated torque*	$M_n$ [Nm]	3,92	3,01	—	4,80	3,76	2,75
	Rated power	$P_n$ [kW]	1,03	1,58	—	1,01	1,57	1,73
U <sub>N</sub> = 480V	Rated speed	$n_n$ [min <sup>-1</sup> ]	3000	6000	—	2500	5000	6000
	Rated torque*	$M_n$ [Nm]	3,76	2,57	—	4,56	3,19	2,75
	Rated power	$P_n$ [kW]	1,18	1,61	—	1,19	1,67	1,73
Peak current	$I_{0max}$ [A]	13,8	24,4	48	14,5	25	44	
Peak torque	$M_{0max}$ [Nm]	18,5	18,8	19	23,7	23,7	24	
Torque constant	$K_{Trms}$ [Nm/A]	1,72	0,99	0,52	2,04	1,19	0,69	
Voltage constant	$K_{Erms}$ [mV/min]	111	63,9	33,2	132	76,6	44,2	
Winding resistance Ph-Ph	$R_{25}$ [Ω]	8,61	2,61	0,74	8,08	2,80	0,94	
Winding inductance Ph-Ph	L [mH]	32,6	10,8	2,9	33,9	11,5	3,8	
<b>Mechanical data</b>								
Rotor moment of inertia	J [kgcm <sup>2</sup> ]	2,1			2,7			
Pole number		10			10			
Static friction torque	$M_R$ [Nm]	0,038			0,05			
Thermal time constant	$t_{TH}$ [min]	20			24			
Weight standard	G [kg]	4,35			5,3			
Radial load permitted	$F_R$ [N]	see p.90						
Axial load permitted	$F_A$ [N]	see p.90						

\* Reference flange Aluminium 254mm \* 254mm \* 6.35mm

\*\* Derating in case of built-in Encoder 6%, with built-in Encoder and Brake 12%

41.6 Technical Data AKM5

Data	Symbol [Unit]	AKM														
		51E	51G	51H	51K	52E	52G	52H	52K	52M	53G	53H	53K	53M	53P	
<b>Electrical data</b>																
Standstill torque*	$M_0$ [Nm]**	4,70	4,75	4,79	4,90	8,34	8,43	8,48	8,60	8,60	11,4	11,5	11,6	11,4	11,4	
Standstill current	$I_{0rms}$ [A]**	2,75	4,84	6	9,4	2,99	4,72	5,9	9,3	13,1	4,77	6,6	9,4	13,4	19,1	
max. Mains voltage	$U_N$ [VAC]	480														
$U_N = 75VDC$	Rated speed	$n_n$ [min <sup>-1</sup> ]	—	—	—	—	—	—	—	—	—	—	—	—	—	
	Rated torque*	$M_n$ [Nm]	—	—	—	—	—	—	—	—	—	—	—	—	—	
	Rated power	$P_n$ [kW]	—	—	—	—	—	—	—	—	—	—	—	—	—	
$U_N = 115V$	Rated speed	$n_n$ [min <sup>-1</sup> ]	—	—	—	2500	—	—	—	—	—	—	—	—	—	
	Rated torque*	$M_n$ [Nm]	—	—	—	4,15	—	—	—	—	—	—	—	—	—	
	Rated power	$P_n$ [kW]	—	—	—	1,09	—	—	—	—	—	—	—	—	—	
$U_N = 230V$	Rated speed	$n_n$ [min <sup>-1</sup> ]	1200	2500	3000	5500	—	1500	1800	3000	4500	1000	—	2000	3000	5000
	Rated torque*	$M_n$ [Nm]	4,41	4,02	3,87	2,35	—	7,69	7,53	6,80	5,20	10,7	—	10,1	8,72	5,88
	Rated power	$P_n$ [kW]	0,55	1,05	1,22	1,35	—	1,21	1,42	2,14	2,45	1,12	—	2,12	2,74	3,08
$U_N = 400V$	Rated speed	$n_n$ [min <sup>-1</sup> ]	2500	5000	6000	—	1500	2500	3500	5500	—	2000	3000	4000	—	—
	Rated torque*	$M_n$ [Nm]	3,98	2,62	1,95	—	7,61	7,06	6,26	3,90	—	9,85	8,83	7,65	—	—
	Rated power	$P_n$ [kW]	1,04	1,37	1,23	—	1,20	1,85	2,3	2,25	—	2,06	2,77	3,20	—	—
$U_N = 480V$	Rated speed	$n_n$ [min <sup>-1</sup> ]	3000	6000	6000	—	2000	3000	4000	6000	—	2400	3500	4500	—	—
	Rated torque*	$M_n$ [Nm]	3,80	1,94	1,95	—	7,28	6,66	5,77	3,25	—	9,50	8,23	6,85	—	—
	Rated power	$P_n$ [kW]	1,19	1,22	1,23	—	1,52	2,09	2,42	2,04	—	2,39	3,02	3,23	—	—
Peak current	$I_{0max}$ [A]	13,8	24,2	30	47	15	23,6	29,5	46,5	65,5	23,9	33	47	67	95,5	
Peak torque	$M_{0max}$ [Nm]	15,6	15,6	15,6	15,8	29,5	29,7	29,7	30	30	42,2	42,4	42,6	42,1	42,1	
Torque constant	$K_{Trms}$ [Nm/A]	1,72	0,99	0,8	0,52	2,79	1,79	1,44	0,93	0,66	2,39	1,75	1,24	0,85	0,60	
Voltage constant	$K_{Erms}$ [mV/min]	110	63,6	51,3	33,5	179	115	92,7	60,1	42,4	154	112	79,8	54,7	38,4	
Winding resistance Ph-Ph	$R_{25}$ [Ω]	8,98	2,87	1,97	0,75	8,96	3,70	2,35	0,96	0,49	3,97	2,1	1,06	0,51	0,28	
Winding inductance Ph-Ph	$L$ [mH]	36,6	12,1	7,9	3,40	44,7	18,5	11,9	5,00	2,50	21,3	11,4	5,70	2,70	1,30	
<b>Mechanical data</b>																
Rotor moment of inertia	$J$ [kgcm <sup>2</sup> ]	3,4			6,2			9,1								
Pole number		10			10			10								
Static friction torque	$M_R$ [Nm]	0,022			0,04			0,058								
Thermal time constant	$t_{TH}$ [min]	20			24			28								
Weight standard	$G$ [kg]	4,2			5,8			7,4								
Radial load permitted	$F_R$ [N]	see p.91														
Axial load permitted	$F_A$ [N]	see p.91														

\* Reference flange Aluminium 305mm \* 305mm \* 12.7mm

\*\* Derating in case of built-in Encoder 6%, with built-in Encoder and Brake 10%

**Brake data**

Holding torque @ 120°C	$M_{BR}$ [Nm]	14.5	Release delay time	$t_{BRH}$ [ms]	80
Operating voltage	$U_{BR}$ [VDC]	24 ± 10 %	Application delay time	$t_{BRL}$ [ms]	15
Electrical power	$P_{BR}$ [W]	19.5	Weight of the brake	$G_{BR}$ [kg]	1.1
Moment of inertia	$J_{BR}$ [kgcm <sup>2</sup> ]	0.173	Typical backlash	[ ° mech.]	0.31

**Connections and cables**

Power connection	4 + 4 poles, round, angular	
Motorcable, shielded	4 x 1.5	4 x 2.5
Motor cable with control leads, shielded	4 x 1.5 + 2 x 0.75	4 x 2.5 + 2 x 1
Resolver connection	12 poles, round, angular	
Resolver cable, shielded	4 x 2 x 0.25mm <sup>2</sup>	
Encoder connection (option)	17 poles, round, angular	
Encoder cable, shielded	7 x 2 x 0.25mm <sup>2</sup>	



Data	Symbol [Unit]	AKM					
		54G	54H	54K	54L	54N	
<b>Electrical data</b>							
Standstill torque*	$M_0$ [Nm]	14,3	14,2	14,4	14,1	14,1	
Standstill current	$I_{0rms}$ [A]	5,0	5,5	9,7	12,5	17,8	
max. Mains voltage	$U_N$ [VAC]	480					
U = 75VDC	Rated speed	$n_n$ [min <sup>-1</sup> ]	—	—	—	—	
	Rated torque*	$M_n$ [Nm]	—	—	—	—	
	Rated power	$P_n$ [kW]	—	—	—	—	
U <sub>N</sub> = 115V	Rated speed	$n_n$ [min <sup>-1</sup> ]	—	—	—	—	
	Rated torque*	$M_n$ [Nm]	—	—	—	—	
	Rated power	$P_n$ [kW]	—	—	—	—	
U <sub>N</sub> = 230V	Rated speed	$n_n$ [min <sup>-1</sup> ]	—	—	1800	2500	3500
	Rated torque*	$M_n$ [Nm]	—	—	12,7	11,5	9,85
	Rated power	$P_n$ [kW]	—	—	2,39	3,00	3,61
U <sub>N</sub> = 400V	Rated speed	$n_n$ [min <sup>-1</sup> ]	1500	1500	3500	4500	—
	Rated torque*	$M_n$ [Nm]	12,9	12,6	10,0	8,13	—
	Rated power	$P_n$ [kW]	2,03	2,38	3,68	3,83	—
U <sub>N</sub> = 480V	Rated speed	$n_n$ [min <sup>-1</sup> ]	2000	2000	4000	—	—
	Rated torque*	$M_n$ [Nm]	12,3	12,2	9,25	—	—
	Rated power	$P_n$ [kW]	2,57	2,56	3,87	—	—
Peak current	$I_{0max}$ [A]	25	27,5	48,5	62,5	89	
Peak torque	$M_{0max}$ [Nm]	54,4	53,9	54,8	53,9	54	
Torque constant	$K_{Trms}$ [Nm/A]	2,88	2,57	1,50	1,13	0,80	
Voltage constant	$K_{Erms}$ [mV/min]	185	166	96,6	72,9	51,3	
Winding resistance Ph-Ph	$R_{25}$ [Ω]	4,08	3,2	1,08	0,65	0,33	
Winding inductance Ph-Ph	L [mH]	22,9	18,3	6,20	3,50	1,80	
<b>Mechanical data</b>							
Rotor moment of inertia	J [kgcm <sup>2</sup> ]	12					
Pole number		10					
Static friction torque	$M_R$ [Nm]	0,077					
Thermal time constant	$t_{TH}$ [min]	31					
Weight standard	G [kg]	9					
Radial load permitted	$F_R$ [N]	see p.91					
Axial load permitted	$F_A$ [N]	see p.91					

\* Reference flange Aluminium 305mm \* 305mm \* 12.7mm

\*\* Derating in case of built-in Encoder 6%, with built-in Encoder and Brake 10%

41.7 Technical Data AKM6

Data	Symbol [Unit]	AKM								
		62G	62K	62M	62P	63G	63K	63M	63N	
<b>Electrical data</b>										
Standstill torque*	$M_0$ [Nm]**	11,9	12,2	12,2	12,3	16,5	16,8	17,0	17,0	
Standstill current	$I_{0rms}$ [A]**	4,9	9,6	13,4	18,8	4,5	9,9	13,8	17,4	
max. Mains voltage	$U_N$ [VAC]	480								
$U = 75VDC$	Rated speed	$n_n$ [min <sup>-1</sup> ]	—	—	—	—	—	—	—	
	Rated torque*	$M_n$ [Nm]	—	—	—	—	—	—	—	
	Rated power	$P_n$ [kW]	—	—	—	—	—	—	—	
$U_N = 115V$	Rated speed	$n_n$ [min <sup>-1</sup> ]	—	—	—	—	—	—	—	
	Rated torque*	$M_n$ [Nm]	—	—	—	—	—	—	—	
	Rated power	$P_n$ [kW]	—	—	—	—	—	—	—	
$U_N = 230V$	Rated speed	$n_n$ [min <sup>-1</sup> ]	—	2000	3000	4500	—	1500	2000	3000
	Rated torque*	$M_n$ [Nm]	—	10,4	9,50	8,10	—	14,9	14,3	13,0
	Rated power	$P_n$ [kW]	—	2,18	2,98	3,82	—	2,34	2,99	4,08
$U_N = 400V$	Rated speed	$n_n$ [min <sup>-1</sup> ]	1800	3500	6000	—	1200	3000	4000	5000
	Rated torque*	$M_n$ [Nm]	10,4	9,00	5,70	—	14,9	12,9	11,3	9,60
	Rated power	$P_n$ [kW]	1,96	3,30	3,58	—	1,87	4,05	4,73	5,03
$U_N = 480V$	Rated speed	$n_n$ [min <sup>-1</sup> ]	2000	4500	6000	—	1500	3500	4500	6000
	Rated torque*	$M_n$ [Nm]	10,2	8,00	5,70	—	14,6	12,0	10,5	7,00
	Rated power	$P_n$ [kW]	2,14	3,77	3,58	—	2,29	4,40	4,95	4,40
Peak current	$I_{0max}$ [A]	24,5	48	67	94,5	22,5	49,5	69	87	
Peak torque	$M_{0max}$ [Nm]	40,9	41,2	41,2	41,4	58,9	59,4	59,8	59,8	
Torque constant	$K_{Trms}$ [Nm/A]	2,47	1,28	0,91	0,66	3,70	1,71	1,24	0,98	
Voltage constant	$K_{E rms}$ [mV/min]	159	82,1	58,8	42,2	238	110	79,9	63,3	
Winding resistance Ph-Ph	$R_{25}$ [Ω]	4,13	1,08	0,57	0,30	5,50	1,14	0,61	0,39	
Winding inductance Ph-Ph	L [mH]	31,7	8,5	4,4	2,2	43,5	9,3	4,9	3,1	
<b>Mechanical data</b>										
Rotor moment of inertia	J [kgcm <sup>2</sup> ]	17				24				
Pole number		10				10				
Static friction torque	$M_R$ [Nm]	0,05				0,1				
Thermal time constant	$t_{TH}$ [min]	20				25				
Weight standard	G [kg]	8,9				11,1				
Radial load permitted	$F_R$ [N]	see p.92								
Axial load permitted	$F_A$ [N]	see p.92								

\* Reference flange Aluminium 457mm \* 457mm \* 12.7mm

\*\* Derating in case of built-in Encoder 8%, with built-in Encoder and Brake 16%

**Brake data**

Holding torque @ 120°C	$M_{BR}$ [Nm]	25	Release delay time	$t_{BRH}$ [ms]	105
Operating voltage	$U_{BR}$ [VDC]	24 ± 10 %	Application delay time	$t_{BRL}$ [ms]	20
Electrical power	$P_{BR}$ [W]	25.7	Weight of the brake	$G_{BR}$ [kg]	2
Moment of inertia	$J_{BR}$ [kgcm <sup>2</sup> ]	0.61	Typical backlash	[ ° mech.]	0.24

**Connections and cables**

Power connection	4 + 4 poles, round, angular
Motorcable, shielded	4 x 2.5
Motor cable with control leads, shielded	4 x 2.5 + 2 x 1
Resolver connection	12 poles, round, angular
Resolver cable, shielded	4 x 2 x 0.25mm <sup>2</sup>
Encoder connection (option)	17 poles, round, angular
Encoder cable, shielded	7 x 2 x 0.25mm <sup>2</sup>

Data	Symbol [Unit]	AKM									
		64K	64L	64P	64Q	65K	65M	65N	65P		
<b>Electrical data</b>											
	Standstill torque*	$M_0$ [Nm]**	20,8	21,0	20,4	20	24,8	25,0	24,3	24,5	
	Standstill current	$I_{0rms}$ [A]**	9,2	12,8	18,6	20,7	9,8	13,6	17,8	19,8	
	max. Mains voltage	$U_N$ [VAC]	480								
U = 75VDC	Rated speed	$n_n$ [min <sup>-1</sup> ]	—	—	—	—	—	—	—	—	
	Rated torque*	$M_n$ [Nm]	—	—	—	—	—	—	—	—	
	Rated power	$P_n$ [kW]	—	—	—	—	—	—	—	—	
U <sub>N</sub> = 115V	Rated speed	$n_n$ [min <sup>-1</sup> ]	—	—	—	—	—	—	—	—	
	Rated torque*	$M_n$ [Nm]	—	—	—	—	—	—	—	—	
	Rated power	$P_n$ [kW]	—	—	—	—	—	—	—	—	
U <sub>N</sub> = 230V	Rated speed	$n_n$ [min <sup>-1</sup> ]	1200	1500	2500	3000	1000	1500	2000	2400	
	Rated torque*	$M_n$ [Nm]	18,8	18,4	16,0	15,3	22,8	21,9	19,8	19,1	
	Rated power	$P_n$ [kW]	2,36	2,89	4,19	4,81	2,39	3,44	4,15	4,8	
U <sub>N</sub> = 400V	Rated speed	$n_n$ [min <sup>-1</sup> ]	2000	3000	4500	5000	2000	2500	3500	4000	
	Rated torque*	$M_n$ [Nm]	17,2	15,6	11,9	10,7	20,2	19,2	16,0	14,9	
	Rated power	$P_n$ [kW]	3,60	4,90	5,62	6,45	4,23	5,03	5,86	6,24	
U <sub>N</sub> = 480V	Rated speed	$n_n$ [min <sup>-1</sup> ]	2500	3500	5500	6000	2200	3000	4000	5000	
	Rated torque*	$M_n$ [Nm]	16,3	14,4	9,00	7,4	19,7	18,1	14,7	11,6	
	Rated power	$P_n$ [kW]	4,27	5,28	5,18	4,65	4,54	5,69	6,16	6,08	
	Peak current	$I_{0max}$ [A]	46	64	93	103,7	49	68	89	99	
	Peak torque	$M_{0max}$ [Nm]	76,1	76,6	75,2	75,7	92,4	93	91,6	92	
	Torque constant	$K_{Trms}$ [Nm/A]	2,28	1,66	1,10	1	2,54	1,85	1,38	1,3	
	Voltage constant	$K_{Erms}$ [mV/min]	147	107	71,0	64,4	164	119	88,8	80,5	
	Winding resistance Ph-Ph	$R_{25}$ [Ω]	1,41	0,75	0,36	0,32	1,35	0,73	0,43	0,37	
	Winding inductance Ph-Ph	L [mH]	11,8	6,2	2,8	2,3	11,4	6,1	3,4	2,8	
<b>Mechanical data</b>											
	Rotor moment of inertia	J [kgcm <sup>2</sup> ]	32				40				
	Pole number		10				10				
	Static friction torque	$M_R$ [Nm]	0,15				0,2				
	Thermal time constant	$t_{TH}$ [min]	30				35				
	Weight standard	G [kg]	13,3				15,4				
	Radial load permitted	$F_R$ [N]							see p.92		
	Axial load permitted	$F_A$ [N]							see p.92		

\* Reference flange Aluminium 457mm \* 457mm \* 12.7mm

\*\* Derating in case of built-in Encoder 8%, with built-in Encoder and Brake 16%

41.8 Technical Data AKM7

Data	Symbol [Unit]	AKM										
		72K	72M	72P	72Q	73M	73P	73Q	74L	74P	74Q	
<b>Electrical data</b>												
Standstill torque*	$M_0$ [Nm]**	29,7	30,0	29,4	29,5	42,0	41,6	41,5	53,0	52,5	52,2	
Standstill current	$I_{0rms}$ [A]**	9,3	13,0	18,7	23,5	13,6	19,5	24,5	12,9	18,5	26,1	
max. Mains voltage	$U_N$ [VAC]	480										
$U = 75VDC$	Rated speed	$n_n$ [min <sup>-1</sup> ]	—	—	—	—	—	—	—	—	—	
	Rated torque*	$M_n$ [Nm]	—	—	—	—	—	—	—	—	—	
	Rated power	$P_n$ [kW]	—	—	—	—	—	—	—	—	—	
$U_N = 115V$	Rated speed	$n_n$ [min <sup>-1</sup> ]	—	—	—	—	—	—	—	—	—	
	Rated torque*	$M_n$ [Nm]	—	—	—	—	—	—	—	—	—	
	Rated power	$P_n$ [kW]	—	—	—	—	—	—	—	—	—	
$U_N = 230V$	Rated speed	$n_n$ [min <sup>-1</sup> ]	—	—	1800	2000	—	1300	1500	—	—	1300
	Rated torque*	$M_n$ [Nm]	—	—	23,8	23,2	—	34,7	33,4	—	—	41,9
	Rated power	$P_n$ [kW]	—	—	4,49	4,89	—	4,72	5,25	—	—	5,71
$U_N = 400V$	Rated speed	$n_n$ [min <sup>-1</sup> ]	1500	2000	3000	4000	1500	2400	3000	1200	1800	2500
	Rated torque*	$M_n$ [Nm]	25,1	23,6	20,1	16,3	33,8	28,5	25,2	43,5	39,6	31,5
	Rated power	$P_n$ [kW]	3,94	4,94	6,31	6,83	5,31	7,16	7,92	5,47	7,46	8,25
$U_N = 480V$	Rated speed	$n_n$ [min <sup>-1</sup> ]	1800	2500	3500	4500	1800	2800	3500	1400	2000	3000
	Rated torque*	$M_n$ [Nm]	24,0	22,1	18,2	14,1	32,1	26,3	22	41,5	35,9	27,3
	Rated power	$P_n$ [kW]	4,52	5,79	6,67	6,65	6,05	7,71	8,07	6,08	7,52	8,58
Peak current	$I_{0max}$ [A]	46,5	65	93,5	117,5	68	97,5	122,6	64,5	92,5	130,5	
Peak torque	$M_{0max}$ [Nm]	118,8	119,3	117,6	117,5	169,8	168	168	217,6	215,3	214,3	
Torque constant	$K_{Trms}$ [Nm/A]	3,23	2,33	1,58	1,3	3,10	2,13	1,7	4,14	2,84	2	
Voltage constant	$K_{Erms}$ [mVmin]	208	150	102	81,2	200	137	109	266	183	129	
Winding resistance Ph-Ph	$R_{25}$ [ $\Omega$ ]	1,36	0,69	0,35	0,26	0,76	0,38	0,27	0,93	0,47	0,26	
Winding inductance Ph-Ph	$L$ [mH]	20,7	10,8	5,0	3,2	12,4	5,9	3,7	16,4	7,7	3,8	
<b>Mechanical data</b>												
Rotor moment of inertia	$J$ [kgcm <sup>2</sup> ]	65				92			120			
Pole number		10				10			10			
Static friction torque	$M_R$ [Nm]	0,16				0,24			0,33			
Thermal time constant	$t_{TH}$ [min]	46				53			60			
Weight standard	$G$ [kg]	19,7				26,7			33,6			
Radial load permitted	$F_R$ [N]	see p.93										
Axial load permitted	$F_A$ [N]	see p.93										

\* Reference flange Aluminium 457mm \* 457mm \* 12.7mm

\*\* Derating in case of built-in Encoder 7%, with built-in Encoder and Brake 13%

**Brake data**

Holding torque @ 120°C	$M_{BR}$ [Nm]	53	Release delay time	$t_{BRH}$ [ms]	110
Operating voltage	$U_{BR}$ [VDC]	24 ± 10 %	Application delay time	$t_{BRL}$ [ms]	35
Electrical power	$P_{BR}$ [W]	35.6	Weight of the brake	$G_{BR}$ [kg]	2.1
Moment of inertia	$J_{BR}$ [kgcm <sup>2</sup> ]	1.64	Typical backlash	[ °mech.]	0.2

**Connections and cables**

Power connection	4 + 4 poles, round, angular (Type H for AKM74Q)
Motorcable, shielded	4 x 2.5
Motor cable with control leads, shielded	4 x 2.5 + 2 x 1
Resolver connection	12 poles, round, angular
Resolver cable, shielded	4 x 2 x 0.25mm <sup>2</sup>
Encoder connection (option)	17-polig, rund
Encoder cable, shielded	7 x 2 x 0.25mm <sup>2</sup>

## 41.9 Technical Data AKM8

Data	Symbol [Unit]	AKM			
		82T	83T	84T	
<b>Electrical data</b>					
Standstill torque*	$M_0$ [Nm]**	75	130	180	
Standstill current	$I_{0rms}$ [A]	48	62	67	
max. Mains voltage	$U_N$ [VAC]	480			
U = 75VDC	Rated speed	$n_n$ [min <sup>-1</sup> ]	—	—	—
	Rated torque*	$M_n$ [Nm]	—	—	—
	Rated power	$P_n$ [kW]	—	—	—
U <sub>N</sub> = 115V	Rated speed	$n_n$ [min <sup>-1</sup> ]	—	—	—
	Rated torque*	$M_n$ [Nm]	—	—	—
	Rated power	$P_n$ [kW]	—	—	—
U <sub>N</sub> = 230V	Rated speed	$n_n$ [min <sup>-1</sup> ]	—	—	—
	Rated torque*	$M_n$ [Nm]	—	—	—
	Rated power	$P_n$ [kW]	—	—	—
U <sub>N</sub> = 400V	Rated speed	$n_n$ [min <sup>-1</sup> ]	2500	2200	1800
	Rated torque*	$M_n$ [Nm]	47,5	70	105
	Rated power	$P_n$ [kW]	12,4	16,1	19,8
U <sub>N</sub> = 480V	Rated speed	$n_n$ [min <sup>-1</sup> ]	3000	2500	2000
	Rated torque*	$M_n$ [Nm]	38	60	93
	Rated power	$P_n$ [kW]	11,9	15,7	19,5
	Peak current	$I_{0max}$ [A]	240	310	335
	Peak torque	$M_{0max}$ [Nm]	210	456	668
	Torque constant	$K_{Trms}$ [Nm/A]	1,6	2,1	2,7
	Voltage constant	$K_{Erms}$ [mV/min]	108	140	177
	Winding resistance Ph-Ph	$R_{25}$ [Ω]	0,092	0,061	0,058
	Winding inductance Ph-Ph	L [mH]	2,73	2,36	2,5
<b>Mechanische Daten</b>					
	Rotor moment of inertia	J [kgcm <sup>2</sup> ]	172	334	495
	Pole number		10		
	Static friction torque	$M_R$ [Nm]	1,7	1,83	2,34
	Thermal time constant	$t_{TH}$ [min]	71	94	116
	Weight standard	G [kg]	49	73	97
	Radial load permitted	$F_R$ [N]	see p.96		
	Axial load permitted	$F_A$ [N]	see p.96		

\* Reference flange Aluminium 457mm \* 457mm \* 12,7mm

\*\* Derating of standstill torque in case of built-in brake 6Nm

Derating of standstill torque in case of built-in encoder in process

**Brake data**

Holding torque @ 120°C	$M_{BR}$ [Nm]	150	Release delay time	$t_{BRH}$ [ms]	300
Operating voltage	$U_{BR}$ [VDC]	24 ± 10 %	Application delay time	$t_{BRL}$ [ms]	500
Electrical power	$P_{BR}$ [W]	49	Weight of the brake	$G_{BR}$ [kg]	9
Moment of inertia	$J_{BR}$ [kgcm <sup>2</sup> ]	5,53	Typical backlash	[ °mech.]	0,2

**Connections and cables**

Power connection	Terminal box
Motorcable, shielded	4 x 16 mm <sup>2</sup>
Motor cable with control leads, shielded	4 x 16 + 2 x 1 mm <sup>2</sup>
Resolver connection	12 poles, round, angular
Resolver cable, shielded	4 x 2 x 0.25mm <sup>2</sup>
Encoder connection (option)	17-poles, round
Encoder cable, shielded	7 x 2 x 0.25mm <sup>2</sup>

This page has been deliberately left blank.

## 42 Dimension drawings

### 42.1 Dimensions/Radial Forces AKM1

Prinzipdarstellung / drawing in principle /  
 schema elementare / representación esquemática

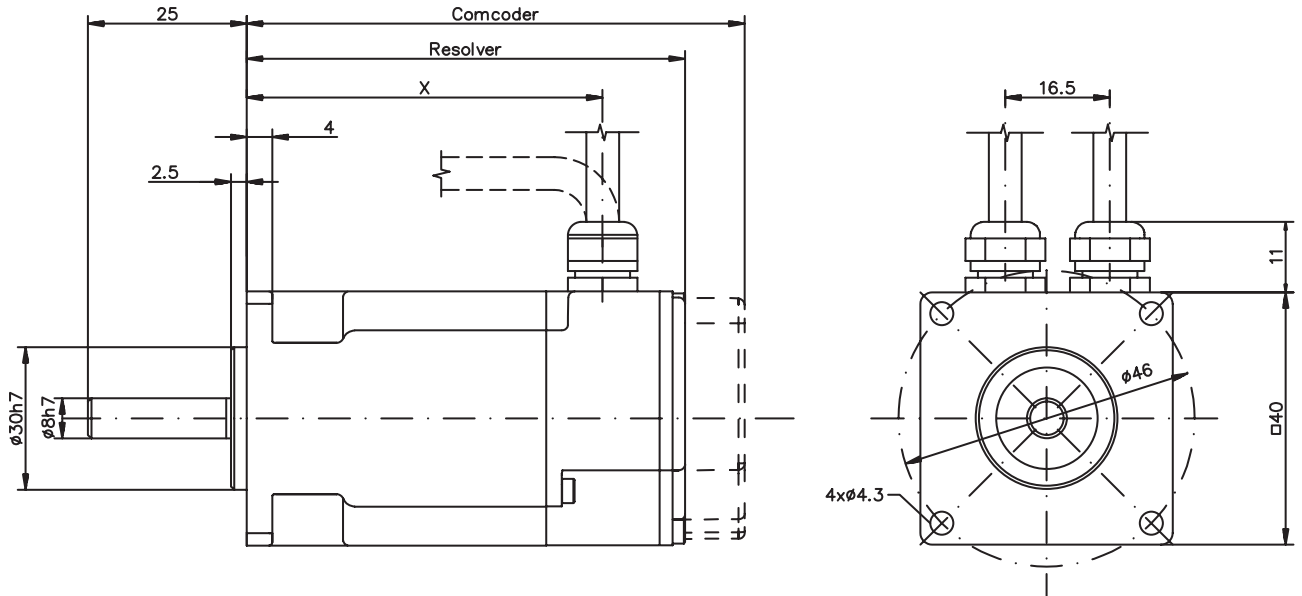

Model	X	Resolver	Comcoder
AKM11	56.1	69.6	79.0
AKM12	75.1	88.6	98.0
AKM13	94.1	107.6	117.0

Option Keyway

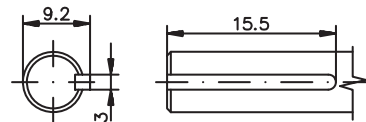

Radialkräfte am Wellenende / Radial Force at shaft end  
 Forze radiali sull'estremità dell'albero/ Fuerza radial el extremo del eje

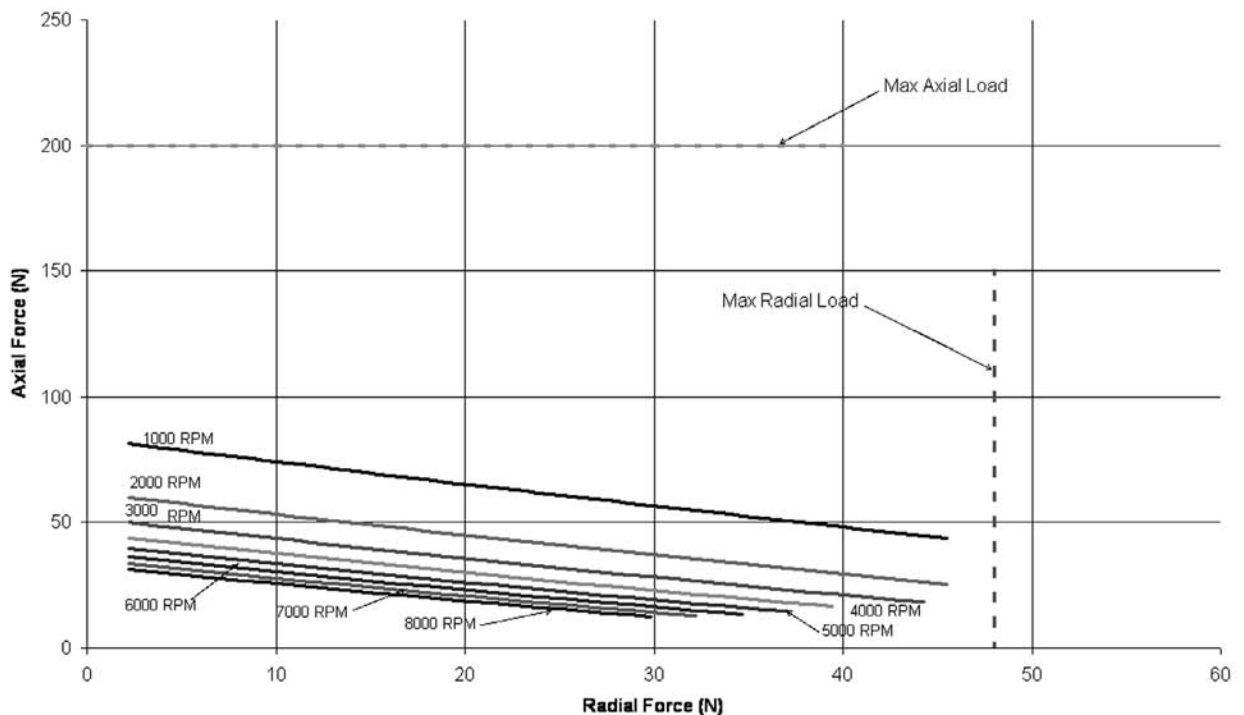

42.2 Dimensions/Radial Forces AKM2

Prinzipdarstellung / drawing in principle /  
 schema elementare / representación esquemática

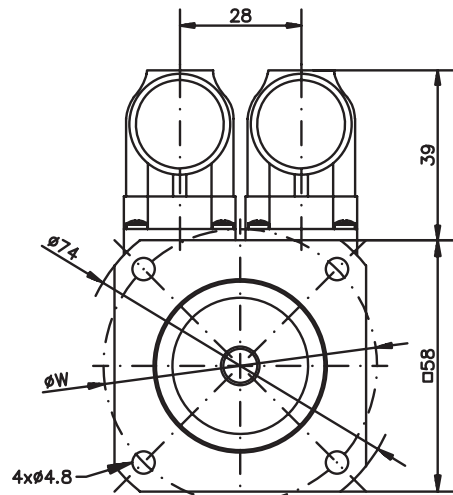
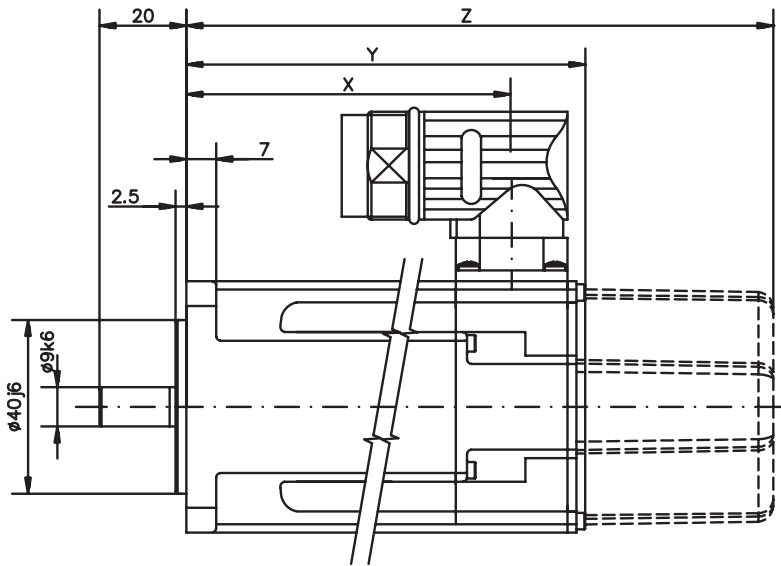

$\phi W = \phi 63\text{mm}$ , AKM2xx-Ax  
 $\phi W = \phi 65\text{mm}$ , AKM2xx-Dx

Model	X	Res/SFD/Biss/EnDat			Hiperface	
		Y	Z (brake)		Y	Z (brake)
AKM21	76.1	95.4	129.5	113.4	147.1	
AKM22	95.1	114.4	148.5	132.4	166.1	
AKM23	114.1	133.4	167.5	151.4	185.1	
AKM24	133.1	152.4	186.5	170.4	204.1	

Option Keyway

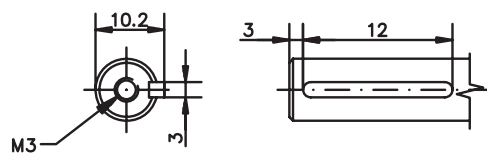

Radialkräfte am Wellenende / Radial Force at shaft end  
 Forze radiali sull'estremità dell'albero/ Fuerza radial el extremo del eje

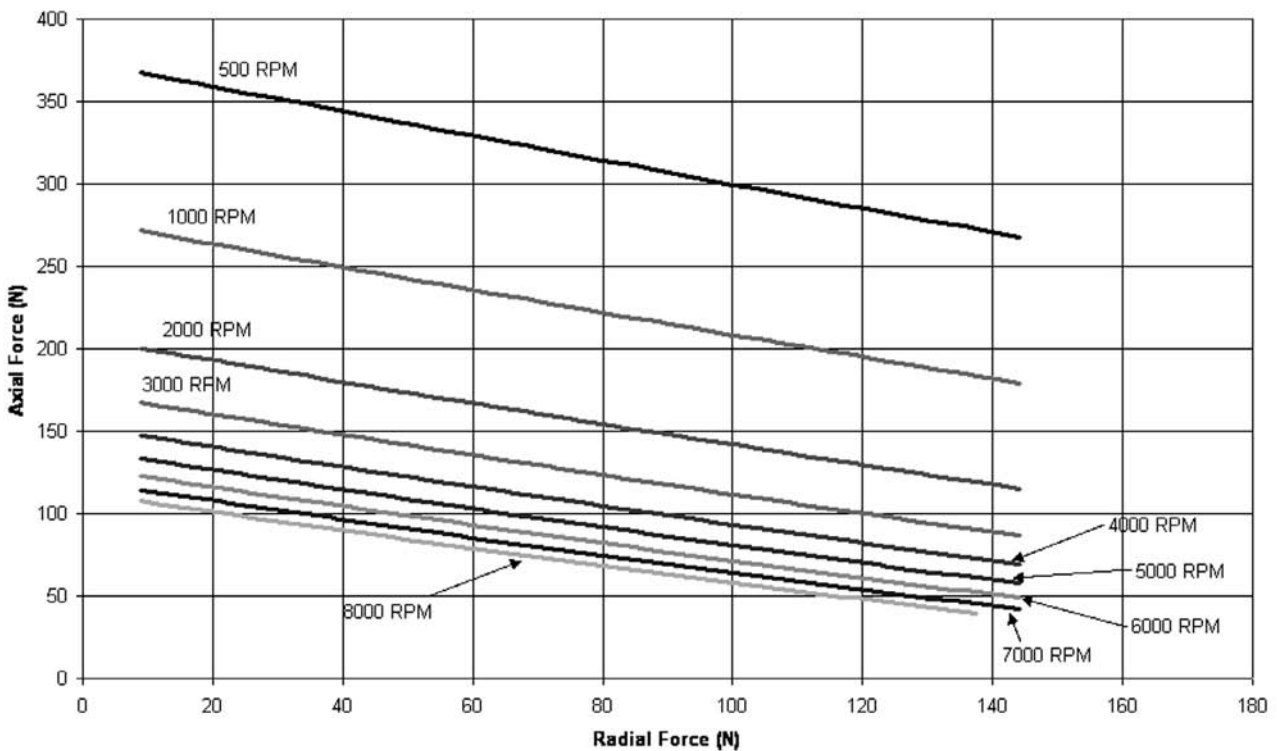



### 42.3 Dimensions/Radial Forces AKM3

Prinzipdarstellung / drawing in principle /  
 schema elementare / representación esquemática

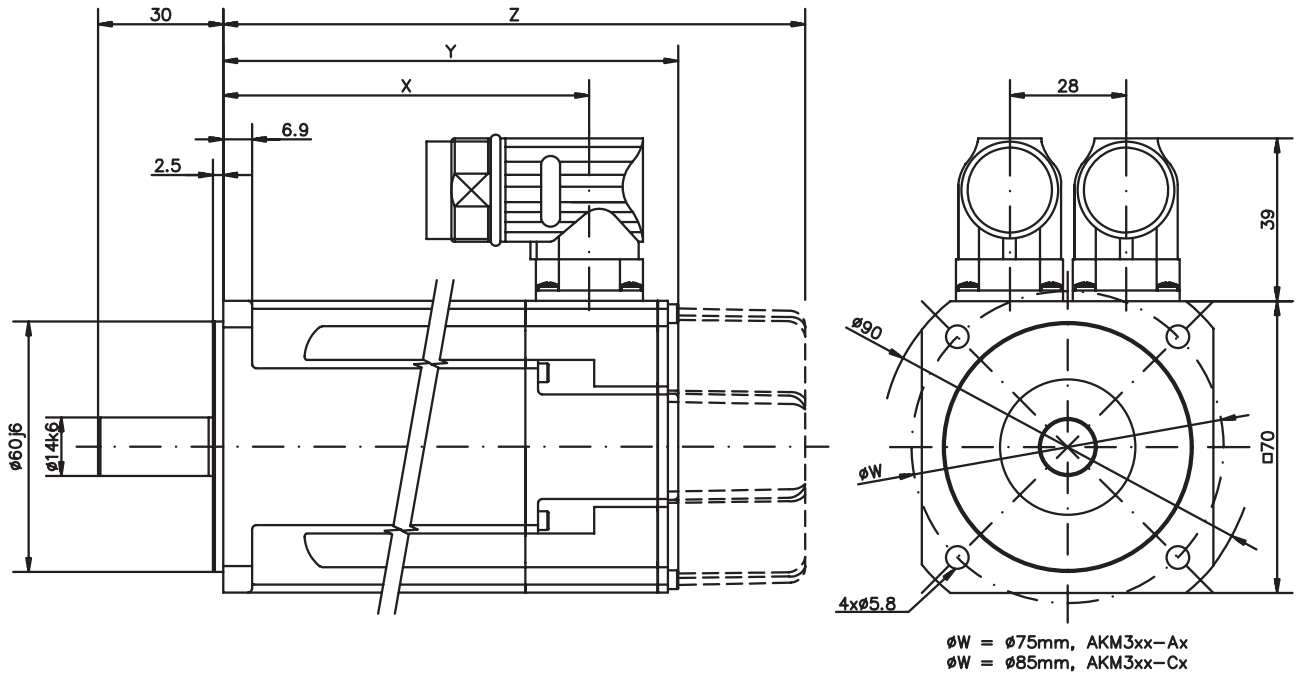

$\phi W = \phi 75\text{mm}$ , AKM3xx-Ax  
 $\phi W = \phi 85\text{mm}$ , AKM3xx-Cx

Model	X	Res/SFD/Biss/EnDat		Hiperface	
		Y	Z (Brake)	Y1	Z (Brake)
AKM31	87.9	109.8	141.3	125.3	159.3
AKM32	118.9	140.8	172.3	156.3	190.3
AKM33	149.9	171.8	203.3	187.3	221.3

Option Keyway

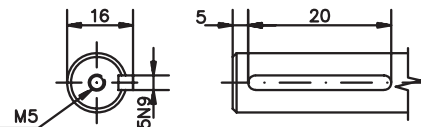

Radialkräfte am Wellenende / Radial Force at shaft end  
 Forze radiali sull'estremità dell'albero/ Fuerza radial el extremo del eje

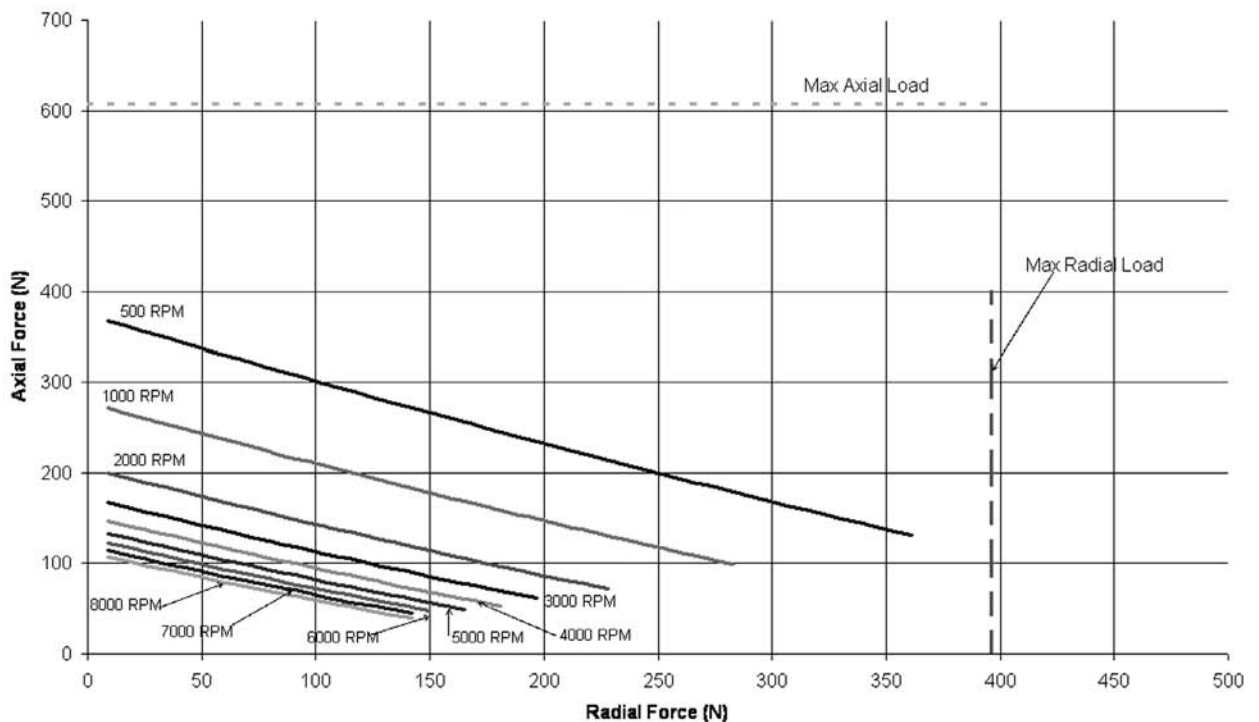

42.4 Dimensions/Radial Forces AKM4

Prinzipdarstellung / drawing in principle /  
 schema elementare / representación esquemática

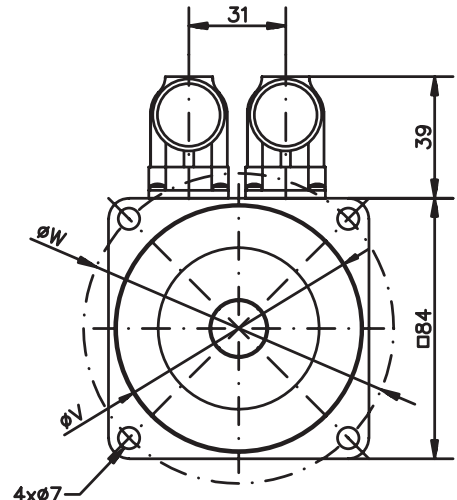
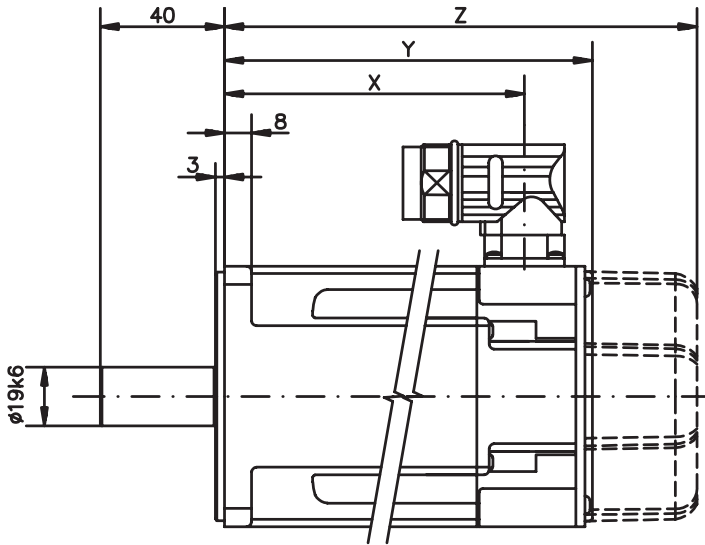

$\phi W = \phi 100, \phi V = \phi 80 j6, AKM4xx-Ax$   
 $\phi W = \phi 90, \phi V = \phi 60 j6, AKM4xx-Cx$

Option Keyway

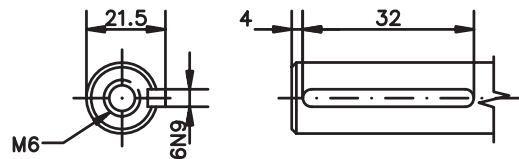

Model	X	Resolver/Encoder		ECI/EQI/HIPERFACE	
		Y	Z (brake)	Y	Z (brake)
AKM41	96.4	118.8	152.3	136.8	170.3
AKM42	125.5	147.8	181.3	165.8	199.3
AKM43	154.4	176.8	210.3	194.8	228.3
AKM44	183.4	205.8	239.3	223.8	257.3

Radialkräfte am Wellenende / Radial Force at shaft end  
 Forze radiali sull'estremità dell'albero/ Fuerza radial el extremo del eje

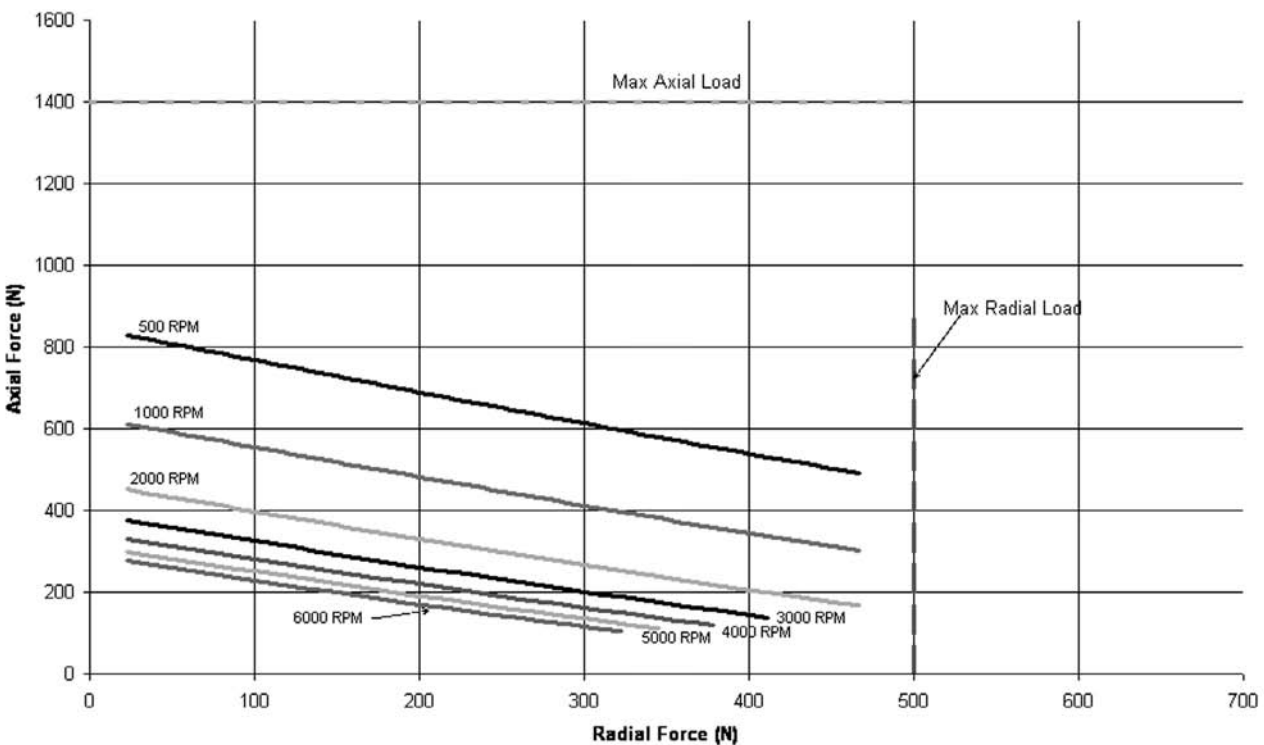

### 42.5 Dimensions/Radial Forces AKM5

Prinzipdarstellung / drawing in principle /  
 schema elementare / representación esquemática

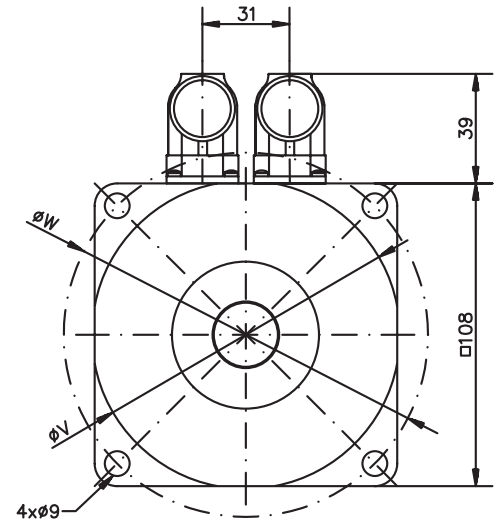
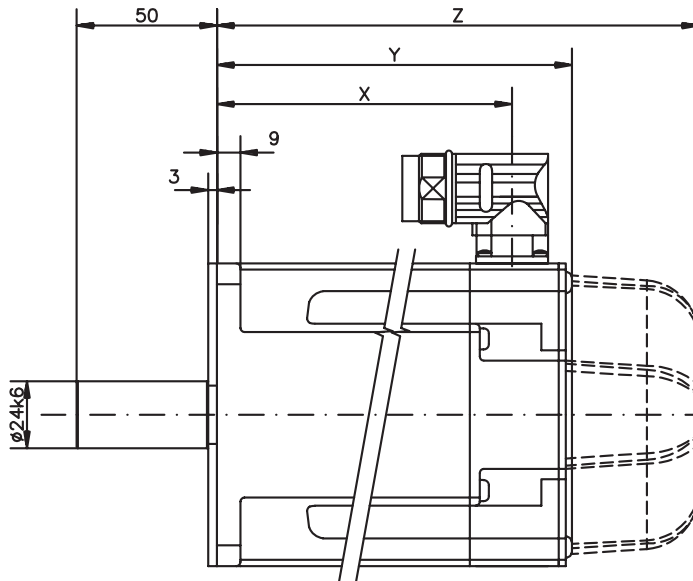

$\varnothing W = \varnothing 130$ ,  $\varnothing V = \varnothing 110j6$ , AKM5xx-Ax  
 $\varnothing W = \varnothing 115$ ,  $\varnothing V = \varnothing 95j6$ , AKM5xx-Cx

Model	X	Resolver/Comcoder		Encoder	
		Y	Z (brake)	Y	Z (brake)
AKM51	105.3	127.5	172.5	146.0	189.0
AKM52	136.3	158.5	203.5	177.0	220.0
AKM53	167.3	189.5	234.5	208.0	251.0
AKM54	198.3	220.5	265.5	239.0	282.0

#### Option Keyway

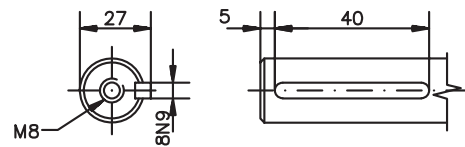

#### Radialkräfte am Wellenende / Radial Force at shaft end Forze radiali sull'estremità dell'albero/ Fuerza radial el extremo del eje

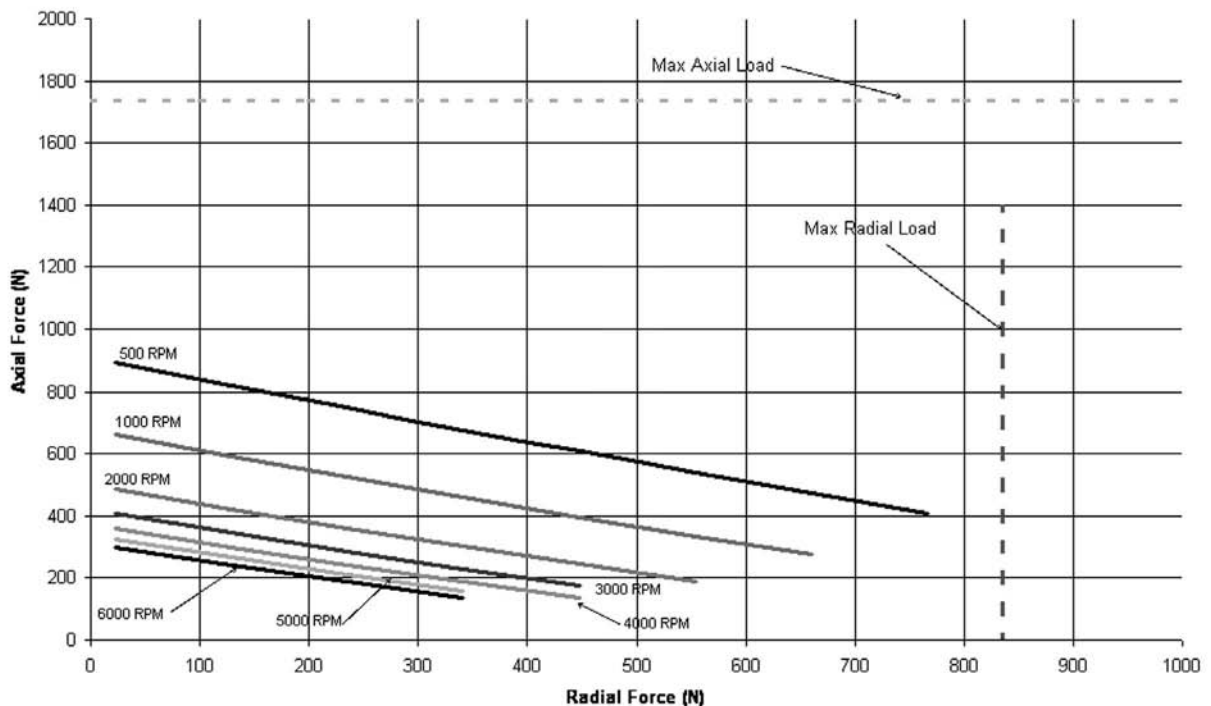

42.6 Dimensions/Radial Forces AKM6

Prinzipdarstellung / drawing in principle /  
 schema elementare / representación esquemática

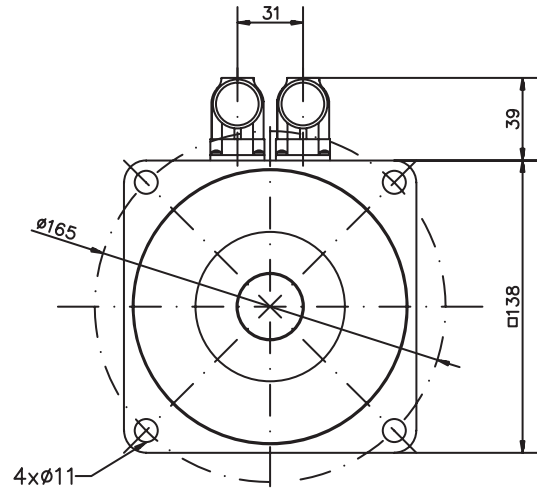
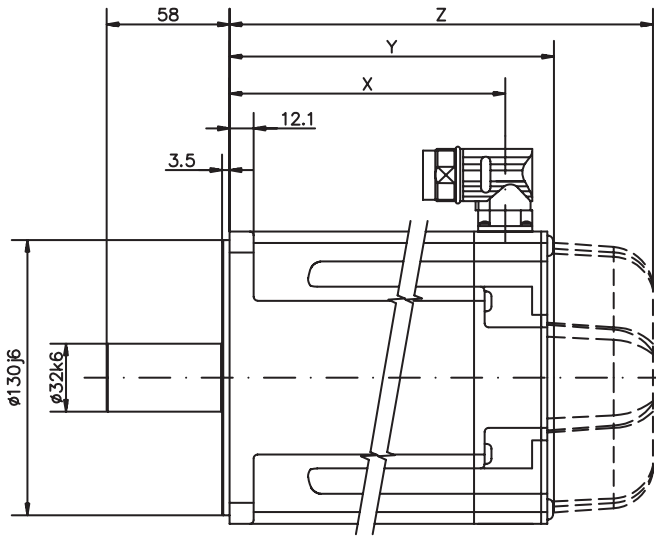

Model	X	Resolver/Comcoder		Encoder	
		Y	Z (brake)	Y	Z (brake)
AKM62	130.5	153.7	200.7	172.2	219.7
AKM63	155.5	178.7	225.7	197.2	244.7
AKM64	180.5	203.7	250.7	222.2	269.7
AKM65	205.5	228.7	275.7	247.2	294.7

Option Keyway

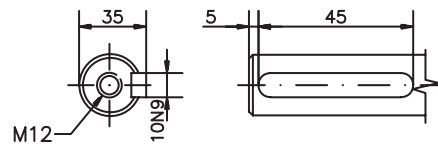

Radialkräfte am Wellenende / Radial Force at shaft end  
 Forze radiali sull'estremità dell'albero/ Fuerza radial el extremo del eje

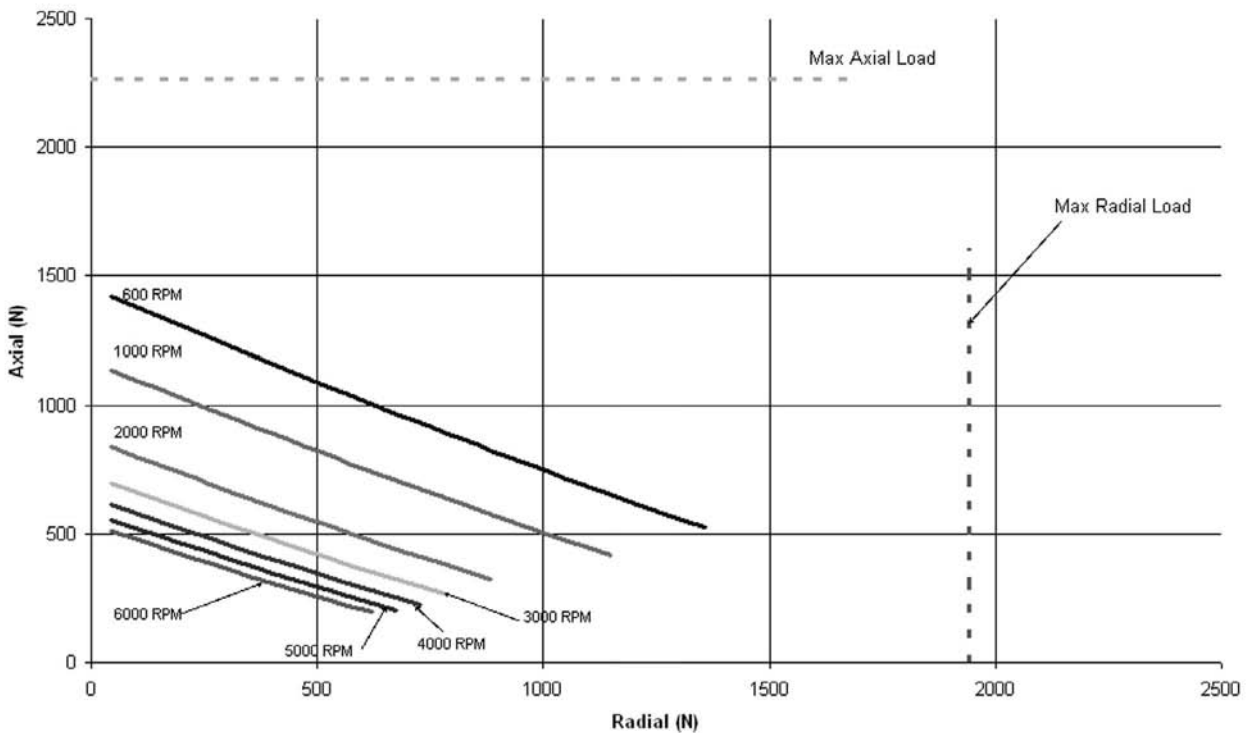

42.7 Dimensions/Radial Forces AKM7

Prinzipdarstellung / drawing in principle /  
 schema elementare / representación esquemática

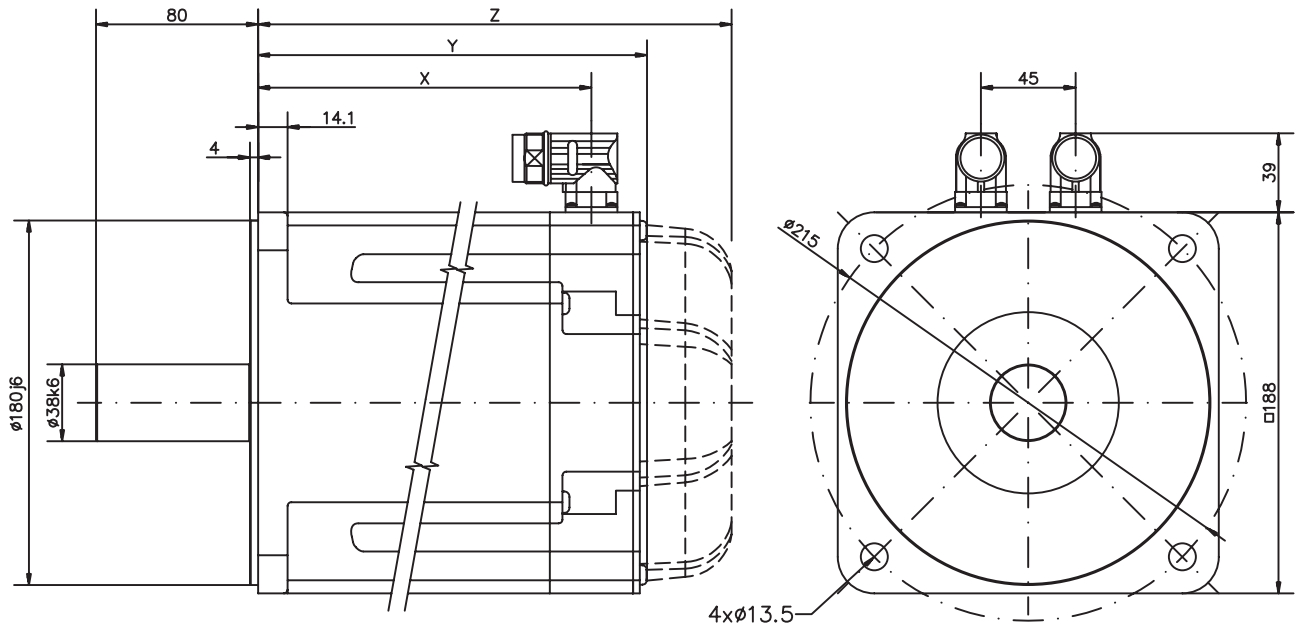

Model	X	Resolver/Comcoder		Encoder	
		Y	Z (brake)	Y	Z (brake)
AKM72	164.5	192.5	234.5	201.7	253.3
AKM73	198.5	226.5	268.5	235.7	287.3
AKM74	232.5	260.5	302.5	269.7	321.3

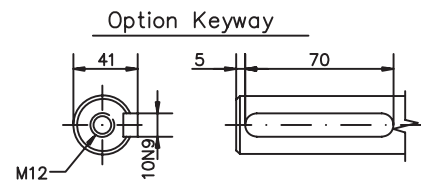

Radialkräfte am Wellenende / Radial Force at shaft end  
 Forze radiali sull'estremità dell'albero/ Fuerza radial el extremo del eje

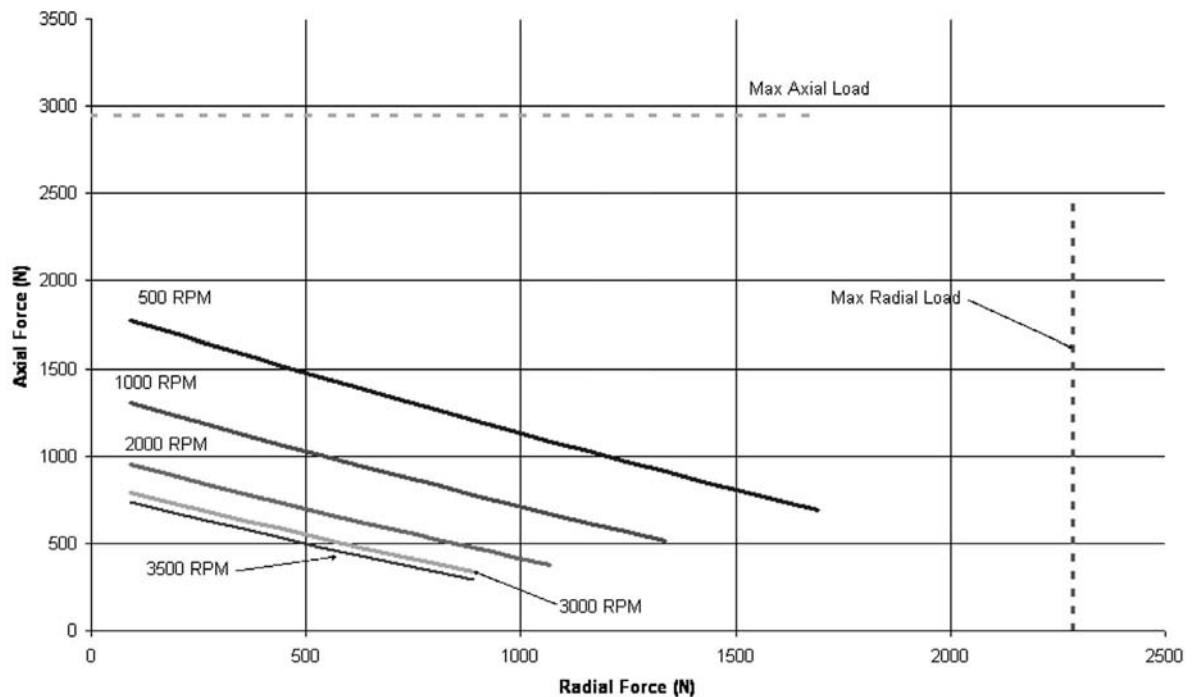

42.8 Dimensions/Radial Forces AKM8

42.8.1 Dimensions AKM8x with terminal box

Prinzipdarstellung / drawing in principle /  
 schema elementare / representación esquemática

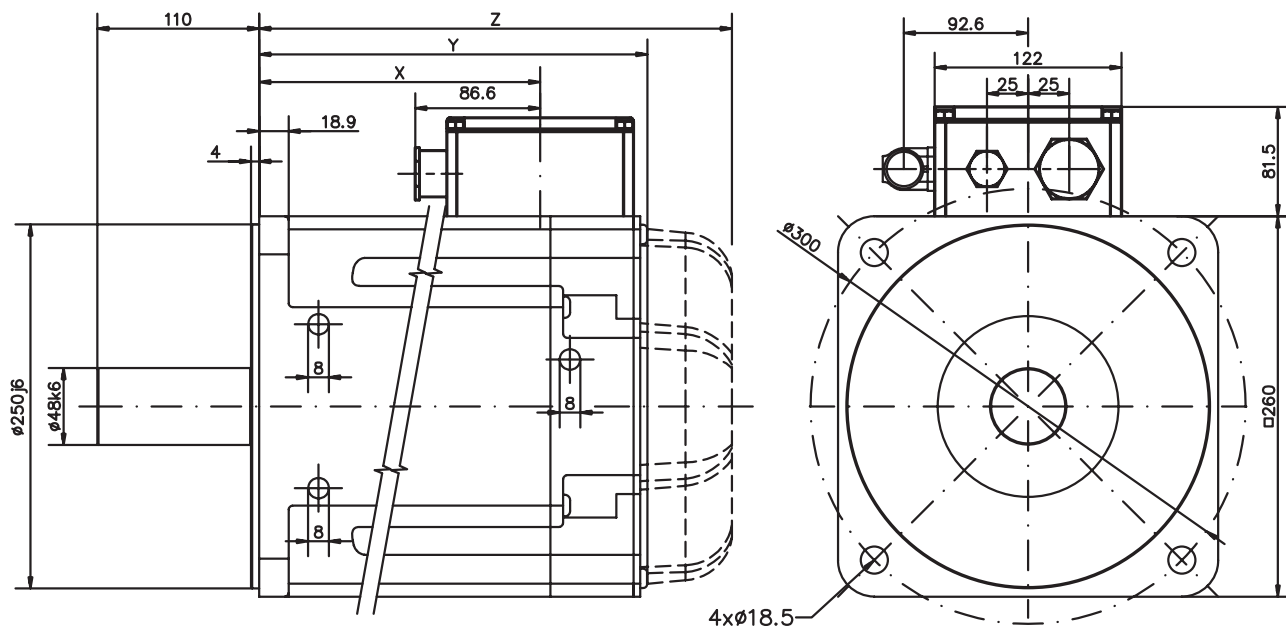

Dimensions

Model	X	Y	Z (brake)
AKM82	189.4	263.4	329.4
AKM83	269.9	343.9	409.9
AKM84	350.4	424.4	490.4

Transport

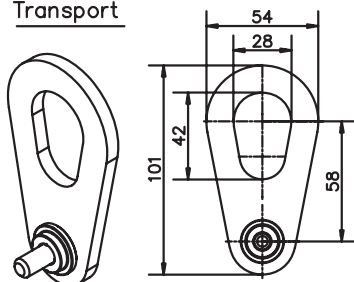

Option Keyway

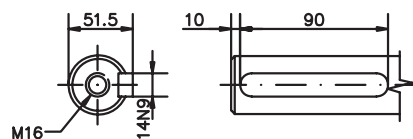

Terminal Box

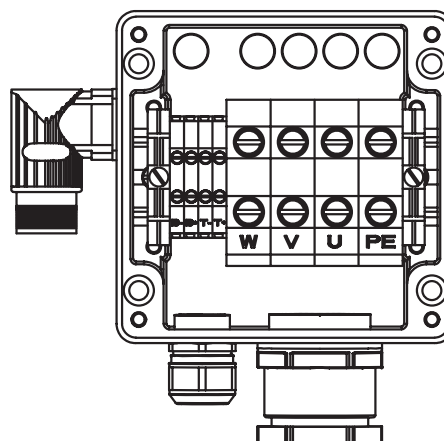

42.8.2 Dimensions AKM82 with power connector

Prinzipdarstellung / drawing in principle /  
 schema elementare / representación esquemática

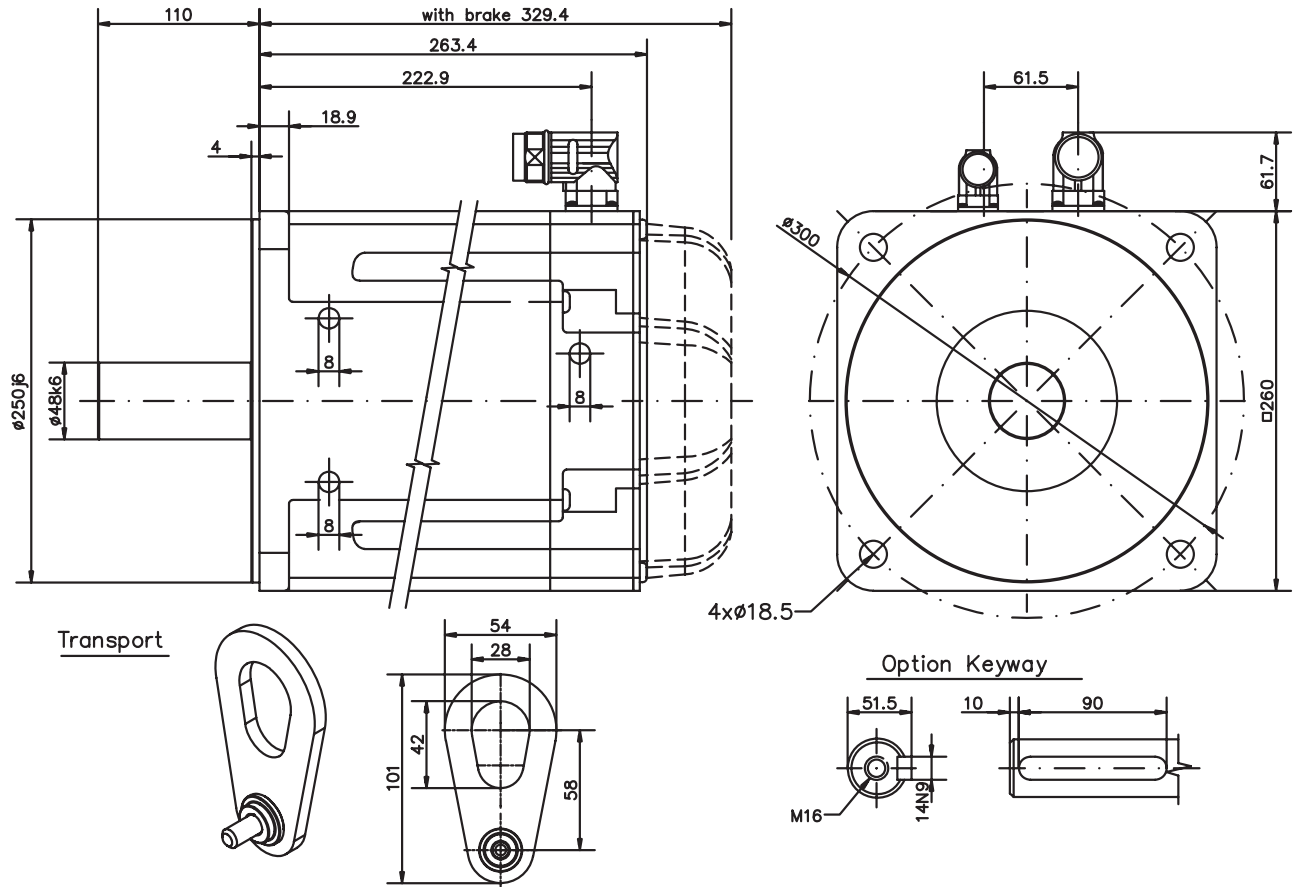

42.8.3 Radial Forces AKM8

Radialkräfte am Wellenende / Radial Force at shaft end  
 Forze radiali sull'estremità dell'albero/ Fuerza radial el extremo del eje

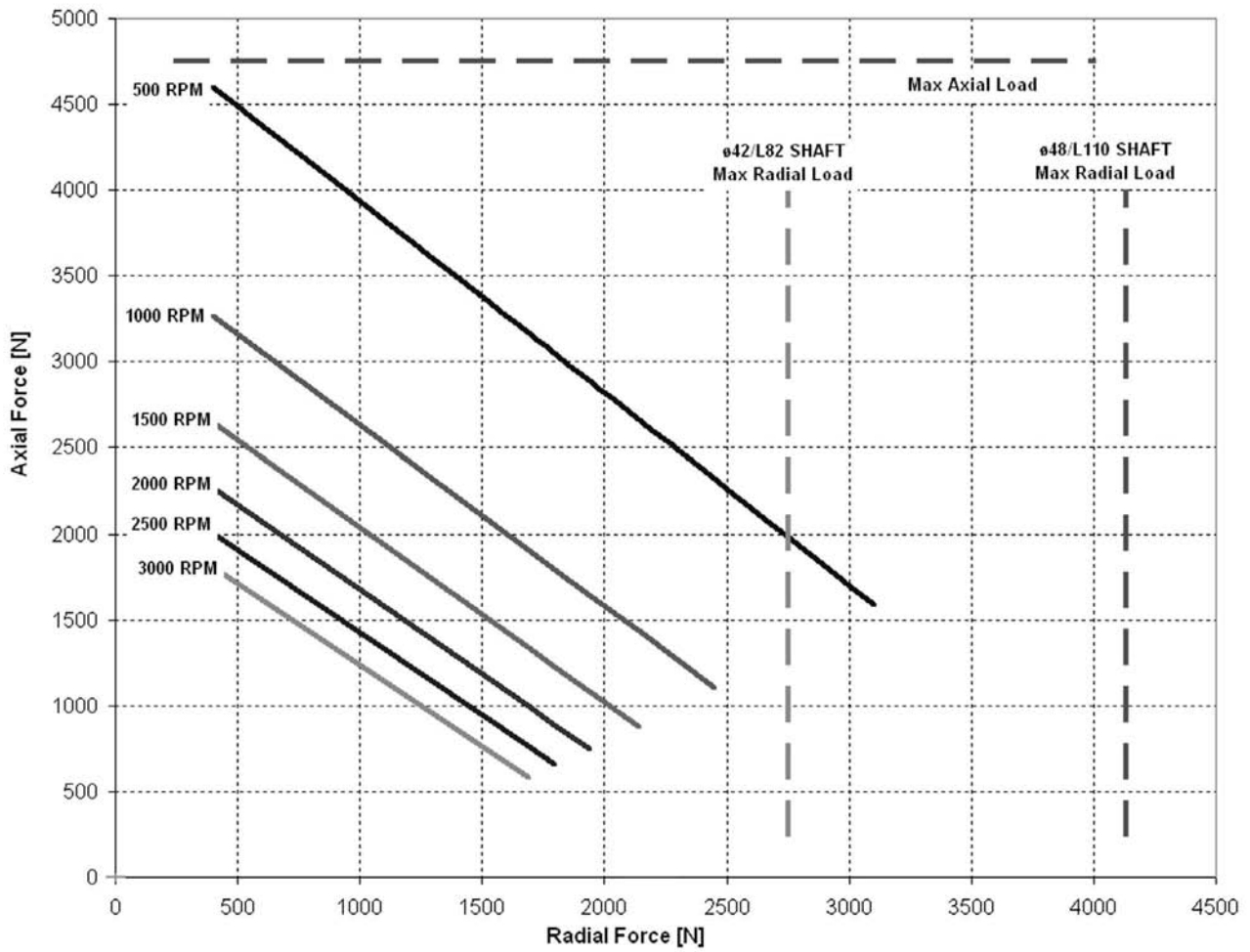



### 43 Wiring diagrams

#### 43.1 Wiring Diagram Motor & Resolver

Draufsicht Einbaustecker  
 Top view, built-in plug  
 Vista in pianta  
 Vista enchufe incorporado

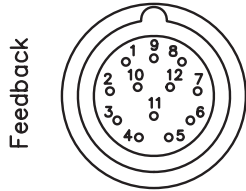

Draufsicht Einbaustecker  
 Top view, built-in plug  
 Vista in pianta  
 Vista enchufe incorporado

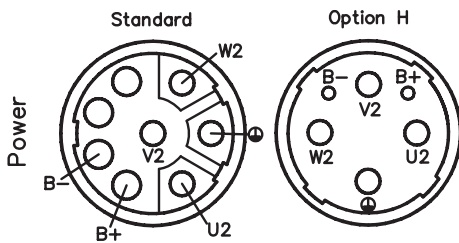

Klemmkasten AKM8  
 Terminal box AKM8  
 Scatola di serrage AKM8  
 Caja de sujeción AKM8

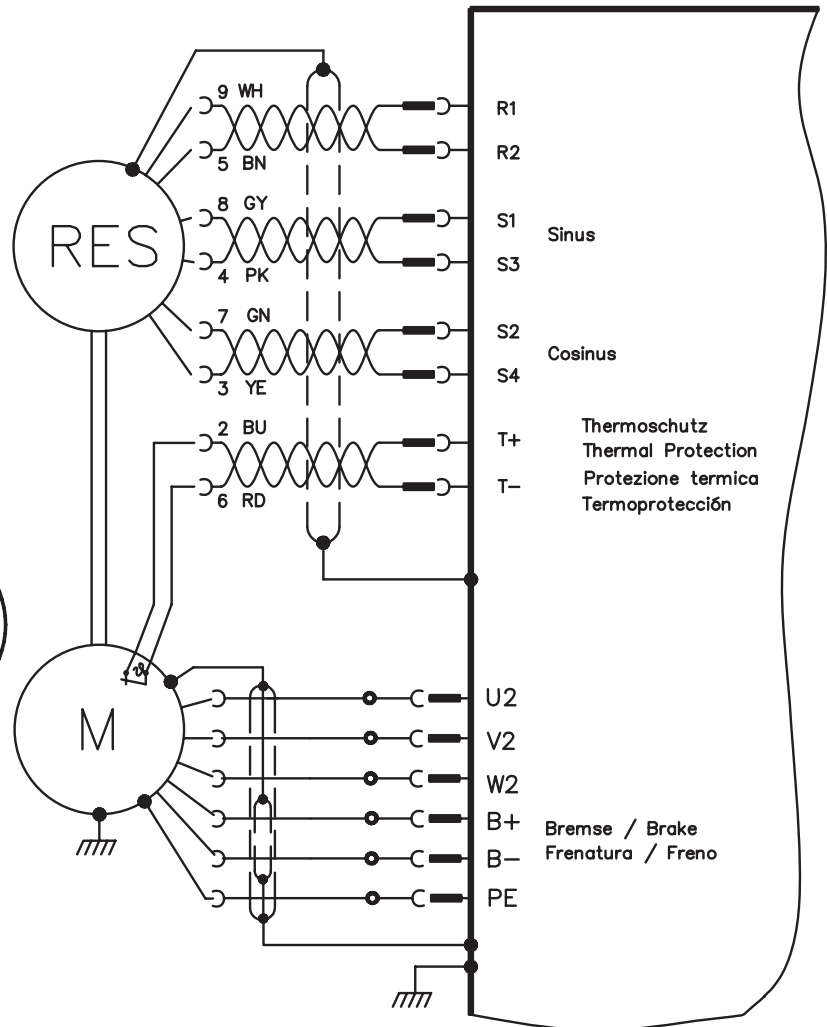
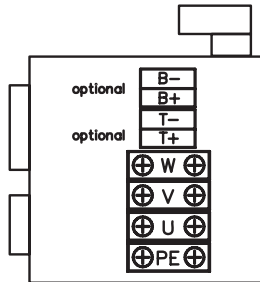

Rundstecker, 12 pol.  
 Connector, round, 12 pins  
 Connecteur rond 12 br.  
 Enchufe redondo 12-pol.

Schirm intern auf Metallgehäuse gelegt  
 Shield connected to metallic cover  
 Schermo collegato internamente al corpo metallico  
 Protezione interna sobre cuerpo metalizado

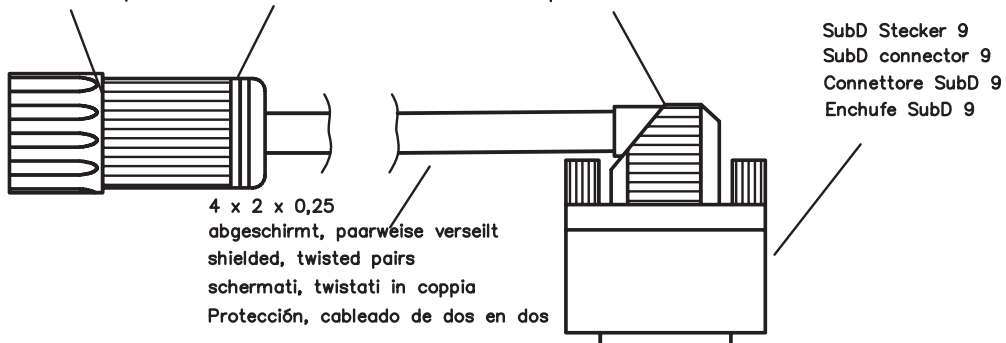

### 43.2 Wiring Diagram Motor & Encoder with EnDat (ECx, EQx)

Eingebaute EnDat Encoder sind nicht RoHS konform!  
 Built-in EnDat Encoders are not RoHS conform!  
 I codificatori incorporati di EnDat non sono RoHS si conformano!  
 ¡Los codificadores incorporados de EnDat no son RoHS conforman!

Draufsicht Einbaustecker  
 Top view, built-in plug  
 Vista in pianta  
 Vista enchufe incorporado

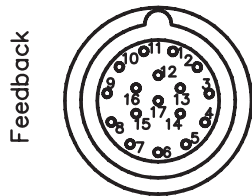

Draufsicht Einbaustecker  
 Top view, built-in plug  
 Vista in pianta  
 Vista enchufe incorporado

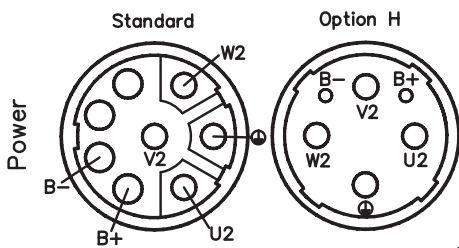

Klemmkasten AKM8  
 Terminal box AKM8  
 Scatola di serrage AKM8  
 Caja de sujeción AKM8

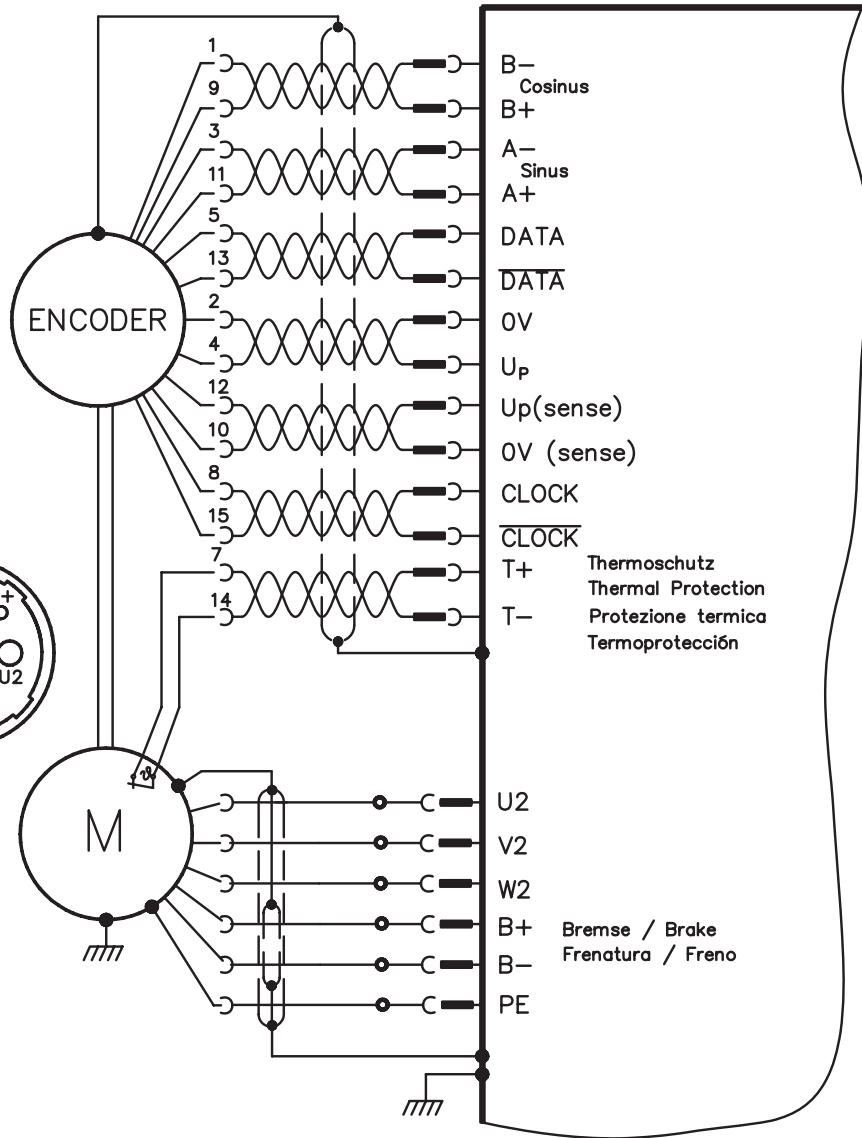
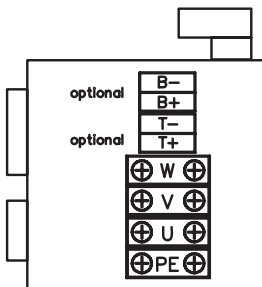

Rundstecker, 17 pol.  
 Connector, round, 17 pins  
 Connecteur rond 17br.  
 Enchufe redondo 17-pol.

Schirm intern auf Metallgehäuse gelegt  
 Shield connected to metallic cover  
 Schermo collegato internamente al corpo metallico  
 Protección interna sobre cuerpo metalizado

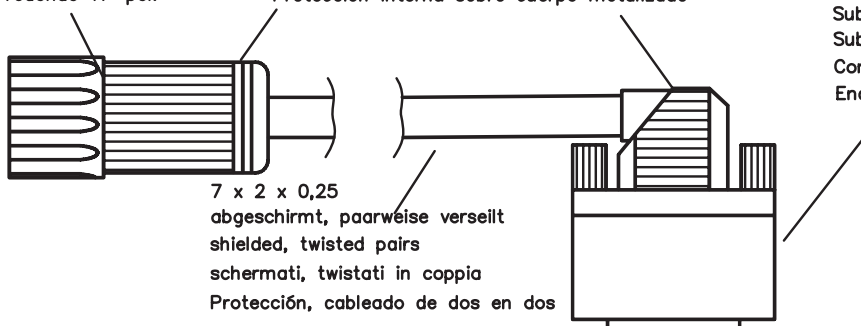

SubD Stecker 15  
 SubD connector 15  
 Connettore SubD 15  
 Enchufe SubD 15

7 x 2 x 0,25  
 abgeschirmt, paarweise verseilt  
 shielded, twisted pairs  
 schermati, twistati in coppia  
 Protección, cableado de dos en dos

43.3 Wiring Diagram Motor & Smart Feedback Device (SFD)

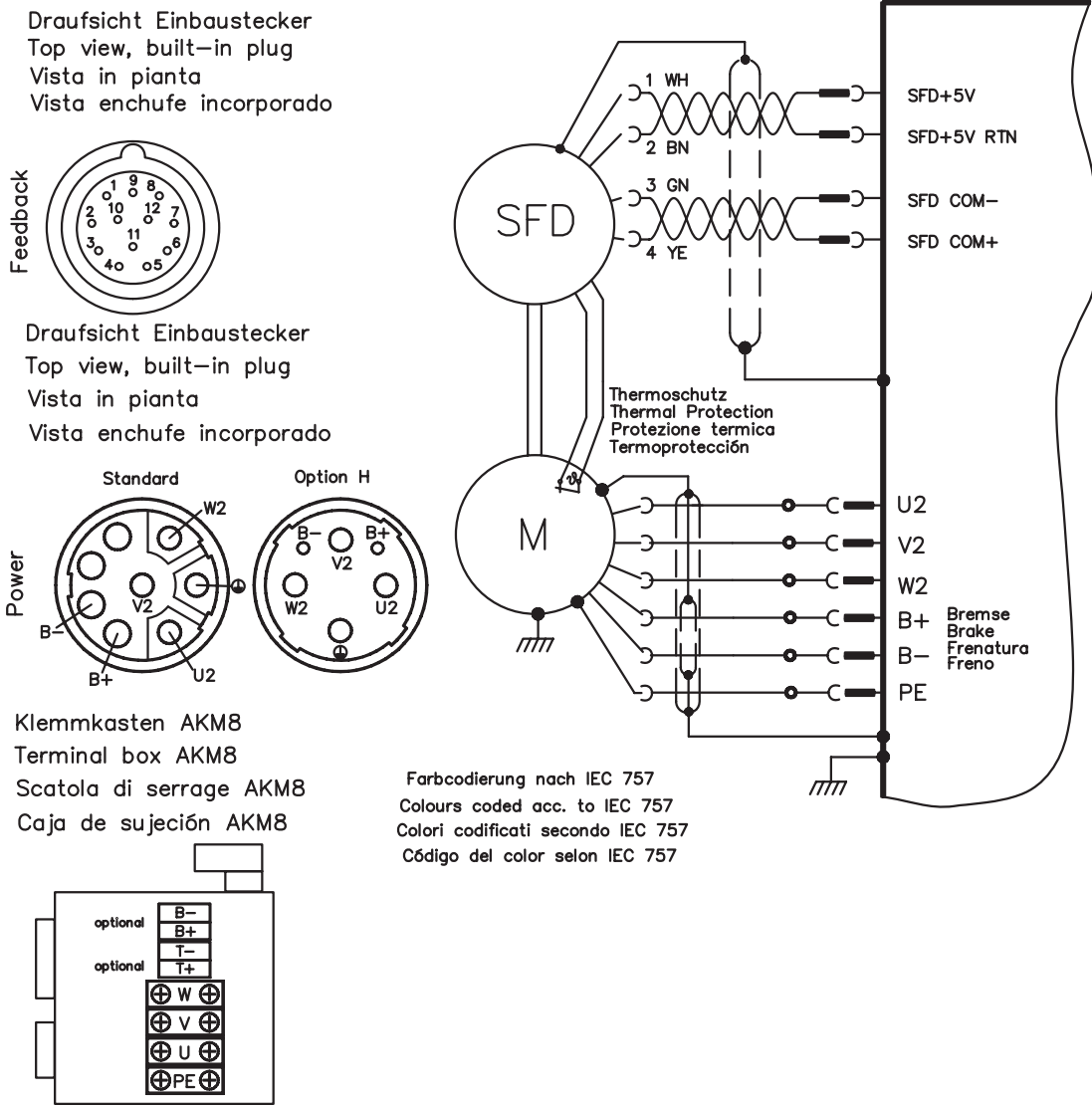

43.4 Wiring Diagram Motor & ComCoder

Draufsicht Einbaustecker  
 Top view, built-in plug  
 Vista in pianta  
 Vista enchufe incorporado

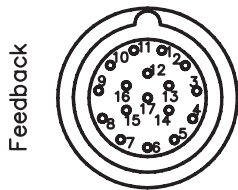

Draufsicht Einbaustecker  
 Top view, built-in plug  
 Vista in pianta  
 Vista enchufe incorporado

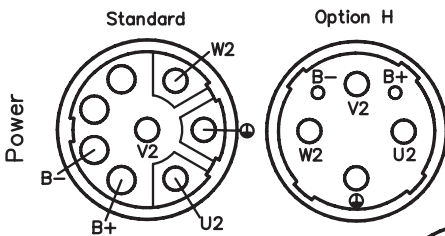

Klemmkasten AKM8  
 Terminal box AKM8  
 Scatola di serrage AKM8  
 Caja de sujeción AKM8

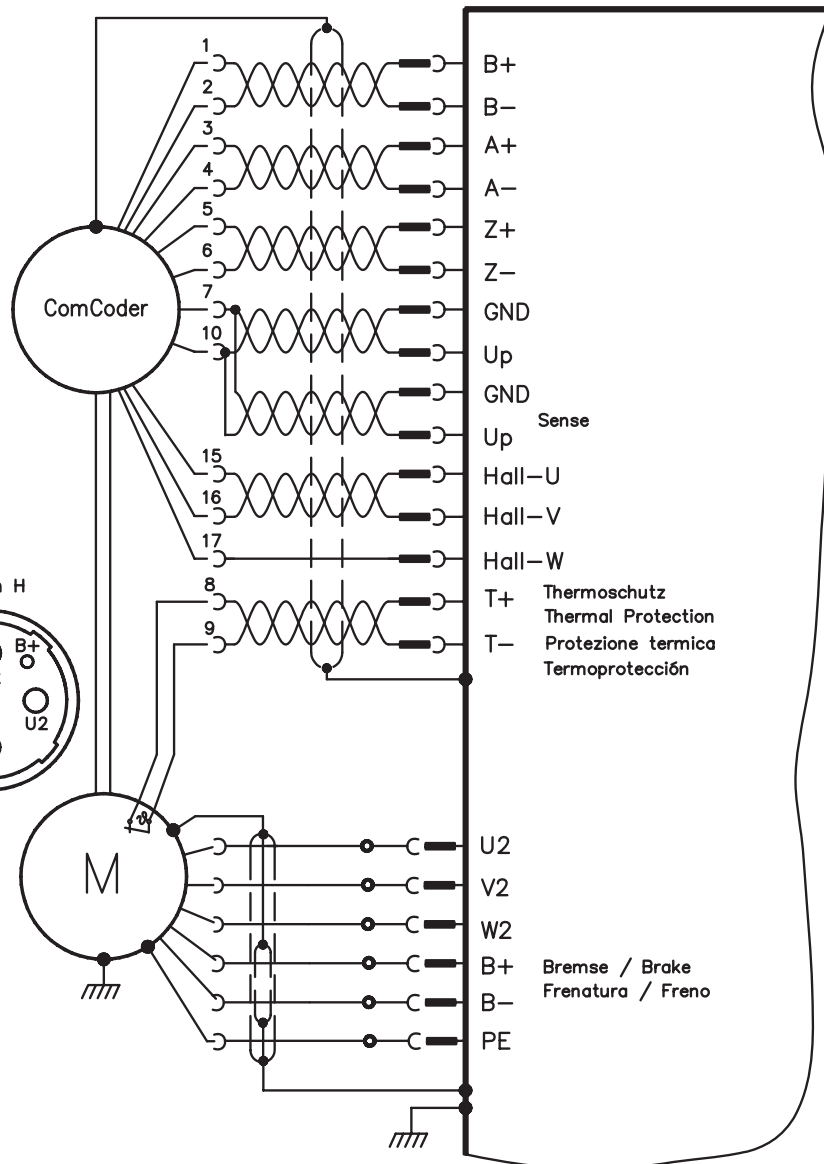
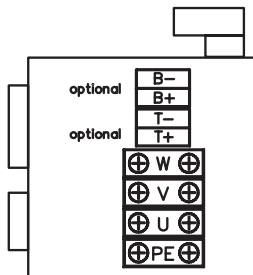

Rundstecker, 17 pol.  
 Connector, round, 17 pins  
 Connecteur rond 17br.  
 Enchufe redondo 17-pol.

Schirm intern auf Metallgehäuse gelegt  
 Shield connected to metallic cover  
 Schermo collegato internamente al corpo metallico  
 Protección interna sobre cuerpo metalizado

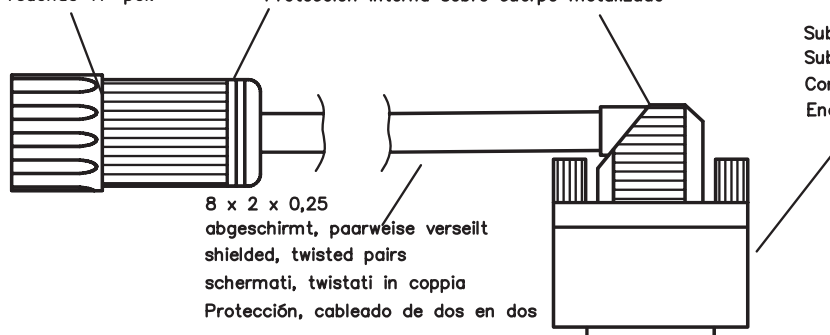

SubD Stecker 15  
 SubD connector 15  
 Connettore SubD 15  
 Enchufe SubD 15

43.5 Wiring Diagram Motor & Encoder with BISS

Draufsicht Einbaustecker  
 Top view, built-in plug  
 Vista in pianta  
 Vista enchufe incorporado

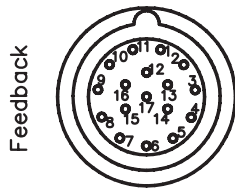

Draufsicht Einbaustecker  
 Top view, built-in plug  
 Vista in pianta  
 Vista enchufe incorporado

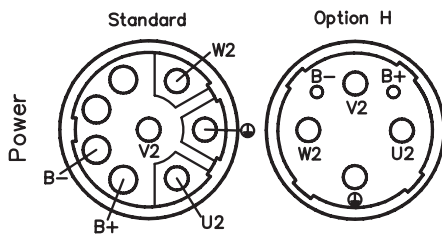

Klemmkasten AKM8  
 Terminal box AKM8  
 Scatola di serrage AKM8  
 Caja de sujeción AKM8

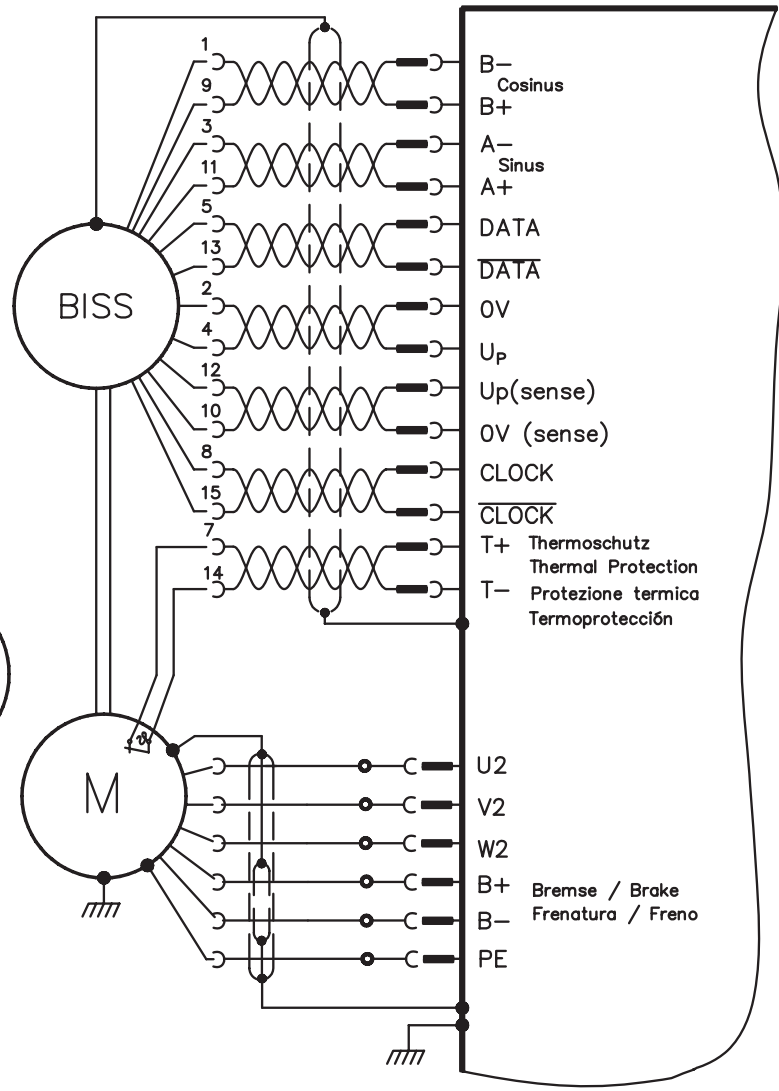
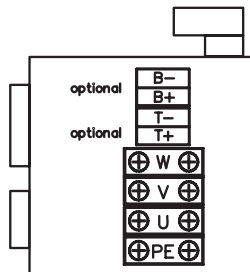

Rundstecker, 17 pol.  
 Connector, round, 17 pins  
 Connecteur rond 17br.  
 Enchufe redondo 17-pol.

Schirm intern auf Metallgehäuse gelegt  
 Shield connected to metallic cover  
 Schermo collegato internamente al corpo metallico  
 Protección interna sobre cuerpo metalizado

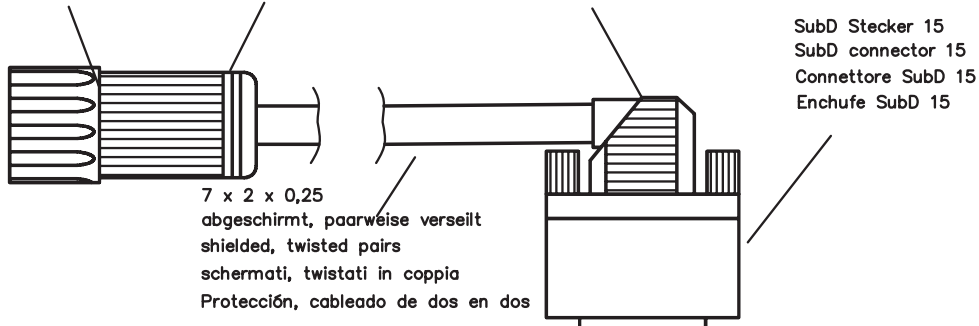

43.6 Wiring Diagram Motor & Encoder with Hiperface

Draufsicht Einbaustecker  
 Top view, built-in plug  
 Vista in pianta  
 Vista enchufe incorporado

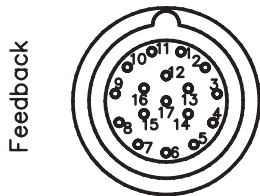

Draufsicht Einbaustecker  
 Top view, built-in plug  
 Vista in pianta  
 Vista enchufe incorporado

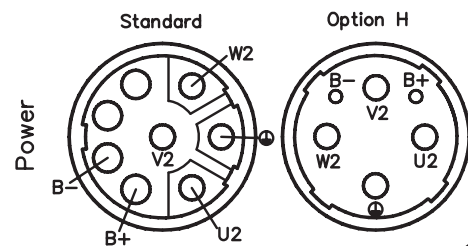

Klemmkasten AKM8  
 Terminal box AKM8  
 Scatola di serrage AKM8  
 Caja de sujeción AKM8

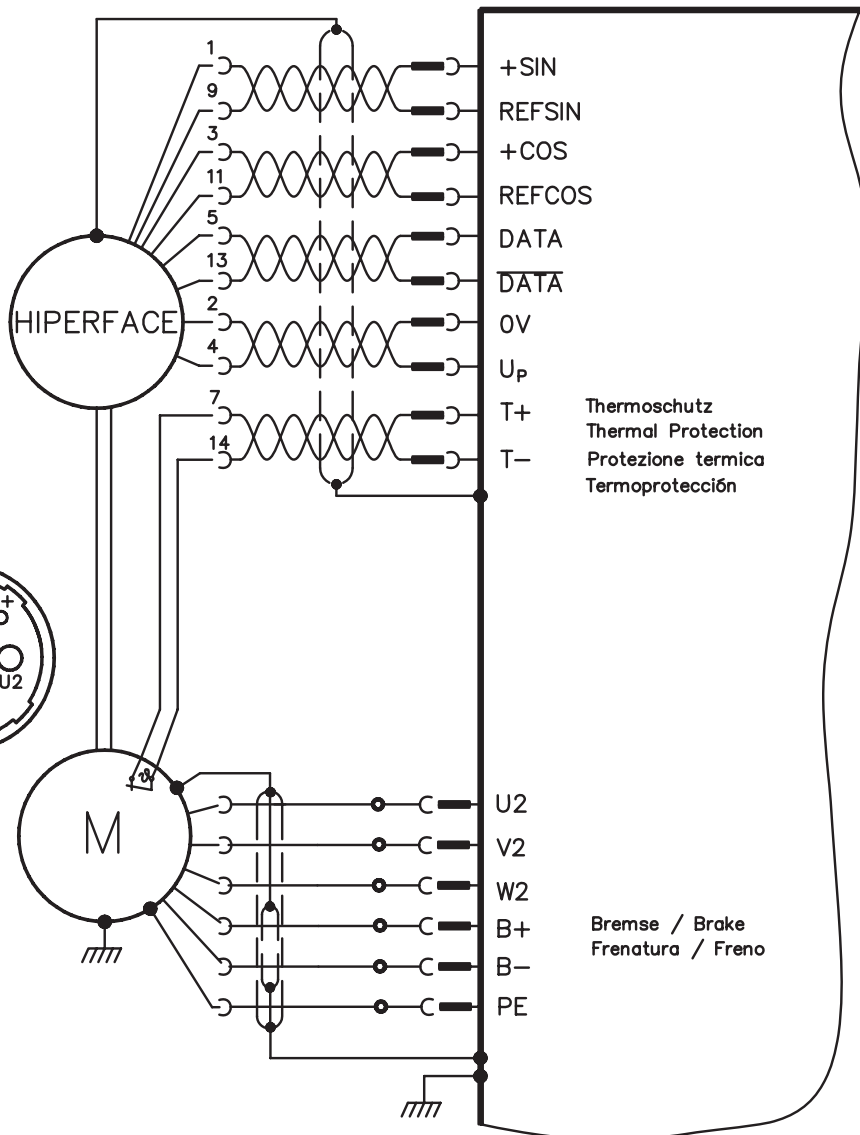
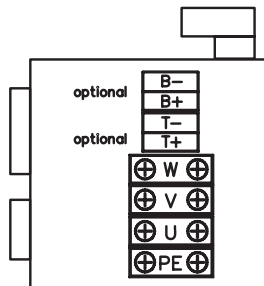

Rundstecker, 17 pol.  
 Connector, round, 17 pins  
 Connecteur rond 17br.  
 Enchufe redondo 17-pol.

Schirm intern auf Metallgehäuse gelegt  
 Shield connected to metallic cover  
 Schermo collegato internamente al corpo metallico  
 Protección interna sobre cuerpo metalizado

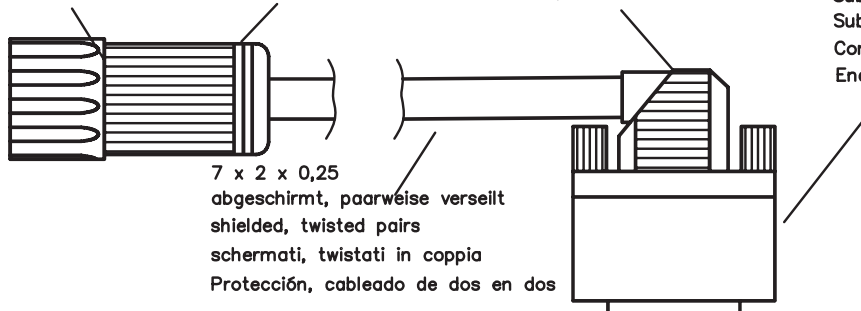

This page has been deliberately left blank.

### **Service**

Wir bieten Ihnen einen kompetenten und schnellen Service. Wählen Sie das zuständige regionale Vertriebsbüro in Deutschland oder kontaktieren Sie den europäischen oder nordamerikanischen Kundenservice.

### **Servizio**

Ci impegniamo a fornire un servizio di qualità al cliente. Per servire nel senso più efficace, prego mettasi in contatto con il vostro rappresentante locale per assistenza. Contattateci per maggiori informazioni.

### **Service**

We are committed to quality customer service. In order to serve in the most effective way, please contact your local sales representative for assistance. If you are unaware of your local sales representative, please contact us.

### **Servicio**

Queremos ofrecer al cliente un servicio de calidad. Para ello les agradecemos que contacten con su representante local de ventas. En el caso de que no lo conozcan, no duden en ponerse en contacto con nosotros en las siguientes direcciones.

## **Europe**

### **Kollmorgen Customer Support Europe**

Internet [www.kollmorgen.com](http://www.kollmorgen.com)

E-Mail [technik@kollmorgen.com](mailto:technik@kollmorgen.com)

Phone: +49 (0)2102 - 9394 - 2250

Fax: +49 (0)2102 - 9394 - 3110

## **North America**

### **Kollmorgen Customer Support North America**

Internet [www.kollmorgen.com](http://www.kollmorgen.com)

E-Mail [support@kollmorgen.com](mailto:support@kollmorgen.com)

Phone: +1 - 540 - 633 - 3545

Fax: +1 - 540 - 639 - 4162

**KOLLMORGEN**®

---