

AksIM™ off-axis rotary absolute encoder



AksIM™ is a non-contact high performance off-axis absolute rotary encoder designed for integration into space-constrained applications. A hollow ring, true absolute functionality and high speed operation make this encoder suitable for many applications.

The AksIM™ encoder system consists of an axially magnetised ring and a readhead.

The encoders come with SSI, SPI, PWM, BiSS, asynchronous serial RS422 and USB communication interfaces and offer a range of binary resolutions to 20 bits per revolution.

The encoder operates from $-30\text{ }^{\circ}\text{C}$ to $+85\text{ }^{\circ}\text{C}$ and is resistant to shock and vibrations.

The AksIM™ encoder has a built-in advanced self-monitoring function, continually checking several internal parameters. Error reporting, warnings and other status signals are available on all digital interfaces and are visualised with the on-board LED.

The AksIM™ encoder system is suitable for use in industrial and medical applications.

A typical application is a robotic arm joint with a cable feed running through the ring or a precision gearbox where the ring is attached onto the main transmission shaft.

Custom design service for OEM integration is also available.

- True absolute system
- Custom magnetic sensor ASIC
- No hysteresis
- Resolutions up to 20 bits
- Multiturn counter option
- High speed operation
- Low profile, non-contact
- Built-in self-monitoring
- Integrated status LED
- SSI, SPI, PWM, BiSS, asynchronous serial RS422 or USB communication interface
- Corrosion resistant magnetic ring

Storage and handling

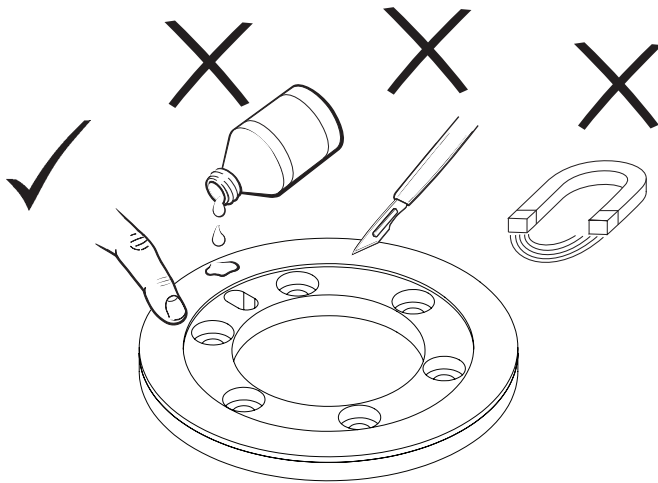

WARNING: Magnetic rings should not be exposed to magnetic field densities higher than 50 mT on its surface. Magnetic fields higher than 50 mT can damage the ring.

Chemical resistance

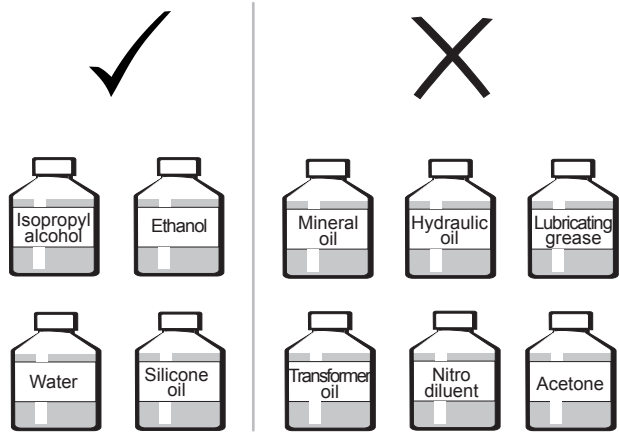

Readhead

The MHA readhead with cable is resistant to a range of greases and oils commonly found in industry. If the encoder is to be used in the area without air, it is recommended to use silicone-based oils or demineralised water. Before any long-term immersion into any liquid or gas, please consult your local sales representative. Encoder is not vacuum compatible.

Magnetic ring

The magnetized rubber on the ring does not withstand the following chemicals: mineral oils, hydraulic oils, most of transformer oils, lubricating grease, nitro diluent, acetone etc. The following have been tested and are not recommended:

- ISO VG 46 (SAE MS1004 type HM)
- Nytro 10 XN
- MIDEL 7131
- Shell Diala S3 ZX-I.

The rings are resistant to isopropyl-alcohol, ethanol, water and some silicone-based oils.



WARNING!

ESD protection
Readhead is ESD sensitive - handle with care. Do not touch electronic circuit, wires or sensor area without proper ESD protection or outside of ESD controlled environment.

Dimensions

Dimensions and tolerances in mm.

Ring MRA7

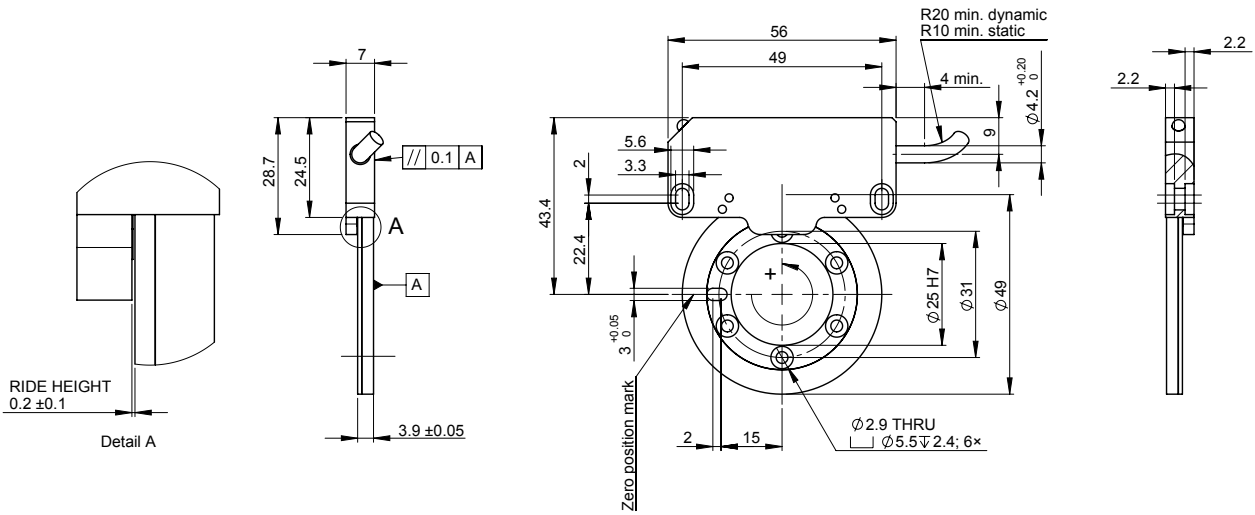

NOTE:
CCW positive measuring direction.

Ring MRA8

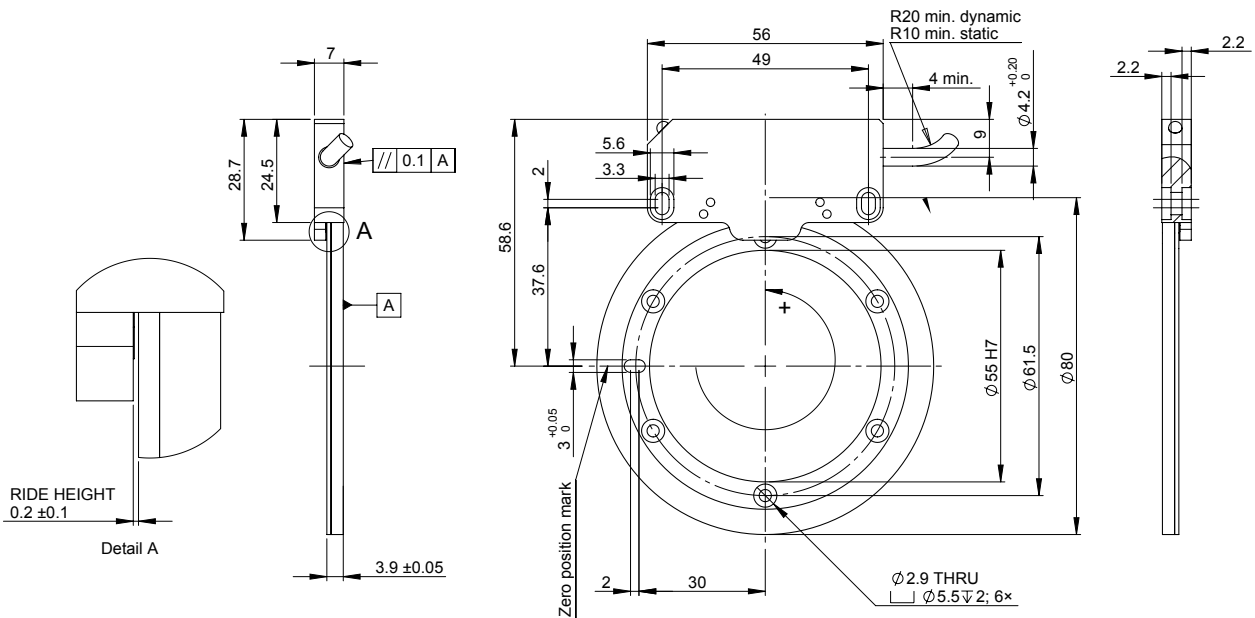

NOTE:
CCW positive measuring direction.

Technical specifications

System data	
Reading type	Axial reading
Resolution	From 15 to 20 bit and 16 bit multiturn counter option (see chapter Available resolutions on page 8)
Maximum speed	> 10,000 rpm
Encoder accuracy	±0.05° (before installation - errors caused by mounting inaccuracy of the readhead, ring and drive shaft are not included)
Final system accuracy	Typ. ±0.1° (within defined installation tolerances - see chapter Installation instructions on page 5)
Hysteresis	Less than unit of resolution
Repeatability	Better than unit of resolution
Electrical data	
Supply voltage	4 V to 6 V – voltage on readhead. Consider voltage drop over cable.
Set-up time	10 ms (first data ready after switch-on)
Power consumption	Typ. 115 mA, max. 150 mA
Voltage drop over cable	~ 55 mV/m – without load
Output load	PWM, SPI Max. ±20 mA RS422 120 mA short term, 60 mA limited
ESD protection	HBM, Class 2, max. ±2 kV (as per Mil-Std 883 Method 3015.7)
Mechanical data	
Available ring sizes (outer diameter)	49 mm (ring MRA7) 80 mm (ring MRA8)
Material type	Ring EN 1.4005 / AISI416 or EN 1.4104 / AISI430F with glued rubber filled with ferrite particles
Mass	Readhead (with 1 m cable, no connector) 45 g Ring MRA7 32 g Ring MRA8 64 g
Inertia	Ring MRA7 13.1 kg×mm ² Ring MRA8 79.1 kg×mm ²
Cable	Ø4.2 ±0.2 mm, PUR highly flexible cable, drag-chain compatible, double-shielded See page 7 for detailed specifications (not valid for USB cable).
Environmental data	
Temperature	Operating –30 °C to +85 °C with static cable –10 °C to +80 °C with cable under dynamic conditions Storage –40 °C to +85 °C
Humidity	0 to 100 % (condensation permitted)
Environmental protection	IP64 (protected against dust and splashing water)
Vibrations	300 m/s ² 55-2000 Hz (IEC 60068-2-6)
Shock	300 m/s ² (IEC 60068-2-27), 11 ms, half sine
External magnetic field	Max ±3 mT (DC or AC) on top side of readhead

Status indicator LED

The LED provides visual feedback of signal strength, error condition and is used for set-up and diagnostics.

Flashing LED indicates the encoder is powered but communication has not been established. When communication is running at a rate of minimum 5 readings per second LED is constantly lit. Repeatably two short red flashes indicate the readhead can not start.

LED	Status
Green	Normal operation; position data is valid
Orange	Warning; position is valid, but the resolution and/or accuracy might be out of specification. Some operating conditions are outside limits.
Red	Error; position data is not valid
No light	No power supply

Installation instructions

Axial position adjustment (ride height)

The nominal gap between the sensor on the readhead and the rubber on the ring is 0.2 mm \pm 0.1 mm. To achieve this, the base of the ring should be in the same level as the bottom of the readhead. See "Detail A" section of the drawing on page 3.

Any nonmagnetic tool with 0.2 mm thickness can be used to mechanically check the ride height between the sensor and the ring. The integrated LED can be used as an indicator. When the correct ride height is achieved, the LED glows green and does not change colour when the ring rotates.

Radial position adjustment

The four small holes (\varnothing 2 mm) on the readhead housing are used for correct radial positioning of the readhead to the ring.

When adjusting the readhead to the MRA7 ring use the two holes further apart (see Installation drawing on page 6).

Use MHA7TACC01 tool for easier adjustment.

When adjusting the readhead to the MRA8 ring use the two holes closer together (see Installation drawing on page 6).

Use MHA8TACC01 tool for easier adjustment.

Installation tolerances (readhead to ring)

Axial (Z) displacement (ride height)	0.2 mm nominal \pm 0.1 mm
Radial (Y) displacement	\pm 0.3 mm
Off center (X) displacement	\pm 0.5 mm
Nonparallell mounting	\pm 0.05 mm

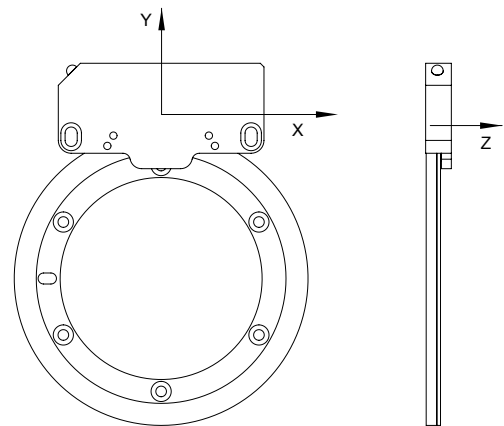

Installation tolerances (ring to shaft)

Ring/shaft fit on MRA7	Worst case accuracy
H7/g6	\pm 0.08°
H7/f7	\pm 0.11°

Ring/shaft fit on MRA8	Worst case accuracy
H7/g6	\pm 0.07°
H7/f7	\pm 0.10°

Accuracy of the encoder system

Precise centering of the ring is key to achieving good overall accuracy.

By minimising the eccentricity of the ring installation (using a gauge) and using a drive shaft with precision bearings, the error can typically be reduced to \pm 0.05° on MRA8 rings or \pm 0.06° on MRA7 rings.

A typical accuracy plot after good installation of MRA8 is shown in the graph on the right.

For highest accuracy options contact RLS.

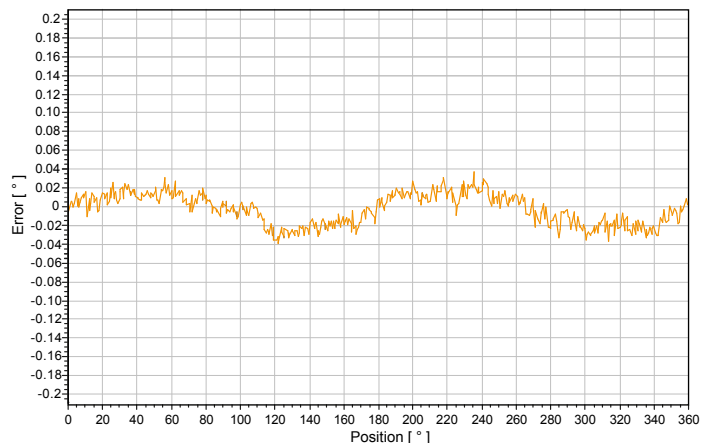

External magnetic field

Principle of operation of any magnetic encoder is sensing changes in the magnetic field of the magnetised ring. External magnetic fields, generated by permanent magnets, electric motors, coils, magnetic brakes, etc. may influence the operation of the encoder. When magnetic field is between 0 mT and 3 mT perpendicularly to the readhead it might affect accuracy. When bigger than 3 mT it temporarily causes the encoder to malfunction. Fields stronger than 50 mT can permanently damage the ring.

Unwanted magnetic fields must be blocked at the source. When this is not possible, encoder can be shielded with ferromagnetic metal plate. The ring can also be used for partial shielding. It is recommended to mount the bottom side of the ring towards the source of the leaking magnetic field and readhead pointing away.

Installation drawing for MHA7 and MRA7

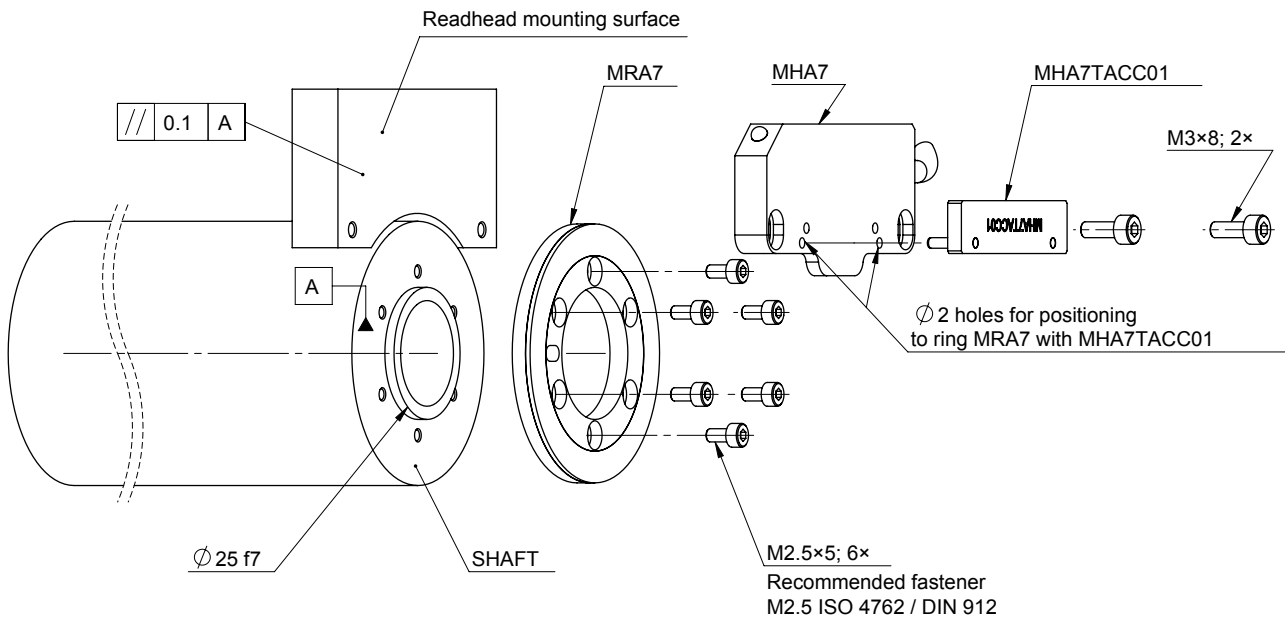

Installation drawing for MHA8 and MRA8

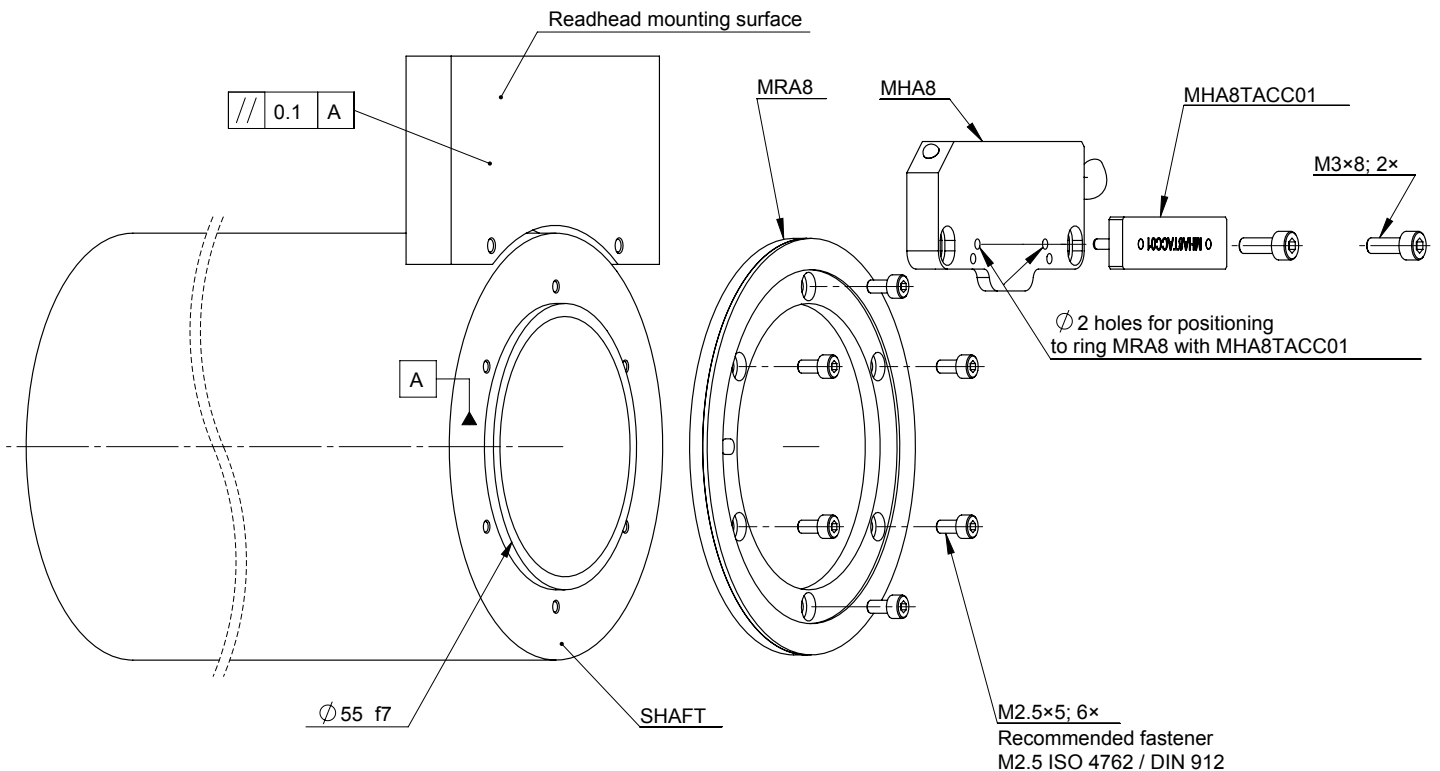

Adjustment procedure

Loosen mounting fasteners (M3) for readhead. Pull readhead away from center of ring. Insert adjustment tool (MHA7ACC01 or MHA8ACC01) or two fasteners (M2x8 mm) into assisting holes. Push readhead towards ring so that assisting pins or fasteners touch outer side of ring. Tighten mounting fasteners. Remove adjustment tool or assisting fasteners. Check operation of encoder.

Electrical connections

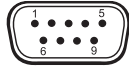

Pin	Wire Colour	Asynchronous serial RS422	PWM	SSI	BiSS	SPI slave
Case	Outer shield	Encoder/machine case (Earth connection)	Encoder/machine case (Earth connection)	Encoder/machine case (Earth connection)	Encoder/machine case (Earth connection)	Encoder/machine case (Earth connection)
1	Inner shield	0 V (GND)	0 V (GND)	0 V (GND)	0 V (GND)	0 V (GND)
2	Red	RX data in+	-	Clock+	MA+	SCK (Clock in)
3	Blue	RX data in-	-	Clock-	MA-	\overline{CS} (Chip Select)
4	Grey	-	Status	-	-	Status *
5	Brown	5 V supply	5 V supply	5 V supply	5 V supply	5 V supply
6	Green	TX data out+	-	Data+	SLO+	MISO (Data out)
7	Yellow	TX data out-	-	Data-	SLO-	-
8	Pink	-	PWM Out	-	-	-
9	White	0 V (GND)	0 V (GND)	0 V (GND)	0 V (GND)	0 V (GND)

* Status signal is available only with SPS option - see SPI interface description.
 For USB interface, the encoder is provided with a certified USB cable and type A connector.
 Wire colors conform to the IEC 60304.

Cable specifications

Not valid for USB cable.

Outer diameter	4.2 mm \pm 0.2 mm
Jacket material	Extruded polyurethane (PUR)
White wire	0.9 mm \pm 0.07 mm diameter, 26 AWG (19 strands REF 6), 0.13 Ω /m
Other wires	0.6 mm \pm 0.07 mm diameter, 30 AWG (7 strands REF 6), 0.35 Ω /m
Power supply lines resistance	0.48 Ω /m at 20 °C
Durability	20 million cycles at 20 mm bend radius
Bend radius	Dynamic 25 mm, static 10 mm (internal radius)
Weight	34 g/m nominal

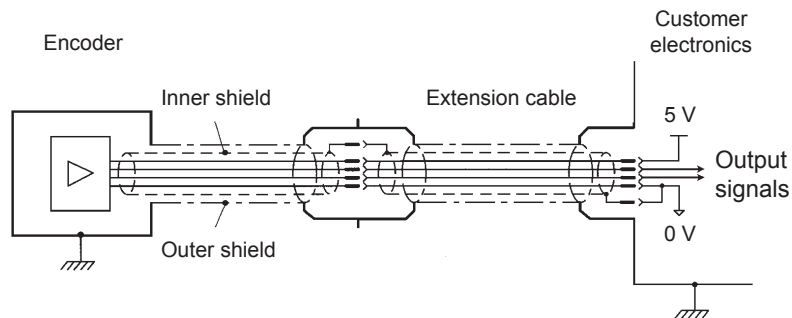

Voltage drop over cable

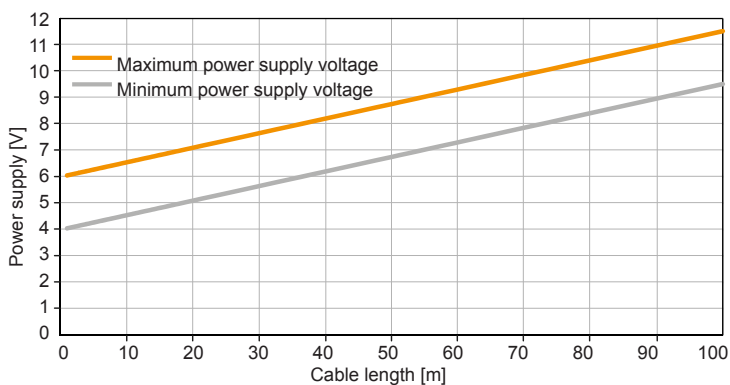

For cables longer than 5 meters input voltage on the cable must be adjusted so the voltage drop is taken into account.

Communication interfaces

Asynchronous serial RS422	
Baud rate	115.2 kbps, 128 kbps, 230.4 kbps, 256 kbps, 500 kbps, 1 Mbps
Data format	8 bits, no parity, 1 stop bit
Update rate	On demand or continuous
Resolution	See table below
Latency	200 µs
PWM	
Base frequency	122.07 Hz, 274.66 Hz, 366.21 Hz, 549.32 Hz, 1098.6 Hz
Update rate	Same as Base frequency
Resolution	16 bits
Latency	200 µs
SSI*	
Maximum clock frequency	500 kHz standard 2.5 MHz with <i>Delay First Clock</i> option on the controller and short cable
Update rate	5 kHz
Resolution	See table below
Latency	200 µs to 400 µs
Timeout (monoflop time)	20 µs
BiSS	
Maximum clock frequency	5 MHz
Maximum request rate	31 kHz (28 kHz Multiturn counter option)
Bandwidth	2.5 kHz max.
Resolution	See table below
Latency	< 10 µs
Timeout (monoflop time)	20 µs
SPI slave*	
Maximum clock frequency	3 MHz at 1.5 m cable length
Update rate	5 kHz
Resolution	16 bits fixed (option S) or up to 20 bits (option A) - see table below
Latency	200 µs to 400 µs
USB	
Resolution	17 bit for type 7 and 18 bit for type 8
Latency	10 ms to 50 ms (computer configuration dependent)

* Slave type interfaces might not be suitable for high-speed closed control loops because of the variable latency time. See "Latency" chapter on page 24 for detailed information.

Available resolutions

Resolution	Ring MRA7	Ring MRA8
Binary	15 bits per revolution	16 bits per revolution
	16 bits per revolution	17 bits per revolution
	17 bits per revolution	18 bits per revolution
	18 bits per revolution *	19 bits per revolution *
	19 bits per revolution *	20 bits per revolution *

* High resolution options may contain noise on the output. These resolutions are suitable for smoother operation of the control loops or averaging to get fine position. Noise margin increases exponentially with increasing ride height between the ring and readhead.

Multiturn counter

On selected digital interfaces additional 16 bit counter is available to count number of shaft turns ($\pm 32,768$ turns). Counting is available only when encoder is powered. During initialization process after switch on multiturn counter is reset to zero. Currently available only via BiSS interface. Please see part numbering on page 25 for ordering information.

Asynchronous serial communication interface over RS422

Encoder identification, position data and temperature are available with request-response type of communication over the asynchronous serial link. There are two unidirectional communication channels, forming a full-duplex bidirectional data link. Every channel consists of a two wire differential twisted-pair connection conforming to the RS422 signalling standard. Data is transmitted MSB first; big-endian order.

Electrical connection

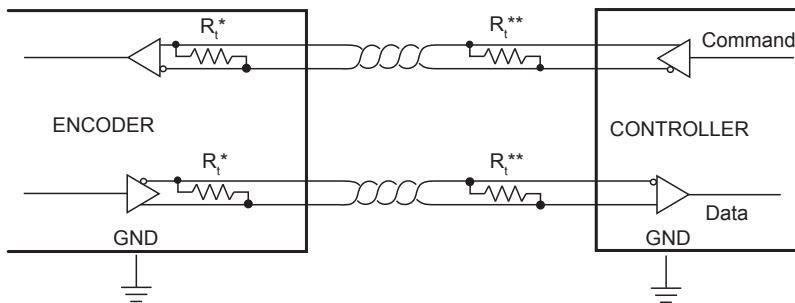

* The Command and Data signals are 5 V RS422 compatible differential pairs with RC termination inside the readhead.

** Termination at the controller is required, if total cable length is longer than 5 m. The nominal impedance of the cable is 120 Ω.

Output protection

Excessive output current and power dissipation caused by faults or by bus contention are prevented by two mechanisms. A foldback current limit on the output stage provides immediate protection against short circuits. In addition, a thermal shutdown circuit forces the driver outputs into a high-impedance state, if the chip temperature becomes too high.

Communication parameters

Character length	8 bits
Parity	None
Stop bits	1
Flow control	None
Repetition rate	5 kHz max. Transmission time lowers this frequency.
Position latency	Fixed at 200 μs between the position acquisition and first start bit sent out. Transmission time is not included here and should be added to calculate the loop time.

Link speed is selectable by the *Communication interface variant* in the part number:

Communication interface variant	A	B	C	D	E	F
Link speed	115.2 kbps	128 kbps	230.4 kbps	256 kbps	500 kbps	1 Mbps

Command set

Command "v" (0x76) - version request

Response - version info and serial number
5 bytes ASCII identification string ("AksIM")
1 byte ASCII space character
8 bytes ASCII serial number
16 bytes ASCII part number
1 byte binary firmware version
1 byte binary communication interface version (5)
1 byte binary ASIC revision
3 bytes ASCII resolution identifier

Command "1" (0x31) - single position data request

Response - position and status, transmitted once
1 byte header 0xEA
3 bytes binary absolute position, big-endian, left aligned
2 bytes encoder status – see below
1 byte constant footer 0xEF

The next request should not be sent sooner than 250 μ s after the end of the previous response from the readhead to allow refreshing of the position data. If request is sent sooner, data will arrive at the end of the refresh cycle.

Command "2" (0x32) - continuous position data request

Response - position and status, transmitted continuously
1 byte constant header 0xEA
3 bytes binary absolute position, big-endian, left aligned
2 bytes encoder status – see below
1 byte constant footer 0xEF

Command "3" (0x33) - request for continuous position data with reduced length

Response - position and status, transmitted continuously
3 bytes binary absolute position, big-endian, left aligned
1 byte detailed encoder status – see below

Command "0" (0x30) - stop

Stop continuous transmission

Command "4" (0x34) - single position data request including velocity information

Response - position, status, and velocity transmitted once
1 byte header 0xEA
3 bytes binary absolute position, big-endian, left aligned, unsigned
2 bytes encoder status - see below
3 bytes binary velocity information, right aligned, signed
1 byte constant footer 0xEF

Velocity resolution: Number of counts per 1 microsecond multiplied by 65536.
Counts per second (CPS) = velocity $\times 10^6 / 2^{16}$
Degrees per second (DPS) = CPS $\times 360 / 2^{20}$ (at 20-bit resolution)

The next request should not be sent sooner than 250 μ s after the end of the previous response from the readhead to allow refreshing of the position data. If request is sent sooner, data will arrive at the end of the refresh cycle.

Command "t" (0x74) - temperature request

Response - temperature of the encoder
1 byte signed binary number - temperature of the sensor in $^{\circ}$ C

Accuracy of the readings is ± 3 $^{\circ}$ C

This function is available with firmware version 30 and higher (see command "v" for firmware version).

Structure of data packet

Encoder status (two bytes):	
b15 : b10	Reserved, always zero
General status	
b9	Error. If bit is set, position is not valid.
b8	Warning. If bit is set, encoder is near operational limits. Position is valid. Resolution and / or accuracy might be lower than specified.
<p>Error and Warning bits can be set at the same time; in this case Error bit has priority. The colour of the LED on the readhead housing indicates the value of the General status bits: Red = Error, Orange = Warning, Green = Normal operation, No light = no power supply. The warning or error status is more closely defined by the Detailed status bits.</p>	
Detailed status	
b7	Warning - Signal amplitude too high. The readhead is too close to the ring or an external magnetic field is present.
b6	Warning - Signal amplitude low. The distance between the readhead and the ring is too large.
b5	Error - Signal lost. The readhead is out of alignment with the ring or the ring is damaged.
b4	Warning - Temperature. The readhead temperature is out of specified range.
b3	Error - Power supply error. The readhead power supply voltage is out of specified range.
b2	Error - System error. Malfunction inside the circuitry or inconsistent calibration data is detected. To reset the System error bit try to cycle the power supply while the rise time is shorter than 20 ms.
b1	Error - Magnetic pattern error. A stray magnetic field is present or metal particles are present between the readhead and the ring or radial positioning between the readhead and the ring is out of tolerances.
b0	Error - Acceleration error. The position data changed too fast. A stray magnetic field is present or metal particles are present between the readhead and the ring.

PWM - Pulse width modulation interface

The PWM communication interface consists of two digital signals: the Status signal and the PWM Out signal. It is 3.3 V TTL compatible.

Electrical connection

The Status and PWM Out signals are 3.3 V TTL compatible. These signal outputs have weak ESD protection, therefore the readhead must be handled with additional care in ESD controlled environment and with ESD protection.

Maximum current sourced from or sunk into signal lines should not exceed 20 mA.

Status signal

The Status signal indicates the current status of the encoder. The Status signal is high for normal operation and valid position information. The low state of the Status signal indicates an error state of the encoder which can be caused by:

- Operation outside the installation tolerances
- Invalid or damaged magnetisation of the ring
- Sensor malfunction
- System error
- No power supply

When the Status signal is low, the PWM Out signal is low and no pulses are output.

The encoder position is latched on the rising edge of the PWM Out signal. The Status signal should also be checked at the rising edge of the PWM Out signal. If the Status signal changes during the PWM period, it does not affect the currently transmitted position information.

PWM Out signal

The PWM Out is a pulse width modulation output with 16-bit resolution whose duty cycle is proportional to the measured position. The change of the pulse width by PW_{min} corresponds to a change in position by one count (change in angle for $360^\circ / 65536 \approx 0.00549^\circ$).

PWM Out signal timing diagram

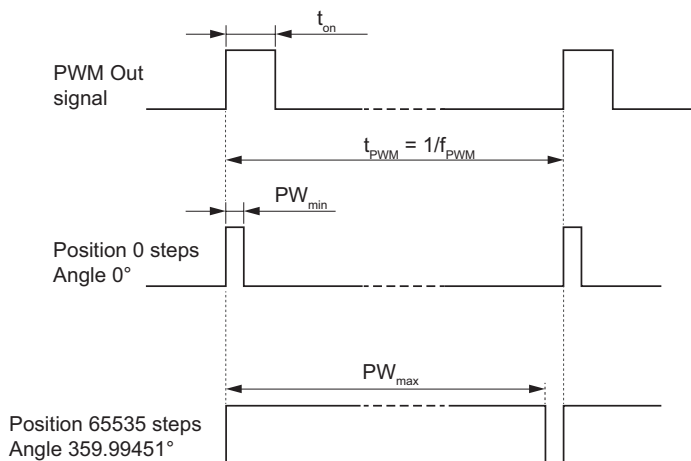

Communication parameters

Communication interface variant in the part number defines the PWM frequency and all other dependent parameters.

Parameter	Symbol	Communication interface variant					Unit	Note
		A	B	C	D	E		
PWM frequency	f_{PWM}	122.07	274.66	366.21	549.32	1098.63	Hz	
Signal period	t_{PWM}	8192	3640.89	2730.67	1820.44	910.22	μs	
Minimum pulse width	PW_{min}	0.125	0.0556	0.0417	0.0278	0.0139	μs	Position 0 (Angle 0°)
Maximum pulse width	PW_{max}	8191.875	3640.83	2730.63	1820.42	910.21	μs	Positions 65534 and 65535 *
Min. counter frequency	f_{CINTR}	8	18	24	36	72	MHz	Receiving counter frequency
Resolution		16 Bit	16 Bit	16 Bit	16 Bit	16 Bit		Fixed; resolution in part number must be set as "16B"

* Note that positions 65534 and 65535 (Angle 359.98901° and 359.99451°) result in the same pulse width PW_{max} .

$$Position [counts] = \frac{t_{on} \times 65536}{t_{PWM}} - 1$$

$$Position [^\circ] = \frac{(t_{on} - PW_{min}) \times 360^\circ}{t_{PWM}}$$

SSI - Synchronous serial interface

The encoder position, in up to 20 bit natural binary code, and the encoder status are available through the SSI protocol. The position data is left aligned. After the position data there are two general status bits followed by the detailed status information.

Electrical connection

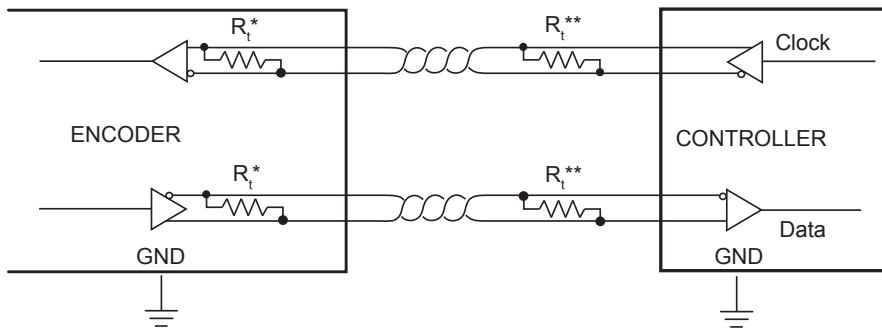

* The Clock and Data signals are 5 V RS422 compatible differential pairs with RC termination inside the readhead.

** Termination at the controller is required, if total cable length is longer than 5 m. The nominal impedance of the cable is 120 Ω .

Output protection

Excessive output current and power dissipation caused by faults or by bus contention are prevented by two mechanisms. A foldback current limit on the output stage provides immediate protection against short circuits. In addition, a thermal shutdown circuit forces the driver outputs into a high-impedance state, if the chip temperature becomes too high.

SSI timing diagram

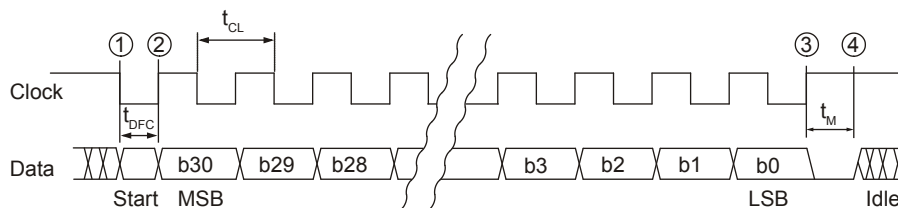

The controller interrogates the readhead for its position and status data by sending a pulse train to the Clock input. The Clock signal always starts from high. The first falling edge ① latches the last position data available and on the first rising edge ② the most significant bit (MSB) of the position is transmitted to the Data output. The Data output should then be latched on the following falling edge. On subsequent rising edges of the Clock signal the next bits are transmitted. If time between ① and ② is extended for additional 1 μ s, then maximum clock frequency limit is 2.5 MHz instead of 500 kHz. This function is called "Delay First Clock" and must be supported by the controller to which the encoder is connected.

After the transmission of the last bit ③ the Data output goes to low. When the t_M time expires the Data output is undefined ④. The Clock signal must remain high for at least t_M before the next reading can take place.

While reading the data the period t_{CL} must always be less than t_M . However, reading the encoder position can be terminated at any time by setting the Clock signal to high for the duration of t_M .

To allow updating of the position data at least t_B should pass between two subsequent readings. If the reading request arrives earlier than t_B after the previous reading, the encoder position will not be updated.

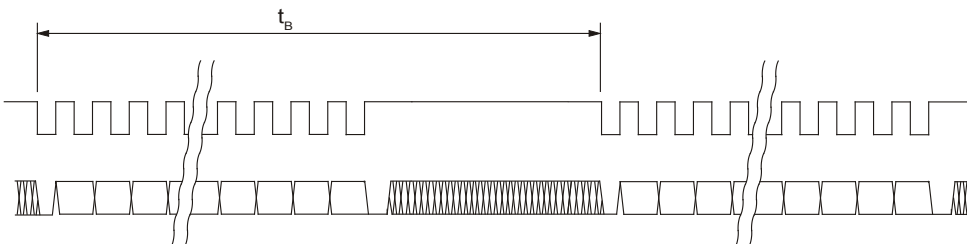

The power supply must be applied at least 10 ms before the clock sequence is being sent to the encoder.

Data sheet
MHAD01_09

Maximum frequency

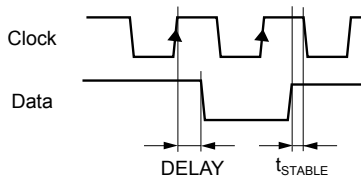

The readhead needs 170 ns to respond to incoming clocks (t_{RESP}). Change on Data signal is delayed for 170 ns after the rising edge on Clock line. Additional delay is caused by the time the signal needs to propagate through cable to the readhead and back (t_{PROP}). This delay is typically 14 ns per 1 meter of cable. Data signal must be stable for at least 10 % of the clock period length before the value is latched.

The clock frequency must be reduced with a longer cable. Total cable length must be taken into account, from the encoder to the receiver.

$$t_{DELAY} = t_{RESP} + t_{PROP} \times \text{cable length}$$

Frequency derating versus cable length:

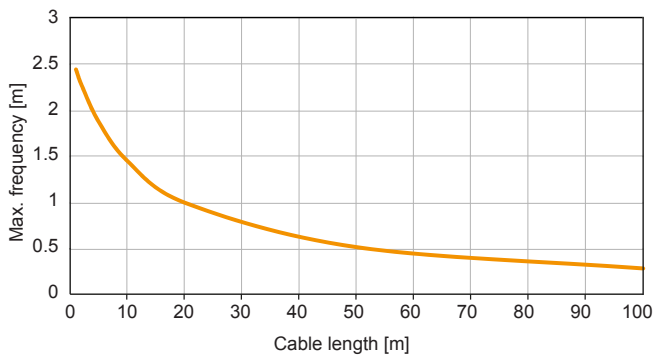

Communication parameters

Parameter	Symbol	Min	Typ	Max
Delay first clock	t_{DFC}	1 μ s		10 μ s
Clock period	t_{CL}	2 μ s		20 μ s
Clock frequency	f_{CL}	50 kHz		500 kHz (2.5 MHz *)
Monoflop time	t_M		20 μ s	
Repetition rate	t_B	200 μ s		
Readhead response delay	t_{RESP}		170 ns	
Cable propagation delay	t_{PROP}		14 ns/m	

* With *Delay First Clock* function on the controller.

Start bit and idle line value are defined by the *Communication interface variant*.

Communication interface variant	Line state selection	Usage
A	Start bit = 0; idle line = 0	Not recommended for new design
B	Start bit = 1; idle line = 1	Standard

Structure of data packet

Bit	b30 : b11	b10 : b9	b8 : b1	b0
Data length	20 bits	2 bits	8 bits	1 bit
Meaning	Encoder position	General status	Detailed status	Reserved

Encoder position

b30 : b11 Encoder position – Left aligned, MSB first, LSB last. If the encoder resolution is lower than 20 bits, the last few bits of the encoder position, which are not used, are set to zero.

General status

b10 Error bit. If set, the position is not valid.

b9 Warning bit. If set, the encoder operational is close to its limits. The position is still valid, but the resolution and/or accuracy might be out of specification.

The Error and Warning bits can be set at the same time, in this case the Error bit has priority.
 The colour of the LED on the readhead housing indicates the value of the General status bits:
Red = Error, **Orange** = Warning, **Green** = Normal operation, No light = No power supply.
 The warning or error status is more closely defined by the Detailed status bits.

Detailed status

b8 Warning - Signal amplitude too high. The readhead is too close to the ring or an external magnetic field is present.

b7 Warning - Signal amplitude low. The distance between the readhead and the ring is too large.

b6 Error - Signal lost. The readhead is out of alignment with the ring or the ring is damaged.

b5 Warning - Temperature. The readhead temperature is out of specified range.

b4 Error - Power supply error. The readhead power supply voltage is out of specified range.

b3 Error - System error. Malfunction inside the circuitry or inconsistent calibration data is detected.
 To reset the System error bit try to cycle the power supply while the rise time is shorter than 20 ms.

b2 Error - Magnetic pattern error. A stray magnetic field is present or metal particles are present between the readhead and the ring or radial positioning between the readhead and the ring is out of tolerances.

b1 Error - Acceleration error. The position data changed too fast. A stray magnetic field is present or metal particles are present between the readhead and the ring.

b0 Reserved, always zero.

BiSS-C interface

The encoder position, in up to 20 bit natural binary code, and the encoder status are available through the BiSS-C protocol. The position data is left aligned. After the position data there are two status bits (active low) followed by CRC (inverted).

BiSS is implemented for point-to-point operation; multiple slaves are not supported.

Communication is unidirectional, the readhead is not user programmable and custom parameters cannot be stored into the readhead.

Electrical connection

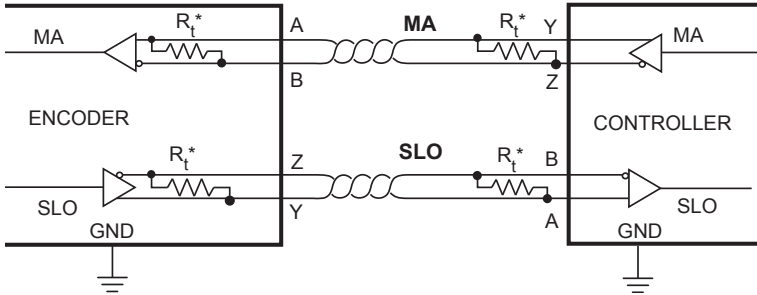

Signals	
MA	Master clock. Max clock frequency is 5 MHz.
SLO	Slave out. Data is output on rising edge on SCK. Data is valid on the falling edge of SCK signal.

* The MA and SLO lines are 5 V RS422 compatible differential pairs. The termination resistor on the MA line is integrated inside the encoder. The termination on the end of the SLO line at the controller end is required, if the total cable length is longer than 5 m. The nominal impedance of the cable is 120 Ω.

Output protection

Excessive output current and power dissipation caused by faults or by bus contention are prevented by two mechanisms. A foldback current limit on the output stage provides immediate protection against short circuits. In addition, a thermal shutdown circuit forces the driver outputs into a high-impedance state, if the chip temperature becomes too high.

BiSS-C timing diagram

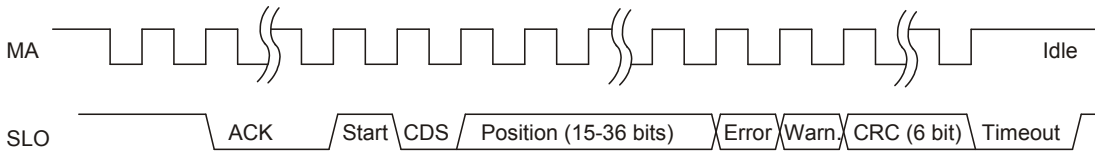

MA is idle high. Communication is initiated with first falling edge.

The encoder responds by setting SLO low on the second rising edge on MA. ACK length is 12 bits.

When the encoder is ready for the next request cycle it indicates this to the master by setting SLO high.

The absolute position and CRC data is in binary format and sent MSB first.

Multicycle data is not implemented, therefore CDS bit is always zero.

Cable length compensation

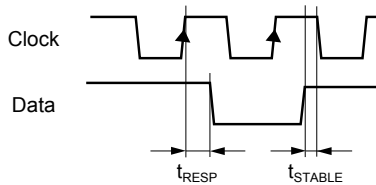

The readhead needs 170 ns to respond to incoming clocks (t_{RESP}). Change on Data signal is delayed for 170 ns after the rising edge on Clock line. Additional delay is caused by the time the signal needs to propagate through cable to the readhead and back (t_{PROP}). This delay is typically 14 ns per 1 meter of cable. Total cable length must be taken into account, from the encoder to the receiver.

$$t_{DELAY} = t_{RESP} + t_{PROP} \times \text{cable length}$$

The data signal must be stable before the value is latched. Therefore with a cable longer than 1 meter and a clock frequency higher than 2.5 MHz this delay must be compensated for in the receiver (controller) to which the encoder is connected.

Status bits

Type	Value 0	Value 1	Possible reason for failure
Error	Position data is invalid.	OK	Error bit is active low. If low, the position is not valid.
Warning	Position data is valid.	OK	Warning bit is active low. If low, the encoder operation is close to its limits. The position is still valid but the resolution and/or accuracy might be out of specification.

Communication parameters

Communication interface variant in the part number defines the functionality of the encoder.

Communication interface variant	Parameter	Value
H	MA frequency	Max. 5 MHz

Parameter	Symbol	Worst case
Latency		<10 μ s
Bandwidth *		2.5 kHz
Maximum request rate		31 kHz (28 kHz Multiturn counter option)
Timeout		20 μ s
Readhead response delay	t_{RESP}	170 ns
Cable propagation delay	t_{PROP}	14 ns/m

* Bandwidth parameter is mechanical bandwidth. AksIM samples at 5 kHz therefore any mechanical changes that are appearing faster than 2.5 kHz are not detectable on the output (Nyquist theorem). If request for position comes faster than sampling frequency, AksIM encoder recalculates the position at the time of request based on current ring velocity.

Data packet description

Data packet length depends on the resolution and can be from 24 to 44 bits long. It consists of 16 bits for the multiturn counter (if selected) and 15 to 20 bits of Position selected by (resolution), followed by 2 Status bits and 6 CRC bits (see table below).

Resolution	Multiturn counter	Position	Status		CRC (inverted)
			Error	Warning	
15B	0 bits	15 bits	1 bit	1 bit	6 bits
16B		16 bits			
17B		17 bits			
18B		18 bits			
19B		19 bits			
20B		20 bits			
15M	16 bits	15 bits	1 bit	1 bit	6 bits
16M		16 bits			
17M		17 bits			
18M		18 bits			
19M		19 bits			
20M		20 bits			

Example: 18 bits of position + 2 status bits + 6 bits CRC = 26 bits long data packet.

Polynomial for CRC calculation of position, error and warning data is: $x^6 + x^1 + 1$. Represented also as 0x43. It is inverted and transmitted MSB first.

Example of calculation routine for 6-bit CRC can be found in Appendix 2 of this document.

For more information regarding BiSS protocol see www.biss-interface.com.

SPI - Serial peripheral interface (slave mode)

The SPI interface is designed for communication with nearby devices.

Electrical connection

All data signals are 3.3 V LVTTTL. Inputs are 5 V tolerant.

Maximum current sourced from or sunk into signal lines should not exceed 20 mA.

Signal	Description
\overline{CS}	Active low. \overline{CS} line is used for synchronisation between master and slave devices. During communication it must be held low. Idle is high. Rising edge on \overline{CS} signal resets the SPI interface.
SCK	Clocks out the data on rising edge. Max frequency 3 MHz at 1.5 m cable length.
MISO	Data is output on rising edge on SCK after \overline{CS} low. Data is valid on the falling edge of SCK signal. During $\overline{CS}=1$ MISO line is in high-Z mode.
Status	Indicates normal operation (only available with S option).

Communication parameters

Communication interface variant in the part number defines the SPI interface type and all dependent parameters.

Communication interface variant	Description	Parameter	Value
S	SPI slave - simple mode	Resolution	Fixed - resolution in part number must be set as "16B"
		Status	Error status available on a separate wire
		Data length	16 bit data packet - position only
A	SPI slave - advanced mode	Resolution	Selectable (see part numbering)
		Status	All status bits are available through the SPI
		Data length	40 bit data packet - position, status, CRC
T	SPI slave - advanced mode with timestamp	Resolution	Selectable (see part numbering)
		Status	All status bits are available through the SPI
		Data length	56 bit data packet - position, status, timestamp, CRC

Parameter	Symbol	Min	Typ	Max	Note
Clock frequency	f_{CLK}	1 Hz		3 MHz	Max frequency with 1.5 m cable
Time after \overline{CS} low to first SCK rising edge	t_S	2 μ s			
Time after last SCK falling edge to \overline{CS} high	t_H	1 μ s			
\overline{CS} high time	t_R	8 μ s			Time to complete SPI reset
Read repetition rate	f_{REP}			5 kHz	If higher, the same position data might be transmitted twice

SPI slave - simple mode (variant S)

Structure of data packet

Data packet is 16 bits long. MSB first. Left aligned. Position only, no status bits. Only 16-bit resolution available. Repetition of reading is maximum 5000 times per second. If higher, it is possible to read the same position data twice.

Status signal

The Status signal indicates the current status of the encoder. The Status signal is high with normal operation and valid position information. The low state of the Status signal indicates an error state of the encoder which can be caused by:

- Operation outside the installation tolerances
- Invalid or corrupted magnetisation of the ring
- Sensor malfunction
- System error
- No power supply

When the Status signal is low, the data read through the SPI interface is invalid. The Status signal should be checked at the first rising edge of the SCK signal. If the Status signal changes during the data transmission, it does not affect the currently transmitted position information.

SPI slave timing diagram (variant S)

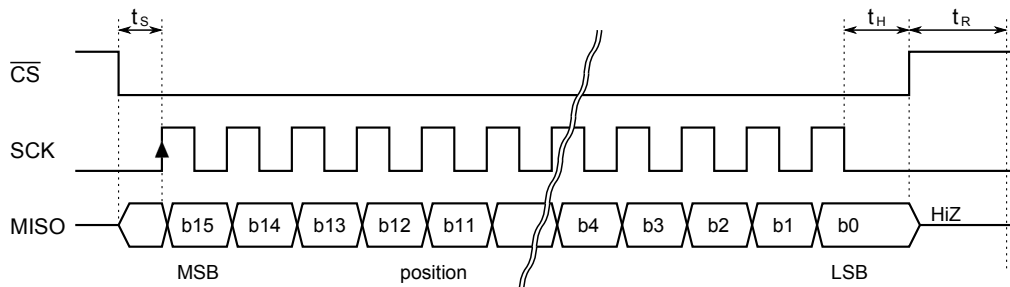

Data sheet
MHAD01_09

SPI slave - advanced mode (variant A)

Structure of data packet

Data packet is 40 bits long. MSB first. Position data is left aligned.

Repetition of reading is maximum 5000 times per second. If higher, it is possible to read the same position data twice.

Bit	b31 : b12	b11 : b10	b9 : b2	b1 : b0	c7 : c0
Data length	20 bits	2 bits	8 bits	2 bits	8 bits
Meaning	Encoder position	General status	Detailed status	Reserved always 1	CRC

Encoder position

b31 : b12 Encoder position, left aligned, MSB first. If the encoder resolution is lower than 20 bits, the last few bits of the encoder position, which are not used, are set to zero.

General status

b11 Error. If bit is set, position is not valid.

b10 Warning. If bit is set, encoder is near operational limits. Position is valid. Resolution and / or accuracy might be lower than specified.

Error and Warning bits can be set at the same time; in this case Error bit has priority.

The color of the LED on the readhead housing indicates the value of the General status bits:

Red = Error, Orange = Warning, Green = Normal operation, No light = no power supply.

The warning or error status is more closely defined by the Detailed status bits.

Detailed status

b9 Warning - Signal amplitude too high. The readhead is too close to the ring or an external magnetic field is present.

b8 Warning - Signal amplitude low. The distance between the readhead and the ring is too large.

b7 Error - Signal lost. The readhead is out of alignment with the ring or the ring is damaged.

b6 Warning - Temperature. The readhead temperature is out of specified range.

b5 Error - Power supply error. The readhead power supply voltage is out of specified range.

b4 Error - System error. Malfunction inside the circuitry or inconsistent calibration data is detected. To reset the System error bit try to cycle the power supply while the rise time is shorter than 20 ms.

b3 Error - Magnetic pattern error. A stray magnetic field is present or metal particles are present between the readhead and the ring or radial positioning between the readhead and the ring is out of tolerances.

b2 Error - Acceleration error. The position data changed too fast. A stray magnetic field is present or metal particles are present between the readhead and the ring.

CRC

c7 : c0 CRC check with polynomial 0x97 - see Appendix 1 of this document.

Status signal

The Status signal is not available in advanced mode.

SPI slave timing diagram (variant A)

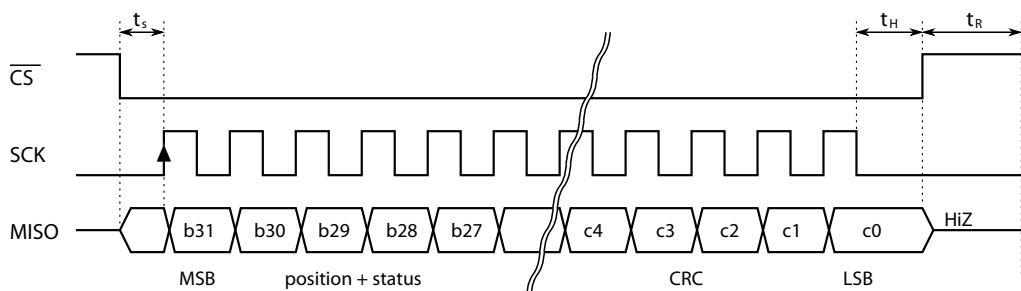

SPI slave - advanced mode with timestamp (variant T)

Structure of data packet

Data packet is 56 bits long. MSB first. Position data is left aligned.

Repetition of reading is maximum 5000 times per second. If higher, it is possible to read the same position data twice.

Bit	b31 : b12	b11 : b10	b9 : b2	b1 : b0	t15 : t0	c7 : c0
Data length	20 bits	2 bits	8 bits	2 bits	16 bits	8 bits
Meaning	Encoder position	General status	Detailed status	Reserved always 1	Timestamp	CRC

Encoder position

b31 : b12 Encoder position, left aligned, MSB first. If the encoder resolution is lower than 20 bits, the last few bits of the encoder position, which are not used, are set to zero.

General status

b11 Error. If bit is set, position is not valid.

b10 Warning. If bit is set, encoder is near operational limits. Position is valid. Resolution and / or accuracy might be lower than specified.

Error and Warning bits can be set at the same time; in this case Error bit has priority.

The color of the LED on the readhead housing indicates the value of the General status bits:

Red = Error, Orange = Warning, Green = Normal operation, No light = no power supply.

The warning or error status is more closely defined by the Detailed status bits.

Detailed status

b9 Warning - Signal amplitude too high. The readhead is too close to the ring or an external magnetic field is present.

b8 Warning - Signal amplitude low. The distance between the readhead and the ring is too large.

b7 Error - Signal lost. The readhead is out of alignment with the ring or the ring is damaged.

b6 Warning - Temperature. The readhead temperature is out of specified range.

b5 Error - Power supply error. The readhead power supply voltage is out of specified range.

b4 Error - System error. Malfunction inside the circuitry or inconsistent calibration data is detected. To reset the System error bit try to cycle the power supply while the rise time is shorter than 20 ms.

b3 Error - Magnetic pattern error. A stray magnetic field is present or metal particles are present between the readhead and the ring or radial positioning between the readhead and the ring is out of tolerances.

b2 Error - Acceleration error. The position data changed too fast. A stray magnetic field is present or metal particles are present between the readhead and the ring.

Timestamp

t15 : t0 Time between latch of mechanical position and \overline{CS} falling edge in μsec .

CRC

c7 : c0 CRC check with polynomial 0x97 - see Appendix 1 of this document.

Status signal

The Status signal is not available in this mode.

SPI slave timing diagram (variant T)

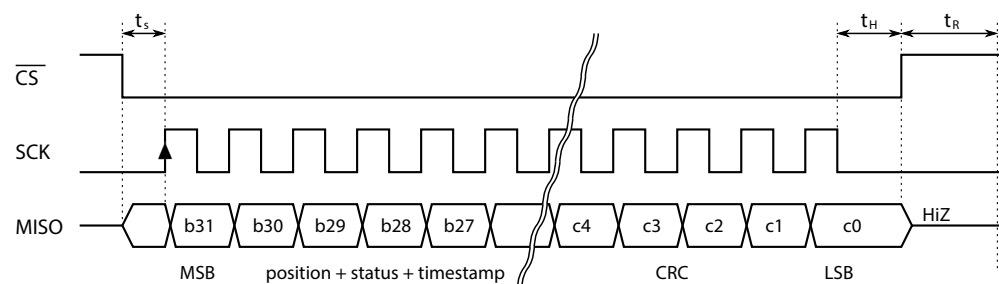

USB - Universal serial bus

Encoder identification, position data and temperature are available with request-response type of communication over the Universal Serial Bus (USB). The encoder is recognised by a computer as a virtual COM port. This type of communication can be used for direct connection to a measuring station powered by an (industrial) PC. Supported operating systems: 32-bit and 64-bit Windows (XP, Vista, 7 and 8/10), Linux and Mac OS X. The encoder may not be correctly recognised, if plugged into a USB 3.0 port. Please use USB 2.0 port or USB hub. The encoder can be accessed from any software that supports connection to a virtual COM port (for example C++, Delphi, Labview, etc.).

Electrical connection

USB cable with A type USB connector is provided. Cable length is 1.8 meter. It can be extended to 5 meters with certified USB extension cords capable of carrying higher supply currents (200 mA minimum).

USB drivers

USB drivers for the virtual COM port for Windows are available on the RLS website: www.rls.si/AksIM.

Encoder should be automatically recognized on the Linux system and Mac OS X. It uses the »Communication Device Class driver (CDC)«. VID = 0483 & PID = 5740

Communication parameters

Settings of baud rate, character length and parity bits do not affect the communication. Any value can be used.

Communication interface variant does not affect the USB interface. Use default value "B".

Command set

Command "v" (0x76) - version request

Response - version info and serial number
5 bytes ASCII identification string ("AksIM")
1 byte ASCII space character
8 bytes ASCII serial number
16 bytes ASCII part number
1 byte binary firmware version
1 byte binary communication interface version (5)
1 byte binary ASIC revision
3 bytes ASCII resolution identifier

Command "1" (0x31) - single position data request

Response - position and status, transmitted once
1 byte header 0xEA
3 bytes binary absolute position, big-endian, left aligned
2 bytes encoder status – see below
1 byte constant footer 0xEF

The next request should not be sent sooner than 250 µs after the end of the previous response from the readhead to allow refreshing of the position data. If request is sent sooner, data will arrive at the end of the refresh cycle.

Command "2" (0x32) - continuous position data request

Response - position and status, transmitted continuously
1 byte constant header 0xEA
3 bytes binary absolute position, big-endian, left aligned
2 bytes encoder status – see below
1 byte constant footer 0xEF

Command "3" (0x33) - request for continuous position data with reduced length

Response - position and status, transmitted continuously
3 bytes binary absolute position, big-endian, left aligned
1 byte detailed encoder status – see below

Command "0" (0x30) - stop

Stop continuous transmission

Command "t" (0x74) - temperature request

Response - temperature of the encoder
1 byte signed binary number - temperature of the sensor in °C

Accuracy of the readings is ±3 °C

This function is available with firmware version 30 and higher (see command "v" for firmware version).

Structure of data packet

Encoder status (two bytes):	
b15 : b10	Reserved; always zero
General status	
b9	Error. If bit is set, position is not valid.
b8	Warning. If bit is set, encoder is near operational limits. Position is valid. Resolution and/or accuracy might be lower than specified.
<p>Error and Warning bits can be set at the same time; in this case Error bit has priority. The color of the LED on the readhead housing indicates the value of the General status bits: Red = Error, Orange = Warning, Green = Normal operation, No light = no power supply. The warning or error status is more closely defined by the Detailed status bits.</p>	
Detailed status	
b7	Warning - Signal amplitude too high. The readhead is too close to the ring or an external magnetic field is present.
b6	Warning - Signal amplitude low. The distance between the readhead and the ring is too large.
b5	Error - Signal lost. The readhead is out of alignment with the ring or the ring is damaged.
b4	Warning - Temperature. The readhead temperature is out of specified range.
b3	Error - Power supply error. The readhead power supply voltage is out of specified range.
b2	Error - System error. Malfunction inside the circuitry or inconsistent calibration data is detected. To reset the System error bit try to cycle the power supply while the rise time is shorter than 20 ms.
b1	Error - Magnetic pattern error. A stray magnetic field is present or metal particles are present between the readhead and the ring or radial positioning between the readhead and the ring is out of tolerances.
b0	Error - Acceleration error. The position data changed too fast. A stray magnetic field is present or metal particles are present between the readhead and the ring.

Latency on Asynchronous serial communication

Readhead has its internal cycle of acquiring position that is running at 5 kHz ($\pm 10\%$). One cycle takes 200 μs . This does not depend on the request frequency.

Controller sends the request. If the request arrives into the readhead just after new cycle has started, it will take 200 μs for the new position to be ready. It is transmitted to controller, always at the end of the cycle. In this case there will be 200 μs of delay between request and answer (transmission time is not taken into account).

If the request arrives into the readhead just before the end of the cycle, the position is just ready and response will be transmitted instantly. Position was acquired 200 μs ago at the beginning of the cycle.

Second mode is continuous transmission after every cycle. In this mode there is no need to query the encoder for position but it sends it immediately when it is ready.

When the controller receives the first bit of the data position it is 200 μs old. This time is constant ($\pm 10\%$). The additional delay is due to time needed to complete the data transmission. This varies depending on the selected bit-rate.

(Per special request timing information and/or speed can be provided in the same data packet as position.)

Latency on other slave type interfaces (SSI, SPI slave)

All interfaces transmit the last valid data available.

Internal cycle of the encoder is 200 μs . This is the delay from the time when the mechanical position is latched by the sensor to the time when the data is ready to be transmitted over the interface.

If the request comes right after the data is ready, latency will be 200 μs .

If request comes just before the new data will be calculated, then latency is 400 μs .

For example:

At $t = 0 \mu\text{s}$ the physical position is latched but position data is not yet calculated. It will be available at 200 μs .

If the request comes at $t = 1 \mu\text{s} - 199 \mu\text{s}$, the last available data will be sent - the one from previous cycle when position was latched at $t = -200 \mu\text{s}$.

Latency on BiSS

BiSS uses a different approach and calculation so the request rate can be higher than 5 kHz. Typically, request rate can be up to 30 kHz. Position is latched at the first falling edge on the MA (clock) line and calculated instantly, therefore latency is shorter than 10 μs .

Readhead part numbering

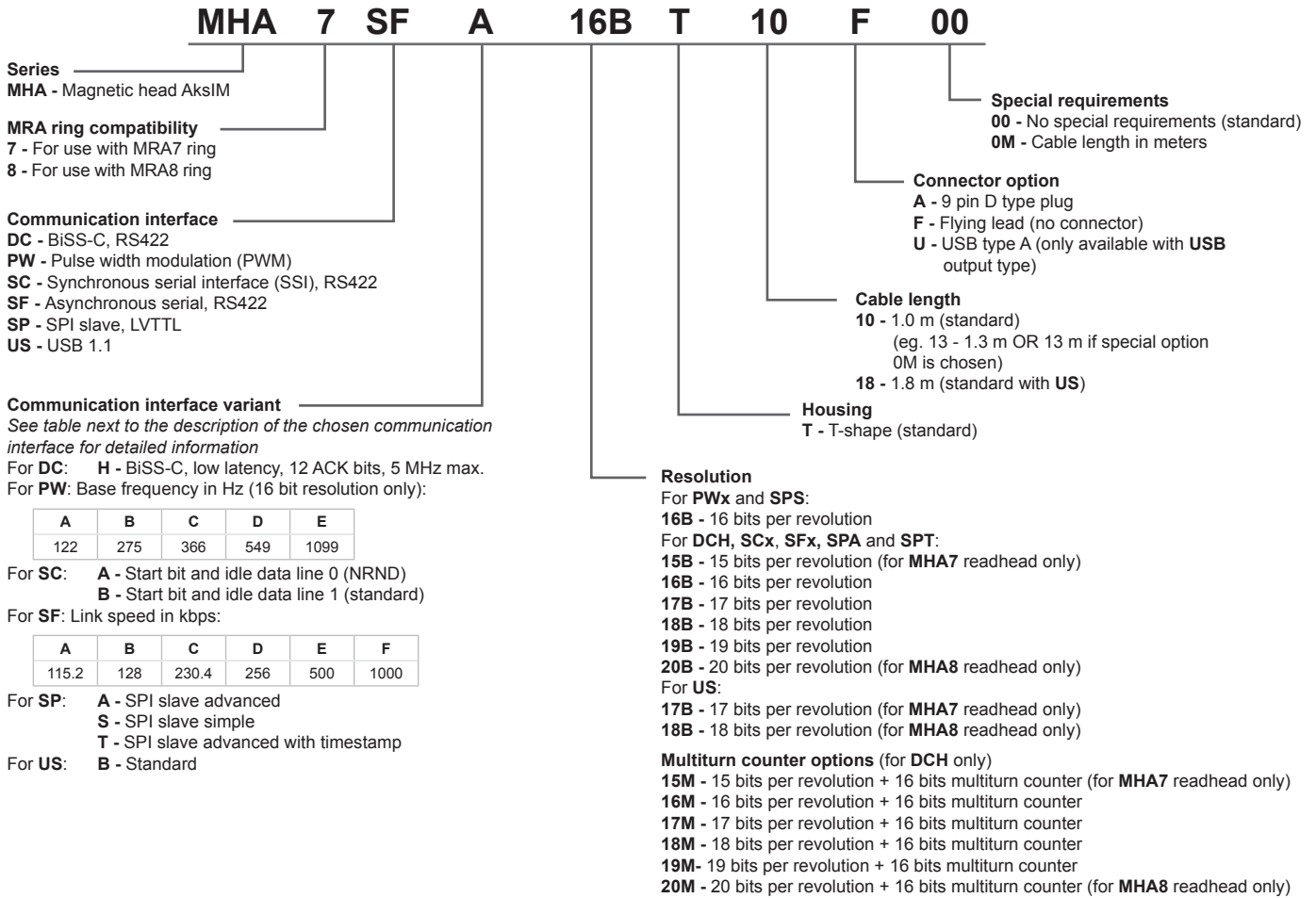

Ring part numbering

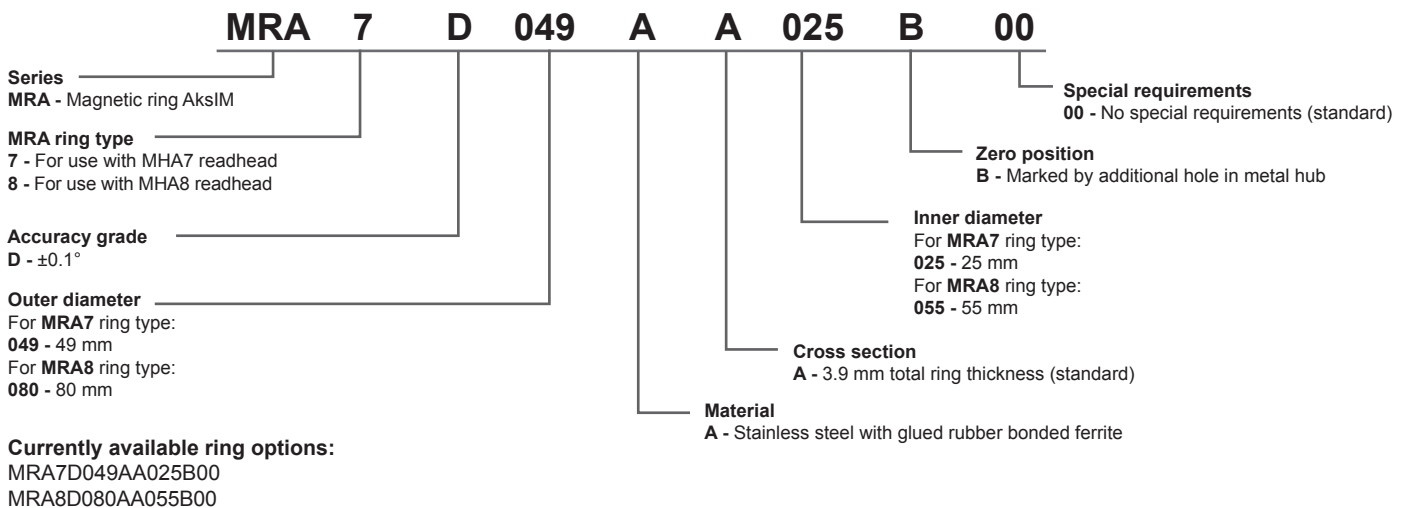

Accessories

- MHA7TACC01 Alignment tool for MHA7 readhead / MRA7 ring radial positioning
MHA8TACC01 Alignment tool for MHA8 readhead / MRA8 ring radial positioning

Appendix 1 - 8-bit CRC calculation with 0x97 polynome

Some of the communication interfaces offer a CRC value to check the correctness of the data read from the encoder. This chapter gives an example of the CRC calculation on the receiver side. The CRC calculation must always be done over the complete set of data including all the reserved bits. The polynomial for the CRC calculation is $P(x) = x^8 + x^7 + x^4 + x^2 + x^1 + 1$, also represented as 0x97.

Code example:

```
//poly = 0x97
static u8 tableCRC [256] = {
    0x00, 0x97, 0xB9, 0x2E, 0xE5, 0x72, 0x5C, 0xCB, 0x5D, 0xCA, 0xE4, 0x73, 0xB8, 0x2F, 0x01, 0x96,
    0xBA, 0x2D, 0x03, 0x94, 0x5F, 0xC8, 0xE6, 0x71, 0xE7, 0x70, 0x5E, 0xC9, 0x02, 0x95, 0xBB, 0x2C,
    0xE3, 0x74, 0x5A, 0xCD, 0x06, 0x91, 0xBF, 0x28, 0xBE, 0x29, 0x07, 0x90, 0x5B, 0xCC, 0xE2, 0x75,
    0x59, 0xCE, 0xE0, 0x77, 0xBC, 0x2B, 0x05, 0x92, 0x04, 0x93, 0xBD, 0x2A, 0xE1, 0x76, 0x58, 0xCF,
    0x51, 0xC6, 0xE8, 0x7F, 0xB4, 0x23, 0x0D, 0x9A, 0x0C, 0x9B, 0xB5, 0x22, 0xE9, 0x7E, 0x50, 0xC7,
    0xEB, 0x7C, 0x52, 0xC5, 0x0E, 0x99, 0xB7, 0x20, 0xB6, 0x21, 0x0F, 0x98, 0x53, 0xC4, 0xEA, 0x7D,
    0xB2, 0x25, 0x0B, 0x9C, 0x57, 0xC0, 0xEE, 0x79, 0xEF, 0x78, 0x56, 0xC1, 0x0A, 0x9D, 0xB3, 0x24,
    0x08, 0x9F, 0xB1, 0x26, 0xED, 0x7A, 0x54, 0xC3, 0x55, 0xC2, 0xEC, 0x7B, 0xB0, 0x27, 0x09, 0x9E,
    0xA2, 0x35, 0x1B, 0x8C, 0x47, 0xDD, 0xFE, 0x69, 0xFF, 0x68, 0x46, 0xD1, 0x1A, 0x8D, 0xA3, 0x34,
    0x18, 0x8F, 0xA1, 0x36, 0xFD, 0x6A, 0x44, 0xD3, 0x45, 0xD2, 0xFC, 0x6B, 0xA0, 0x37, 0x19, 0x8E,
    0x41, 0xD6, 0xF8, 0x6F, 0xA4, 0x33, 0x1D, 0x8A, 0x1C, 0x8B, 0xA5, 0x32, 0xF9, 0x6E, 0x40, 0xD7,
    0xFB, 0x6C, 0x42, 0xD5, 0x1E, 0x89, 0xA7, 0x30, 0xA6, 0x31, 0x1F, 0x88, 0x43, 0xD4, 0xFA, 0x6D,
    0xF3, 0x64, 0x4A, 0xDD, 0x16, 0x81, 0xAF, 0x38, 0xAE, 0x39, 0x17, 0x80, 0x4B, 0xDC, 0xF2, 0x65,
    0x49, 0xDE, 0xF0, 0x67, 0xAC, 0x3B, 0x15, 0x82, 0x14, 0x83, 0xAD, 0x3A, 0xF1, 0x66, 0x48, 0xDF,
    0x10, 0x87, 0xA9, 0x3E, 0xF5, 0x62, 0x4C, 0xDB, 0x4D, 0xDA, 0xF4, 0x63, 0xA8, 0x3F, 0x11, 0x86,
    0xAA, 0x3D, 0x13, 0x84, 0x4F, 0xD8, 0xF6, 0x61, 0xF7, 0x60, 0x4E, 0xD9, 0x12, 0x85, 0xAB, 0x3C};

// use this function to calculate CRC from 32-bit number

u8 crc8_4B(u32 bb)
{
    u8 crc;
    u32 t;
    t = (bb >> 24) & 0x000000FF;
    crc = ((bb >> 16) & 0x000000FF);
    t = crc ^ tableCRC[t];
    crc = ((bb >> 8) & 0x000000FF);
    t = crc ^ tableCRC[t];
    crc = (bb & 0x000000FF);
    t = crc ^ tableCRC[t];
    crc = tableCRC[t];
    return crc;
}

// use this function to calculate CRC from fixed length buffer

u8 CRC_Buffer(u8 NumOfBytes) // parameter = how many bytes from buffer to use to calculate CRC
{
    u32 t;
    u8 icrc;
    NumOfBytes -= 1;
    icrc = 1;
    t = Buffer[0];
    while (NumOfBytes--)
    {
        t = Buffer[icrc++] ^ tableCRC[t];
    }
    crc = tableCRC[t];
    return crc;
}

example:

u8 Buffer[BufferLength];

crc_value = u8 CRC_Buffer(BufferLength);
```

Recommended literature:

- Painless guide to CRC error detection algorithm; Ross N. Williams.
- Cyclic Redundancy Code (CRC) Polynomial Selection For Embedded Networks; P. Koopman, T. Chakravarty

Appendix 2 - 6-bit CRC calculation with 0x43 polynome for BiSS

BiSS communication offers a CRC value to check the correctness of the data read from the encoder. This chapter gives an example of the CRC calculation on the receiver side. The CRC calculation must always be done over the complete set of data. The polynomial for the CRC calculation is $P(x) = x^6 + x^1 + 1$, also represented as 0x43.

Following code example must be modified to fit actual data length. Position data, error and warning bits must all be included into calculation in the same order as in the BiSS data packet.

Code example:

```
u8 tableCRC6[64] = {
    0x00, 0x03, 0x06, 0x05, 0x0C, 0x0F, 0x0A, 0x09,
    0x18, 0x1B, 0x1E, 0x1D, 0x14, 0x17, 0x12, 0x11,
    0x30, 0x33, 0x36, 0x35, 0x3C, 0x3F, 0x3A, 0x39,
    0x28, 0x2B, 0x2E, 0x2D, 0x24, 0x27, 0x22, 0x21,
    0x23, 0x20, 0x25, 0x26, 0x2F, 0x2C, 0x29, 0x2A,
    0x3B, 0x38, 0x3D, 0x3E, 0x37, 0x34, 0x31, 0x32,
    0x13, 0x10, 0x15, 0x16, 0x1F, 0x1C, 0x19, 0x1A,
    0x0B, 0x08, 0x0D, 0x0E, 0x07, 0x04, 0x01, 0x02};

u8 crcBiSS(u32 bb)
{
    u8 crc;
    u32 t;
    t = (bb >> 30) & 0x00000003;
    crc = ((bb >> 24) & 0x0000003F);
    t = crc ^ tableCRC6[t];
    crc = ((bb >> 18) & 0x0000003F);
    t = crc ^ tableCRC6[t];
    crc = ((bb >> 12) & 0x0000003F);
    t = crc ^ tableCRC6[t];
    crc = ((bb >> 6) & 0x0000003F);
    t = crc ^ tableCRC6[t];
    crc = (bb & 0x0000003F);
    t = crc ^ tableCRC6[t];
    crc = tableCRC6[t];
    return crc;
}
```

Recommended literature:

- Painless guide to CRC error detection algorithm; Ross N. Williams.
- Cyclic Redundancy Code (CRC) Polynomial Selection For Embedded Networks; P. Koopman, T. Chakravarty

Head office

RLS merilna tehnika d.o.o.

Poslovna cona Žeje pri Komendi
Pod vrbami 2
SI-1218 Komenda
Slovenia

T +386 1 5272100

F +386 1 5272129

E mail@rls.si

www.rls.si

Document issues

Issue	Date	Page	Corrections made
7	5. 6. 2015	4	External magnetic field influence described
		6	Recommended fastener info added
		18	SPI output Minimum time after CS low data amended
8	26. 2. 2016	2	Magnetic ring chemical resistance description amended
		4	External magnetic field amended, flashing LED information added
		8 - 24	Latency changed from 250 μ s to 200 μ s Update rate changed from 4 kHz to 5 kHz
		8, 17, 25	BiSS output variant G removed, BiSS maximum request rate amended
		9	Asynchronous serial communication electrical connection picture and description amended
		10, 22	Command "v" amended, command 4 added, command 3 description amended
		13	SSI electrical connection picture and description amended
		14	SSI output type variant usage added
		16	BiSS-C electrical connection picture and timing diagram amended
		17	Bandwidth description added, communication parameters tables amended
		18, 21, 25	SPI variant T added
26, 27	Appendix 1 and 2 amended		
9	20. 6. 2016	6, 9, 17, 25	Multiturn counter function added and BiSS interface amended

RLS merilna tehnika d.o.o. has made considerable effort to ensure the content of this document is correct at the date of publication but makes no warranties or representations regarding the content. RLS merilna tehnika d.o.o. excludes liability, howsoever arising, for any inaccuracies in this document.
© 2016 RLS d.o.o.