

# I/O Terminal Installation Manual



Revision 1.2, April 2015

AKT-AN-200-000 2-Channel Thermocouple Module  
AKT-AN-400-000 4-Channel Thermocouple Module



Keep all manuals as a product component during the life span of the product.  
Pass all manuals to future users / owners of the product.

**KOLLMORGEN**<sup>®</sup>

*Because Motion Matters™*

## Record of Document Revisions

Revision	Remarks
1.0	Preliminary edition
1.1	Added dimensions to technical data table and mechanical drawing to Appendix A. For more information, see "Technical Data" page 9 and "Appendix A" page 31.
1.2	Corrected Kollmorgen part numbers.

## **IMPORTANT NOTICE**

Copyright© Kollmorgen™2010-2015. All rights reserved. Kollmorgen holds the copyright to this manual. All rights are reserved and no part of this publication may be reproduced or transmitted in any form or by any means without prior written consent from Kollmorgen.

### **Disclaimer**

The information in this manual was accurate and reliable at the time of its release. However, Kollmorgen. reserves the right to change the specifications of the product described in this manual without notice at any time.

This document contains proprietary and confidential information of Kollmorgen. The contents of the document may not be disclosed to third parties, translated, copied or duplicated in any form, in whole or in part, without the express written permission of Kollmorgen.

### **Registered Trademarks**

Kollmorgen is a registered trademark of Danaher Corp.

Technical changes which improve the performance of the device may be made without prior notice! Printed in the Federal Republic of Germany. All rights reserved. No part of this work may be reproduced in any form (by printing, photocopying, microfilm or any other method) or stored, processed, copied or distributed by electronic means without the written permission of Kollmorgen. All other proprietary names mentioned in this manual are the trademarks of their respective owners.

**April 2015**

<b>1</b>	<b>Safety Precautions</b>	
1.1	Safety Rules .....	6
1.2	State at Delivery .....	6
1.3	Personnel Qualification .....	6
1.4	Description of Notes and Warnings .....	6
<b>2</b>	<b>Overview</b>	
2.1	2-Channel Thermocouple Module (AKT-AN-200-000) .....	7
2.1.1	Technical Data .....	8
2.2	4-Channel Thermocouple Module (AKT-AN-400-000) .....	9
2.2.1	Technical Data .....	9
<b>3</b>	<b>Basic Function Principles</b>	
3.1	Functioning.....	11
3.2	Process Data Output Format .....	11
3.3	Voltage Limits.....	12
3.4	LED Display .....	12
3.5	Process Data.....	12
3.6	Connection .....	14
<b>4</b>	<b>Mounting and Wiring</b>	
4.1	Installation of Bus Terminals on Mounting Rails .....	15
4.1.1	Assembly.....	15
4.1.2	Disassembly.....	15
4.1.3	Connections Within a Bus Terminal Block .....	15
4.1.4	PE Power Contact.....	16
4.1.5	Wiring .....	16
4.2	Connections (AKT-AN-200-000) .....	17
4.3	Connections (AKT-AN-400-000) .....	18
<b>5</b>	<b>Automatic Configuration</b>	
5.1	Scan Device .....	19
5.2	Setting I/O Values .....	19
<b>6</b>	<b>Manual Configuration</b>	
6.1	Mapping .....	20
6.1.1	AKT-AN-200-000.....	21
6.1.2	AKT-AN-400-000.....	21
6.2	Control and Status Byte .....	22
6.2.1	Control Byte for Process Data Exchange .....	22
6.2.2	Status Byte for Process Data Exchange.....	22
6.3	Compensation .....	22
6.4	Register Descriptions .....	23
6.5	General Descriptions of Registers .....	23

- 6.5.1 Process Variables .....24
- 6.5.2 Type Register .....24
- 6.5.3 Manufacturer Parameters .....25
- 6.5.4 User Parameters .....25
- 6.5.5 Extended Application Region .....26
- 6.6 Terminal-Specific Register Description .....26
  - 6.6.1 Process Variables .....26
  - 6.6.2 Manufacturer Parameters .....26
  - 6.6.3 User Parameters .....27
- 6.7 Register Communication .....29
  - 6.7.1 Control Byte in Register Mode .....29
- 6.8 Register Table .....30
  
- Appendix A**
  - A.1 I/O 12mm Mechanical Drawing .....32

# 1 SAFETY PRECAUTIONS

This chapter provides safety information for the I/O terminal.

## 1.1 Safety Rules

The appropriate staff must ensure that the application or use of the products described satisfy all the requirements for safety, including all the relevant laws, regulations, guidelines and standards.

## 1.2 State at Delivery

All the components are supplied in particular hardware and software configurations appropriate for the application. Modifications to hardware or software configurations other than those described in the documentation are not permitted, and nullify any liability from Kollmorgen.

## 1.3 Personnel Qualification

This description is only intended for the use of trained specialists in control and automation engineering who are familiar with the applicable national standards.

## 1.4 Description of Notes and Warnings

The following notes and warnings are used in this manual. They are intended to alert the reader to the associated safety instructions.

**Danger** — This note is intended to highlight risks for the life or health of personnel.

**Warning** — This note is intended to highlight risks for equipment, materials or the environment.

**Note** — Indicates information that contributes to better understanding.

## 2 OVERVIEW

This section provides an overview of the I/O terminal.

**Note:** For information about configuring the I/O terminal, see the Kollmorgen Automation Suite™ IDE software and online help system.

### 2.1 2-Channel Thermocouple Module (AKT-AN-200-000)

The analog input terminals allow thermocouples to be connected directly. The Bus Terminal's circuitry can operate thermocouple sensors using the 2-wire technique. Linearization over the full temperature range is realized with the aid of a microprocessor. The temperature range can be selected freely. The error LEDs indicate a broken wire. Compensation for the cold junction is made through an internal temperature measurement at the terminals. Can also be used for mV measurement.

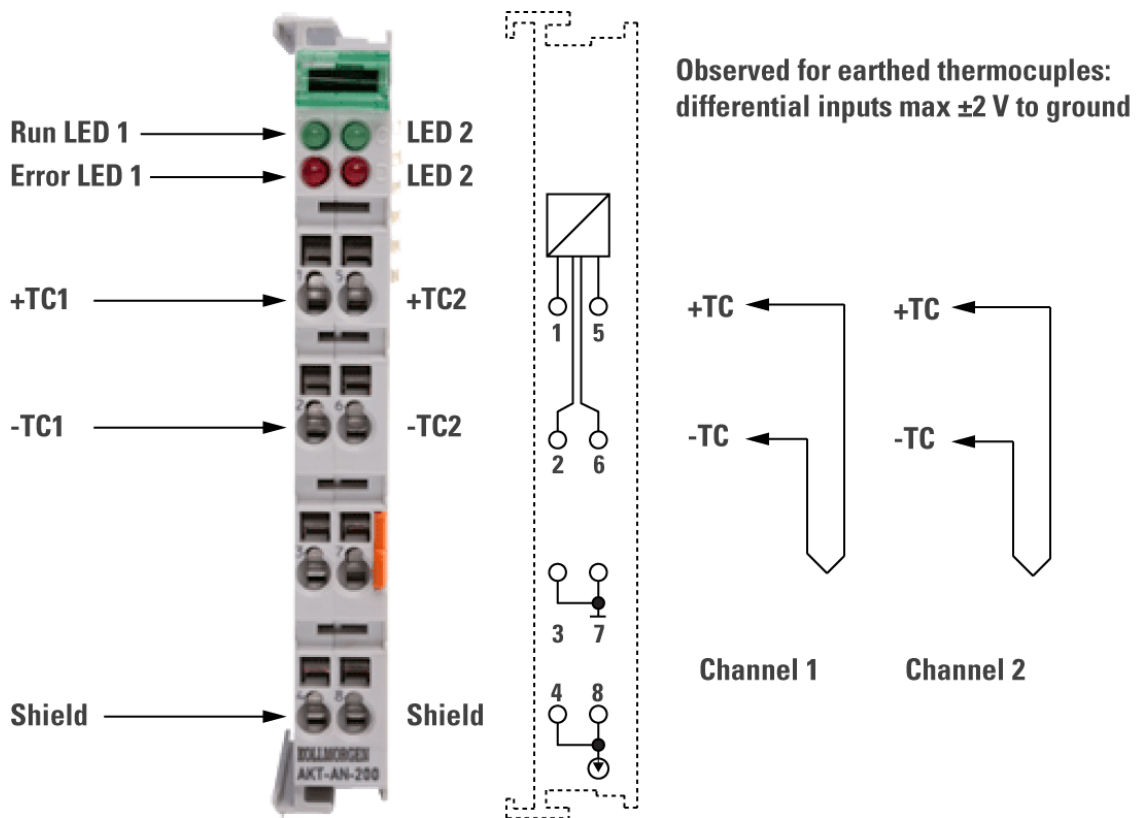

Figure 2.1 Contact Assembly Connection (Top View)

### 2.1.1 Technical Data

This section provides the technical details for the 2-channel thermocouple module.

Parameters	(AKT-AN-200-000)
Number of inputs	2
Power supply	Via the Standard-Bus
Thermocouple sensor type	Types J, K, L, B, E, N, R, S, T, U (default setting type K), mV measurement
Connection	2-wire
Temperature range	Within the respective defined range of the sensor (Default: type K; -100° ... 1370°C)
Resolution	0.1 °C per digit
Broken lead detection	Yes
Conversion time	~ 250 ms
Measuring error	< ±0.5 % (relative to full scale value)
Electrical isolation	500 Vrms (standard-bus / signal voltage)
Current consumption from Standard-Bus	Typ. 65 mA
Bits width in process image	Input: 2 x 16 bit data (2 x 8 bit control/status optional)
Configuration	No address setting, configuration via Bus Coupler or controller
Weight	70 g
Operating temperature	0°C ... +55°C
Storage temperature	-25°C ... +85°C
Relative humidity	95 % no condensation
Vibration / shock resistance	According to EN 60068-2-6 / EN 60068-2-27, EN 60068-2-29
EMC resistance burst / ESD	According to EN 61000-6-2 / EN 61000-6-4
Installation position	Any
Protection class	P20



## 2.2 4-Channel Thermocouple Module (AKT-AN-400-000)

The analog input terminal allows four thermocouples to be connected directly. The Bus Terminal's circuitry can operate thermocouple sensors using the 2-wire technique. Linearization over the full temperature range, which can be selected freely, is realized with the aid of a microprocessor. The error LEDs indicate a broken wire. Compensation for the cold junction is made through an internal temperature measurement at the terminals. Can also be used for mV measurement.

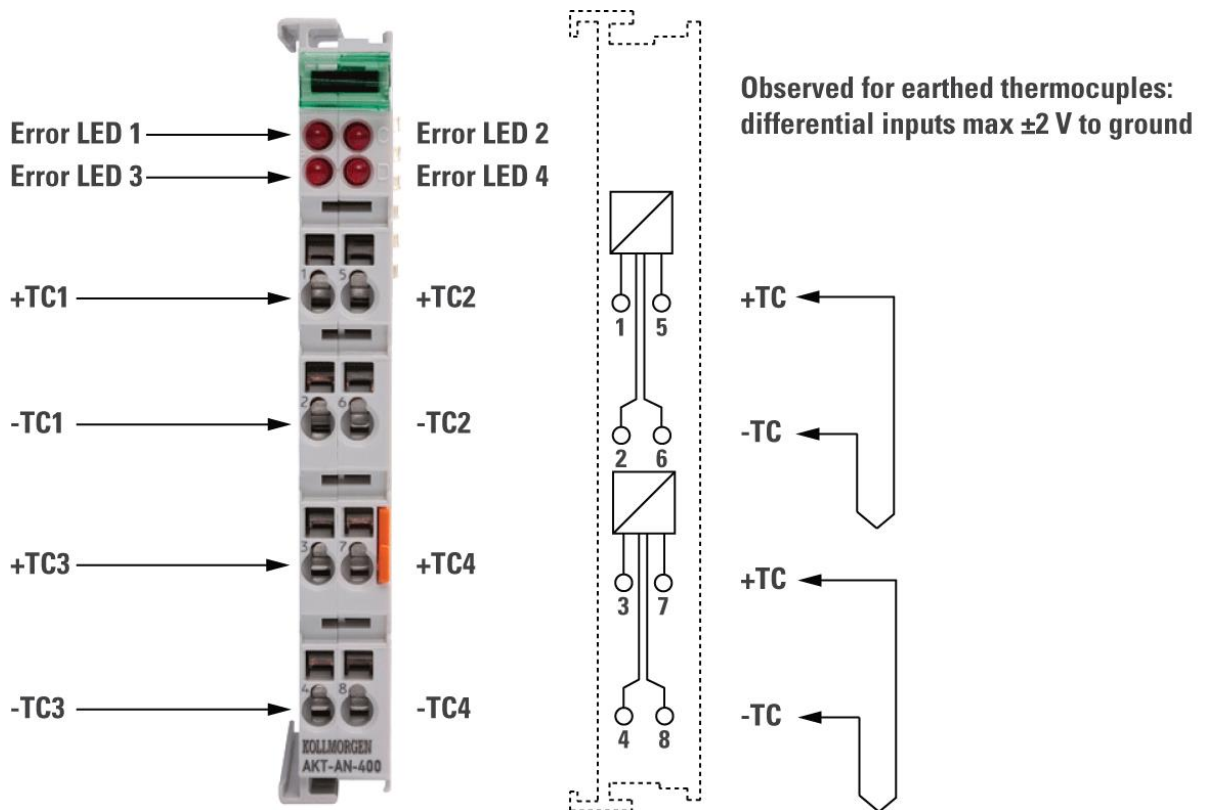

Figure 2.3 Contact Assembly Connection (Top View)

### 2.2.1 Technical Data

This section provides the technical details for the 4-channel analog input terminal.

Parameters	(AKT-AN-400-000)
Number of inputs	4
Power supply	Via the Standard-Bus
Thermocouple sensor type	Types J, K, L, B, E, N, R, S, T, U (default setting type K), mV measurement

<b>Parameters</b>	<b>(AKT-AN-400-000)</b>
Connection	2-wire
Temperature range	Within the respective defined range of the sensor (Default: type K; -100° ... 1370°C)
Resolution	0.1 °C per digit
Broken lead detection	Yes
Conversion time	~ 250 ms
Measuring error	< ±0.5 % (relative to full scale value)
Electrical isolation	500 Vrms (standard-bus / signal voltage)
Current consumption from Standard-Bus	Typ. 65 mA
Bits width in process image	Input: 2 x 16 bit data (2 x 8 bit control/status optional)
Configuration	No address setting, configuration via Bus Coupler or controller
Dimensions (W x H x D)	~15mm x 100mm x 70mm
Weight	~70 g
Operating temperature	0°C ... +55°C
Storage temperature	-25°C ... +85°C
Relative humidity	95 % no condensation
Vibration / shock resistance	According to EN 60068-2-6 / EN 60068-2-27, EN 60068-2-29
EMC resistance burst / ESD	According to EN 61000-6-2 / EN 61000-6-4
Installation position	Any
Protection class	P20

### 3 BASIC FUNCTION PRINCIPLES

The thermocouple terminals AKT-AN-200-000 (without broken wire detection) AKT-AN-400-000 can evaluate type J, K, B, E, N, R, S, T, U and L thermocouples. The characteristic curves are linearized and the reference temperature determined directly within the terminal. Temperatures are output in 1/10°C. The terminal is fully configurable via the Bus Coupler or the control. Different output formats may be selected or own scaling activated. In addition, linearization of the characteristic curve and determination and calculation of the reference temperature (temperature at the terminal connection contacts) can be switched off.

#### 3.1 Functioning

Thermocouples can be classified as active measuring sensors. They exploit the thermo-electric effect. Where two electrical conductors of different materials (e.g. iron and constantan) make contact, charge is transferred across the contact surface. A contact potential develops, and is strongly dependent on temperature. The thermally generated voltage is both a function of the temperature being measured,  $T$ , and of the reference temperature,  $T_v$ , at the point where contact is made with the thermocouple. Since the coefficients are determined at a reference temperature of 0°C, it is necessary to compensate for the effect of the reference temperature. This is done by converting the reference temperature into a reference voltage that depends on the type of thermocouple, and adding this to the measured thermal voltage. The temperature is found from the resulting voltage and the corresponding curve.

$$U_k = U_{meas} + U_{ref}$$

$$T_{aus} = f(U_k)$$

#### 3.2 Process Data Output Format

In the delivery state, the measured value is displayed in increments of 1/10 °C in two's complement format (integer). Other display types can be selected via the feature register (e.g. sign/amount representation, Siemens output format).

Measured Value	Hexadecimal Output	Signed Integer Output
-200.0°C	0xF830	-2000
-100.0°C	0xFC18	-1000
-0.1°C	0xFFFF	-1
0.0°C	0x0000	0
0.1°C	0x0001	1
100.0°C	0x03E8	1000
200.0°C	0x07D0	2000
500.0°C	0x1388	5000
850.0°C	0x2134	8500
1,000.0°C	0x2710	10000

### 3.3 Voltage Limits

$U_k > U_{kmax}$ : Bits 1 and 6 (over range and error bits) in the status byte are set. The linearization of the characteristic curve is continued with the coefficients of the upper range limit up to the limit stop of the A/D converter or to the maximum value of 0x7FFF.

$k < U_{kmin}$ : Bits 0 and 6 (under range and error bits) in the status byte are set. The linearization of the characteristic curve is continued with the coefficients of the lower range limit up to the limit stop of the A/D converter or to the minimum value of 0x8000.

For over range or under range the red error LED is switched on.

### 3.4 LED Display

The four LEDs indicate the operating state of the associated terminal channels.

Green LEDs: RUN (not applicable for AKT-AN-400-000)

- On: normal operation
- Off: Watchdog-timer overflow has occurred. If no process data are transmitted by the Bus Coupler for 100 ms, the green LEDs go out.

Red LEDs: ERROR

- On: Wire breakage. The resistance is in the invalid range of the characteristic curve of the respective thermocouple.
- Off: The resistance is in the valid range of the characteristic curve.

### 3.5 Process Data

The process data that are transferred to the terminal bus are calculated using the following equations:

Symbol	Parameter
X_ref	ADC value of the reference point
T_ref	Temperature of the reference point
U_ref	Voltage value of the reference point
X_R	ADC value of the temperature sensor
U <sub>m1</sub> :	Voltage value of the temperature sensor
A_a, B_a:	Manufacturer gain and offset compensation (R17, R18)
A_h, B_h	Manufacturer scaling
A_w, B_w	User scaling
U <sub>k</sub>	Sum of U <sub>ref</sub> and U <sub>m1</sub>
T	Measured temperature in 1/16 °C
T <sub>h</sub>	Temperature after manufacturer scaling (1/10 °C)
T <sub>a</sub>	Temperature after user scaling

Symbol	Parameter
T_AUS	Process data to PLC

A) Voltage value of the reference point:

$$T_{ref} = A_{00} * X_{-} \quad (1.0)$$

$$U_{ref} = a_1 * T_{ref2} + b_1 * T_{ref} + c_1 \quad (1.1)$$

B) Measured temperature in 1/16°C:

$$U_{m1} = A_a * X_m + B_a \quad (1.2)$$

$$U_k = U_{ref} + U_{m1} \quad (1.3)$$

$$T = a_0 * U_{k2} + b_0 * U_k + c_0 \quad (1.4)$$

C) Neither user nor manufacturer scaling are active:

$$T_{AUS} = T \quad (1.5)$$

D) Manufacturer scaling active (factory setting):

$$T_h = A_h * T + B_h \quad (1.6)$$

$$Y_{AUS} = T_h$$

E) User scaling active:

$$T_a = A_w * T + B_w \quad (1.7)$$

$$Y_{AUS} = T_a$$

F) Manufacturer and user scaling active: (1.8)

$$Y_1 = A_h * T + B_h$$

$$Y_2 = A_w * Y_1 + B_w$$

$$Y_{AUS} = Y_2$$

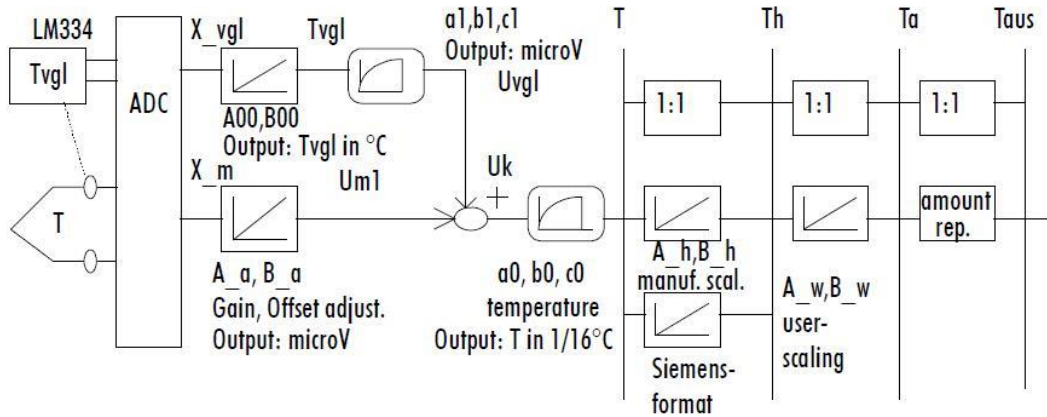

### 3.6 Connection

Due to the differential inputs of the terminals, different connection types are recommended depending on the type of thermocouple used. For earthed thermocouples, ground is connected to the screen. If the thermocouple has no earth connection, the ground, screen and -TC1 or -TC2 contacts are connected with each other.

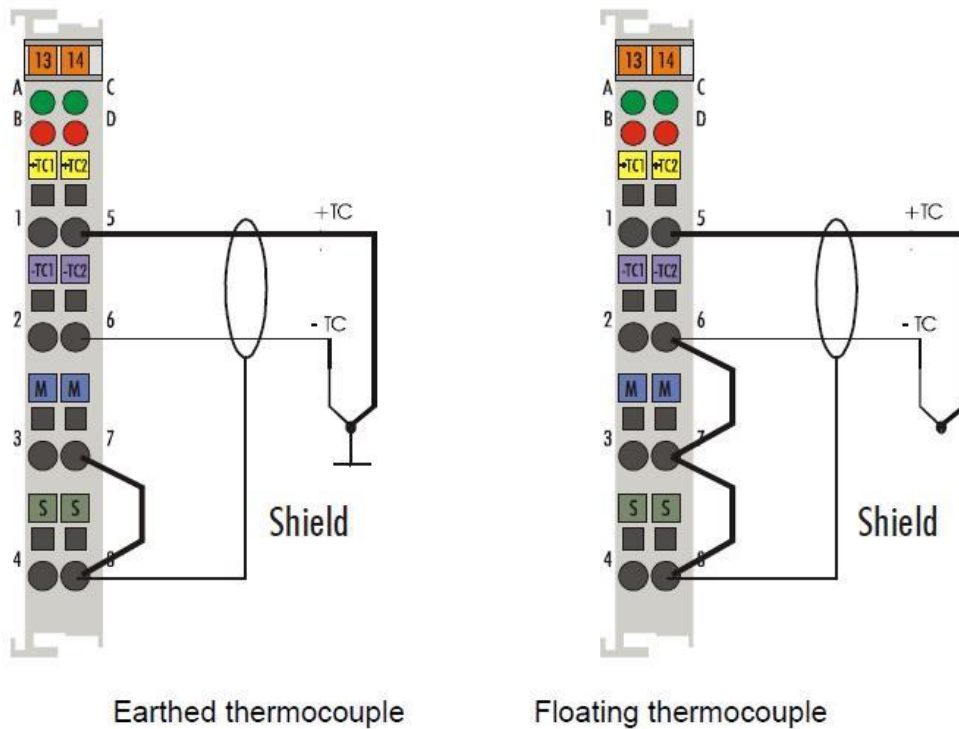

The examples show the situation for AKT-AN-200-000. For the AKT-AN-400-000, the screen should be connected to an additional screen terminal.

## 4 MOUNTING AND WIRING

This section provides mounting and wiring information for the operator terminal.

**Note:** For information about configuring the I/O terminal, see the Kollmorgen Automation Suite™ IDE software and online help system.

### 4.1 Installation of Bus Terminals on Mounting Rails

**DANGER!!** Bring the bus terminal system into a safe, powered down state before starting installation, disassembly or wiring of the Bus Terminals!

#### 4.1.1 Assembly

The Bus Coupler and Bus Terminals are attached to commercially available 35 mm mounting rails (DIN rails according to EN 50022) by applying slight pressure:

1. First attach the Fieldbus Coupler to the mounting rail.
2. The Bus Terminals are now attached on the right-hand side of the Fieldbus Coupler. Join the components with tongue and groove and push the terminals against the mounting rail, until the lock clicks onto the mounting rail.

If the Terminals are clipped onto the mounting rail first and then pushed together without tongue and groove, the connection will not be operational! When correctly assembled, no significant gap should be visible between the housings.

During the installation of the Bus Terminals, the locking mechanism of the terminals must not come into conflict with the fixing bolts of the mounting rail.

#### 4.1.2 Disassembly

Each terminal is secured by a lock on the mounting rail, which must be released for disassembly:

1. Carefully pull the orange-colored lug approximately 1 cm out of the disassembled terminal, until it protrudes loosely. The lock with the mounting rail is now released for this terminal, and the terminal can be pulled from the mounting rail without excessive force.
2. Grasp the released terminal with thumb and index finger simultaneous at the upper and lower grooved housing surfaces and pull the terminal away from the mounting rail.

#### 4.1.3 Connections Within a Bus Terminal Block

The electric connections between the Bus Coupler and the Bus Terminals are automatically realized by joining the components:

- The six spring contacts of the Standard Bus/Performance Bus deal with the transfer of the data and the supply of the Bus Terminal electronics.
- The power contacts deal with the supply for the field electronics and thus represent a supply rail within the bus terminal block. The power contacts are supplied via terminals on the Bus Coupler.

**Note:** During the design of a bus terminal block, the pin assignment of the individual Bus Terminals must be taken account of, since some types (e.g. analog Bus Terminals or digital 4-channel Bus Terminals) do not or not fully loop through the power contacts. Power Feed Terminals interrupt the power contacts and thus represent the start of a new supply rail.

#### 4.1.4 PE Power Contact

The power contact labeled PE can be used as a protective earth. For safety reasons this contact mates first when plugging together, and can ground short-circuit currents of up to 125 A.

**WARNING!!** Note that, for reasons of electromagnetic compatibility, the PE contacts are capacitatively coupled to the mounting rail. This may lead to incorrect results during insulation testing or to damage on the terminal (e.g. disruptive discharge to the PE line during insulation testing of a consumer with a nominal voltage of 230 V).

For insulation testing, disconnect the PE supply line at the Bus Coupler or the Power Feed Terminal! In order to decouple further feed points for testing, these Power Feed Terminals can be released and pulled at least 10 mm from the group of terminals.

**Note:** The PE power contact must not be used for other potentials!

#### 4.1.5 Wiring

Up to eight connections enable the connection of solid or finely stranded cables to the Bus Terminals. The terminals are implemented in spring force technology. Connect the cables as follows:

1. Open a spring-loaded terminal by slightly pushing with a screwdriver or a rod into the square opening above the terminal.
2. The wire can now be inserted into the round terminal opening without any force.
3. The terminal closes automatically when the pressure is released, holding the wire securely and permanently.

**Note:** Analog sensors and actors should always be connected with shielded, twisted paired wires.



## 4.2 Connections (AKT-AN-200-000)

The section describes the connections for the 2-channel thermocouple module.

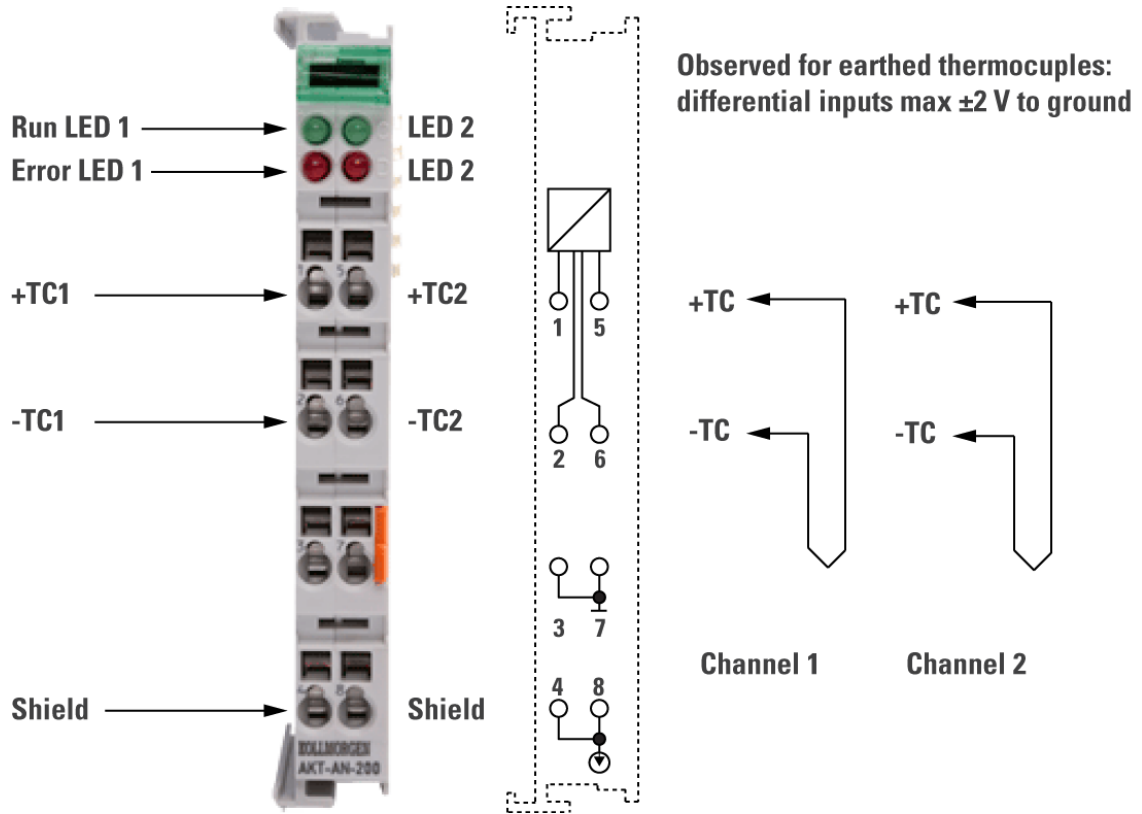

**Figure 4.1** Terminal Connections (2-Channel I/O)

### 4.3 Connections (AKT-AN-400-000)

The section describes the connections for the 4-channel thermocouple module.

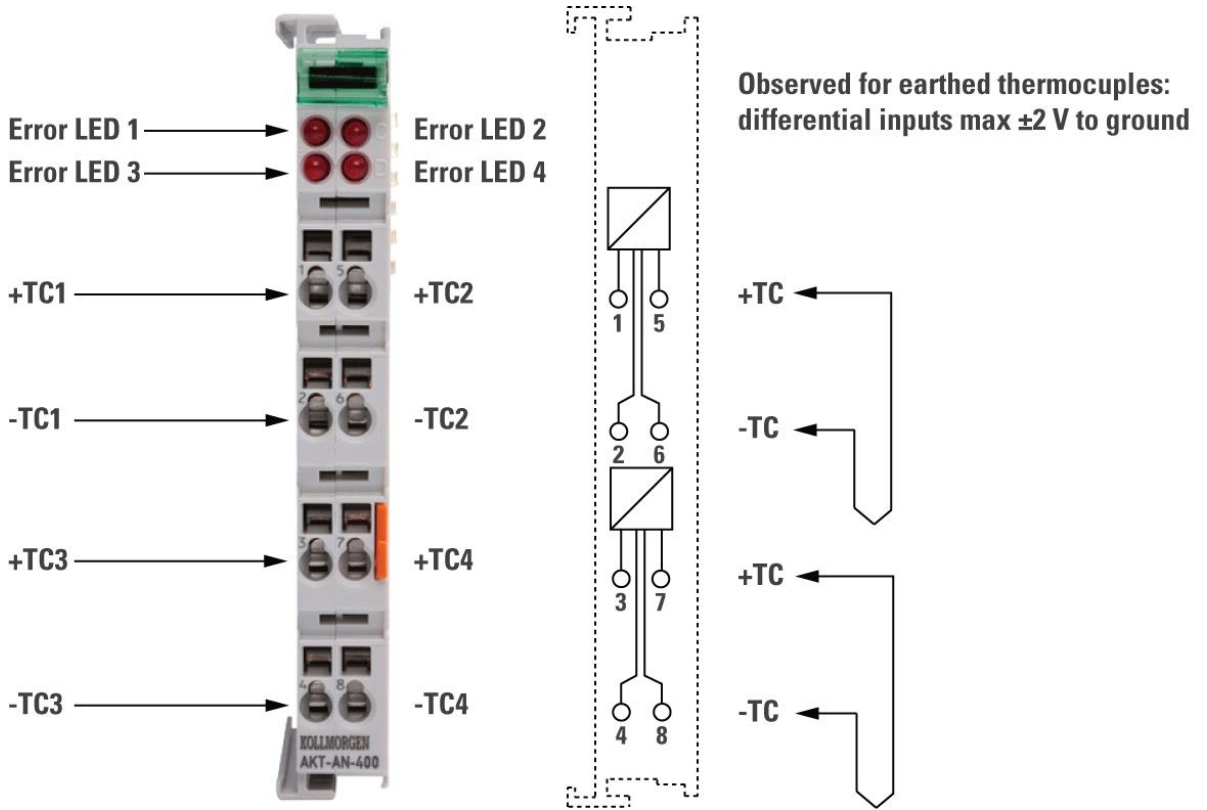

Figure 4.2 Terminal Connections (4-Channel I/O)

## 5 AUTOMATIC CONFIGURATION

This chapter will describe the basics of automatic configuration within the KAS Integrated Development Environment (IDE).

### 5.1 Scan Device

For ease-of-use the KAS IDE Scan Device feature provides automatic integration of I/O devices. This allows you to automatically locate and add I/O terminals to the application project:

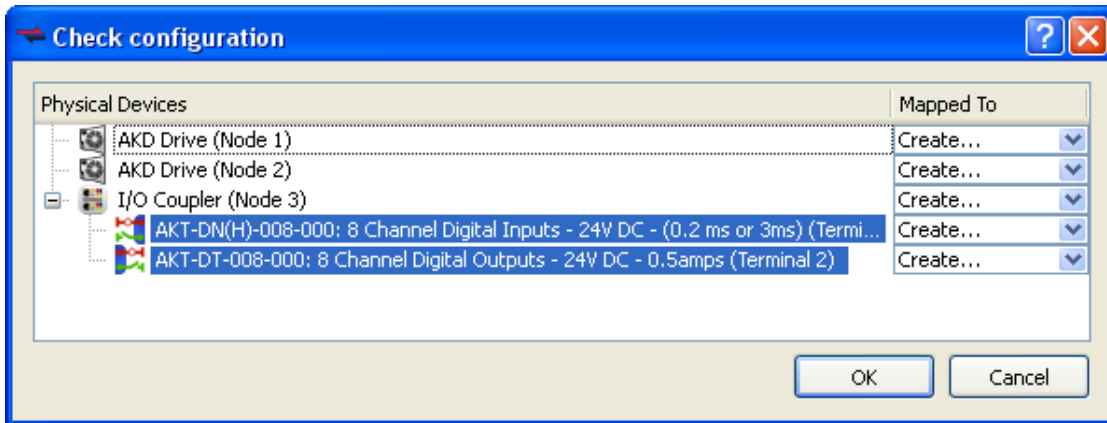

### 5.2 Setting I/O Values

After the I/O slice is mapped it can be selected in the application project and the offset and gain values can be set. Additionally, the IDE allows you to map the I/O points to variables in your application:

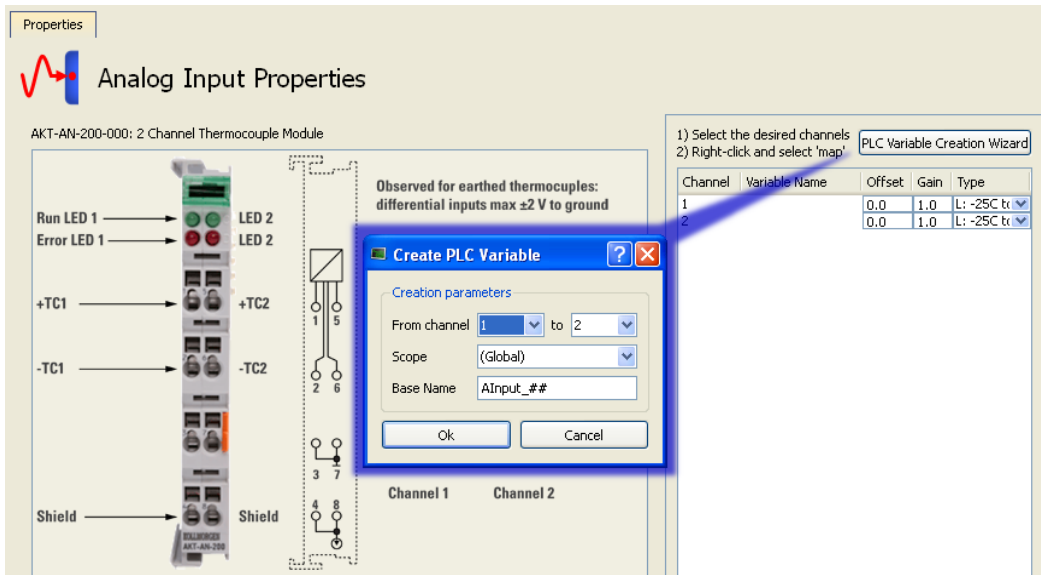

For more detailed information on these procedures refer to the section "EtherCAT Scan Device" in the KAS IDE online help.

## 6 MANUAL CONFIGURATION

Kollmorgen strongly recommends automatic configuration using the KAS IDE over manual configuration. For automatic configuration refer to chapter 5. Manual configuration is for advanced procedures only. The following sections provide information on:

1. Advanced configuration settings that can be made on Registers within this I/O module using EtherCAT Read and Write SDO function blocks in the application project code. These function blocks are located as follows:

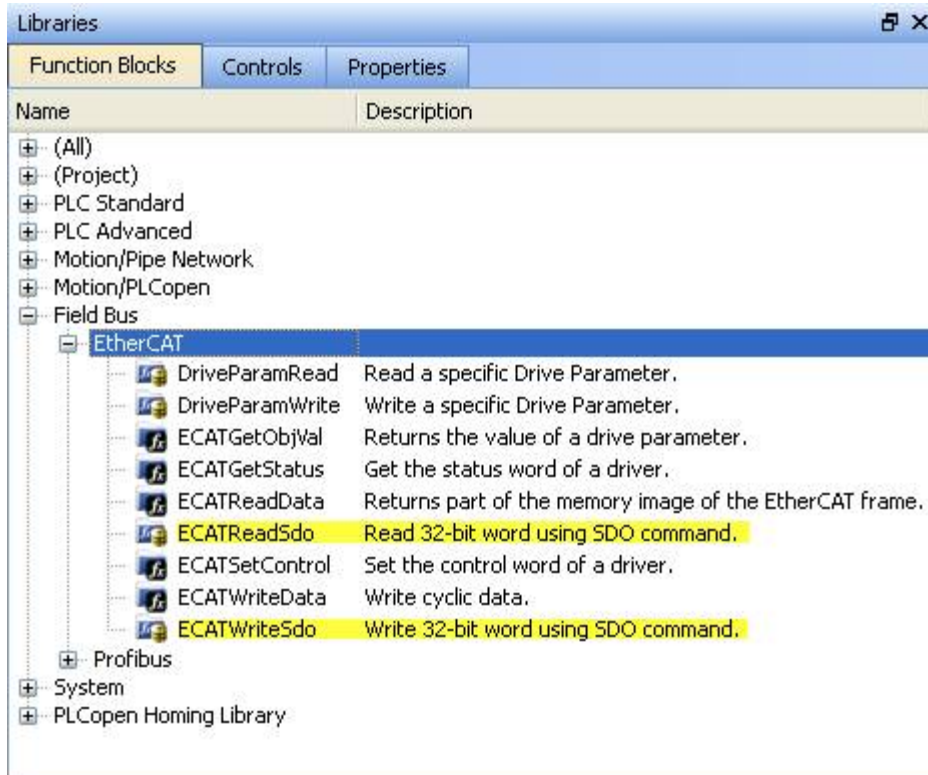

2. Manually mapping this I/O block into a KAS project. Manual mapping requires an additional configuration tool. Contact Kollmorgen for more information.

### 6.1 Mapping

As already described in the Terminal Configuration section, each Bus Terminal is mapped in the Bus Coupler. In the delivery state, this mapping occurs with the default settings of the Bus Coupler for this terminal.

If the terminals are fully evaluated, they occupy memory space in the input and output process image.

The following tables provide information about the terminal mapping, depending on the conditions set in the Bus Coupler.

**6.1.1 AKT-AN-200-000**

Default mapping for: EtherCAT.

Conditions	Word offset	High byte	Low byte
Complete evaluation: yes Motorola format: no Word alignment: yes	0	res.	Ch0 CB/SB
	1	Ch0 D0	Ch0 D1
	2	res.	Ch1 CB/SB
	3	Ch1 D0	Ch1 D1

Conditions	Word offset	High byte	Low byte
Complete evaluation: yes Motorola format: yes Word alignment: yes	0	res	Ch0 CB/SB
	1	Ch0 D0	Ch0 D1
	2	res.	Ch1 CB/SB
	3	Ch1 D0	Ch1 D1

**Legend:** Complete evaluation: The terminal is mapped with control and status byte.

Motorola format: Motorola or Intel format can be set.

Word alignment: The terminal is at word limit in the Bus Coupler.

Ch n SB: status byte for channel n (appears in the input process image).

Ch n CB: control byte for channel n (appears in the output process image).

Ch n D0: channel n, data byte 0 (byte with the lowest value)

Ch n D1: channel n, data byte 1 (byte with the highest value)

"-": This byte is not used or occupied by the terminal.

res.: reserved: This byte occupies process data memory, although it is not used.

**6.1.2 AKT-AN-400-000**

Default mapping for: EtherCAT.

Conditions	Word offset	High byte	Low byte
Complete evaluation: yes Motorola format: no Word alignment: yes	0	res.	Ch0 CB/SB
	1	Ch0 D1	Ch0 D0
	2	res.	Ch1 CB/SB
Complete evaluation: yes Motorola format: no	3	Ch1 D1	Ch1 D0
	4	res.	Ch2 CB/SB

Conditions	Word offset	High byte	Low byte
Word alignment: yes	5	Ch2 D1	Ch2 D0
	6	res.	Ch3 CB/SB
	7	Ch3 D1	Ch3 D0

Conditions	Word offset	High byte	Low byte
Complete evaluation: yes Motorola format: yes Word alignment: yes	0	res.	Ch0 CB/SB
	1	Ch0 D0	Ch0 D1
	2	res.	Ch1 CB/SB
	3	Ch1 D0	Ch1 D1
	4	res.	Ch2 CB/SB
	5	Ch2 D0	Ch2 D1
	6	res.	Ch3 CB/SB
	7	Ch3 D0	Ch3 D1

**Legend** See AKT-AN-200-000 mapping.

## 6.2 Control and Status Byte

This section provides information on control and status byte

### 6.2.1 Control Byte for Process Data Exchange

The control byte is transmitted from the controller to the terminal.

### 6.2.2 Status Byte for Process Data Exchange

The status byte is transmitted from the terminal to the controller. The status byte contains various status bits for the analog input channel:

status byte:

Bit 7 =  $0_{bin}$

Bit 6 =  $1_{bin}$ : ERROR - general error bit

Bit 5 to bit 2: reserved

Bit 1 =  $1_{bin}$ : Over range

Bit 0 =  $1_{bin}$ : Under range

## 6.3 Compensation

The terminals are compensated when delivered.

In order to compensate tolerances of the external components, gain and offset registers for compensating the thermocouple voltage are implemented for each channel, i.e. R17 (thermocouple voltage offset) and R18 (thermocouple voltage gain). For compensating the reference point temperature (temperature at the transition between the thermocouple and the terminal contacts), a gain register (R21) is implemented, which is identical for both sets of registers.

Compensation can be carried out as follows:

First, the offset is carried out with 0V input voltage, reference temperature deactivated and linearization switched off. 0xF100 is entered in the feature register. This is followed by gain compensation with a maximum voltage of 125 mV (typical value: 70 mV). For this terminal setting with deactivated manufacturer scaling, the voltage is displayed with 4  $\mu$ V per digit. Gain and offset compensation of the thermocouple voltage is carried out separately for each channel.

In the next step, the temperature of the reference point is compensated. To this end, a thermocouple has to be selected via the feature register, and reference point temperature compensation must be active (R32 0x1006 type K). With short-circuited inputs (0 V), the temperature of the terminal contacts is determined, and the temperature output by the terminal (measured via an internal temperature sensor) is set accordingly (via R21).

The reference point temperature only has to be calibrated once for each terminal, i.e. R21 is identical for both channels.

## 6.4 Register Descriptions

Different operating modes or functionalities may be set for the complex terminals. The General Description of Registers explains those register contents that are the same for all complex terminals.

The terminal-specific registers are explained in the following section.

Access to the internal terminal registers are described in the Register Communication section.

## 6.5 General Descriptions of Registers

Complex terminals that possess a processor are able to exchange data bi-directionally with the higher-level controller. These terminals are referred to below as intelligent Bus Terminals. These include analog inputs, analog outputs, serial interface terminals (RS485, RS232, TTY etc.), counter terminals, encoder interface, SSI interface, PWM terminal and all other configurable terminals.

The main features of the internal data structure are the same for all the intelligent terminals. This data area is organized as words and comprises 64 registers. The important data and parameters of the terminal can be read and set through this structure. It is also possible for functions to be called by means of corresponding parameters. Each logical channel in an intelligent terminal has such a structure (4-channel analog terminals therefore have 4 sets of registers).

This structure is divided into the following areas: (A detailed list of all registers can be found in the Appendix.)

Register	Application
0 to 7	Process variables
8 to 15	Type register
16 to 30	Manufacturer parameters
31 to 47	User parameters
48 to 63	Extended user area

### 6.5.1 Process Variables

**R0 to R7: Registers in the internal RAM of the terminal** – The process variables can be used in addition to the actual process image. Their function is specific to the terminal.

**R0 to R5: Terminal-specific registers** – The function of these registers depends on the respective terminal type (see terminal-specific register description).

**R6: Diagnostic register** – The diagnostic register can contain additional diagnostic information. Parity errors, for instance, that occur in serial interface terminals during data transmission are indicated here.

#### **R7: Command register**

High-Byte\_Write = function parameter

Low-Byte\_Write = function number

High-Byte\_Read = function result

Low-Byte\_Read = function number

### 6.5.2 Type Register

**R8 to R15: Registers in the internal ROM of the terminal** – The type and system parameters are hard programmed by the manufacturer, and the user can read them but cannot change them.

**R8: Terminal type** – The terminal type in register R8 is needed to identify the terminal.

**R9: Software version (X.y)** – The software version can be read as a string of ASCII characters.

**R10: Data length** – R10 contains the number of multiplexed shift registers and their length in bits. The Bus Coupler sees this structure.

**R11: Signal channels** – Related to R10, this contains the number of channels that are logically present. Thus for example a shift register that is physically present can perfectly well consist of several signal channels.

**R12: Minimum data length** – The particular byte contains the minimum data length for a channel that is to be transferred. If the MSB is set, the control and status byte is not necessarily required for the terminal function and is not transferred to the control, if the Bus Coupler is configured accordingly.

#### **R13: Data type register**



<b>Data Type Register</b>	<b>Description</b>
0x00	Terminal with no valid data type
0x01	Byte array
0x02	Structure 1 byte n bytes
0x03	Word array
0x04	Structure 1 byte n words
0x05	Double word array
0x06	Structure 1 byte n double words
0x07	Structure 1 byte 1 double word
0x08	Structure 1 byte 1 double word
0x11	Byte array with variable logical channel length
0x12	Structure 1 byte n bytes with variable logical channel length (e.g. 60xx)
0x13	Word array with variable logical channel length
0x14	Structure 1 byte n words with variable logical channel length
0x15	Double word array with variable logical channel length
0x16	Structure 1 byte n double words with variable logical channel length

**R14: Reserved**

**R15: Alignment bits (RAM)** – The alignment bits are used to place the analog terminal in the Bus Coupler on a byte boundary.

**6.5.3 Manufacturer Parameters**

**R16 to R30: Manufacturer parameter area (SEEROM)** – The manufacturer parameters are specific for each type of terminal. They are programmed by the manufacturer, but can also be modified by the controller. The manufacturer parameters are stored in a serial EEPROM in the terminal, and are retained in the event of voltage drop-out. These registers can only be altered after a code-word has been set in R31.

**6.5.4 User Parameters**

**R31 to R47: User parameter area (SEEROM)** – The application parameters are specific for each type of terminal. They can be modified by the programmer. The application parameters are stored in a serial EEPROM in the terminal, and are retained in the event of voltage drop-out. The user area is write-protected by a code-word.

**R31: Code-word register in RAM** – The code-word **0x1235** must be entered here so that parameters in the user area can be modified. If any other value is entered into this register, the write-protection is active. When write protection is not active, the code word is returned when the register is read. If the write protection is active, the register contains a zero value.

**R32: Feature register** – This register specifies the terminal's operating modes. Thus, for instance, a user-specific scaling can be activated for the analog I/Os.

**R33 to R47 Terminal-specific Registers** – The function of these registers depends on the respective terminal type (see terminal-specific register description).

### 6.5.5 Extended Application Region

**R47 to R63** – Extended registers with additional functions.

## 6.6 Terminal-Specific Register Description

This section provides specific register information for this I/O.

### 6.6.1 Process Variables

**R0: Raw ADC value (X\_R)** – This register contains the unfiltered ADC value of the connected element according to (Eq. 0.1) (0x0000 corresponds to approx. -125mV, 0x8000 to approx. 0V, 0xFFFF to approx. 125 mV, i.e. gain and offset errors are present)

**R1 to R5: Reserved**

**R6: Diagnostic register**

High byte: reserved

Low byte: status byte

### 6.6.2 Manufacturer Parameters

**R17: Hardware compensation - offset (B\_a)**

16 bit signed integer

This register is used for offset compensation of the terminal (Eq. 1.2).

Register value approx. 0x0000

**R18: Hardware compensation - gain (A\_a)**

This register is used for gain compensation of the terminal (Eq. 1.2).

Register value approx. 0x3D4X

**R19: Manufacturer scaling - offset (B\_h)**

16 bit signed integer [0x0000]

This register contains the offset of the manufacturer's equation of the straight line (1.6). The straight-line equation is activated via register R32.

**R20: Manufacturer scaling - gain (A\_h)**

16 bits signed integer \*2-8 [0x00A0]

This register contains the scale factor of the manufacturer's equation of the straight line (1.6). The straight-line equation is activated via register R32.

**R21: Manufacturer gain compensation for reference voltage**

[approx. 0x01XX]

**6.6.3 User Parameters****R32: Feature Register**

[0x1006]

The feature register specifies the terminal's operating mode.

Feature bit no.		Description of the operating mode
Bit 0	1	User scaling (R33, R44) active [0]
Bit 1	1	Manufacturer scaling (R19, R20) active [1]
Bit 2	1	Watchdog timer active [1] In the delivery state, the watchdog timer is switched on.
Bit 3	1	Sign / amount representation [0] Sign / amount representation is active instead of two's-complement representation. (-1 = 0x8001)
Bit 4	1	Siemens output format [0] This bit is used for inserting status information on the lowest 3 bits (see below).
Bit 5	1	Activates filter constant in R37 [0]
Bit 6	1	Deactivates the measuring current for broken wire detection
Bit 7	–	reserved, do not change!
Bit 8	1	Reference temperature off [0]
Bit 9	–	reserved, do not change!
Bit 10	1	Checking of the lower measuring range limit not applicable. [0]
Bit 15,14,13,12	<b>Element</b>	<b>Valid measuring range</b>
0 0 0 0	Type: L	-25°C to 900°C
0 0 0 1	Type: K	-100°C to 1,370°C
0 0 1 0	Type: J	-100°C to 1,200°C

Feature bit no.			Description of the operating mode
0 0 1 1	Type: E		-100°C to 1,000°C
0 1 0 0	Type: T		-100°C to 400°C
0 1 0 1	Type: N		-100°C to 1,300°C
0 1 1 0	Type: U		-25°C to 600°C
0 1 1 1	Type: B		600°C to 1,800°C
1 0 0 0	Type: R		0°C to 1,700°C
1 0 0 1	Type: S		0°C to 1,700°C
	Output in $\mu\text{V}$ resolution		Valid measuring range
1 1 0 1	1 $\mu\text{V}^*$	1.6 $\mu\text{V}^{**}$	$\pm 30$ mV
1 1 1 0	2 $\mu\text{V}^*$	3.2 $\mu\text{V}^{**}$	$\pm 60$ mV
1 1 1 1	4 $\mu\text{V}^*$	6.4 $\mu\text{V}^{**}$	$\pm 120$ mV ( $\pm 80$ mV for AKT-AN-400-000)

\*) no scaling active

\*\*) only manufacturer scaling active

#### Examples:

Bit 15 to 12: 1111, no scaling active:

The output format is as follows: 1 digit corresponds to 1/16 °C or to 4  $\mu\text{V}$

Bit 15 to 12: 1111, manufacturer scaling activated via bit 1 of the feature register:

The output format is as follows: 1 digit corresponds to 1/10 °C or to 6.4  $\mu\text{V}$

Measured Value	Bit 15 ... 3	Bit 2 X	Bit 1 Error	Bit 0 Overflow
Out of range		0	0	1
In range	Process data	0	0	0

#### R33: User scaling - offset (B\_w)

16 bit signed integer

This register contains the offset of the user straight-line equation (1.7). The straight-line equation is activated via register R32.

#### R34: User scaling - gain (A\_w)

16 bits signed integer\* 2-8

This register contains the scale factor of the user straight-line equation (1.7)

The straight-line equation is activated via register R32.

#### R35 and R36: reserved

**R37: Filter constant**

[0x0000]

**Note:** This documentation applies to all terminals from software version 3x. The version number can be found within the serial number on the right-hand side face of the terminal: xxxx3xxx

Example: 5298**3A2A** ⇒ The firmware version is **3A**.

**6.7 Register Communication****Register Access Via Process Data Exchange | Bit 7=1bin: Register Mode**

If bit 7 of the control byte is set, then the first two bytes of the user data are not used for exchanging process data, but are written into or read from the terminal's register set.

**Bit 6=0bin: read | Bit 6=1bin: write**

Bit 6 of the control byte specifies whether a register should be read or written. If bit 6 is not set, then a register is read out without modifying it. The value can then be taken from the input process image.

If bit 6 is set, then the user data is written into a register. As soon as the status byte has supplied an acknowledgement in the input process image, the procedure is completed (see example).

**Bit 0 to 5: Address**

The address of the register that is to be addressed is entered into bits 0 to 5 of the control byte.

**6.7.1 Control Byte in Register Mode**

MSB							
Reg = 1	W/R	A5	A4	A3	A2	A1	A0

REG = 0bin: Process data exchange

REG = 1bin: Access to register structure

W/R = 0bin: Read register

W/R = 1bin: Write register

A5...A0 = register address

Address bits A5 to A0 can be used to address a total of 64 registers.

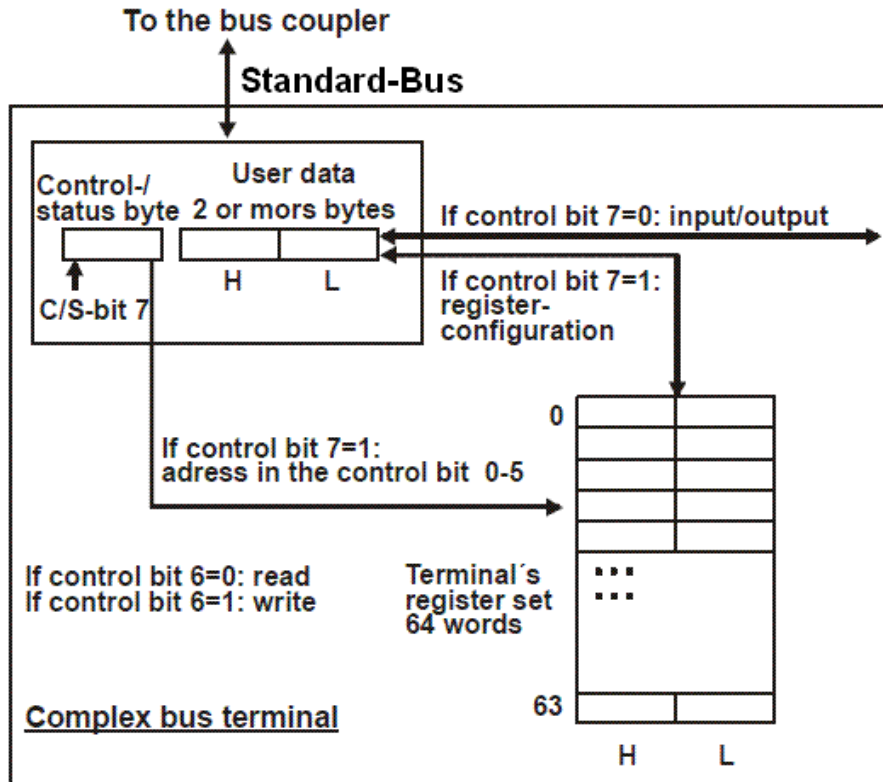

The control or status byte occupies the lowest address of a logical channel. The corresponding register values are located in the following 2 data bytes.

## 6.8 Register Table

These registers exist once for each channel.

Address	Denomination	Default value	R/W	Storage medium
R0	Raw ADC value	variable	R	RAM
R1	reserved	0x0000	R	
...	...	...	...	
R5	reserved	0x0000	R	
R6	Diagnostic register	variable	R	RAM
R7	Command register not used	0x0000	R	
R8	Terminal type	AKT-AN-200-000	R	ROM
R9	Software version number	0x????	R	ROM
R10	Multiplex shift register	0x0218/0130	R	ROM
R11	Signal channels	0x0218	R	ROM

Address	Denomination	Default value	R/W	Storage medium
R12	Minimum data length	0x0098	R	ROM
R13	Data structure	0x0000	R	ROM
R14	reserved	0x0000	R	
R15	Alignment register	variable	R/W	RAM
R16	Hardware version number	0x????	R/W	SEEROM
R17	Hardware compensation: Offset	specific	R/W	SEEROM
R18	Hardware compensation: Gain	specific	R/W	SEEROM
R19	Manufacturer scaling: Offset	0x0000	R/W	SEEROM
R20	Manufacturer scaling: Gain	0x00A0	R/W	SEEROM
R21	Hardware compensation: Reference temperature	specific	R/W	SEEROM
R22	reserved	0x0000	R/W	SEEROM
...	...	...	...	...
R30	reserved	0x0000	R/W	SEEROM
R31	Code word register	variable	R/W	RAM
R32	Feature register	0x1006	R/W	SEEROM
R33	User scaling: Offset	0x0000	R/W	SEEROM
R34	User scaling: Gain	0x0100	R/W	SEEROM
R35	reserved	0x0000	R/W	SEEROM
R36	reserved	0x0000	R/W	SEEROM
R37	reserved	0x0138	R/W	SEEROM
...		...	...	...
R63	reserved	0x0000	R/W	SEEROM

# APPENDIX A

This section provides the mechanical drawing of the I/O Terminal.

## A.1 I/O 12mm Mechanical Drawing

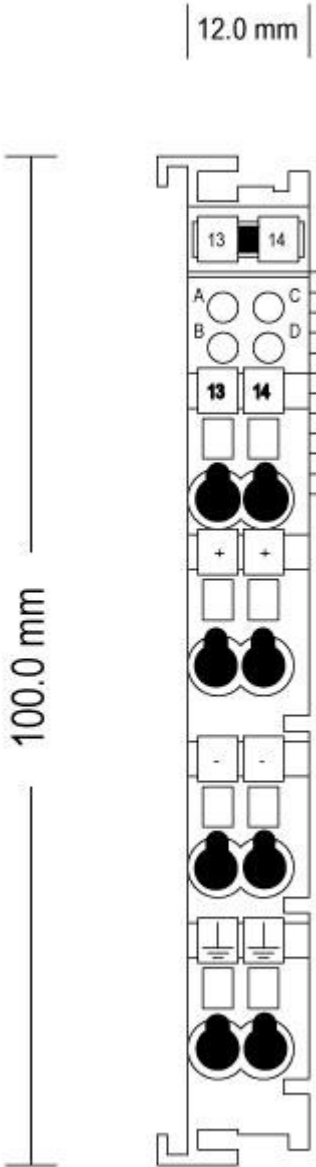



### **About Kollmorgen**

Kollmorgen is a leading provider of motion systems and components for machine builders. Through world-class knowledge in motion, industry-leading quality and deep expertise in linking and integrating standard and custom products, Kollmorgen delivers breakthrough solutions that are unmatched in performance, reliability and ease-of-use, giving machine builders an irrefutable marketplace advantage.

For assistance with your application needs, contact us at: 540-633-3545, [contactus@kollmorgen.com](mailto:contactus@kollmorgen.com) or visit [www.kollmorgen.com](http://www.kollmorgen.com)

#### **North America**

##### **Kollmorgen**

203A West Rock Road  
Radford, VA 24141 USA  
Phone: 1-540-633-3545  
Fax: 1-540-639-4162

#### **Europe**

##### **Kollmorgen**

Wacholderstraße 40 – 42  
40489 Düsseldorf Germany  
Phone: + 49 (0) 203-9979-235  
Fax: + 49 (0) 203-9979-3314

**KOLLMORGEN**<sup>®</sup>

*Because Motion Matters™*