

# Grounding and Shielding Existing Equipment

How to effectively minimize EMI issues when best practices are not available

**KOLLMORGEN**<sup>®</sup>

*Because Motion Matters™*

Grounding and Shielding is an often misunderstood process. It is common to hear quotes ranging from “it’s magic!” to “the rules change all the time!” and “there’s no way to understand it!” These emotional statements are repeated but not true. There is a process, it hasn’t changed, and the more one knows about coupling mechanisms the more one will see that it’s sound engineering principals. There’s no illusion - sound mathematical and logical process can resolve or reduce electromagnetic interference (EMI) problems to achieve desired machine performance. Let’s review a few of these comments one at a time to dispel these misconceptions.

### It’s Magic!

Undesired signals couple into signals via four coupling factors; magnetic (inductive) coupling, capacitive (high speed voltage changes ( $dV/dt$ )) coupling, direct coupling, and radiative (Rf) coupling. These factors have their basis in science. One may not be able to predict the exact path just as one cannot predict the exact path of lightning, but one knows how to limit the chances of getting struck. Lightning is nothing more than one of the most powerful of the EMI events.

### The Rules Change All the Time

To understand this statement, one has to look at history and the frequency response. Tube receivers from the 1960’s have a combination of grounds at both ends, as well as audio sections that are grounded at one end. It all has to do with frequency response and sensitivity. In the case of the tuner sections (RF frequency reception is from 87.5 MHz to 108.1 MHz in the US) the main culprit is unwanted high frequency. The grounds are at both ends with no break in the shields. Both magnetic and capacitive coupling shields are used (more on that later) but the audio has grounds at one end, the signal source. Therein lays the confusion.

The audio is susceptible to 60 Hz noise. This is low a frequency. It is also sensitive to ground differentials since it is single ended and a high gain. There’s the key, ground differentials and low frequency. In today’s circuitry differential inputs are used to resolve the 60 Hz noise caused from ground differentials. Thus, the rules have not changed; but the technology has. In those sporadic cases where one has a single ended circuit with high gain, one may have to use the single ground reference and isolate it from other grounds. Secondary shields may also be used with the internal shield referenced at the source and the secondary shield at both ends rejecting the high frequency.

### There’s No Way to Understand It!

Numerous books, articles and white papers are written all the time about this. They include information on the coupling mechanisms and the sound mathematics of measuring inductance, capacitance, mutual inductance, resistance, and

field intensity. These are all measurable quantities, and manufacturer’s such as Kollmorgen provide recommendations on how to connect amplifiers to minimize EMI issues.

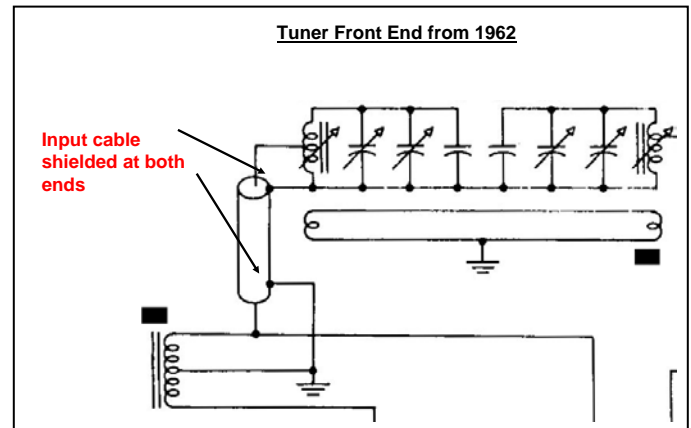

### The Source & the Victim - Sometimes They Are One in the Same!

With feedback loops, it can be very difficult to determine the source of the noise. In the case of power supplies or servo amplifiers, it can be a daunting task. The current and voltage feedback of both of these devices are relatively high gain and will feed upon themselves if care is not taken to preserve the integrity of the intended signal and the robust rejection of the unintended signals.

Many switch mode power supplies have both current and voltage feedback. Often, they are operating at higher frequencies (400 KHz is quite common) and can create a problem. If care is not taken with the layout and shielding of the voltage sense, interference can come from the PWM leaking into the voltage sense. In this case, the power supply is both the victim and source of the problem. The solution is to isolate the signals with layout and shielding changes. The voltage source should be shielded with a 360 degree coverage braid; the PWM edges can be substantially tamed with either common mode or differential mode inductors depending on the cause.

## What is the Shield and What is its Purpose?

Most of the time the shield can be viewed as a band aid on a wound. Although necessary, one should not ignore the bleeding below. It is important to understand what is causing the noise and whether it can be resolved. The shield can be considered an isolation barrier. One barrier on the source of the noise and one barrier on the receiver will deliver the greatest integrity.

## Stop the Bleeding Where Possible

There are many techniques relating to noise that are truly resolution and not just reduction. In the case of high  $dV/dt$  signals like the PWM of an amplifier, slowing of the rise time may break the coupling factor of capacitance once the rise time falls below the reactance.

## RF Signals

Generating RF signals is easy if one is not careful. Any time that a spark gap is generated (relays are frequent culprits here), an RF signal may be generated too. The resulting voltage signal is not likely to be a problem on the user's end because it is not a  $\frac{1}{2}$  wavelength away; but the subsequent magnetic field that it generates may cause a tremendous problem. The other problem is that this signal is being broadcast and may interfere with other equipment.

In the 1970's when automobiles would disrupt radios as they drove nearby, it was due to the spark plugs drawing an arc from the collapse of the magnetic field of the coil. The magnetic fields will collapse with a factor of  $E = L di/dt$ . A side effect is that any energy not recovered results in heat or transmission that creates a radiative signal. The radio signal has both magnetic and voltage components that will transmit on a ratio of  $di/dt$  and  $dV/dt$ . It follows Ohm's Law.  $E = IR$  ( $Z$  when speaking of impedance) and substituting the change in voltage and current yields  $Z = dV/dt / di/dt$ . Once the signal current and voltage rate is at 377 ohms the signal is transmitted. The significance of the 377 ohms is the impedance of dry air. So how did the automobile industry solve this problem? They added a resistor in series with the spark plug. The spark still occurs but does not match the impedance of air, and as a result it will not transfer power.

Understanding the mechanism of transmission and reception of a radiative signal is vital to effectively eliminating the problems associated with them. To transmit or receive a radiative signal requires an antenna. An antenna does not necessarily mean an intended antenna, but anything that can become an antenna. There are two fields on an antenna, the E-field which is voltage and the H-field which is magnetic. When they are in phase on the antenna, they will support each other and maintain their resonant relationship, sometimes referred to as sympathetic.

The drawing in the next column shows the two fields related to transmission and reception of a signal. The left image is when the device is less than one wavelength ( $\lambda$ ) away from the source (called the near field area or inductive area), and the

right image is when the device is greater than one wavelength away from the transmission (called the far field or radiative field area). When the signal is monitored in the near field area, the phase relationship of the two radiation fields are out of phase and true characterization of the signal within this is not reliable. However, the magnetic field is affecting things and a magnetic shield is necessary to prevent this from escaping the transmission source and to prevent the reception. Outside of this, when in the far field area the signal can still be received with a voltage antenna and the characteristics of the signal can be seen. This is why an EMC lab that is measuring signals from 30 MHz is greater than 10 m distance from the unit under test (UUT), since this is the wavelength of 30 MHz and they are using an E-field (voltage).

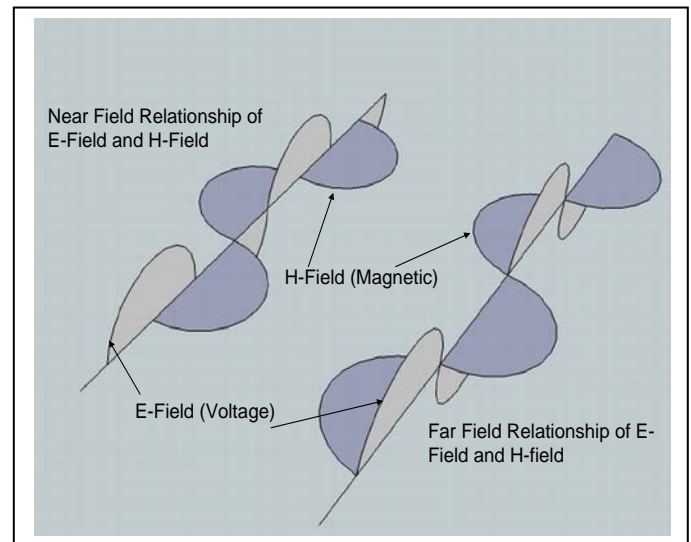

*Near Field and Far Field affects of radiative noise*

## Magnetic Coupling

PWM signals from servo amplifiers and power supplies are often culprits for inducing their signals into unwanted areas. The real issue with them is that they have power and can turn devices on by their field. Leds in a magnetic field, for example, may begin to illuminate in a high magnetic field across the device. When this occurs, the paired transistor may partially conduct at the wrong time. Add to this that PWM is sent along long cables to a motor that, in many applications, are inductors in the electrical sense, and this generates a perfect storm for someone not careful with their cable selection, grounding, shielding and connections.

Are there solutions? Absolutely! One can imagine that the complex model of an amplifier, cable, and motor are going to include inductance, resistance, capacitance, current, forward and BEMF voltages. This complex reactive load may not function as one thinks, but it is possible to resolve the issues if one knows where to look. A good model of the system may help. Once one determines if there is an issue, resolution techniques are to limit the oscillatory affects, and shield this cable with a magnetic shield and ground at both the source (amplifier) and at the motor terminations.

## When a Ground is Not a Ground

One of the most common direct coupled noise sources is when the ground which is being used for reference or return is not referenced to earth as expected. This is especially prevalent in sensitive high-gain circuits. An example is the power system where a neutral line is used. As can be seen from the drawing, the earth ground and the neutral are connected to the same potential at the power box. The difference is that neutral is a current carrying conductor. Should the signal be monitored at this point, one would not likely see voltage fluctuations on the neutral but the ground (By definition a non current carrying conductor). Should one inadvertently connect the power return of the line to ground instead of neutral, it would work but, besides being dangerous, it would likely put unintended noise on the ground line, negatively affecting all of the devices connected to it.

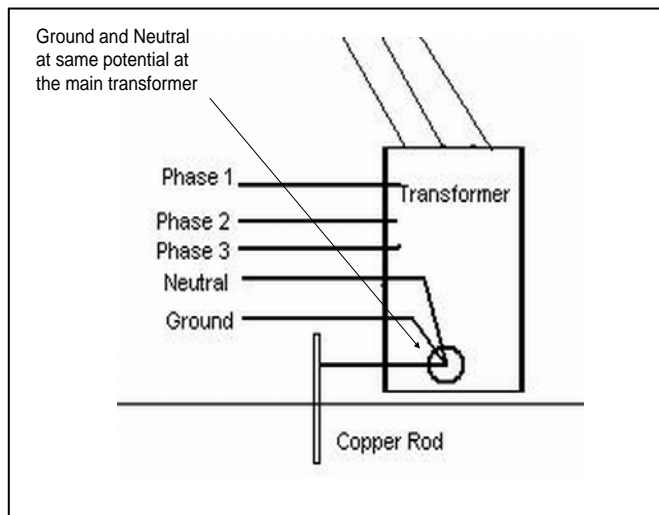

The Ground and Neutral are only at the same potential at the main transformer in a power distribution system

The solution is to connect the system correctly, but one should also filter the inputs of the sensitive devices from power line disturbance such as this. These power line disturbances are quite common and filters from Shaffner, APC, or similar sufficiently address this issue.

## PWM Simulation

The complex conditions for EMI noise are related but not limited to motor inductance, motor resistance cable capacitance, shielding and the capacitive effects of the windings. Add to this the unpredictable nature of what the PWM will do with BEMF voltages and the possibilities become more numerous. A model of the PWM technique is illustrated in the next column by way of an electronic simulation program.

To begin with, the motor's complex electrical characteristics are modeled as an inductor in series with the resistance of the motor. The motor's capacitance is lumped in with the cables and 1/3 of the bridge is modeled using IGBT's instead of the Intelligent Power Modules since they are identical in electrical characteristics, and represent one phase of the drive.

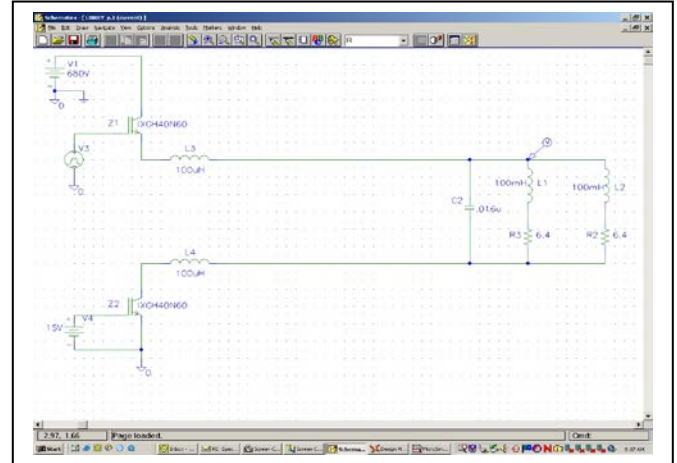

Schematic of PWM Drive with cable & motor winding representations

The standard simulation looks like ringing on the leading edge. It occurs at a substantially higher frequency than the PWM and is usually only on the rise time. Given this propensity to oscillate and the condition that each transistor will be doing this, it's easy to perceive how it can couple into a system when loaded by uneven RLC characteristics of the load. Common mode noise as well as voltage spikes on this dv/dt can cause electrical failure in the motor or the drive that can damage insulation.

This oscillation is prevalent on the PWM of all the transistors in the bridge. Any load imbalance results in current flow from the oscillation source to ground via this RLC circuit, essentially to ground. If it has a lower inductance path to ground it usually results in some of that leading edge leaking onto the signal returns. The attack has to be three fold to eliminate this. First, reduce the emissions. Second, shield the receiver to break the coupling. Third, force a current path to ground via the intended connections.

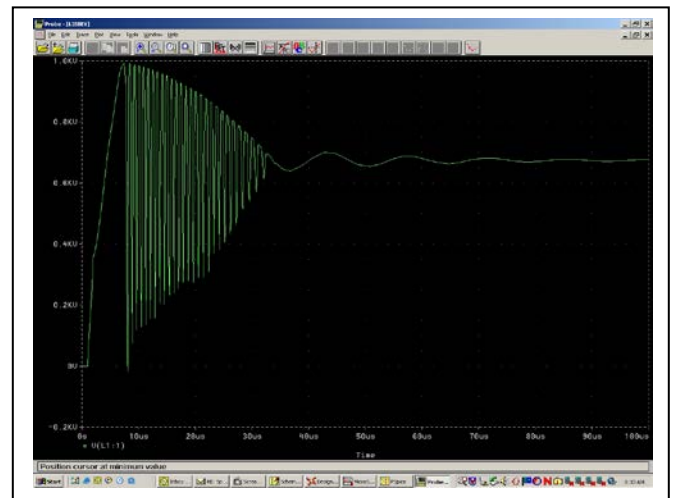

Standards Simulation showing PWM ringing

This drive model has an inductor added with a 100uH series inductance. The oscillation in the PWM shows that there is some behavior improvement but not enough to consider a

**GROUNDING AND SHIELDING EXISTING EQUIPMENT**

solution. While easier to shield than the original wild oscillation, there are some significant oscillations that could couple into the system. Reducing this further should be and is the goal here. However, with this amount of noise the drive did not cause problems, but it still wasn't considered right.

An alternative solution was to use a snubbing circuit as well. This would result in a very well controlled PWM pulse without the wild oscillating rising edge that can lead to EMI noise. The model included both a common mode inductor as well as a series mode that was matched to the cable capacitance. The benign oscillation of this PWM edge is unseen as noise in the system and was sufficient to be considered a solution. The problem encountered is that this type of circuit slows down the PWM resulting in the drive.

There is also a profound effect on the oscillation from the contribution of the cable. The combination of the cable capacitance and motor inductance can result in a "tank circuit" that can be resonant at a frequency relating to the rise time of the PWM. When this accidentally occurs there can be some catastrophic results.

As can be seen from the final model (bottom, right column), the bleeding as well as "covering the wound" can be taken care of with the shields, inductance and capacitance in the right area. This is the best solution with an existing design, with minimal impact on delivering a sound product.

**Component Selection is Important**

First and foremost, manufacturers that are CE compliant should have an intimate understanding of EMI and Electro-Magnetic Compatibility (EMC) compliance. Drives from manufacturers displaying the CE mark should be able to supply information to maintain compatibility as well as supply external products for special cases.

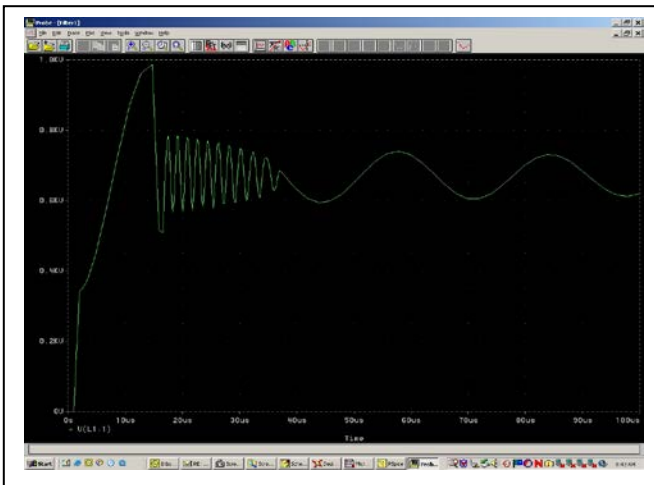

*The PWM snubbed with an insufficient common mode inductance*

Now with a good connection to ground and a lower frequency of the ringing, it's significantly easier to eliminate the noise. This could be shielded and grounded with a minimum effort. At this point, the noise is likely adequately minimized without significantly adding to system cost.

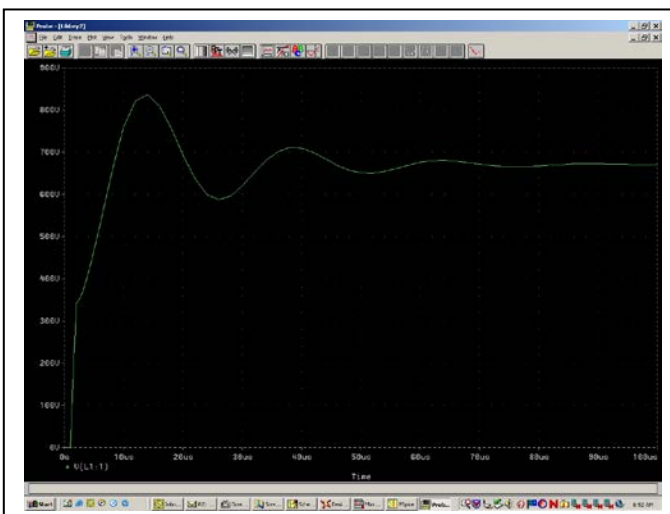

*The PWM snubbed with a sufficient common mode inductance*

## Conclusion

With some thought and armed with the knowledge of coupling mechanisms, users can be equipped to effectively minimize EMI issues when best practices are not available. When building electronic equipment, it is imperative to understand the coupling mechanisms of electrical noise that creates Electro-Magnetic Interference (EMI). It is also much easier to preplan a method of abatement during the build of a machine rather than try to initiate a resolution once the equipment is built.

### ABOUT KOLLMORGEN

Kollmorgen is a leading provider of motion systems and components for machine builders around the globe, with over 70 years of motion control design and application expertise.

Through world-class knowledge in motion, industry-leading quality and deep expertise in linking and integrating standard and custom products, Kollmorgen delivers breakthrough solutions unmatched in performance, reliability and ease-of-use, giving machine builders an irrefutable marketplace advantage.

For more information visit [www.kollmorgen.com](http://www.kollmorgen.com), email [support@kollmorgen.com](mailto:support@kollmorgen.com) or call 1-540-633-3545.