

AKM[®] Servo Motor

Selection Guide



with AKD[®] Family Servo Drive Systems

KOLLMORGEN

Kollmorgen: Your Partner, In Motion.

Every solution comes from a real understanding of the challenges facing machine designers and users.

Innovators consistently rate Kollmorgen as one of their best motion systems manufacturing partners. Whether you are looking for classic servo motors, direct-drive servo motors, stepper motors, drives & amplifiers, gearing, actuation, or multi-axis motion controllers, Kollmorgen is one of the few companies in the world that actually designs and manufactures all of these products.

Our customers are leaders in many industries such as Aerospace & Defense, Printing, Packaging & Converting, Food & Beverage Processing, Medical Imaging, In Vitro Diagnostics & Laboratory Automation, Pharmaceutical Manufacturing, Material Forming and Cutting, Oil & Gas, and Robotics. Kollmorgen is also a leader in Warehouse Automation, including complete AGV systems, software, awareness and autonomy.

Our Automation Solutions can be found on Mars and in space, ships and submarines, O&G drilling and metrology, surgical robots and laser eye surgery, even inside artificial hearts. These are just a few applications that demand high-performance and high-quality while satisfying their specific needs.

Because motion matters, it's our focus: Motion can distinctly differentiate a specific machine and deliver a marketplace advantage by increasing its performance and dramatically improving Overall Equipment Effectiveness (OEE).

High-performance motion can make your customer's machine more reliable and energy-efficient, enhance accuracy and improve operator safety. Motion also represents endless possibilities for innovation.

We've always understood this potential, and thus have kept motion at our core and in our Vision, Mission & Values, relentlessly developing products that offer precise control of torque, velocity and position accuracy in machines that rely on complex motion.

Removing the Barriers of Design, Sourcing, and Time

At Kollmorgen, we know that OEM engineers can achieve a lot more when obstacles aren't in the way. So, we clear obstacles in three important ways:

Integrating Standard and Custom Products

The optimal solution is often not clear-cut. Our application expertise allows us to modify standard products or develop totally custom solutions across our whole product portfolio so that designs can take flight.

Providing Motion Solutions, Not Just Components

As companies reduce their supplier base and focus their engineering manpower on the product design, they need a total system supplier with a wide range of integrated solutions. Kollmorgen offers complete solutions as well as motion subsystems that combine programming software, engineering services and best-in-class motion components.

Global Footprint

With direct sales, engineering support, manufacturing facilities, and distributors spanning the Americas, Europe, the Middle East, and Asia, we're close to OEMs worldwide. Our proximity helps speed delivery and lend support where and when they're needed.

Financial and Operational Stability

Kollmorgen is part of Altra Industrial Motion. A key driver in the growth of all Altra divisions is the Altra Business System, which relies on the principle of "kaizen" – or continuous improvement. Using world-class tools, cross-disciplinary teams of exceptional people evaluate processes and develop plans that result in superior performance.

Kollmorgen: Your partner. In Motion.

Trademarks

AKD is a registered trademark of Kollmorgen Corporation
 AKM is a registered trademark of Kollmorgen Corporation
 Cartridge DDR is a registered trademark of Kollmorgen Corporation
 EnDat is a registered trademark of Dr. Johannes Heidenhain GmbH
 EtherCAT is a registered trademark and patented technology, licensed by Beckhoff Automation GmbH
 Ethernet/IP is a registered trademark of ODVA, Inc.
 Ethernet/IP Communication Stack: copyright (c) 2009, Rockwell Automation
 sercos® is a registered trademark of sercos® international e.V.
 HIPERFACE and HIPERFACE DSL are registered trademarks of Max Stegmann GmbH
 PROFINET is a registered trademark of PROFIBUS and PROFINET International (PI)
 SIMATIC is a registered trademark of SIEMENS AG
 SpeedTec, ytec, itec and htec are registered trademarks of TE Connectivity Ltd.
 Windows is a registered trademark of Microsoft Corporation

Table of Contents

- ▶ **AKM® Servo Motor Family** **4**
- ▶ **AKM Model Nomenclature** **10**
- ▶ **AKM Servo Motor Quick Guide** **14**
- ▶ **AKM Servo Motor Specifications** **16**
 - AKM1x Performance Data 16
 - AKM1x Dimensional Drawings and Data 18
 - AKM2x Performance Data 20
 - AKM2x Dimensional Drawings and Data 22
 - AKM3x Performance Data 24
 - AKM3x Dimensional Drawings and Data 26
 - AKM4x Performance Data 28
 - AKM4x Dimensional Drawings and Data 32
 - AKM5x Performance Data 34
 - AKM5x Dimensional Drawings and Data 38
 - AKM6x Performance Data 40
 - AKM6x Dimensional Drawings and Data 44
 - AKM7x Performance Data 46
 - AKM7x Dimensional Drawings and Data 48
 - AKM8x Performance Data 50
 - AKM8x Dimensional Drawings and Data 52
- ▶ **Brake Option** **55**
- ▶ **L10 Bearing and Shaft Loading** **56**
- ▶ **Thermal Sensor Protective Device** **59**
- ▶ **Feedback Options** **60**
- ▶ **Servo Motor Feedback Combinations** **61**
- ▶ **AKM Servo Motor Connector Pinouts** **66**
- ▶ **Kollmorgen Cable Lookup Tables** **72**
- ▶ **AKD® Servo Drive Cable Lookup Tables** **76**
- ▶ **Cable Nomenclature** **78**
- ▶ **AKD 2G Servo Drive** **82**
- ▶ **AKD Servo Drive** **86**
- ▶ **AKD Servo Drive Nomenclature** **92**
- ▶ **Kollmorgen Solutions** **95**
 - Automation and Motion Control 95
 - Self-Help Tools 95

AKM[®] Servo Motor Family

Kollmorgen's AKM family of servo motors gives you unprecedented choice and flexibility from a wide range of standard products so you can select the best servo motor for your application.

With the broad range of AKM and AKM2G motors that support voltages up to 480 Vac, washdown, food grade, and the AKMH stainless steel hygienic motor for the toughest environments- Kollmorgen has a standard motor solution that can meet your needs right from the catalog.

Still need more? For your truly unique motion control applications, work with our engineering team to customize a solution for your machine design. Either way, standard product or customized, we can help you choose the motion control solution that meets your exact requirements.



The Benefits of AKM® Servo Motors

Best-in-Class Performance

- » Industry-leading motor power density
 - » Same size AKM/AKD system delivers up to 47% more shaft power
 - » Compensation for stiff and compliant transmissions and couplings
 - » Exceptionally low cogging
-

Flexibility to Find an Exact-fit Solution in a Standard Product

- » AKM offers 28 frame-stack combinations and 120 standard windings in a single motor line
 - » 4.8 million possible AKM part number combinations and growing
 - » Simplifies or eliminates mechanical modifications and engineering adaptation
 - » Available with single cable technology with digital feedback (Digital Resolver SFD3 or HIPERFACE® DSL)
 - » Washdown and Food Grade options for AKM
 - » Higher torque models up to 180 Nm of continuous torque
-

Ease-of-Use and Faster Commissioning

- » Plug-and-play motor recognition drive commissioning
 - » Reduce cycle time and sensor-and-wiring costs by eliminating traditional homing methods
 - » Reduction in set-up time for each servo system
-

AKM[®] Servo Motor Family

AKM Motors Offer Extremely High Torque Density and High Acceleration

The AKM high-performance motor series offers a wide range of mounting, connectivity, feedback and other options. These motors offer superb flexibility to meet application needs with:

- 8 frame sizes (40 to 260 mm)
- 28 frame-stack length combinations
- More than 120 standard windings



Features

Torque

0.16 to 180 Nm continuous stall torque (1.4 to 1590 lb-in) in 28 frame/stack combinations. Specific torques are often available from multiple frame sizes to optimize mounting and inertia matching capabilities.

Speed

Speeds up to 8000 rpm meet high speed application requirements. Windings tailored to lower speeds are also available.

Voltage

AKM motors can be applied to all standard global voltages. Windings are specifically tailored to work with drives powered by 75 Vdc, 120, 240, 400 or 480 Vac.

Mounting

Multiple mounting standards are available to meet common European, North American, and Japanese standards.

Feedback

AKM motors include resolver, encoder (commutating), Sine-Absolute encoder or SFD (Smart Feedback Device) feedback options to meet specific application requirements.

Smoothness

Smooth performance results from low-cog, low-harmonic distortion magnetic designs.

Connectivity

Rotatable IP65 connectors, straight IP67 connectors or low cost IP20 Molex plugs are both available to provide flexibility. Single connectors/plugs (combined power and feedback) are also available to minimize motor and cable cost (SFD and DSL only).

Thermal

Windings are rated conservatively at 100°C rise over a 40°C ambient while using 155°C (class F) insulation materials. Motors meet applicable UL, CSA, and CE requirements and include thermistors.

Additional Options:

- » Holding Brakes
- » Shaft and mounting variations
- » Shaft sealing options available
- » Custom windings
- » Feedback devices
- » Connectivity

Kollmorgen AKM Configurable Servo Motor Features

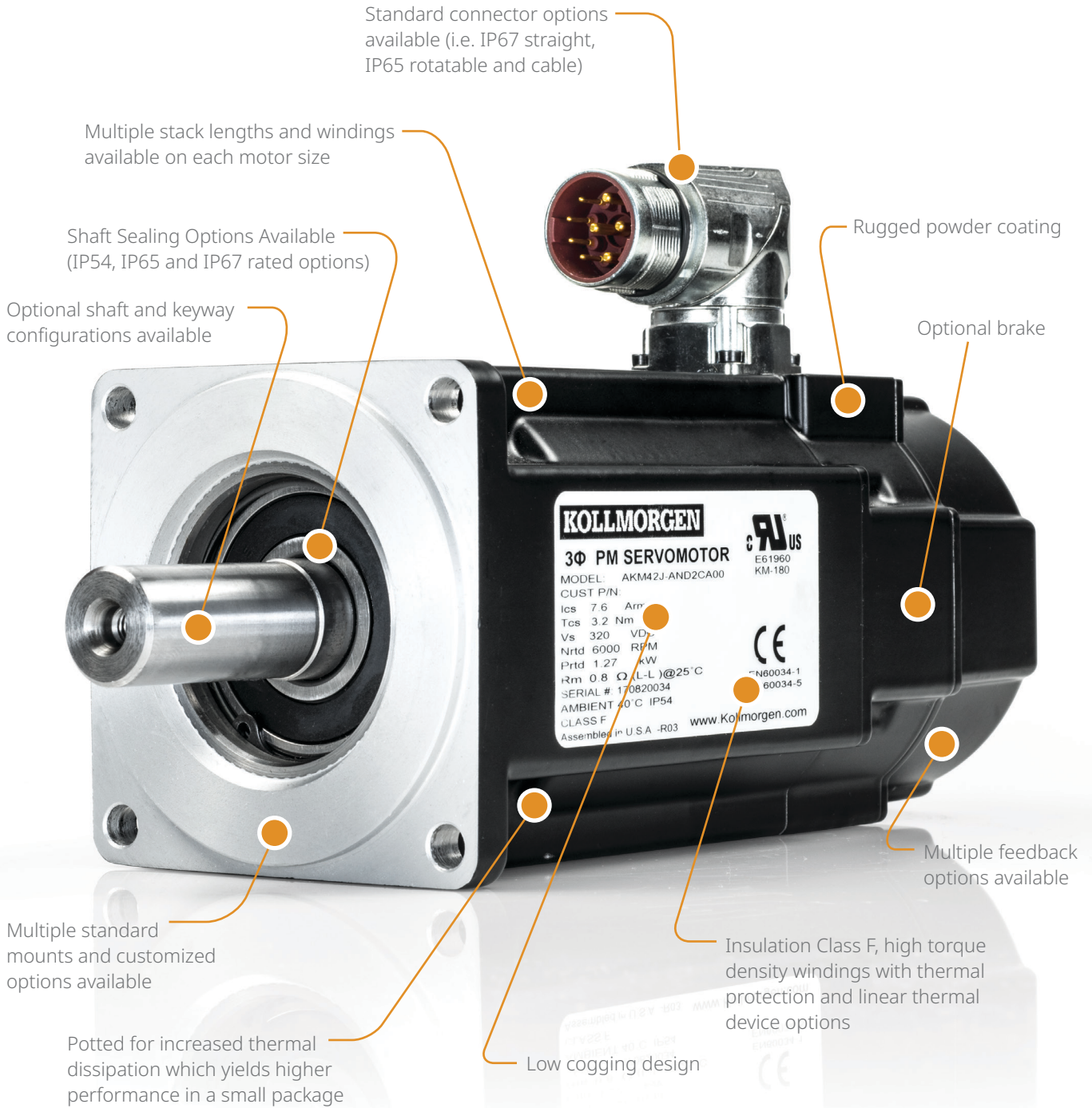

AKM[®] Servo Motor Family

Offering a broad power range along with durability and economy



AKM1

Flange: NEMA 17 / 40 mm
Power: 0.08 - 0.30 kW
Max Speed: 8000 RPM
Stacks: 3



AKM2

Flange: NEMA 23 / 58 mm
Power: 0.10 - 0.94 kW
Max Speed: 8000 RPM
Stacks: 4

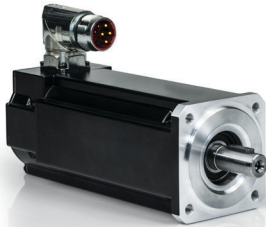

AKM3

Flange: 70 mm
Power: 0.09 - 1.31 kW
Max Speed: 8000 RPM
Stacks: 3



AKM4

Flange: NEMA 34 / 84 mm
Power: 0.21 - 1.73 kW
Max Speed: 6000 RPM
Stacks: 4



AKM5

Flange: NEMA 42 / 108 mm
Power: 0.56 - 3.87 kW
Max Speed: 6000 RPM
Stacks: 4



AKM6

Flange: 138 mm
Power: 1.17 - 6.24 kW
Max Speed: 6000 RPM
Stacks: 4

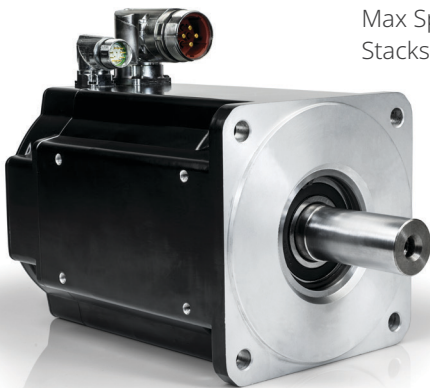

AKM7

Flange: 188 mm
Power: 3.97 - 8.58 kW
Max Speed: 6000 RPM
Stacks: 3

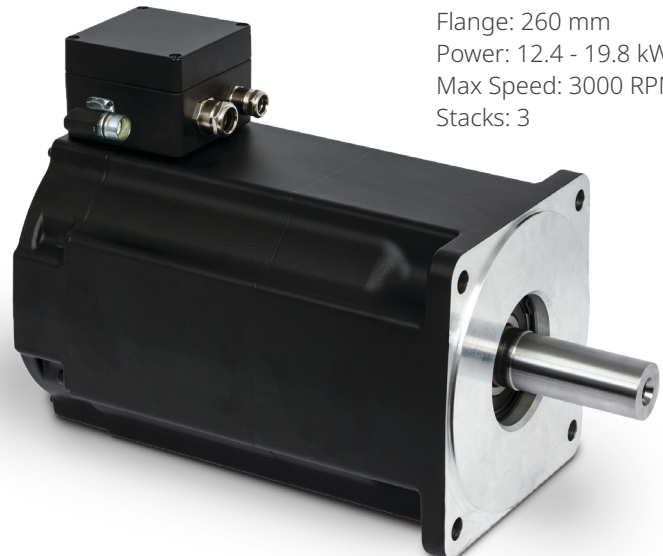

AKM8

Flange: 260 mm
Power: 12.4 - 19.8 kW
Max Speed: 3000 RPM
Stacks: 3

AKM® Washdown and Food Grade

These motor variants are used in applications that are subject to strict hygiene regulations in which it is essential that the formation of nuclei and corrosion are avoided and in which machines must be cleaned cyclically. These motors are based on the standard types AKM2 – AKM6 with special modifications for use in the food-processing industry, in the packaging industry, or even outdoors. An option for AKM Washdown and Food Grade motors is to coat the flange.

AKM® Washdown

Part Numbers:

AKMxxx-xxxxx-0W: Washdown with unpainted flange

AKMxxx-Wxxxx-0W: Washdown with painted flange

Note: The AKM Washdown motors must not come into contact with any unpacked food.

Application Area:	Harsh Environments, Outdoors
Application Examples:	Transport in the food and packaging area without contact with food, radar stations, and wind turbines
Standards:	UL, CE, RoHS
Surface:	Gray 2K paint
Immunity:	Against tested industrial cleaning agents*, corrosion-resistant
Degree of Protection:	IP67
Shaft:	303 Stainless steel (CSN417029)
Rotary Shaft Seal:	PTFE
Lubricant:	Industrial bearing grease, non-food-grade
Connector:	Stainless steel, smooth surface
Screws:	Stainless steel
Name Plate:	Engraved, additional name plate in the package



AKM® Food Grade

Part Numbers:

AKMxxx-xxxxx-0F: Food Grade with unpainted flange

AKMxxx-Wxxxx-0F: Food Grade with painted flange

Note: The surface of the AKM Food Grade food motor has passed all tests as per FDA Global Migration for indirect contact with food. Any direct contact with unpacked food is not permitted.

Application Examples:	Food and beverages industries; cutting, packing, and filling without direct contact with food; motor positioned laterally or below the food.
Standards:	UL, CE, RoHS, FDA
Surface:	White 2K FDA compliant paint**
Immunity:	Against tested industrial cleaning agents*, corrosion-resistant
Degree of Protection:	IP67
Shaft:	303 Stainless steel (CSN417029)
Rotary Shaft Seal:	PTFE as per FDA
Lubricant:	Food grade as per FDA
Connector:	Stainless steel, smooth surface
Screws:	Stainless steel
Name Plate:	Engraved, additional name plate in the package



* Resistance of the AKM Washdown and AKM Food Grade surfaces to the following industrial cleaning agents has been tested: P3-topactive DES, P3-topactive LA, P3-topax 56, P3-topax 66, P3-topax 91

**Meets FDA global migration standards

AKM® Model Nomenclature

AKM® Brushless Servo Motor

AKM 6 2 P - A N C N DA 00

AKM Series

Flange Size

- 1 40 mm
- 2 58 mm
- 3 70 mm
- 4 84 mm
- 5 108 mm
- 6 138 mm
- 7 188 mm
- 8 260 mm

Rotor Stack Length

		AKMx Availability							
		1	2	3	4	5	6	7	8
1	1 stack	•	•	•	•	•			
2	2 stacks	•	•	•	•	•	•	•	•
3	3 stacks	•	•	•	•	•	•	•	•
4	4 stacks		•		•	•	•	•	•
5	5 stacks						•		

1	1 stack	•	•	•	•	•			
2	2 stacks	•	•	•	•	•	•	•	•
3	3 stacks	•	•	•	•	•	•	•	•
4	4 stacks		•		•	•	•	•	•
5	5 stacks						•		

Winding Type

- A to Z
- S Special

Mount

- A IEC with tolerance N
- B NEMA
- C Alternative IEC standard
- D Other standard
- G Alternative IEC standard
- H Alternative IEC standard
- R IEC with tolerance R
- M, T Reinforced bearing AKM8
- W Flange coating for Washdown, IEC
- S Special

Shaft

- C Keyway
- K Open keyway
- N Smooth shaft
- S Special

Customization/Seal

- 00 Standard motor without shaft seal (IP54 rating)
- 01 With shaft seal (IP65 rating)
- 0F Food Grade (IP67 rating)
- 0W Washdown (IP67 rating)
- XX Customization

Feedback Device

- For all options see following page
- S Special

Brake

- 2 24 V holding brake
- N Without brake
- S Special

Connectors

- For all option details see following page
- B Dual 90° M23 Intercontec connectors, motor-mounted (AKM2 only)
- C Dual straight M23 Intercontec connectors, on 0.5 m shielded leads (AKM1-AKM2)
- C Dual 90° M23 Intercontec connectors, motor-mounted (AKM3-AKM7)
- D Single 90° M23 Intercontec connector, motor-mounted (AKM2-AKM4)
- 9 Single 90° itec connector, motor-mounted (AKM1 only)
- 9 Single 90° M23 Intercontec connector, motor-mounted (AKM2-AKM6)
- G Dual straight M23 Intercontec connector, motor-mounted (AKM2-AKM7)
- H Dual 90° M40 Intercontec connector and M23 Intercontec feedback connector, motor-mounted (AKM74QT & AKM82T)
- M Dual molex connectors, on 0.5 m shielded leads (AKM1-AKM4)
- P Single Molex connector, on 0.5 m shielded leads (AKM1-AKM4)
- T Dual terminal box for power and M23 Intercontec feedback connector, motor-mounted (AKM8)
- Y Single ytec connector, motor-mounted (AKM1 only)

Note: These connector options are only valid for the "00" and "01" customization/seal option variants. Stainless Steel Hummel connectors are used for AKM Washdown (0W) and AKM Food Grade (0F) variants.

Base Model	Mount-Shaft Availability																										
	AC	AK	AN	BK	BN	CC	CK	CN	DC	DK	DN	EF	EK	EN	GC	GN	HC	HN	KK	LK	MC	MN	TC	TN	WC	WN	
AKM1		•	•		•		•	•																			
AKM2	•		•		•		•	•		•	•			•											•	•	
AKM3	•		•		•		•	•																	•	•	
AKM4	•		•		•		•	•						•											•	•	
AKM5	•		•		•		•	•						•											•	•	
AKM6	•		•		•		•	•							•										•	•	
AKM7	•		•		•		•	•							•										•	•	
AKM8	•		•		•		•	•							•	•	•	•	•						•	•	

Note: Options shown in blue text are considered standard.

Feedback Unit Options

Feedback Unit Options				Feedback Resolution			Data Channel Resolution			
Code	AKM Frame Size	Designation	Single-Turn or Multi-Turn	Device Resolution (Sin/Cos per Rev., Bits or Lines/Rev.)	Max. Resolution after AKD Interpolation	Max. Resolution after AKD2G Interpolation	Accuracy (± arc-mins)	Position Values/Rev.	# of Absolute Revs.	
R-	1	Resolver	Single-Turn	1 pole pair (16-Bits)	16-Bits	16-Bits	15	16-Bits	1	
	2-4						10			
	5-8						9			
1-	2-8	Comcoder	Single-Turn	1024 Lines	4,096	4,096	1	Not Absolute	Not Absolute	
2-				2048 Lines	8,192	8,192				
ED				500 Lines	2,000	2,000				
EE				1000 Lines	4,000	4,000				
EF				2000 Lines	8,000	8,000				
EG				2500 Lines	10,000	10,000				
EH				5000 Lines	20,000	20,000				
EJ				10000 Lines	40,000	40,000				
EM				4096 Lines	16,384	16,384				
EN				8192 Lines	32,768	32,768				
AA				2-4	BiSS B Optical Sine Encoder	Single-turn				2048 Sin/Cos
	5-8	22-Bits (Max.)								
AB	2-4	Multi-turn	19-Bits (Max.)	4,096						
	5-8	22-Bits (Max.)								
C-	1	Smart Feedback Device (SFD)	Single-turn	24-Bits	24-Bits	24-Bits	15	24-Bits	1	
	2-4									8
	5-8									9
CA	1	Smart Feedback Device, Gen. 3 (SFD3)	Single-turn	24-Bits	24-Bits	24-Bits	15	24-Bits	1	
	2-4									8
	5-6									9
DA	2-4	EnDat 2.2/01 Optical Sine Encoder	Single-turn	512 Sin/Cos	25-Bits	32-Bits	1	13-Bits	1	
	5-8		2048 Sin/Cos	27-Bits	0.333					
DB	2-4		Multi-turn	512 Sin/Cos	25-Bits		1			
	5-8		2048 Sin/Cos	27-Bits	0.333		4,096			
LA	2-3	EnDat Inductive Encoder	Single-turn	16 Sin/Cos	20-Bits	28-Bits	4.67	18-Bits	1	
	4-8			32 Sin/Cos	21-Bits	29-Bits	3	19-Bits		
LB	2-3		Multi-turn	16 Sin/Cos	20-Bits	28-Bits	4.67	18-Bits	4,096	
	4-8			32 Sin/Cos	21-Bits	29-Bits	3	19-Bits		
GA/GJ*	2-8	HIPERFACE Optical Sin/Cos Encoder	Single-turn	128 Sin/Cos	23-Bits	31-Bits	1.33	12-Bits	1	
GB/GK*			Multi-turn						4,096	
GE	2-6	HIPERFACE DSL Optical Encoder	Single-turn	18-Bits	18-Bits	18-Bits	1.33	18-Bits	1	
GF			Multi-turn						4,096	
GP**	1	HIPERFACE Capacitive Encoder	Single-turn	16 Sin/Cos	20-Bits	28-Bits	4.8	9-Bits	1	
GR**			Multi-turn						4,096	

*ServoStar (Sxxx)/AKD mapped respectively

**AKD mapped ONLY

Note: See pages 60 to 65 for additional feedback specific information not found in this table.

Connector Options

Code	Thermal Sensor*	Used with	IP Rating**	Connection type	Description
B	PTC	AKM2	IP65	2 SpeedTec Ready connectors, size 1.0 (M23)	Angled, rotatable, mounted on motor
C	PTC	AKM1-AKM2	IP65	2 SpeedTec Ready connectors, size 1.0 (M23)	On 0.5m cable
C	PTC	AKM3-AKM7	IP65	2 SpeedTec Ready connectors, size 1.0 (M23)	Angled, rotatable, mounted on motor
D	PTC	AKM2-AKM4	IP65	1 SpeedTec Ready connector, size 1.0 (M23)	Angled, rotatable, mounted on motor
9	PT1000	AKM1	IP65	1 hybrid itec connector	Rotatable, mounted on motor
9	PT1000	AKM2-AKM6	IP65	1 SpeedTec Ready connector, size 1.0 (M23)	Angled, rotatable, mounted on motor
G	PTC	AKM2-AKM7	IP67	2 SpeedTec Ready connectors, size 1.0 (M23)	Straight, mounted on motor
H	PTC	AKM74Q & AKM82T	IP65	1 feedback threaded connector, size 1.0 (M23) 1 power threaded connector, size 1.5 (M40)	Angled, rotatable, mounted on motor
M	PTC	AKM1-AKM4	IP20	2 Molex connectors, $I_c < 6$ A	On 0.5m cable
P	PTC	AKM1-AKM4	IP20	1 Molex connector, $I_c < 6$ A	On 0.5m cable
T	PTC	AKM8	IP65	1 terminal box for power 1 feedback threaded connector, size 1.0 (M23)	Mounted on motor
Y	PTC	AKM1	IP65	1 ytec connector	Rotatable, mounted on motor

*For Thermal Device Curves, reference page 59.

**IP ratings shown apply ONLY to the connector and the connector base/bushing on motor.

NOTE: These connector options are only valid for the "00" or "01" Customization/Seal Option variants. Stainless Steel Hummel connectors are used for AKM Washdown (0W) and AKM Food Grade (0F) variants.

AKM® Model Nomenclature

Feedback and Connector Availability

AKM1		C	9	M	P	Y
Feedback Code	Connector Code R-	•		•		•
	1-, 2-	•		•		•
	Ex	•		•	•	•
	CA		•			
	GP, GR	•				•

AKM2		B	C	D	9	G	M	P
Feedback Code	Connector Code R-	•	•			•	•	
	1-, 2-	•	•			•	•	
	Ex	•	•			•	•	
	AA, AB	•	•			•	•	
	C-	•	•	•		•	•	•
	CA				•			
	DA, DB	•	•			•	•	
	LA, LB	•	•			•	•	
	GA, GB	•				•		
	GE, GF				•			
GJ, GK	•				•			

AKM3		C	D	9	G	M	P
Feedback Code	Connector Code R-	•			•	•	
	1-, 2-	•			•	•	
	Ex	•			•	•	
	AA, AB	•			•	•	
	C-	•	•		•	•	•
	CA			•			
	DA, DB	•			•	•	
	LA, LB	•			•	•	
	GA, GB	•			•		
	GE, GF			•			
GJ, GK	•			•			

AKM4		C	D	9	G	M	P
Feedback Code	Connector Code R-	•			•	•	
	1-, 2-	•			•	•	
	Ex	•			•	•	
	AA, AB	•			•	•	
	C-	•	•		•	•	•
	CA			•			
	DA, DB	•			•	•	
	LA, LB	•			•	•	
	GA, GB	•			•		
	GE, GF			•			
GJ, GK	•			•			

AKM5		C	9	G
Feedback Code	Connector Code R-	•		•
	1-, 2-	•		•
	Ex	•		•
	AA, AB	•		•
	C-	•		•
	CA		•	
	DA, DB	•		•
	LA, LB	•		•
	GA, GB	•		•
	GE, GF		•	
GJ, GK	•		•	

AKM6		C	9	G
Feedback Code	Connector Code R-	•		•
	1-, 2-	•		•
	Ex	•		•
	AA, AB	•		•
	C-	•		•
	CA		•	
	DA, DB	•		•
	LA, LB	•		•
	GA, GB	•		•
	GE, GF		•	
GJ, GK	•		•	

AKM7		C	G	H*
Feedback Code	Connector Code R-	•	•	•
	1-, 2-	•	•	•
	Ex	•	•	•
	AA, AB	•	•	•
	C-	•	•	•
	DA, DB	•	•	•
	LA, LB	•	•	•
	GA, GB	•	•	•
	GJ, GK	•	•	•

*AKM74Q Only

AKM8		H*	T
Feedback Code	Connector Code R-	•	•
	1-, 2-	•	•
	Ex	•	•
	AA, AB	•	•
	C-	•	•
	DA, DB	•	•
	LA, LB	•	•
	GJ, GK	•	•

*AKM82T Only

Notes

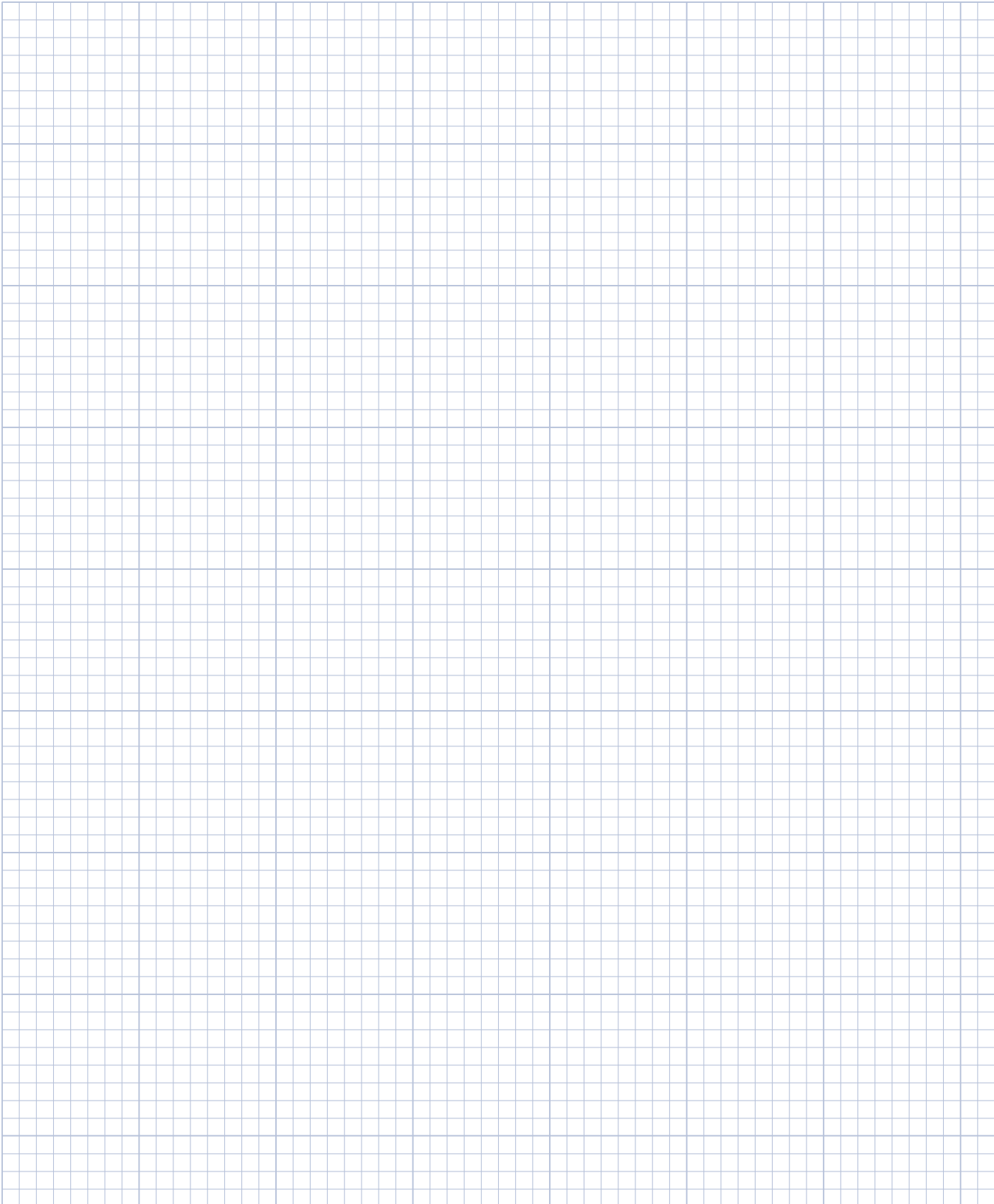

0.125 inch divisions

AKM[®] Servo Motor Quick Guide

AKM, AKM Washdown, and AKM Food Grade

Performance Data

AKM Servo Motor	Flange size [mm]	Cont. Torque at Stall Tcs [Nm]	Continuous Current I _c [A]	Peak Torque at stall Tps [Nm]	75 Vdc			120 Vac (160 Vdc)			240 Vac (320 Vdc)			400 Vac (560 Vdc)			480 Vac (640 Vdc)			Inertia (Jm) [kg·cm ²]	Weight [kg]
					Rated Speed N _{rt} d [RPM]	Rated Torque T _{rt} d [Nm]	Rated Power P _{rt} d [kW]	Rated Speed N _{rt} d [RPM]	Rated Torque T _{rt} d [Nm]	Rated Power P _{rt} d [kW]	Rated Speed N _{rt} d [RPM]	Rated Torque T _{rt} d [Nm]	Rated Power P _{rt} d [kW]	Rated Speed N _{rt} d [RPM]	Rated Torque T _{rt} d [Nm]	Rated Power P _{rt} d [kW]	Rated Speed N _{rt} d [RPM]	Rated Torque T _{rt} d [Nm]	Rated Power P _{rt} d [kW]		
11B	40	0.18	1.16	0.61	-	-	-	4000	0.18	0.08	8000	0.17	0.14	-	-	-	-	-	-	0.017	0.35
11C	40	0.18	1.45	0.61	-	-	-	6000	0.18	0.11	-	-	-	-	-	-	-	-	-	0.017	0.35
11E	40	0.18	2.91	0.61	6000	0.18	0.11	-	-	-	-	-	-	-	-	-	-	-	-	0.017	0.35
12C	40	0.31	1.51	1.08	-	-	-	4000	0.30	0.13	8000	0.28	0.23	-	-	-	-	-	-	0.031	0.49
12E	40	0.31	2.72	1.08	3000	0.31	0.10	8000	0.28	0.23	-	-	-	-	-	-	-	-	-	0.031	0.49
13C	40	0.41	1.48	1.46	-	-	-	3000	0.41	0.13	8000	0.36	0.30	-	-	-	-	-	-	0.045	0.63
13D	40	0.40	2.40	1.44	2000	0.40	0.08	7000	0.36	0.27	-	-	-	-	-	-	-	-	-	0.045	0.63
21C	58	0.48	1.58	1.47	-	-	-	2500	0.46	0.12	8000	0.39	0.32	-	-	-	-	-	-	0.11	0.82
21E	58	0.50	3.11	1.49	2000	0.48	0.10	7000	0.41	0.30	-	-	-	-	-	-	-	-	-	0.11	0.82
21G	58	0.50	4.87	1.51	4000	0.46	0.19	-	-	-	-	-	-	-	-	-	-	-	-	0.11	0.82
22C	58	0.84	1.39	2.73	-	-	-	1000	0.83	0.09	3500	0.78	0.29	8000	0.68	0.57	8000	0.68	0.57	0.16	1.10
22E	58	0.87	2.73	2.76	1000	0.85	0.09	3500	0.81	0.30	8000	0.70	0.59	-	-	-	-	-	-	0.16	1.10
22G	58	0.88	4.82	2.79	2500	0.83	0.22	7000	0.74	0.54	-	-	-	-	-	-	-	-	-	0.16	1.10
23C	58	1.13	1.41	3.77	-	-	-	1000	1.11	0.12	2500	1.08	0.28	5500	0.99	0.57	7000	0.95	0.70	0.22	1.38
23D	58	1.16	2.19	3.84	-	-	-	1500	1.12	0.18	5000	1.03	0.54	8000	0.92	0.77	8000	0.92	0.77	0.22	1.38
23E	58	1.16	2.78	3.86	-	-	-	2500	1.1	0.29	6500	0.98	0.67	-	-	-	-	-	-	0.22	1.38
23F	58	1.18	4.31	3.88	1500	1.15	0.18	4500	1.07	0.50	8000	0.94	0.79	-	-	-	-	-	-	0.22	1.38
24C	58	1.38	1.42	4.67	-	-	-	-	-	-	2000	1.32	0.28	4500	1.25	0.59	5500	1.22	0.70	0.27	1.66
24D	58	1.41	2.21	4.76	-	-	-	1500	1.36	0.21	4000	1.29	0.54	8000	1.11	0.93	8000	1.11	0.93	0.27	1.66
24E	58	1.40	2.79	4.79	-	-	-	2000	1.34	0.28	5500	1.24	0.71	-	-	-	-	-	-	0.27	1.66
24F	58	1.42	3.89	4.82	1000	1.39	0.15	3000	1.33	0.42	8000	1.12	0.94	-	-	-	-	-	-	0.27	1.66
31C	70	1.15	1.37	3.88	-	-	-	-	-	-	2500	1.12	0.29	5000	1.00	0.52	6000	0.91	0.57	0.33	1.55
31E	70	1.20	2.99	4.00	750	1.19	0.09	2500	1.17	0.31	6000	0.95	0.60	-	-	-	-	-	-	0.33	1.55
31H	70	1.23	5.85	4.06	2000	1.20	0.25	6000	0.97	0.61	-	-	-	-	-	-	-	-	-	0.33	1.55
32C	70	2.00	1.44	6.92	-	-	-	-	-	-	1500	1.95	0.31	3000	1.86	0.58	3500	1.83	0.67	0.59	2.23
32D	70	2.04	2.23	7.10	-	-	-	1000	2.00	0.21	2500	1.93	0.51	5500	1.65	0.95	6000	1.58	0.99	0.59	2.23
32E	70	2.04	2.82	7.11	-	-	-	-	-	-	3500	1.87	0.69	7000	1.41	1.03	7000	1.22	1.02	0.59	2.23
32H	70	2.10	5.50	7.26	1200	2.06	0.26	3000	1.96	0.62	7000	1.45	1.06	-	-	-	-	-	-	0.59	2.23
33C	70	2.71	1.47	9.76	-	-	-	-	-	-	1000	2.64	0.28	2000	2.54	0.53	2500	2.50	0.65	0.85	2.9
33E	70	2.79	2.58	9.96	-	-	-	-	-	-	2000	2.62	0.55	4500	2.34	1.10	5000	2.27	1.19	0.85	2.9
33H	70	2.88	5.62	10.22	800	2.82	0.24	2500	2.66	0.70	5500	2.27	1.31	-	-	-	-	-	-	0.85	2.9
41C	84	1.95	1.46	6.12	-	-	-	-	-	-	1200	1.88	0.24	3000	1.77	0.56	3500	1.74	0.64	0.81	2.44
41E	84	2.02	2.85	6.28	-	-	-	1200	1.94	0.24	3000	1.82	0.57	6000	1.58	0.99	6000	1.58	0.99	0.81	2.44
41H	84	2.06	5.6	6.36	1000	1.99	0.21	3000	1.86	0.58	6000	1.62	1.02	-	-	-	-	-	-	0.81	2.44
42C	84	3.35	1.40	11.3	-	-	-	-	-	-	-	-	-	1500	3.10	0.49	2000	3.02	0.63	1.5	3.39
42E	84	3.42	2.74	11.3	-	-	-	-	-	-	1800	3.12	0.59	3500	2.81	2.35	4000	2.72	1.14	1.5	3.39
42G	84	3.53	4.80	11.5	-	-	-	-	-	-	3500	2.90	1.06	6000	2.35	1.48	6000	2.35	1.48	1.5	3.39
42H	84	3.54	6	13.34	-	-	-	2000	3.2	0.67	-	-	-	-	-	-	-	-	-	1.5	3.39
42J	84	3.56	8.4	11.6	-	-	-	3000	3.03	0.95	6000	2.36	1.50	-	-	-	-	-	-	1.5	3.39
43E	84	4.70	2.76	15.9	-	-	-	-	-	-	1500	4.24	0.67	2500	3.92	1.03	3000	3.76	1.18	2.1	4.35
43G	84	4.80	4.87	16.1	-	-	-	-	-	-	2500	4.00	1.05	5000	3.01	1.58	6000	2.57	1.61	2.1	4.35
43H	84	4.82	3.86	16.1	-	-	-	1200	4.46	0.56	3000	3.86	1.21	5500	2.81	1.62	6000	2.58	1.62	2.1	4.35
43K	84	4.90	9.60	16.4	-	-	-	2500	4.08	1.07	6000	2.62	1.65	-	-	-	-	-	-	2.1	4.35
43L	84	4.73	3.78	16.0	-	-	-	3000	3.78	1.19	6000	2.53	1.59	-	-	-	-	-	-	2.1	4.35
44E	84	5.76	2.90	19.9	-	-	-	-	-	-	1200	5.22	0.66	2000	4.80	1.01	2500	4.56	1.19	2.7	5.3
44G	84	5.88	5.00	20.2	-	-	-	-	-	-	2000	4.90	1.03	4000	3.76	1.57	5000	3.19	1.67	2.7	5.3
44H	84	5.89	5.6	20.0	-	-	-	1000	5.44	0.57	2500	4.66	1.22	4500	3.48	1.64	5500	2.93	1.69	2.7	5.3
44J	84	6.00	8.80	20.4	-	-	-	-	-	-	4000	3.84	1.61	6000	2.75	1.73	6000	2.75	1.73	2.7	5.3
44K	84	5.88	10.1	23.7	-	-	-	2500	4.08	1.38	5000	3.18	1.67	-	-	-	-	-	-	2.7	6.3
51E	108	4.70	2.75	11.6	-	-	-	-	-	-	1200	4.41	0.55	2500	3.98	1.04	3000	3.80	1.19	3.4	4.2
51G	108	4.75	4.84	11.7	-	-	-	-	-	-	2500	4.02	1.05	5000	2.62	1.37	6000	1.94	1.22	3.4	4.2
51H	108	4.79	6.00	11.7	-	-	-	-	-	-	3000	3.87	1.22	6000	1.95	1.23	6000	1.95	1.23	3.4	4.2
51K	108	4.90	9.40	11.9	-	-	-	2500	4.15	1.09	5500	2.35	1.35	-	-	-	-	-	-	3.4	4.2
51L	108	4.89	11.9	12	-	-	-	3000	3.95	1.24	6000	2.00	1.26	-	-	-	-	-	-	3.4	4.2

Performance curves can be generated using our online Performance Curve Generator Tool: <https://pcgh.kollmorgen.com/>

Performance Data (continued)

AKM Servo Motor	Frame size [mm]	Cont. Torque at Stall Tcs [Nm]	Continuous Current I _c [A]	Peak Torque at stall Tps [Nm]	120 Vac (160 Vdc)			240 Vac (320 Vdc)			400 Vac (560 Vdc)			480 Vac (640 Vdc)			Inertia (Jm) [kg·cm ²]	Weight [kg]
					Rated Speed Nrtd [RPM]	Rated Torque Trtd [Nm]	Rated Power Prtd [kW]	Rated Speed Nrtd [RPM]	Rated Torque Trtd [Nm]	Rated Power Prtd [kW]	Rated Speed Nrtd [RPM]	Rated Torque Trtd [Nm]	Rated Power Prtd [kW]	Rated Speed Nrtd [RPM]	Rated Torque Trtd [Nm]	Rated Power Prtd [kW]		
52E	108	8.34	2.99	21.3	-	-	-	-	-	-	1500	7.61	1.20	2000	7.28	1.52	6.2	5.8
52G	108	8.43	4.72	21.5	-	-	-	1200	7.69	1.21	2500	7.06	1.85	3000	6.66	2.09	6.2	5.8
52H	108	8.48	5.90	21.6	-	-	-	1800	7.53	1.42	3500	6.26	2.30	4000	5.77	2.42	6.2	5.8
52K	108	8.60	9.30	21.9	-	-	-	3000	6.80	2.14	5500	3.90	2.25	6000	3.25	2.04	6.2	5.8
52L	108	8.67	11.6	22.0	1500	7.89	1.24	3500	6.40	2.35	6000	3.27	2.06	6000	3.27	2.03	6.2	5.8
52M	108	8.60	13.1	21.9	-	-	-	4500	5.20	2.45	-	-	-	-	-	-	6.2	5.8
53G	108	11.4	4.77	29.7	-	-	-	1000	10.7	1.12	2000	9.85	2.06	2400	9.50	2.39	9.1	7.4
53H	108	11.5	6.60	30.0	-	-	-	-	-	-	3000	8.63	2.77	3500	8.23	3.02	9.1	7.4
53K	108	11.6	9.40	30.3	-	-	-	2000	10.1	2.12	4000	7.65	3.20	4500	6.85	3.23	9.1	7.4
53L	108	11.6	11.8	30.3	1200	13.0	1.63	2500	9.59	2.51	5000	6.00	3.14	6000	4.05	2.55	9.1	7.4
53M	108	11.4	13.4	29.7	-	-	-	3000	8.72	2.74	-	-	-	-	-	-	9.1	7.4
53P	108	11.4	19.1	29.8	-	-	-	5000	5.88	3.08	-	-	-	-	-	-	9.1	7.4
53Q	108	11.57	21.1	42.6	2500	9.58	2.51	5500	4.99	2.87	-	-	-	-	-	-	9.1	7.4
54G	108	14.3	5.00	38.0	-	-	-	-	-	-	1500	12.9	2.03	2000	12.3	2.57	12	9
54H	108	14.2	5.50	37.5	-	-	-	-	-	-	1500	12.6	2.38	2000	12.2	2.56	12	9
54K	108	14.4	9.7	38.4	-	-	-	1800	12.7	2.39	3500	10.0	3.68	4000	9.25	3.87	12	9
54L	108	14.1	12.5	37.5	-	-	-	2500	11.5	3.00	4500	8.13	3.83	-	-	-	12	9
54N	108	14.1	17.8	37.6	-	-	-	3500	9.85	3.61	-	-	-	-	-	-	12	9
54P	108	14.36	19.6	54.5	-	-	-	4000	9.23	3.87	-	-	-	-	-	-	12	9
62G	138	11.9	4.9	29.7	-	-	-	-	-	-	1800	10.4	1.96	2000	10.2	2.14	17	8.9
62H	138	11.9	5.4	29.6	-	-	-	1000	10.8	1.17	2000	10.2	2.14	2400	9.9	2.49	17	8.9
62K	138	12.2	9.6	30.2	-	-	-	2000	10.4	2.18	3500	9.00	3.30	4500	8.00	3.77	17	8.9
62L	138	12.2	12.0	30.1	-	-	-	2500	10.0	2.62	5000	7.42	3.89	6000	5.74	3.61	17	9.8
62M	138	12.2	13.4	30.2	-	-	-	3000	9.50	2.98	6000	5.70	3.58	6000	5.70	3.58	17	8.9
62P	138	12.3	18.8	30.3	-	-	-	4500	8.10	3.82	-	-	-	-	-	-	17	8.9
62Q	138	12.0	21.8	29.8	-	-	-	5500	6.5	3.74	-	-	-	-	-	-	17	8.9
63G	138	16.5	4.5	42.1	-	-	-	-	-	-	1200	14.9	1.87	1500	14.6	2.29	24	11.1
63H	138	16.6	5.6	42.1	-	-	-	-	-	-	1500	14.6	2.29	1800	14.2	2.68	24	11.1
63K	138	16.8	9.9	42.6	-	-	-	1500	14.9	2.34	3000	12.9	4.05	3500	12.0	4.40	24	11.1
63L	138	16.8	11.1	42.6	-	-	-	1500	14.2	2.23	3000	12.9	4.05	3500	12	4.4	24	11.1
63M	138	17.0	13.8	43.0	-	-	-	2000	14.3	2.99	4000	11.3	4.73	4500	10.5	4.95	24	11.1
63N	138	17.0	17.4	43.0	-	-	-	3000	13.0	4.08	5000	9.60	5.03	6000	7.00	4.40	24	11.1
63Q	138	16.7	22.4	42.4	-	-	-	3500	11.9	4.36	-	-	-	-	-	-	24	11.1
64K	138	20.8	9.2	53.5	-	-	-	1200	18.8	2.36	2000	17.2	3.60	2500	16.3	4.27	32	13.3
64L	138	21.0	12.8	54.1	-	-	-	1500	18.4	2.89	3000	15.6	4.90	3500	14.4	5.28	32	13.3
64P	138	20.4	18.6	52.9	-	-	-	2500	16.0	4.19	4500	11.9	5.62	5500	9.00	5.18	32	13.3
64Q	138	20.0	20.7	53.2	-	-	-	3000	15.3	4.81	5000	10.7	6.45	6000	7.40	4.65	32	13.3
65K	138	24.8	9.8	64.5	-	-	-	1000	22.8	2.39	2000	20.2	4.23	2200	19.7	4.54	40	15.4
65L	138	25.0	12.2	65.2	-	-	-	1300	22.4	3.05	2500	19.2	5.03	2800	18.6	5.37	40	15.4
65M	138	25.0	13.6	65.2	-	-	-	1500	21.9	3.44	2500	19.2	5.03	3000	18.1	5.69	40	15.4
65N	138	24.3	17.8	63.7	-	-	-	2000	19.8	4.15	3500	16.0	5.86	4000	14.7	6.16	40	15.4
65P	138	24.5	19.8	64.1	-	-	-	2400	19.1	4.8	4000	14.9	6.24	5000	11.6	6.08	40	15.4
72K	188	29.7	9.3	79.4	-	-	-	-	-	-	1500	25.1	3.94	1800	24.0	4.52	65	19.7
72L	188	30	11.5	79.5	-	-	-	-	-	-	1500	25.3	3.97	1800	24.3	4.58	65	19.7
72M	188	30.0	13.0	79.8	-	-	-	-	-	-	2000	23.6	4.94	2500	22.1	5.79	65	19.7
72P	188	29.4	18.7	78.5	-	-	-	1800	23.8	4.49	3000	20.1	6.31	3500	18.2	6.67	65	19.7
72Q	188	29.5	23.5	78.4	-	-	-	2000	23.2	4.89	4000	16.3	6.83	4500	14.1	6.65	65	19.7
73L	188	42.0	12.1	113	-	-	-	-	-	-	1400	34.4	5.04	1500	33.8	5.31	92	26.7
73M	188	42.0	13.6	112	-	-	-	-	-	-	1500	33.8	5.31	1800	32.1	6.05	92	26.7
73P	188	41.6	19.5	111	-	-	-	1300	34.7	4.72	2400	28.5	7.16	2800	26.3	7.71	92	26.7
73Q	188	41.5	24.5	111	-	-	-	1500	33.4	5.25	3000	25.2	7.92	3500	22	8.07	92	26.7
74L	188	53.0	12.9	143	-	-	-	-	-	-	1200	43.5	5.47	1400	41.5	6.08	120	33.6
74P	188	52.5	18.5	142	-	-	-	-	-	-	1800	39.6	7.46	2000	35.9	7.52	120	33.6
74Q	188	52.2	26.1	141	-	-	-	1300	41.9	5.71	2500	31.5	8.25	3000	27.3	8.58	120	33.6
82T	260	75	48	210	-	-	-	-	-	-	2500	47.5	12.4	3000	38.0	11.9	172	49
83T	260	130	62	456	-	-	-	-	-	-	2200	70.0	16.1	2500	60.0	15.7	334	73
84T	260	180	67	668	-	-	-	-	-	-	1800	105	19.8	2000	93.0	19.5	495	97

Performance curves can be generated using our online Performance Curve Generator Tool: <https://pcgh.kollmorgen.com/>

AKM[®] Servo Motor Specifications

AKM1x Performance Data – Up to 240 Vac (320 Vdc Bus) voltage

Parameters	Tol	Symbol	Units	AKM11			AKM12		AKM13	
				B	C	E	C	E	C	D
Max Rated Voltage ⑩	Max	-	Vac	240	120	-	240	120	240	120
			Vdc	320	160	75	320	160	320	160
Continuous Torque (Stall) for ΔT winding = 100°C ①②⑦⑧	Nom	T _{CS}	Nm	0.183	0.185	0.185	0.310	0.310	0.409	0.401
			Ib-in	1.62	1.64	1.64	2.74	2.74	3.62	3.55
Continuous Current (Stall) for ΔT winding = 100°C ①②⑦⑧	Nom	I _{CS}	A _{RMS}	1.16	1.45	2.91	1.51	2.72	1.48	2.40
Continuous Torque (Stall) for ΔT winding = 60°C ②	Nom	T _{CS}	Nm	0.146	0.148	0.148	0.248	0.248	0.327	0.320
			Ib-in	1.29	1.31	1.31	2.19	2.19	2.89	2.83
Max Mechanical Speed ⑤	Nom	N _{max}	rpm	8000	8000	8000	8000	8000	8000	8000
Peak Torque ①②	Nom	T _p	Nm	0.609	0.614	0.611	1.08	1.08	1.46	1.44
			Ib-in	5.39	5.43	5.41	9.6	9.6	12.9	12.7
Peak Current	Nom	I _p	A _{RMS}	4.65	5.79	11.6	6.06	10.9	5.93	9.6
Rated Torque (speed) ①②⑦⑧		T _{rtd}	Nm	-	-	0.176	-	0.309	-	0.401
			Ib-in	-	-	1.56	-	2.73	-	3.55
Rated Speed		N _{rtd}	rpm	-	-	6000	-	3000	-	2000
Rated Power (speed) ①②⑦		P _{rtd}	kW	-	-	0.11	-	0.10	-	0.08
			Hp	-	-	0.15	-	0.13	-	0.11
Rated Torque (speed) ①②⑦⑧		T _{rtd}	Nm	0.180	0.176	-	0.304	0.279	0.407	0.365
			Ib-in	1.59	1.56	-	2.69	2.47	3.60	3.23
Rated Speed		N _{rtd}	rpm	4000	6000	-	4000	8000	3000	7000
Rated Power (speed) ①②⑦		P _{rtd}	kW	0.08	0.11	-	0.13	0.23	0.13	0.27
			Hp	0.10	0.15	-	0.17	0.31	0.17	0.36
Rated Torque (speed) ①②⑦⑧		T _{rtd}	Nm	0.167	-	-	0.279	-	0.364	-
			Ib-in	1.48	-	-	2.47	-	3.22	-
Rated Speed		N _{rtd}	rpm	8000	-	-	8000	-	8000	-
Rated Power (speed) ①②⑦		P _{rtd}	kW	0.14	-	-	0.23	-	0.30	-
			Hp	0.19	-	-	0.31	-	0.41	-
Rated Torque (speed) ①②⑦⑧		T _{rtd}	Nm	-	-	-	-	-	-	-
			Ib-in	-	-	-	-	-	-	-
Rated Speed		N _{rtd}	rpm	-	-	-	-	-	-	-
Rated Power (speed) ①②⑦		P _{rtd}	kW	-	-	-	-	-	-	-
			Hp	-	-	-	-	-	-	-
Rated Torque (speed) ①②⑦⑧		T _{rtd}	Nm	-	-	-	-	-	-	-
			Ib-in	-	-	-	-	-	-	-
Rated Speed		N _{rtd}	rpm	-	-	-	-	-	-	-
Rated Power (speed) ①②⑦		P _{rtd}	kW	-	-	-	-	-	-	-
			Hp	-	-	-	-	-	-	-

See following page for notes.

AKM1x Performance Data – Up to 240 Vac (320 Vdc Bus) voltage (Continued)

Parameters	Tol	Symbol	Units	AKM11			AKM12		AKM13	
				B	C	E	C	E	C	D
Torque Constant ①	±10%	K _t	Nm/A _{rms}	0.158	0.129	0.064	0.207	0.112	0.278	0.169
			lb-in/A _{rms}	1.40	1.14	0.57	1.83	0.99	2.46	1.50
Back EMF Constant ⑥	±10%	K _e	V _{rms} /krpm	10.2	8.3	4.1	13.3	7.2	17.9	10.9
Motor Constant	Nom	K _m	N-m/√W	0.0302	0.0303	0.0296	0.0480	0.0463	0.0618	0.0593
			lb-in/√W	0.267	0.268	0.262	0.425	0.410	0.547	0.525
Resistance (line-line) ⑥	±10%	R _m	ohm	18.23	12.11	3.11	12.4	3.9	13.5	5.41
Inductance (line-line)		L	mH	12.5	8.3	2.04	9.1	2.7	10.3	3.8
Inertia (includes Resolver feedback) ③	±10%	J _m	kg-cm ²	0.017			0.031		0.045	
			lb-in-s ²	1.5E-05			2.7E-05		4.0E-05	
Optional Brake Inertia (additional)	±10%	J _m	kg-cm ²	0.0013			0.0013		0.0013	
			lb-in-s ²	0.12E-05			0.12E-05		0.12E-05	
Weight (w/o brake) ⑨		W	kg	0.35			0.49		0.63	
			lb	0.8			1.1		1.4	
Static Friction ①⑧		T _f	Nm	0.0011			0.0021		0.0031	
			lb-in	0.01			0.02		0.03	
Viscous Damping ①		K _{dv}	Nm/krpm	0.0005			0.001		0.0015	
			lb-in/krpm	0.004			0.009		0.013	
Thermal Time Constant		TCT	minutes	4			6		7	
Thermal Resistance		R _{thw-a}	°C/W	1.83			1.63		1.53	
Operating Ambient Temperature Range ⑩ ⑫ ⑬			°C	-20 to 40			-20 to 40		-20 to 40	
Pole Pairs				3			3		3	
Heat Sink Size				10"x10"x1/4" Aluminum Plate			10"x10"x1/4" Aluminum Plate		10"x10"x1/4" Aluminum Plate	

Notes:

- ① Motor winding temperature rise, ΔT=100°C, at 40°C ambient.
- ② All data referenced to sinusoidal commutation.
- ③ Add parking brake if applicable for total inertia.
- ④ Motor with standard heat sink.
- ⑤ May be limited at some values of V_{bus}.
- ⑥ Measured at 25°C.
- ⑦ For non-resolver feedback options: no continuous torque reduction.
- ⑧ For motors with optional shaft seal, reduce torque shown by 0.021 Nm (0.19 lb-in), and increase T_f by the same amount.
- ⑨ Brake option increases weight by 0.19 kg (0.42 lb).
- ⑩ Motors can be operated up to 240 Vac. For performances curves at voltages, listed or unlisted, please use our online [Performance Curve Generator Tool](#).
- ⑪ Brake option will operate in this range in a non-condensing environment. See page 55 for more information.
- ⑫ "AA" or "AB" BiSS feedback lower limit is -15°C; all other feedbacks meet or exceed this range.
- ⑬ Operation outside of this range may be possible. Please contact Kollmorgen Customer Support with your application requirements.

Additional Notes:

See system data beginning on page 14 for typical torque/speed performance.
 Performance curves can be generated using our online Performance Curve Generator Tool: <https://pcgh.kollmorgen.com/>
 Additional windings may exist. Please contact Kollmorgen Customer Support for further information or to request custom winding options for your application requirements.

*Complete AKM series model nomenclature can be found on pages 10-12.

AKM[®] Servo Motor Specifications

AKM1x Frame Dimensional Drawings

AKM 2D/3D CAD models can be found here: [AKM CAD Models](#)

C-, M-, P- connector options

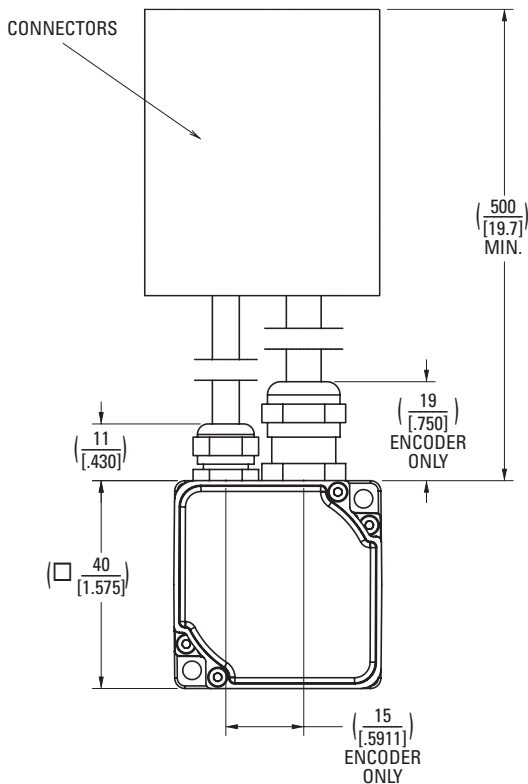
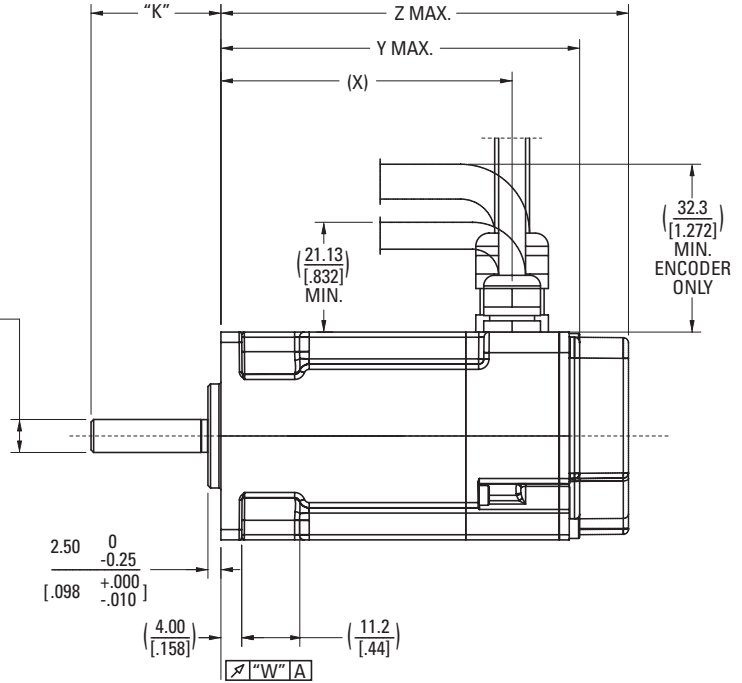
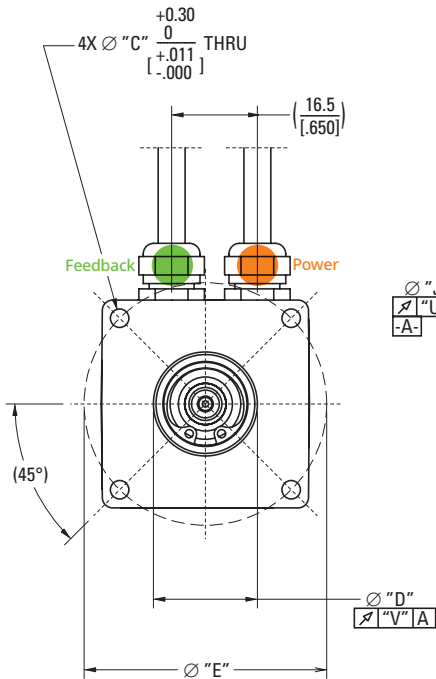

ytec Y- connector option

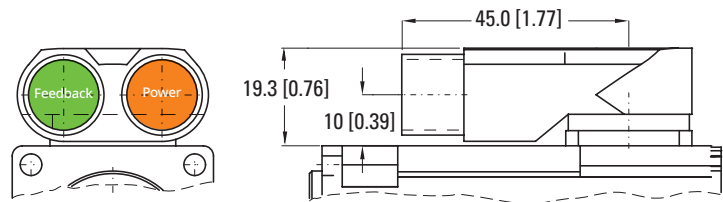

itec 9- connector option

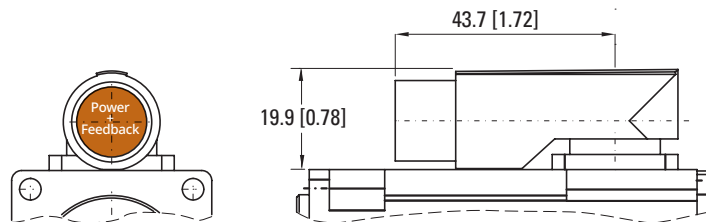

Shaft-keyway dimensions

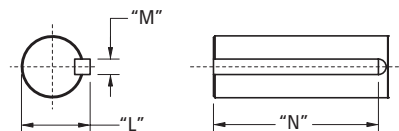

Dimensional data tables for callouts are located on the following page.

AKM1x Mounting Flange-Shaft Dimensional Data

Mounting Flange-Shaft	Hole Diameter "C"	Pilot Diameter "D"	Bolt Circle Dia. "E"	"F"	"H"	Shaft Diameter "J"	Shaft Length "K"
AK	4.30 [0.169]	30 [1.1811]	46 [1.811]	-	-	8 [0.3150]	25 [0.984]
AN	4.30 [0.169]	30 [1.1811]	46 [1.811]	-	-	8 [0.3150]	25 [0.984]
BN	3.56 [0.140]	20.02 [0.788]	46.69 [1.838]	-	-	6.350 [0.2500]	25 [0.984]
CK	3.40 [0.134]	30 [1.1811]	45 [1.772]	-	-	8 [0.3150]	25 [0.984]
CN	3.40 [0.134]	30 [1.1811]	45 [1.772]	-	-	8 [0.3150]	25 [0.984]

Mounting Flange-Shaft	Shaft Dia. w/ Key "L"	Key Width "M"	Key Length "N"
AK	9.20 [0.362]	3 [0.1181]	14 [0.551]
AN	-	-	-
BN	-	-	-
CK	9.20 [0.362]	3 [0.1181]	14 [0.551]
CN	-	-	-

AKM1x Motor Length Dimensional Data

Connector	No Brake (N)						
	X		Y MAX		Z MAX		
	C-, M-, P-	Y-, 9-	C- M-	Y- 9-	C-, M-, P-	Y-	
Feedback Option	R, C-, 1-, 2-, Gx	R-, C-, CA 1-, 2-, Gx	R-	R-, C-, CA-, 1-, 2-	C-, 1-, 2-	Gx	Gx
AKM11	56.1 [2.21]	60.8 [2.39]	69.6 [2.74]	79 [3.11]	79 [3.11]	88.5 [3.48]	
AKM12	75.1 [2.96]	79.8 [3.14]	88.6 [3.49]	98 [3.86]	98 [3.86]	107.5 [4.23]	
AKM13	94.1 [3.7]	98.8 [3.89]	107.6 [4.24]	117 [4.61]	117 [4.61]	126.5 [4.98]	

Connector	Brake (2)						
	X			Y MAX		Z MAX	
	C-, M-, P-	C-, M-	Y-, 9-	C-, M-	Y-, 9-	C-, M-, P-	Y-, 9-
Feedback Option	R-, C-, Gx	1-, 2-	R-, C-, CA 1-, 2-, Gx	R-		C-, 1-, 2-, Gx	C-, CA-, 1-, 2-, Gx
AKM11	96.2 [3.79]	98.2 [3.86]	96.2 [3.79]	115.6 [4.55]		125 [4.92]	
AKM12	115.2 [4.54]	117.2 [4.61]	115.2 [4.54]	134.6 [5.3]		144 [5.67]	
AKM13	134.2 [5.28]	136.2 [5.28]	134.2 [5.28]	153.6 [6.05]		163 [6.42]	

Note 1: Dimensions are in mm [inches].

Note 2: Detailed Connector and Feedback option information can be found on pages 11-12.

Note 3: Product designed in metric. English conversions provided for reference only.

*Complete AKM series model nomenclature can be found on pages 10-12.

AKM[®] Servo Motor Specifications

AKM2x Performance Data – Up to 480 Vac (640 Vdc Bus) voltage

Parameters	Tol	Symbol	Units	AKM21			AKM22			AKM23				AKM24			
				C	E	G	C	E	G	C	D	E	F	C	D	E	F
Max Rated Voltage ⑥	Max	-	Vac	240	120	-	480	240	120	480	480	240	240	480	480	240	240
			Vdc	320	160	75	640	320	160	640	640	320	320	640	640	320	320
Continuous Torque (Stall) for ΔT winding = 100°C ①②⑦⑧⑨	Nom	T _{CS}	Nm	0.48	0.50	0.50	0.84	0.87	0.88	1.13	1.16	1.16	1.18	1.38	1.41	1.40	1.42
			lb-in	4.2	4.4	4.4	7.4	7.7	7.8	10	10.3	10.3	10.4	12.2	12.5	12.4	12.6
Continuous Current (Stall) for ΔT winding = 100°C ①②⑦⑧⑨	Nom	I _{CS}	A _{RMS}	1.58	3.11	4.87	1.39	2.73	4.82	1.41	2.19	2.78	4.31	1.42	2.21	2.79	3.89
Continuous Torque (Stall) for ΔT winding = 60°C ②	Nom	T _{CS}	Nm	0.38	0.40	0.40	0.67	0.70	0.70	0.904	0.92	0.93	0.94	1.104	1.13	1.12	1.14
			lb-in	3.4	3.5	3.5	5.9	6.2	6.2	8	8.2	8.23	8.4	9.77	10.0	9.91	10.1
Max Mechanical Speed ⑤	Nom	N _{max}	rpm	8000	8000	8000	8000	8000	8000	8000	8000	8000	8000	8000	8000	8000	8000
Peak Torque ①②	Nom	T _p	Nm	1.47	1.49	1.51	2.73	2.76	2.79	4.4	3.84	3.86	3.88	5.51	4.76	4.79	4.82
			lb-in	13.0	13.2	13.4	24.2	24.4	24.7	38.9	34.0	34.2	34.3	48.8	42.1	42.4	42.7
Peak Current	Nom	I _p	A _{RMS}	6.3	12.4	19.5	5.6	10.9	19.3	7.1	8.8	11.1	17.2	7.1	8.8	11.2	15.6
Rated Torque (speed) ①②⑦⑧⑨⑩	75 Vdc	T _{rtd}	Nm	-	0.48	0.46	-	0.85	0.83	-	-	-	1.15	-	-	-	1.39
			lb-in	-	4.2	4.1	-	7.5	7.4	-	-	-	10.2	-	-	-	12.3
Rated Speed		N _{rtd}	rpm	-	2000	4000	-	1000	2500	-	-	-	1500	-	-	-	1000
Rated Power (speed) ①②⑦⑧⑨	75 Vdc	P _{rtd}	kW	-	0.10	0.19	-	0.09	0.22	-	-	-	0.18	-	-	-	0.15
			Hp	-	0.13	0.26	-	0.12	0.29	-	-	-	0.24	-	-	-	0.20
Rated Torque (speed) ①②⑦⑧⑨⑩	120 Vac (160 Vdc)	T _{rtd}	Nm	0.46	0.41	-	0.83	0.81	0.74	1.11	1.12	1.1	1.07	-	1.36	1.34	1.33
			lb-in	4.0	3.7	-	7.3	7.1	6.5	9.8	9.9	9.7	9.5	-	12.0	11.9	11.8
Rated Speed		N _{rtd}	rpm	2500	7000	-	1000	3500	7000	1000	1500	2500	4500	-	1500	2000	3000
Rated Power (speed) ①②⑦⑧⑨	120 Vac (160 Vdc)	P _{rtd}	kW	0.12	0.30	-	0.09	0.30	0.54	0.12	0.18	0.29	0.50	-	0.21	0.28	0.42
			Hp	0.16	0.41	-	0.12	0.40	0.72	0.16	0.24	0.39	0.68	-	0.29	0.38	0.56
Rated Torque (speed) ①②⑦⑧⑨⑩	240 Vac (320 Vdc)	T _{rtd}	Nm	0.39	-	-	0.78	.70	-	1.08	1.03	0.98	0.94	1.32	1.29	1.24	1.12
			lb-in	3.4	-	-	6.9	6.2	-	9.6	9.1	8.7	8.3	11.7	11.4	11.0	9.9
Rated Speed		N _{rtd}	rpm	8000	-	-	3500	8000	-	2500	5000	6500	8000	2000	4000	5500	8000
Rated Power (speed) ①②⑦⑧⑨	240 Vac (320 Vdc)	P _{rtd}	kW	0.32	-	-	0.29	0.59	-	0.28	0.54	0.67	0.79	0.28	0.54	0.71	0.94
			Hp	0.43	-	-	0.38	0.79	-	0.38	0.72	0.89	1.06	0.37	0.72	0.96	1.26
Rated Torque (speed) ①②⑦⑧⑨⑩	400 Vac (560 Vdc)	T _{rtd}	Nm	-	-	-	0.68	-	-	0.99	0.92	-	-	1.25	1.11	-	-
			lb-in	-	-	-	6.0	-	-	8.8	8.1	-	-	11.1	9.8	-	-
Rated Speed		N _{rtd}	rpm	-	-	-	8000	-	-	5500	8000	-	-	4500	8000	-	-
Rated Power (speed) ①②⑦⑧⑨	400 Vac (560 Vdc)	P _{rtd}	kW	-	-	-	0.57	-	-	0.57	0.77	-	-	0.59	0.93	-	-
			Hp	-	-	-	0.76	-	-	0.76	1.03	-	-	0.79	1.25	-	-
Rated Torque (speed) ①②⑦⑧⑨⑩	480 Vac (640 Vdc)	T _{rtd}	Nm	-	-	-	0.68	-	-	0.95	0.92	-	-	1.22	1.11	-	-
			lb-in	-	-	-	6.0	-	-	8.4	8.1	-	-	10.8	9.8	-	-
Rated Speed		N _{rtd}	rpm	-	-	-	8000	-	-	7000	8000	-	-	5500	8000	-	-
Rated Power (speed) ①②⑦⑧⑨	480 Vac (640 Vdc)	P _{rtd}	kW	-	-	-	0.57	-	-	0.7	0.77	-	-	0.94	0.93	-	-
			Hp	-	-	-	0.76	-	-	0.93	1.03	-	-	0.7	1.25	-	-

See following page for notes.

AKM2x Performance Data – Up to 480 Vac (640 Vdc Bus) voltage (Continued)

Parameters	Tol	Symbol	Units	AKM21			AKM22			AKM23				AKM24			
				C	E	G	C	E	G	C	D	E	F	C	D	E	F
Torque Constant ①	±10%	K _t	Nm/A _{rms}	0.30	0.16	0.10	0.61	0.32	0.18	0.8	0.52	0.42	0.27	0.97	0.63	0.50	0.36
			lb-in/A _{rms}	2.7	1.4	0.9	5.4	2.8	1.6	7.1	4.6	3.7	2.4	8.6	5.6	4.4	3.2
Back EMF Constant ②	±10%	K _e	V _{rms} /krpm	19.5	10.2	6.6	39	20.4	11.7	51.8	33.8	27.0	17.6	62.4	40.8	32.5	23.4
Motor Constant	Nom	K _m	N-m/√W	0.0679	0.0706	0.0680	0.111	0.114	0.110	0.142	0.143	0.147	0.144	0.175	0.171	0.175	0.171
			lb-in/√W	0.601	0.625	0.602	0.986	1.01	0.98	1.26	1.27	1.30	1.28	1.55	1.52	1.55	1.52
Resistance (line-line) ⑥	±10%	R _m	ohm	13	3.42	1.44	19.98	5.22	1.77	21.23	8.77	5.44	2.34	20.4	9.02	5.44	2.94
Inductance (line-line)		L	mH	19	5.2	2.18	35.5	9.7	3.19	40.7	17.3	11.1	4.68	43.8	18.7	11.8	6.16
Inertia (includes Resolver feedback) ③	±10%	J _m	kg-cm ²	0.11			0.16			0.22				0.27			
			lb-in-s ²	9.5E-05			1.4E-04			1.9E-04				2.4E-04			
Optional Brake Inertia (additional)	±10%	J _m	kg-cm ²	0.013			0.013			0.013				0.013			
			lb-in-s ²	1.2E-05			1.2E-05			1.2E-05				1.2E-05			
Weight (w/o brake) ⑩		W	kg	0.82			1.1			1.38				1.66			
			lb	1.8			2.4			3.0				3.7			
Static Friction ⑪⑫		T _f	Nm	0.002			0.005			0.007				0.01			
			lb-in	0.02			0.04			0.06				0.09			
Viscous Damping ⑬		K _{dv}	Nm/krpm	0.0046			0.0055			0.0065				0.0074			
			lb-in/krpm	0.04			0.05			0.06				0.07			
Thermal Time Constant		TCT	minutes	8			9			10				11			
Thermal Resistance		R _{thw-a}	°C/W	1.43			1.19			1.10				1.07			
Operating Ambient Temperature Range ⑭ ⑮			°C	-20 to 40			-20 to 40			-20 to 40				-20 to 40			
Pole Pairs				3			3			3				3			
Heat Sink Size				10"x10"x1/4" Aluminum Plate			10"x10"x1/4" Aluminum Plate			10"x10"x1/4" Aluminum Plate				10"x10"x1/4" Aluminum Plate			

Notes:

- ① Motor winding temperature rise, ΔT=100°C, at 40°C ambient.
- ② All data referenced to sinusoidal commutation.
- ③ Add parking brake if applicable for total inertia.
- ④ Motor with standard heat sink.
- ⑤ May be limited at some values of Vbus.
- ⑥ Measured at 25°C.
- ⑦ Brake option reduces continuous torque ratings by:
AKM21 = 0.00 AKM22 = 0.01 Nm AKM23 = 0.02 Nm AKM24 = 0.05 Nm
- ⑧ For non-resolver feedback options: no continuous torque reduction.
- ⑨ Motors with non-resolver feedback and brake option, reduce continuous torque by:
AKM21 = 0.00 AKM22 = 0.02 Nm AKM23 = 0.05 Nm AKM24 = 0.12 Nm
- ⑩ For motors with optional shaft seal, reduce torque shown by 0.047 Nm (0.41 lb-in), and increase T_f by the same amount.
- ⑪ Brake option increases weight by 0.27 kg (0.59 lb).
- ⑫ Motors can be operated up to 480 Vac. For performances curves at voltages, listed or unlisted, please use our online [Performance Curve Generator Tool](#).
- ⑬ Brake option will operate in this range in a non-condensing environment. See page 55 for more information.
- ⑭ "AA" or "AB" BiSS feedback lower limit is -15°C; all other feedbacks meet or exceed this range.
- ⑮ Operation outside of this range may be possible. Please contact Kollmorgen Customer Support with your application requirements.

Additional Notes:

See system data beginning on page 14 for typical torque/speed performance.

Additional windings may exist. Please contact Kollmorgen Customer Support for further information or to request custom winding options for your application requirements.

*Complete AKM series model nomenclature can be found on pages 10-12.

AKM[®] Servo Motor Specifications

AKM2x Frame Dimensional Drawings

AKM 2D/3D CAD models can be found here: [AKM CAD Models](#)

B- connector option

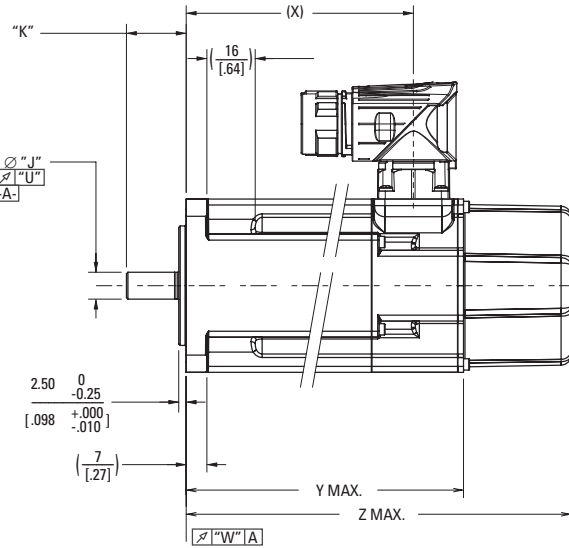
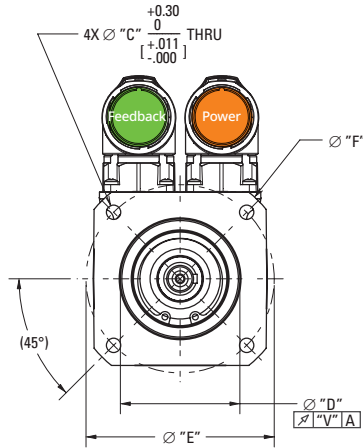

G- connector option

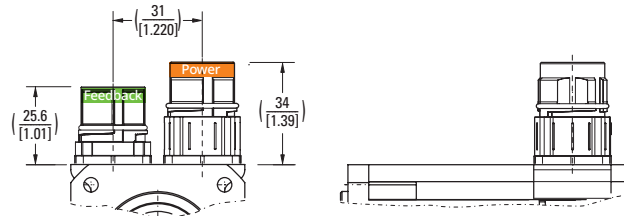
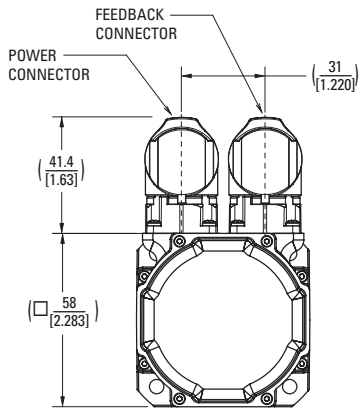

D-, 9- connector options

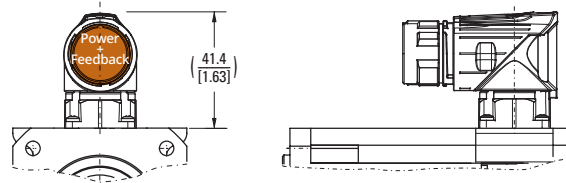

C-, M-, P- connector options

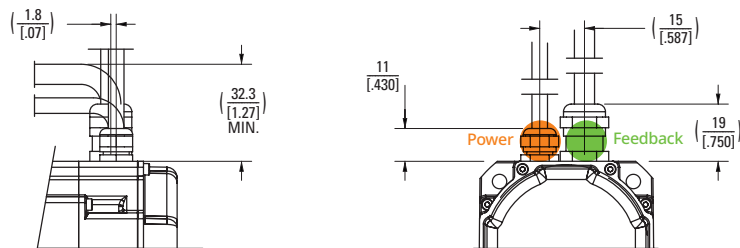

Shaft-keyway dimensions

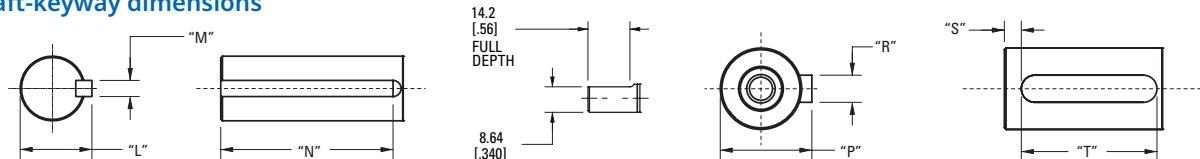

Dimensional data tables for callouts are located on the following page.

AKM2x Mounting Flange-Shaft Dimensional Data

Mounting Flange-Shaft	Hole Diameter "C"	Pilot Diameter "D"	Bolt Circle Dia. "E"	"F"	"H"	Shaft Diameter "J"	Shaft Length "K"	Shaft Dia. w/ Key "L"
AC	4.80 [0.189]	40 [1.5748]	63 [2.480]	74 [2.913]	D M3 DIN 332	9 [0.3543]	20.0 [0.79]	-
AN	4.80 [0.189]	40 [1.5748]	63 [2.480]	74 [2.913]	D M3 DIN 332	9 [0.3543]	20.0 [0.79]	-
BN	5.10 [0.201]	38.10 [1.500]	66.68 [2.625]	-	-	9.525 [0.3750]	31.75 [1.250]	-
CK	5.80 [0.228]	50 [1.9685]	70 [2.756]	-	-	14 [0.5512]	30.0 [1.181]	16 [0.630]
DC	5.80 [0.228]	40 [1.5748]	65 [2.559]	-	D M3 DIN 332	9 [0.3543]	20.0 [0.79]	-
DN	5.80 [0.228]	40 [1.5748]	65 [2.559]	-	D M3 DIN 332	9 [0.3543]	20.0 [0.79]	-
EN & EF	5.10 [0.201]	38.10 [1.500]	66.68 [2.625]	-	-	9.525 [0.3750]	20.57 [0.810]	-

Mounting Flange-Shaft	Key Width "M"	Key Length "N"	Shaft Dia. w/ Key "P"	Key Width "R"	"S"	Key Length "T"	"U"	"V"	"W"
AC	-	-	10.2 [0.402]	3 [0.1181]	300 [0.118]	12 [0.472]	0.030 [0.0011]	0.060 [0.0023]	0.060 [0.0023]
AN	-	-	-	-	-	-	0.030 [0.0011]	0.060 [0.0023]	0.060 [0.0023]
BN	-	-	-	-	-	-	0.051 [0.0020]	0.10 [0.004]	0.10 [0.004]
CK	5 [0.197]	20 [0.787]	-	-	-	-	0.035 [0.0013]	0.080 [0.0031]	0.080 [0.0031]
DC	-	-	10.2 [0.402]	3 [0.1181]	300 [0.118]	12 [0.472]	0.030 [0.0011]	0.060 [0.0023]	0.060 [0.0023]
DN	-	-	-	-	-	-	0.030 [0.0011]	0.060 [0.0023]	0.060 [0.0023]
EN & EF	-	-	-	-	-	-	0.051 [0.0020]	0.10 [0.004]	0.10 [0.004]

AKM2x Motor Length Dimensional Data

Connector	No Brake (N)					
	X		Y MAX		Z MAX	
	C-, M-, P-	B-, D-, G-, 9-	C-, M-	B-, D-, G-, 9-	C-, M-, P-	B-, D-, G-, 9-
Feedback Option	R, C-, 1-, 2-, Ex, Ax, Dx, Lx	R, C-, CA-, 1-, 2-, Ex, Ax, Dx, Lx, Gx	R-	R, C-, CA-, 1-, 2-, Ex, Ax, Dx, Lx	C-, 1-, 2-, Ex, Ax, Dx, Lx	Gx
AKM21	74.6 [2.94]	76.1 [3]	86.2 [3.39]	95.4 [3.76]	95.4 [3.76]	113.4 [4.46]
AKM22	93.6 [3.69]	95.1 [3.74]	105.2 [4.14]	114.4 [4.5]	114.4 [4.5]	132.4 [5.21]
AKM23	112.6 [4.43]	114.1 [4.49]	124.2 [4.89]	133.4 [5.25]	133.4 [5.25]	151.4 [5.96]
AKM24	131.6 [5.18]	133.1 [5.24]	143.2 [5.64]	152.4 [6]	152.4 [6]	170.4 [6.71]

Connector	Brake (2)				
	X		Z MAX		
	C-, M-, P-	B-, D-, G-, 9-	C-, M-, P-	B-, D-, G-, 9-	B-, D-, G-, 9-
Feedback Option	R, C-, 1-, 2-, Ex, Ax, Dx, Lx	R, C-, CA-, 1-, 2-, Ex, Ax, Dx, Lx, Gx	R, C-, 1-, 2-, Ex, Ax, Dx, Lx	R, C-, CA-, 1-, 2-, Ex, Ax, Dx, Lx	Gx
AKM21	74.6 [2.94]	76.1 [3]	129.5 [5.1]		147.1 [5.79]
AKM22	93.6 [3.69]	95.1 [3.74]	148.5 [5.85]		166.1 [6.54]
AKM23	112.6 [4.43]	114.1 [4.49]	167.5 [6.59]		185.1 [7.29]
AKM24	131.6 [5.18]	133.1 [5.24]	186.5 [7.34]		204.1 [8.04]

Note 1: Dimensions are in mm [inches].

Note 2: Detailed Connector and Feedback option information can be found on pages 11-12.

Note 3: Product designed in metric. English conversions provided for reference only.

*Complete AKM series model nomenclature can be found on pages 10-12.

AKM[®] Servo Motor Specifications

AKM3x Performance Data – Up to 480 Vac (640 Vdc Bus) voltage

Parameters	Tol	Symbol	Units	AKM31			AKM32				AKM33		
				C	E	H	C	D	E	H	C	E	H
Max Rated Voltage ⑥	Max	-	Vac	480	240	120	480	480	480	240	480	480	240
			Vdc	640	320	160	640	640	640	320	640	640	320
Continuous Torque (Stall) for ΔT winding = 100°C ①②⑦⑧⑨	Nom	T _{CS}	Nm	1.15	1.20	1.23	2.00	2.04	2.04	2.10	2.71	2.79	2.88
			lb-in	10.2	10.6	10.8	17.7	18.1	18.1	18.6	24.0	24.7	25.5
Continuous Current (Stall) for ΔT winding = 100°C ①②⑦⑧⑨	Nom	I _{CS}	A _{RMS}	1.37	2.99	5.85	1.44	2.23	2.82	5.50	1.47	2.58	5.62
Continuous Torque (Stall) for ΔT winding = 60°C ②	Nom	T _{CS}	Nm	0.92	0.96	0.98	1.60	1.63	1.63	1.68	2.17	2.23	2.30
			lb-in	8.1	8.5	8.7	14.2	14.4	14.4	14.9	19.2	19.7	20.4
Max Mechanical Speed ⑤	Nom	N _{max}	rpm	8000	8000	8000	8000	8000	8000	8000	8000	8000	8000
Peak Torque ①②	Nom	T _p	Nm	3.88	4.00	4.06	6.92	7.10	7.11	7.26	9.76	9.96	10.22
			lb-in	34.3	35.4	35.9	61.2	62.8	62.9	64.3	86.4	88.1	90.5
Peak Current	Nom	I _p	A _{RMS}	5.5	12.0	23.4	5.7	8.92	11.3	22.0	5.9	10.3	22.5
Rated Torque (speed) ①②⑦⑧⑨⑩		T _{rtd}	Nm	-	1.19	1.20	-	-	-	2.06	-	-	2.82
			lb-in	-	10.5	10.6	-	-	-	18.2	-	-	24.6
Rated Speed		N _{rtd}	rpm	-	750	2000	-	-	-	1200	-	-	800
			kW	-	0.09	0.25	-	-	-	0.26	-	-	0.24
Rated Power (speed) ①②⑦⑧⑨		P _{rtd}	Hp	-	0.13	0.34	-	-	-	0.35	-	-	0.32
			Nm	-	1.17	0.97	-	2.00	2.01	1.96	-	-	2.66
Rated Torque (speed) ①②⑦⑧⑨⑩		T _{rtd}	lb-in	-	10.3	8.6	-	17.7	17.7	17.4	-	-	23.5
			rpm	-	2500	6000	-	1000	1000	3000	-	-	2500
Rated Power (speed) ①②⑦⑧⑨		P _{rtd}	kW	-	0.31	0.61	-	0.21	0.21	0.62	-	-	0.70
			Hp	-	0.41	0.82	-	0.28	0.28	0.83	-	-	0.93
Rated Torque (speed) ①②⑦⑧⑨⑩		T _{rtd}	Nm	1.12	0.95	-	1.95	1.93	1.91	1.45	2.64	2.62	2.27
			lb-in	9.9	8.4	-	17.3	17.1	16.9	12.8	23.4	23.2	20.1
Rated Speed		N _{rtd}	rpm	2500	6000	-	1500	2500	3000	7000	1000	2000	5500
Rated Power (speed) ①②⑦⑧⑨		P _{rtd}	kW	0.29	0.60	-	0.31	0.51	0.6	1.06	0.28	0.55	1.31
			Hp	0.39	0.80	-	0.41	0.68	0.80	1.42	0.37	0.74	1.75
Rated Torque (speed) ①②⑦⑧⑨⑩		T _{rtd}	Nm	1.00	-	-	1.86	1.65	1.50	-	2.54	2.34	-
			lb-in	8.9	-	-	16.5	14.6	13.3	-	22.5	20.7	-
Rated Speed		N _{rtd}	rpm	5000	-	-	3000	5500	6500	-	2000	4500	-
Rated Power (speed) ①②⑦⑧⑨		P _{rtd}	kW	0.52	-	-	0.58	0.95	1.02	-	0.53	1.10	-
			Hp	0.70	-	-	0.78	1.27	1.37	-	0.71	1.48	-
Rated Torque (speed) ①②⑦⑧⑨⑩		T _{rtd}	Nm	0.91	-	-	1.83	1.58	1.22	-	2.50	2.27	-
			lb-in	8.1	-	-	16.2	14.0	10.8	-	22.1	20.1	-
Rated Speed		N _{rtd}	rpm	6000	-	-	3500	6000	8000	-	2500	5000	-
Rated Power (speed) ①②⑦⑧⑨		P _{rtd}	kW	0.57	-	-	0.67	0.99	1.02	-	0.65	1.19	-
			Hp	0.77	-	-	0.90	1.33	1.37	-	0.88	1.59	-

See following page for notes.

AKM3x Performance Data – Up to 480 Vac (640 Vdc Bus) voltage (Continued)

Parameters	Tol	Symbol	Units	AKM31			AKM32				AKM33		
				C	E	H	C	D	E	H	C	E	H
Torque Constant ①	±10%	K _t	Nm/A _{rms}	0.85	0.41	0.21	1.40	0.91	0.73	0.39	1.86	1.10	0.52
			lb-in/A _{rms}	7.5	3.6	1.9	12.4	8.05	6.5	3.5	16.5	9.7	4.6
Back EMF Constant ⑥	±10%	K _e	V _{rms} /krpm	54.5	26.1	13.7	89.8	59.0	47.1	24.8	120	70.6	33.4
Motor Constant	Nom	K _m	N-m/√W	0.150	0.154	0.151	0.235	0.232	0.237	0.245	0.295	0.299	0.303
			lb-in/√W	1.33	1.36	1.34	2.08	2.05	2.10	2.17	2.61	2.65	2.68
Resistance (line-line) ⑥	±10%	R _m	ohm	21.4	4.74	1.29	23.76	10.30	6.32	1.69	26.59	9.01	1.96
Inductance (line-line)		L	mH	37.5	8.6	2.4	46.5	20.10	12.8	3.55	53.6	18.5	4.1
Inertia (includes Resolver feedback) ③	±10%	J _m	kg-cm ²	0.33			0.59				0.85		
			lb-in-s ²	2.9E-04			5.2E-04				7.5E-04		
Optional Brake Inertia (additional)	±10%	J _m	kg-cm ²	0.014			0.014				0.014		
			lb-in-s ²	1.2E-05			1.2E-05				1.2E-05		
Weight (w/o brake) ⑩		W	kg	1.55			2.23				2.9		
			lb	3.4			4.9				6.4		
Static Friction ①⑩		T _f	Nm	0.014			0.02				0.026		
			lb-in	0.12			0.18				0.23		
Viscous Damping ①		K _{dv}	Nm/krpm	0.002			0.003				0.004		
			lb-in/krpm	0.02			0.03				0.04		
Thermal Time Constant		TCT	minutes	14			17				20		
Thermal Resistance		R _{thw-a}	°C/W	1.11			0.92				0.78		
Operating Ambient Temperature Range ⑬ ⑭ ⑮			°C	-20 to 40			-20 to 40				-20 to 40		
Pole Pairs				4			4				4		
Heat Sink Size				10"x10"x1/4" Aluminum Plate			10"x10"x1/4" Aluminum Plate				10"x10"x1/4" Aluminum Plate		

Notes:

- ① Motor winding temperature rise, ΔT=100°C, at 40°C ambient.
- ② All data referenced to sinusoidal commutation.
- ③ Add parking brake if applicable for total inertia.
- ④ Motor with standard heat sink.
- ⑤ May be limited at some values of V_{bus}.
- ⑥ Measured at 25°C.
- ⑦ Brake option reduces continuous torque ratings by:
AKM31 = 0.0 Nm AKM32 = 0.05 Nm AKM33 = 0.1 Nm
- ⑧ For non-resolver feedback options: no continuous torque reduction.
- ⑨ Motors with non-resolver feedback and brake option, reduce continuous torque by:
AKM31 = 0.0 Nm AKM32 = 0.1 Nm AKM33 = 0.2 Nm
- ⑩ For motors with optional shaft seal, reduce torque shown by 0.047 Nm (0.41 lb-in), and increase T_f by the same amount.
- ⑪ Brake option increases weight by 0.36 kg (0.79 lb).
- ⑫ Motors can be operated up to 480 Vac. For performances curves at voltages, listed or unlisted, please use our online [Performance Curve Generator Tool](#).
- ⑬ Brake option will operate in this range in a non-condensing environment. See page 55 for more information.
- ⑭ "AA" or "AB" BiSS feedback lower limit is -15°C; all other feedbacks meet or exceed this range.
- ⑮ Operation outside of this range may be possible. Please contact Kollmorgen Customer Support with your application requirements.

Additional Notes:

See system data beginning on page 14 for typical torque/speed performance.

Additional windings may exist. Please contact Kollmorgen Customer Support for further information or to request custom winding options for your application requirements.

*Complete AKM series model nomenclature can be found on pages 10-12.

AKM[®] Servo Motor Specifications

AKM3x Frame Dimensional Drawings

AKM 2D/3D CAD models can be found here: [AKM CAD Models](#)

C- connector option

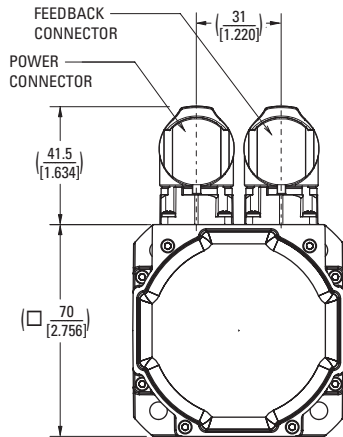
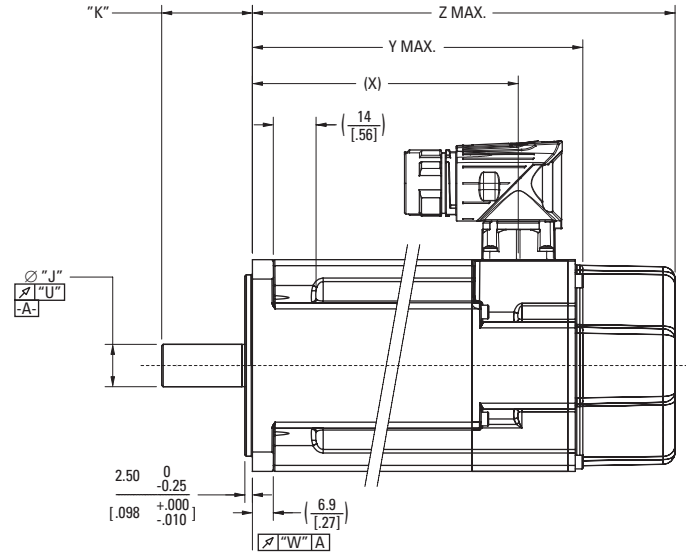
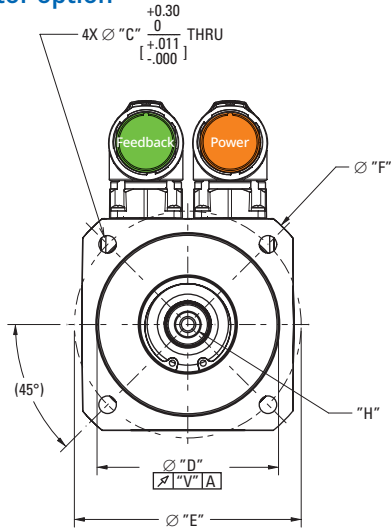

G- connector option

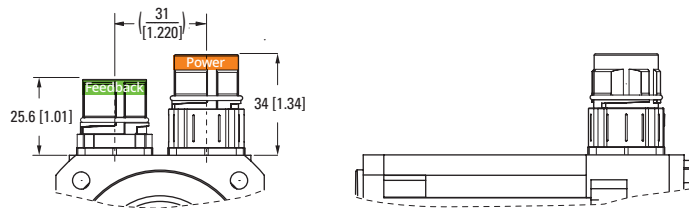

D-, 9- connector option

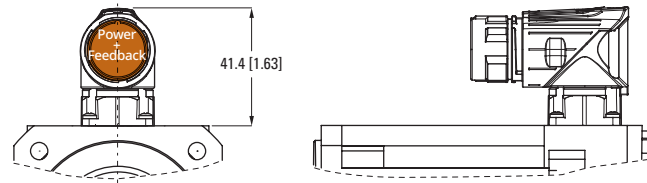

M-, P- connector options

- AKM31 (94.6 [3.72])
- AKM32 (125.6 [4.94])
- AKM33 (156.6 [6.17])

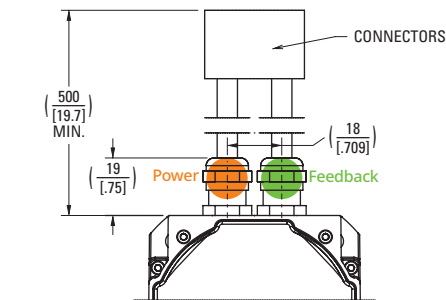
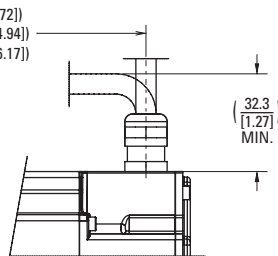

Shaft-keyway dimensions

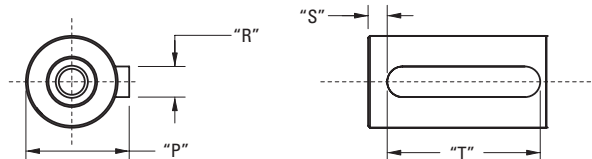

Dimensional data tables for callouts are located on the following page.

AKM3x Mounting Flange-Shaft Dimensional Data

Mounting Flange-Shaft	Hole Diameter "C"	Pilot Diameter "D"	Bolt Circle Dia. "E"	"F"	"H"	Shaft Diameter "J"	Shaft Length "K"	Shaft Dia. w/ Key "P"
AC	5.80 [0.228]	60 [2.3622]	75 [2.953]	90 [3.543]	D M5 DIN 332	14 [0.5512]	30.0 [1.181]	16 [0.630]
AN	5.80 [0.228]	60 [2.3622]	75 [2.953]	90 [3.543]	D M5 DIN 332	14 [0.5512]	30.0 [1.181]	-
CC	5.80 [0.228]	60 [2.3622]	85 [3.346]	-	D M5 DIN 332	14 [0.5512]	30.0 [1.181]	16 [0.630]
CN	5.80 [0.228]	60 [2.3622]	85 [3.346]	-	D M5 DIN 332	14 [0.5512]	30.0 [1.181]	-
GC	5.80 [0.228]	60 [2.3622]	75 [2.953]	90 [3.543]	D M5 DIN 332	11[0.4331]	23 [0.906]	12.5 [0.492]
GN	5.80 [0.228]	60 [2.3622]	75 [2.953]	90 [3.543]	D M5 DIN 332	11 [0.4331]	23 [0.906]	-

Mounting Flange-Shaft	Key Width "R"	"S"	Key Length "T"	"U"	"V"	"W"
AC	5 [0.197]	5.00 [1.97]	20 [0.787]	0.035 [0.0013]	0.080 [0.0031]	0.080 [0.0031]
AN	-	-	-	0.035 [0.0013]	0.080 [0.0031]	0.080 [0.0031]
CC	5 [0.197]	5.00 [1.97]	20 [0.787]	0.035 [0.0013]	0.080 [0.0031]	0.080 [0.0031]
CN	-	-	-	0.035 [0.0013]	0.080 [0.0031]	0.080 [0.0031]
GC	4 [0.157]	3.5 [0.138]	16 [0.630]	0.035 [0.0013]	0.080 [0.0031]	0.080 [0.0031]
GN	-	-	-	0.035 [0.0013]	0.080 [0.0031]	0.080 [0.0031]

AKM3x Motor Length Dimensional Data

	No Brake (N)		
	X*	Y MAX	Z MAX
Connector	C-, D-, 9-, G-, M-, P-	C-, D-, 9-, G-, M-, P-	C-, 9-, G-
Feedback Option	R-, C-, CA, 1-, 2-, Ex, Ax, Dx, Lx, Gx	R-, C-, CA-, 1-, 2-, Ex, Ax, Dx, Lx	Gx
AKM31	87.9 [3.46]	109.8 [4.32]	125.3 [4.93]
AKM32	118.9 [4.68]	140.8 [5.54]	156.3 [6.15]
AKM33	149.9 [5.9]	171.8 [6.76]	187.3 [7.37]

	Brake (2)		
	X*	Z MAX	
Connector	C-, D-, 9-, G-, M-, P-	C-, D-, 9-, G-, M-, P-	C-, 9-, G-
Feedback Option	R-, C-, CA, 1-, 2-, Ex, Ax, Dx, Lx, Gx	R-, C-, CA-, 1-, 2-, Ex, Ax, Dx, Lx	Gx
AKM31	87.9 [3.46]	141.3 [5.56]	159.3 [6.27]
AKM32	118.9 [4.68]	172.3 [6.78]	190.3 [7.49]
AKM33	149.9 [5.9]	203.3 [8]	221.3 [8.71]

*For 0.5m shielded cable option (M or P), add 6.7 mm to "X"

Note 1: Dimensions are in mm [inches].

Note 2: Detailed Connector and Feedback option information can be found on pages 11-12.

Note 3: Product designed in metric. English conversions provided for reference only.

*Complete AKM series model nomenclature can be found on pages 10-12.

AKM[®] Servo Motor Specifications

AKM4x Performance Data – Up to 480 Vac (640 Vdc Bus) voltage

Parameters	Tol	Sym	Units	AKM41			AKM42				
				C	E	H	C	E	G	H	J
Max Rated Voltage ⑩	Max	-	Vac	480	480	240	480	480	480	120	240
			Vdc	640	640	320	640	640	640	160	320
Continuous Torque (Stall) for ΔT winding = 100°C ①②⑦⑧⑨	Nom	T _{CS}	Nm	1.95	2.02	2.06	3.35	3.42	3.53	3.54	3.56
			lb-in	17.3	17.9	18.2	29.6	30.3	31.2	31.3	31.5
Continuous Current (Stall) for ΔT winding = 100°C ①②⑦⑧⑨	Nom	I _{CS}	A _{rms}	1.46	2.85	5.60	1.40	2.74	4.80	6	8.40
Continuous Torque (Stall) for ΔT winding = 60°C ②	Nom	T _{CS}	Nm	1.56	1.62	1.65	2.68	2.74	2.82	2.83	2.85
			lb-in	13.8	14.3	14.6	23.7	24.2	25.0	25	25.2
Max Mechanical Speed ⑤	Nom	N _{max}	rpm	6000	6000	6000	6000	6000	6000	6000	6000
Peak Torque ①②	Nom	T _p	Nm	6.12	6.28	6.36	11.1	11.3	11.5	13.34	11.6
			lb-in	54.2	55.6	56.3	98.2	99.7	102	118.1	103
Peak Current	Nom	I _p	A _{rms}	5.8	11.4	22.4	5.60	11.0	19.2	30	33.7
75 Vdc Rated Torque (speed) ①②⑦⑧⑨⑩		T _{rtd}	Nm	-	-	1.99	-	-	-	-	-
			lb-in	-	-	17.6	-	-	-	-	-
Rated Speed		N _{rtd}	rpm	-	-	1000	-	-	-	-	
Rated Power (speed) ①②⑦⑧⑨		P _{rtd}	kW	-	-	0.21	-	-	-	-	-
			Hp	-	-	0.28	-	-	-	-	-
120 Vac (160 Vdc) Rated Torque (speed) ①②⑦⑧⑨⑩		T _{rtd}	Nm	-	1.94	1.86	-	-	-	3.2	3.03
			lb-in	-	17.2	16.5	-	-	-	28.3	26.8
Rated Speed		N _{rtd}	rpm	-	1200	3000	-	-	-	2000	3000
Rated Power (speed) ①②⑦⑧⑨		P _{rtd}	kW	-	0.24	0.58	-	-	-	0.67	0.95
			Hp	-	0.33	0.78	-	-	-	0.9	1.28
240 Vac (320 Vdc) Rated Torque (speed) ①②⑦⑧⑨⑩		T _{rtd}	Nm	1.88	1.82	1.62	-	3.12	2.90	-	2.38
			lb-in	16.6	16.1	14.3	-	27.6	25.7	-	21.1
Rated Speed		N _{rtd}	rpm	1200	3000	6000	-	1800	3500	-	6000
Rated Power (speed) ①②⑦⑧⑨		P _{rtd}	kW	0.24	0.57	1.02	-	0.59	1.06	-	1.50
			Hp	0.32	0.77	1.36	-	0.79	1.42	-	2.00
400 Vac (560 Vdc) Rated Torque (speed) ①②⑦⑧⑨⑩		T _{rtd}	Nm	1.77	1.58	-	3.10	2.81	2.35	-	-
			lb-in	15.7	14.0	-	27.4	24.9	20.8	-	-
Rated Speed		N _{rtd}	rpm	3000	6000	-	1500	3500	6000	-	-
Rated Power (speed) ①②⑦⑧⑨		P _{rtd}	kW	0.56	0.99	-	0.49	1.03	1.48	-	-
			Hp	0.75	1.33	-	0.65	1.38	1.98	-	-
480 Vac (640 Vdc) Rated Torque (speed) ①②⑦⑧⑨⑩		T _{rtd}	Nm	1.74	1.58	-	3.02	2.72	2.35	-	-
			lb-in	15.4	14.0	-	26.7	24.1	20.8	-	-
Rated Speed		N _{rtd}	rpm	3500	6000	-	2000	4000	6000	-	-
Rated Power (speed) ①②⑦⑧⑨		P _{rtd}	kW	0.64	0.99	-	0.63	1.14	1.48	-	-
			Hp	0.85	1.33	-	0.85	1.53	1.98	-	-

See following page for notes.

AKM4x Performance Data – Up to 480 Vac (640 Vdc Bus) voltage (Continued)

Parameters	Tol	Sym	Units	AKM41			AKM42				
				C	E	H	C	E	G	H	J
Torque Constant ①	±10%	K _t	Nm/A _{rms}	1.34	0.71	0.37	2.40	1.26	0.74	0.59	0.43
			lb-in/A _{rms}	11.9	6.3	3.3	21.2	11.2	6.5	5.2	3.8
Back EMF Constant ②	±10%	K _e	V _{rms} /krpm	86.3	45.6	23.7	154	80.9	47.5	38.3	27.5
Motor Constant	Nom	K _m	N-m/√W	0.237	0.236	0.242	0.374	0.369	0.381	0.375	0.393
			lb-in/√W	2.10	2.09	2.14	3.31	3.26	3.37	3.31	3.47
Resistance (line-line) ③	±10%	R _m	ohm	21.3	6.02	1.56	27.5	7.78	2.51	1.65	0.8
Inductance (line-line)		L	mH	66.1	18.4	5.0	97.4	26.8	9.2	6	3.1
Inertia (includes Resolver feedback) ④	±10%	J _m	kg-cm ²	0.81			1.5				
			lb-in-s ²	7.2E-04			1.3E-03				
Optional Brake Inertia (additional)	±10%	J _m	kg-cm ²	0.058			0.058				
			lb-in-s ²	5.1E-05			5.1E-05				
Weight (w/o brake) ⑤		W	kg	2.44			3.39				
			lb	5.4			7.5				
Static Friction ⑥⑦		T _f	Nm	0.014			0.026				
			lb-in	0.12			0.23				
Viscous Damping ⑧		K _{dv}	Nm/krpm	0.009			0.013				
			lb-in/krpm	0.08			0.12				
Thermal Time Constant		TCT	minutes	13			17				
Thermal Resistance		R _{thw-a}	°C/W	0.97			0.80				
Operating Ambient Temperature Range ⑨ ⑩ ⑪			°C	-20 to 40			-20 to 40				
Pole Pairs				5			5				
Heat Sink Size				10"x10"x1/4" Aluminum Plate			10"x10"x1/4" Aluminum Plate				

Notes:

- ① Motor winding temperature rise, ΔT=100°C, at 40°C ambient.
- ② All data referenced to sinusoidal commutation.
- ③ Add parking brake if applicable for total inertia.
- ④ Motor with standard heat sink.
- ⑤ May be limited at some values of Vbus.
- ⑥ Measured at 25°C.
- ⑦ Brake motor option reduces continuous torque ratings by 0.12 Nm.
- ⑧ Non-Resolver feedback options reduces continuous ratings by:
AKM41 = 0.1 Nm AKM42 = 0.1 Nm AKM43 = 0.2 Nm AKM44 = 0.3 Nm
- ⑨ Motors with non-resolver feedback and brake option, reduce continuous torque by:
AKM41 = 0.22 Nm AKM42 = 0.36 Nm AKM43 = 0.55 Nm AKM44 = 0.76 Nm
- ⑩ For motors with optional shaft seal, reduce torque shown by 0.071 Nm (0.63 lb-in), and increase T_f by the same amount.
- ⑪ Brake option increases weight by 0.69 kg (1.52 lb).
- ⑫ Motors can be operated up to 480 Vac. For performances curves at voltages, listed or unlisted, please use our online [Performance Curve Generator Tool](#).
- ⑬ Brake option will operate in this range in a non-condensing environment. See page 55 for more information.
- ⑭ "AA" or "AB" BiSS feedback lower limit is -15°C; all other feedbacks meet or exceed this range.
- ⑮ Operation outside of this range may be possible. Please contact Kollmorgen Customer Support with your application requirements.

Additional Notes:

See system data beginning on page 14 for typical torque/speed performance.

Additional windings may exist. Please contact Kollmorgen Customer Support for further information or to request custom winding options for your application requirements.

*Complete AKM series model nomenclature can be found on pages 10-12.

AKM[®] Servo Motor Specifications

AKM4x Performance Data – Up to 480 Vac (640 Vdc Bus) voltage

Parameters	Tol	Sym	Units	AKM43					AKM44				
				E	G	H	K	L	E	G	H	J	K
Max Rated Voltage ⑩	Max	-	Vac	480	480	480	240	240	480	480	480	480	240
			Vdc	640	640	640	320	320	640	640	640	640	320
Continuous Torque (Stall) for ΔT winding = 100°C ①②⑦⑧⑨	Nom	T _{cs}	Nm	4.70	4.8	4.82	4.9	4.73	5.76	5.88	5.89	6.00	5.88
			lb-in	41.6	42.5	42.7	43.4	41.9	51.0	52	52.1	53.1	52
Continuous Current (Stall) for ΔT winding = 100°C ①②⑦⑧⑨	Nom	I _{cs}	A _{rms}	2.76	4.87	5.4	9.6	11.2	2.9	10.1	5.6	8.8	10.1
Continuous Torque (Stall) for ΔT winding = 60°C ②	Nom	T _{cs}	Nm	3.76	3.84	3.86	3.92	3.78	4.61	4.7	4.71	4.80	4.7
			lb-in	33.3	34	34.2	34.7	33.5	40.8	41.6	41.7	42.5	41.6
Max Mechanical Speed ⑤	Nom	N _{max}	rpm	6000	6000	6000	6000	6000	6000	6000	6000	6000	6000
Peak Torque ①②	Nom	T _p	Nm	15.9	18.9	16.1	19	16.0	19.9	23.7	20.2	20.4	23.7
			lb-in	141	166	142	168	142	176	210	179	181	210
Peak Current	Nom	I _p	A _{rms}	11.0	24.4	21.6	48	44.6	11.4	50.5	22.4	35.2	50.5
75 Vdc Rated Torque (speed) ①②⑦⑧⑨⑩		T _{rtd}	Nm	-	-	-	-	-	-	-	-	-	-
			lb-in	-	-	-	-	-	-	-	-	-	-
Rated Speed		N _{rtd}	rpm	-	-	-	-	-	-	-	-	-	-
Rated Power (speed) ①②⑦⑧⑨		P _{rtd}	kW	-	-	-	-	-	-	-	-	-	-
			Hp	-	-	-	-	-	-	-	-	-	-
120 Vac (160 Vdc) Rated Torque (speed) ①②⑦⑧⑨⑩		T _{rtd}	Nm	-	-	4.46	4.08	3.78	-	-	5.44	-	4.9
			lb-in	-	-	39.4	36.1	33.5	-	-	48.2	-	43.4
Rated Speed		N _{rtd}	rpm	-	-	1200	2500	3000	-	-	1000	-	2000
Rated Power (speed) ①②⑦⑧⑨		P _{rtd}	kW	-	-	0.56	1.43	1.19	-	-	0.57	-	1.38
			Hp	-	-	0.75	1.07	1.59	-	-	0.76	-	1.03
240 Vac (320 Vdc) Rated Torque (speed) ①②⑦⑧⑨⑩		T _{rtd}	Nm	4.24	4	3.86	2.62	2.53	5.22	4.9	4.66	3.84	3.18
			lb-in	37.5	35.4	34.2	23.2	22.4	46.2	43.4	41.2	34.0	28.1
Rated Speed		N _{rtd}	rpm	1500	2500	3000	6000	6000	1200	2000	2500	4000	5000
Rated Power (speed) ①②⑦⑧⑨		P _{rtd}	kW	0.67	1.05	1.21	1.65	1.59	0.66	1.38	1.22	1.61	1.67
			Hp	0.89	1.4	1.63	2.21	2.13	0.88	1.03	1.64	2.16	2.23
400 Vac (560 Vdc) Rated Torque (speed) ①②⑦⑧⑨⑩		T _{rtd}	Nm	3.92	3.01	2.81	-	-	4.80	3.18	3.48	2.75	-
			lb-in	34.7	26.6	24.9	-	-	42.5	28.1	30.8	24.3	-
Rated Speed		N _{rtd}	rpm	2500	5000	5500	-	-	2000	5000	4500	6000	-
Rated Power (speed) ①②⑦⑧⑨		P _{rtd}	kW	1.03	1.58	1.62	-	-	1.01	1.67	1.64	1.73	-
			Hp	1.38	2.11	2.17	-	-	1.35	2.23	2.20	2.32	-
480 Vac (640 Vdc) Rated Torque (speed) ①②⑦⑧⑨⑩		T _{rtd}	Nm	3.76	2.57	2.58	-	-	4.56	4.56	2.93	2.75	-
			lb-in	33.3	22.7	22.8	-	-	40.4	40.4	26.0	24.3	-
Rated Speed		N _{rtd}	rpm	3000	6000	6000	-	-	2500	2500	5500	6000	-
Rated Power (speed) ①②⑦⑧⑨		P _{rtd}	kW	1.18	1.61	1.62	-	-	1.19	1.19	1.69	1.73	-
			Hp	1.58	2.16	2.17	-	-	1.60	1.6	2.27	2.32	-

See following page for notes.

AKM4x Performance Data – Up to 480 Vac (640 Vdc Bus) voltage (Continued)

Parameters	Tol	Sym	Units	AKM43					AKM44				
				E	G	H	K	L	E	G	H	J	K
Torque Constant ①	±10%	K _t	Nm/A _{rms}	1.72	0.99	0.89	0.52	0.43	2.04	2.04	1.06	0.69	0.59
			lb-in/A _{rms}	15.2	8.8	7.9	4.6	3.8	18.1	18.1	9.4	6.1	5.2
Back EMF Constant ⑥	±10%	K _e	V _{rms} /krpm	111	63.9	57.4	33.2	27.5	132	131.6	68.0	44.2	37.8
Motor Constant	Nom	K _m	N-m/√W	0.479	0.482	0.501	0.494	0.465	0.567	0.567	0.580	0.581	0.288
			lb-in/√W	4.24	4.29	4.44	4.37	4.12	5.01	5.03	5.13	5.14	2.54
Resistance (line-line) ⑥	±10%	R _m	ohm	8.61	2.81	2.1	0.74	0.57	8.64	8.64	2.23	0.94	2.8
Inductance (line-line)		L	mH	32.6	10.8	8.8	2.9	2.0	33.9	33.9	9.1	3.8	0.68
Inertia (includes Resolver feedback) ③	±10%	J _m	kg-cm ²	2.1					2.7				
			lb-in-s ²	1.8E-03					2.4E-03				
Optional Brake Inertia (additional)	±10%	J _m	kg-cm ²	0.058					0.058				
			lb-in-s ²	5.1E-05					5.1E-05				
Weight (w/o brake) ⑩		W	kg	4.35					5.3				
			lb	9.6					11.7				
Static Friction ⑩⑩		T _f	Nm	0.038					0.05				
			lb-in	0.34					0.44				
Viscous Damping ①		K _{dv}	Nm/krpm	0.017					0.021				
			lb-in/krpm	0.15					0.19				
Thermal Time Constant		TCT	minutes	20					24				
Thermal Resistance		R _{thw-a}	°C/W	0.70					0.65				
Operating Ambient Temperature Range ⑩ ⑩ ⑩			°C	-20 to 40					-20 to 40				
Pole Pairs				5					5				
Heat Sink Size				10"x10"x1/4" Aluminum Plate					10"x10"x1/4" Aluminum Plate				

Notes:

- ① Motor winding temperature rise, ΔT=100°C, at 40°C ambient.
- ② All data referenced to sinusoidal commutation.
- ③ Add parking brake if applicable for total inertia.
- ④ Motor with standard heat sink.
- ⑤ May be limited at some values of V_{bus}.
- ⑥ Measured at 25°C.
- ⑦ Brake option reduces continuous torque ratings by 0.12 Nm.
- ⑧ Non-Resolver feedback options reduces continuous ratings by:
AKM41 = 0.1 Nm AKM42 = 0.1 Nm AKM43 = 0.2 Nm AKM44 = 0.3 Nm
- ⑨ Motors with non-resolver feedback and brake option, reduce continuous torque by:
AKM41 = 0.22 Nm AKM42 = 0.36 Nm AKM43 = 0.55 Nm AKM44 = 0.76 Nm
- ⑩ For motors with optional shaft seal, reduce torque shown by 0.071 Nm (0.63 lb-in), and increase T_f by the same amount.
- ⑪ Brake option increases weight by 0.69 kg (1.52 lb).
- ⑫ Motors can be operated up to 480 Vac. For performances curves at voltages, listed or unlisted, please use our online [Performance Curve Generator Tool](#).
- ⑬ Brake option will operate in this range in a non-condensing environment. See page 55 for more information.
- ⑭ "AA" or "AB" BiSS feedback lower limit is -15°C; all other feedbacks meet or exceed this range.
- ⑮ Operation outside of this range may be possible. Please contact Kollmorgen Customer Support with your application requirements.

Additional Notes:

See system data beginning on page 14 for typical torque/speed performance.

Additional windings may exist. Please contact Kollmorgen Customer Support for further information or to request custom winding options for your application requirements.

*Complete AKM series model nomenclature can be found on pages 10-12.

AKM[®] Servo Motor Specifications

AKM4x Frame Dimensional Drawings

AKM 2D/3D CAD models can be found here: [AKM CAD Models](#)

C- connector option

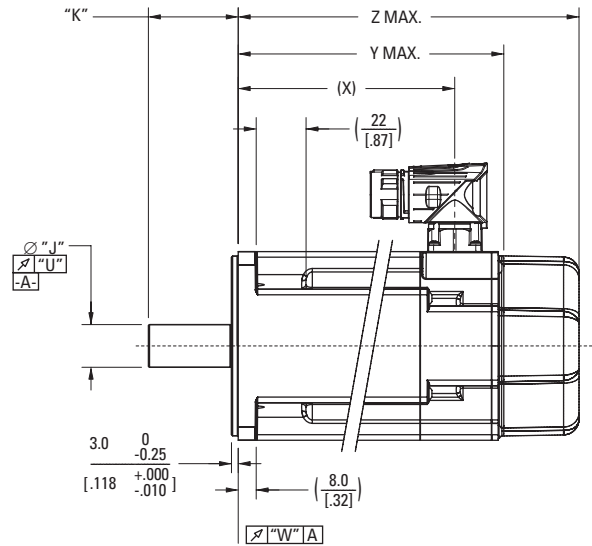
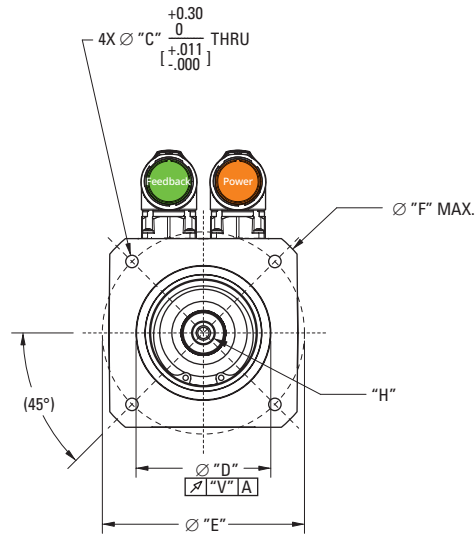

G- connector option

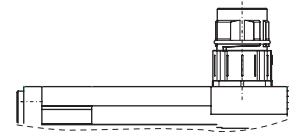
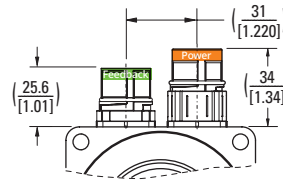
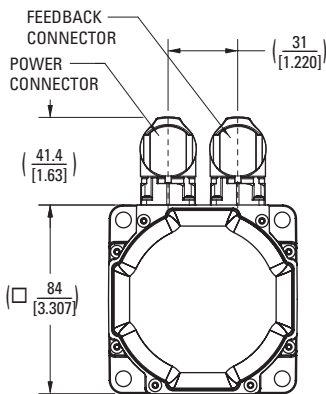

D-, 9- connector options

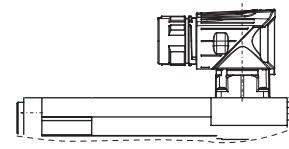
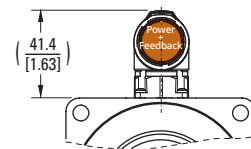
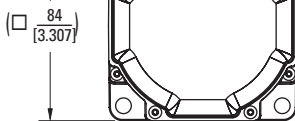

SHOWN WITH "C" CONNECTOR OPTION

M-, P- connector options

- AKM41 (103.1 [4.06])
- AKM42 (132.1 [5.20])
- AKM43 (161.1 [6.34])
- AKM44 (190.1 [7.48])

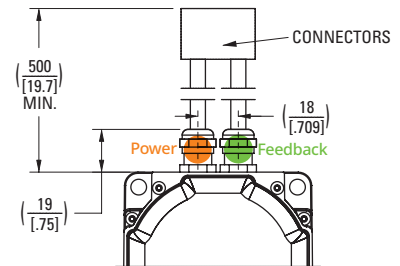
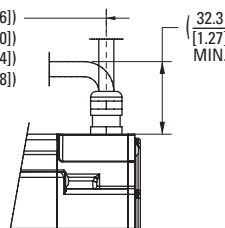

Shaft-keyway dimensions

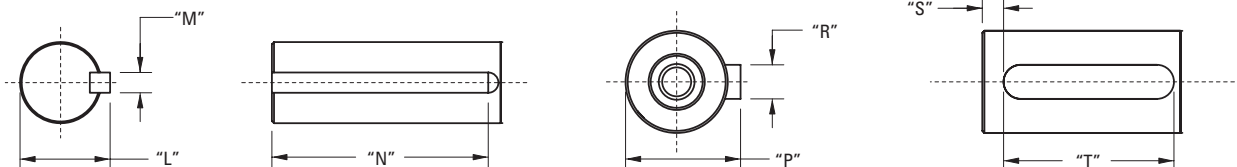

Dimensional data tables for callouts are located on the following page.

AKM4x Mounting Flange-Shaft Dimensional Data

Mounting Flange-Shaft	Hole Diameter "C"	Pilot Diameter "D"	Bolt Circle Dia. "E"	"F"	"H"	Shaft Diameter "J"	Shaft Length "K"	Shaft Dia. w/ Key "L"
AC	7 [0.276]	80 [3.1496]	100 [3.937]	-	D M5 DIN 332	19 [0.7480]	40.0 [1.57]	-
AN	7 [0.276]	80 [3.1496]	100 [3.937]	-	D M5 DIN 332	19 [0.7480]	40.0 [1.57]	-
BK	5.54 [0.218]	73.025 [2.8750]	98.43 [3.875]	-	-	15.875 [0.6250]	52.40 [2.063]	17.92 [0.706]
CC	5.54 [0.218]	60 [2.3622]	90 [3.543]	109 [4.291]	D M5 DIN 332	19 [0.7480]	40.0 [1.57]	-
CN	5.54 [0.218]	60 [2.3622]	90 [3.543]	109 [4.291]	D M5 DIN 332	19 [0.7480]	40.0 [1.57]	-
EK	5.54 [0.218]	73.025 [2.8750]	98.43 [3.875]	-	-	12.7 [0.5000]	31.75 [1.250]	14.09 [0.555]
GC	7 [0.276]	80 [3.1496]	100 [3.937]	-	D M5 DIN 332	14 [0.5512]	30 [1.18]	-
GN	7 [0.276]	80 [3.1496]	100 [3.937]	-	D M5 DIN 332	14 [0.5512]	30 [1.18]	-
HC	5.54 [0.218]	60 [2.3622]	90 [3.543]	109 [4.291]	D M5 DIN 332	14 [0.5512]	30 [1.18]	-
HN	5.54 [0.218]	60 [2.3622]	90 [3.543]	109 [4.291]	D M5 DIN 332	14 [0.5512]	30 [1.18]	-
KK	7 [0.276]	70 [2.7559]	90 [3.543]	109 [4.291]	-	16 [0.6299]	40.0 [1.57]	-

Mounting Flange-Shaft	Key Width "M"	Key Length "N"	Shaft Dia. w/ Key "P"	Key Width "R"	"S"	Key Length "T"	"U"	"V"	"W"
AC	-	-	21.5 [0.846]	6 [0.236]	4.00 [1.57]	32 [1.260]	0.040 [0.0015]	0.080 [0.0031]	0.080 [0.0031]
AN	-	-	-	-	-	-	0.040 [0.0015]	0.080 [0.0031]	0.080 [0.0031]
BK	4.762 [0.1875]	34.93 [1.375]	-	-	-	-	0.051 [0.0020]	0.10 [0.004]	0.10 [0.004]
CC	-	-	21.5 [0.846]	6 [0.236]	4.00 [1.57]	32 [1.260]	0.040 [0.0015]	0.080 [0.0031]	0.080 [0.0031]
CN	-	-	-	-	-	-	0.040 [0.0015]	0.080 [0.0031]	0.080 [0.0031]
EK	3.175 [0.1250]	19.05 [0.750]	-	-	-	-	0.051 [0.0020]	0.10 [0.004]	0.10 [0.004]
GC	-	-	16 [0.630]	5 [0.197]	6.00 [0.236]	20 [0.787]	0.040 [0.0015]	0.080 [0.0031]	0.080 [0.0031]
GN	-	-	-	-	-	-	0.040 [0.0015]	0.080 [0.0031]	0.080 [0.0031]
HC	-	-	16 [0.630]	5 [0.197]	6.00 [0.236]	20 [0.787]	0.040 [0.0015]	0.080 [0.0031]	0.080 [0.0031]
HN	-	-	-	-	-	-	0.040 [0.0015]	0.080 [0.0031]	0.080 [0.0031]
KK	5 [0.197]	30 [1.811]	-	-	-	-	0.051 [0.0020]	0.008 [0.0031]	0.008 [0.0031]

AKM4x Motor Length Dimensional Data

	No Brake (N)		
	X*	Y MAX	Z MAX
Connector	C-, 9-, G, M, D, P	C-, 9-, G, M, D, P	C-, 9-, G-
Feedback Option	R-, C-, CA, 1-, 2-, Ex, Ax, Dx, Lx, Gx	R-, C-, CA-, 1-, 2-, Ex, Ax, Dx, Lx	Gx
AKM41	96.4 [3.8]	118.8 [4.68]	136.8 [5.39]
AKM42	125.4 [4.94]	147.8 [5.82]	165.8 [6.53]
AKM43	154.4 [6.08]	176.8 [6.96]	194.8 [7.67]
AKM44	183.4 [7.22]	205.8 [8.1]	223.8 [8.81]

	Brake (2)		
	X*	Z MAX	
Connector	C-, 9-, G, M, D, P	C-, 9-, G, M, D, P	C-, 9-, G-
Feedback Option	R-, C-, CA, 1-, 2-, Ex, Ax, Dx, Lx, Gx	R-, C-, CA-, 1-, 2-, Ex, Ax, Dx, Lx	Gx
AKM41	96.4 [3.8]	152.3 [6]	170.3 [6.7]
AKM42	125.4 [4.94]	181.3 [7.14]	199.3 [7.85]
AKM43	154.4 [6.08]	210.3 [8.28]	228.3 [8.99]
AKM43	183.4 [7.22]	239.3 [9.42]	257.3 [10.13]

*For 0.5m shielded cable option (M or P), add 6.7 mm to "X"

Note 1: Dimensions are in mm [inches].

Note 2: Detailed Connector and Feedback option information can be found on pages 11-12.

Note 3: Product designed in metric. English conversions provided for reference only.

*Complete AKM series model nomenclature can be found on pages 10-12.

AKM[®] Servo Motor Specifications

AKM5x Performance Data – Up to 480 Vac (640 Vdc Bus) voltage

Parameters	Tol	Sym	Units	AKM51					AKM52					
				E	G	H	K	L	E	G	H	K	L	M
Max Rated Voltage ④	Max	-	Vac	480	480	480	240	240	480	480	480	480	480	240
			Vdc	640	640	640	320	320	640	640	640	640	640	320
Continuous Torque (Stall) for ΔT winding = 100°C ①②⑦⑧⑨	Nom	T _{CS}	Nm	4.70	4.75	4.79	4.9	4.89	8.34	8.43	8.48	8.6	8.67	8.60
			Ib-in	41.6	42	42.4	43.4	43.3	73.8	74.6	75.1	76.1	76.7	76.1
Continuous Current (Stall) for ΔT winding = 100°C ①②⑦⑧⑨	Nom	I _{CS}	Arms	2.75	4.84	6.0	9.4	11.9	2.99	4.72	5.9	9.3	11.6	13.1
Continuous Torque (Stall) for ΔT winding = 60°C ②	Nom	T _{CS}	Nm	3.76	3.8	3.83	3.92	3.91	6.67	6.74	6.78	6.88	6.94	6.88
			Ib-in	33.3	33.6	33.9	34.7	34.6	59.0	59.7	60.0	61	61.4	61.0
Max Mechanical Speed ⑤	Nom	N _{max}	rpm	6000	6000	6000	6000	6000	6000	6000	6000	6000	6000	6000
Peak Torque ①②	Nom	T _p	Nm	11.6	15.6	11.7	15.8	12.0	21.3	29.7	21.6	30	22.0	21.9
			Ib-in	103	138	104	140	106	189	263	191	266	195	194
Peak Current	Nom	I _p	Arms	8.24	24.2	18.0	47	35.7	9.00	23.6	17.7	46.5	34.8	39.4
Rated Torque (speed) ①②⑦⑧⑨⑩		T _{rtd}	Nm	-	-	-	-	-	-	-	-	-	-	-
			Ib-in	-	-	-	-	-	-	-	-	-	-	-
Rated Speed		N _{rtd}	rpm	-	-	-	-	-	-	-	-	-	-	-
Rated Power (speed) ①②⑦⑧⑨		P _{rtd}	kW	-	-	-	-	-	-	-	-	-	-	-
			Hp	-	-	-	-	-	-	-	-	-	-	-
Rated Torque (speed) ①②⑦⑧⑨⑩		T _{rtd}	Nm	-	-	4.46	4.15	3.95	-	-	-	-	7.89	-
			Ib-in	-	-	39.4	36.7	35.0	-	-	-	-	69.9	-
Rated Speed		N _{rtd}	rpm	-	-	1200	2500	3000	-	-	-	-	1500	-
Rated Power (speed) ①②⑦⑧⑨		P _{rtd}	kW	-	-	0.56	1.09	1.24	-	-	-	-	1.24	-
			Hp	-	-	0.75	1.46	1.66	-	-	-	-	1.66	-
Rated Torque (speed) ①②⑦⑧⑨⑩		T _{rtd}	Nm	4.41	4.02	3.87	2.35	2.00	-	7.69	7.53	6.8	6.40	5.20
			Ib-in	39.0	35.6	34.3	20.8	17.7	-	68.1	66.6	60.2	56.6	46.0
Rated Speed		N _{rtd}	rpm	1200	2500	3000	5500	6000	-	1500	1800	3000	3500	4500
Rated Power (speed) ①②⑦⑧⑨		P _{rtd}	kW	0.55	1.05	1.22	1.35	1.26	-	1.21	1.42	2.14	2.35	2.45
			Hp	0.74	1.41	1.63	1.81	1.69	-	1.62	1.90	2.86	3.15	3.28
Rated Torque (speed) ①②⑦⑧⑨⑩		T _{rtd}	Nm	3.98	2.62	1.97	-	-	7.61	7.06	6.26	3.9	3.27	-
			Ib-in	35.2	23.2	17.4	-	-	67.3	62.5	55.4	34.5	2.89	-
Rated Speed		N _{rtd}	rpm	2500	5000	6000	-	-	1500	2500	3500	5500	6000	-
Rated Power (speed) ①②⑦⑧⑨		P _{rtd}	kW	1.04	1.37	1.24	-	-	1.20	1.85	2.30	2.25	2.06	-
			Hp	1.40	1.84	1.66	-	-	1.60	2.48	3.08	3.01	2.76	-
Rated Torque (speed) ①②⑦⑧⑨⑩		T _{rtd}	Nm	3.80	1.94	1.97	-	-	7.28	6.66	5.77	3.25	3.27	-
			Ib-in	33.6	17.2	17.4	-	-	64.4	58.9	51.1	28.7	28.9	-
Rated Speed		N _{rtd}	rpm	3000	6000	6000	-	-	2000	3000	4000	6000	6000	-
Rated Power (speed) ①②⑦⑧⑨		P _{rtd}	kW	1.19	1.22	1.24	-	-	1.52	2.09	2.42	2.74	2.06	-
			Hp	1.60	1.63	1.66	-	-	20.4	2.8	3.24	2.04	2.76	-

See following page for notes.

AKM5x Performance Data – Up to 480 Vac (640 Vdc Bus) voltage (Continued)

Parameters	Tol	Sym	Units	AKM51					AKM52					
				E	G	H	K	L	E	G	H	K	L	M
Torque Constant ①	±10%	K _t	Nm/A _{rms}	1.72	0.99	0.80	0.52	0.41	2.79	1.79	1.44	0.93	0.75	0.66
			lb-in/A _{rms}	15.2	8.8	7.1	4.6	3.6	24.7	15.8	12.7	8.2	6.6	5.8
Back EMF Constant ⑥	±10%	K _e	V _{rms} /krpm	110	63.6	51.3	33.5	26.6	179	115.3	92.7	60.1	48.3	42.4
Motor Constant	Nom	K _m	N-m/√W	0.469	0.477	0.465	0.230	0.447	0.761	0.760	0.767	0.775	0.784	0.770
			lb-in/√W	4.15	4.24	4.12	2.04	3.96	6.73	6.71	6.79	6.83	6.94	6.81
Resistance (line-line) ⑥	±10%	R _m	ohm	8.98	2.87	1.97	3.4	0.56	8.96	3.7	2.35	0.96	0.61	0.49
Inductance (line-line)		L	mH	36.6	12.1	7.9	0.75	2.1	44.7	18.5	11.9	5	3.24	2.5
Inertia (includes Resolver feedback) ③	±10%	J _m	kg-cm ²	3.4					6.2					
			lb-in-s ²	3.0E-03					5.5E-03					
Optional Brake Inertia (additional)	±10%	J _m	kg-cm ²	0.166					0.166					
			lb-in-s ²	1.47E-04					1.47E-04					
Weight (w/o brake) ⑩		W	kg	4.2					5.8					
			lb	9.3					12.8					
Static Friction ①⑩		T _f	Nm	0.022					0.04					
			lb-in	0.19					0.35					
Viscous Damping ①		K _{dv}	Nm/krpm	0.033					0.042					
			lb-in/krpm	0.29					0.37					
Thermal Time Constant		TCT	minutes	20					24					
Thermal Resistance		R _{thw-a}	°C/W	0.68					0.56					
Operating Ambient Temperature Range ⑧ ④ ⑤			°C	-20 to 40					-20 to 40					
Pole Pairs				5					5					
Heat Sink Size				12"x12"x1/2" Aluminum Plate					12"x12"x1/2" Aluminum Plate					

Notes:

- ① Motor winding temperature rise, ΔT=100°C, at 40°C ambient.
- ② All data referenced to sinusoidal commutation.
- ③ Add parking brake if applicable for total inertia.
- ④ Motor with standard heat sink.
- ⑤ May be limited at some values of Vbus.
- ⑥ Measured at 25°C.
- ⑦ Brake option reduces continuous torque ratings by:
AKM51 = 0.15 Nm AKM52 = 0.26 Nm AKM53 = 0.35 Nm AKM54 = 0.43 Nm
- ⑧ Non-Resolver feedback options reduce continuous torque ratings by:
AKM51 = 0.15 Nm AKM52 = 0.34 Nm AKM53 = 0.58 Nm AKM54 = 0.86 Nm
- ⑨ Motors with non-resolver feedback and brake option, reduce continuous torque by:
AKM51 = 0.39 Nm AKM52 = 0.76 Nm AKM53 = 1.13 Nm AKM54 = 1.55 Nm
- ⑩ For motors with optional shaft seal, reduce torque shown by 0.13 Nm (1.2 lb-in), and increase T_f by the same amount.
- ⑪ Brake option increases weight by 1.2 kg (2.64 lb).
- ⑫ Motors can be operated up to 480 Vac. For performances curves at voltages, listed or unlisted, please use our online [Performance Curve Generator Tool](#).
- ⑬ Brake option will operate in this range in a non-condensing environment. See page 55 for more information.
- ⑭ "AA" or "AB" BiSS feedback lower limit is -15°C; all other feedbacks meet or exceed this range.
- ⑮ Operation outside of this range may be possible. Please contact Kollmorgen Customer Support with your application requirements.

Additional Notes:

See system data beginning on page 14 for typical torque/speed performance.

Additional windings may exist. Please contact Kollmorgen Customer Support for further information or to request custom winding options for your application requirements.

*Complete AKM series model nomenclature can be found on pages 10-12.

AKM[®] Servo Motor Specifications

AKM5x Performance Data – Up to 480 Vac (640 Vdc Bus) voltage

Parameters	Tol	Sym	Units	AKM53								AKM54				
				G	H	K	L	M	P	Q	G	H	K	L	N	P
Max Rated Voltage ⑩	Max	-	Vac	480	480	480	480	240	240	240	480	480	480	400	240	240
			Vdc	640	640	640	640	320	320	320	640	640	640	560	320	320
Continuous Torque (Stall) for ΔT winding = 100°C ①②⑦⑧⑨	Nom	T _{CS}	Nm	11.4	11.5	11.6	11.6	11.37	11.4	11.57	14.26	14.2	14.4	14.1	14.1	14.36
			lb-in	101	102	102.7	103	100.6	101	102.4	126.2	126	127	125	125	127.1
Continuous Current (Stall) for ΔT winding = 100°C ①②⑦⑧⑨	Nom	I _{CS}	A _{RMS}	4.77	6.6	9.4	11.8	13.4	19.1	21.1	5	5.5	9.7	12.5	17.8	19.6
Continuous Torque (Stall) for ΔT winding = 60°C ②	Nom	T _{CS}	Nm	9.10	9.21	9.28	9.28	9.1	9.10	9.26	11.41	11.5	11.5	11.3	11.3	11.49
			lb-in	80.5	81.5	82.1	82.1	80.5	80.5	82	101	102	102	100	100	101.7
Max Mechanical Speed ⑤	Nom	N _{max}	rpm	6000	6000	6000	6000	6000	6000	6000	6000	6000	6000	6000	6000	
Peak Torque ①②	Nom	T _p	Nm	29.7	30.0	42.6	30.3	42.1	29.8	42.6	54.4	37.5	38.4	37.5	37.6	54.5
			lb-in	263	266	377	268	373	264	377	481	332	340	332	333	482
Peak Current	Nom	I _p	A _{RMS}	14.3	19.8	47	35.4	67	57.4	105.5	25	16.5	29.2	37.5	53.4	98
75 Vdc Rated Torque (speed) ①②⑦⑧⑨⑩		T _{Rtd}	Nm	-	-	-	-	-	-	-	-	-	-	-	-	-
			lb-in	-	-	-	-	-	-	-	-	-	-	-	-	-
75 Vdc Rated Speed		N _{Rtd}	rpm	-	-	-	-	-	-	-	-	-	-	-	-	
75 Vdc Rated Power (speed) ①②⑦⑧⑨		P _{Rtd}	kW	-	-	-	-	-	-	-	-	-	-	-	-	
			Hp	-	-	-	-	-	-	-	-	-	-	-	-	
120 Vac (160 Vdc) Rated Torque (speed) ①②⑦⑧⑨⑩		T _{Rtd}	Nm	-	-	-	13.0	-	-	9.58	-	-	-	-	-	
			lb-in	-	-	-	115	-	-	84.8	-	-	-	-	-	-
120 Vac (160 Vdc) Rated Speed		N _{Rtd}	rpm	-	-	-	1200	-	-	2500	-	-	-	-	-	
120 Vac (160 Vdc) Rated Power (speed) ①②⑦⑧⑨		P _{Rtd}	kW	-	-	-	1.63	-	-	2.51	-	-	-	-	-	
			Hp	-	-	-	2.18	-	-	3.36	-	-	-	-	-	
240 Vac (320 Vdc) Rated Torque (speed) ①②⑦⑧⑨⑩		T _{Rtd}	Nm	10.7	10.5	10.1	9.59	8.72	5.88	4.99	-	13.4	12.7	11.5	9.85	9.23
			lb-in	94.5	93.0	89.4	84.9	77.2	52.0	44.2	-	118	112	102	87.2	81.7
240 Vac (320 Vdc) Rated Speed		N _{Rtd}	rpm	1000	1500	2000	2500	3000	5000	5500	-	1000	1800	2500	3500	4000
240 Vac (320 Vdc) Rated Power (speed) ①②⑦⑧⑨		P _{Rtd}	kW	1.12	1.65	2.12	2.51	2.74	3.08	2.87	-	1.4	2.39	3.00	3.61	3.87
			Hp	1.50	2.21	2.84	3.36	3.67	4.13	3.85	-	1.87	3.20	4.03	4.84	5.18
400 Vac (560 Vdc) Rated Torque (speed) ①②⑦⑧⑨⑩		T _{Rtd}	Nm	9.85	8.83	7.65	6.00	-	-	-	12.92	12.6	10.05	8.13	-	-
			lb-in	87.2	78.2	67.7	53.1	-	-	-	114.3	112	88.9	72.0	-	-
400 Vac (560 Vdc) Rated Speed		N _{Rtd}	rpm	2000	3000	4000	5000	-	-	-	1500	1800	3500	4500	-	-
400 Vac (560 Vdc) Rated Power (speed) ①②⑦⑧⑨		P _{Rtd}	kW	2.06	2.77	3.2	3.14	-	-	-	2.03	2.38	3.68	3.83	-	-
			Hp	2.77	3.72	4.3	4.21	-	-	-	2.72	3.18	4.94	5.14	-	-
480 Vac (640 Vdc) Rated Torque (speed) ①②⑦⑧⑨⑩		T _{Rtd}	Nm	9.50	8.82	6.85	4.05	-	-	-	12.28	12.2	9.25	-	-	-
			lb-in	84.0	78.0	60.6	35.8	-	-	-	108.7	108	81.9	-	-	-
480 Vac (640 Vdc) Rated Speed		N _{Rtd}	rpm	2400	3000	4500	6000	-	-	-	2000	2000	4000	-	-	-
480 Vac (640 Vdc) Rated Power (speed) ①②⑦⑧⑨		P _{Rtd}	kW	2.39	2.77	4.33	2.55	-	-	-	2.57	2.56	3.87	-	-	-
			Hp	3.20	3.71	5.83	3.41	-	-	-	3.45	3.43	5.19	-	-	-

See following page for notes.

AKM5x Performance Data – Up to 480 Vac (640 Vdc Bus) voltage (Continued)

Parameters	Tol	Sym	Units	AKM53							AKM54					
				G	H	K	L	M	P	Q	G	H	K	L	N	P
Torque Constant ①	±10%	K _t	Nm/A _{rms}	2.39	1.75	1.24	0.99	0.85	0.60	0.55	2.88	2.6	1.50	1.13	0.80	0.74
			lb-in/A _{rms}	21.2	15.5	11	8.8	7.5	5.3	4.9	25.5	22.7	13.3	10.0	7.1	6.5
Back EMF Constant ⑥	±10%	K _e	V _{rms} /krpm	154	112	79.8	63.6	54.7	38.4	35.5	185.3	166	96.6	72.9	51.3	47.3
Motor Constant	Nom	K _m	N-m/√W	0.979	0.986	0.983	0.973	0.972	0.926	0.422	1.164	1.19	1.18	1.14	1.14	1.163
			lb-in/√W	8.67	8.73	8.72	8.61	8.57	8.19	3.76	10.31	10.5	10.4	10.1	10.1	10.21
Resistance (line-line) ⑥	±10%	R _m	ohm	3.97	2.1	1.06	0.69	0.51	0.28	1.13	4.08	3.2	1.08	0.65	0.33	0.27
Inductance (line-line)		L	mH	21.3	11.4	5.7	3.64	2.7	1.3	0.21	22.9	18.3	6.2	3.5	1.8	1.5
Inertia (includes Resolver feedback) ③	±10%	J _m	kg-cm ²	9.1							12					
			lb-in-s ²	8.1E-03							0.011					
Optional Brake Inertia (additional)	±10%	J _m	kg-cm ²	0.166							0.166					
			lb-in-s ²	1.47E-04							1.47E-04					
Weight (w/o brake) ⑩		W	kg	7.4							9					
			lb	16.3							19.8					
Static Friction ①⑩		T _f	Nm	0.058							0.077					
			lb-in	0.51							0.68					
Viscous Damping ①		K _{dv}	Nm/krpm	0.052							0.061					
			lb-in/krpm	0.46							0.54					
Thermal Time Constant		TCT	minutes	28							31					
Thermal Resistance		R _{thw-a}	°C/W	0.50							0.45					
Operating Ambient Temperature Range ⑧ ⑭ ⑮			°C	-20 to 40							-20 to 40					
Pole Pairs				5							5					
Heat Sink Size				12"x12"x1/2" Aluminum Plate							12"x12"x1/2" Aluminum Plate					

Notes:

- ① Motor winding temperature rise, ΔT=100°C, at 40°C ambient.
- ② All data referenced to sinusoidal commutation.
- ③ Add parking brake if applicable for total inertia.
- ④ Motor with standard heat sink.
- ⑤ May be limited at some values of V_{bus}.
- ⑥ Measured at 25°C.
- ⑦ Brake option reduces continuous torque ratings by:
AKM51 = 0.15 Nm AKM52 = 0.26 Nm AKM53 = 0.35 Nm AKM54 = 0.43 Nm
- ⑧ Non-Resolver feedback options reduce continuous torque ratings by:
AKM51 = 0.15 Nm AKM52 = 0.34 Nm AKM53 = 0.58 Nm AKM54 = 0.86 Nm
- ⑨ Motors with non-resolver feedback and brake option, reduce continuous torque by:
AKM51 = 0.39 Nm AKM52 = 0.76 Nm AKM53 = 1.13 Nm AKM54 = 1.55 Nm
- ⑩ For motors with optional shaft seal, reduce torque shown by 0.13 Nm (1.2 lb-in), and increase T_f by the same amount.
- ⑪ Brake option increases weight by 1.2 kg (2.64 lb).
- ⑫ Motors can be operated up to 480 Vac. For performances curves at voltages, listed or unlisted, please use our online [Performance Curve Generator Tool](#).
- ⑬ Brake option will operate in this range in a non-condensing environment. See page 55 for more information.
- ⑭ "AA" or "AB" BiSS feedback lower limit is -15°C; all other feedbacks meet or exceed this range.
- ⑮ Operation outside of this range may be possible. Please contact Kollmorgen Customer Support with your application requirements.

Additional Notes:

See system data beginning on page 14 for typical torque/speed performance.

Additional windings may exist. Please contact Kollmorgen Customer Support for further information or to request custom winding options for your application requirements.

*Complete AKM series model nomenclature can be found on pages 10-12.

AKM[®] Servo Motor Specifications

AKM5x Frame Dimensional Drawings

AKM 2D/3D CAD models can be found here: [AKM CAD Models](#)

C- connector option

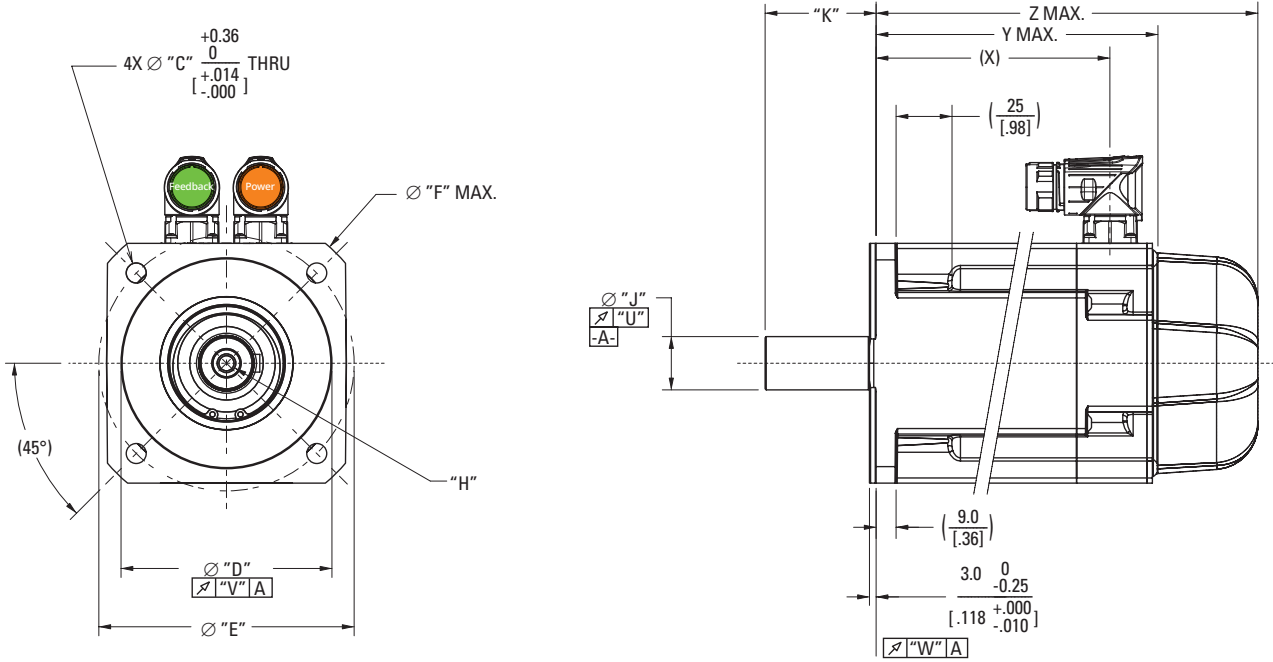

G- connector option

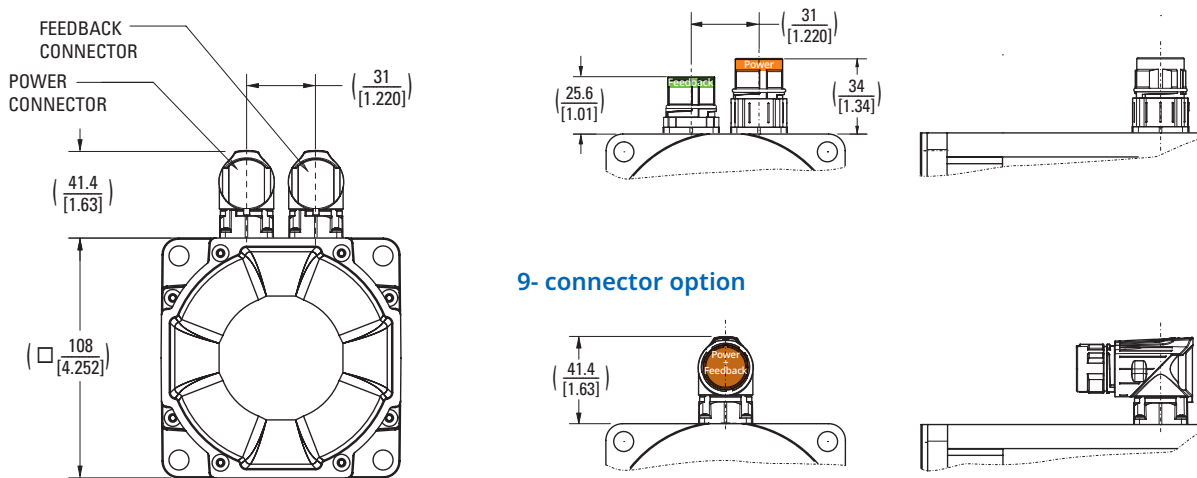

9- connector option

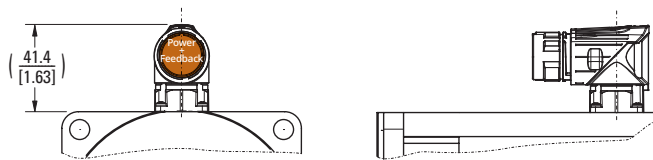

Shaft-keyway dimensions

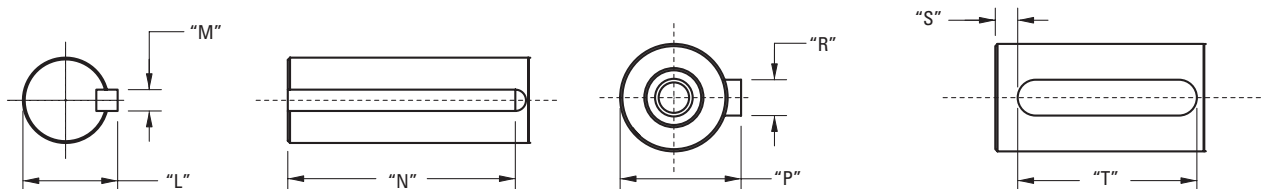

Dimensional data tables for callouts are located on the following page.

AKM5x Mounting Flange-Shaft Dimensional Data

Mounting Flange-Shaft	Hole Diameter "C"	Pilot Diameter "D"	Bolt Circle Dia. "E"	"F"	"H"	Shaft Diameter "J"	Shaft Length "K"	Shaft Dia. w/ Key "L"
AC	9 [0.354]	110 [4.3307]	130 [5.118]	-	D M8 DIN 332	24 [0.9449]	50.0 [1.97]	-
AN	9 [0.354]	110 [4.3307]	130 [5.118]	-	D M8 DIN 332	24 [0.9449]	50.0 [1.97]	-
BK	8.33 [0.328]	55.563 [2.1874]	125.73 [4.950]	-	-	19.05 [0.7500]	57.15 [2.250]	21.15 [0.83]
CC	9 [0.354]	95 [3.7402]	115 [4.528]	140 [5.512]	D M8 DIN 332	24 [0.9449]	50.0 [1.97]	-
CN	9 [0.354]	95 [3.7402]	115 [4.528]	140 [5.512]	D M8 DIN 332	24 [0.9449]	50.0 [1.97]	-
DK	8.33 [0.328]	63.5 [2.500]	127 [5.000]	-	-	19.05 [0.7500]	57.15 [2.250]	21.15 [0.83]
EK	8.33 [0.328]	55.563 [2.1874]	125.73 [4.950]	-	-	15.875 [0.6250]	44.45 [1.750]	17.91 [0.705]
GC	9 [0.354]	110 [4.3307]	130 [5.118]	-	D M6 DIN 332	19 [0.7480]	40 [1.57]	-
GN	9 [0.354]	110 [4.3307]	130 [5.118]	-	D M6 DIN 332	19 [0.7480]	40.0 [1.57]	-
HC	9 [0.354]	95 [3.7402]	115 [4.528]	140 [5.512]	D M6 DIN 332	19 [0.7480]	40 [1.57]	-
HN	9 [0.354]	95 [3.7402]	115 [4.528]	140 [5.512]	D M6 DIN 332	19 [0.7480]	40.0 [1.57]	-

Mounting Flange-Shaft	Key Width "M"	Key Length "N"	Shaft Dia. w/ Key "P"	Key Width "R"	"S"	Key Length "T"	"U"	"V"	"W"
AC	-	-	27 [1.063]	8 [0.3150]	5.00 [0.197]	40 [1.575]	0.040 [0.0015]	0.100 [0.0039]	0.100 [0.0039]
AN	-	-	-	-	-	-	0.040 [0.0015]	0.100 [0.0039]	0.100 [0.0039]
BK	4.763 [0.1875]	38.1 [1.500]	-	-	-	-	0.051 [0.0020]	0.10 [0.004]	0.10 [0.004]
CC	-	-	27 [1.063]	8 [0.3150]	5.00 [0.197]	40 [1.575]	0.040 [0.0015]	0.080 [0.0031]	0.080 [0.0031]
CN	-	-	-	-	-	-	0.040 [0.0015]	0.080 [0.0031]	0.080 [0.0031]
DK	4.763 [0.1875]	34.93 [1.375]	-	-	-	-	0.051 [0.0020]	0.05 [0.002]	0.10 [0.004]
EK	4.763 [0.1875]	38.1 [1.500]	-	-	-	-	0.051 [0.0020]	0.10 [0.004]	0.10 [0.004]
GC	-	-	21.5 [0.846]	6 [0.236]	4.00 [0.157]	32 [1.260]	0.040 [0.0015]	0.080 [0.0031]	0.080 [0.0031]
GN	-	-	-	-	-	-	-	-	-
HC	-	-	21.5 [0.846]	6 [0.236]	4.00 [0.157]	32 [1.260]	0.040 [0.0015]	0.080 [0.0031]	0.080 [0.0031]
HN	-	-	-	-	-	-	-	-	-

AKM5x Motor Length Dimensional Data

Connector	No Brake (N)		
	X	Y MAX	Z MAX
	C-, 9-, G	C-, 9-, G	C-, 9-, G-
Feedback Option	R-, C-, CA, 1-, 2-, Ex, Ax, Dx, Lx, Gx	R-, C-, CA-, 1-, 2-, Ex	Ax, Dx, Lx, Gx
AKM51	105.3 [4.15]	127.5 [5.02]	146 [5.75]
AKM52	136.3 [5.37]	158.5 [6.24]	177 [6.97]
AKM53	167.3 [6.59]	189.5 [7.46]	208 [8.19]
AKM54	198.3 [7.81]	220.5 [8.68]	239 [9.41]

Connector	Brake (2)		
	X	Z MAX	
	C-, 9-, G	C-, 9-, G	C-, 9-, G-
Feedback Option	R-, C-, CA, 1-, 2-, Ex, Ax, Dx, Lx, Gx	R-, C-, CA-, 1-, 2-, Ex	Ax, Dx, Lx, Gx
AKM51	105.3 [4.15]	172.5 [6.79]	189 [7.44]
AKM52	136.3 [5.37]	203.5 [8.01]	220 [8.66]
AKM53	167.3 [6.59]	234.5 [9.23]	251 [9.88]
AKM54	198.3 [7.81]	265.5 [10.45]	282 [11.1]

Note 1: Dimensions are in mm [inches].

Note 2: Detailed Connector and Feedback option information can be found on pages 11-12.

Note 3: Product designed in metric. English conversions provided for reference only.

*Complete AKM series model nomenclature can be found on pages 10-12.

AKM[®] Servo Motor Specifications

AKM6x Performance Data – Up to 480 Vac (640 Vdc Bus) voltage

Parameters	Tol	Sym	Units	AKM62								AKM63					
				G	H	K	L	M	P	Q	G	H	K	L	M	N	Q
Max Rated Voltage ⑩	Max	-	Vac	480	480	480	480	480	240	240	480	480	480	480	480	480	240
			Vdc	640	640	640	640	640	320	320	640	640	640	640	640	640	640
Continuous Torque (Stall) for ΔT winding = 100°C ①②⑦⑧⑨	Nom	T _{CS}	Nm	11.9	11.9	12.2	12.2	12.2	12.3	12.0	16.5	16.6	16.8	16.8	17.0	17	16.7
			lb-in	105	105	108	108	108	109	106	146	147	149	149	150	150	148
Continuous Current (Stall) for ΔT winding = 100°C ①②⑦⑧⑨	Nom	I _{CS}	A _{rms}	4.9	5.4	9.6	12.0	13.4	18.8	21.8	4.5	5.6	9.9	11.1	13.8	17.4	22.4
Continuous Torque (Stall) for ΔT winding = 60°C ②	Nom	T _{CS}	Nm	9.5	9.5	9.8	9.8	9.72	9.8	9.6	13.2	13.3	13.4	13.4	13.6	13.6	13.4
			lb-in	84	84	87	87	86.0	87	85	117	118	119	119	120	120	119
Max Mechanical Speed ⑤	Nom	N _{max}	rpm	6000	6000	6000	6000	6000	6000	6000	6000	6000	6000	6000	6000	6000	6000
Peak Torque ①②	Nom	T _p	Nm	40.9	29.6	41.2	30.1	30.2	41.4	29.8	58.9	42.1	59.4	42.6	43.0	59.8	42.4
			lb-in	362	262	365	266	267	366	264	521	373	526	377	381	529	374
Peak Current	Nom	I _p	A _{rms}	24.3	16.2	48	36.0	40.3	94.5	65.4	22.5	16.8	49.5	33.3	41.4	87	67.2
75 Vdc Rated Torque (speed) ①②⑦⑧⑨⑩		T _{rtd}	Nm	-	-	-	-	-	-	-	-	-	-	-	-	-	-
			lb-in	-	-	-	-	-	-	-	-	-	-	-	-	-	-
75 Vdc Rated Speed		N _{rtd}	rpm	-	-	-	-	-	-	-	-	-	-	-	-	-	-
75 Vdc Rated Power (speed) ①②⑦⑧⑨		P _{rtd}	kW	-	-	-	-	-	-	-	-	-	-	-	-	-	-
			Hp	-	-	-	-	-	-	-	-	-	-	-	-	-	-
120 Vac (160 Vdc) Rated Torque (speed) ①②⑦⑧⑨⑩		T _{rtd}	Nm	-	-	-	-	-	-	-	-	-	-	-	-	-	-
			lb-in	-	-	-	-	-	-	-	-	-	-	-	-	-	-
120 Vac (160 Vdc) Rated Speed		N _{rtd}	rpm	-	-	-	-	-	-	-	-	-	-	-	-	-	-
120 Vac (160 Vdc) Rated Power (speed) ①②⑦⑧⑨		P _{rtd}	kW	-	-	-	-	-	-	-	-	-	-	-	-	-	-
			Hp	-	-	-	-	-	-	-	-	-	-	-	-	-	-
240 Vac (320 Vdc) Rated Torque (speed) ①②⑦⑧⑨⑩		T _{rtd}	Nm	-	10.8	10.4	10.0	9.50	8.1	6.5	-	-	14.9	14.2	14.3	13	11.9
			lb-in	-	99	92	89	84.1	72	58	-	-	132	126	127	115	105
240 Vac (320 Vdc) Rated Speed		N _{rtd}	rpm	-	1000	2000	2500	3000	4500	5500	-	-	1500	1500	2000	3000	3500
240 Vac (320 Vdc) Rated Power (speed) ①②⑦⑧⑨		P _{rtd}	kW	-	1.17	2.18	2.62	2.98	3.82	3.74	-	-	2.34	2.23	2.99	4.08	4.36
			Hp	-	1.57	2.92	3.51	4.00	5.12	5.02	-	-	3.14	2.99	4.01	5.47	5.85
400 Vac (560 Vdc) Rated Torque (speed) ①②⑦⑧⑨⑩		T _{rtd}	Nm	10.4	10.2	9	7.42	5.70	-	-	14.9	14.6	12.9	12.9	11.3	9.6	-
			lb-in	92	90.3	80	65.7	50.4	-	-	132	129	114	114	100	85	-
400 Vac (560 Vdc) Rated Speed		N _{rtd}	rpm	1800	2000	3500	5000	6000	-	-	1200	1500	3000	3000	4000	5000	-
400 Vac (560 Vdc) Rated Power (speed) ①②⑦⑧⑨		P _{rtd}	kW	1.96	2.14	3.3	3.89	3.58	-	-	1.87	2.29	4.05	4.05	4.73	5.03	-
			Hp	2.63	2.86	4.42	5.21	4.80	-	-	2.51	3.08	5.43	5.43	6.34	6.74	-
480 Vac (640 Vdc) Rated Torque (speed) ①②⑦⑧⑨⑩		T _{rtd}	Nm	10.2	9.9	8	5.74	5.70	-	-	14.6	14.2	12	12.0	10.5	7	-
			lb-in	90	87.6	71	50.8	50.4	-	-	129	126	106	106	92.9	62	-
480 Vac (640 Vdc) Rated Speed		N _{rtd}	rpm	2000	2400	4500	6000	6000	-	-	1500	1800	3500	3500	4500	6000	-
480 Vac (640 Vdc) Rated Power (speed) ①②⑦⑧⑨		P _{rtd}	kW	2.14	2.49	3.77	3.61	3.58	-	-	2.29	2.68	4.4	4.4	4.95	4.4	-
			Hp	2.86	3.34	5.05	4.84	4.80	-	-	3.07	3.59	5.9	5.90	6.63	5.9	-

See following page for notes.

AKM6x Performance Data – Up to 480 Vac (640 Vdc Bus) voltage (Continued)

Parameters	Tol	Sym	Units	AKM62							AKM63						
				G	H	K	L	M	P	Q	G	H	K	L	M	N	Q
Torque Constant ①	±10%	K _t	Nm/A _{rms}	2.47	2.2	1.28	1.0	0.91	0.66	0.60	3.7	3.00	1.71	1.5	1.24	0.98	0.75
			lb-in/A _{rms}	21.9	19.5	11.3	8.85	8.1	5.8	5.3	32.7	26.6	15.1	13.3	11.0	8.7	7.1
Back EMF Constant ②	±10%	K _e	V _{rms} /krpm	158.7	142	82.1	65.5	58.8	42.2	35.5	238.1	191.5	109.9	98.2	79.9	63.3	48.3
Motor Constant	Nom	K _m	N-m/√W	0.992	0.989	1.006	0.949	0.984	0.984	1.00	1.288	1.32	1.308	1.26	1.30	1.281	1.28
			lb-in/√W	8.80	8.75	8.88	8.40	8.71	8.65	8.85	11.38	11.7	11.55	11.2	11.5	11.37	11.3
Resistance (line-line) ⑥	±10%	R _m	ohm	4.13	3.3	1.08	0.74	0.57	0.3	0.24	5.5	3.43	1.14	0.94	0.61	0.39	0.23
Inductance (line-line)		L	mH	31.7	25.4	8.5	5.4	4.4	2.2	1.6	43.5	28.1	9.3	7.4	4.9	3.1	1.8
Inertia (includes Resolver feedback) ③	±10%	J _m	kg-cm ²	17							24						
			lb-in-s ²	0.015							0.021						
Optional Brake Inertia (additional)	±10%	J _m	kg-cm ²	0.668							0.668						
			lb-in-s ²	5.91E-04							5.91E-04						
Weight (w/o brake) ⑩		W	kg	8.9							11.1						
			lb	19.6							24.4						
Static Friction ⑪⑫		T _f	Nm	0.05							0.1						
			lb-in	0.44							0.9						
Viscous Damping ⑬		K _{dv}	Nm/krpm	0.04							0.06						
			lb-in/krpm	0.35							0.53						
Thermal Time Constant		TCT	minutes	20							25						
Thermal Resistance		R _{thw-a}	°C/W	0.46							0.41						
Operating Ambient Temperature Range ⑭ ⑮			°C	-20 to 40							-20 to 40						
Pole Pairs				5							5						
Heat Sink Size				18"x18"x1/2" Aluminum Plate							18"x18"x1/2" Aluminum Plate						

Notes:

- ① Motor winding temperature rise, ΔT=100°C, at 40°C ambient.
- ② All data referenced to sinusoidal commutation.
- ③ Add parking brake if applicable for total inertia.
- ④ Motor with standard heat sink.
- ⑤ May be limited at some values of V_{bus}.
- ⑥ Measured at 25°C.
- ⑦ Brake option reduces continuous torque ratings by:
AKM62 = 0.5 Nm AKM63 = 0.9 Nm AKM64 = 1.3 Nm AKM65 = 1.7 Nm
- ⑧ Non-Resolver feedback options reduce continuous torque ratings by:
AKM62 = 0.9 Nm AKM63 = 1.2 Nm AKM64 = 1.5 Nm AKM65 = 1.8 Nm
- ⑨ Motors with non-resolver feedback and brake option, reduce continuous torque by:
AKM62 = 1.6 Nm AKM63 = 2.4 Nm AKM64 = 3.1 Nm AKM65 = 4.0 Nm
- ⑩ For motors with optional shaft seal, reduce torque shown by 0.25 Nm (2.21 lb-in), and increase T_f by the same amount.
- ⑪ Brake option increases weight by 2.2 kg (4.84 lb).
- ⑫ Motors can be operated up to 480 Vac. For performances curves at voltages, listed or unlisted, please use our online [Performance Curve Generator Tool](#).
- ⑬ Brake option will operate in this range in a non-condensing environment. See page 55 for more information.
- ⑭ "AA" or "AB" BiSS feedback lower limit is -15°C; all other feedbacks meet or exceed this range.
- ⑮ Operation outside of this range may be possible. Please contact Kollmorgen Customer Support with your application requirements.

Additional Notes:

See system data beginning on page 14 for typical torque/speed performance.

Additional windings may exist. Please contact Kollmorgen Customer Support for further information or to request custom winding options for your application requirements.

*Complete AKM series model nomenclature can be found on pages 10-12.

AKM[®] Servo Motor Specifications

AKM6x Performance Data – Up to 480 Vac (640 Vdc Bus) voltage

Parameters	Tol	Sym	Units	AKM64				AKM65				
				K	L	P	Q	K	L	M	N	P
Max Rated Voltage ①	Max	-	Vac	480	480	480	480	480	480	480	480	480
			Vdc	640	640	640	640	640	640	640	640	640
Continuous Torque (Stall) for ΔT winding = 100°C ①②⑦⑧⑨	Nom	T _{CS}	Nm	20.8	21.0	20.4	20.6	24.8	25.0	25.0	24.3	24.5
			lb-in	184	186	181	182	219	221	221	215	217
Continuous Current (Stall) for ΔT winding = 100°C ①②⑦⑧⑨	Nom	I _{CS}	A _{RMS}	9.2	12.8	18.6	20.7	9.8	12.2	13.6	17.8	19.8
			Nm	16.6	16.8	16.3	16	19.8	20	20.0	19.4	19.6
Continuous Torque (Stall) for ΔT winding = 60°C ②	Nom	T _{CS}	lb-in	147	149	144	142	175	177	177	172	173
			rpm	6000	6000	6000	6000	6000	6000	6000	6000	6000
Peak Torque ①②	Nom	T _p	Nm	53.5	54.1	75.2	53.2	92.4	65.2	65.2	91.6	65.2
			lb-in	473	479	666	471	818	577	577	811	577
Peak Current	Nom	I _p	A _{RMS}	27.5	38.4	93	62.1	49	36.6	40.9	89	59.4
			Nm	-	-	-	-	-	-	-	-	-
Rated Torque (speed) ①②⑦⑧⑨⑩		T _{rtd}	lb-in	-	-	-	-	-	-	-	-	-
			rpm	-	-	-	-	-	-	-	-	-
Rated Speed		N _{rtd}	kW	-	-	-	-	-	-	-	-	-
			Hp	-	-	-	-	-	-	-	-	-
Rated Power (speed) ①②⑦⑧⑨		P _{rtd}	Nm	-	-	-	-	-	-	-	-	-
			lb-in	-	-	-	-	-	-	-	-	-
Rated Torque (speed) ①②⑦⑧⑨⑩		T _{rtd}	rpm	-	-	-	-	-	-	-	-	-
			kW	-	-	-	-	-	-	-	-	-
Rated Speed		N _{rtd}	Hp	-	-	-	-	-	-	-	-	-
			rpm	-	-	-	-	-	-	-	-	-
Rated Power (speed) ①②⑦⑧⑨		P _{rtd}	Nm	18.8	18.4	16	15.3	22.8	22.4	21.9	19.8	19.1
			lb-in	166	163	142	135	202	198	194	175	169
Rated Torque (speed) ①②⑦⑧⑨⑩		T _{rtd}	rpm	1200	1500	2500	3000	1000	1300	1500	2000	2400
			kW	2.36	2.89	4.19	4.81	2.39	3.05	3.44	4.15	4.8
Rated Speed		N _{rtd}	Hp	3.17	3.87	5.62	6.45	3.2	4.09	4.61	5.56	6.44
			rpm	2000	3000	4500	5000	2000	2500	2700	3500	4000
Rated Power (speed) ①②⑦⑧⑨		P _{rtd}	Nm	17.2	15.6	11.9	10.7	20.2	19.2	18.8	16	14.9
			lb-in	152	138	105	95	179	170	166	142	132
Rated Torque (speed) ①②⑦⑧⑨⑩		T _{rtd}	rpm	2000	3000	4500	5000	2000	2500	2700	3500	4000
			kW	3.60	4.90	5.61	5.6	4.23	5.03	5.32	5.86	6.24
Rated Speed		N _{rtd}	Hp	4.83	6.57	7.52	7.51	5.67	6.74	7.13	7.86	8.37
			rpm	2500	3500	5500	6000	2200	2800	3000	4000	5000
Rated Power (speed) ①②⑦⑧⑨		P _{rtd}	Nm	16.3	14.4	9	7.4	19.7	18.6	18.1	14.7	11.6
			lb-in	144	127	80	66	174	165	160	130	103
Rated Torque (speed) ①②⑦⑧⑨⑩		T _{rtd}	rpm	2500	3500	5500	6000	2200	2800	3000	4000	5000
			kW	4.27	5.28	5.18	4.65	4.54	5.37	5.69	6.16	6.08
Rated Speed		N _{rtd}	Hp	5.72	7.07	6.95	6.23	6.08	7.2	7.62	8.25	8.14
			rpm	2500	3500	5500	6000	2200	2800	3000	4000	5000
Rated Power (speed) ①②⑦⑧⑨		P _{rtd}	Nm	16.3	14.4	9	7.4	19.7	18.6	18.1	14.7	11.6
			lb-in	144	127	80	66	174	165	160	130	103
Rated Torque (speed) ①②⑦⑧⑨⑩		T _{rtd}	rpm	2500	3500	5500	6000	2200	2800	3000	4000	5000
			kW	4.27	5.28	5.18	4.65	4.54	5.37	5.69	6.16	6.08
Rated Speed		N _{rtd}	Hp	5.72	7.07	6.95	6.23	6.08	7.2	7.62	8.25	8.14
			rpm	2500	3500	5500	6000	2200	2800	3000	4000	5000

See following page for notes.

AKM6x Performance Data – Up to 480 Vac (640 Vdc Bus) voltage (Continued)

Parameters	Tol	Sym	Units	AKM64				AKM65				
				K	L	P	Q	K	L	M	N	P
Torque Constant ①	±10%	K _t	Nm/A _{rms}	2.28	1.66	1.1	1.0	2.54	2.1	1.85	1.38	1.3
			lb-in/A _{rms}	20.2	14.7	9.7	8.85	22.5	18.6	16.4	12.2	11.5
Back EMF Constant ②	±10%	K _e	V _{rms} /krpm	147	107	71	64.4	163.7	133	119	88.8	80.5
Motor Constant	Nom	K _m	N-m/√W	1.57	1.57	1.497	1.44	1.785	1.81	1.77	1.718	1.75
			lb-in/√W	13.9	13.9	13.20	12.8	15.81	16.0	15.6	15.19	15.4
Resistance (line-line) ⑥	±10%	R _m	ohm	1.41	0.75	0.36	0.32	1.35	0.90	0.73	0.43	0.37
Inductance (line-line)		L	mH	11.8	6.2	2.8	2.3	11.4	7.6	6.1	3.4	2.8
Inertia (includes Resolver feedback) ③	±10%	J _m	kg-cm ²	32				40				
			lb-in-s ²	0.028				0.035				
Optional Brake Inertia (additional)	±10%	J _m	kg-cm ²	0.668				0.668				
			lb-in-s ²	5.91E-04				5.91E-04				
Weight (w/o brake) ⑩		W	kg	13.3				15.4				
			lb	29.3				33.9				
Static Friction ⑪⑫		T _f	Nm	0.15				0.2				
			lb-in	1.3				1.8				
Viscous Damping ⑬		K _{dv}	Nm/krpm	0.08				0.1				
			lb-in/krpm	0.71				0.9				
Thermal Time Constant		TCT	minutes	30				35				
Thermal Resistance		R _{thw-a}	°C/W	0.38				0.35				
Operating Ambient Temperature Range ⑭ ⑮			°C	-20 to 40				-20 to 40				
Pole Pairs				5				5				
Heat Sink Size				18"x18"x1/2" Aluminum Plate				18"x18"x1/2" Aluminum Plate				

Notes:

- ① Motor winding temperature rise, ΔT=100°C, at 40°C ambient.
- ② All data referenced to sinusoidal commutation.
- ③ Add parking brake if applicable for total inertia.
- ④ Motor with standard heat sink.
- ⑤ May be limited at some values of V_{bus}.
- ⑥ Measured at 25°C.
- ⑦ Brake option reduces continuous torque ratings by:
AKM62 = 0.5 Nm AKM63 = 0.9 Nm AKM64 = 1.3 Nm AKM65 = 1.7 Nm
- ⑧ Non-Resolver feedback options reduce continuous torque ratings by:
AKM62 = 0.9 Nm AKM63 = 1.2 Nm AKM64 = 1.5 Nm AKM65 = 1.8 Nm
- ⑨ Motors with non-resolver feedback and brake option, reduce continuous torque by:
AKM62 = 1.6 Nm AKM63 = 2.4 Nm AKM64 = 3.1 Nm AKM65 = 4.0 Nm
- ⑩ For motors with optional shaft seal, reduce torque shown by 0.25 Nm (2.21 lb-in), and increase T_f by the same amount.
- ⑪ Brake option increases weight by 2.2 kg (4.84 lb).
- ⑫ Motors can be operated up to 480 Vac. For performances curves at voltages, listed or unlisted, please use our online [Performance Curve Generator Tool](#).
- ⑬ Brake option will operate in this range in a non-condensing environment. See page 55 for more information.
- ⑭ "AA" or "AB" BiSS feedback lower limit is -15°C; all other feedbacks meet or exceed this range.
- ⑮ Operation outside of this range may be possible. Please contact Kollmorgen Customer Support with your application requirements.

Additional Notes:

See system data beginning on page 14 for typical torque/speed performance.

Additional windings may exist. Please contact Kollmorgen Customer Support for further information or to request custom winding options for your application requirements.

*Complete AKM series model nomenclature can be found on pages 10-12.

AKM[®] Servo Motor Specifications

AKM6x Frame Dimensional Drawings

AKM 2D/3D CAD models can be found here: [AKM CAD Models](#)

C- connector option

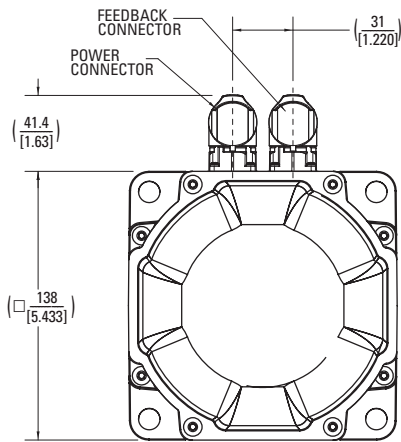
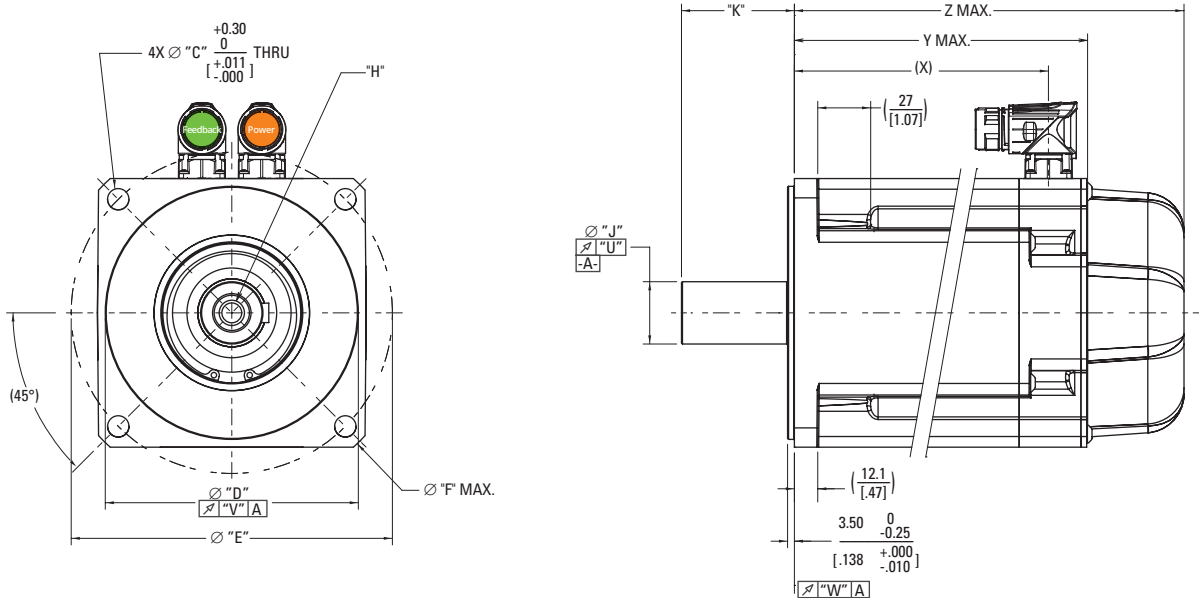

G- connector option

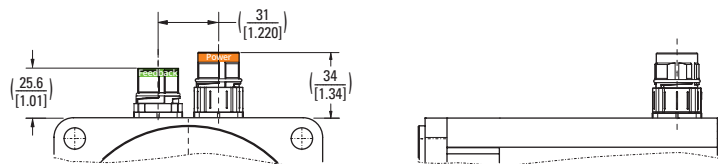

9- connector option

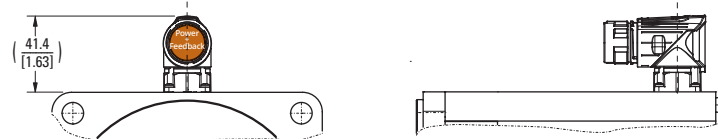

Shaft-keyway dimensions

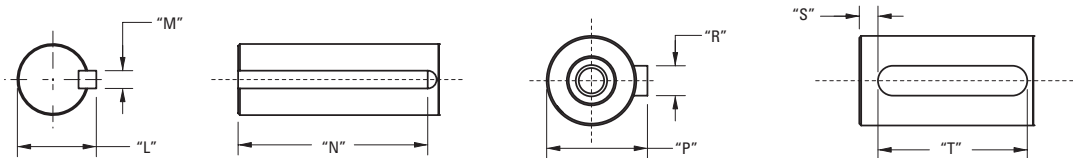

Dimensional data tables for callouts are located on the following page.

AKM6x Mounting Flange-Shaft Dimensional Data

Mounting Flange-Shaft	Hole Diameter "C"	Pilot Diameter "D"	Bolt Circle Dia. "E"	"F"	"H"	Shaft Diameter "J"	Shaft Length "K"	Shaft Dia. w/ Key "L"
AC	11.00 [0.433]	130 [5.1181]	165.00 [6.496]	-	D M12 DIN 332	32 [1.2598]	58 [2.28]	-
AN	11.00 [0.433]	130 [5.1181]	165.00 [6.496]	-	D M12 DIN 332	32 [1.2598]	58 [2.28]	-
GC	11.00 [0.433]	130 [5.1181]	165.00 [6.496]	-	D M8 DIN 332	24 [0.9449]	50 [1.97]	-
GN	11.00 [0.433]	130 [5.1181]	165.00 [6.496]	-	D M8 DIN 332	24 [0.9449]	50 [1.97]	-
KK	9.00 [0.354]	110 [4.3307]	145.00 [5.709]	165 [6.496]	-	28 [1.1024]	60 [2.36]	31 [1.220]
LK	3/18 - 16 UNC-2B	114.3 [4.5000]	149.225 [5.875]	165 [6.496]	-	28.580 [1.1250]	69.85 [2.75]	31.39 [1.236]

Mounting Flange-Shaft	Key Width "M"	Key Length "N"	Shaft Dia. w/ Key "P"	Key Width "R"	"S"	Key Length "T"	"U"	"V"	"W"
AC	-	-	35 [1.378]	10 [0.3937]	5.00 [0.197]	45 [1.772]	0.050 [0.0019]	0.100 [0.0039]	0.100 [0.0039]
AN	-	-	-	-	-	-	0.050 [0.0019]	0.100 [0.0039]	0.100 [0.0039]
GC	-	-	27 [1.063]	8 [0.3150]	5.00 [0.197]	40 [1.575]	0.050 [0.0019]	0.100 [0.0039]	0.100 [0.0039]
GN	-	-	-	-	-	-	0.050 [0.0019]	0.100 [0.0039]	0.100 [0.0039]
KK	8 [0.3150]	50 [1.969]	-	-	-	-	0.050 [0.0019]	0.100 [0.0039]	0.100 [0.0039]
LK	6.35 [2.75]	38.1 [1.500]	-	-	-	-	0.050 [0.0019]	0.100 [0.0039]	0.100 [0.0039]

AKM6x Motor Length Dimensional Data

	No Brake (N)		
	X	Y MAX	Z MAX
	C-, 9-, G	C-, 9-, G	C-, 9-, G-
Connector	C-, 9-, G	C-, 9-, G	C-, 9-, G-
Feedback Option	R-, C-, CA, 1-, 2-, Ex, Ax, Dx, Lx, Gx	R-, C-, CA-, 1-, 2-, Ex	Ax, Dx, Lx, Gx
AKM62	130.5 [5.14]	153.7 [6.05]	172.2 [6.78]
AKM63	155.5 [6.12]	178.7 [7.04]	197.2 [7.76]
AKM64	180.5 [7.11]	203.7 [8.02]	222.2 [8.75]
AKM65	205.5 [8.09]	228.7 [9]	247.2 [9.73]

	Brake (2)		
	X	Z MAX	
	C-, 9-, G	C-, 9-, G	C-, 9-, G-
Connector	C-, 9-, G	C-, 9-, G	C-, 9-, G-
Feedback Option	R-, C-, CA, 1-, 2-, Ex, Ax, Dx, Lx, Gx	R-, C-, CA-, 1-, 2-, Ex	Ax, Dx, Lx, Gx
AKM62	130.5 [5.14]	200.7 [7.9]	219.7 [8.65]
AKM63	155.5 [6.12]	225.7 [8.89]	244.7 [9.63]
AKM64	180.5 [7.11]	250.7 [9.87]	269.7 [10.62]
AKM65	205.5 [8.09]	275.7 [10.85]	294.7 [11.6]

Note 1: Dimensions are in mm [inches].

Note 2: Detailed Connector and Feedback option information can be found on pages 11-12.

Note 3: Product designed in metric. English conversions provided for reference only.

*Complete AKM series model nomenclature can be found on pages 10-12.

AKM[®] Servo Motor Specifications

AKM7x Performance Data – Up to 480 Vac (640 Vdc Bus) voltage

Parameters	Tol	Symbol	Units	AKM72					AKM73				AKM74			
				K	L	M	P	Q	L	M	P	Q	L	P	Q	
Max Rated Voltage ⑥	Max	-	Vac	480	480	480	480	480	480	480	480	480	480	480	480	480
			Vdc	640	640	640	640	640	640	640	640	640	640	640	640	640
Continuous Torque (Stall) for ΔT winding = 100°C ①②⑦⑧⑨	Nom	T _{CS}	Nm	29.7	30	30	29.4	29.5	42	42	41.6	41.5	53.0	52.5	52.2	
			Ib-in	263	266	266	260	261	372	372	368	367	469	465	426	
Continuous Current (Stall) for ΔT winding = 100°C ①②⑦⑧⑨	Nom	I _{CS}	A _{RMS}	9.3	11.5	13.0	18.7	23.5	12.1	13.6	19.5	24.5	12.9	18.5	26.1	
Continuous Torque (Stall) for ΔT winding = 60°C ②	Nom	T _{CS}	Nm	24	24	24	23.5	23.6	33.6	33.6	33.3	33.2	42.4	42.0	41.8	
			Ib-in	212	212	212	208	209	297	297	295	294	375	372	370	
Max Mechanical Speed ⑤	Nom	N _{max}	rpm	6000	6000	6000	6000	6000	6000	6000	6000	6000	6000	6000	6000	
Peak Torque ①②	Nom	T _p	Nm	79.4	79.5	79.8	78.5	78.4	113	113	111	111	143	142	141	
			Ib-in	704	704	706	695	694	1000	1000	985	982	1269	1253	1250	
Peak Current	Nom	I _p	A _{RMS}	34.5	34.5	39.0	56.1	70.5	36.3	40.8	58.6	73.5	38.7	55.5	78.3	
75 Vdc Rated Torque (speed) ①②⑦⑧⑨⑩		T _{rtd}	Nm	-	-	-	-	-	-	-	-	-	-	-	-	
			Ib-in	-	-	-	-	-	-	-	-	-	-	-	-	-
75 Vdc Rated Speed		N _{rtd}	rpm	-	-	-	-	-	-	-	-	-	-	-	-	
75 Vdc Rated Power (speed) ①②⑦⑧⑨		P _{rtd}	kW	-	-	-	-	-	-	-	-	-	-	-	-	
			Hp	-	-	-	-	-	-	-	-	-	-	-	-	
120 Vac (160 Vdc) Rated Torque (speed) ①②⑦⑧⑨⑩		T _{rtd}	Nm	-	-	-	-	-	-	-	-	-	-	-	-	
			Ib-in	-	-	-	-	-	-	-	-	-	-	-	-	-
120 Vac (160 Vdc) Rated Speed		N _{rtd}	rpm	-	-	-	-	-	-	-	-	-	-	-	-	
120 Vac (160 Vdc) Rated Power (speed) ①②⑦⑧⑨		P _{rtd}	kW	-	-	-	-	-	-	-	-	-	-	-	-	
			Hp	-	-	-	-	-	-	-	-	-	-	-	-	
240 Vac (320 Vdc) Rated Torque (speed) ①②⑦⑧⑨⑩		T _{rtd}	Nm	-	-	-	23.8	23.3	-	-	34.7	33.4	-	-	42.8	
			Ib-in	-	-	-	211	205	-	-	307	296	-	-	379	
240 Vac (320 Vdc) Rated Speed		N _{rtd}	rpm	-	-	-	1800	2000	-	-	1300	1500	-	-	1200	
240 Vac (320 Vdc) Rated Power (speed) ①②⑦⑧⑨		P _{rtd}	kW	-	-	-	4.49	4.86	-	-	4.72	5.25	-	-	5.38	
			Hp	-	-	-	6.01	6.52	-	-	6.33	7.04	-	-	7.21	
400 Vac (560 Vdc) Rated Torque (speed) ①②⑦⑧⑨⑩		T _{rtd}	Nm	25.3	25.3	23.6	20.1	16.3	34.4	33.8	28.5	25.2	43.5	39.6	31.5	
			Ib-in	224	224	209	178	144	304	299	252	223	385	350	279	
400 Vac (560 Vdc) Rated Speed		N _{rtd}	rpm	1500	1500	2000	3000	4000	1400	1500	2400	3000	1200	1800	2500	
400 Vac (560 Vdc) Rated Power (speed) ①②⑦⑧⑨		P _{rtd}	kW	3.97	3.97	4.94	6.31	6.83	5.04	5.31	7.16	7.92	5.47	7.46	8.25	
			Hp	5.32	5.32	6.62	8.46	9.16	6.76	7.12	9.60	10.6	7.33	10.0	11.1	
480 Vac (640 Vdc) Rated Torque (speed) ①②⑦⑧⑨⑩		T _{rtd}	Nm	24.3	24.3	22.1	18.2	14.1	33.8	32.1	26.3	22.0	41.5	35.9	27.3	
			Ib-in	215	215	196	161	125	299	284	233	195	367	318	242	
480 Vac (640 Vdc) Rated Speed		N _{rtd}	rpm	1800	1800	2500	3500	4500	1500	1800	2800	3500	1400	2000	3000	
480 Vac (640 Vdc) Rated Power (speed) ①②⑦⑧⑨		P _{rtd}	kW	4.58	4.58	5.79	6.67	6.65	5.31	6.05	7.71	8.07	6.08	7.52	8.58	
			Hp	6.14	6.14	7.76	8.94	8.91	7.12	8.11	10.3	10.8	8.16	10.1	11.5	

See following page for notes.

AKM7x Performance Data – Up to 480 Vac (640 Vdc Bus) voltage (Continued)

Parameters	Tol	Symbol	Units	AKM72					AKM73				AKM74		
				K	L	M	P	Q	L	M	P	Q	L	P	Q
Torque Constant ①	±10%	K_t	Nm/A _{rms}	3.2	2.6	2.31	1.58	1.3	3.5	3.09	2.13	1.7	4.14	2.84	2.0
			lb-in/A _{rms}	28.3	23.0	20.5	14.0	11.5	31.0	27.4	18.9	15	36.6	25.1	17.7
Back EMF Constant ⑥	±10%	K_e	V _{rms} /krpm	208	169	149.8	102	81.2	225	199.8	137	109	266	183	129
Motor Constant	Nom	K_m	N-m/√W	2.261	2.21	2.290	2.18	2.08	2.93	2.903	2.82	2.67	3.51	3.38	3.27
			lb-in/√W	20.02	19.6	20.25	19.3	18.4	25.9	25.66	25.0	23.6	31.0	29.9	28.9
Resistance (line-line) ⑥	±10%	R_m	ohm	1.36	0.92	0.69	0.35	0.26	0.95	0.76	0.38	0.25	0.93	0.47	0.25
Inductance (line-line)		L	mH	20.7	13.6	10.8	5.0	3.2	15.7	12.4	5.9	3.7	16.4	7.7	3.8
Inertia (includes Resolver feedback) ③	±10%	J_m	kg-cm ²	65					92				120		
			lb-in-s ²	0.057					0.082				0.11		
Optional Brake Inertia (additional)	±10%	J_m	kg-cm ²	1.589					1.589				1.589		
			lb-in-s ²	1.41E-03					1.41E-03				1.41E-03		
Weight (w/o brake) ⑩		W	kg	19.7					26.7				33.6		
			lb	43.4					58.8				74.0		
Static Friction ⑩⑩		T_f	Nm	0.16					0.24				0.33		
			lb-in	1.4					2.1				2.9		
Viscous Damping ①		K_{dv}	Nm/krpm	0.06					0.13				0.2		
			lb-in/krpm	0.5					1.2				1.8		
Thermal Time Constant		TCT	minutes	46					53				60		
Thermal Resistance		R_{thw-a}	°C/W	0.39					0.33				0.30		
Operating Ambient Temperature Range ⑭ ⑮ ⑯			°C	-20 to 40					-20 to 40				-20 to 40		
Pole Pairs				5					5				5		
Heat Sink Size				18"x18"x1/2" Aluminum Plate					18"x18"x1/2" Aluminum Plate				18"x18"x1/2" Aluminum Plate		

Notes:

- ① Motor winding temperature rise, ΔT=100°C, at 40°C ambient.
- ② All data referenced to sinusoidal commutation.
- ③ Add parking brake if applicable for total inertia.
- ④ Motor with standard heat sink.
- ⑤ May be limited at some values of V_{bus}.
- ⑥ Measured at 25°C.
- ⑦ Brake option reduces continuous torque ratings by 1 Nm.
- ⑧ Non-Resolver feedback options reduce continuous torque ratings by:
AKM72 = 2.0 Nm AKM73 = 2.7 Nm AKM74 = 3.4 Nm
- ⑨ Motors with non-resolver feedback and brake option, reduce continuous torque by:
AKM72 = 3.9 Nm AKM73 = 5.1 Nm AKM74 = 6.2 Nm
- ⑩ For motors with optional shaft seal, reduce torque shown by 0.25 Nm (2.21 lb-in), and increase T_f by the same amount.
- ⑪ Brake option increases weight by 3.1 kg (6.82 lb).
- ⑫ Motors can be operated up to 480 Vac. For performances curves at voltages, listed or unlisted, please use our online [Performance Curve Generator Tool](#).
- ⑬ Brake option will operate in this range in a non-condensing environment. See page 55 for more information.
- ⑭ "AA" or "AB" BiSS feedback lower limit is -15°C; all other feedbacks meet or exceed this range.
- ⑮ Operation outside of this range may be possible. Please contact Kollmorgen Customer Support with your application requirements.

Additional Notes:

See system data beginning on page 14 for typical torque/speed performance.

Additional windings may exist. Please contact Kollmorgen Customer Support for further information or to request custom winding options for your application requirements.

*Complete AKM series model nomenclature can be found on pages 10-12.

AKM[®] Servo Motor Specifications

AKM7x Frame Dimensional Drawings

AKM 2D/3D CAD models can be found here: [AKM CAD Models](#)

C- connector option

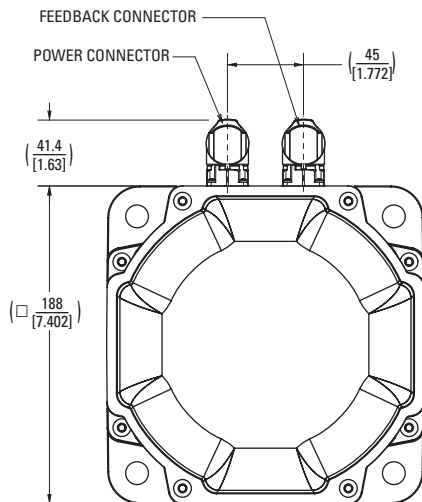
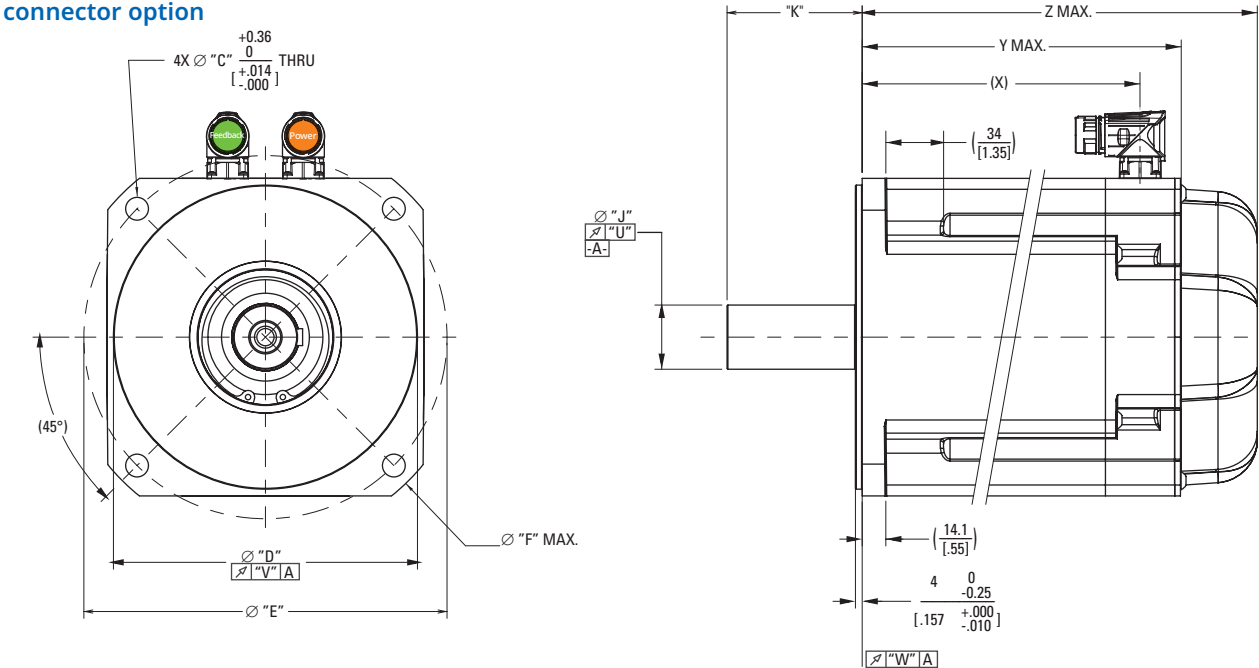

G- connector option

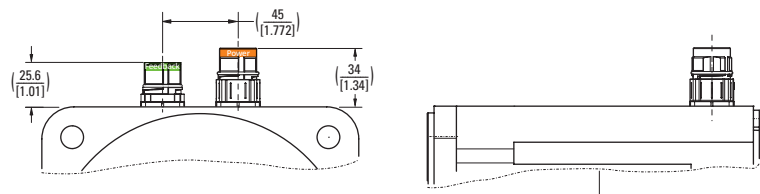

H- connector option

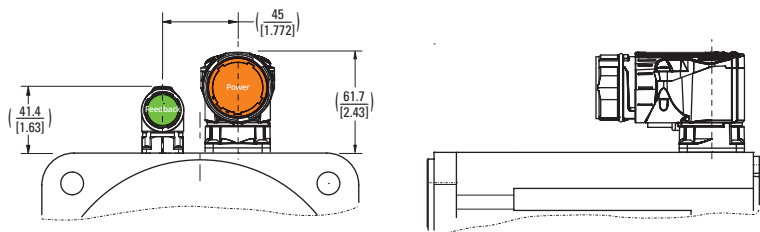

Shaft-keyway dimensions

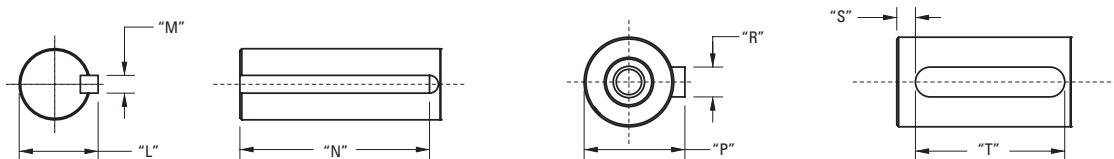

Dimensional data tables for callouts are located on the following page.

AKM7x Mounting Flange-Shaft Dimensional Data

Mounting Flange-Shaft	Hole Diameter "C"	Pilot Diameter "D"	Bolt Circle Dia. "E"	"F"	"H"	Shaft Diameter "J"	Shaft Length "K"	Shaft Dia. w/ Key "L"
AC	13.50 [0.531]	180 [7.0866]	215.00 [8.465]	-	D M12 DIN 332	38 [1.496]	80 [3.15]	-
AN	13.50 [0.531]	180 [7.0866]	215.00 [8.465]	-	D M12 DIN 332	38 [1.496]	80 [3.15]	-
GC	13.50 [0.531]	180 [7.0866]	215.00 [8.465]	-	D M12 DIN 332	32 [1.5298]	58.5 [2.30]	-
GN	13.50 [0.531]	180 [7.0866]	215.00 [8.465]	-	D M12 DIN 332	32 [1.5298]	58.5 [2.30]	-
KK	13.50 [0.531]	114.3 [4.5000]	200 [7.874]	225 [8.858]	-	35 [1.3779]	79 [3.11]	38 [1.496]

Mounting Flange-Shaft	Key Width "M"	Key Length "N"	Shaft Dia. w/ Key "P"	Key Width "R"	"S"	Key Length "T"	"U"	"V"	"W"
AC	-	-	41 [1.614]	10 [0.3937]	5.00 [0.197]	70 [2.756]	0.050 [0.0019]	0.100 [0.0039]	0.100 [0.0039]
AN	-	-	-	-	-	-	0.050 [0.0019]	0.100 [0.0039]	0.100 [0.0039]
GC	-	-	35 [1.378]	108 [0.3937]	4 [0.157]	50 [1.969]	0.050 [0.0019]	0.100 [0.0039]	0.100 [0.0039]
GN	-	-	-	-	-	-	0.050 [0.0019]	0.100 [0.0039]	0.100 [0.0039]
KK	10 [0.3937]	70 [2.756]	-	-	-	-	0.050 [0.0019]	0.100 [0.0039]	0.100 [0.0039]

AKM7x Motor Length Dimensional Data

	No Brake (N)		
	X	Y MAX	Z MAX
	C-, G-, H-	C-, G-, H-	C-, G-, H-
Connector	C-, G-, H-	C-, G-, H-	C-, G-, H-
Feedback Option	R-, C-, CA, 1-, 2-, Ex, Ax, Dx, Lx, Gx	R-, C-, CA-, 1-, 2-, Ex	Ax, Dx, Lx, Gx
AKM72	164.5 [6.48]	192.5 [7.58]	201.7 [7.94]
AKM73	198.5 [7.81]	226.5 [8.92]	235.7 [9.28]
AKM74	232.5 [9.15]	260.5 [10.26]	269.7 [10.62]

	Brake (2)		
	X	Z MAX	
	C-, G-, H-	C-, G-, H-	C-, G-, H-
Connector	C-, G-, H-	C-, G-, H-	C-, G-, H-
Feedback Option	R-, C-, CA, 1-, 2-, Ex, Ax, Dx, Lx, Gx	R-, C-, CA-, 1-, 2-, Ex	Ax, Dx, Lx, Gx
AKM72	164.5 [6.48]	234.5 [9.23]	253.3 [9.97]
AKM73	198.5 [7.81]	268.5 [10.57]	287.3 [11.31]
AKM74	232.5 [9.15]	302.5 [11.91]	321.3 [12.65]

Note 1: Dimensions are in mm [inches].

Note 2: Detailed Connector and Feedback option information can be found on pages 11-12.

Note 3: Product designed in metric. English conversions provided for reference only.

*Complete AKM series model nomenclature can be found on pages 10-12.

AKM[®] Servo Motor Specifications

AKM8x Performance Data – Up to 480 Vac (640 Vdc Bus) voltage

				AKM82	AKM83	AKM84
Parameters	Tol	Symbol	Units	AKM82T	AKM83T	AKM84T
Max Rated Voltage ⑩	Max	-	Vac	480	480	480
			Vdc	640	640	640
Continuous Torque (Stall) for ΔT winding = 100°C ①②⑦⑧⑨	Nom	T _{CS}	Nm	75	130	180
			lb-in	664	1151	1593
Continuous Current (Stall) for ΔT winding = 100°C ①②⑦⑧⑨	Nom	I _{CS}	A _{RMS}	48	62	67
Continuous Torque (Stall) for ΔT winding = 60°C ②	Nom	T _{CS}	Nm	58.1	100	140
			lb-in	514	885	1239
Max Mechanical Speed ⑤	Nom	N _{max}	rpm	3000	3000	3000
Peak Torque ①②	Nom	T _p	Nm	210	456	668
			lb-in	1859	4036	5912
Peak Current	Nom	I _p	A _{RMS}	240	310	335
75 Vdc Rated Torque (speed) ①②⑦⑧⑨⑩		T _{Rtd}	Nm	-	-	-
			lb-in	-	-	-
Rated Speed		N _{Rtd}	rpm	-	-	-
Rated Power (speed) ①②⑦⑧⑨		P _{Rtd}	kW	-	-	-
			Hp	-	-	-
120 Vac (160 Vdc) Rated Torque (speed) ①②⑦⑧⑨⑩		T _{Rtd}	Nm	-	-	-
			lb-in	-	-	-
Rated Speed		N _{Rtd}	rpm	-	-	-
Rated Power (speed) ①②⑦⑧⑨		P _{Rtd}	kW	-	-	-
			Hp	-	-	-
240 Vac (320 Vdc) Rated Torque (speed) ①②⑦⑧⑨⑩		T _{Rtd}	Nm	-	-	-
			lb-in	-	-	-
Rated Speed		N _{Rtd}	rpm	-	-	-
Rated Power (speed) ①②⑦⑧⑨		P _{Rtd}	kW	-	-	-
			Hp	-	-	-
400 Vac (560 Vdc) Rated Torque (speed) ①②⑦⑧⑨⑩		T _{Rtd}	Nm	47.5	70	105
			lb-in	420	620	929
Rated Speed		N _{Rtd}	rpm	2500	2200	1800
Rated Power (speed) ①②⑦⑧⑨		P _{Rtd}	kW	12.4	16.1	19.8
			Hp	16.65	21.62	26.58
480 Vac (640 Vdc) Rated Torque (speed) ①②⑦⑧⑨⑩		T _{Rtd}	Nm	38	60	93
			lb-in	336	531	823
Rated Speed		N _{Rtd}	rpm	3000	2500	2000
Rated Power (speed) ①②⑦⑧⑨		P _{Rtd}	kW	11.9	15.7	19.5
			Hp	16.0	21.0	26.1

See following page for notes.

AKM8x Performance Data – Up to 480 Vac (640 Vdc Bus) voltage (Continued)

Parameters	Tol	Symbol	Units	AKM82	AKM83	AKM84
				AKM82T	AKM83T	AKM84T
Torque Constant ①	±10%	K _t	Nm/A _{rms}	1.6	2.1	2.7
			lb-in/A _{rms}	14	19	23.8
Back EMF Constant ⑥	±10%	K _e	V _{rms} /krpm	108	140	177
Motor Constant	Nom	K _m	N-m/√W	4.31	6.94	9.15
			lb-in/√W	38.1	61.4	81.0
Resistance (line-line) ⑥	±10%	R _m	ohm	0.092	0.061	0.058
Inductance (line-line)		L	mH	2.73	2.36	2.5
Inertia (includes Resolver feedback) ③		J _m	kg-cm ²	172	334	495
			lb-in-s ²	0.15	0.29	0.43
Optional Brake Inertia (additional)		J _m	kg-cm ²	4.438	4.438	4.438
			lb-in-s ²	3.930E-03	3.930E-03	3.93E-03
Weight (w/o brake) ⑧		W	kg	49	73	97
			lb	107.8	160.6	213.4
Static Friction ①⑩		T _f	Nm	1.7	1.83	2.34
			lb-in	15.05	16.20	20.71
Viscous Damping ①		K _{dv}	Nm/krpm	0.35	0.95	1.6
			lb-in/krpm	3.10	8.41	14.16
Thermal Time Constant		TCT	minutes	71	94	116
Thermal Resistance		R _{thw-a}	°C/W	0.225	0.203	0.183
Operating Ambient Temperature Range ⑩ ⑪ ⑫			°C	-20 to 40	-20 to 40	-20 to 40
Pole Pairs				5	5	5
Heat Sink Size				18"x18"x1/2" Aluminum Plate	18"x18"x1/2" Aluminum Plate	18"x18"x1/2" Aluminum Plate

Notes:

- ① Motor winding temperature rise, ΔT = 100° C, at 40° C ambient.
- ② All data referenced to sinusoidal commutation.
- ③ Add parking brake if applicable for total inertia.
- ④ Motor with standard heat sink.
- ⑤ May be limited at some values of V_{bus}.
- ⑥ Measured at 25° C.
- ⑦ Brake option decreases continuous torque by 6 Nm
- ⑧ Brake option increases weight by 8.1 kg (17.8 lb).
- ⑨ Non-Resolver feedback options reduce continuous torque ratings by:
AKM82 = 9 Nm, AKM83 = 6 Nm, AKM84 = 18 Nm
- ⑩ Motor with non-resolver feedback and brake options reduce continuous torque ratings by:
AKM82 = 17 Nm, AKM83 = 16 Nm, AKM84 = 28 Nm
- ⑪ Motors can be operated up to 480 Vac. For performances curves at voltages, listed or unlisted, please contact Kollmorgen Customer Support.
- ⑫ Brake option will operate in this range in a non-condensing environment. See page 55 for more information.
- ⑬ "AA" or "AB" BiSS feedback lower limit is -15°C; all other feedbacks meet or exceed this range.
- ⑭ Operation ABOVE 40°C may be possible. Please contact Kollmorgen Customer Support with your application requirements.

Additional Notes:

See system data beginning on page 14 for typical torque/speed performance.

Additional windings may exist. Please contact Kollmorgen Customer Support for further information or to request custom winding options for your application requirements.

*Complete AKM series model nomenclature can be found on pages 10-12.

AKM[®] Servo Motor Specifications

AKM8x Frame with Terminal Box Dimensional Drawings

AKM 2D/3D CAD models can be found here: [AKM CAD Models](#)

T-connector option

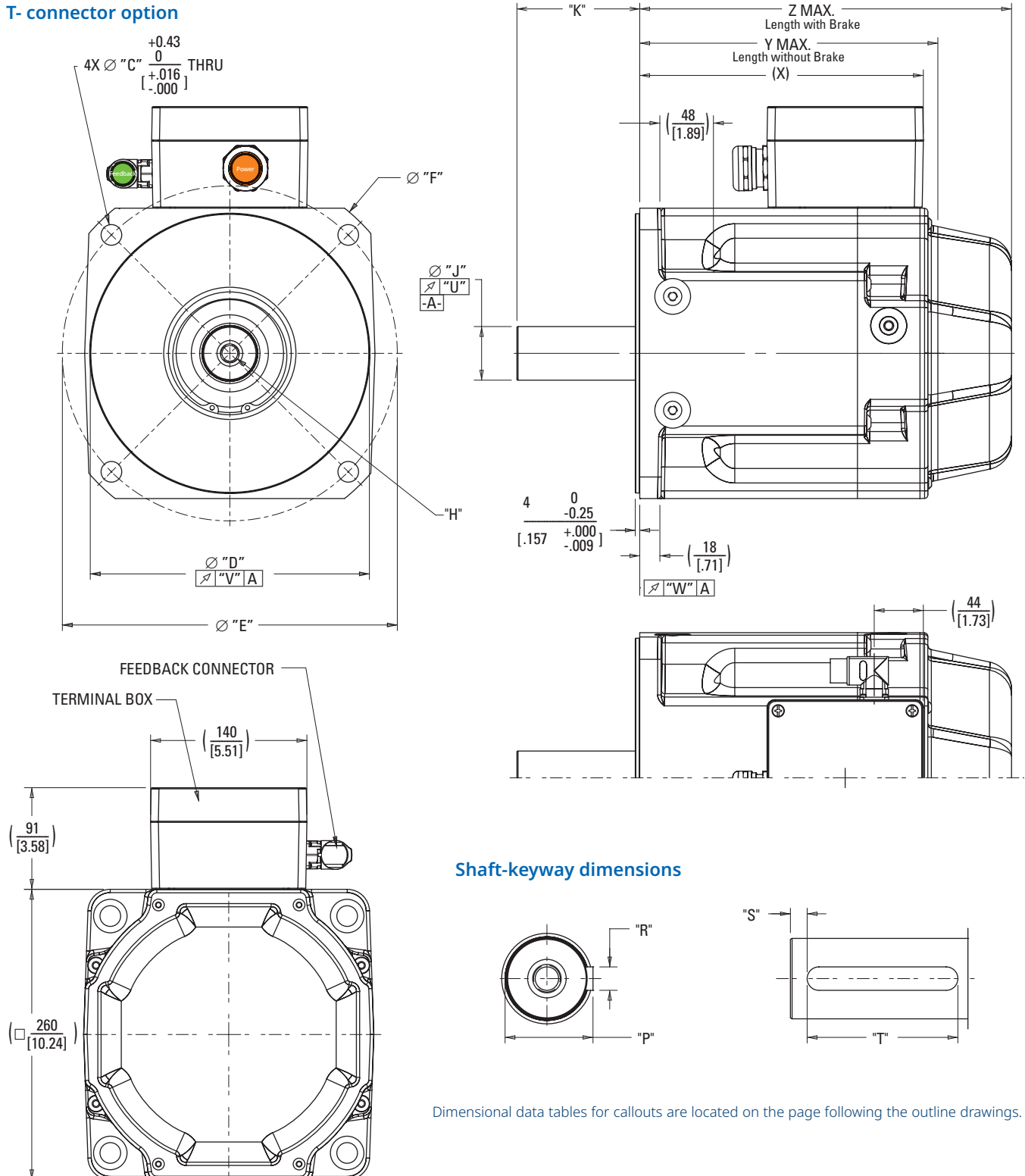

Dimensional data tables for callouts are located on the page following the outline drawings.

AKM82 Frame with Rotatable IP65 Connectors Dimensional Drawings

AKM 2D/3D CAD models can be found here: [AKM CAD Models](#)

H- connector option

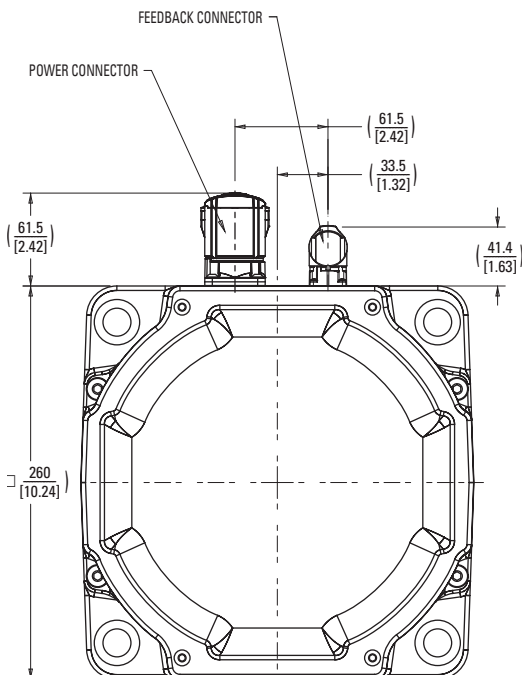
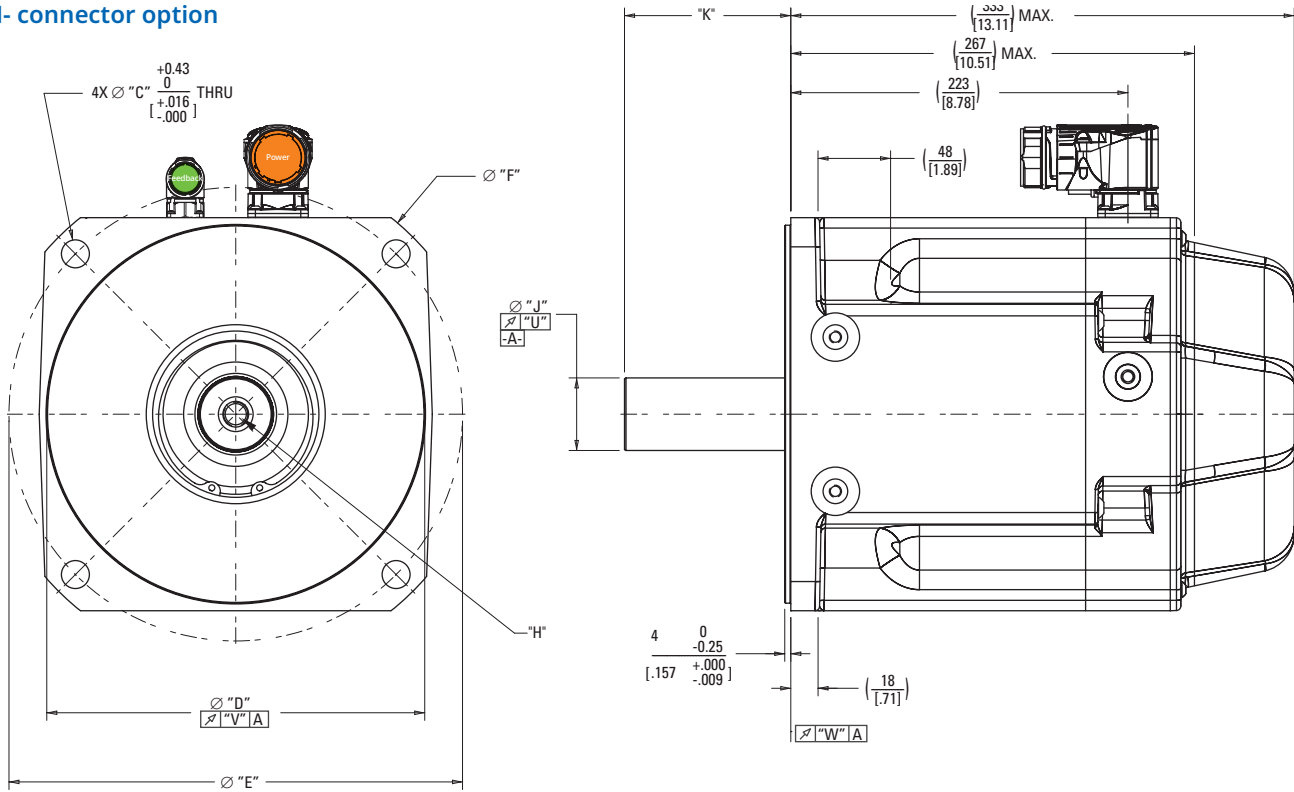

Shaft-keyway dimensions

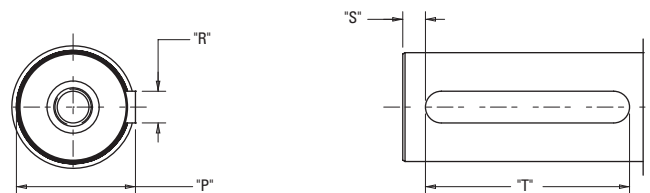

Dimensional data tables for callouts are located on the page following the outline drawings.

*Complete AKM series model nomenclature can be found on pages 10-12.

AKM[®] Servo Motor Specifications

AKM8x Mounting Flange-Shaft Dimensional Data

Mounting Flange-Shaft	Hole Diameter "C"	Pilot Diameter "D"	Bolt Circle Dia. "E"	"F"	"H"	Shaft Diameter "J"	Shaft Length "K"
AC	18.5 [0.728]	250 [9.8425]	300 [11.811]	-	D M16 DIN 332	48 [1.8898]	110 [4.33]
AN	18.5 [0.728]	250 [9.8425]	300 [11.811]	-	D M16 DIN 332	48 [1.8898]	110 [4.33]
CC	14.5 [0.571]	230 [9.055]	265 [10.433]	300 [11.811]	D M16 DIN 332	48 [1.8898]	110 [4.33]
CN	14.5 [0.571]	230 [9.055]	265 [10.433]	300 [11.811]	D M16 DIN 332	48 [1.8898]	82 [3.228]
HC	14.5 [0.571]	230 [9.055]	265 [10.433]	300 [11.811]	D M16 DIN 332	42 [1.6535]	82 [3.228]
HN	14.5 [0.571]	230 [9.055]	265 [10.433]	300 [11.811]	D M16 DIN 332	42 [1.6535]	82 [3.228]
GC	18.5 [0.728]	250 [9.8425]	300 [11.811]	-	D M16 DIN 332	48 [1.8898]	82 [3.228]
GN	18.5 [0.728]	250 [9.8425]	300 [11.811]	-	D M16 DIN 332	48 [1.8898]	82 [3.228]
MC	18.5 [0.728]	250 [9.8425]	300 [11.811]	-	D M16 DIN 332	48 [1.8898]	110 [4.33]
MN	18.5 [0.728]	250 [9.8425]	300 [11.811]	-	D M16 DIN 332	48 [1.8898]	110 [4.33]
TC	14.5 [0.571]	230 [9.055]	265 [10.433]	300 [11.811]	D M16 DIN 332	48 [1.8898]	110 [4.33]
TN	14.5 [0.571]	230 [9.055]	265 [10.433]	300 [11.811]	D M16 DIN 332	48 [1.8898]	110 [4.33]

REINFORCED BEARINGS

Mounting Flange-Shaft	Shaft Dia. w/ Key "P"	Key Width "R"	"S"	Key Length "T"	"U"	"V"	"W"
AC	51.5 [2.028]	14 [0.5512]	10 [0.394]	90 [3.543]	0.050 [0.0019]	0.125 [0.0049]	0.125 [0.0049]
AN	-	-	-	-	0.050 [0.0019]	0.125 [0.0049]	0.125 [0.0049]
CC	51.5 [2.028]	14 [0.5512]	10 [0.394]	90 [3.543]	0.050 [0.0019]	0.100 [0.0039]	0.100 [0.0039]
CN	-	-	-	-	0.050 [0.0019]	0.100 [0.0039]	0.100 [0.0039]
HC	45 [1.7772]	12 [0.5512]	8 [0.315]	63 [2.480]	0.050 [0.0019]	0.100 [0.0039]	0.100 [0.0039]
HN	-	-	-	-	0.050 [0.0019]	0.100 [0.0039]	0.100 [0.0039]
GC	51.5 [2.028]	14 [0.5512]	8 [0.315]	63 [2.480]	0.050 [0.0019]	0.125 [0.0049]	0.125 [0.0049]
GN	-	-	-	-	0.050 [0.0019]	0.125 [0.0049]	0.125 [0.0049]
MC	51.5 [2.028]	14 [0.5512]	10 [0.394]	90 [3.543]	0.050 [0.0019]	0.125 [0.0049]	0.125 [0.0049]
MN	-	-	-	-	0.050 [0.0019]	0.125 [0.0049]	0.125 [0.0049]
TC	51.5 [2.028]	14 [0.5512]	10 [0.394]	90 [3.543]	0.050 [0.0019]	0.100 [0.0039]	0.100 [0.0039]
TN	-	-	-	-	0.050 [0.0019]	0.100 [0.0039]	0.100 [0.0039]

REINFORCED BEARINGS

AKM8x Motor Length Dimensional Data

Connector	No Brake (N)		Brake (2)
	X	Y MAX	Z MAX
Feedback Option	H-, T-	H-, T-	H-, T-
AKM82 "H" Connector	223 [8.78]	267 [10.51]	333 [13.11]
AKM82 "T" TERMINAL BOX	255 [10.04]	267 [10.51]	333 [13.11]
AKM83 "T" TERMINAL BOX	335.5 [13.21]	347.5 [13.68]	413.5 [16.28]
AKM84 "T" TERMINAL BOX	416 [16.38]	428 [16.85]	494 [19.45]

Note 1: Dimensions are in mm [inches].

Note 2: Detailed Connector and Feedback option information can be found on pages 11-12.

Note 3: Product designed in metric. English conversions provided for reference only.

Brake Option

Failsafe, Holding Brake

The holding brake is designed to provide static holding torque to the motor shaft with the brake coil de-energized. The brake must first be released (coil energized) prior to commanding motor rotation as determined by its drop-out time. The brake is intended for holding or “parking” of a stationary motor. It is not intended for dynamic braking. There should be absolutely no motion of the rotor when power is removed from the brake coil.

AKM Motor Brake Specifications

Motor Family	Minimum Static Torque @120°C		Weight		Power Consumption @24V, 20°C	Current @24V, 20°C	Inertia		Closing Time (engage)	Opening Time (release)	Backlash	
	Nm	lb-in	Kg	lb	Watts ±7%	ADC	kg-cm ²	lb-in-sec ²			msec	msec
AKM1	0.41	3.63	0.19	0.42	6.3	0.27	0.0013	0.12E-05	22	45	1.15	0.53
AKM2	1.42	12.6	0.27	0.59	8.4	0.35	0.013	1.2E-05	36	45	1.01	0.46
AKM3	2.5	22.1	0.36	0.79	10.2	0.42	0.014	1.2E-05	20	50	1.01	0.46
AKM4	5.3	46.9	0.69	1.52	12.7	0.53	0.058	5.12E-05	30	75	0.81	0.37
AKM5	14.5	128	1.2	2.64	19.7	0.81	0.166	1.47E-04	30	115	0.71	0.31
AKM6	25	221	2.2	4.81	25.7	1.07	0.668	5.91E-04	40	155	0.51	0.24
AKM7	53	469	3.1	6.82	35.6	1.48	1.589	1.41E-03	70	170	0.44	0.20
AKM8	150	1330	8.1	17.8	52.3	2.04	4.438	3.93E-03	100	300	0.44	0.20

Note 1: Contamination of the motor internal compartment by oil or other foreign materials will result in failure of the brake. Check the suitability of motor sealing for the working environment.

Note 2: Operating Voltage: 24 Vdc ± 10%.

Note 3: Maximum backlash is calculated using worst-case tolerancing, and typical backlash is calculated using statistical tolerancing.

Note 4: Brake Operating Temperature Range: -20C to 120C. Sub-zero temperatures present a freezing risk for condensation which could prevent correct brake operation.

L10 Bearing Fatigue and Shaft Loading

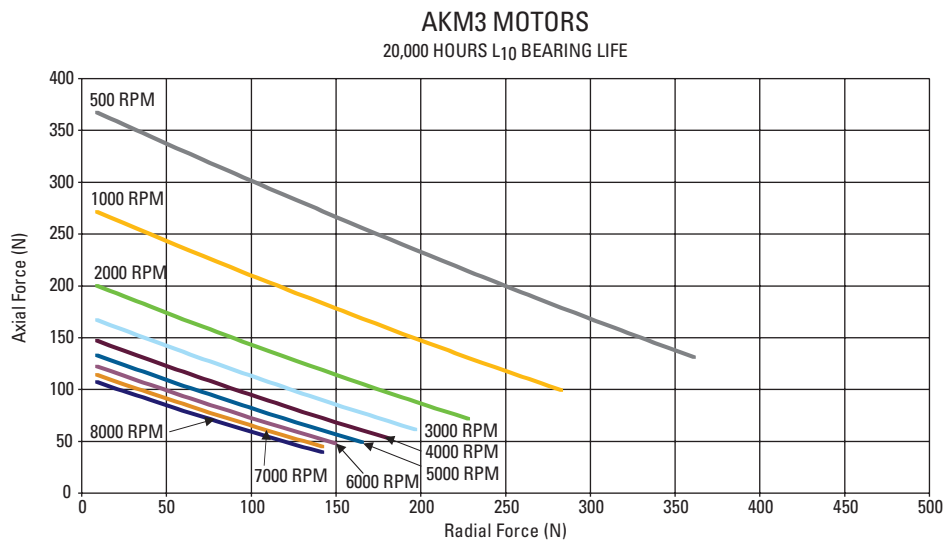
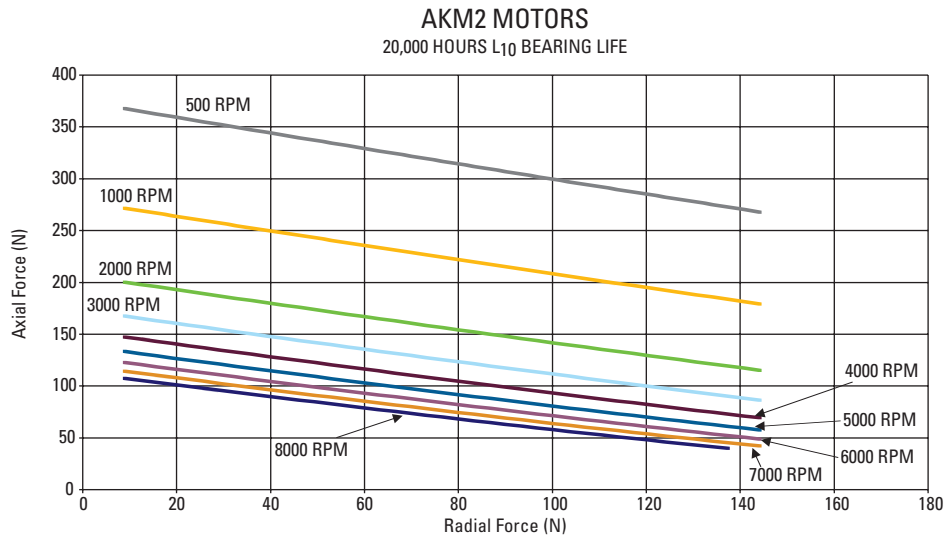
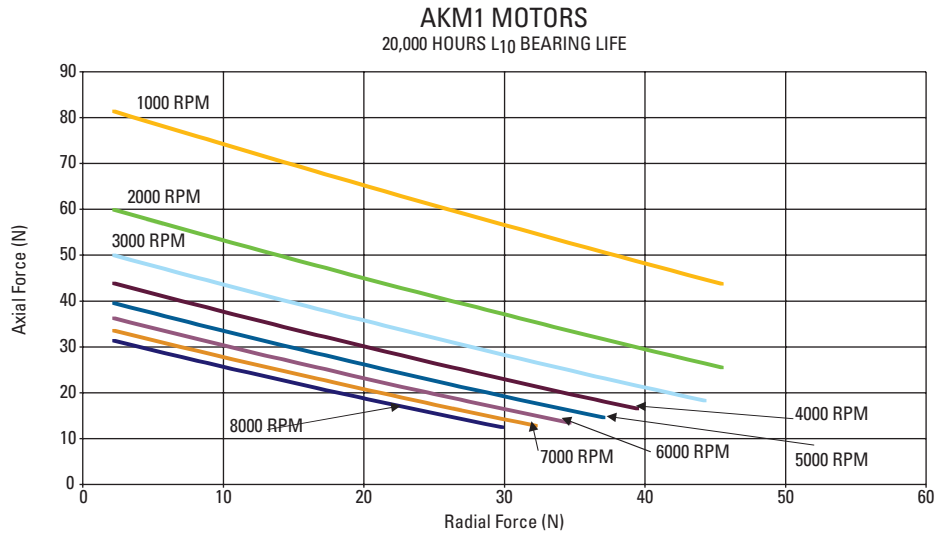

AKM4 MOTORS
20,000 HOURS L₁₀ BEARING LIFE

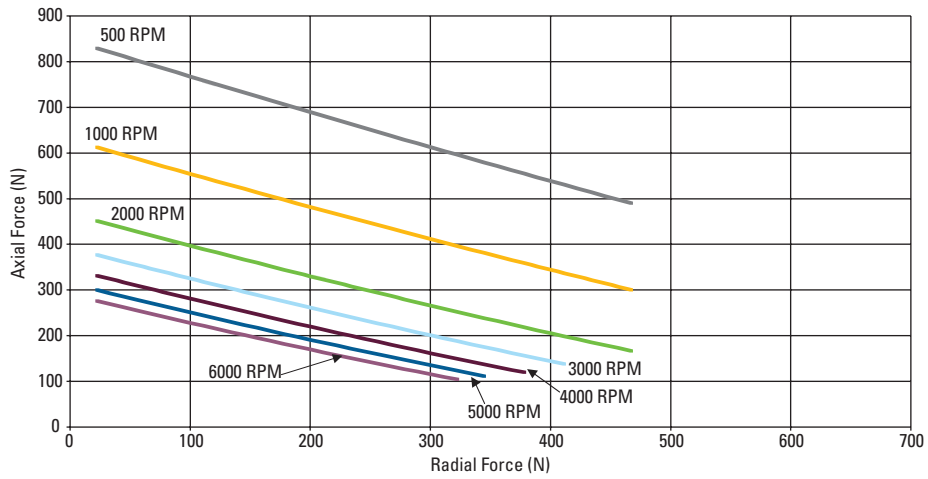

AKM5 MOTORS
20,000 HOURS L₁₀ BEARING LIFE

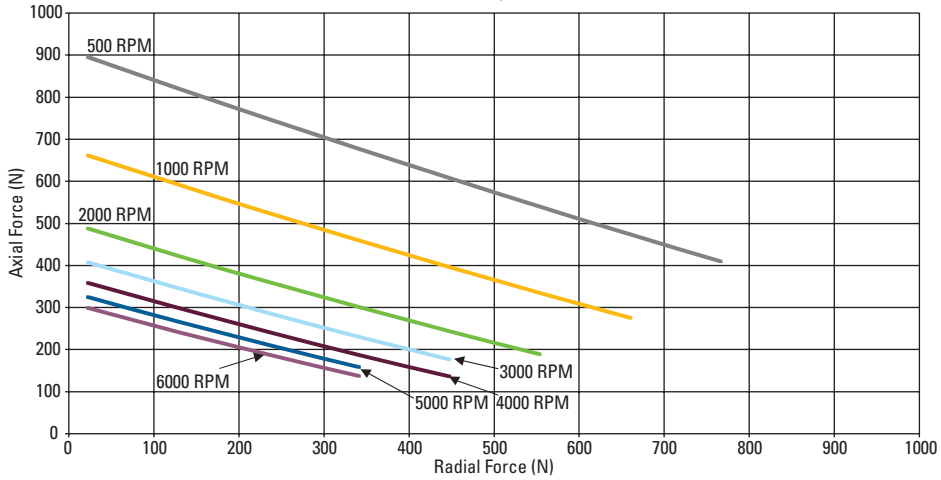

AKM6 MOTORS
20,000 HOURS L₁₀ BEARING LIFE

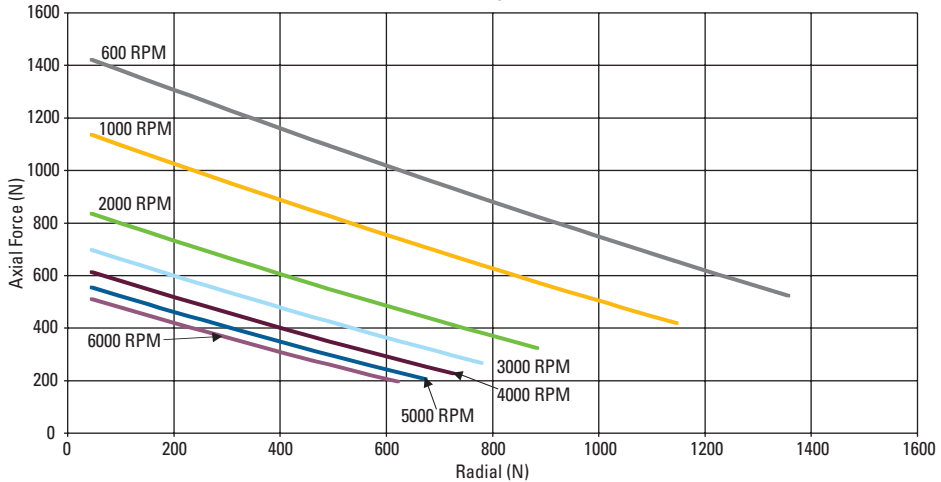

L10 Bearing Fatigue and Shaft Loading

AKM7 MOTORS

20,000 HOURS L₁₀ BEARING LIFE

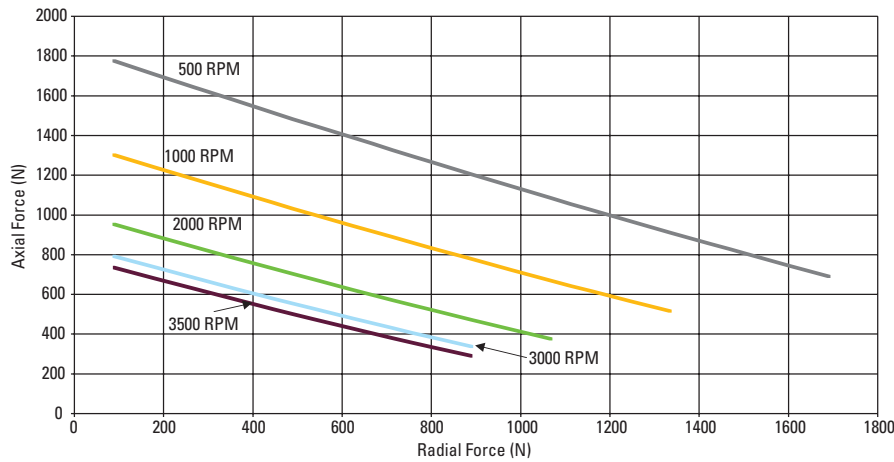

AKM8 MOTORS

20,000 HOURS L₁₀ BEARING LIFE

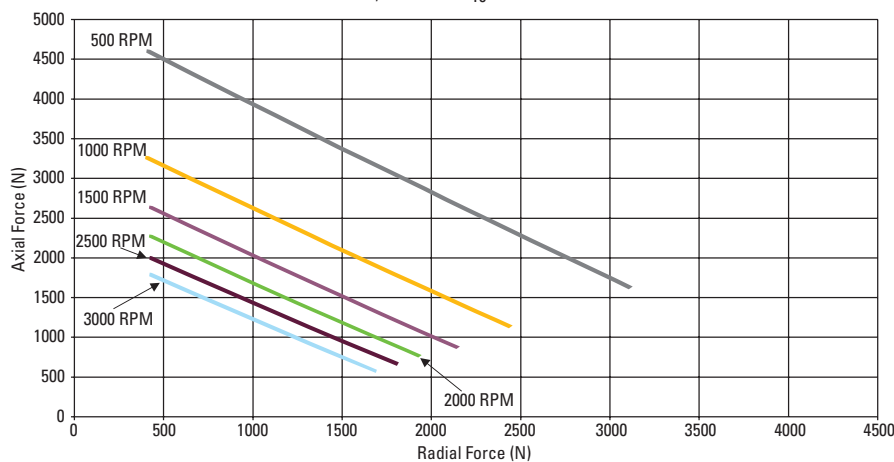

AKM83 & 84 MOTOR WITH REINFORCED BEARING

20,000 HOURS L₁₀ BEARING LIFE

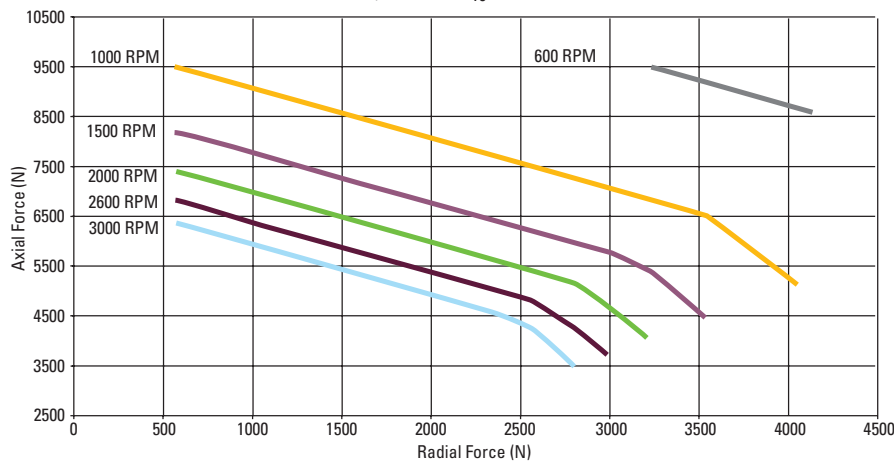

Shaft Loading

Motor	Max. Radial Force (N)	Max. Axial Force (N)
AKM1	48	200
AKM2	150	600
AKM3	340	600
AKM4	500	1400
AKM5	830	1740
AKM6	1940	2200
AKM7	2300	3000
AKM8	2752	4750

The maximum radial load ratings reflect the following assumptions:

1. Motors are operated with peak torque of the longest member of the frame size.
2. Fully reversed load applied to the end of the smallest diameter standard mounting shaft extension. Excluding AKM4X-EK which is rated at 240 N max. radial force.
3. Infinite life with 99% reliability.
4. Safety factor = 2.

Teflon Shaft Seals

There is a normal break-in period for our Teflon® shaft seals. Best conditions during the break-in period would be at the operational temperature and speed that would be typical for the application.

During the break-in period, some “shedding” of Teflon material is normal. The debris is not a sign of seal deterioration or failure. The material “shed” should be reduced with usage.

Typically, a few hours at operational speed is enough to break-in the shaft seal.

Thermal Sensor Protective Devices

The standard version of each motor is fitted with an electrically isolated PTC Avalanche-Type thermal sensor or PT1000 RTD Linear thermal sensor, depending on connector (see Connector Option table on p. 11). The thermal sensors do not provide any protection against short, heavy overloading.

The motor can be delivered with a PT1000 or KTY84/130 equivalent sensor optionally for certain connectors (see Thermal Sensor options 1 and 2). Please consult Kollmorgen Customer Support for optional thermal device requests based on motor configuration.

With digital feedback systems SFD (C), SFD3 (CA) and Hiperface DSL (GE/GF), the temperature sensor status is transmitted digitally and evaluated in the drive.

Provided that our configured feedback cables are used, the sensor is integrated into the monitoring system of the digital servo amplifiers.

Thermal Device Options: Resistance vs. Temperature Graphs

Kollmorgen AKD drives can directly interpret information from the motor thermal sensors to properly reflect the motor winding temperature. For other drives please refer to the graph Delta Between Motor Winding and Thermal Device on the following page.

Standard

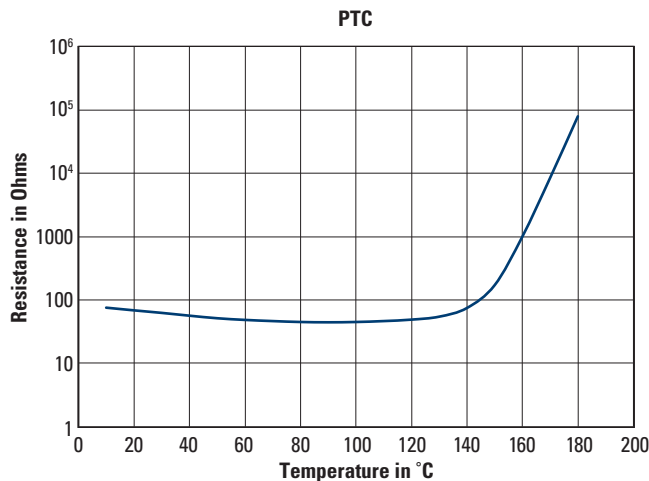

Option 1

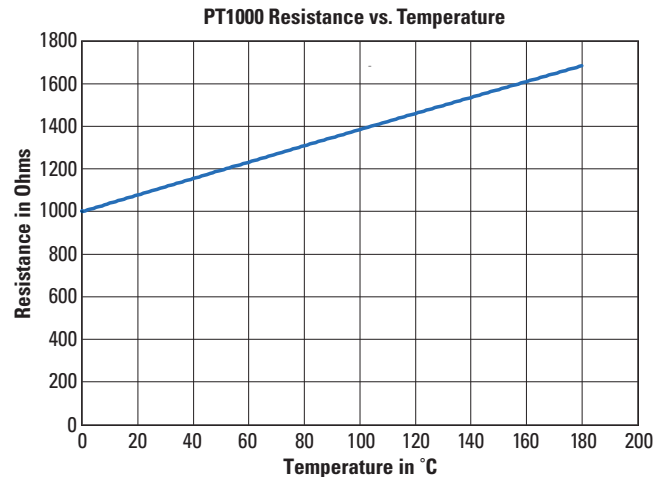

Option 2

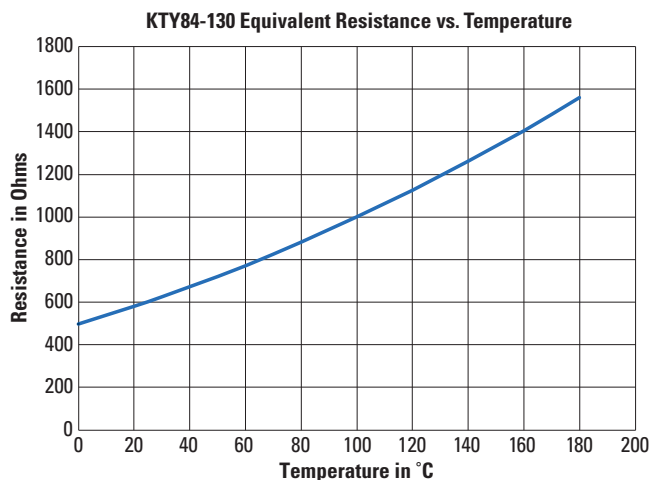

Note 1: PTC thermistor (155°C ± 5°C switching temperature) installed.

Resistance at 25°C: ≤550 ohms.

Switching Resistance: ≥1330 ohms within ±5°C of switch temperature.

Note 2: Optional KTY84-130 Nominal Resistance at 25°C, 603 ohms.

Feedback Options

Phasing Diagram - All Motors

General notes:

- When motor is rotated CW (viewed from drive shaft end), these waveforms result:
 - Voltage U, leads V, leads W.
 - Voltage U-W leads Voltage V-W by 60° electrical.
- When optional shaft seal is included on front shaft extension, note that static friction stated in catalog or on winding data sheet is measured without shaft seal installed.
- Standard outline drawings showing mounting dimensions and standard winding information are available on our website or by calling the Kollmorgen Customer Support at 1-540-633-3545, or through email at support@kollmorgen.com.

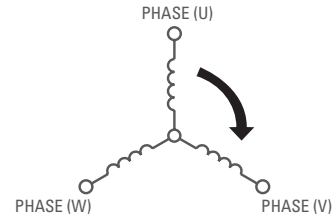

Motor Winding Configuration

Feedback Unit Options				Feedback Resolution			Data Channel Resolution			
Code	AKM Frame Size	Designation	Single-Turn or Multi-Turn	Device Resolution (Sin/Cos per Rev., Bits or Lines/Rev.)	Max. Resolution after AKD Interpolation	Max. Resolution after AKD2G Interpolation	Accuracy (± arc-mins)	Position Values/Rev.	# of Absolute Revs.	
R-	1	Resolver	Single-Turn	1 pole pair (16-Bits)	16-Bits	16-Bits	15	16-Bits	1	
	2-4						10			
	5-8						9			
1-	1-8	Comcoder	Single-Turn	1024 Lines	4,096	4,096	1	Not Absolute	Not Absolute	
2-				2048 Lines	8,192	8,192				
ED				500 Lines	2,000	2,000				
EE				1000 Lines	4,000	4,000				
EF				2000 Lines	8,000	8,000				
EG				2500 Lines	10,000	10,000				
EH				5000 Lines	20,000	20,000				
EJ				10000 Lines	40,000	40,000				
EM				4096 Lines	16,384	16,384				
EN				8192 Lines	32,768	32,768				
AA	2-4	BISS B Optical Sine Encoder	Single-turn	2048 Sin/Cos	27-Bits	32-Bits	0.6	19-Bits (Max.)	1	
	5-8							22-Bits (Max.)		
AB	2-4		Multi-turn					19-Bits (Max.)	4,096	
	5-8							22-Bits (Max.)		
C-	1	Smart Feedback Device (SFD)	Single-turn	24-Bits	24-Bits	24-Bits	15	24-Bits	1	
	2-4									8
	5-8									9
CA	1	Smart Feedback Device, Gen. 3 (SFD3)	Single-turn	24-Bits	24-Bits	24-Bits	15	24-Bits	1	
	2-4						8			
	5-6						9			
DA	2-4	EnDat 2.2/01 Optical Sine Encoder	Single-turn	512 Sin/Cos	25-Bits	32-Bits	1	13-Bits	1	
	5-8			2048 Sin/Cos	27-Bits		0.333			
DB	2-4		Multi-turn	512 Sin/Cos	25-Bits		1	13-Bits	4,096	
	5-8			2048 Sin/Cos	27-Bits	0.333				
LA	2-3	EnDat Inductive Encoder	Single-turn	16 Sin/Cos	20-Bits	28-Bits	4.67	18-Bits	1	
	4-8			32 Sin/Cos	21-Bits	29-Bits	3	19-Bits		
LB	2-3			16 Sin/Cos	20-Bits	28-Bits	4.67	18-Bits		4,096
	4-8	32 Sin/Cos	21-Bits	29-Bits	3	19-Bits				
GA/GJ*	2-8	HIPERFACE Optical Sin/Cos Encoder	Single-turn	128 Sin/Cos	23-Bits	31-Bits	1.33	12-Bits	1	
GB/GK*			Multi-turn						4,096	
GE	2-6	HIPERFACE DSL Optical Encoder	Single-turn	18-Bits	18-Bits	18-Bits	1.33	18-Bits	1	
GF			Multi-turn						4,096	
GP**	1	HIPERFACE Capacitive Encoder	Single-turn	16 Sin/Cos	20-Bits	28-Bits	4.8	9-Bits	1	
GR**			Multi-turn							

*ServoStar (Sxxx)/AKD mapped respectively

**AKD mapped ONLY

Servo Motor Feedback Combinations

AKM Family of Servo Motors with Smart Feedback Device (SFD)

The SFD Feedback communicates with the drive over a four-wire interface. Two wires supply up to +5V power at <150 mA and the second pair is an RS-485 digital communications link. The device includes EEPROM memory to save motor parameters.

Angle Measurement:

Resolution: $2^{24} = 16,777,216$ counts per rev
Accuracy: $< \pm 0.75$ arc-min electrical + sensor error
Size 10 sensor: ± 15 arc-min net (AKM 1)
Size 15 sensor ± 8 arc-min net (AKM 2,3,4)
Size 21 sensor ± 9 arc-min net (AKM 5,6,7)
Electrical Noise: $< 2^{-17}$ Rev rms at full bandwidth
Bandwidth: > 2000 Hz at -3 dB
 > 1000 Hz at -45° phase lag
Max Continuous Speed: $> 20,000$ RPM
Velocity Ripple: $< 0.2\%$ p-p electronics only
Size 10 sensor $< 3.0\%$ p-p net (AKM 1)
Size 15 sensor $< 2.0\%$ p-p net (AKM 2-4)
Size 21 sensor $< 2.5\%$ p-p net (AKM 5-8)
Velocity Noise: < 4 RPM rms at full bandwidth

Digital Communications:

Baud Rate: 2.5 Mbaud
Signaling: RS-485 differential, 8 bit data with odd parity compatible with standard UARTs
Update Period: Once every 51.2 uSec new position sample
Error Detection: 5 bit CRC in addition to parity check
EEPROM Memory: Does a data dump when the unit powers up.

Power Supply:

Input Voltage: $5.0\text{ V} \pm 0.50\text{ V}$ (AKM1-4), $2.8\text{V} \pm 0.14\text{ V}$ (AKM5-8)
Input Current Max.: 65 mA (AKM1-4), 46 mA (AKM5-8)
Cable Resistance: +5V, Rtn: < 3.3 Ohm net

Environmental:

Feedback Operating Temperature: -55 to 155° C
Humidity: 10% to 90% non-condensing

AKM Family of Servo Motors with Smart Feedback Device, Gen 3 (SFD3)

The SFD3 Feedback uses a single motor cable, requiring just one cable between the drive and motor. The feedback has both power and communication on a single wire pair, reducing overall wiring costs. In addition, the device includes onboard memory for an electronic motor datasheet.

Angle Measurement:

Resolution: $2^{24} = 16,777,216$ counts per rev
Accuracy: $< \pm 0.45$ arc-sec electrical + sensor error
Size 10 sensor error: ± 15 arc-min net (AKM 1)
Size 15 sensor error: ± 8 arc-min net (AKM 2-4)
Size 21 sensor error: ± 9 arc-min net (AKM 5-8)
Electrical Noise: $< 2^{-17}$ Rev rms at full bandwidth
Bandwidth: > 2000 Hz at -3 dB
 > 1000 Hz at -45° phase lag
Max Continuous Speed: 20,000 RPM
Velocity Ripple: $< 0.2\%$ p-p electronics only
Size 10 sensor: $< 3.0\%$ p-p net (AKM 1)
Size 15 sensor: $< 2.0\%$ p-p net (AKM 2-4)
Size 21 sensor: $< 2.5\%$ p-p net (AKM 5-6)
Velocity Noise: < 4 RPM rms at full bandwidth

Digital Communications:

Baud Rate: 2.5 Mbaud
Signaling: RS-485 differential using differential Manchester encoding
Update Period: Once every 51.2 uSec new position sample
Error Detection: 5 bit CRC and running parity check

Power Supply:

Input Voltage: $5.0\text{ V} \pm 0.50\text{ V}$ (AKM1-4), $2.8\text{V} \pm 0.14\text{ V}$ (AKM5-6)
Input Current Max.: 65 mA (AKM1-4), 46 mA (AKM5-6)

Environmental:

Feedback Operating Temperature: -55 to 155° C
Humidity: 10% to 90% non-condensing

Servo Motor Feedback Combinations

Resolver (Feedback)

Resolver Data	Units	AKM1	AKM2-4	AKM 5-8
		1 Speed	1 Speed	1 Speed
Input Voltage	Vrms (tolerance)	7 (± 10%)	8 (± 5%)	8 (± 5%)
	KHz (tolerance)	10 (± 5%)	8 (± 1%)	8 (± 1%)
Input Current Max.	mA MAX.	30	50	46
Transformation Ratio	± 10%	0.5	0.5	0.5
Null Voltage	mVrms MAX.	50	30	30
Max. Error (pk-pk)	MINS.	30	20	18
Phase Shift	Degrees	-9	0	0
Feedback Operating Temperature	°C	-55° to 155°	-55° to 155°	-55° to 155°
Rotor Inertia Max.	kg-cm ²	0.002	0.046	0.497

Resolver Winding Configuration

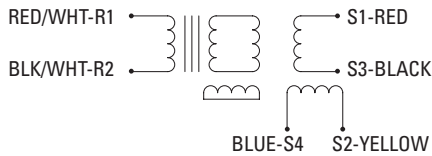

$$E_{R1-R2} = E \sin(\omega T)$$

$$E_{S1-S3} = K E_{R1-R2} \sin \theta$$

$$E_{S2-S4} = K E_{R1-R2} \cos \theta$$

Resolver Alignment

With positive DC current into phase W and out of phase V (U floats) the resolver is aligned to electrical ± 5 counts. ie. Voltage S1-S3 set to null voltage S2-S4 max in phase with reference (R1-R2).

Commutating Encoder Option

Parameter	Units	1- (AKM1-8)	2- (AKM1-8)	ED (AKM2-8)	EE (AKM2-8)	EF (AKM2-4)	EF (AKM5-8)	EG (AKM2-8)	EM (AKM2-8)	EH (AKM2-8)	EN (AKM2-8)	EJ (AKM2-8)
Input Voltage	Vdc ±10%	5										
Output Data	-	TTL Differential Line Driver (Sink/Source 20mA MAX.)										
Line Count per revolution	-	1,024	2,048	500	1,000	2,000	2,000	2,500	4,096	5,000	8,192	10,000
Frequency Response	KHz	200						500			1,000	
Max. Speed	RPM	12,000	12,000	12,000	12,000	12,000	7,500	12,000	7,324	8,000	3,662	3,000
Min. Edge Separation of Incremental Channel	°e MIN.	45										
Index to U Comm Channel	-	±1°m Index Center to U Falling Edge										
Index Pulse Width	-	Gated With B Low										
Incremental Channel Accuracy	-	±1 Arc Min. Max. Edge to Edge										
Max. Acceleration	Rad/s ²	100,000										
Feedback Operating Temperature	°C	-20 to 120										
Storage Temperature	°C	-25 to 120										

Motor Connections

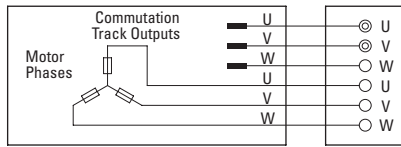

Output Comm: Open Collector W 2.2 k OHMS
External Pull Ups
(SINK 8 mA MAX.)

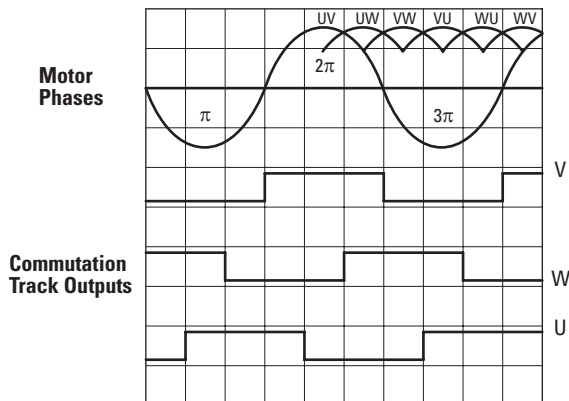

Max. Misalignment between rising edge of commutation track V & zero crossing of back EMF UV ≤ 5° electrical.

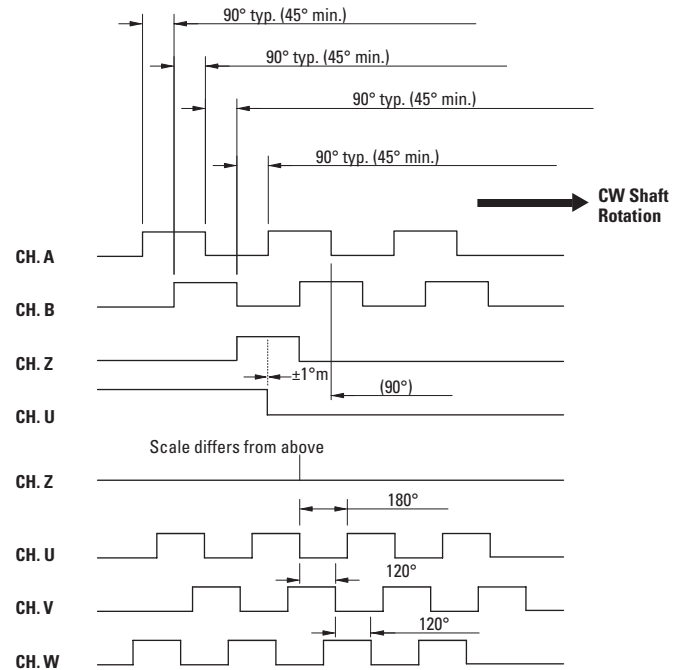

Servo Motor Feedback Combinations

Absolute Sine Encoder Options

Encoder Alignment

With positive DC current into phase W and out of phase V (U floats) the encoder is aligned to ± 1 electrical degree¹.

BiSS Optical

Type		Single-Turn "AA"		Multi-Turn "AB"	
Frame Size		AKM2-4	AKM 5-8	AKM2-4	AKM 5-8
Cycles per Revolution	-	2048	2048	2048	2048
Input Voltage	Vdc (tolerance)	5 (-5%/+10%)	5 ($\pm 10\%$)	5 (-5%/+10%)	5 ($\pm 10\%$)
Current Consumption	mA Typical	100 (without load)	100 (without load)	150 (without load)	100 (without load)
Feedback Operating Temperature	$^{\circ}\text{C}$ MIN./MAX.	-15/120	-15/120	-15/120	-15/120
Inertia	kg-cm ²	0.025	0.038	0.025	0.038
Output Interface		BiSS B			
Manufacturer Product Type		AD34	AD58	AD34	AD58

EnDat Optical

Type		Single-Turn "DA"		Multi-Turn "DB"	
Frame Size		AKM2-4	AKM 5-8	AKM2-4	AKM 5-8
Cycles per Revolution	-	512	2048	512	2048
Input Voltage	Vdc	3.6 to 14	3.6 to 14	3.6 to 14	3.6 to 14
Current Consumption	mA Typical	85 (no load)	85 (no load)	105 (no load)	105 (no load)
Feedback Operating Temperature	$^{\circ}\text{C}$ MIN./MAX.	-40/115	-40/115	-40/115	-40/115
Inertia	kg-cm ²	0.04	0.026	0.04	0.026
Output Interface		HEIDENHAIN EnDat 2.2/01			
Manufacturer Product Type		ECN1113	ECN1313	EQN1125	EQN1325

EnDat Inductive

Type		Single-Turn "LA"		Multi-Turn "LB"	
Frame Size		AKM2-3	AKM 4-8	AKM2-3	AKM 4-8
Sin/Cos period per revolution	-	16	32	16	32
Input Voltage	Vdc	4.75 to 10	4.75 to 10	4.75 to 10	4.75 to 10
Current Consumption	mA Typical, at 5V	85 (no load)	85 (no load)	100	102 (no load)
Feedback Operating Temperature	$^{\circ}\text{C}$ MIN./MAX.	-40/115	-20/115	-40/115	-20/115
Inertia	kg-cm ²	0.002	0.021	0.002	0.021
Output Interface		HEIDENHAIN EnDat 2.1/01			
Manufacturer Product Type		ECI1118	ECI1319	EQI1130	EQI1331

Note 1: EnDat Inductive is aligned to ± 3 electrical degrees

HIPERFACE Options

HIPERFACE DSL

Type		Single-Turn "GE"	Multi-Turn "GF"
Frame Size		AKM2-6	AKM 2-6
Resolution per revolution	bits	18	18
Input Voltage	Vdc	7 to 12	7 to 12
Current Consumption	mA MAX.	150	150
Feedback Operating Temperature	°C MIN./MAX.	-20/115	-20/115
Inertia	kg-cm ²	0.0045	0.0045
Output Interface		Hiperface DSL	
Manufacturer Product Type		EKS36	EKM36

HIPERFACE Absolute Sin/Cos Encoder

Type		Single-Turn "GA/GJ"	Multi-Turn "GB/GK"
Frame Size		AKM2-8	AKM 2-8
Sin/Cos period per revolution	-	128	128
Input Voltage	Vdc	7 to 12	7 to 12
Current Consumption	mA Typical	60	60
Feedback Operating Temperature	°C MIN./MAX.	-20/110	-20/110
Inertia	kg-cm ²	0.0045	0.0045
Output Interface		Absolute Hiperface Sin/Cos Encoder	
Manufacturer Product Type		SKS36	SKM36

*GA/GB Feedbacks are "mapped" for ServoStar (Sxxx) Series drives

**GJ/GK Feedbacks are "mapped" for AKD/AKD2G Series drives.

HIPERFACE Capacitive Encoder

Type		Single-Turn "GP"	Multi-Turn "GR"
Frame Size		AKM1	AKM1
Sin/Cos period per revolution	-	16	16
Input Voltage	Vdc	7 to 12	7 to 12
Current Consumption	mA MAX.	50	50
Feedback Operating Temperature	°C MIN./MAX.	-40/115	-20/115
Inertia	kg-cm ²	0.001	0.001
Output Interface		Capacitive Hiperface Encoder	
Manufacturer Product Type		SEK34	SEL34

AKM[®] Servo Motor Connector Pinouts

Kollmorgen Dual Cable Options – Power & Feedback

B, C, G, H, & T Power Connector Pinouts –

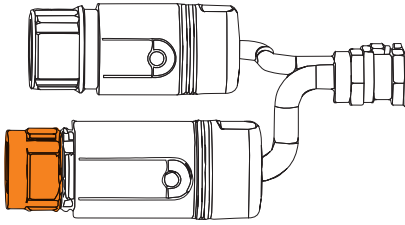

C- Connectors (AKM1 & AKM2 Only)

Connector Part Number: BKJA-199-NN-00-11-0200-000

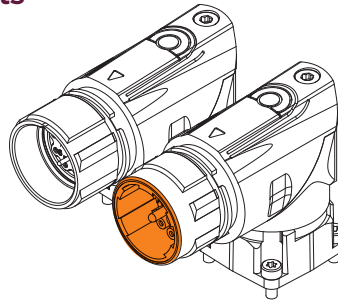

B- Connectors (AKM2 Only)

C- Connectors (AKM3-7)

Connector Part Number: BEDC-110-NN-00-00-1216-000

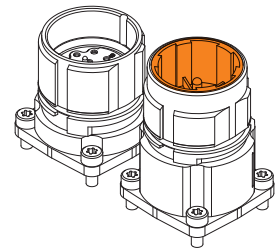

G- Connectors (AKM2 - AKM7)

Connector Part Number: BEGA-120-NN-00-00-0200-000

B-, C- & G- Power Connector Pinout

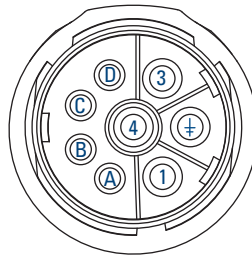

Pin	Function
1	U
2	PE
3	W
4	V
A	Brake +
B	Brake -
C	N/C
D	N/C

H- Connector Pinout

(AKM74Q & AKM82T Only)

Connector Part Number: CEDE-270-NN-00-00-0051-000

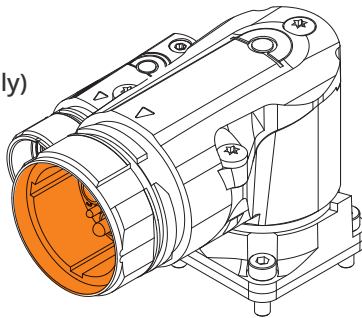

H- Connectors

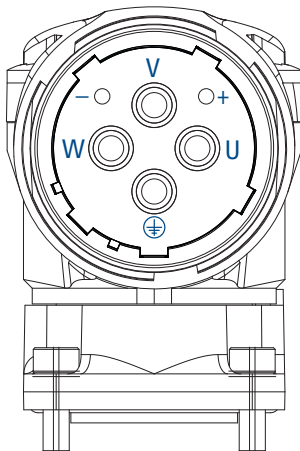

Pin	Function
U	U
PE	PE
W	W
V	V
+	Brake +
-	Brake -

Power Connector (View Facing Front)

T- Connector

(AKM8 Only)

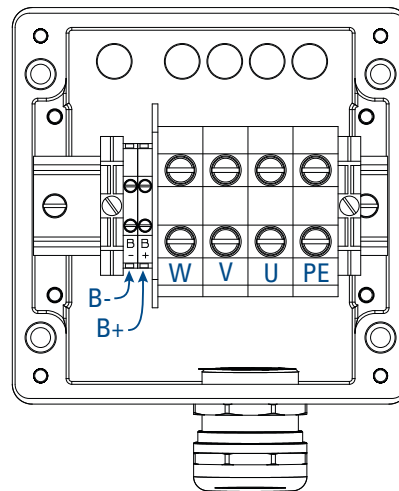
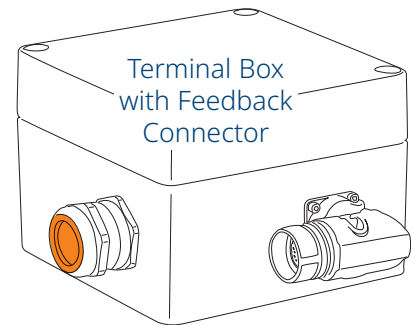

Clamp	Function
U	U
PE	PE
W	W
V	V
B+	Brake +
B-	Brake -

Note: The connector part numbers given are only valid for the "00" and "01" customization/seal option variants. For mating connector selection, please work with TE Connectivity to select the proper option based on your cable design (cable diameter and conductor size). Pinout still valid for AKM Washdown "0W" and AKM Food Grade "0F" Stainless Steel Hummel connector variants.

B, C, G, H, & T Feedback Connector Pinouts –

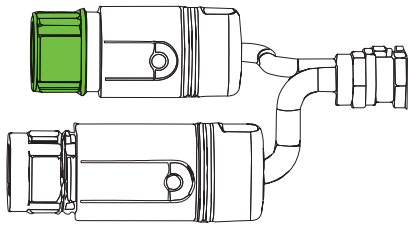

C- Connectors (AKM1 & AKM2 Only)

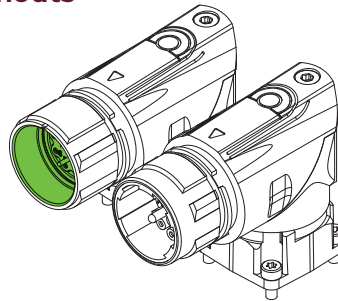

B- Connectors (AKM2 Only)
C- Connectors (AKM3-7)

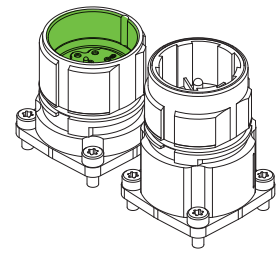

G- Connectors (AKM2 - AKM7)

Connector Part Number:

AKUA-012-NN-00-09-0200-000
(For AKM1 & 2, "C- Connector")

AEDC-110-NN-00-00-1215-000
(For AKM2 "B- Connector", AKM3-7, "C- Connector" and AKM7 & AKM8 "H- Connector")

AEGA-110-NN-00-00-0201-000
(For AKM2-7 "G- Connector")

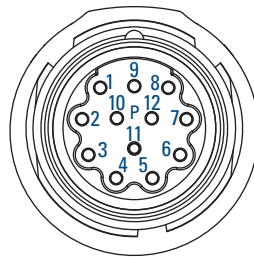

SFD2

Pin	Function
1	SFD +5V
2	SFD +5V RTN
3	SFD COM-
4	SFD COM+
5	SFD COM Shield (AKM 1, 2)
6	N/C
7	N/C
8	N/C
9	N/C
10	N/C
11	N/C
12	N/C

Resolver

Pin	Function
1	N/C
2	Thermal Sensor +
3	S4 COS -
4	S3 SIN -
5	R2 REF -
6	Thermal Sensor -
7	S2 COS +
8	S1 SIN +
9	R1 REF +
10	N/C
11	N/C
12	N/C

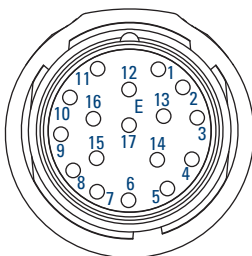

Connector Part Number:

AKUA-015-NN-00-09-0200-000
(For AKM1 & 2, "C- Connector")

AEDC-139-NN-00-00-1215-000
(For AKM2 "B- Connector", AKM3-7, "C- Connector" and AKM7 & AKM8 "H- Connector")

AEGA-139-NN-00-00-0201-000
(For AKM2-7 "G- Connector")

Commutating Encoder

Pin	Function
1	B
2	\bar{B}
3	A
4	\bar{A}
5	Z
6	\bar{Z}
7	GND
8	Thermal Sensor +
9	Thermal Sensor -
10	Vcc
11	N/C
12	N/C
13	N/C
14	N/C
15	U
16	V
17	W

EnDat[®]/BiSS

Pin	Function
1	B -
2	GND
3	A -
4	Vcc
5	DATA
6	N/C
7	Thermal Sensor +
8	Clock
9	B +
10	Un Sense (Common)
11	A +
12	Up Sense (VCC)
13	\bar{DATA}
14	Thermal Sensor -
15	Clock
16	N/C
17	N/C

HIPERFACE[®] Analog

Pin	Function
1	SIN +
2	GND
3	COS +
4	Vcc
5	Data
6	N/C
7	Thermal Sensor +
8	N/C
9	REF SIN
10	N/C
11	REF COS
12	N/C
13	Data
14	Thermal Sensor -
15	N/C
16	N/C
17	N/C

H- Connectors
(AKM74Q - AKM82T Only)

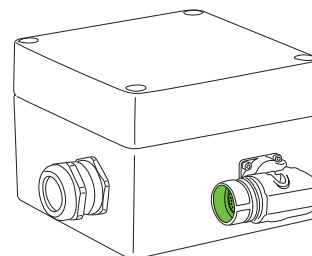
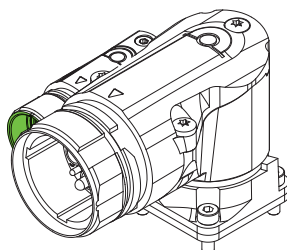

T- Connector
(AKM8 Only)

Note: The connector part numbers given are only valid for the "00" and "01" customization/seal option variants. For mating connector selection, please work with TE Connectivity to select the proper option based on your cable design (cable diameter and conductor size). Pinout still valid for AKM Washdown "0W" and AKM Food Grade "0F" Stainless Steel Hummel connector variants.

AKM[®] Servo Motor Connector Pinouts

Kollmorgen Dual Cable Options – Power & Feedback

ytec[®] - Y- Connector Pinout – AKM1 only

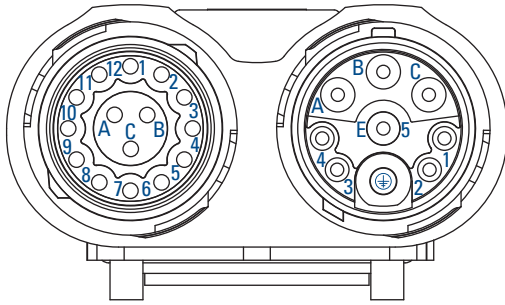

Feedback

Power + Brake

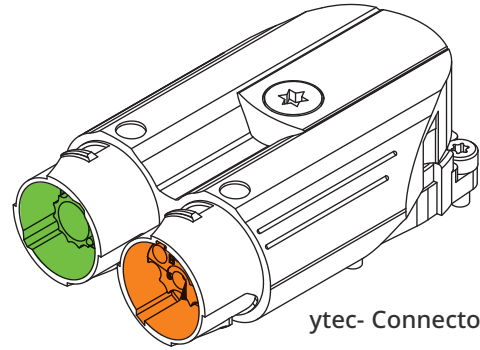

ytec- Connector

Power Connector

Pin	Function
1	BR+
2	BR-
3	N/C
4	N/C
5/E	N/C
A	Phase U
B	Phase W
C	Phase V
⊕	PE

Connector Part Number: See Options for Commutating Encoder or SFD2/Resolver/HIPERFACE

Commutating Encoder

Pin	Function
1	B
2	\bar{B}
3	A
4	\bar{A}
5	Z
6	\bar{Z}
7	GND
8	Thermal Sensor +
9	Thermal Sensor -
10	Vcc
11	N/C
12	N/C
A	U
B	V
C	W

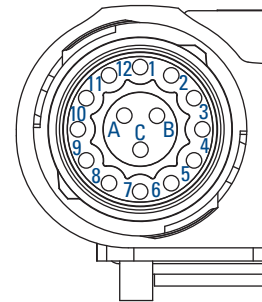

Connector Part Number: EEDA-103-NN-00-00-0001-000

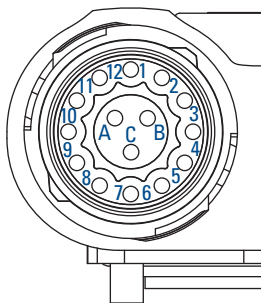

SFD2

Pin	Function
1	SFD +5 V
2	SFD +5 V RTN
3	SFD COM-
4	SFD COM+
5	N/C
6	N/C
7	N/C
8	N/C
9	N/C
10	N/C
11	N/C
12	N/C

Resolver

Pin	Function
1	N/C
2	Thermal Sensor +
3	S4 COS -
4	S3 SIN -
5	R2 REF -
6	Thermal Sensor -
7	S2 COS +
8	S1 SIN +
9	R1 REF +
10	N/C
11	N/C
12	N/C

HIPERFACE[®] Analog

Pin	Function
1	Thermal Sensor +
2	Thermal Sensor -
3	N/C
4	REF SIN
5	REF COS
6	Data +
7	Data -
8	SIN +
9	COS +
10	Vcc
11	GND
12	N/C

Connector Part Number: EEDA-101-NN-00-00-0001-000

Note: The connector part numbers given are only valid for the "00" and "01" customization/seal option variants. For mating connector selection, please work with TE Connectivity to select the proper option based on your cable design (cable diameter and conductor size). Pinout still valid for AKM Washdown "0W" and AKM Food Grade "0F" Stainless Steel Hummel connector variants.

Kollmorgen Hybrid Single Cable Options – Power & Feedback

D- and 9- Connector Pinouts – Hybrid combined power and SFD3 / DSL feedback cable

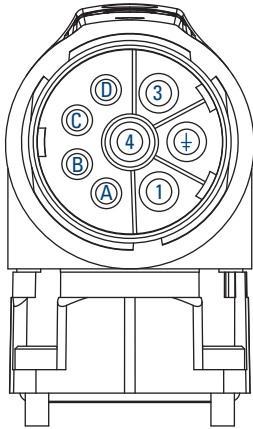

Power + SFD2 /SFD3 / DSL

Power + SFD3 / DSL

Pin	Function
1	U
⊕	PE
3	W
4	V
A	Brake +
B	Brake -
C	SFD - / DSL -
D	SFD + / DSL +

Power + SFD2

Pin	Function
1	U
⊕	PE
3	W
4	V
A	SFD +5 V
B	SFD +5 V RTN
C	SFD COM -
D	SFD COM +

Connector Part Number:
BEDC-110-NN-00-00-1216-000

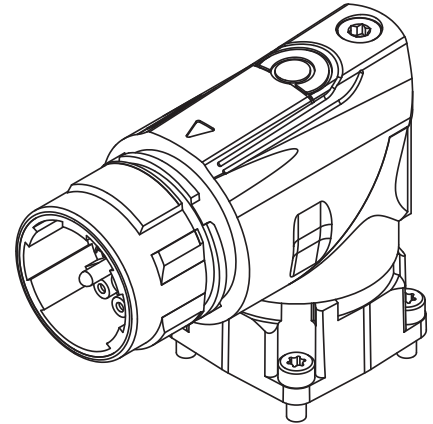

D- Connector

itec® - 9- Connector Pinout – AKM1 only

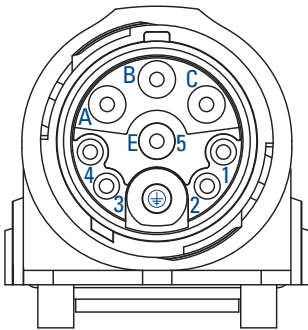

Power + SFD3

Power + SFD3

Pin	Function
1	Brake +
2	Brake -
3	SFD -
4	SFD +
5/E	N/C
A	Phase U
B	Phase W
C	Phase V
⊕	PE

Power + SFD2

Pin	Function
1	SFD +5 V
2	SFD +5 V RTN
3	SFD COM -
4	SFD COM+
5/E	N/C
A	Phase U
B	Phase W
C	Phase V
⊕	PE

Connector Part Number:
EEDA-201-NN-00-00-0800-000

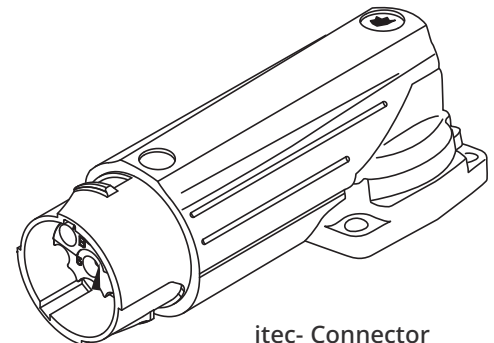

itec- Connector

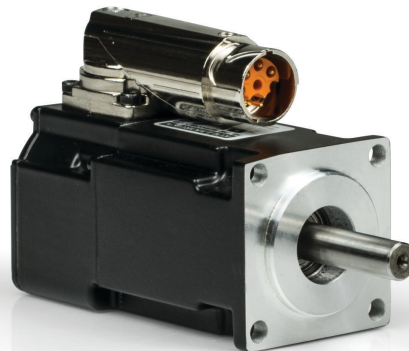

AKM1 with itec Connector

Note: The connector part numbers given are only valid for the "00" and "01" customization/seal option variants. For mating connector selection, please work with TE Connectivity to select the proper option based on your cable design (cable diameter and conductor size). Pinout still valid for AKM Washdown "0W" and AKM Food Grade "0F" Stainless Steel Hummel connector variants.

AKM[®] Servo Motor Connector Pinouts

"M" Power Connector Options

(AKM 1, 2, 3 & 4 Only) If additional dimensions or connectors are required, contact Kollmorgen Customer Support.

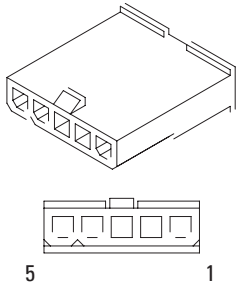

Power Connector - No Brake

Pin	Function	Color
1	U	Blue
2	V	Brown
3	W	Violet
4	Gnd	Grn/Yel
5	Shield	

Shield Connected to Motor
Ground Internal to Motor

Power Connector - Brake

Pin	Function	Color
1	U	Blue
2	V	Brown
3	W	Violet
4	Gnd	Grn/Yel
5	Shield	
6	Brake+	Black
7	Brake-	Black
8	N/C	

Shield Connected to Motor
Ground Internal to Motor

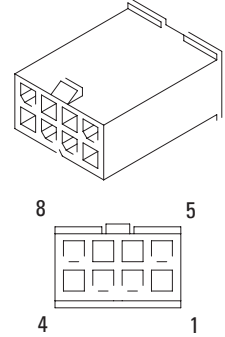

"M" Feedback Connector Options

SFD

Pin	Function	Color
1	SFD +5V	Red
2	SFD +5V RTN	Black
3	SFD COM-	Yellow
4	SFD COM+	Blue
5	SFD COM Shield	
6	N/C	
7	N/C	
8	N/C	
9	N/C	
10	N/C	

Shield is Not Connected at Motor End

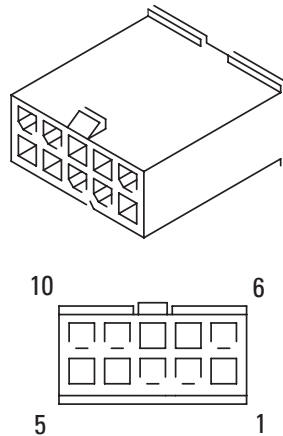

Resolver

Pin	Function	Color
1	N/C	
2	Thermal Sensor +	Orange
3	S4, COS-	Blue
4	S3, SIN-	Black
5	R2, REF-	Blk/Wht
6	Thermal Sensor -	Orange/White
7	S2, COS+	Yellow
8	S1, SIN+	Red
9	R1, REF+	Red/Wht
10	Shield	

Shield is Not Connected at Motor End

Commutating Encoder

Pin	Function	Color
1	B	Green
2	B̄	Grn/Blk
3	A	Blue
4	Ā	Blue/Blk
5	Z	Violet
6	Z̄	Violet/Blk
7	Gnd	Black
8	Thermal Sensor +	Orange
9	Thermal Sensor -	Orange/White
10	Vcc	Red
11	N/C	
12	N/C	
13	N/C	
14	N/C	
15	U	Brown
16	V	Grey
17	W	White
18	Shield	

Shield is Not Connected at Motor End

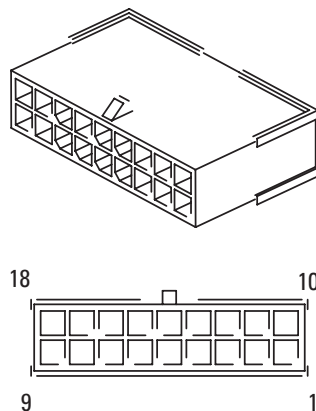

Absolute Encoder

Pin	"AA" & "AB"	DA, DB & LA, LB	Color
1	B-	B-	Red/Blk
2	Gnd	Gnd	Wht/Grn
3	A-	A-	Yel/Blk
4	Vcc (5Vdc)	Vcc (5Vdc)	Brn/Grn
5	Data	Data	Gray
6	N/C	N/C	
7	Thermal Sensor+	Thermal Sensor+	Green
8	Clock	Clock	Violet
9	B+	B+	Blu/Blk
10	Un Sense (Common)	Un Sense (Common)	White
11	A+	A+	Grn/Blk
12	Up Sense (VCC)	Up Sense (VCC)	Blue
13	Data	Data	Pink
14	Thermal Sensor-	Thermal Sensor-	Brown
15	Clock	Clock	Yellow
16	N/C	N/C	
17	N/C	N/C	
18	N/C	Shield	

Shield is Not Connected at Motor End

"P" Power + SFD Connector Option

(AKM 1, 2, 3 & 4 Only - Not available for Brake Motors)

Combined Power & SFD Feedback

Pin	Function	Color
1	SFD +5V	Red
2	SFD +5V RTN	Black
3	Power Shield	
4	Ground	Grn/Yel
5	U	Blue
6	SFD COM-	Yellow
7	SFD COM+	Blue
8	SFD COM Shield	
9	V	Brown
10	W	Violet

Power Shield Connected to Motor Ground Internal to Motor

Feedback Shield is Not Connected at Motor End

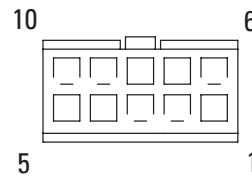
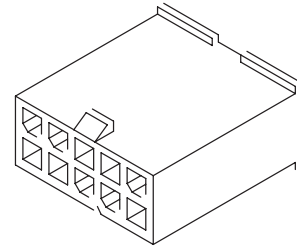

Molex® Connector-Cable Lookup Table

(AKM 1, 2, 3 & 4 Only)



Molex® Cable Mating Connectors

Cable Function	Connector Option Code	Motor Cable Connector	Motor Cable Composition	Mating Connector
Power	M	Molex 39-01-4056 (Eng No. 5559-05P3)	5-Pin Power Connector - No Brake	Molex 39-01-4050
		Molex 39-01-3083 (Eng No. 5559-08P1)	8-pin Power Connector with Brake	Molex 39-01-2080
Molex 43020-1001		8-Pin SFD	Molex 43025-1000	
Molex 43020-1001		8-Pin Resolver	Molex 43025-1000	
Feedback		Molex 43020-1801	18-Pin Commutating Encoder	Molex 43025-1800
		Molex 43020-1801	18-Pin Absolute Encoder DA, DB, LA, LB	Molex 43025-1800
		Molex 43020-1801	18-Pin Absolute Encoder AA, AB	Molex 43025-1800
	Molex 43020-1801	18-Pin Absolute Encoder AA, AB	Molex 43025-1800	
Power + SFD	P	Molex 39-01-3103 (Eng No. 5559-10P1)	10-Pin Power + SFD - No Brake	Molex 39-01-2100

Kollmorgen Cable Lookup Tables

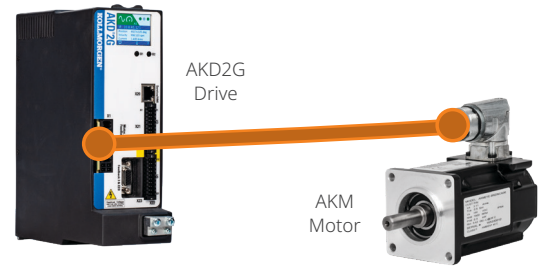

Smart Feedback Device (SFD3) – AKM® motor to AKD®2G drive

Motor Feedback	Drive	Motor Connector	Current Rating ¹	Hybrid Cable (PUR) ²	Hybrid Cable (PVC) ³
SFD3 (CA)	AKD2G-SPx-6V03x AKD2G-SPx-6V06x AKD2G-SPx-6V12x	itec® AKM1 only	Rms<11	H2-21-010-C4-00-XXXX00	H6-21-010-C4-00-XXXX00
	AKD2G-SPx-7V03x AKD2G-SPx-7V06x AKD2G-SPx-7V12x	SpeedTec® (D)	Rms < 15	H2-21-015-A5-00-XXXX00	H6-21-015-A5-00-XXXX00

HIPERFACE DSL® – AKM® motor to AKD®2G drive

Motor Feedback	Drive	Motor Connector	Current Rating ¹	Hybrid Cable (PUR) ²	Hybrid Cable (PVC) ³
HIPERFACE DSL (GE, GF)	AKD2G-SPx-6V03x AKD2G-SPx-6V06x AKD2G-SPx-6V12x AKD2G-SPx-7V03x AKD2G-SPx-7V06x AKD2G-SPx-7V12x	SpeedTec® (D)	Rms < 15	H2-21-015-A5-00-XXXX00	H6-21-015-A5-00-XXXX00

Notes:

1. Current ratings used on a IEC 60364-5-52 standard
2. PUR cables have a Polyurethane cable jacket material typically used in Europe
3. PVC cables have a Polyvinyl Chloride cable jacket material typically used in North America

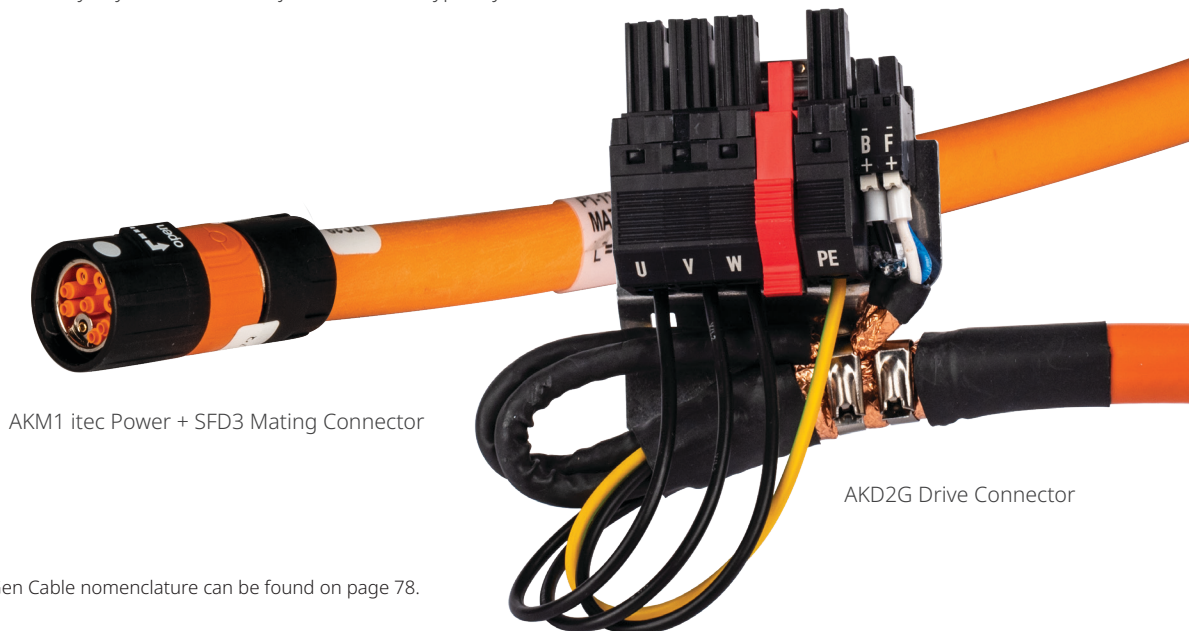

*Complete Next-Gen Cable nomenclature can be found on page 78.

H6 - 21 - 015 - A5 - 00 *

Cable Version Drive Connector Wire X-section Motor Mating Connector Customization Length

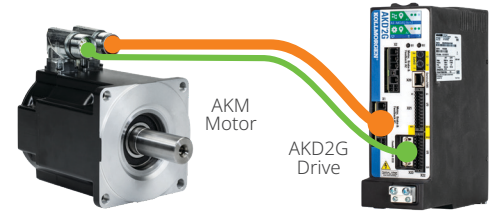

Resolver – AKM® motor to AKD®2G drive

Motor Feedback	Drive	Motor Connector	Current Rating ¹	Brake Option	Power Cable (PUR) ² + 00-XXXX00	Power Cable (PVC) ³ + 00-XXXX00	Feedback Cable (PUR) ² + 00-XXXX00	Feedback Cable (PVC) ³ + 00-XXXX00
Resolver (R-)	AKD2G-SPx-6V03x AKD2G-SPx-6V06x AKD2G-SPx-6V12x	ytec (Y)	Rms < 15	No Brake	P1-21-015-C1-	P5-21-015-C1-	F1-10-FB2-C2-	F5-10-FB2-C2-
				Brake	P2-21-015-C1-	P6-21-015-C1-		
	AKD2G-SPx-7V03x AKD2G-SPx-7V06x AKD2G-SPx-7V12x	SpeedTec (C or G)	Rms < 15	No Brake	P1-21-015-A5-	P5-21-015-A5-	F1-10-FB2-A2-	F5-10-FB2-A2-
				Brake	P2-21-015-A5-	P6-21-015-A5-		

Smart Feedback Device – AKM® motor to AKD®2G drive

Motor Feedback	Drive	Motor Connector	Current Rating ¹	Brake Option	Power Cable (PUR) ² + 00-XXXX00	Power Cable (PVC) ³ + 00-XXXX00	Feedback Cable (PUR) ² + 00-XXXX00	Feedback Cable (PVC) ³ + 00-XXXX00
Smart Feedback Device (C-)	AKD2G-SPx-6V03x AKD2G-SPx-6V06x AKD2G-SPx-6V12x	ytec (Y)	Rms < 15	No Brake	P1-21-015-C1-	P5-21-015-C1-	F1-18-FB3-C2-	F5-18-FB3-C2-
				Brake	P2-21-015-C1-	P6-21-015-C1-		
	AKD2G-SPx-7V03x AKD2G-SPx-7V06x AKD2G-SPx-7V12x	SpeedTec (C or G)	Rms < 15	No Brake	P1-21-015-A5-	P5-21-015-A5-	F1-18-FB3-A2-	F5-18-FB3-A2-
				Brake	P2-21-015-A5-	P6-21-015-A5-		

Notes:

1. Current ratings used on a IEC 60364-5-52 standard
2. PUR cables have a Polyurethane cable jacket material typically used in Europe
3. PVC cables have a Polyvinyl Chloride cable jacket material typically used in North America

*Complete Next-Gen Cable nomenclature can be found on page 78.

Kollmorgen Cable Lookup Tables

Dual Cable Options – Power and Feedback

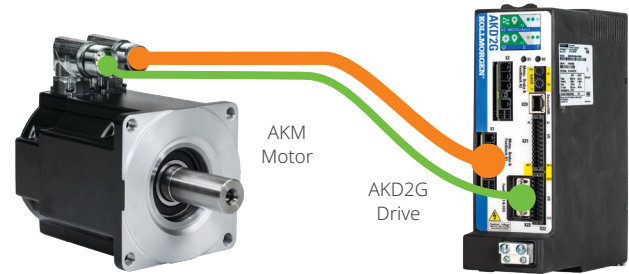

Commutating Encoder – AKM® motor to AKD®2G drive

Motor Feedback	Drive	Motor Connector	Current Rating ¹	Brake Option	Power Cable (PUR) ² + 00-XXXX00	Power Cable (PVC) ³ + 00-XXXX00	Feedback Cable (PUR) ² + 00-XXXX00	Feedback Cable (PVC) ³ + 00-XXXX00
Sine/Incr. Encoder w/ Halls (Ex, 1-,2-)	AKD2G-SPx-6V03x AKD2G-SPx-6V06x AKD2G-SPx-6V12x	ytec® (Y)	Rms < 15	No Brake	P1-21-015-C1-	P5-21-015-C1-	F1-20-FB4-C3-	F5-20-FB4-C3-
				Brake	P2-21-015-C1-	P6-21-015-C1-		
	AKD2G-SPx-7V03x AKD2G-SPx-7V06x AKD2G-SPx-7V12x	SpeedTec® (C or G)	Rms < 15	No Brake	P1-21-015-A5-	P5-21-015-A5-	F1-20-FB4-A3-	F5-20-FB4-A3-
				Brake	P2-21-015-A5-	P6-21-015-A5-		

EnDat®/BiSS Encoder – AKM® motor to AKD®2G drive

Motor Feedback	Drive	Motor Connector	Current Rating ¹	Brake Option	Power Cable (PUR) ² + 00-XXXX00	Power Cable (PVC) ³ + 00-XXXX00	Feedback Cable (PUR) ² + 00-XXXX00	Feedback Cable (PVC) ³ + 00-XXXX00	
EnDat/BiSS (Ax, Dx, Lx)	AKD2G-SPx-6V03x AKD2G-SPx-6V06x AKD2G-SPx-6V12x	SpeedTec (C or G)	Rms < 15	No Brake	P1-21-015-A5-	P5-21-015-A5-	F1-12-FB4-A3-	F5-12-FB4-A3-	
				Brake	P2-21-015-A5-	P6-21-015-A5-			
	AKD2G-SPx-7V03x AKD2G-SPx-7V06x AKD2G-SPx-7V12x				No Brake	P1-21-015-A5-	P5-21-015-A5-	F1-12-FB4-A3-	F5-12-FB4-A3-
					Brake	P2-21-015-A5-	P6-21-015-A5-		

HIPERFACE® Optical Sine Encoder – AKM® motor to AKD®2G drive

Motor Feedback	Drive	Motor Connector	Current Rating ¹	Brake Option	Power Cable (PUR) ² + 00-XXXX00	Power Cable (PVC) ³ + 00-XXXX00	Feedback Cable (PUR) ² + 00-XXXX00	Feedback Cable (PVC) ³ + 00-XXXX00
HIPERFACE (Gx)	AKD2G-SPx-6V03x AKD2G-SPx-6V06x AKD2G-SPx-6V12x	ytec (Y)	Rms < 15	No Brake	P1-21-015-C1-	P5-21-015-C1-	F1-14-FB6-C2-	F5-14-FB6-C2-
				Brake	P2-21-015-C1-	P6-21-015-C1-		
	AKD2G-SPx-7V03x AKD2G-SPx-7V06x AKD2G-SPx-7V12x	SpeedTec (C or G)	Rms < 15	No Brake	P1-21-015-A5-	P5-21-015-A5-	F1-14-FB6-A3-	F5-14-FB6-A3-
				Brake	P2-21-015-A5-	P6-21-015-A5-		

Notes:

1. Current ratings used on a IEC 60364-5-52 standard
2. PUR cables have a Polyurethane cable jacket material typically used in Europe
3. PVC cables have a Polyvinyl Chloride cable jacket material typically used in North America

2G Value Line Cable Options for AKD2G Drives

Hybrid Single Cable Options

Kollmorgen is also excited to offer a new line of 2G Value Line Cables. These cables will pair with all of our AKM2G & AKD2G offerings and will be available in both dual cable and hybrid cable options. Similar to the current Value line cables the 2G Value Line cables will excel in static applications where cost is key.

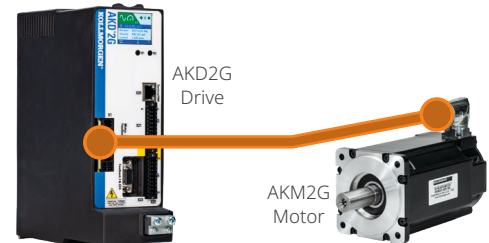

AKD®2G drive to AKM®2G and AKM motors

Motor Feedback	Motor Connector	Current Rating ¹	AKM2G Hybrid Cable	AKM Hybrid Cable
SFD3	SpeedTec® (D)	Rms < 15 A	H6-21-015-A1-VL-XXXX00	H6-21-015-A5-VL-XXXX00
		Rms < 20 A	H6-21-025-A1-VL-XXXX00	H6-21-025-A5-VL-XXXX00
EnDAT/BiSS		Rms < 15 A	H6-21-015-B2-VL-XXXX00	-
		Rms < 15 A	H6-21-015-B1-VL-XXXX00	H6-21-015-A5-VL-XXXX00
HIPERFACE DSL		Rms < 20 A	H6-21-025-B1-VL-XXXX00	H6-21-025-A5-VL-XXXX00

Dual Cable Options

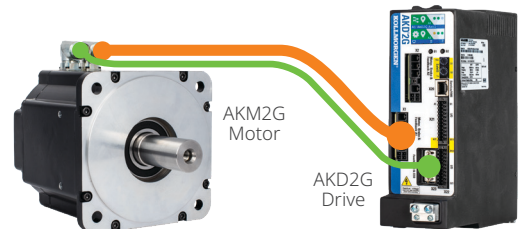

AKD®2G drive to AKM®2G and AKM motors

Motor Feedback	Motor Connector	Current Rating ¹	Brake Option	AKM2G Power Cable	AKM Power Cable	Feedback Cable
Comcoder	SpeedTec® (C or G)	Rms < 15 A	No Brake	P5-21-015-A1-VL-XXXX00	P5-21-015-A5-VL-XXXX00	F5-20-FB4-A3-VL-XXXX00
			Brake	P6-21-015-A1-VL-XXXX00	P6-21-015-A5-VL-XXXX00	
		Rms < 20 A	No Brake	P5-21-025-A1-VL-XXXX00	P5-21-025-A5-VL-XXXX00	
			Brake	P6-21-025-A1-VL-XXXX00	P6-21-025-A5-VL-XXXX00	
Resolver		Rms < 15 A	No Brake	P5-21-015-A1-VL-XXXX00	P5-21-015-A5-VL-XXXX00	F5-10-FB2-A3-VL-XXXX00
			Brake	P6-21-015-A1-VL-XXXX00	P6-21-015-A5-VL-XXXX00	
		Rms < 20 A	No Brake	P5-21-025-A1-VL-XXXX00	P5-21-025-A5-VL-XXXX00	
			Brake	P6-21-025-A1-VL-XXXX00	P6-21-025-A5-VL-XXXX00	
EnDAT/BiSS	Rms < 15 A	No Brake	P5-21-015-A1-VL-XXXX00	P5-21-015-A5-VL-XXXX00	F5-12-FB4-A3-VL-XXXX00	
		Brake	P6-21-015-A1-VL-XXXX00	P6-21-015-A5-VL-XXXX00		
	Rms < 20 A	No Brake	P5-21-025-A1-VL-XXXX00	P5-21-025-A5-VL-XXXX00		
		Brake	P6-21-025-A1-VL-XXXX00	P6-21-025-A5-VL-XXXX00		
HIPERFACE DSL	Rms < 15 A	No Brake	-	P5-21-015-A5-VL-XXXX00	F5-14-FB6-A3-VL-XXXX00	
		Brake	-	P6-21-015-A5-VL-XXXX00		
	Rms < 20 A	No Brake	-	P5-21-025-A5-VL-XXXX00		
		Brake	-	P6-21-025-A5-VL-XXXX00		

AKD® Servo Drive Cable Lookup Tables

AKD® Performance Cables

Hybrid Single Cable Options

Hybrid cables offer a single connection point on the motor for both feedback and power. Feedback options for this connection type are:

- » SFD3 (Single-turn absolute, CA option)
- » HIPERFACE® DSL (Single-turn absolute, GE option)
- » HIPERFACE DSL (Multi-turn option, GF option)

Washdown versions of this cable are also available.

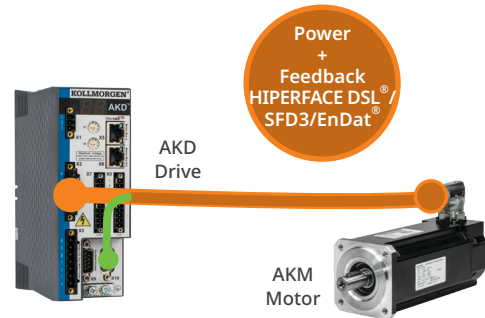

AKD Performance Hybrid Cables by Motor Type

Motor	Hybrid Cable ¹ option for 240V drives (AKD-xxxx06xxxx)	Hybrid Cable ¹ option for 480V drives (AKD-xxxx07xxxx)
AKM < 12 A	CCJ1A2-015	CCJ2A2-015
12 A ≤ AKM < 20 A	CCJ2A2-025	CCJ2A2-025
Washdown AKM < 12 A	WCJ1A1-015	WCJ2A1-015
12 A ≤ Washdown AKM < 20 A	WCJ2A1-025	WCJ2A1-025

¹ Hybrid cables support SFD GEN 3, Single-turn and Multi-turn HiPerFace DSL

Dual Cable Options

Dual cables are used to separate power and feedback. Options included in this catalog support:

- » HIPERFACE (Single-turn absolute, GJ option)
- » HIPERFACE (Multi-turn absolute, GK option)
- » EnDat (Single-turn, LA option)
- » EnDat (Multi-turn, LB option)
- » BiSS (Single-turn absolute, AA option)
- » BiSS (Multi-turn absolute, AB option)

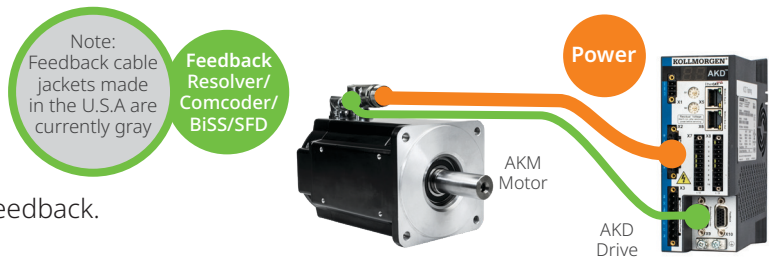

AKD Performance Dual Cables by Motor Type

AKM Motor	Power Cable	Power Cable with Brake	SFD	EnDat 2.2, 01& BiSS
AKM < 12 A	CP-507CCAN	CP-507CDAN	CF-DA0374N	CF-SB7374N
12 A ≤ AKM < 20 A	CP-507DCAN	CP-507DDAN	CF-DA0374N	CF-SB7374N
20 A ≤ AKM < 24 A	CP-508EDBN	CP-508EDBN	CF-DA0374N	CF-SB7374N

AKD[®]-N Performance Cables

Hybrid Single Cable Options

Hybrid Cable Connecting AKD-N Axis Module to AKM[®] Motor

Part Number	Description
CCJNA3-015-xxmyy-00	Hybrid cable connecting AKD-N to AKM1 (SFD GEN3, Single-turn/Multi-turn HiPerFace DSL)
CCJNA2-015-xxmyy-00	Hybrid cable connecting AKD-N to AKM2-8 (SFD GEN3, Single-turn/Multi-turn HiPerFace DSL)

Length definition: xx=meters, yy=centimeters

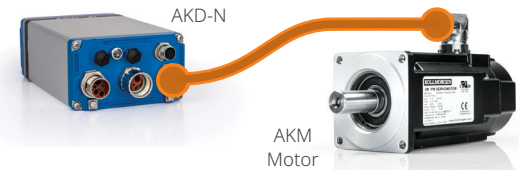

Dual Cable Options

Performance Cables for AKD-N-DF/DS to AKM Motor

Motor	Connector	Power Cable	Power Cable with Brake	SFD
AKM < 6 A	y-tec	CM0NA3	CM1NA3	CFSNA3
	Dual Interconnect	CM0NA2	CM1NA2	CFSNA2

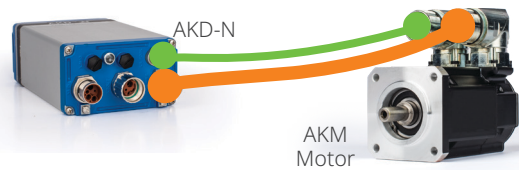

AKD[®] Value Line Cables

Dual Cable Options

Value Line Cables are alternative cable options suitable for most applications. These cables separate power and feedback. Options included in this catalog support Single-turn (GJ) and Multi-turn (GK) for AKD.

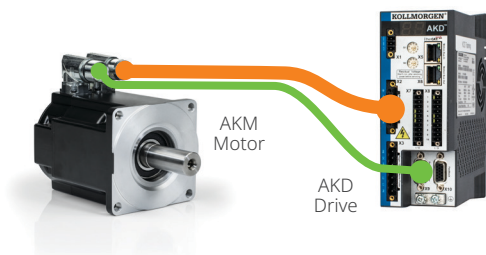

AKD Value Line Dual Cables by Motor Type

AKM Motor	Power Cable	Power Cable with Brake	Comcoder	SFD2	Reilsolver	EnDat 2.2, 01 & BiSS
AKM < 6 A MOLEX	VP-H-507BECN	VP-H-507BFDN	VF-H-CD4474N	VF-H-DC0474N	-	-
AKM < 6 A	VP-H-507BEAN	VP-H-508CFAN	-	VF-H-DA0474N	VF-H-RA2474N	VF-H-SB7374N
6 A ≤ AKM < 12 A	VP-H-508CEAN	VP-H-508CFAN	-	VF-H-DA0474N	VF-H-RA2474N	VF-H-SB7374N

Cable Nomenclature

Kollmorgen Next-Gen Cables

H2 - 12 - 015 - A1 - 00 - XXXX00

Cable Version

Cable Jacket Material - PUR

- F1 Mid-flex Feedback Cable PUR
- H2 Mid-flex Hybrid PUR with brake
- P1 Power Cable PUR
- P2 Power Cable PUR with brake

Cable Jacket Material - PVC

- F5 Mid-flex Feedback Cable PVC
- H6 Mid-flex Hybrid PVC with brake
- P5 Mid-flex Power Cable PVC
- P6 Mid-flex Power Cable PVC with brake

Length (no less than 100 mm increments)

xxxx00 Length in mm
 Standard lengths: 1 - 25 m
 Example:
 6 m cable = 006000
 25 m cable = 025000

Options

- 00 Standard Option Set
- VL Value Line
- XX Specials (excluding standard option set)

Connector Type

If Feedback, connector type [connector type and pinout]

- 10 AKD, AKD2G, 15 Pin D-Sub, 45° angle, Resolver
- 12 AKD, AKD2G, 15 Pin D-Sub, 45 degree angle, EnDat[®] 2.1, BiSS B
- 14 AKD, AKD2G, 15 Pin D-sub, 45 degree angle, HIPERFACE[®]
- 18 AKD, AKD2G, 15 Pin D-sub, 45 degree angle, SFDG2
- 20 AKD, AKD2G, 15 Pin D-sub, 45 degree angle, Comcoder, Sine Enc. w/ Halls
- 41 S300/S700 Resolver 9 pin D-sub
- 42 S300/S700 Encoder 15 pin D-sub (EnDat[®] 2.2, Biss C)
- 43 S300/S700 Encoder 15 pin D-sub (Sine Encoder w Halls)
- 91 Flying leads, Resolver
- 92 Flying leads, EnDat, Biss
- 93 Flying leads, HIPERFACE
- 94 Flying leads, SFD2G
- 95 Flying leads, Comcoder

If Power or Hybrid drive connector type

- 11 AKD-x00306, -x00606 (Power and Hybrids with HDSL, SFD3)
- 12 AKD-x01206, -x02406 (Power and Hybrids with HDSL, SFD3)
- AKD-x00307, -x00607, -x01207, -x02407 (Power and Hybrids with HDSL, SFD3)
- 13 AKD-x04807 (Power and Hybrids with HDSL, SFD3)
- 14 AKD-x00306, -x00606 (Hybrids with EnDat 2.2)
- 15 AKD-x01206, -x02406 (Hybrids with EnDat 2.2)
- AKD-x00307, -x00607, -x01207, -x02407 (Hybrids with EnDat 2.2)
- 21 AKD2G-x00306, -x00606, -x01206
- AKD2G-x00307, -x00607, -x01207, -x02406, -x02407
- 33 AKD-N DB (Hybrid cable)
- 34 AKD-N DF/DS (Power cable)
- 41 S300 MV (Power or Hybrid w/ SFDG3, DSL)
- 42 S300 HV (Power or Hybrid w/ SFDG3, DSL)
- 43 S300 MV (Hybrid with EnDat 2.2-22)
- 44 S300 HV (Hybrid with EnDat 2.2-22)
- 46 S701-S724 connector (Power or Hybrid w/ SFDG3, HDSL)
- 47 S701-S724 connector (Hybrid with EnDat 2.2-22)
- 48 S748/S772 flying leads
- 01 Unterminated flying leads
- SP Special

Motor Mating Connector Type

Hybrid / Power Connectors (#Pins)

- A1 AKM2G, M23 SpeedTec[®] (9)
- A4 AKM2G, M40 SpeedTec (9)
- A5 AKM1G, M23 SpeedTec (8)
- A6 AKM1G, M23 Screw-type (8)
- A7 AKM1G, M40 SpeedTec (6)
- B1 AKM2G, M23 htec (9) (standard keying, DSL)
- B2 AKM2G, M23 htec (13) (rotated keying, EnDat 2.2)
- B3 AKM2G, M40 htec (11) (standard keying, DSL)
- C1 AKM/AKM2G, M15 ytec[®] (9)
- C4 AKM, M15 itec (9) (SFD3)
- UB Unterminated (Blunt Cut)
- UF Unterminated (Flying leads)
- W5 AKM, M23 Hummel Washdown (8)

Feedback Connectors

- A2 AKM/AKM2G, M23 SpeedTec (12)
- A3 AKM/AKM2G, M23 SpeedTec (17)
- C2 AKM/AKM2G, M15 ytec (12)
- C3 AKM/AKM2G, M15 ytec (15)
- UB Unterminated (Blunt cut)
- UF Unterminated (flying leads)
- W2 AKM, M23 Hummel Washdown (12)
- W3 AKM, M23 Hummel Washdown (17)

Cable Type

If Feedback, type [cable construction, not pinout]		If Power or Hybrid drive connector type	
FB1	4 Conductor	010	1.0 mm ²
FB2	8 Conductor	015	1.5 mm ²
FB3	6 Conductor	025	2.5 mm ²
FB4	16 Conductor	040	4.0 mm ²
FB5	14 Conductor	060	6.0 mm ²
FB6	10 Conductor	100	10.0 mm ²
FB7	12 Conductor		

AKD® Drive Performance and Value Line Cables

Feedback Cables

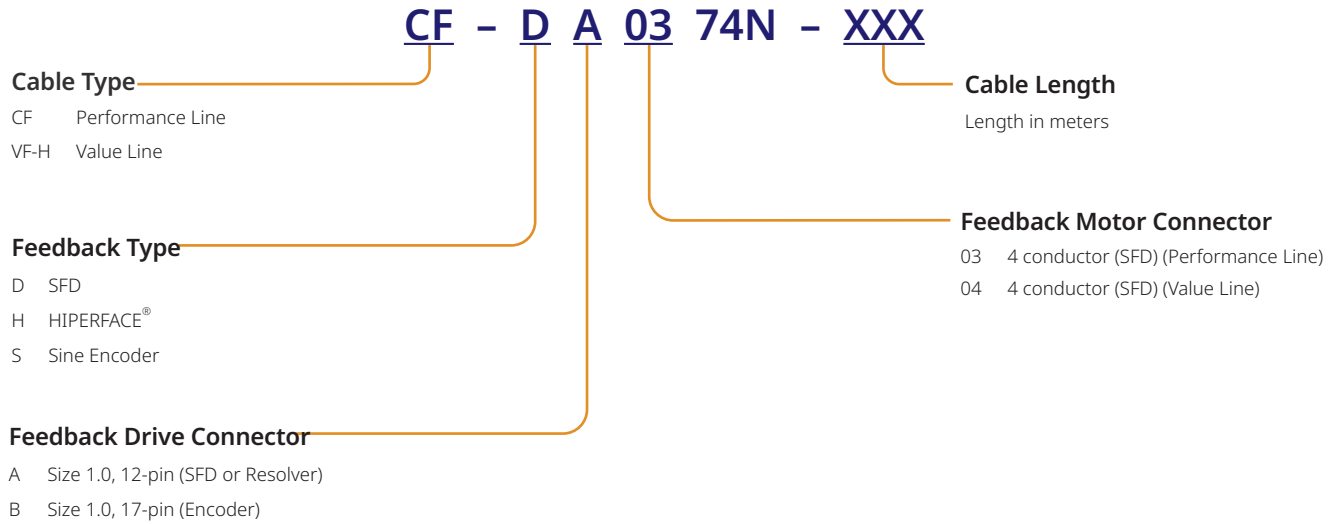

Power Cables

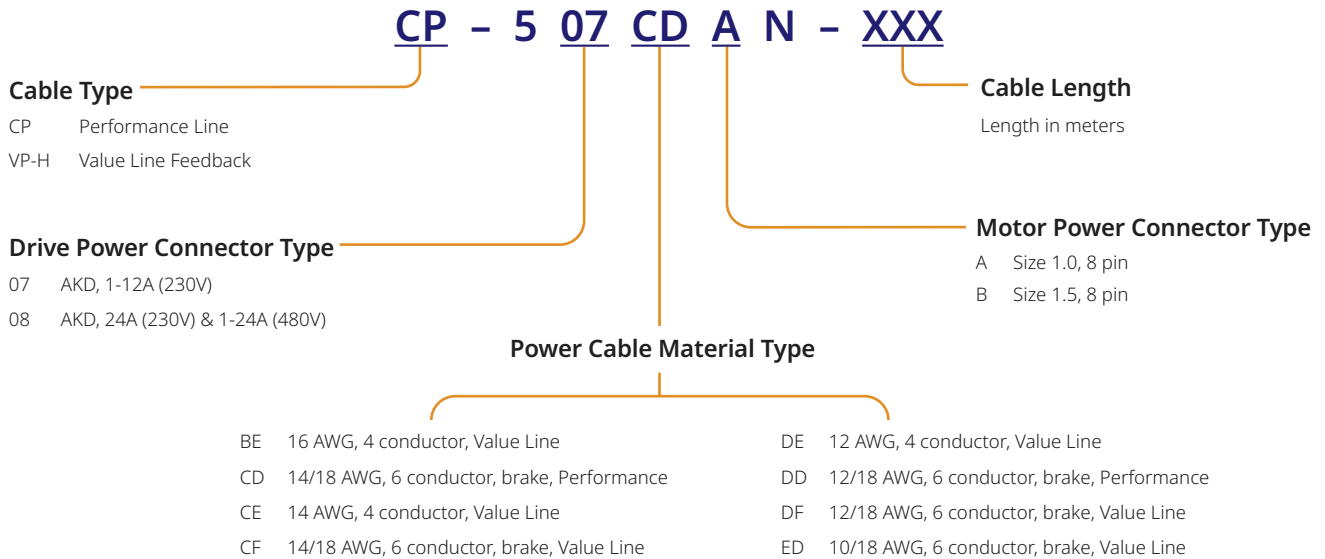

Hybrid (Power + Feedback) Cables

Refer to the AKD Drive Cables (Centralized) nomenclature page 80.

Cable Nomenclature

AKD® Drive Cables (Centralized)

CC J 1 A2 - 015 - 003 - 00

Cable Version

Power

- CM Motor power
- WM Washdown motor power

Feedback

- CF Motor Feedback
- WF Washdown motor feedback

Hybrid (Power + Feedback)

- CC Motor hybrid
- WC Washdown motor hybrid

Fieldbus

- CB Motor hybrid
- WB Washdown motor hybrid

Cable Type

Power

- 0 No Brake
- 1 Brake

Feedback

- C Commutating Encoder
- D EnDat/BiSS digital
- E EnDat®/BiSS
- H HIPERFACE®
- R Resolver
- S SFD

Hybrid (Power + Feedback)

- S SDF + power
- J SDF3/D5L + power and brake

Fieldbus

- P CANopen®

Drive Connector Type

- X No connector (cut off)

Power / Hybrid (Power + Feedback)

- 1 AKD-x00306, -x00606
- 2 AKD-x01206, -x02406, -x00307, -x02407
- 3 AKD-x04807

Feedback

- 0 AKD X10
- 1 AKD X9

Fieldbus

- 0 AKD

Motor Connector Type

- XX No connector (cut off)
- 00 Special connector

Power

- A1 AKM & C/CH connector 1.0
- A2 AKM SpeedTec® 1.0
- A3 AKM itec connector
- A4 AKM molex, 10 pin
- A5 AKM connector 1.5, 8 pin
- A6 AKM molex, 5 pins
- A7 AKM molex, 8 pins
- AK AKM terminal box
- DL Linear motors

Feedback

- A1 AKM & C/CH connector 1.0
- A2 AKM SpeedTec® 1.0
- A3 AKM ytec® connector
- A4 AKM molex, 10 pins
- A5 AKM molex 18 pins
- DL Linear motors
- E1 EnDat ext.
- E2 HIPERFACE ext.

Hybrid (Power + Feedback)

- A1 AKM & C/CH connector 1.0
- A2 AKM SpeedTec® 1.0
- A3 AKM itec connector
- A4 AKM molex, 10 pin
- A5 AKM connector 1.5, 8 pin

Fieldbus

- 00 Specific for fieldbus

Specials

- 00 = Cardboard packing
- 01 = Foil packing

Cable Length

Length in meters
Standard lengths:

- m25 0.25 m
- m50 0.50 m
- 001 1 m
- 003 3 m
- 006 6 m
- 012 12 m
- 024 24 m

Wire Cross Section

Power

- 010 1.0 mm²
- 015 1.5 mm²
- 025 2.5 mm²
- 040 4.0 mm²
- 060 6.0 mm²
- 100 10.0 mm²
- 160 16.0 mm²
- 250 25.0 mm²

Feedback

- 002 0.25 mm²

Fieldbus

- 002 0.25 mm²

AKD[®]-N Cables (Decentralized)

CC N C N1 - 025 - 05M00 - 00

Cable Version

Power

- CM Motor power
- WM Washdown motor power

Feedback

- CF Motor Feedback
- WF Washdown motor feedback

Hybrid (Power + Feedback)

- CC Motor hybrid
- WC Washdown motor hybrid

Cable Type

Power

- 0 No Brake
- 1 Brake

Feedback

- C Commutating Encoder
- D EnDat/BISS digital
- E EnDat[®]/BISS
- H HIPERFACE[®]
- S SFD

Hybrid (Power + Feedback)

- S SDF + power
- J SDF3/DSL + power and brake
- N EtherCAT[®] + power

Drive Connector Type

Power

- N AKD-N (DF/DS)

Feedback

- N AKD-N (DF/DS)

Hybrid (Power + Feedback)

- C AKD-C
- N AKD-N

Motor Connector Type

- XX No connector (cut off)
- 00 Special connector

Power

- A1 AKM & C/CH connector 1.0
- A2 AKM SpeedTec[®] 1.0
- A3 AKM ytec[®] connector
- DL Linear motors

Feedback

- A1 AKM & C/CH connector 1.0
- D AKM SpeedTec[®] 1.0
- E AKM ytec[®] connector
- DL Linear motors
- E1 EnDat ext.
- E2 HIPERFACE ext.

Hybrid (Power + Feedback)

- A1 AKM & C/CH connector 1.0
- A2 AKM SpeedTec[®] 1.0
- A3 AKM itec connector
- N1 AKD-N

Specials

- 00 = Cardboard packing
- 01 = Foil packing

Cable Length

- XXMY where:
- XX meters
 - YY centimeters
- according to allowed steps (see accessories manual)

Wire Cross Section

Power

- 010 1.0 mm²
- 015 1.5 mm²
- 025 2.5 mm²

Feedback

- 002 0.25 mm²

Hybrid (Power + Feedback)

- 010 1.0 mm²
- 015 1.5 mm²
- 025 2.5 mm²

▶ AKD[®] 2G Servo Drive

The newest member of the AKD family is our most powerful yet.

Along with increased power, the AKD2G is simplified and includes integrated SafeMotion™ that increases Ease-of-Use.

The new AKD2G servo drive introduces the Kollmorgen Servo on a Chip™: A powerful compute engine that can control two axes simultaneously and up to 28 I/O. While we were at it, we streamlined the design by optimizing the AKD2G for single-cable motors.





The Benefits of AKD[®]2G Servo Drives

Flexible

- » One and two axis variants available
- » Modular design allows the user to specify only the features needed
- » Supports a variety of feedback devices. SFD3 & HIPERFACE[®] DSL standard; optional feedbacks include EnDat, BiSS, Analog Sine/Cos encoder, incremental encoder, resolver and more
- » Multiple bus choices for system optimization, including EtherCAT[®] & FSoE, CANopen[®], PROFINET[®] IRT and Ethernet/IP[™]
- » Over-voltage, current, and temperature detection provided for added dependability
- » Optional SafeMotion Monitor[™] (SMM[™]), up to SIL3/PLe
- » Dual-channel STO for each axis (up to SIL3/PLe)
- » Optionally available with coated PCBA
- » Industry-leading power density for greater flexibility in mounting
 - Fits into a 10 inch [25.4 cm] deep control panel

Easy to Use

- » Plug-and-play compatibility with Kollmorgen controls and motors
- » WorkBench GUI, acclaimed for customer experience and usability
- » Hybrid motor-power connector is optimized for single-cable motors; No adaptors, no D-sub, no splitters
- » Cage-clamp spring terminal connectors on I/O allow for fast and easy installation
- » Optically isolated I/O reduces noise and eliminates need for additional hardware

Fast

- » Accommodates changing load conditions immediately:
 - Current loop updates in 1.28 μ s, nearly 50x the speed of our nearest competitors
 - Velocity and position loops lead the market at 62.5 μ s and 125 μ s, respectively
 - » Servo on a Chip[™] includes dual-core ARM[™] A9, 800 MHz μ P, 1.5 M gates
 - » AI-based auto-tuning with a click of a button gets you started quickly
 - » Wizard-based tuning uses advanced Bode plot tool to help you efficiently manual-tune when desired
 - » Fast data acquisition with TCP/IP Ethernet service channel
-

AKD[®] 2G Servo Drive

AKD2G Means Unparalleled Connectivity

Base Model

The base model of Kollmorgen's AKD2G includes all of the performance described previously, and is optimized to interface to a single-connector motor with Kollmorgen's Smart Feedback or HIPERFACE[®] DSL. It also offers 16 I/O, 160x128-pixel graphical display, removable SD card, and your choice of motionbusses.

Extended I/O Variant

The extended I/O variant offers everything on the base model, plus I/O expansion. It adds additional 12 I/O for a total of 28 I/O. The option fit in the same package as the base model.

Two-cable feedback option

Needing support for non-single-cable feedback like EnDat, BiSS or incremental encoders? The two-cable feedback option adds a 15-pin SUB-D connector for dual cable feedback or dual-loop operation.

SafeMotion™ Monitor (SMM™)

The Extended I/O model is offered with the optional SMM. The SMM converts some of the I/O into "Safe" I/O, and allows the drive to interface safely to an FSoE master. Again, these options fit in the same package as the base model.



Dual-Axis AKD2G 480 Vac
(shown with optional feedback
and I/O expansion)

Dual-Axis AKD2G 240 Vac
(shown with optional SMM,
feedback and I/O expansion)



120/240 Vac	Continuous Current	Peak Current	Typical Shaft Power	Internal Regen		Height	Width	Depth	Depth w/ cable bend radius
	(Arms)	(Arms)	(kW)	(W)	(Ω)	mm (in)	mm (in)	mm (in)	mm (in)
AKD2G-SPx-6V03S	3	9	1	100	15	233 (9.15)	75 (2.95)	180 (7.09)	225 (8.86)
AKD2G-SPx-6V06S	6	18	2						
AKD2G-SPx-6V12S	12	30	4						
AKD2G-SPx-6V03D	3 & 3	9 & 9	1 & 1						
AKD2G-SPx-6V06D	6 & 6	18 & 18	2 & 2						

240/480 Vac	Continuous Current	Peak Current	Typical Shaft Power	Internal Regen		Height	Width	Depth	Depth w/ cable bend radius
	(Arms)	(Arms)	(kW)	(W)	(Ω)	mm (in)	mm (in)	mm (in)	mm (in)
AKD2G-SPx-7V03S	3	9	2	100	33	270 (10.6)	75 (2.95)	180 (7.09)	225 (8.86)
AKD2G-SPx-7V06S	6	18	4						
AKD2G-SPx-7V12S	12	30	8						
AKD2G-SPx-7V03D	3 & 3	9 & 9	2 & 2						
AKD2G-SPx-7V06D	6 & 6	18 & 18	4 & 4						

AKD2G Drive Connector Layout

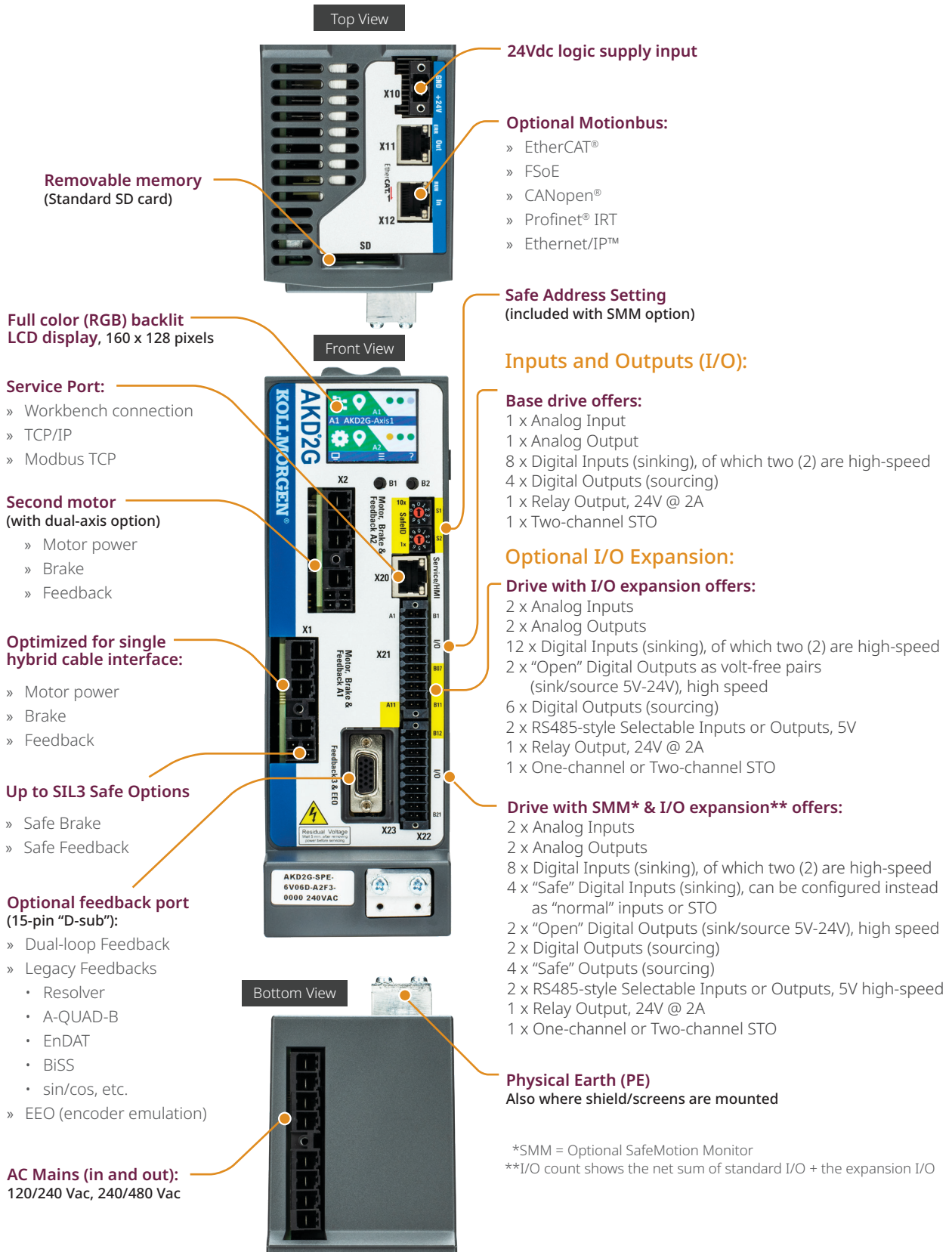

▶ AKD[®] Servo Drive

Our AKD series is a complete range of Ethernet-based servo drives that are fast, feature-rich, flexible and integrate quickly and easily into any application.

AKD ensures plug-and-play commissioning for instant, seamless access to everything in your machine. And, no matter what your application demands, AKD offers industry-leading servo performance, communication options, and power levels, all in a smaller footprint

This robust, technologically advanced family of drives delivers optimized performance when paired with our best-in-class components, producing higher quality results at greater speeds and more uptime. With Kollmorgen servo components, we can help you increase your machine's overall equipment effectiveness (OEE) by 50%.





The Benefits of AKD® Servo Drives

Optimized Performance in Seconds

- » Auto-tuning is one of the best and fastest in the industry
 - » Automatically adjusts all gains, including observers
 - » Immediate and adaptive response to dynamic loads
 - » Precise control of all motor types
 - » Compensation for stiff and compliant transmission and couplings
-

Greater Throughput and Accuracy

- » Up to 27-bit-resolution feedback yields unmatched precision and excellent repeatability
 - » Very fast settling times result from a powerful dual processor system that executes industry-leading and patent pending servo algorithms with high resolution
 - » Advanced servo techniques such as high-order observer and bi-quad filters yield industry-leading machine performance
 - » Highest bandwidth torque-and-velocity loops. Fastest digital current loop in the market
-

Easy-to-use Graphical User Interface (GUI) for Faster Commissioning and Troubleshooting

- » Six-channel real-time software oscilloscope commissions and diagnoses quickly
 - » Multi-function Bode Plot allows users to quickly evaluate performance
 - » Auto-complete of programmable commands saves looking up parameter names
 - » One-click capture and sharing of program plots and parameter settings allow you to send machine performance data instantly
 - » Widest range of programming options in the industry
-

Flexible and Scalable to Meet any Application

- » 3 to 48 Arms continuous current; 9 to 96 Arms peak
 - » Very high power density enables an extremely small package
 - » True plug-and-play with all standard Kollmorgen servo motors and actuators
 - » Supports a variety of single and multi-turn feedback devices – Smart Feedback Device (SFD/SFD3), EnDat 2.2, EnDat 2.1, BiSS, analog Sine/Cos encoder, incremental encoder, HIPERFACE®, and resolver
 - » Tightly integrated Ethernet motion buses without the need to add large hardware: EtherCAT®, SynqNet®, Modbus® TCP, EtherNet/IP™, PROFINET® RT, SERCOS® III, and CANopen®
 - » Scalable programmability from base torque-and-velocity through multi-axis master
-

AKD[®] Servo Drive

The AKD servo drive delivers cutting-edge technology and performance with one of the most compact footprints in the industry. These feature-rich drives provide a solution for nearly any application, from basic torque-and-velocity applications, to indexing, to multi-axis programmable motion with embedded Kollmorgen Automation Suite™. The versatile AKD sets the standard for power density and performance.



AKMH[™] Hygienic Stainless Steel Motors

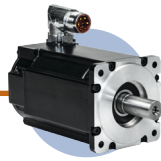

AKM & AKM[®] 2G Servo Motors

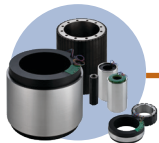

Frameless Brushless Direct Drive Motors

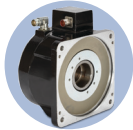

Cartridge DDR[®] Motors



Housed DDR[®] Motors

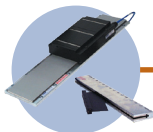

Direct Drive Linear Motors

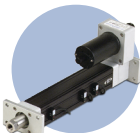

Linear Actuators

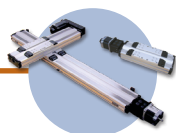

Multi-Axis Precision Tables



AKD[®]-N Decentralized Servo Drive



AKD[®] Servo Drive



Control of axes with PCMM programmable multi-axis EtherCAT[®] master

Best-in-Class Components

AKD works seamlessly with Kollmorgen motors and actuators—well-known for quality, reliability, and performance.



General Specifications

120 / 240 Vac 1 & 3 Phase (85 -265 V)	Continuous Current (Arms)	Peak Current (Arms)	Drive Continuous Output Power Capacity (Watts)	Internal Regen (Watts) (Ohms)		Height mm (in)	Width mm (in)	Depth mm (in)	Depth with Cable Bend Radius mm (in)
AKD-x00306	3	9	1100	0	0	168 (6.61)	59 (2.32)	156 (6.14)	184 (7.24)
AKD-x00606	6	18	2000	0	0	168 (6.61)	59 (2.32)	156 (6.14)	184 (7.24)
AKD-x01206	12	30	4000	100	15	196 (7.72)	78 (3.07)	187 (7.36)	215 (8.46)
AKD-x02406	24	48	8000	200	8	247 (9.72)	100 (3.94)	228 (8.98)	265 (10.43)
240/480 Vac 3 Phase (187-528 V)	Continuous Current (Arms)	Peak Current (Arms)	Drive Continuous Output Power Capacity (Watts)	Internal Regen (Watts) (Ohms)		Height mm (in)	Width mm (in)	Depth mm (in)	Depth with Cable Bend Radius mm (in)
AKD-x00307	3	9	2000	100	33	256 (10.08)	70 (2.76)	185 (7.28)	221 (8.70)
AKD-x00607	6	18	4000	100	33	256 (10.08)	70 (2.76)	185 (7.28)	221 (8.70)
AKD-x01207	12	30	8000	100	33	256 (10.08)	70 (2.76)	185 (7.28)	221 (8.70)
AKD-x02407	24	48	16,000	200	23	306 (12.01)	105 (4.13)	228 (8.98)	264 (10.39)
AKD-x04807	48	96	35,000	-	-	385 (15.16)	185 (7.28)	225 (8.86)	260 (10.23)



AKD[®] Servo Drive

Range of Coverage

When you pair the AKD servo drive with any of our Kollmorgen motors or linear actuators, you'll achieve optimized performance. From 3 to 48 Arms continuous current and 9 to 96 Arms peak current, the feature-rich AKD provides a solution for nearly any application.

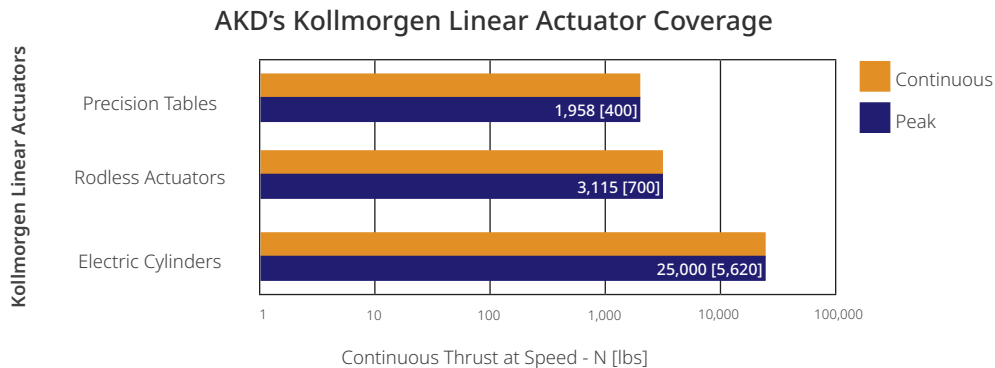
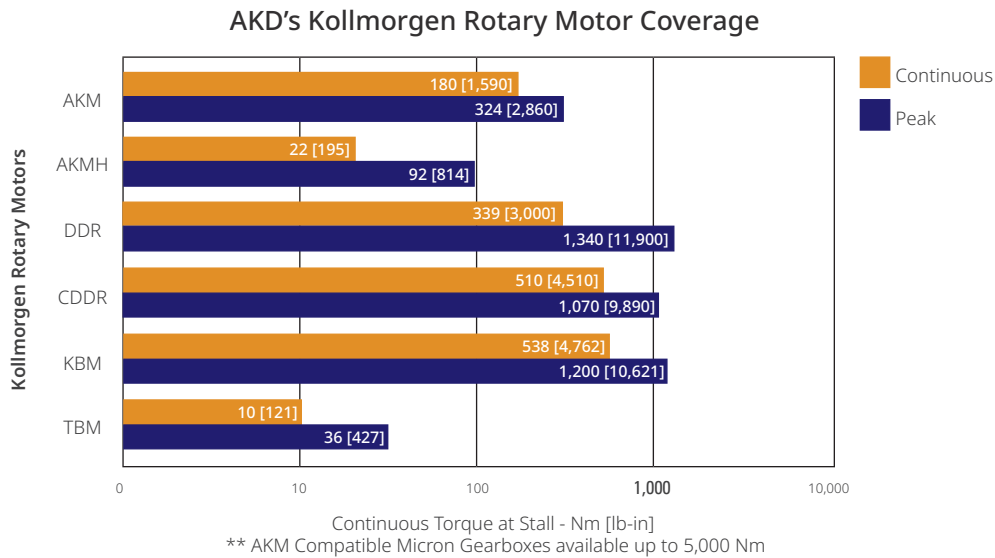
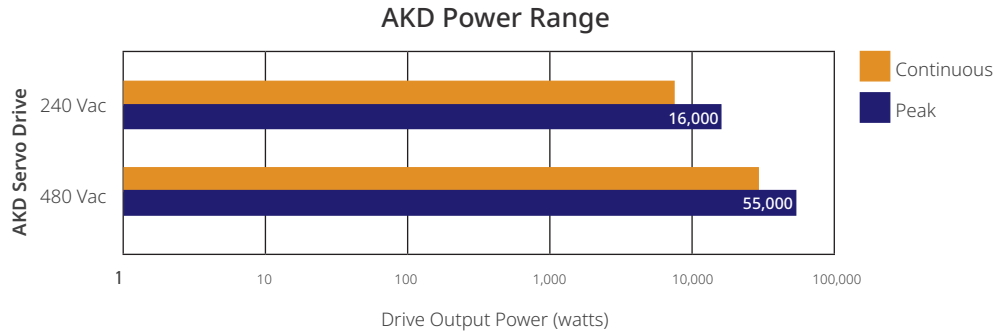

Feedback & I/O

AKD® servo drive is specifically designed with the versatility, communications, and power you need to expand machine performance and increase integration speeds. Motor set-up is plug-and-play and multiple Ethernet connectivity options provide both open and closed protocols. Online troubleshooting and data verification enable faster, bug-proof programming. And a broad power range in a smaller, compact design allows you to use these robust drives with a single interface while experiencing industry-leading, high-performance servo loops.

AKD Specifications

	Standard Drive	With I/O expansion - AKD-T only
Encoder Output or AUX Encoder Input	2.5 MHz Maximum line frequency	
Feedback	Smart Feedback Device (SFD3) and HIPERFACE DSL single cable feedback SFD, EnDat 2.1, EnDat 2.2, BiSS, analog Sine/Cos encoder, incremental encoder, HIPERFACE and resolver dual cable feedback	
Logic supply	24 Vdc	
Digital input (24 Vdc)	8 (1 dedicated to enable)	20 (1 dedicated to enable)
Digital output (24 Vdc)	3 (1 dedicated to fault relay)	13 (1 dedicated to fault relay)
Analog input (+/- 10 Vdc, 16-bit)	1	2
Analog output (+/- 10 Vdc, 16-bit)	1	2
Programmable inputs	7	19
Programmable outputs	2	12
Sink/Source inputs/outputs	Yes	Yes

AKD[®] Servo Drive Nomenclature

AKD[®]2G Servo Drive

AKD2G - S P E - 7V 06 S - A 1 F3 - 0000 - A

AKD2G Series

Format

S Servo IP20

Drive Version

P Position Indexer with motion tasks

Connectivity Option

N Analog
 E EtherCAT[®]
 C CANopen[®]
 P PROFINET[®] IRT
 I Ethernet/IP[™]

Voltage

6V 120/240 Vac 1Ø/3Ø
 7V 240/480 Vac 3Ø

Current Rating

03 3 Amp
 06 6 Amp
 12 12 Amp*

Connectors

A with connectors (except X1/X2 and X23)

Customization

0000 Standard
 A000 Coated PCBs

Options

00 Standard
 F3 X23 (Feedback 3)
 IO X22 (I/O)
 DX X22 + X23

Functional Safety

1 STO, dual channel (SIL2, PLd)
 2 STO, SS1, SDB, SBC/SBT, FSoE (up to SIL3/PLe)
 3 STO, SS1, SS2, SOS, SDB, SBC/SBT, SLS, SSR, SSM, SDI, SAR, SLA, SLI, SLP, SCA (up to SIL 3 / PLe)

Platform Revision

A MAP Revision A

Options

S Single Axis
 D Dual Axis*

* 12 amp dual axis drives are not currently available.

Note: Options shown in blue text are considered standard.

AKD® Servo Drive

AKD - B 003 06 - NB AN - 0000

AKD Series

Version

- B** Base drive
- C** Central power supply for AKD-N (requires CB extension)
- N** Decentralized drive (requires DB, DF, or DS extension)
- P** Position indexer (motion tasking)
- T** AKD BASIC Language Programmable drive (requires IC or NB extension)
- M** Multi-axis Master Drive (requires M1 or MC extension option and EC connectivity option)

Current Rating

- 003 3 Amp
- 006 6 Amp
- 010 10 kW (for AKD-C, this field refers to power)
- 012 12 Amp
- 024 24 Amp
- 048 48 Amp

Voltage

- 06 120/240 Vac 1Ø/3Ø (24 Amp drive: 240 Vac 3Ø only)
- 07 240/480 Vac 3Ø (Version C: 07 = 400/480 Vac 3Ø | Version N: 07 = 560/680 Vdc)

Variants

0000 Standard

Connectivity*

		Drive Version Availability
AN	Analog command	B, P, T
CN	CANopen®	P
EC	EtherCAT®	C, M, N, P
EI	EtherNet/IP™	P
PN	PROFINET®	P
SQ	SynqNet®	B

*Motion Tasking is included as a free upgrade with CN, EC, EI and PN

Extension

- CB** Without extension (AKD-C version only)
- DB** Hybrid motor cable (AKD-N version only)
- DF** Additional EtherCAT® port + feedback connector (AKD-N version only)
- DS** Local STO + feedback connector (AKD-N version only)
- IC** Expanded I/O version and SD card slot (AKD-T version only)
- M1** High performance multi-axis controller with industry-standard IEC 61131-3 PLC programming built-in
- MC** Standard multi-axis controller
- NB** Without extensions

Note: Options shown in blue text are considered standard.

Notes

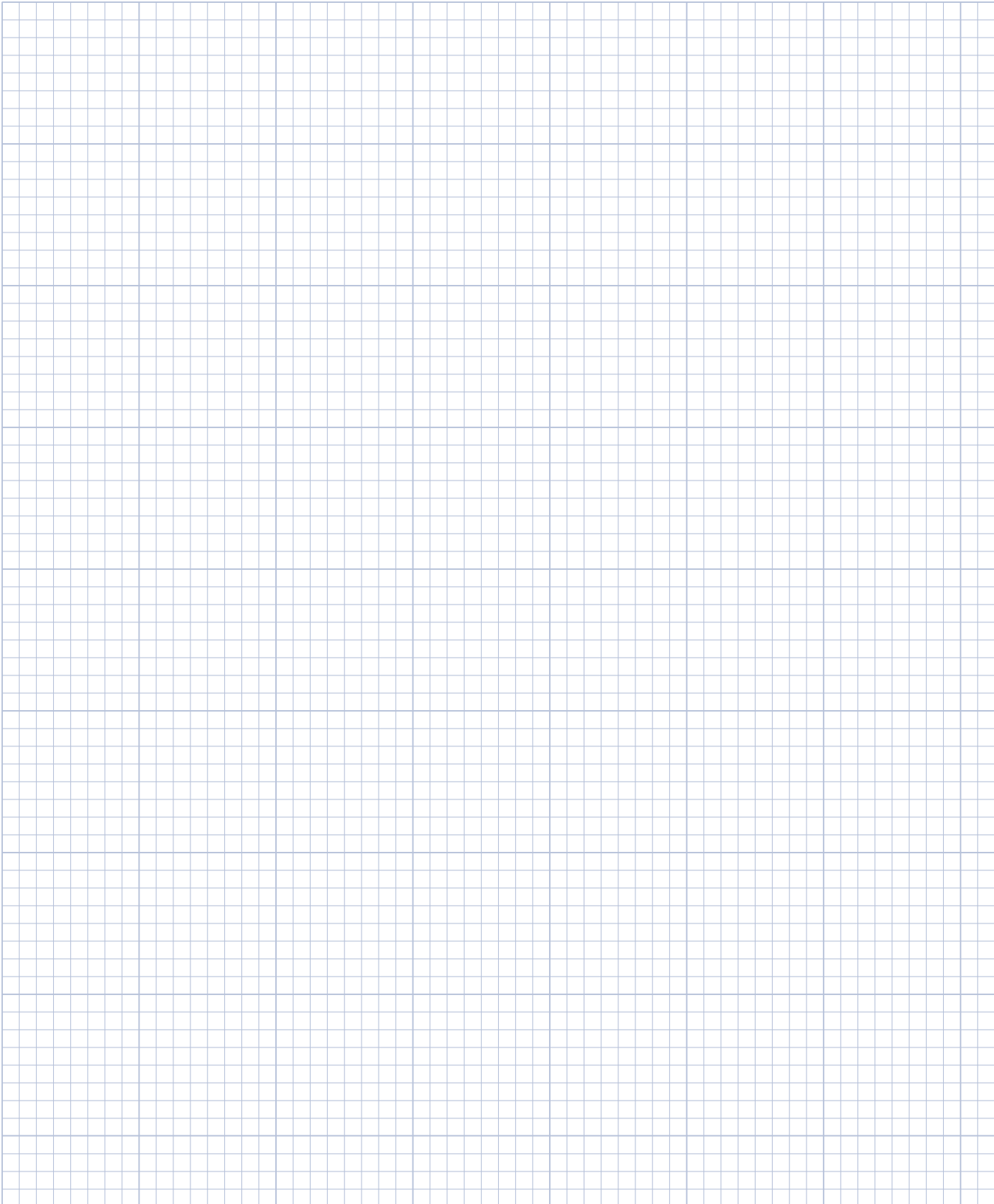

0.125 inch divisions

Kollmorgen Solutions

Automation and Motion Control

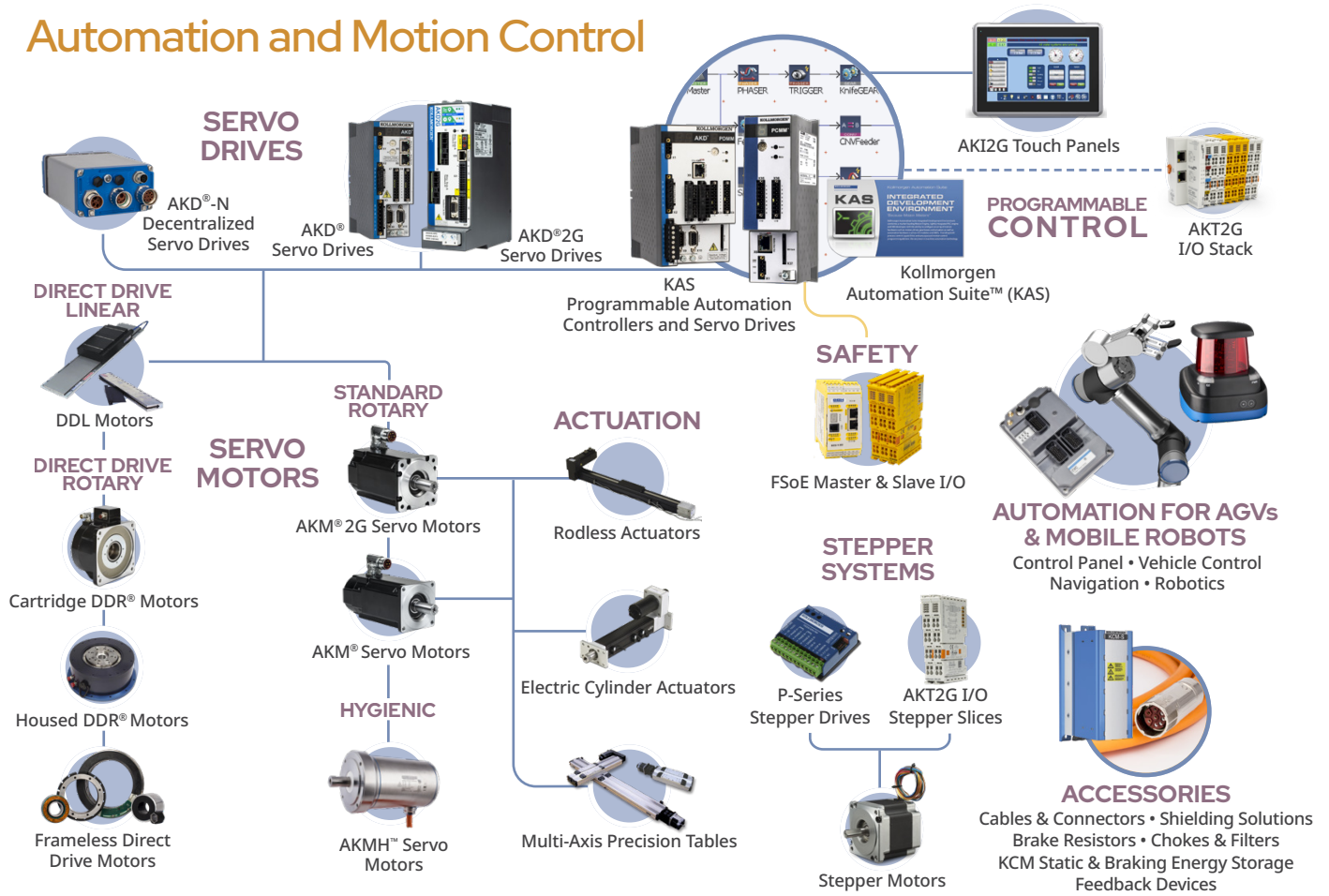

Self-Help Tools

Motioneering[®] Online

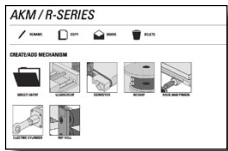

Size and select the right product for your application needs

Drawing Generator



Provides TBM/KBM/AKM 2D and 3D drawings in many popular formats

Performance Curve Generator

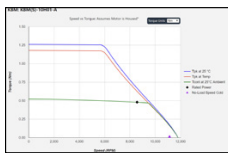

Optimize TBM/KBM/AKM windings using customer supplied environmental and drive information

Product Selector

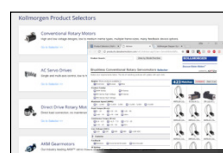

Choose the right product for your application needs

Kollmorgen Developer Network



Find answers to many key technical questions or start your own session

Stepper Optimizer

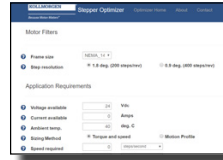

Select the most efficient stepper solution for your application

More Expertise for a More Successful Machine

Our global engineering, service and support network provides deep knowledge of all the major industries that rely on advanced motion control and automation technology. We offer world-class engineering expertise, self-service design tools, personalized field service, and easy access to our design, application and manufacturing centers in strategic locations across the globe.

About Kollmorgen

Kollmorgen has more than 70 years of motion experience, proven in the industry's highest-performing, most reliable motors, drives, linear actuators, gearheads, AGV control solutions and automation platforms. We deliver breakthrough solutions that are unmatched in performance, reliability and ease of use, giving machine builders an irrefutable marketplace advantage.

Kollmorgen is a brand of Altra Industrial Motion Corp. (NASDAQ: AIMC), a premier global designer and producer of a wide range of motion control and power transmission solutions. With engineered components and systems that provide the essential control of equipment speed, torque, positioning, and other functions, Altra products can be used in nearly any machine, process or application involving motion.

KOLLMORGEN

www.kollmorgen.com

Specifications are subject to change without notice. It is the responsibility of the product user to determine the suitability of this product for a specific application. All trademarks are the property of their respective owners

© 2022 Kollmorgen Corporation. All rights reserved