

AKM2G Servo Motor

Three-Phase AC Permanent Magnet Servo Motor

Catalog



KOLLMORGEN

A REGAL REYNORD BRAND

Kollmorgen: Your Partner, In Motion.

Every solution comes from a real understanding of the challenges facing machine designers and users.

Innovators consistently rate Kollmorgen as one of their best motion systems manufacturing partners. Whether you are looking for classic servo motors, direct-drive servo motors, stepper motors, drives & amplifiers, gearing, actuation, or multi-axis motion controllers, Kollmorgen is one of the few companies in the world that actually designs and manufactures all of these products.

Our customers are leaders in many industries such as Aerospace & Defense, Printing, Packaging & Converting, Food & Beverage Processing, Medical Imaging, In Vitro Diagnostics & Laboratory Automation, Pharmaceutical Manufacturing, Material Forming and Cutting, Oil & Gas, and Robotics. Kollmorgen is also a leader in Warehouse Automation, including complete AGV systems, software, awareness and autonomy.

Our Automation Solutions can be found on Mars and in space, ships and submarines, O&G drilling and metrology, surgical robots and laser eye surgery, even inside artificial hearts. These are just a few applications that demand high-performance and high-quality while satisfying their specific needs.

Because motion matters, it's our focus: Motion can distinctly differentiate a specific machine and deliver a marketplace advantage by increasing its performance and dramatically improving Overall Equipment Effectiveness (OEE).

High-performance motion can make your customer's machine more reliable and energy-efficient, enhance accuracy and improve operator safety. Motion also represents endless possibilities for innovation.

We've always understood this potential, and thus have kept motion at our core and in our Vision, Mission & Values, relentlessly developing products that offer precise control of torque, velocity and position accuracy in machines that rely on complex motion.

Removing the Barriers of Design, Sourcing, and Time

At Kollmorgen, we know that OEM engineers can achieve a lot more when obstacles aren't in the way. So, we clear obstacles in three important ways:

Integrating Standard and Custom Products

The optimal solution is often not clear-cut. Our application expertise allows us to modify standard products or develop totally custom solutions across our whole product portfolio so that designs can take flight.

Providing Motion Solutions, Not Just Components

As companies reduce their supplier base and focus their engineering manpower on the product design, they need a total system supplier with a wide range of integrated solutions. Kollmorgen offers complete solutions as well as motion subsystems that combine programming software, engineering services and best-in-class motion components.

Global Footprint

With direct sales, engineering support, manufacturing facilities, and distributors spanning the Americas, Europe, the Middle East, and Asia, we're close to OEMs worldwide. Our proximity helps speed delivery and lend support where and when they're needed.

Financial and Operational Stability

Kollmorgen is part of Regal Rexnord. A key driver in the growth of all Regal Rexnord segments is the Regal Rexnord Business System, which relies on the principle of "kaizen" – or continuous improvement. Using world-class tools, cross-disciplinary teams of exceptional people evaluate processes and develop plans that result in superior performance.

Kollmorgen: Your partner. In Motion.

Table of Contents

▶ AKM Servo Motor Family	4
▶ AKM2G Series Servo Motors	6
▶ AKM2G Tested with AKD Servo Drives	9
▶ AKM2G / AKD System Performance	10
▶ AKM2G Servo Motor Nomenclature	16
▶ AKM2G Servo Motor Specifications	20
Performance Data, Motor Parameters, Derate Curves, Dimensional Drawings & Data	
AKM2G-2x Series Motor Specification	20
AKM2G-3x Series Motor Specification	26
AKM2G-4x Series Motor Specification	30
AKM2G-5x Series Motor Specification	36
AKM2G-6x Series Motor Specification	42
AKM2G-7x Series Motor Specification	48
▶ AKM2G Brake Option	54
▶ AKM2G Motor Feedback Options	55
▶ AKM2G Motor Feedback Specifications	56
▶ AMK2G Motor Connector Options	60
▶ AKM2G Motor Connector Pinouts	61
▶ AKM2G Technical Guide	66
L10 Bearing Loading	66
Shaft Loading	68
Mineral-filled PTFE Teflon Shaft Seal	69
Thermal Sensor Protective Device	70
Delta Between Motor Winding and Thermal Device	71
Motor Phasing Diagram	71
Performance Curve Overview	72
▶ Motors - Copyrights, Trademarks, and Disclaimers	75
▶ Kollmorgen Solutions	77
Automation and Motion Control	77
Self-help Tools	77

AKM Servo Motor Family

Kollmorgen's AKM family of three-phase permanent magnet synchronous servo motors gives you unprecedented choice and flexibility from a wide range of standard products so you can select the best servo motor for your application. By pairing AKM servo motors with our family of plug-and-play AKD servo drives, selecting the right motion control products has never been easier. Pick from thousands of servo motor/servo drive combinations outlined in this selection guide, the AKM Servo Motor Selection Guide, or go to our website to find the best solution for your application.

Standard AKM/AKM2G servo motors and AKD servo drives offer the best of both worlds – the exact specifications of a custom solution with the faster delivery times and lower cost of a **standard catalog product**. For your truly unique motion control applications, work with our engineering team to customize a solution for your machine design. Either way, standard product or customized, we can help you choose the motion control solution that meets your exact requirements.



The Benefits of AKM2G Servo Motor

Smaller Footprint

Reduce machine space

- » For equivalent torque it is possible to use a smaller size motor than competitive motors.
 - » The range of AKM2G sizes provides for optimizing for length or flange square depending on which dimension is most critical.
 - » Use of the smaller motor saves space achieving equivalent performance in a smaller footprint machine or saving space for other machine elements.
-

Increased Torque

Higher performance

- » For a given frame size the AKM2G provides an average continuous torque increase of 30% compared to competitive motors of equivalent size.
 - » Higher torque in the same package size increases machine performance (greater throughput, move heavier loads, etc.).
-

Wider Speed Range

Faster operation

- » For many AKM2G sizes the maximum speeds are higher than competitive motors.
 - » Higher speeds ⇒ operate machines faster ⇒ greater throughput.
-

Greater Flexibility

More options to match needs

- » AKM2G is designed to support a wider array of feedback, brake, thermal sensor and shaft seal options – this greater flexibility means a higher probability of meeting application requirements with a standard product.
 - » The AKM2G design has the potential for greater CoEngineering (modification) thanks to the new housing design. With a more flexible design for CoEngineering addressing applications not covered by catalog standards is increased.
-

Higher Efficiency

Reduce energy consumption

- » AKM2G has lower equivalent resistance than competitive solutions. For equivalent motor frame sizes AKM2G will typically be more energy efficient (2-5%).
- » Energy consumption is reduced with AKM2G compared to competitors.

AKM2G Series Servo Motors

AKM2G Motors Offer Extremely High Torque Density and High Acceleration

The AKM2G high-performance motor series offers a wide range of mounting, connectivity, feedback and other options. These motors offer superb flexibility to meet application needs with:

- 6 frame sizes (58 to 192 mm)
- 23 frame-stack length combinations
- More than 70 standard windings



Features

Torque

0.64 to 72 Nm maximum continuous torque (5.6 to 640 lb-in) in 23 frame/stack combinations. Specific torques are often available from multiple frame sizes to optimize mounting and inertia matching capabilities.

Speed

Speeds up to 8000 rpm meet high speed application requirements. Windings tailored to lower speeds are also available.

Voltage

AKM2G motors can be applied to all standard global voltages. Windings are specifically tailored to work with drives powered by 120, 240, 400 or 480 Vac. AKM2G motors can be operated on DC voltages and voltages of less than 120Vac; for these applications please contact Kollmorgen Customer Support for assistance with sizing and selection

Feedback

AKM2G motors include Resolver, Absolute Digital Encoders, Comcoders, or SFD (Smart Feedback Device) feedback options to meet specific application requirements.

Mounting

Multiple mounting standards are available to meet common International standards.

Smoothness

Smooth performance results from low-cog, low-harmonic distortion magnetic designs.

Connectivity

Rotatable IP65 connectors, or straight connectors are both available to provide flexibility. Single connectors/plugs (combined power and feedback) are also available to minimize motor and cable cost (SFD and Absolute Digital Encoders only).

Thermal

Windings are rated conservatively at 100°C rise over a 40°C ambient while using 155 °C (class F) insulation materials. Motors meet applicable UL, CSA, and CE requirements and include thermistors.

Additional Options:

- Holding brakes
- Shaft sealing options available
- Feedback devices
- Shaft and mounting variations
- Custom windings
- Thermal sensor options



Kollmorgen Cables Offer the Complete Solution

Kollmorgen offers complete cable solutions for connecting drives and motors. This includes static, low cost cable sets for simple applications to high bend, high flex, hybrid cables that combine feedback and power in one cable. Not sure which cable offering would best suit your needs? No problem. See the Kollmorgen 2G Cable Guide, or Kollmorgen Customer Support is available to discuss cable options and what makes the most sense for your machine.

AKM2G represents the latest evolution of the industry leading AKM motor product family.

With average continuous torque increases of 30%, OEMs and users can achieve substantial machine performance increases without increasing the size of the motor.

The improved torque density allows a smaller motor to be used which reduces the machine footprint without sacrificing performance.

- » Extensive Selection of Feedback options to match application and performance requirements
- » Shaft, mounting and connector options for optimal flexibility
- » Holding Brake option

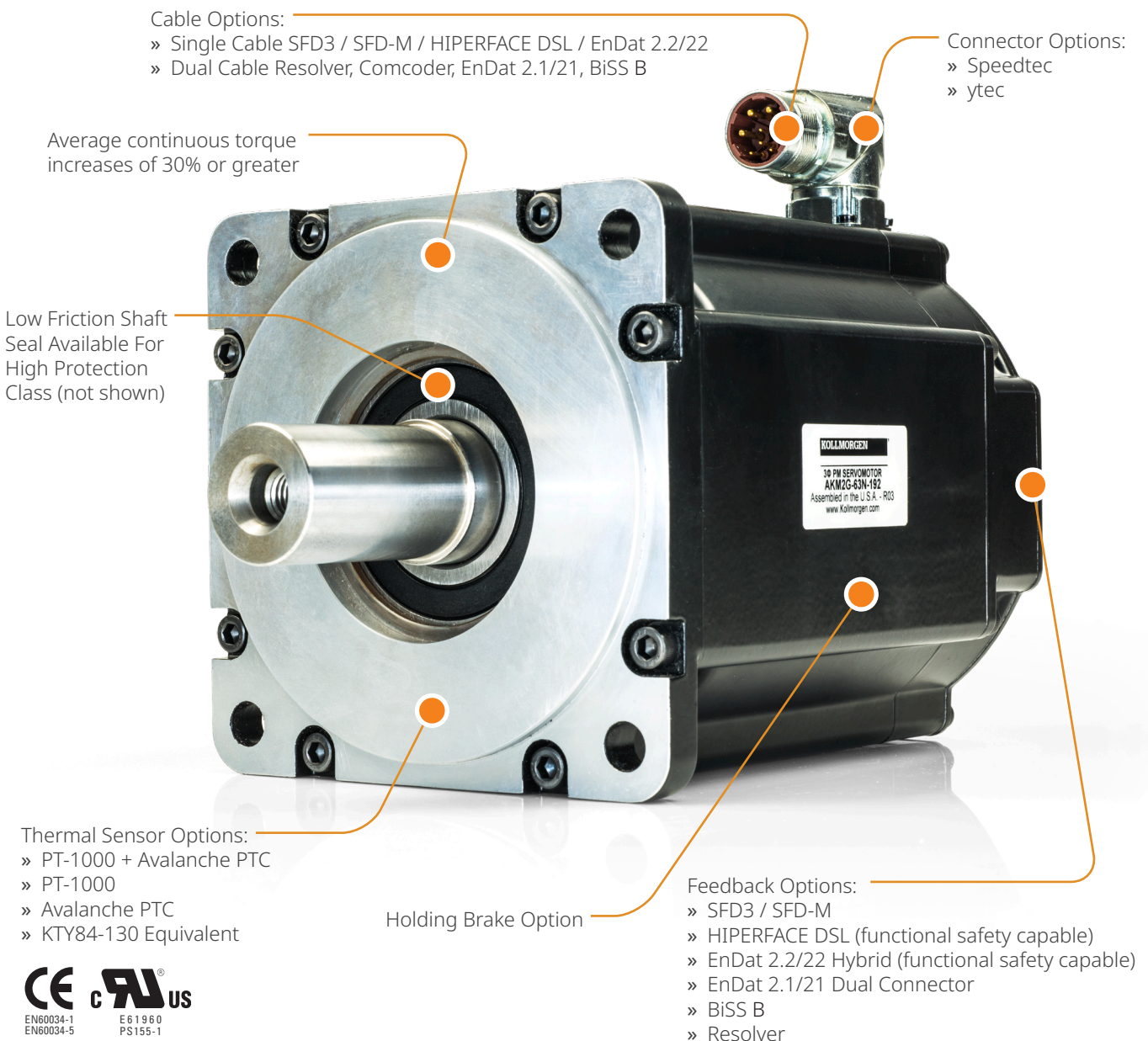

AKM2G Series Servo Motors

Higher Power Density with Increased Performance and Efficiency



Available with
low voltage windings*

AKM2G-2x

Flange: 58 mm
Power: 0.206 - 1.16 kW
Max Speed: 8000 RPM
Stacks: 4

The smallest AKM2G. For dual cable connection with resolvers the compact ytec connector is used.



Available with
low voltage windings*

AKM2G-3x

Flange: 72 mm
Power: 0.175 - 1.77 kW
Max Speed: 8000 RPM
Stacks: 3

Available with motor-mounted rotatable single or dual cable connectors (feedback dependent).



Available with
low voltage windings*

AKM2G-4x

Flange: 88 mm
Power: 0.267 - 2.85 kW
Max Speed: 6000 RPM
Stacks: 4

Available with motor-mounted rotatable single or dual cable connectors (feedback dependent).



AKM2G-5x

Flange: 114 mm
Power: 0.78 - 5.28 kW
Max Speed: 6000 RPM
Stacks: 4

Available with motor-mounted rotatable single or dual cable connectors (feedback dependent).

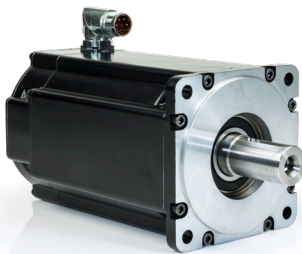

AKM2G-6x

Flange: 142 mm
Power: 1.56 - 7.79 kW
Max Speed: 6000 RPM
Stacks: 4

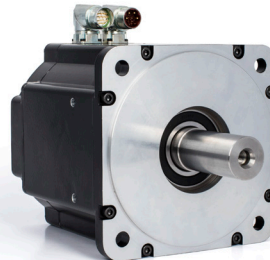

AKM2G-7x

Flange: 192 mm
Power: 2.42 - 11.8 kW
Max Speed: 6000 RPM
Stacks: 4

Provides torque levels previously seen only in larger size motors.
Offered with motor-mounted rotatable single or dual cable connectors (feedback dependent), including optional holding brakes.

*See the [AKM2G Low Voltage Selection Guide](#)



The lineup of AKM2G and AKM servo motors, with some exclusions, offer a motor-mounted rotatable single connector for Kollmorgen's exclusive third generation Smart Feedback Device (SFD3), innovative multi-turn Smart Feedback Device (SFD-M) and industry standard multi-turn digital encoders like HIPERFACE DSL and EnDat, as well as incorporating optional brake support.

AKM2G Tested with AKD Servo Drives

The AKM2G performance data and curves in this guide were acquired using Kollmorgen's AKD family of servo drives. Please go to <https://www.kollmorgen.com/en-us/products/drives/servo/servo-drives> or contact Kollmorgen Customer Support for detailed specifications and to learn how pairing them with the AKM2G servo motor can optimized system performance.



AKD Product Family

Parameter	AKD2G	AKD	AKD BASIC	AKD PDMM	AKD-N/AKD-C
Base I/O	12 digital 2 analog	11 digital 2 analog	11 digital 2 analog	17 digital 2 analog	5 digital
Expansion I/O ¹	8 digital 2 analog *Drive size is the same	No	20 digital 2 analog *adds 30 mm to the drive width for drives up to 12A	Up to 1000+ remote I/O via EtherCAT	No
Safe I/O	2 digital inputs for Safety option 1 4 digital inputs for SafeMotion options	No	No	No	No
SafeMotion ²	Yes	STO only	STO only	STO only	STO only
Optimized for single cable ³	Yes	No	No	No	Yes
Continuous current limit ⁴	24A	48A	48A	48A	12A
Connectivity ⁵	Analog, EtherCAT, CANopen, Profinet IRT, Ethernet/IP, TCP/IP, Modbus/TCP	Analog, EtherCAT, CANopen, Profinet RT, Ethernet/IP, TCP/IP, Modbus/TCP	Analog	EtherCAT, CANopen, Profinet RT, Ethernet/IP, TCP/IP, Modbus/TCP	EtherCAT
Axis Configuration	single or dual	single	single	single	single
Drive-resident controller	No	No	No	Yes	No
Programmability	parameterized, 2 axes control loops, action table	parameterized	parameterized, BASIC programmable	parameterized, IEC 61131-3 via PLCopen or Pipe Network	parameterized
Graphical Display	160x128-pixel display	2 digit LED	2 digit LED	3 digit LED	Status LED
Removeable Memory ⁶	Yes	No	Yes	Yes	No
System Architecture	Centralized	Centralized	Centralized	Centralized	Decentralized
IP Rating	IP20	IP20	IP20	IP20	IP67 (AKD-N)

Notes:

- 1: Add EtherCAT multi-axis master, PCMM, to the AKD drive family to enable remote I/O expansion via EtherCAT. PCMM controller functionality is built into the PDMM
- 2: SafeMotion includes FSoE, STO, SS1, SS2, SOS, SDB, SBC/SBT, SLS, SSR, SSM, SDI, SAR, SLA, SLI, SLP, SCA up to SIL3 / PLe
- 3: Single cable optimized means one single cable for power & motor feedback with 1 connector at motor end and 1 connector at drive end
- 4: Higher power variants under development in some models. Consult factory for availability.
- 5: Consult factory on connectivity options for AKD2G.
- 6: Optional integrated SD card for easy backup and drive cloning

AKM2G/AKD Family System Performance

System Performance – AKM2G Servo Motors driven by AKD2G and AKD Servo Drives

AKM2G Servo Motor ¹	AKD2G/AKD Servo Drive	Frame Size mm	Continuous Torque Tcs Nm (lb-in)	Peak Torque Tps Nm (lb-in)	Rated Speed Nrtd RPM	Max System Speed ² RPM	Power Prtd watts	Inertia (Jm) Kg-cm ² (lb-in-s ²)
AKM2G-21D	AKD2G-SPx-6V03x/AKD-x00306	58	0.641 (5.67)	2.50 (22.1)	4300	8000	266	0.093 (8.23E-05)
AKM2G-21E	AKD2G-SPx-6V03x/AKD-x00306	58	0.645 (5.71)	2.10 (18.6)	5600	8000	339	0.093 (8.23E-05)
AKM2G-21E	AKD2G-SPx-6V06x/AKD-x00606	58	0.645 (5.71)	2.53 (22.4)	5600	8000	339	0.093 (8.23E-05)
AKM2G-21G	AKD2G-SPx-6V06x/AKD-x00606	58	0.652 (5.77)	2.56 (22.7)	8000	8000	458	0.093 (8.23E-05)
AKM2G-22C	AKD2G-SPx-6V03x/AKD-x00306	58	1.12 (9.89)	4.11 (36.4)	1800	8000	204	0.155 (1.37E-04)
AKM2G-22D	AKD2G-SPx-6V03x/AKD-x00306	58	1.12 (9.91)	4.16 (36.8)	2700	8000	300	0.155 (1.37E-04)
AKM2G-22E	AKD2G-SPx-6V03x/AKD-x00306	58	1.12 (9.93)	3.40 (30.1)	3600	8000	392	0.155 (1.37E-04)
AKM2G-22E	AKD2G-SPx-6V06x/AKD-x00606	58	1.12 (9.93)	4.39 (38.9)	3600	8000	392	0.155 (1.37E-04)
AKM2G-23D	AKD2G-SPx-6V03x/AKD-x00306	58	1.50 (13.2)	5.85 (51.8)	1800	8000	272	0.217 (1.92E-04)
AKM2G-23E	AKD2G-SPx-6V03x/AKD-x00306	58	1.50 (13.2)	4.54 (40.2)	2700	8000	398	0.217 (1.92E-04)
AKM2G-23E	AKD2G-SPx-6V06x/AKD-x00606	58	1.50 (13.2)	5.84 (51.7)	2700	8000	398	0.217 (1.92E-04)
AKM2G-23F	AKD2G-SPx-6V06x/AKD-x00606	58	1.52 (13.4)	5.94 (52.6)	4000	8000	576	0.217 (1.92E-04)
AKM2G-24D	AKD2G-SPx-6V03x/AKD-x00306	58	1.82 (16.1)	7.13 (63.1)	1500	8000	277	0.279 (2.47E-04)
AKM2G-24E	AKD2G-SPx-6V03x/AKD-x00306	58	1.83 (16.2)	5.57 (49.3)	2300	8000	417	0.279 (2.47E-04)
AKM2G-24E	AKD2G-SPx-6V06x/AKD-x00606	58	1.83 (16.2)	7.16 (63.4)	2300	8000	417	0.279 (2.47E-04)
AKM2G-24F	AKD2G-SPx-6V06x/AKD-x00606	58	1.86 (16.4)	7.24 (64.1)	3400	8000	603	0.279 (2.47E-04)
AKM2G-31C	AKD2G-SPx-6V03x/AKD-x00306	72	1.68 (14.9)	4.54 (40.2)	1000	8000	175	0.426 (3.77E-04)
AKM2G-31D	AKD2G-SPx-6V03x/AKD-x00306	72	1.69 (15.0)	6.01 (53.2)	1500	8000	263	0.426 (3.77E-04)
AKM2G-31E	AKD2G-SPx-6V03x/AKD-x00306	72	1.72 (15.2)	4.90 (43.4)	2300	8000	404	0.426 (3.77E-04)
AKM2G-31E	AKD2G-SPx-6V06x/AKD-x00606	72	1.72 (15.2)	6.06 (53.6)	2300	8000	404	0.426 (3.77E-04)
AKM2G-32E	AKD2G-SPx-6V03x/AKD-x00306	72	2.83 (25.0)	8.68 (76.8)	1300	8000	378	0.813 (7.20E-04)
AKM2G-32E	AKD2G-SPx-6V06x/AKD-x00606	72	2.83 (25.0)	10.3 (91.5)	1300	8000	378	0.813 (7.20E-04)
AKM2G-32G	AKD2G-SPx-6V06x/AKD-x00606	72	2.93 (25.9)	10.6 (94.3)	2300	8000	680	0.813 (7.20E-04)
AKM2G-33G	AKD2G-SPx-6V06x/AKD-x00606	72	3.84 (34.0)	14.4 (128)	1600	8000	622	1.20 (1.06E-03)
AKM2G-33H	AKD2G-SPx-6V06x/AKD-x00606	72	3.89 (34.5)	11.6 (102)	2250	8000	866	1.20 (1.06E-03)
AKM2G-33H	AKD2G-SPx-6V12x/AKD-x01206	72	3.89 (34.5)	14.6 (129)	2250	8000	866	1.20 (1.06E-03)
AKM2G-41D	AKD2G-SPx-6V03x/AKD-x00306	88	2.87 (25.4)	7.20 (63.7)	900	6000	267	0.774 (6.85E-04)
AKM2G-41E	AKD2G-SPx-6V03x/AKD-x00306	88	2.89 (25.5)	6.61 (58.5)	1200	6000	357	0.774 (6.85E-04)
AKM2G-41E	AKD2G-SPx-6V06x/AKD-x00606	88	2.89 (25.5)	7.26 (64.3)	1200	6000	357	0.774 (6.85E-04)
AKM2G-41G	AKD2G-SPx-6V06x/AKD-x00606	88	2.89 (25.6)	7.25 (64.2)	2100	6000	613	0.774 (6.85E-04)
AKM2G-42H	AKD2G-SPx-6V06x/AKD-x00606	88	5.17 (45.7)	12.9 (114)	1500	6000	790	1.36 (1.20E-03)
AKM2G-42H	AKD2G-SPx-6V12x/AKD-x01206	88	5.17 (45.7)	14.4 (127)	1500	6000	790	1.36 (1.20E-03)
AKM2G-43I	AKD2G-SPx-6V12x/AKD-x01206	88	7.07 (62.6)	21.1 (187)	1400	6000	1000	1.95 (1.73E-03)
AKM2G-44H	AKD2G-SPx-6V06x/AKD-x00606	88	8.59 (76.0)	22.4 (199)	900	6000	790	2.53 (2.24E-03)
AKM2G-44H	AKD2G-SPx-6V12x/AKD-x01206	88	8.59 (76.0)	27.0 (239)	900	6000	790	2.53 (2.24E-03)
AKM2G-44J	AKD2G-SPx-6V12x/AKD-x01206	88	8.59 (76.0)	26.9 (238)	1200	6000	1040	2.53 (2.24E-03)
AKM2G-51H	AKD2G-SPx-6V06x/AKD-x00606	114	6.86 (60.7)	15.7 (139)	1100	6000	780	2.52 (2.23E-03)
AKM2G-51I	AKD2G-SPx-6V06x/AKD-x00606	114	6.45 (57.1)	15.3 (135)	1200	6000	850	2.52 (2.23E-03)
AKM2G-51I	AKD2G-SPx-6V12x/AKD-x01206	114	6.88 (60.9)	15.7 (139)	1200	6000	850	2.52 (2.23E-03)
AKM2G-51K	AKD2G-SPx-6V12x/AKD-x01206	114	6.89 (60.9)	15.6 (138)	2100	6000	1440	2.52 (2.23E-03)
AKM2G-52K	AKD2G-SPx-6V12x/AKD-x01206	114	12.1 (107)	28.9 (256)	1200	6000	1470	4.58 (4.05E-03)
AKM2G-52L	AKD-x02406	114	11.4 (101)	24.8 (220)	1500	6000	1800	4.58 (4.05E-03)
AKM2G-52L	AKD-x02406	114	12.1 (107)	28.9 (256)	1500	6000	1800	4.58 (4.05E-03)
AKM2G-53L	AKD2G-SPx-6V12x/AKD-x01206	114	15.4 (136)	34.8 (308)	1100	6000	1800	6.64 (5.88E-03)
AKM2G-53L	AKD-x02406	114	16.3 (144)	41.4 (366)	1100	6000	1800	6.64 (5.88E-03)
AKM2G-53M	AKD2G-SPx-6V12x/AKD-x01206	114	13.6 (120)	31.5 (279)	1300	6000	2090	6.64 (5.88E-03)
AKM2G-53M	AKD-x02406	114	16.2 (144)	41.5 (367)	1300	6000	2090	6.64 (5.88E-03)
AKM2G-54M	AKD2G-SPx-6V12x/AKD-x01206	114	16.4 (145)	39.4 (349)	1100	6000	2220	8.70 (7.70E-03)
AKM2G-54M	AKD-x02406	114	20.3 (180)	54.7 (484)	1100	6000	2220	8.70 (7.70E-03)
AKM2G-54N	AKD-x02406	114	20.3 (179)	53.9 (477)	1200	6000	2400	8.70 (7.70E-03)
AKM2G-62L	AKD2G-SPx-6V12x/AKD-x01206	142	15.4 (136)	33.7 (298)	1000	6000	1560	9.10 (8.05E-03)
AKM2G-62L	AKD-x02406	142	15.4 (136)	37.4 (331)	1000	6000	1560	9.10 (8.05E-03)
AKM2G-62M	AKD-x02406	142	15.3 (135)	37.4 (331)	1300	6000	1990	9.10 (8.05E-03)
AKM2G-63M	AKD-x02406	142	21.6 (191)	54.5 (482)	1000	6000	2190	13.0 (1.15E-02)
AKM2G-63N	AKD-x02406	142	21.6 (191)	52.5 (465)	1100	6000	2390	13.0 (1.15E-02)
AKM2G-64N	AKD-x02406	142	27.2 (241)	64.8 (574)	900	6000	2470	16.9 (1.50E-02)
AKM2G-71N	AKD-x02406	192	23.0 (204)	49.3 (436)	1050	6000	2420	25.9 (2.29E-02)
AKM2G-71P	AKD-x02406	192	23.3 (206)	46.4 (410)	1300	6000	2980	25.9 (2.29E-02)

¹ For complete AKM2G model nomenclature, refer to pages 16 and 17.

² Max mechanical speeds: 8000 RPM for AKM2G-2,3 and 6000 RPM for AKM2G-4, 5, 6, 7.

System Performance – AKM2G Servo Motors driven by AKD2G and AKD Servo Drives

AKM2G Servo Motor ^①	AKD2G/AKD Servo Drive	Frame Size mm	Continuous Torque Tcs Nm (lb-in)	Peak Torque Tps Nm (lb-in)	Rated Speed Nrt'd RPM	Max System Speed ^② RPM	Power Prtd watts	Inertia (Jm) Kg-cm ² (lb-in-s ²)
AKM2G-21D	AKD2G-SPx-6V03x/AKD-x00306	58	0.640 (5.66)	2.50 (22.1)	8000	8000	449	0.093 (8.23E-05)
AKM2G-21E	AKD2G-SPx-6V03x/AKD-x00306	58	0.644 (5.70)	2.10 (18.6)	8000	8000	449	0.093 (8.23E-05)
AKM2G-21E	AKD2G-SPx-6V06x/AKD-x00606	58	0.644 (5.70)	2.53 (22.4)	8000	8000	449	0.093 (8.23E-05)
AKM2G-22C	AKD2G-SPx-6V03x/AKD-x00306	58	1.12 (9.88)	4.37 (38.7)	4200	8000	448	0.155 (1.37E-04)
AKM2G-22D	AKD2G-SPx-6V03x/AKD-x00306	58	1.12 (9.89)	4.16 (36.8)	6100	8000	616	0.155 (1.37E-04)
AKM2G-22E	AKD2G-SPx-6V03x/AKD-x00306	58	1.12 (9.92)	3.40 (30.1)	8000	8000	759	0.155 (1.37E-04)
AKM2G-22E	AKD2G-SPx-6V06x/AKD-x00606	58	1.12 (9.92)	4.39 (38.9)	8000	8000	759	0.155 (1.37E-04)
AKM2G-23D	AKD2G-SPx-6V03x/AKD-x00306	58	1.49 (13.2)	5.85 (51.8)	4100	8000	579	0.217 (1.92E-04)
AKM2G-23E	AKD2G-SPx-6V03x/AKD-x00306	58	1.49 (13.2)	4.54 (40.2)	5800	8000	772	0.217 (1.92E-04)
AKM2G-23E	AKD2G-SPx-6V06x/AKD-x00606	58	1.49 (13.2)	5.84 (51.7)	5800	8000	772	0.217 (1.92E-04)
AKM2G-23F	AKD2G-SPx-6V06x/AKD-x00606	58	1.51 (13.4)	5.94 (52.6)	8000	8000	980	0.217 (1.92E-04)
AKM2G-24D	AKD2G-SPx-6V03x/AKD-x00306	58	1.82 (16.1)	7.13 (63.1)	3500	8000	607	0.279 (2.47E-04)
AKM2G-24E	AKD2G-SPx-6V03x/AKD-x00306	58	1.83 (16.2)	5.57 (49.3)	4900	8000	808	0.279 (2.47E-04)
AKM2G-24E	AKD2G-SPx-6V06x/AKD-x00606	58	1.83 (16.2)	7.16 (63.4)	4900	8000	808	0.279 (2.47E-04)
AKM2G-24F	AKD2G-SPx-6V06x/AKD-x00606	58	1.85 (16.4)	7.24 (64.1)	7200	8000	1080	0.279 (2.47E-04)
AKM2G-31C	AKD2G-SPx-6V03x/AKD-x00306	72	1.68 (14.9)	5.99 (53.0)	2400	8000	412	0.426 (3.77E-04)
AKM2G-31D	AKD2G-SPx-6V03x/AKD-x00306	72	1.69 (15.0)	6.01 (53.2)	3500	8000	594	0.426 (3.77E-04)
AKM2G-31E	AKD2G-SPx-6V03x/AKD-x00306	72	1.71 (15.2)	4.90 (43.4)	5000	8000	832	0.426 (3.77E-04)
AKM2G-31E	AKD2G-SPx-6V06x/AKD-x00606	72	1.71 (15.2)	6.06 (53.6)	5000	8000	832	0.426 (3.77E-04)
AKM2G-32D	AKD2G-SPx-6V03x/AKD-x00306	72	2.82 (25.0)	10.4 (91.8)	2200	8000	628	0.813 (7.20E-04)
AKM2G-32E	AKD2G-SPx-6V03x/AKD-x00306	72	2.82 (24.9)	8.68 (76.8)	2900	8000	811	0.813 (7.20E-04)
AKM2G-32E	AKD2G-SPx-6V06x/AKD-x00606	72	2.82 (24.9)	10.3 (91.5)	2900	8000	811	0.813 (7.20E-04)
AKM2G-32G	AKD2G-SPx-6V06x/AKD-x00606	72	2.92 (25.8)	10.6 (94.3)	4700	8000	1280	0.813 (7.20E-04)
AKM2G-33E	AKD2G-SPx-6V03x/AKD-x00306	72	3.87 (34.3)	11.2 (99.4)	2300	8000	878	1.20 (1.06E-03)
AKM2G-33E	AKD2G-SPx-6V06x/AKD-x00606	72	3.87 (34.3)	14.6 (129)	2300	8000	878	1.20 (1.06E-03)
AKM2G-33G	AKD2G-SPx-6V06x/AKD-x00606	72	3.83 (33.9)	14.4 (128)	3350	8000	1210	1.20 (1.06E-03)
AKM2G-33H	AKD2G-SPx-6V06x/AKD-x00606	72	3.88 (34.3)	11.6 (102)	4600	8000	1540	1.20 (1.06E-03)
AKM2G-33H	AKD2G-SPx-6V12x/AKD-x01206	72	3.88 (34.3)	14.6 (129)	4600	8000	1540	1.20 (1.06E-03)
AKM2G-41D	AKD2G-SPx-6V03x/AKD-x00306	88	2.86 (25.3)	7.20 (63.7)	2100	6000	607	0.774 (6.85E-04)
AKM2G-41E	AKD2G-SPx-6V03x/AKD-x00306	88	2.88 (25.5)	6.61 (58.5)	2700	6000	773	0.774 (6.85E-04)
AKM2G-41E	AKD2G-SPx-6V06x/AKD-x00606	88	2.88 (25.5)	7.26 (64.3)	2700	6000	773	0.774 (6.85E-04)
AKM2G-41G	AKD2G-SPx-6V06x/AKD-x00606	88	2.88 (25.5)	7.25 (64.2)	4500	6000	1210	0.774 (6.85E-04)
AKM2G-42D	AKD2G-SPx-6V03x/AKD-x00306	88	5.06 (44.8)	14.3 (127)	1200	6000	620	1.36 (1.20E-03)
AKM2G-42E	AKD2G-SPx-6V03x/AKD-x00306	88	5.10 (45.1)	12.6 (112)	1600	6000	830	1.36 (1.20E-03)
AKM2G-42E	AKD2G-SPx-6V06x/AKD-x00606	88	5.10 (45.1)	14.4 (127)	1600	6000	830	1.36 (1.20E-03)
AKM2G-42H	AKD2G-SPx-6V06x/AKD-x00606	88	5.15 (45.6)	12.9 (114)	3200	6000	1560	1.36 (1.20E-03)
AKM2G-42H	AKD2G-SPx-6V12x/AKD-x01206	88	5.15 (45.6)	14.4 (128)	3200	6000	1560	1.36 (1.20E-03)
AKM2G-43G	AKD2G-SPx-6V06x/AKD-x00606	88	7.00 (62.0)	21.0 (186)	1900	6000	1320	1.95 (1.73E-03)
AKM2G-43I	AKD2G-SPx-6V12x/AKD-x01206	88	7.05 (62.4)	21.1 (187)	3000	6000	1950	1.95 (1.73E-03)
AKM2G-44E	AKD2G-SPx-6V03x/AKD-x00306	88	8.50 (75.2)	22.0 (195)	900	6000	783	2.53 (2.24E-03)
AKM2G-44E	AKD2G-SPx-6V06x/AKD-x00606	88	8.51 (75.3)	26.9 (238)	900	6000	783	2.53 (2.24E-03)
AKM2G-44H	AKD2G-SPx-6V06x/AKD-x00606	88	8.56 (75.8)	22.4 (199)	2000	6000	1660	2.53 (2.24E-03)
AKM2G-44H	AKD2G-SPx-6V12x/AKD-x01206	88	8.56 (75.8)	27.0 (239)	2000	6000	1660	2.53 (2.24E-03)
AKM2G-44J	AKD2G-SPx-6V12x/AKD-x01206	88	8.56 (75.8)	26.9 (238)	2600	6000	2060	2.53 (2.24E-03)
AKM2G-51H	AKD2G-SPx-6V06x/AKD-x00606	114	6.85 (60.6)	15.7 (139)	2400	6000	1620	2.52 (2.23E-03)
AKM2G-51I	AKD2G-SPx-6V06x/AKD-x00606	114	6.45 (57.1)	15.3 (135)	2700	6000	1800	2.52 (2.23E-03)
AKM2G-51I	AKD2G-SPx-6V12x/AKD-x01206	114	6.86 (60.7)	15.7 (139)	2700	6000	1800	2.52 (2.23E-03)
AKM2G-51K	AKD2G-SPx-6V12x/AKD-x01206	114	6.86 (60.7)	15.6 (138)	4500	6000	2720	2.52 (2.23E-03)
AKM2G-52H	AKD2G-SPx-6V06x/AKD-x00606	114	11.4 (101)	28.1 (249)	1500	6000	1800	4.58 (4.05E-03)
AKM2G-52H	AKD2G-SPx-6V12x/AKD-x01206	114	12.0 (107)	29.0 (257)	1500	6000	1800	4.58 (4.05E-03)
AKM2G-52K	AKD2G-SPx-6V12x/AKD-x01206	114	12.1 (107)	28.9 (256)	2500	6000	2830	4.58 (4.05E-03)
AKM2G-52L	AKD2G-SPx-6V12x/AKD-x01206	114	11.4 (101)	24.8 (220)	3200	6000	3420	4.58 (4.05E-03)
AKM2G-52L	AKD-x02406	114	12.0 (106)	28.9 (256)	3200	6000	3420	4.58 (4.05E-03)
AKM2G-53H	AKD2G-SPx-6V06x/AKD-x00606	114	16.3 (144)	41.8 (370)	1000	6000	1650	6.64 (5.88E-03)
AKM2G-53L	AKD2G-SPx-6V12x/AKD-x01206	114	15.4 (136)	34.8 (308)	2400	6000	3530	6.64 (5.88E-03)
AKM2G-53L	AKD-x02406	114	16.2 (144)	41.4 (366)	2400	6000	3530	6.64 (5.88E-03)
AKM2G-53M	AKD2G-SPx-6V12x/AKD-x01206	114	13.6 (120)	31.5 (279)	2800	6000	3970	6.64 (5.88E-03)
AKM2G-53M	AKD-x02406	114	16.2 (143)	41.5 (367)	2800	6000	3970	6.64 (5.88E-03)

① For complete AKM2G model nomenclature, refer to pages 16 and 17.
 ② Max mechanical speeds: 8000 RPM for AKM2G-2,3 and 6000 RPM for AKM2G-4, 5, 6, 7.

AKM2G/AKD Family System Performance

System Performance – AKM2G Servo Motors driven by AKD2G and AKD Servo Drives

AKM2G Servo Motor ¹	AKD2G/AKD Servo Drive	Frame Size mm	Continuous Torque Tcs Nm (lb-in)	Peak Torque Tps Nm (lb-in)	Rated Speed Nrtd RPM	Max System Speed ² RPM	Power Prtd watts	Inertia (Jm) Kg-cm ² (lb-in-s ²)	
240 V	AKM2G-54L	AKD2G-SPx-6V12x/AKD-x01206	114	20.3 (179)	52.3 (463)	1600	6000	3090	8.70 (7.70E-03)
	AKM2G-54L	AKD-x02406	114	20.3 (179)	54.8 (485)	1600	6000	3090	8.70 (7.70E-03)
	AKM2G-54M	AKD2G-SPx-6V12x/AKD-x01206	114	16.4 (145)	39.4 (349)	2300	6000	4130	8.70 (7.70E-03)
	AKM2G-54M	AKD-x02406	114	20.2 (179)	54.7 (484)	2300	6000	4130	8.70 (7.70E-03)
	AKM2G-54N	AKD-x02406	114	20.2 (179)	53.9 (477)	2600	6000	4490	8.70 (7.70E-03)
	AKM2G-62K	AKD2G-SPx-6V12x/AKD-x01206	142	15.4 (136)	37.6 (332)	1700	6000	2560	9.10 (8.05E-03)
	AKM2G-62L	AKD2G-SPx-6V12x/AKD-x01206	142	15.3 (135)	33.7 (298)	2200	6000	3190	9.10 (8.05E-03)
	AKM2G-62L	AKD-x02406	142	15.3 (135)	37.4 (331)	2200	6000	3190	9.10 (8.05E-03)
	AKM2G-62M	AKD-x02406	142	15.2 (135)	37.4 (331)	2800	6000	3850	9.10 (8.05E-03)
	AKM2G-63K	AKD2G-SPx-6V12x/AKD-x01206	142	21.7 (192)	54.8 (485)	1300	6000	2790	13.0 (1.15E-02)
	AKM2G-63M	AKD-x02406	142	21.5 (191)	54.5 (482)	2100	6000	4210	13.0 (1.15E-02)
	AKM2G-63N	AKD-x02406	142	21.5 (190)	52.5 (465)	2300	6000	4510	13.0 (1.15E-02)
	AKM2G-63N	AKD-x04807	142	21.5 (190)	54.5 (483)	2300	6000	4510	13.0 (1.15E-02)
	AKM2G-64L	AKD2G-SPx-6V12x/AKD-x01206	142	27.2 (241)	63.9 (566)	1200	6000	3230	16.9 (1.50E-02)
	AKM2G-64L	AKD-x02406	142	27.2 (241)	70.7 (626)	1200	6000	3230	16.9 (1.50E-02)
	AKM2G-64M	AKD-x02406	142	27.1 (240)	70.5 (624)	1700	6000	4370	16.9 (1.50E-02)
	AKM2G-64N	AKD-x02406	142	27.1 (240)	64.8 (574)	2000	6000	4980	16.9 (1.50E-02)
	AKM2G-64N	AKD-x04807	142	27.1 (240)	70.3 (623)	2000	6000	4980	16.9 (1.50E-02)
	AKM2G-65L	AKD2G-SPx-6V12x/AKD-x01206	142	31.7 (280)	73.0 (646)	1100	6000	3580	20.8 (1.84E-02)
	AKM2G-65L	AKD-x02406	142	32.9 (291)	86.8 (768)	1100	6000	3580	20.8 (1.84E-02)
	AKM2G-65M	AKD-x02406	142	32.8 (291)	86.8 (768)	1400	6000	4440	20.8 (1.84E-02)
	AKM2G-65N	AKD-x02406	142	33.0 (292)	75.8 (671)	1700	6000	5250	20.8 (1.84E-02)
	AKM2G-65N	AKD-x04807	142	33.0 (292)	87.0 (770)	1700	6000	5250	20.8 (1.84E-02)
	AKM2G-71L	AKD2G-SPx-6V12x/AKD-x01206	192	22.7 (201)	49.2 (436)	1500	6000	3340	25.9 (2.29E-02)
	AKM2G-71L	AKD-x02406	192	23.0 (203)	49.5 (438)	1500	6000	3340	25.9 (2.29E-02)
	AKM2G-71N	AKD-x02406	192	22.9 (203)	49.3 (436)	2200	6000	4580	25.9 (2.29E-02)
	AKM2G-71P	AKD-x02406	192	23.2 (205)	46.3 (410)	2700	6000	5370	25.9 (2.29E-02)
	AKM2G-71P	AKD-x04807	192	23.2 (205)	49.7 (440)	2700	6000	5370	25.9 (2.29E-02)
	AKM2G-72L	AKD2G-SPx-6V12x/AKD-x01206	192	39.5 (349)	87.6 (775)	900	6000	3640	46.8 (4.14E-02)
	AKM2G-72L	AKD-x02406	192	40.7 (361)	89.3 (790)	900	6000	3640	46.8 (4.14E-02)
	AKM2G-72N	AKD-x02406	192	41.5 (367)	90.3 (799)	1400	6000	5480	46.8 (4.14E-02)
	AKM2G-72P	AKD-x02406	192	41.0 (363)	82.9 (734)	1600	6000	6050	46.8 (4.14E-02)
	AKM2G-72P	AKD-x04807	192	41.0 (363)	89.5 (792)	1600	6000	6050	46.8 (4.14E-02)
AKM2G-73N	AKD-x02406	192	58.3 (516)	129 (1150)	900	6000	5150	67.7 (5.99E-02)	
AKM2G-73Q	AKD-x02406	192	49.9 (442)	95.3 (843)	1500	6000	7850	67.7 (5.99E-02)	
AKM2G-73Q	AKD-x04807	192	57.7 (510)	128 (1130)	1500	6000	7850	67.7 (5.99E-02)	
AKM2G-74P	AKD-x02406	192	72.8 (644)	141 (1250)	1000	6000	6960	88.6 (7.84E-02)	
AKM2G-74P	AKD-x04807	192	72.8 (644)	164 (1460)	1000	6000	6960	88.6 (7.84E-02)	
AKM2G-74Q	AKD-x02406	192	59.6 (527)	115 (1020)	1250	6000	8370	88.6 (7.84E-02)	
AKM2G-74Q	AKD-x04807	192	72.5 (642)	164 (1450)	1250	6000	8370	88.6 (7.84E-02)	
AKM2G-74R	AKD-x04807	192	72.2 (639)	163 (1440)	1450	6000	9340	88.6 (7.84E-02)	
400 V	AKM2G-21D	AKD2G-SPx-7V03x/AKD-x00307	58	0.638 (5.65)	2.50 (22.1)	8000	8000	440	0.093 (8.23E-05)
	AKM2G-22C	AKD2G-SPx-7V03x/AKD-x00307	58	1.11 (9.87)	4.37 (38.7)	7500	8000	721	0.155 (1.37E-04)
	AKM2G-22D	AKD2G-SPx-7V03x/AKD-x00307	58	1.12 (9.88)	4.16 (36.8)	8000	8000	746	0.155 (1.37E-04)
	AKM2G-23D	AKD2G-SPx-7V03x/AKD-x00307	58	1.49 (13.2)	5.85 (51.8)	7300	8000	913	0.217 (1.92E-04)
	AKM2G-23E	AKD2G-SPx-7V03x/AKD-x00307	58	1.49 (13.2)	4.54 (40.2)	8000	8000	953	0.217 (1.92E-04)
	AKM2G-23E	AKD2G-SPx-7V06x/AKD-x00607	58	1.49 (13.2)	5.84 (51.7)	8000	8000	953	0.217 (1.92E-04)
	AKM2G-24D	AKD2G-SPx-7V03x/AKD-x00307	58	1.82 (16.1)	7.13 (63.1)	6100	8000	948	0.279 (2.47E-04)
	AKM2G-24E	AKD2G-SPx-7V03x/AKD-x00307	58	1.83 (16.2)	5.57 (49.3)	8000	8000	1120	0.279 (2.47E-04)
	AKM2G-24E	AKD2G-SPx-7V06x/AKD-x00607	58	1.83 (16.2)	7.16 (63.4)	8000	8000	1120	0.279 (2.47E-04)
	AKM2G-24F	AKD2G-SPx-7V06x/AKD-x00607	58	1.85 (16.4)	7.24 (64.1)	8000	8000	1090	0.279 (2.47E-04)
	AKM2G-31C	AKD2G-SPx-7V03x/AKD-x00307	72	1.68 (14.9)	5.99 (53.0)	4300	8000	713	0.426 (3.77E-04)
	AKM2G-31D	AKD2G-SPx-7V03x/AKD-x00307	72	1.69 (14.9)	6.00 (53.1)	6100	8000	972	0.426 (3.77E-04)
	AKM2G-31E	AKD2G-SPx-7V03x/AKD-x00307	72	1.71 (15.1)	4.90 (43.4)	8000	8000	1200	0.426 (3.77E-04)
	AKM2G-31E	AKD2G-SPx-7V06x/AKD-x00607	72	1.71 (15.1)	6.06 (53.6)	8000	8000	1200	0.426 (3.77E-04)
	AKM2G-32D	AKD2G-SPx-7V03x/AKD-x00307	72	2.82 (24.9)	10.4 (91.8)	3900	8000	1060	0.813 (7.20E-04)
	AKM2G-32E	AKD2G-SPx-7V03x/AKD-x00307	72	2.81 (24.9)	8.68 (76.8)	5000	8000	1290	0.813 (7.20E-04)
	AKM2G-32E	AKD2G-SPx-7V06x/AKD-x00607	72	2.81 (24.9)	10.3 (91.5)	5000	8000	1290	0.813 (7.20E-04)

¹ For complete AKM2G model nomenclature, refer to pages 16 and 17.

² Max mechanical speeds: 8000 RPM for AKM2G-2,3 and 6000 RPM for AKM2G-4, 5, 6, 7.

System Performance – AKM2G Servo Motors driven by AKD2G and AKD Servo Drives

AKM2G Servo Motor ¹	AKD2G/AKD Servo Drive	Frame Size mm	Continuous Torque Tcs Nm (lb-in)	Peak Torque Tps Nm (lb-in)	Rated Speed Nrtd RPM	Max System Speed ² RPM	Power Prtd watts	Inertia (Jm) Kg-cm ² (lb-in-s ²)
AKM2G-32G	AKD2G-SPx-7V06x/AKD-x00607	72	2.90 (25.7)	10.6 (94.3)	7600	8000	1720	0.813 (7.20E-04)
AKM2G-33E	AKD2G-SPx-7V03x/AKD-x00307	72	3.86 (34.2)	11.2 (99.4)	4000	8000	1390	1.20 (1.06E-03)
AKM2G-33E	AKD2G-SPx-7V06x/AKD-x00607	72	3.86 (34.2)	14.6 (129)	4000	8000	1390	1.20 (1.06E-03)
AKM2G-33G	AKD2G-SPx-7V06x/AKD-x00607	72	3.82 (33.8)	14.4 (128)	5800	8000	1720	1.20 (1.06E-03)
AKM2G-33H	AKD2G-SPx-7V06x/AKD-x00607	72	3.85 (34.1)	11.6 (102)	8000	8000	1570	1.20 (1.06E-03)
AKM2G-33H	AKD2G-SPx-7V12x/AKD-x01207	72	3.84 (34.0)	14.6 (129)	8000	8000	1570	1.20 (1.06E-03)
AKM2G-41D	AKD2G-SPx-7V03x/AKD-x00307	88	2.86 (25.3)	7.20 (63.7)	3800	6000	1040	0.774 (6.85E-04)
AKM2G-41E	AKD2G-SPx-7V03x/AKD-x00307	88	2.87 (25.4)	6.61 (58.5)	4800	6000	1270	0.774 (6.85E-04)
AKM2G-41E	AKD2G-SPx-7V06x/AKD-x00607	88	2.87 (25.4)	7.26 (64.3)	4800	6000	1270	0.774 (6.85E-04)
AKM2G-41G	AKD2G-SPx-7V06x/AKD-x00607	88	2.87 (25.4)	7.25 (64.2)	6000	6000	1430	0.774 (6.85E-04)
AKM2G-42D	AKD2G-SPx-7V03x/AKD-x00307	88	5.05 (44.7)	14.3 (127)	2100	6000	1050	1.36 (1.20E-03)
AKM2G-42E	AKD2G-SPx-7V03x/AKD-x00307	88	5.09 (45.0)	12.6 (112)	2700	6000	1330	1.36 (1.20E-03)
AKM2G-42E	AKD2G-SPx-7V06x/AKD-x00607	88	5.09 (45.0)	14.4 (127)	2700	6000	1330	1.36 (1.20E-03)
AKM2G-42H	AKD2G-SPx-7V06x/AKD-x00607	88	5.13 (45.4)	12.9 (114)	5600	6000	2270	1.36 (1.20E-03)
AKM2G-42H	AKD2G-SPx-7V12x/AKD-x01207	88	5.12 (45.3)	14.4 (128)	5600	6000	2270	1.36 (1.20E-03)
AKM2G-43D	AKD2G-SPx-7V03x/AKD-x00307	88	6.97 (61.7)	20.7 (183)	1600	6000	1120	1.95 (1.73E-03)
AKM2G-43G	AKD2G-SPx-7V06x/AKD-x00607	88	6.98 (61.8)	21.0 (186)	3200	6000	2050	1.95 (1.73E-03)
AKM2G-43I	AKD2G-SPx-7V12x/AKD-x01207	88	7.00 (61.9)	21.1 (187)	5300	6000	2680	1.95 (1.73E-03)
AKM2G-44E	AKD2G-SPx-7V03x/AKD-x00307	88	8.49 (75.1)	22.0 (195)	1700	6000	1420	2.53 (2.24E-03)
AKM2G-44E	AKD2G-SPx-7V06x/AKD-x00607	88	8.49 (75.1)	26.9 (238)	1700	6000	1420	2.53 (2.24E-03)
AKM2G-44H	AKD2G-SPx-7V06x/AKD-x00607	88	8.53 (75.5)	22.4 (199)	3500	6000	2560	2.53 (2.24E-03)
AKM2G-44H	AKD2G-SPx-7V12x/AKD-x01207	88	8.51 (75.3)	27.0 (239)	3500	6000	2560	2.53 (2.24E-03)
AKM2G-44J	AKD2G-SPx-7V12x/AKD-x01207	88	8.50 (75.2)	26.9 (238)	4500	6000	2840	2.53 (2.24E-03)
AKM2G-51H	AKD2G-SPx-7V06x/AKD-x00607	114	6.83 (60.4)	15.7 (139)	4200	6000	2590	2.52 (2.23E-03)
AKM2G-51I	AKD2G-SPx-7V06x/AKD-x00607	114	6.45 (57.1)	15.3 (135)	4600	6000	2770	2.52 (2.23E-03)
AKM2G-51I	AKD2G-SPx-7V12x/AKD-x01207	114	6.83 (60.5)	15.7 (139)	4600	6000	2770	2.52 (2.23E-03)
AKM2G-51K	AKD2G-SPx-7V12x/AKD-x01207	114	6.81 (60.3)	15.6 (138)	6000	6000	2930	2.52 (2.23E-03)
AKM2G-52H	AKD2G-SPx-7V06x/AKD-x00607	114	11.4 (101)	28.1 (249)	2700	6000	3020	4.58 (4.05E-03)
AKM2G-52H	AKD2G-SPx-7V12x/AKD-x01207	114	12.0 (106)	29.0 (257)	2700	6000	3020	4.58 (4.05E-03)
AKM2G-52K	AKD2G-SPx-7V12x/AKD-x01207	114	12.0 (106)	28.9 (256)	4400	6000	4140	4.58 (4.05E-03)
AKM2G-52L	AKD2G-SPx-7V12x/AKD-x01207	114	11.4 (101)	24.8 (220)	5600	6000	4350	4.58 (4.05E-03)
AKM2G-52L	AKD2G-SPx-7V24x/AAKD-x02407	114	12.0 (106)	28.9 (256)	5600	6000	4350	4.58 (4.05E-03)
AKM2G-53H	AKD2G-SPx-7V06x/AKD-x00607	114	16.3 (144)	41.8 (370)	1800	6000	2810	6.64 (5.88E-03)
AKM2G-53L	AKD2G-SPx-7V12x/AKD-x01207	114	15.4 (136)	34.8 (308)	4200	6000	4770	6.64 (5.88E-03)
AKM2G-53L	AKD2G-SPx-7V24x/AKD-x02407	114	16.1 (143)	41.4 (366)	4200	6000	4770	6.64 (5.88E-03)
AKM2G-53M	AKD2G-SPx-7V12x/AKD-x01207	114	13.6 (120)	31.5 (279)	4800	6000	4900	6.64 (5.88E-03)
AKM2G-53M	AKD2G-SPx-7V24x/AKD-x02407	114	16.1 (142)	41.5 (367)	4800	6000	4900	6.64 (5.88E-03)
AKM2G-54L	AKD2G-SPx-7V12x/AKD-x01207	114	20.1 (178)	52.3 (463)	2800	6000	4660	8.70 (7.70E-03)
AKM2G-54L	AKD2G-SPx-7V24x/AKD-x02407	114	20.2 (179)	54.8 (485)	2800	6000	4660	8.70 (7.70E-03)
AKM2G-54M	AKD2G-SPx-7V12x/AKD-x01207	114	16.4 (145)	39.4 (349)	3900	6000	5280	8.70 (7.70E-03)
AKM2G-54M	AKD2G-SPx-7V24x/AKD-x02407	114	20.1 (178)	54.7 (484)	3900	6000	5280	8.70 (7.70E-03)
AKM2G-54N	AKD2G-SPx-7V24x/AKD-x02407	114	20.0 (177)	53.9 (477)	4500	6000	5200	8.70 (7.70E-03)
AKM2G-62K	AKD2G-SPx-7V12x/AKD-x01207	142	15.3 (135)	37.6 (332)	3000	6000	4050	9.10 (8.05E-03)
AKM2G-62L	AKD2G-SPx-7V12x/AKD-x01207	142	15.2 (135)	33.7 (298)	3900	6000	4700	9.10 (8.05E-03)
AKM2G-62L	AKD2G-SPx-7V24x/AKD-x02407	142	15.2 (135)	37.4 (331)	3900	6000	4700	9.10 (8.05E-03)
AKM2G-62M	AKD2G-SPx-7V24x/AKD-x02407	142	15.1 (134)	37.4 (331)	5000	6000	5030	9.10 (8.05E-03)
AKM2G-63K	AKD2G-SPx-7V12x/AKD-x01207	142	21.6 (191)	54.8 (485)	2200	6000	4350	13.0 (1.15E-02)
AKM2G-63M	AKD2G-SPx-7V24x/AKD-x02407	142	21.4 (190)	54.5 (482)	3600	6000	5880	13.0 (1.15E-02)
AKM2G-63N	AKD2G-SPx-7V24x/AKD-x02407	142	21.4 (189)	52.5 (465)	4100	6000	6070	13.0 (1.15E-02)
AKM2G-63N	AKD-x04807	142	21.4 (189)	54.5 (483)	4100	6000	6070	13.0 (1.15E-02)
AKM2G-64L	AKD2G-SPx-7V12x/AKD-x01207	142	27.1 (240)	63.9 (566)	2100	6000	5150	16.9 (1.50E-02)
AKM2G-64L	AKD2G-SPx-7V24x/AKD-x02407	142	27.1 (240)	70.7 (626)	2100	6000	5150	16.9 (1.50E-02)
AKM2G-64M	AKD2G-SPx-7V24x/AKD-x02407	142	27.0 (239)	70.5 (624)	3000	6000	6450	16.9 (1.50E-02)
AKM2G-64N	AKD2G-SPx-7V24x/AKD-x02407	142	26.9 (238)	64.8 (574)	3400	6000	6720	16.9 (1.50E-02)
AKM2G-64N	AKD-x04807	142	26.9 (238)	70.3 (623)	3400	6000	6720	16.9 (1.50E-02)
AKM2G-65L	AKD2G-SPx-7V12x/AKD-x01207	142	31.7 (280)	73.0 (646)	1900	6000	5670	20.8 (1.84E-02)
AKM2G-65L	AKD2G-SPx-7V24x/AKD-x02407	142	32.7 (290)	86.8 (768)	1900	6000	5670	20.8 (1.84E-02)
AKM2G-65M	AKD2G-SPx-7V24x/AKD-x02407	142	32.7 (289)	86.8 (768)	2400	6000	6710	20.8 (1.84E-02)

¹ For complete AKM2G model nomenclature, refer to pages 16 and 17.
² Max mechanical speeds: 8000 RPM for AKM2G-2,3 and 6000 RPM for AKM2G-4, 5, 6, 7.

AKM2G/AKD Family System Performance

System Performance – AKM2G Servo Motors driven by AKD2G and AKD Servo Drives

AKM2G Servo Motor ^①	AKD2G/AKD Servo Drive	Frame Size mm	Continuous Torque Tcs Nm (lb-in)	Peak Torque Tps Nm (lb-in)	Rated Speed Nrt ^② RPM	Max System Speed ^② RPM	Power Prtd watts	Inertia (Jm) Kg-cm ² (lb-in-s ²)	
400 V	AKM2G-65N	AKD2G-SPx-7V24x/AKD-x02407	142	32.8 (290)	75.8 (671)	3100	6000	7670	20.8 (1.84E-02)
	AKM2G-65N	AKD-x04807	142	32.8 (290)	87.0 (770)	3100	6000	7670	20.8 (1.84E-02)
	AKM2G-71L	AKD2G-SPx-7V12x/AKD-x01207	192	22.7 (201)	49.2 (436)	2600	6000	5180	25.9 (2.29E-02)
	AKM2G-71L	AKD2G-SPx-7V24x/AKD-x02407	192	22.9 (203)	49.5 (438)	2600	6000	5180	25.9 (2.29E-02)
	AKM2G-71N	AKD2G-SPx-7V24x/AKD-x02407	192	22.8 (202)	49.3 (436)	4000	6000	6390	25.9 (2.29E-02)
	AKM2G-71P	AKD2G-SPx-7V24x/AKD-x02407	192	23.0 (204)	46.3 (410)	4900	6000	6170	25.9 (2.29E-02)
	AKM2G-71P	AKD-x04807	192	23.0 (204)	49.7 (440)	4900	6000	6170	25.9 (2.29E-02)
	AKM2G-72L	AKD2G-SPx-7V12x/AKD-x01207	192	39.5 (349)	87.6 (775)	1550	6000	5860	46.8 (4.14E-02)
	AKM2G-72L	AKD2G-SPx-7V24x/AKD-x02407	192	40.6 (359)	89.3 (790)	1550	6000	5860	46.8 (4.14E-02)
	AKM2G-72N	AKD2G-SPx-7V24x/AKD-x02407	192	41.2 (365)	90.3 (799)	2400	6000	8030	46.8 (4.14E-02)
	AKM2G-72P	AKD2G-SPx-7V24x/AKD-x02407	192	40.7 (361)	82.9 (733)	2800	6000	8510	46.8 (4.14E-02)
	AKM2G-72P	AKD-x04807	192	40.7 (361)	89.5 (792)	2800	6000	8510	46.8 (4.14E-02)
	AKM2G-73L	AKD2G-SPx-7V12x/AKD-x01207	192	56.6 (501)	127 (1130)	1050	6000	5770	67.7 (5.99E-02)
	AKM2G-73N	AKD2G-SPx-7V24x/AKD-x02407	192	58.0 (513)	129 (1150)	1600	6000	8290	67.7 (5.99E-02)
	AKM2G-73Q	AKD2G-SPx-7V24x/AKD-x02407	192	49.9 (442)	95.2 (843)	2600	6000	10600	67.7 (5.99E-02)
	AKM2G-73Q	AKD-x04807	192	57.2 (506)	128 (1130)	2600	6000	10600	67.7 (5.99E-02)
	AKM2G-74P	AKD2G-SPx-7V24x/AKD-x02407	192	72.3 (640)	141 (1250)	1700	6000	10300	88.6 (7.84E-02)
	AKM2G-74P	AKD-x04807	192	72.3 (640)	164 (1460)	1700	6000	10300	88.6 (7.84E-02)
	AKM2G-74Q	AKD2G-SPx-7V24x/AKD-x02407	192	59.6 (527)	115 (1020)	2200	6000	11700	88.6 (7.84E-02)
	AKM2G-74Q	AKD-x04807	192	71.9 (637)	164 (1450)	2200	6000	11700	88.6 (7.84E-02)
AKM2G-74R	AKD-x04807	192	71.5 (633)	163 (1440)	2500	6000	11800	88.6 (7.84E-02)	
480 V	AKM2G-21D	AKD2G-SPx-7V03x/AKD-x00307	58	0.638 (5.64)	2.50 (22.1)	8000	8000	436	0.093 (8.23E-05)
	AKM2G-22C	AKD2G-SPx-7V03x/AKD-x00307	58	1.11 (9.86)	4.37 (38.7)	8000	8000	751	0.155 (1.37E-04)
	AKM2G-22D	AKD2G-SPx-7V03x/AKD-x00307	58	1.11 (9.87)	4.16 (36.8)	8000	8000	737	0.155 (1.37E-04)
	AKM2G-23D	AKD2G-SPx-7V03x/AKD-x00307	58	1.49 (13.2)	5.85 (51.8)	8000	8000	963	0.217 (1.92E-04)
	AKM2G-23E	AKD2G-SPx-7V03x/AKD-x00307	58	1.49 (13.2)	4.54 (40.2)	8000	8000	937	0.217 (1.92E-04)
	AKM2G-23E	AKD2G-SPx-7V06x/AKD-x00607	58	1.49 (13.2)	5.84 (51.7)	8000	8000	937	0.217 (1.92E-04)
	AKM2G-24D	AKD2G-SPx-7V03x/AKD-x00307	58	1.82 (16.1)	7.13 (63.1)	7400	8000	1070	0.279 (2.47E-04)
	AKM2G-24E	AKD2G-SPx-7V03x/AKD-x00307	58	1.82 (16.1)	5.57 (49.3)	8000	8000	1100	0.279 (2.47E-04)
	AKM2G-24E	AKD2G-SPx-7V06x/AKD-x00607	58	1.82 (16.1)	7.16 (63.4)	8000	8000	1100	0.279 (2.47E-04)
	AKM2G-24F	AKD2G-SPx-7V06x/AKD-x00607	58	1.85 (16.3)	7.24 (64.1)	8000	8000	1060	0.279 (2.47E-04)
	AKM2G-31C	AKD2G-SPx-7V03x/AKD-x00307	72	1.68 (14.8)	5.99 (53.0)	5200	8000	844	0.426 (3.77E-04)
	AKM2G-31D	AKD2G-SPx-7V03x/AKD-x00307	72	1.68 (14.9)	6.00 (53.1)	7300	8000	1120	0.426 (3.77E-04)
	AKM2G-31E	AKD2G-SPx-7V03x/AKD-x00307	72	1.70 (15.1)	4.90 (43.4)	8000	8000	1160	0.426 (3.77E-04)
	AKM2G-31E	AKD2G-SPx-7V06x/AKD-x00607	72	1.70 (15.1)	6.06 (53.6)	8000	8000	1160	0.426 (3.77E-04)
	AKM2G-32D	AKD2G-SPx-7V03x/AKD-x00307	72	2.81 (24.9)	10.4 (91.8)	4700	8000	1230	0.813 (7.20E-04)
	AKM2G-32E	AKD2G-SPx-7V03x/AKD-x00307	72	2.80 (24.8)	8.68 (76.8)	6100	8000	1490	0.813 (7.20E-04)
	AKM2G-32E	AKD2G-SPx-7V06x/AKD-x00607	72	2.80 (24.8)	10.3 (91.5)	6100	8000	1490	0.813 (7.20E-04)
	AKM2G-33E	AKD2G-SPx-7V03x/AKD-x00307	72	3.86 (34.1)	11.2 (99.4)	4800	8000	1580	1.20 (1.06E-03)
	AKM2G-33E	AKD2G-SPx-7V06x/AKD-x00607	72	3.86 (34.1)	14.6 (129)	4800	8000	1580	1.20 (1.06E-03)
	AKM2G-33G	AKD2G-SPx-7V06x/AKD-x00607	72	3.81 (33.7)	14.4 (128)	7000	8000	1770	1.20 (1.06E-03)
	AKM2G-41D	AKD2G-SPx-7V03x/AKD-x00307	88	2.85 (25.3)	7.20 (63.7)	4600	6000	1220	0.774 (6.85E-04)
	AKM2G-41E	AKD2G-SPx-7V03x/AKD-x00307	88	2.87 (25.4)	6.61 (58.5)	5900	6000	1470	0.774 (6.85E-04)
	AKM2G-41E	AKD2G-SPx-7V06x/AKD-x00607	88	2.87 (25.4)	7.26 (64.3)	5900	6000	1470	0.774 (6.85E-04)
	AKM2G-41G	AKD2G-SPx-7V06x/AKD-x00607	88	2.86 (25.3)	7.25 (64.2)	6000	6000	1370	0.774 (6.85E-04)
	AKM2G-42D	AKD2G-SPx-7V03x/AKD-x00307	88	5.04 (44.6)	14.3 (127)	2600	6000	1280	1.36 (1.20E-03)
	AKM2G-42E	AKD2G-SPx-7V03x/AKD-x00307	88	5.08 (45.0)	12.6 (112)	3300	6000	1580	1.36 (1.20E-03)
	AKM2G-42E	AKD2G-SPx-7V06x/AKD-x00607	88	5.08 (45.0)	14.4 (127)	3300	6000	1580	1.36 (1.20E-03)
	AKM2G-42H	AKD2G-SPx-7V06x/AKD-x00607	88	5.12 (45.3)	12.9 (114)	6000	6000	2230	1.36 (1.20E-03)
	AKM2G-42H	AKD2G-SPx-7V12x/AKD-x01207	88	5.10 (45.2)	14.4 (128)	6000	6000	2230	1.36 (1.20E-03)
	AKM2G-43D	AKD2G-SPx-7V03x/AKD-x00307	88	6.97 (61.7)	20.7 (183)	1900	6000	1310	1.95 (1.73E-03)
	AKM2G-43G	AKD2G-SPx-7V06x/AKD-x00607	88	6.97 (61.7)	21.0 (186)	3900	6000	2350	1.95 (1.73E-03)
	AKM2G-43I	AKD2G-SPx-7V12x/AKD-x01207	88	6.98 (61.7)	21.1 (187)	6000	6000	2530	1.95 (1.73E-03)
	AKM2G-44E	AKD2G-SPx-7V03x/AKD-x00307	88	8.48 (75.1)	22.0 (195)	2100	6000	1720	2.53 (2.24E-03)
	AKM2G-44E	AKD2G-SPx-7V06x/AKD-x00607	88	8.48 (75.1)	26.9 (238)	2100	6000	1720	2.53 (2.24E-03)
	AKM2G-44H	AKD2G-SPx-7V06x/AKD-x00607	88	8.51 (75.3)	22.4 (199)	4300	6000	2850	2.53 (2.24E-03)
	AKM2G-44H	AKD2G-SPx-7V12x/AKD-x01207	88	8.49 (75.2)	27.0 (239)	4300	6000	2850	2.53 (2.24E-03)
	AKM2G-44J	AKD2G-SPx-7V12x/AKD-x01207	88	8.47 (75.0)	26.9 (238)	5400	6000	2780	2.53 (2.24E-03)

① For complete AKM2G model nomenclature, refer to page 16.
 ② Max mechanical speeds: 8000 RPM for AKM2G-2,3 and 6000 RPM for AKM2G-4, 5, 6, 7.

System Performance – AKM2G Servo Motors driven by AKD2G and AKD Servo Drives

AKM2G Servo Motor ^①	AKD2G/AKD Servo Drive	Frame Size mm	Continuous Torque Tcs Nm (lb-in)	Peak Torque Tps Nm (lb-in)	Rated Speed Nrt'd RPM	Max System Speed ^② RPM	Power Prtd watts	Inertia (Jm) Kg-cm ² (lb-in-s ²)
AKM2G-51H	AKD2G-SPx-7V06x/AKD-x00607	114	6.82 (60.4)	15.7 (139)	5100	6000	2960	2.52 (2.23E-03)
AKM2G-51I	AKD2G-SPx-7V06x/AKD-x00607	114	6.45 (57.1)	15.3 (135)	5700	6000	3160	2.52 (2.23E-03)
AKM2G-51I	AKD2G-SPx-7V12x/AKD-x01207	114	6.82 (60.3)	15.7 (139)	5700	6000	3160	2.52 (2.23E-03)
AKM2G-52H	AKD2G-SPx-7V06x/AKD-x00607	114	11.4 (101)	28.1 (249)	3200	6000	3440	4.58 (4.05E-03)
AKM2G-52H	AKD2G-SPx-7V12x/AKD-x01207	114	12.0 (106)	29.0 (257)	3200	6000	3440	4.58 (4.05E-03)
AKM2G-52K	AKD2G-SPx-7V12x/AKD-x01207	114	11.9 (106)	28.9 (256)	5300	6000	4340	4.58 (4.05E-03)
AKM2G-53H	AKD2G-SPx-7V06x/AKD-x00607	114	16.2 (144)	41.8 (370)	2200	6000	3320	6.64 (5.88E-03)
AKM2G-53L	AKD2G-SPx-7V12x/AKD-x01207	114	15.4 (136)	34.8 (308)	5100	6000	4610	6.64 (5.88E-03)
AKM2G-53L	AKD2G-SPx-7V24x/AKD-x02407	114	16.1 (142)	41.4 (366)	5100	6000	4610	6.64 (5.88E-03)
AKM2G-54L	AKD2G-SPx-7V12x/AKD-x01207	114	20.1 (178)	52.3 (463)	3400	6000	5080	8.70 (7.70E-03)
AKM2G-54L	AKD2G-SPx-7V24x/AKD-x02407	114	20.1 (178)	54.8 (485)	3400	6000	5080	8.70 (7.70E-03)
AKM2G-54M	AKD2G-SPx-7V12x/AKD-x01207	114	16.4 (145)	39.4 (348)	4800	6000	4920	8.70 (7.70E-03)
AKM2G-54M	AKD2G-SPx-7V24x/AKD-x02407	114	20.0 (177)	54.7 (484)	4800	6000	4920	8.70 (7.70E-03)
AKM2G-62K	AKD2G-SPx-7V12x/AKD-x01207	142	15.3 (135)	37.6 (332)	3700	6000	4590	9.10 (8.05E-03)
AKM2G-62L	AKD2G-SPx-7V12x/AKD-x01207	142	15.2 (134)	33.7 (298)	4800	6000	4950	9.10 (8.05E-03)
AKM2G-62L	AKD2G-SPx-7V24x/AKD-x02407	142	15.2 (135)	37.4 (331)	4800	6000	4950	9.10 (8.05E-03)
AKM2G-63K	AKD2G-SPx-7V12x/AKD-x01207	142	21.5 (190)	54.8 (485)	2700	6000	5030	13.0 (1.15E-02)
AKM2G-63M	AKD2G-SPx-7V24x/AKD-x02407	142	21.4 (189)	54.5 (482)	4500	6000	6050	13.0 (1.15E-02)
AKM2G-64L	AKD2G-SPx-7V12x/AKD-x01207	142	27.0 (239)	63.9 (566)	2600	6000	5950	16.9 (1.50E-02)
AKM2G-64L	AKD2G-SPx-7V24x/AKD-x02407	142	27.1 (240)	70.7 (626)	2600	6000	5950	16.9 (1.50E-02)
AKM2G-64M	AKD2G-SPx-7V24x/AKD-x02407	142	26.9 (238)	70.5 (624)	3700	6000	6840	16.9 (1.50E-02)
AKM2G-64N	AKD2G-SPx-7V24x/AKD-x02407	142	26.8 (237)	64.8 (574)	4200	6000	6670	16.9 (1.50E-02)
AKM2G-64N	AKD-x04807	142	26.8 (237)	70.3 (623)	4200	6000	6670	16.9 (1.50E-02)
AKM2G-65L	AKD2G-SPx-7V12x/AKD-x01207	142	31.7 (280)	73.0 (646)	2300	6000	6460	20.8 (1.84E-02)
AKM2G-65L	AKD2G-SPx-7V24x/AKD-x02407	142	32.7 (289)	86.8 (768)	2300	6000	6460	20.8 (1.84E-02)
AKM2G-65M	AKD2G-SPx-7V24x/AKD-x02407	142	32.6 (289)	86.8 (768)	2900	6000	7380	20.8 (1.84E-02)
AKM2G-65N	AKD2G-SPx-7V24x/AKD-x02407	142	32.7 (289)	75.8 (671)	3800	6000	7790	20.8 (1.84E-02)
AKM2G-65N	AKD-x04807	142	32.7 (289)	87.0 (770)	3800	6000	7790	20.8 (1.84E-02)
AKM2G-71L	AKD2G-SPx-7V12x/AKD-x01207	192	22.7 (201)	49.2 (436)	3200	6000	5880	25.9 (2.29E-02)
AKM2G-71L	AKD2G-SPx-7V24x/AKD-x02407	192	22.9 (202)	49.5 (438)	3200	6000	5880	25.9 (2.29E-02)
AKM2G-71N	AKD2G-SPx-7V24x/AKD-x02407	192	22.7 (201)	49.3 (436)	4900	6000	6120	25.9 (2.29E-02)
AKM2G-72L	AKD2G-SPx-7V12x/AKD-x01207	192	39.5 (349)	87.6 (775)	1900	6000	6810	46.8 (4.14E-02)
AKM2G-72L	AKD2G-SPx-7V24x/AKD-x02407	192	40.5 (358)	89.3 (790)	1900	6000	6810	46.8 (4.14E-02)
AKM2G-72N	AKD2G-SPx-7V24x/AKD-x02407	192	41.1 (364)	90.3 (799)	2900	6000	8620	46.8 (4.14E-02)
AKM2G-72P	AKD2G-SPx-7V24x/AKD-x02407	192	40.6 (359)	82.9 (733)	3400	6000	8600	46.8 (4.14E-02)
AKM2G-72P	AKD-x04807	192	40.6 (359)	89.5 (792)	3400	6000	8600	46.8 (4.14E-02)
AKM2G-73L	AKD2G-SPx-7V12x/AKD-x01207	192	56.5 (500)	127 (1130)	1300	6000	6890	67.7 (5.99E-02)
AKM2G-73N	AKD2G-SPx-7V24x/AKD-x02407	192	57.8 (512)	129 (1150)	1900	6000	9300	67.7 (5.99E-02)
AKM2G-73Q	AKD2G-SPx-7V24x/AKD-x02407	192	49.9 (442)	95.2 (843)	3200	6000	10300	67.7 (5.99E-02)
AKM2G-73Q	AKD-x04807	192	57.0 (504)	128 (1130)	3200	6000	10300	67.7 (5.99E-02)
AKM2G-74P	AKD2G-SPx-7V24x/AKD-x02407	192	72.1 (638)	141 (1250)	2100	6000	11500	88.6 (7.84E-02)
AKM2G-74P	AKD-x04807	192	72.1 (638)	164 (1460)	2100	6000	11500	88.6 (7.84E-02)
AKM2G-74Q	AKD2G-SPx-7V24x/AKD-x02407	192	59.6 (527)	115 (1020)	2700	6000	11700	88.6 (7.84E-02)
AKM2G-74Q	AKD-x04807	192	71.6 (634)	164 (1450)	2700	6000	11700	88.6 (7.84E-02)
AKM2G-74R	AKD-x04807	192	71.2 (630)	163 (1440)	3000	6000	10500	88.6 (7.84E-02)

① For complete AKM2G model nomenclature, refer to page 16.
 ② Max mechanical speeds: 8000 RPM for AKM2G-2,3 and 6000 RPM for AKM2G-4, 5, 6, 7.

AKM2G Servo Motor Nomenclature

AKM2G Brushless Servo Motor

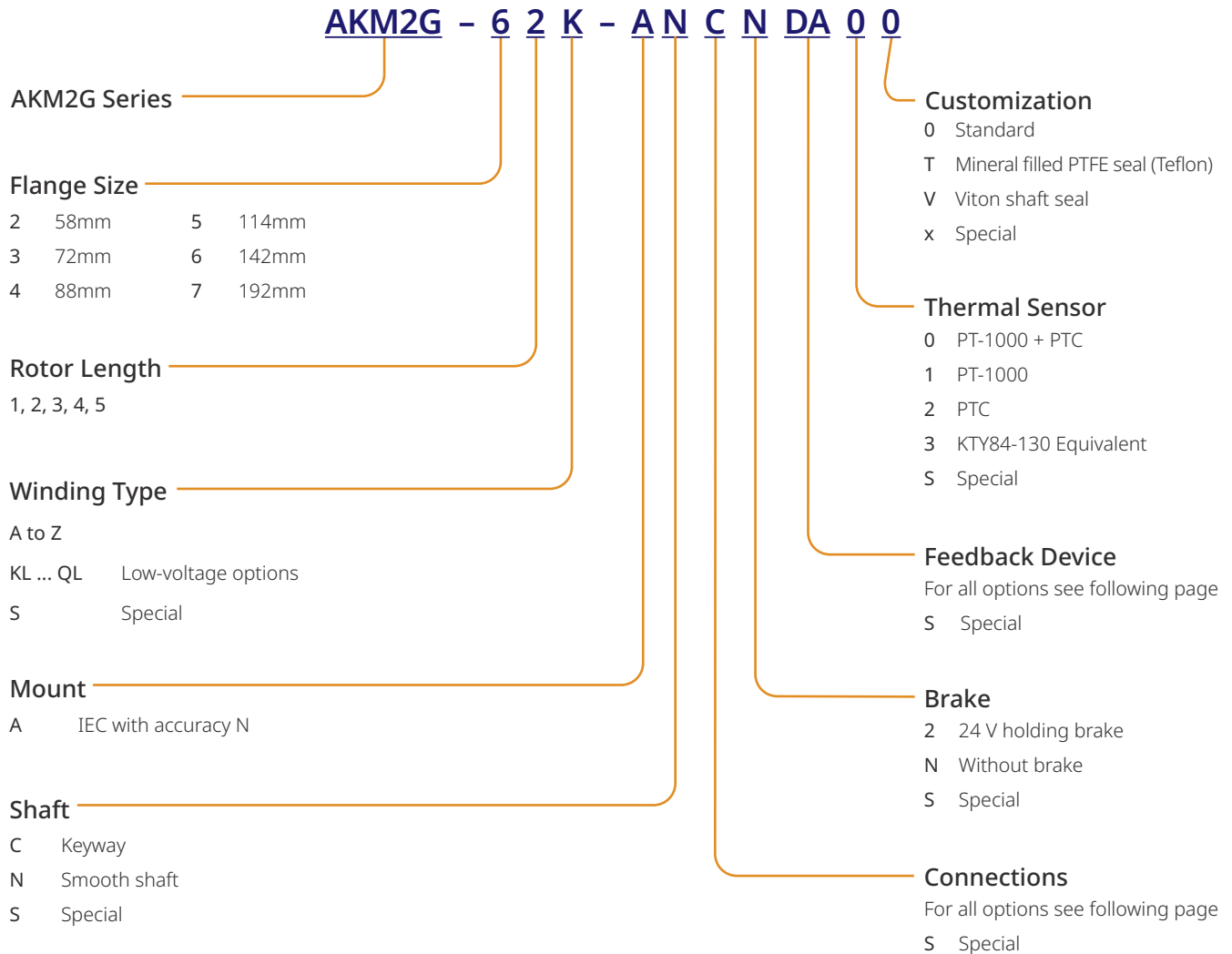

Feedback Unit Options

Functional Safety Capable

					Feedback Resolution					
Code ³	Description	AKM2Gx ⁴	Connector	Single-turn or Multi-turn	Feedback Type/Size	Device Resolution (Sin/Cos per Rev., Bits or Lines/Rev.)	AKD Internal Resolution	AKD2G Internal Resolution	# of Absolute revs.	Accuracy ^{1,2} (arc-sec)
2-	Commutating Encoder	2 non-LV	Y	Single-turn	15	2048 Lines	8,192	8,192	None	±218.2"
		3-4	Ad, C							
		5-7 ≤ 20A								
AA	BiSS B Optical Sine Encoder	2 non-LV	Y	Single-turn	AD34	2048 Sin/Cos	27-Bits	32-Bits	1	±36"
		3, 4	Ad, C							
		5-7 ≤ 20A								
AB	BiSS B Optical Sine Encoder	2 non-LV	Y	Multi-turn	AD34	2048 Sin/Cos	27-Bits	32-Bits	4096	±36"
		3, 4	Ad, C							
		5-7 ≤ 20A								
CA	SFD3 Smart Feedback Device Gen. 3	2-4	AH, D	Single-turn	15	24-Bits	24-Bits	24-Bits	1	±585"
		5-7 ≤ 20A	AH, D							
		7 > 20A			E					
CB	SFD-M Smart Feedback Device Multi-turn	2-7 ≤ 20A	AH, D	Multi-turn	15	24-Bits	24-Bits	24-Bits	65,536	±60"
		7 > 20A	E							
GU	HIPERFACE DSL Capacitive	2-7 ≤ 20A	D	Multi-turn	EEM37-2*	17-Bits	17-Bits	17-Bits	1	±240"
		7 > 20A	J							
DA	EnDat 2.2/01 Optical	2 non-LV	Y	Single-turn	ECN1113	512 Sin/Cos	25-Bits	32-Bits	1	±60"
		3, 4	Ad, C		ECN1313	2048 Sin/Cos	27-Bits			±20"
		5-7 ≤ 20A								
DB	EnDat 2.2/01 Optical	2 non-LV	Y	Multi-turn	EQN1125	512 Sin/Cos	25-Bits	32-Bits	4096	±60"
		3, 4	Ad, C		EQN1325	2048 Sin/Cos	27-Bits			±20"
		5-7 ≤ 20A								
LD	EnDat 2.2/22 Inductive	2-4	D	Multi-turn	EQI 1131**	19-Bits	19-Bits	19-Bits	4096	±120"
		5-7 ≤ 20A	H		EQI 1331**					±65"
		7 > 20A								
R-	Resolver Inductive	2 non-LV	Y	Single-turn	15	1 pole pair (16-Bits)	16-Bits	16-Bits	1	±600"
		3-4	Ad, C							
		5-7 ≤ 20A								
		7 > 20A	H		21					±540"

AH = M23 Hybrid power/SFD3/SFD-M connector pinned for use with legacy AKM performance cables – not compatible with AKM2G cables.

Ad = M23 Dual connectors with power connector pinned for use with legacy AKM performance cables – not compatible with AKM2G cables.

- AKD drives have a resolver measurement accuracy of ±45", for a drive w/ motor accuracy of ±585" and RMS Noise of ±9.9" Accuracy & RMS Noise data when used with other drives may be different.
- Accuracy refers to overall system accuracy once installed in the motor. Noise refers to the RMS position noise when at stand-still.
- All feedback options, except R- and 2-, have Motor ID support with embedded electronic motor nameplate data included for easy plug-and-play commissioning with Kollmorgen servo drives.
- AKM2G-LV Size 2 models are only available in single-connector configurations.

With AKD drives, all received positions are interpolated to a 32-bit resolution per revolution. When using a drive other than AKD consult the drive manufacturer for this information.

*SICK HIPERFACE DSL model EEM37-2. Please visit <https://www.sick.com> to download the latest safety data sheet.

**HEIDENHAIN models EQI1131 & EQI1331. Please visit <https://www.heidenhain.com> to download the latest safety data sheets.

AKM2G Servo Motor Nomenclature

Connector Options

Model Designation	Connection	Compatible AKM2Gx	Position of connection
A* (Hybrid)	1 SpeedTec M23 (AKM cable pinned)	AKM2G2 - AKM2G7 ≤ 20 Amps	Angular, rotatable, motor mounted
A (Dual)	2 SpeedTec M23 (AKM cable pinned)	AKM2G3 - AKM2G7 ≤ 20 Amps	Angular, rotatable, motor mounted
C	2 SpeedTec M23	AKM2G3 - AKM2G7 ≤ 20 Amps	Angular, rotatable, motor mounted
D*	1 htec M23	AKM2G2 - AKM2G7 ≤ 20 Amps	Angular, rotatable, motor mounted
E*	1 M40 (AKM cable pinned)	AKM2G7 > 20 Amps	Angular, rotatable, motor mounted
H	1 M40 Power, 1 M23 Feedback	AKM2G7 > 20 Amps	Angular, rotatable, motor mounted
J*	1 htec Connector M40	AKM2G7 > 20 Amps	Angular, rotatable, motor mounted
Y	1 ytec Connector	AKM2G2 (non LV)	Rotatable, motor mounted

* Hybrid connectors valid for SFD3, SFD-M, HDSL, and EnDat 2.2 Feedback only.

Connector Description

Connector	Usage	Contacts - Pins Power/Signal	Max. Current [A] Power/Signal	Max. Cross Section [mm ²] Power/Signal	Protection Class
M23 SpeedTec right angle connectors (Size 1)	Power & Brake	4 / 5	20 / 10	4 / 1.5	IP65
	Comcoder	- / 15	- / 10	4 / 1.5	IP65
	Resolver	- / 12	- / 10	- / 0.5	IP65
	HDSL	5 / 2 / 2	20 / 10	4 / 1.5	IP65
	SFD3/SFD-M	4 / 5	20 / 10	4 / 1.5	IP65
	EnDat 2.2	5 / 4 / 6	20 / 10	4 / 1.5	IP65
	EnDat 2.1 / BiSS B	- / 12	- / 10	4 / 1.5	IP65
M40 (Size 1.5)	Power & Brake	4 / 5	48 / 30	16 / 4	IP65
	SFD3	4 / 5	48 / 30	16 / 4	IP65
	HDSL	5 / 4 / 2	48 / 30	16 / 4	IP65
ytec	Power & Brake	4 / 5	7 / 3.6	1.5 / 0.75	IP65
	Resolver	- / 12	- / 5	- / 0.75	IP65
	EnDat 2.1 / BiSS B	- / 12	- / 5	- / 0.75	IP65

Feedback and Connector Availability

AKM2G-2

Connector Code	A	D	Y
2-			•
Ax			•
Cx	•	•	
GU		•	
Dx			•
LD		•	
R-			•

AKM2G- 3-6

Connector Code	A	C	D
2-	•	•	
Ax	•	•	
Cx	•		•
GU			•
Dx	•	•	
LD			•
R-	•	•	

AKM2G-7 (L, N Windings)

Connector Code	A	C	D
2-	•	•	
Ax	•	•	
Cx	•		•
GU			•
Dx	•	•	
LD			•
R-	•	•	

AKM2G-7 (P, Q, R Windings)

Connector Code	A	E	H	J
2-	•		•	
Ax	•		•	
Cx		•	•	
GU				•
Dx	•		•	
LD			•	
R-	•		•	

- = Hybrid (power + feedback) single connector
- = Dual power and feedback connectors

Notes



0.125 inch divisions

AKM2G-2x Series Motor Specifications

AKM2G-2x Performance Data – Up to 480 Vac voltage

Parameters	Tol	Symbol	Units	AKM2G-21			AKM2G-22			AKM2G-23			AKM2G-24		
				D	E	G	C	D	E	D	E	F	D	E	F
Max Rated Equivalent Line Voltage	Max	V _{bus}	Vac	480	240	120	480	480	240	480	480	240	480	480	480
Continuous Torque for ΔT winding = 100 °C ①②③⑤	Nom	T _{CS}	Nm	0.636	0.642	0.649	1.11	1.11	1.11	1.48	1.48	1.50	1.80	1.81	1.83
			lb-in	5.62	5.68	5.75	9.80	9.81	9.86	13.1	13.1	13.3	16.0	16.0	16.2
Continuous Current for ΔT winding = 100 °C ①②③	Nom	I _{CS}	A _{RMS}	2.17	2.73	4.18	1.65	2.37	2.93	2.11	2.92	4.07	2.11	2.92	4.11
Continuous Torque for ΔT winding = 60 °C ②③⑤	Nom	T _{CS}	Nm	0.494	0.498	0.503	0.859	0.861	0.863	1.150	1.151	1.168	1.40	1.41	1.43
			lb-in	4.37	4.41	4.45	7.60	7.62	7.64	10.2	10.2	10.3	12.4	12.5	12.6
Max Mechanical Speed ④	Nom	N _{max}	rpm	8000	8000	8000	8000	8000	8000	8000	8000	8000	8000	8000	8000
Peak Torque ①②③	Nom	T _p	Nm	1.78	1.79	1.79	3.33	3.33	3.34	4.69	4.69	4.74	5.93	5.95	6.00
			lb-in	15.7	15.8	15.9	29.4	29.5	29.5	41.5	41.5	41.9	52.5	52.6	53.1
Peak Current	Nom	I _p	A _{RMS}	8.66	10.9	16.7	6.62	9.49	11.7	8.44	11.7	16.3	8.45	11.7	16.4
Rated Torque (speed) ①②③		T _{rtd}	Nm	0.583	0.568	0.545	1.09	1.07	1.06	1.45	1.42	1.39	1.76	1.74	1.71
			lb-in	5.16	5.02	4.82	9.67	9.51	9.38	12.8	12.5	12.3	15.6	15.4	15.2
Rated Speed		N _{rtd}	rpm	4800	6200	8000	1800	2900	3800	1800	2800	4100	1500	2300	3400
Rated Power (speed) ①②③		P _{rtd}	kW	0.293	0.369	0.456	0.206	0.326	0.422	0.273	0.416	0.599	0.277	0.419	0.610
			Hp	0.393	0.494	0.612	0.276	0.438	0.565	0.366	0.557	0.803	0.371	0.562	0.818
Rated Torque (speed) ①②③		T _{rtd}	Nm	0.534	0.534	-	1.04	0.991	0.955	1.37	1.29	1.22	1.67	1.60	1.47
			lb-in	4.73	4.73	-	9.21	8.77	8.45	12.1	11.4	10.8	14.8	14.1	13.0
Rated Speed		N _{rtd}	rpm	8000	8000	-	4400	6600	8000	4300	6200	8000	3600	5100	7300
			kW	0.448	0.448	-	0.480	0.685	0.800	0.615	0.839	1.02	0.629	0.853	1.13
Rated Power (speed) ①②③		P _{rtd}	Hp	0.600	0.600	-	0.643	0.919	1.07	0.825	1.12	1.37	0.844	1.14	1.51
			kW	0.439	-	-	0.781	0.786	-	0.977	0.993	-	0.999	1.16	1.14
Rated Torque (speed) ①②③		T _{rtd}	Nm	0.525	-	-	0.956	0.938	-	1.23	1.19	-	1.51	1.39	1.36
			lb-in	4.64	-	-	8.46	8.30	-	10.9	10.5	-	13.4	12.3	12.0
Rated Speed		N _{rtd}	rpm	8000	-	-	7800	8000	-	7600	8000	-	6300	8000	8000
			kW	0.439	-	-	0.781	0.786	-	0.977	0.993	-	0.999	1.16	1.14
Rated Power (speed) ①②③		P _{rtd}	Hp	0.589	-	-	1.048	1.05	-	1.31	1.33	-	1.34	1.56	1.52
			kW	0.435	-	-	0.791	0.777	-	1.00	0.978	-	1.13	1.14	1.11
Rated Torque (speed) ①②③		T _{rtd}	Nm	0.520	-	-	0.944	0.928	-	1.20	1.17	-	1.42	1.36	1.32
			lb-in	4.60	-	-	8.36	8.21	-	10.6	10.3	-	12.59	12.06	11.68
Rated Speed		N _{rtd}	rpm	8000	-	-	8000	8000	-	8000	8000	-	7600	8000	8000
			kW	0.435	-	-	0.791	0.777	-	1.00	0.978	-	1.13	1.14	1.11
Rated Power (speed) ①②③		P _{rtd}	Hp	0.584	-	-	1.06	1.04	-	1.35	1.31	-	1.52	1.53	1.48

Notes:

- ① Motor winding temperature rise, ΔT = 100 °C, at 40 °C ambient.
- ② All data referenced to sinusoidal commutation.
- ③ Motor with resolver feedback and standard heat sink.
- ④ May be limited at some values of V_{bus}.
- ⑤ See de-rate curves for the de-rate of different motor options

AKM2G-2x Motor Parameters

Parameters	Tol	Symbol	Units	AKM2G-21			AKM2G-22			AKM2G-23			AKM2G-24		
				D	E	G	C	D	E	D	E	F	D	E	F
Torque Constant ①	±10%	K _t	Nm/A _{rms}	0.296	0.238	0.157	0.676	0.472	0.384	0.710	0.512	0.373	0.863	0.627	0.451
			lb-in/A _{rms}	2.62	2.10	1.39	5.99	4.18	3.40	6.28	4.53	3.30	7.64	5.55	3.99
Back EMF Constant ②	±10%	K _e	V _{rms} /k _r rpm	19.5	15.6	10.3	44.2	30.9	25.1	46.1	33.3	24.2	55.7	40.5	29.1
Motor Constant ⑥	Nom	K _m	N-m/√W	0.0895	0.0902	0.0911	0.144	0.144	0.145	0.187	0.187	0.190	0.225	0.226	0.229
			lb-in/√W	0.792	0.798	0.807	1.28	1.28	1.28	1.66	1.66	1.68	1.99	2.00	2.03
Resistance (line-line) ②	±10%	R _m	Ohm	7.30	4.63	1.97	14.7	7.11	4.69	9.60	4.99	2.57	9.84	5.15	2.58
Inductance Q-Axis (line-line)		L _{qll}	mH	16.3	10.5	4.55	37.9	18.5	12.2	26.5	13.8	7.32	28.4	15.0	7.75
Inductance D-Axis (line-line)		L _{dll}	mH	Contact Factory	Contact Factory	Contact Factory	Contact Factory	Contact Factory	Contact Factory	Contact Factory	Contact Factory	Contact Factory	Contact Factory	Contact Factory	Contact Factory
Inductance Saturation Current		Lisat	Arms	15	19	29	13	19	24	19	27	37	21	29	41
Maximum Demagnetization Current		Midpeak	Arms	Contact Factory	Contact Factory	Contact Factory	Contact Factory	Contact Factory	Contact Factory	Contact Factory	Contact Factory	Contact Factory	Contact Factory	Contact Factory	Contact Factory
Inertia (includes Resolver feedback) ③	±10%	J _m	kg-cm ²	0.093			0.155			0.217			0.279		
			lb-in-s ²	8.23E-05			1.37E-04			1.92E-04			2.47E-04		
Optional Brake Inertia (additional)	±10%	J _m	kg-cm ²	0.040			0.040			0.040			0.040		
			lb-in-s ²	3.54E-05			3.54E-05			3.54E-05			3.54E-05		
Weight without brake ④		W	kg	1.1			1.4			1.7			2.0		
			lb	2.4			3.1			3.7			4.4		
Static Friction ①⑤		T _f	Nm	0.006			0.011			0.015			0.019		
			lb-in	0.05			0.10			0.13			0.17		
Viscous Damping ①		K _{dv}	Nm/k _r rpm	0.0015			0.0030			0.0045			0.0060		
			lb-in/k _r rpm	0.013			0.027			0.040			0.053		
Thermal Time Constant		TCT	minutes	9.6			10.8			11.9			13.0		
Coil Thermal Time Constant		MCT _{f0}		Contact Factory			Contact Factory			Contact Factory			Contact Factory		
Thermal Resistance ①		R _{thw-a}	K/W	1.33			1.14			1.07			1.04		
Pole Pairs		PP		3			3			3			3		
Heat Sink Size				10"x10"x1/4" Aluminum Plate			10"x10"x1/4" Aluminum Plate			10"x10"x1/4" Aluminum Plate			10"x10"x1/4" Aluminum Plate		

Notes:

- ① Motor winding temperature rise, ΔT = 100 °C, at 40 °C ambient.
- ② Measured at 25 °C.
- ③ Add parking brake if applicable for total inertia.
- ④ Brake motor adds 0.45 kg [1.0 lbs]
- ⑤ Shaft seal increases Static Friction by 0.020 Nm [0.21 lb-in]
- ⑥ This value is calculated from the Torque Constant and Resistance. Refer to those values and notes ① & ② for additional details.

AKM2G-2x Series Motor Specifications

AKM2G-2x Derate Curves

Refer to the [Servo Motor Performance Curve Overview](#) section for additional details about Derate.

Example:

For an AKM2G-21 motor with an SFD feedback with shaft seal and no brake operating at 3000 RPM there is a 10.1% De-rate. Multiply the motor torque value (T_{CS}) by .899 for the rated torque at 3000 RPM. For ease of interpretation of the graph using a De-rate that is a rounded approximation is acceptable. For exact values refer to Kollmorgen's Motioneering Application Sizing programs, or the Kollmorgen website Performance Curve Generator.

Note: De-rates are referenced to the Continuous Torque ΔT wdg. = 100 °C.

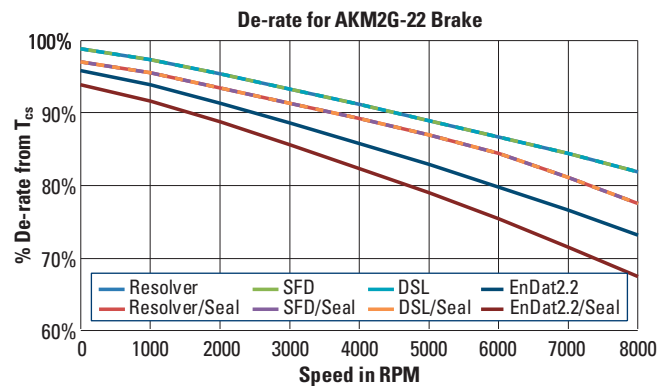
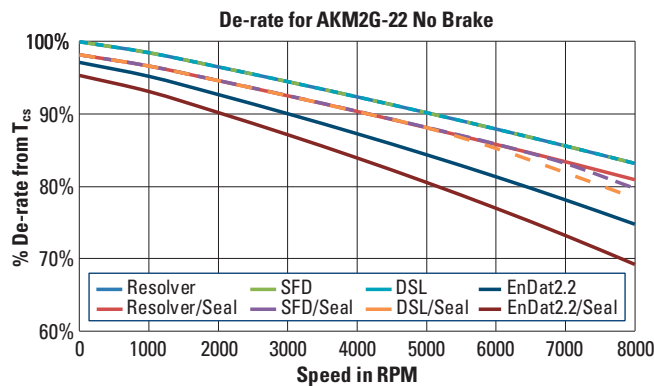
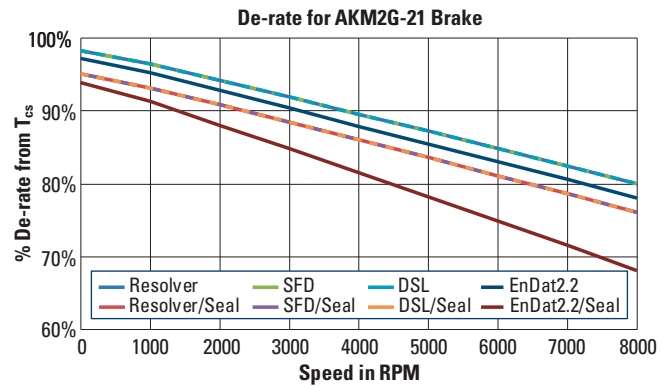
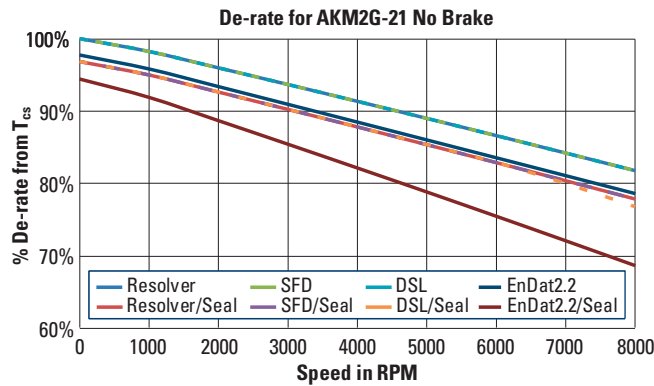

Continued on following page

! IMPORTANT

Derate information for general estimation only. Use the on-line Performance Curve Generator located at <https://www.kollmorgen.com/en-us/service-and-support/technical/performance-curve-generator> for the most accurate information for your motor, or refer to Kollmorgen's Motioneering Online Tool located at <https://www.kollmorgen.com/en-us/service-and-support/technical/motioneering-online>

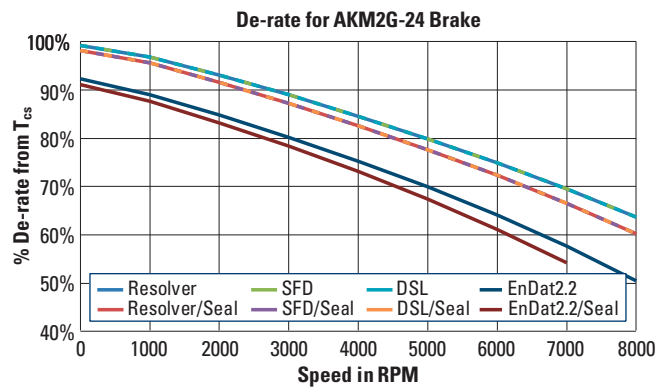
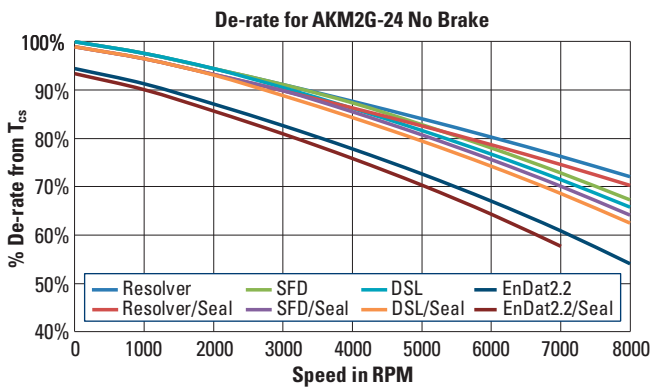
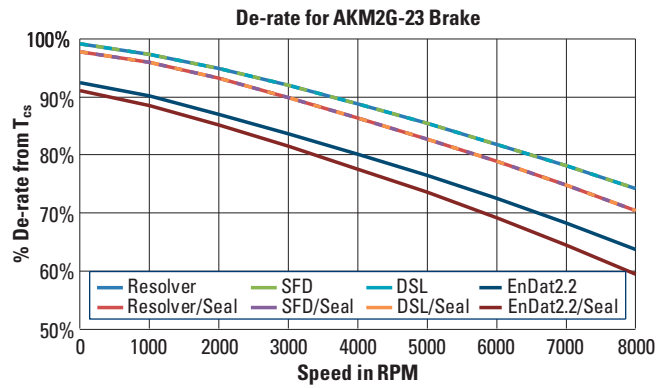
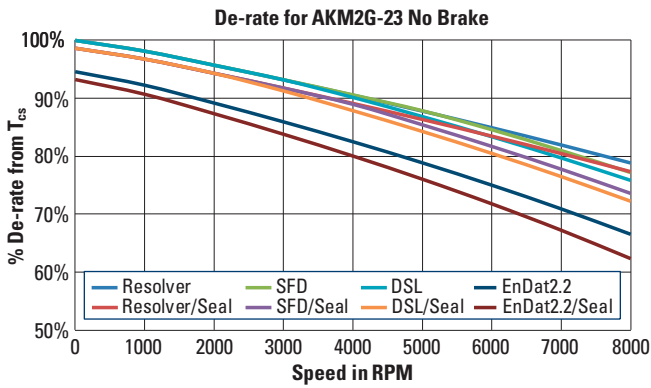

AKM2G-2x Series Motor Specifications

AKM2G-2x Dimensional Drawings and Data

AKM2G-2x Single A-, D- Connector Frame

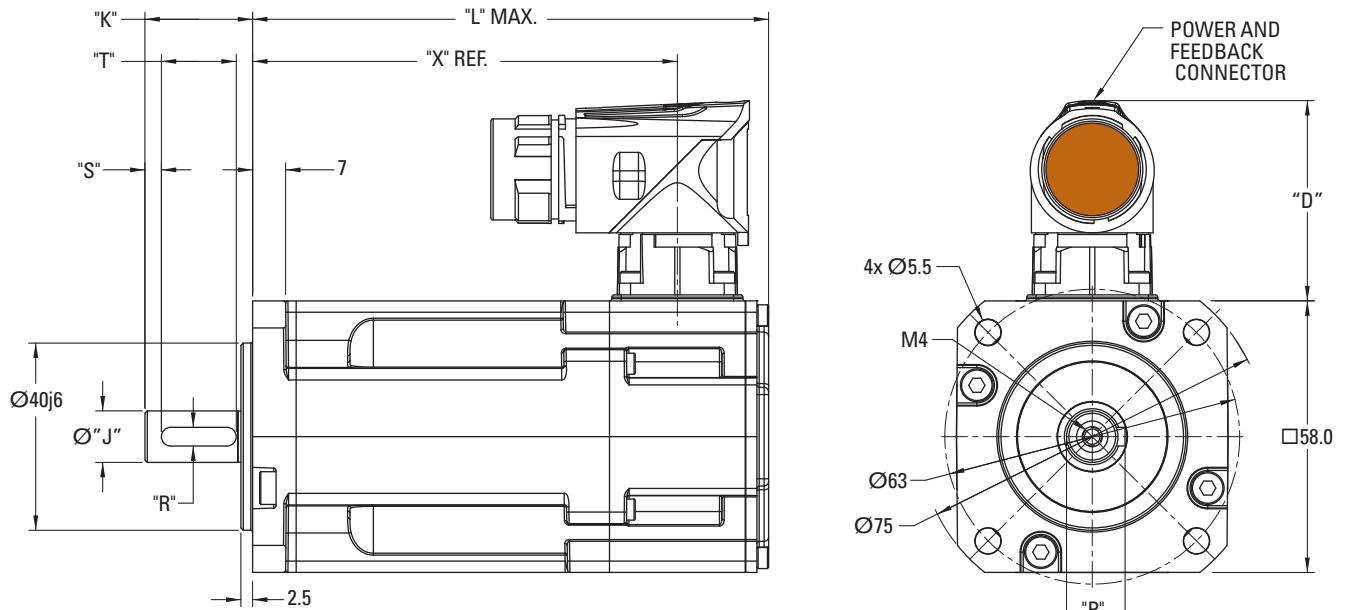

AKM2G-2x ytec- Dual Connector Option

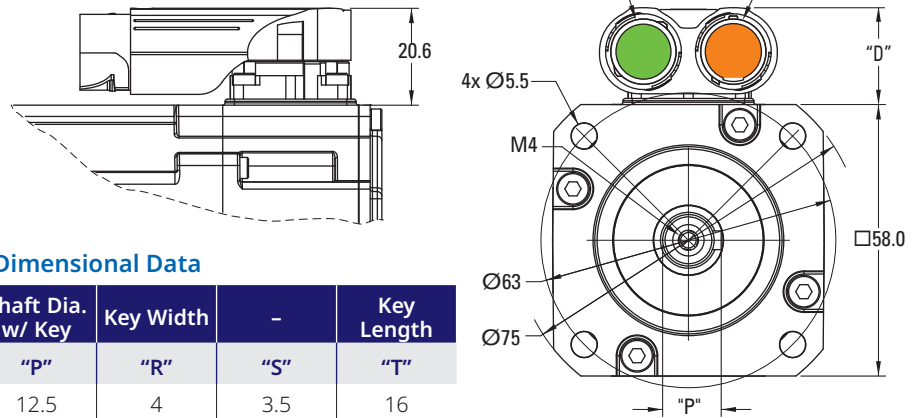

AKM2G-2x Mounting Flange-Shaft Dimensional Data

Mounting Flange-Shaft	Shaft Diameter	Shaft Length	Shaft Dia. w/ Key	Key Width	-	Key Length
	"J"	"K"	"P"	"R"	"S"	"T"
AC	11k6	23	12.5	4	3.5	16
AN	11k6	23	-	-	-	-

All dimensions in mm

AKM2G-2x "X" and "L" Dimensions

Connector	No Brake (N)		
	"L" MAX		"X" REF
	A-, D-, Y-	D-, Y-	A-, D-, Y-
Feedback Option	Cx, 2-, Ax, R-	Dx, GU, LD	Cx, 2-, Ax, Dx, GU, LD, R-
AKM2G-21	111.15	118.15	90.75
AKM2G-22	130.40	137.40	110.00
AKM2G-23	149.65	156.65	149.65
AKM2G-24	168.90	175.90	148.50
+ Brake ("2" option)	All AKM2G-2x: Add +39.00 mm to both "L" and "X" dimensions		

All dimensions in mm

AKM2G-2x Connector Height

Connector Feedback	"D"
SFD3 (CA), SFD-M (CB)	42.8
DSL (GU) & EnDat 2.2/22 (LD)	44.1
2-, Ax, Dx, R-	20.6

Note: Product designed in metric.

Related Topics:

[Feedback Options and Specifications](#)
[Connector Options and Pinouts](#)

Notes

AKM2G - 2 2 A - A N C N DA O O
Motor Series Frame Size Rotor Length Winding Type Shaft Mount Connections Brake Feedback Thermal Sensor Customization

0.125 inch divisions

AKM2G-3x Series Motor Specifications

AKM2G-3x Performance Data – Up to 480 V_{ac} voltage

Parameters	Tol	Symbol	Units	AKM2G-31			AKM2G-32			AKM2G-33		
				C	D	E	D	E	G	E	G	H
Max Rated Equivalent Line Voltage	Max	V _{bus}	V _{ac}	480	480	480	480	480	400	480	480	400
Continuous Torque for ΔT winding = 100 °C ①②③⑤	Nom	T _{CS}	Nm	1.68	1.68	1.70	2.81	2.80	2.90	3.86	3.81	3.85
			lb-in	14.9	14.9	15.1	24.8	24.8	25.7	34.1	33.7	34.1
Continuous Current for ΔT winding = 100 °C ①②③	Nom	I _{CS}	A _{rms}	1.48	2.06	2.90	2.17	2.75	4.24	2.99	4.24	5.80
Continuous Torque for ΔT winding = 60 °C ②③⑤	Nom	T _{CS}	Nm	1.30	1.31	1.33	2.18	2.18	2.26	3.00	2.97	3.01
			lb-in	11.5	11.6	11.7	19.3	19.3	20.0	26.5	26.3	26.7
Max Mechanical Speed ④	Nom	N _{max}	rpm	8000	8000	8000	8000	8000	8000	8000	8000	8000
Peak Torque ①②③	Nom	T _p	Nm	5.99	6.00	6.06	10.4	10.3	10.6	14.6	14.4	14.6
			lb-in	53.0	53.1	53.6	91.7	91.6	94.2	129	128	129
Peak Current	Nom	I _p	A _{rms}	5.90	8.23	11.6	8.66	11.0	17.0	12.0	16.9	23.2
120 V _{ac} Rated Torque (speed) ①②③		T _{rtd}	Nm	1.67	1.67	1.68	-	2.78	2.82	-	3.71	3.68
			lb-in	14.8	14.8	14.8	-	24.6	25.0	-	32.8	32.5
120 V _{ac} Rated Speed		N _{rtd}	rpm	1000	1500	2300	-	1300	2300	-	1600	2250
120 V _{ac} Rated Power (speed) ①②③		P _{rtd}	kW	0.175	0.263	0.404	-	0.378	0.680	-	0.622	0.866
			Hp	0.235	0.352	0.542	-	0.507	0.912	-	0.833	1.16
240 V _{ac} Rated Torque (speed) ①②③		T _{rtd}	Nm	1.64	1.62	1.59	2.72	2.67	2.60	3.64	3.44	3.20
			lb-in	14.5	14.3	14.1	24.1	23.6	23.0	32.2	30.4	28.3
240 V _{ac} Rated Speed		N _{rtd}	rpm	2400	3500	5000	2200	2900	4700	2300	3350	4600
240 V _{ac} Rated Power (speed) ①②③		P _{rtd}	kW	0.412	0.594	0.832	0.628	0.811	1.28	0.878	1.21	1.54
			Hp	0.553	0.796	1.12	0.842	1.09	1.72	1.18	1.62	2.07
400 V _{ac} Rated Torque (speed) ①②③		T _{rtd}	Nm	1.58	1.52	1.43	2.58	2.46	2.17	3.33	2.83	1.88
			lb-in	14.0	13.5	12.7	22.9	21.8	19.2	29.5	25.1	16.6
400 V _{ac} Rated Speed		N _{rtd}	rpm	4300	6100	8000	3900	5000	7600	4000	5800	8000
400 V _{ac} Rated Power (speed) ①②③		P _{rtd}	kW	0.713	0.972	1.20	1.06	1.29	1.72	1.39	1.72	1.57
			Hp	0.956	1.30	1.61	1.42	1.73	2.31	1.87	2.31	2.11
480 V _{ac} Rated Torque (speed) ①②③		T _{rtd}	Nm	1.55	1.46	1.39	2.50	2.33	-	3.14	2.42	-
			lb-in	13.7	12.9	12.3	22.1	20.6	-	27.8	21.4	-
480 V _{ac} Rated Speed		N _{rtd}	rpm	5200	7300	8000	4700	6100	-	4800	7000	-
480 V _{ac} Rated Power (speed) ①②③		P _{rtd}	kW	0.844	1.12	1.16	1.23	1.49	-	1.58	1.77	-
			Hp	1.13	1.50	1.56	1.65	1.99	-	2.11	2.38	-

Notes:

- ① Motor winding temperature rise, ΔT = 100 °C, at 40 °C ambient.
- ② All data referenced to sinusoidal commutation.
- ③ Motor with resolver feedback and standard heat sink.
- ④ May be limited at some values of V_{bus}.
- ⑤ See de-rate curves for the de-rate of different motor options

AKM2G-3x Motor Parameters

Parameters	Tol	Symbol	Units	AKM2G-31			AKM2G-32			AKM2G-33		
				C	D	E	D	E	G	E	G	H
Torque Constant ①	±10%	K _t	Nm/A _{rms}	1.16	0.836	0.601	1.33	1.05	0.701	1.33	0.924	0.683
			lb-in/A _{rms}	10.3	7.399	5.318	11.8	9.26	6.20	11.7	8.18	6.04
Back EMF Constant ②	±10%	K _e	V _{rms} /k _r rpm	75.6	54.4	39.1	86.1	67.7	45.4	85.6	59.7	44.1
Motor Constant ⑥	Nom	K _m	N-m/√W	0.205	0.206	0.209	0.326	0.325	0.337	0.429	0.426	0.431
			lb-in/√W	1.82	1.83	1.85	2.88	2.88	2.99	3.80	3.77	3.82
Resistance (line-line) ②	±10%	R _m	Ohm	21.4	10.9	5.49	11.14	6.90	2.87	6.35	3.14	1.67
Inductance Q-Axis (line-line)		L _{qll}	mH	46.9	24.2	12.5	24.7	15.3	6.8	15.1	7.3	4.0
Inductance D-Axis (line-line)		L _{dll}	mH	Contact Factory	Contact Factory	Contact Factory	Contact Factory	Contact Factory	Contact Factory	Contact Factory	Contact Factory	Contact Factory
Inductance Saturation Current		L _{isat}	Arms	20	28	39	36	46	68	54.4	78.0	105.5
Maximum Demagnetization Current		Midpeak	Arms	Contact Factory	Contact Factory	Contact Factory	Contact Factory	Contact Factory	Contact Factory	Contact Factory	Contact Factory	Contact Factory
Inertia (includes Resolver feedback) ③	±10%	J _m	kg-cm ²	0.426			0.813			1.200		
			lb-in-s ²	3.77E-04			7.20E-04			1.06E-03		
Optional Brake Inertia (additional)	±10%	J _m	kg-cm ²	0.120			0.120			0.120		
			lb-in-s ²	1.06E-04			1.06E-04			1.06E-04		
Weight without brake ④		W	kg	1.8			2.5			3.3		
			lb	4.0			5.6			7.2		
Static Friction ①⑤		T _f	Nm	0.013			0.023			0.031		
			lb-in	0.12			0.20			0.27		
Viscous Damping ①		K _{dv}	Nm/k _r rpm	0.0039			0.0078			0.0117		
			lb-in/k _r rpm	0.035			0.069			0.104		
Thermal Time Constant		TCT	minutes	17			21			25		
Coil Thermal Time Constant		MCT _{f0}		Contact Factory			Contact Factory			Contact Factory		
Thermal Resistance ①		R _{thw-a}	K/W	0.980			0.868			0.795		
Pole Pairs		PP		4			4			4		
Heat Sink Size				10"x10"x1/4" Aluminum Plate			10"x10"x1/4" Aluminum Plate			10"x10"x1/4" Aluminum Plate		

Notes:

- ① Motor winding temperature rise, ΔT = 100 °C, at 40 °C ambient.
- ② Measured at 25 °C.
- ③ Add parking brake if applicable for total inertia.
- ④ Brake motor adds 0.72 kg [1.6 lbs]
- ⑤ Shaft seal increases Static Friction by 0.017 Nm [0.15 lb-in]
- ⑥ This value is calculated from the Torque Constant and Resistance. Refer to those values and notes ① & ② for additional details.

AKM2G-3x Series Motor Specifications

AKM2G-3x De-rate Curves

Refer to the [Servo Motor Performance Curve Overview](#) section for additional details about Derate.

Example:

For an AKM2G-31 motor with an SFD feedback with shaft seal and no brake operating at 3000 RPM there is a 7.3% De-rate. Multiply the motor torque value (T_{CS}) by .927 for the rated torque at 3000 RPM. For ease of interpretation of the graph using a De-rate that is a rounded approximation is acceptable. For exact values refer to Kollmorgen's Motioneering Application Sizing programs, or the Kollmorgen website Performance Curve Generator.

Note: De-rates are referenced to the Continuous Torque ΔT wdg. = 100 °C.

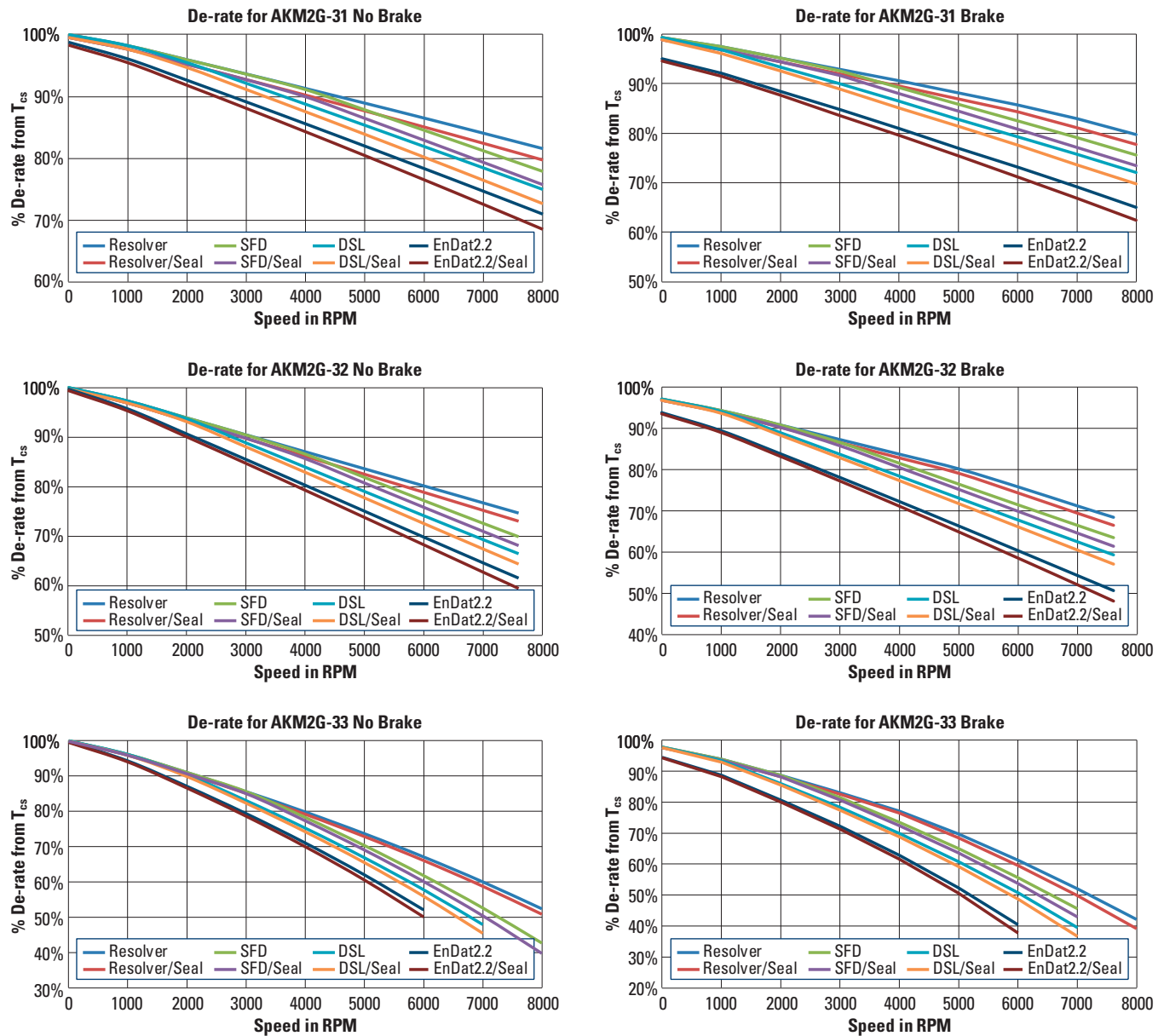

IMPORTANT

Derate information for general estimation only. Use the on-line Performance Curve Generator located at <https://www.kollmorgen.com/en-us/service-and-support/technical/performance-curve-generator> for the most accurate information for your motor, or refer to Kollmorgen's Motioneering Online Tool located at <https://www.kollmorgen.com/en-us/service-and-support/technical/motioneering-online>

AKM2G-3x Dimensional Drawings

AKM2G-3x A-, D- Single Connector Frame

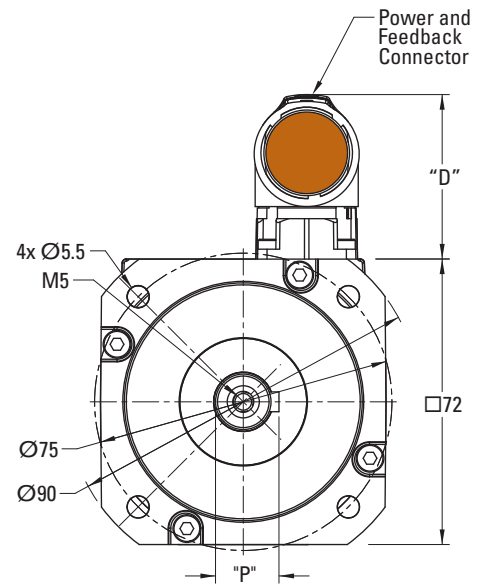
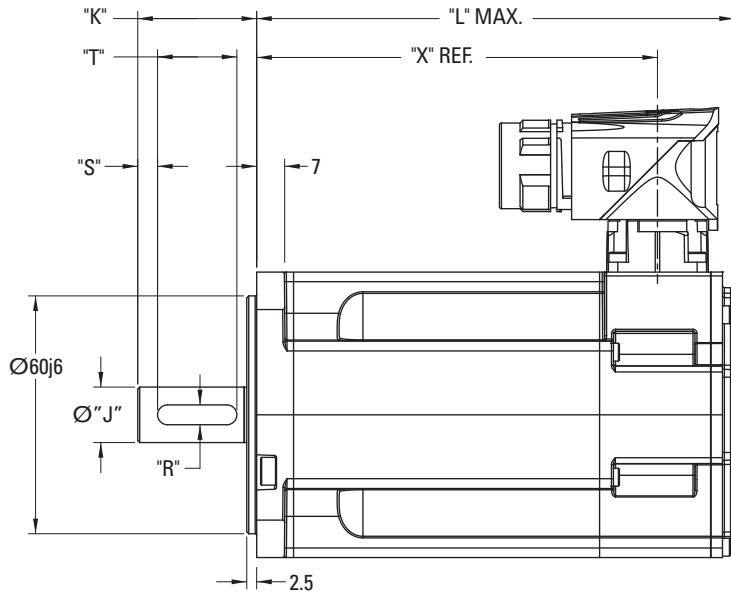

AKM2G-3x Mounting Flange-Shaft Dimensional Data

Mounting Flange-Shaft	Shaft Diameter	Shaft Length	Shaft Dia. w/ Key	Key Width	-	Key Length
	"J"	"K"	"P"	"R"	"S"	"T"
AC	14k6	30	16	5	5	20
AN	14k6	30	-	-	-	-
GC	11k6	23	12.5	4	3.5	16
GN	11k6	23	-	-	-	-

All dimensions in mm

AKM2G-3x Connector Height

Connector Feedback	"D"
SFD3 (CA), SFD-M	42.8
DSL (GU) & EnDat 2.2/22 (LD)	44.1

Note: Product designed in metric.

AKM2G-3x "X" and "L" Dimensions

Connector	No Brake (N)		
	"L" MAX		"X" REF
	A-, C-, D-	A-, C-, D-	A-, D-, Y-
Feedback Option	Cx, 2-, Ax, R-	Dx, GU, LD	Cx, 2-, Ax, Dx, GU, LD, R-
AKM2G-31	121.4	129.4	101.10
AKM2G-32	152.55	160.55	132.25
AKM2G-33	183.7	191.7	163.4
+ Brake ("2" option)	All AKM2G-3x: Add +41.20 mm to both "L" and "X" dimensions		

All dimensions in mm

AKM2G-3x A-, C- Dual Connector Option

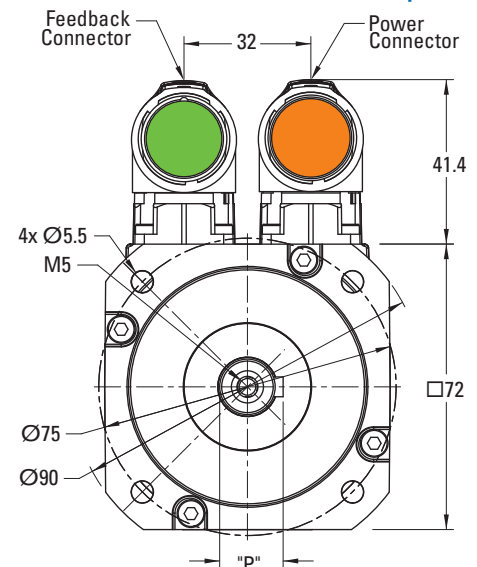

Related Topics:

[Feedback Options and Specifications](#)
[Connector Options and Pinouts](#)

AKM2G-4x Series Motor Specifications

AKM2G-4x Performance Data – Up to 480 Vac voltage

Parameters	Tol	Symbol	Units	AKM2G-41			AKM2G-42			AKM2G-43			AKM2G-44		
				D	E	G	D	E	H	D	G	I	E	H	J
Max Rated Equivalent Line Voltage	Max	Vbus	Vac	480	480	480	480	480	480	480	480	480	480	480	480
Continuous Torque for ΔT winding = 100 °C ①②③⑤	Nom	T _{CS}	Nm	2.85	2.87	2.86	5.04	5.08	5.12	6.97	6.97	6.98	8.48	8.51	8.47
			lb-in	25.2	25.4	25.3	44.6	45.0	45.3	61.7	61.7	61.8	75.0	75.3	75.0
Continuous Current for ΔT winding = 100 °C ①②③	Nom	I _{CS}	A _{RMS}	2.32	2.92	4.53	2.27	2.88	5.64	2.33	4.52	7.14	2.99	5.87	7.30
Continuous Torque for ΔT winding = 60 °C ②③⑤	Nom	T _{CS}	Nm	2.22	2.24	2.24	3.93	3.97	4.02	5.44	5.46	5.51	6.63	6.69	6.70
			lb-in	19.7	19.8	19.9	34.8	35.1	35.6	48.1	48.3	48.8	58.6	59.2	59.3
Max Mechanical Speed ④	Nom	N _{max}	rpm	6000	6000	6000	6000	6000	6000	6000	6000	6000	6000	6000	6000
Peak Torque ①②③	Nom	T _p	Nm	7.25	7.26	7.26	14.35	14.40	14.44	21.1	21.1	21.1	26.9	27.0	26.9
			lb-in	64.2	64.2	64.2	127.0	127.4	127.8	187	187	187	238	239	238
Peak Current	Nom	I _p	A _{RMS}	9.27	11.7	18.1	9.07	11.5	22.6	9.31	18.1	28.6	11.97	23.5	29.2
120 VAC Rated Torque (speed) ①②③		T _{rtd}	Nm	2.84	2.84	2.79	-	-	5.00	-	-	6.81	-	8.39	8.28
			lb-in	25.1	25.1	24.7	-	-	44.3	-	-	60.3	-	74.2	73.3
120 VAC Rated Speed		N _{rtd}	rpm	900	1200	2100	-	-	1500	-	-	1400	-	900	1200
120 VAC Rated Power (speed) ①②③		P _{rtd}	kW	0.267	0.357	0.613	-	-	0.79	-	-	1.00	-	0.79	1.04
			Hp	0.358	0.478	0.823	-	-	1.05	-	-	1.34	-	1.06	1.40
240 VAC Rated Torque (speed) ①②③		T _{rtd}	Nm	2.76	2.73	2.57	4.94	4.93	4.65	-	6.61	6.21	8.31	7.92	7.58
			lb-in	24.4	24.2	22.7	43.8	43.6	41.1	-	58.5	55.0	73.5	70.1	67.0
240 VAC Rated Speed		N _{rtd}	rpm	2100	2700	4500	1200	1600	3200	-	1900	3000	900	2000	2600
240 VAC Rated Power (speed) ①②③		P _{rtd}	kW	0.607	0.773	1.21	0.62	0.83	1.56	-	1.32	1.95	0.783	1.66	2.06
			Hp	0.814	1.04	1.62	0.83	1.11	2.09	-	1.76	2.62	1.05	2.22	2.77
400 VAC Rated Torque (speed) ①②③		T _{rtd}	Nm	2.62	2.52	2.28	4.79	4.71	3.87	6.67	6.10	4.83	7.99	6.98	6.04
			lb-in	23.2	22.3	20.1	42.4	41.7	34.3	59.0	54.0	42.7	70.7	61.8	53.4
400 VAC Rated Speed		N _{rtd}	rpm	3800	4800	6000	2100	2700	5600	1600	3200	5300	1700	3500	4500
400 VAC Rated Power (speed) ①②③		P _{rtd}	kW	1.04	1.27	1.43	1.05	1.33	2.27	1.12	2.05	2.68	1.42	2.56	2.84
			Hp	1.40	1.70	1.92	1.41	1.78	3.04	1.50	2.74	3.59	1.91	3.43	3.81
480 VAC Rated Torque (speed) ①②③		T _{rtd}	Nm	2.53	2.38	2.19	4.69	4.56	3.56	6.58	5.76	4.02	7.80	6.32	4.92
			lb-in	22.4	21.1	19.4	41.5	40.4	31.5	58.2	51.0	35.6	69.1	56.0	43.6
480 VAC Rated Speed		N _{rtd}	rpm	4600	5900	6000	2600	3300	6000	1900	3900	6000	2100	4300	5400
480 VAC Rated Power (speed) ①②③		P _{rtd}	kW	1.22	1.47	1.37	1.28	1.58	2.23	1.31	2.35	2.53	1.72	2.85	2.78
			Hp	1.63	1.97	1.84	1.71	2.11	3.00	1.75	3.15	3.39	2.30	3.82	3.73

Notes:

- ① Motor winding temperature rise, $\Delta T = 100$ °C, at 40 °C ambient.
- ② All data referenced to sinusoidal commutation.
- ③ Motor with resolver feedback and standard heat sink.
- ④ May be limited at some values of Vbus.
- ⑤ See de-rate curves for the de-rate of different motor options

AKM2G-4x Motor Parameters

Parameters	Tol	Symbol	Units	AKM2G-41			AKM2G-42			AKM2G-43			AKM2G-44		
				D	E	G	D	E	H	D	G	I	E	H	J
Torque Constant ①	±10%	K _t	Nm/A _{rms}	1.24	0.99	0.64	2.24	1.77	0.913	3.01	1.55	0.983	2.85	1.46	1.17
			lb-in/A _{rms}	11.0	8.76	5.64	19.8	15.7	8.1	26.7	13.7	8.7	25.2	12.9	10.3
Back EMF Constant ②	±10%	K _e	V _{rms} /k _r rpm	82.2	65.6	42.2	149.2	118.2	60.8	202	104	65.9	192	98.5	78.8
Motor Constant ③	Nom	K _m	N-m/√W	0.327	0.329	0.330	0.52	0.53	0.53	0.678	0.681	0.687	0.800	0.808	0.809
			lb-in/√W	2.89	2.91	2.92	4.63	4.67	4.73	6.00	6.03	6.08	7.08	7.15	7.16
Resistance (line-line) ②	±10%	R _m	Ohm	9.61	6.04	2.49	12.19	7.52	1.94	13.2	3.46	1.36	8.45	2.18	1.39
Inductance Q-Axis (line-line)		L _{qll}	mH	56.5	36.0	14.9	81.9	51.4	13.6	95.5	25.3	10.2	63.6	16.7	10.7
Inductance D-Axis (line-line)		L _{dll}	mH	Contact Factory	Contact Factory	Contact Factory	Contact Factory	Contact Factory	Contact Factory	Contact Factory	Contact Factory	Contact Factory	Contact Factory	Contact Factory	Contact Factory
Inductance Saturation Current		L _{isat}	Arms	11.9	15.0	23.3	13.4	16.9	32.9	15.0	29.1	45.9	21.0	41.0	51.3
Maximum Demagnetization Current		Midpeak	Arms	Contact Factory	Contact Factory	Contact Factory	Contact Factory	Contact Factory	Contact Factory	Contact Factory	Contact Factory	Contact Factory	Contact Factory	Contact Factory	Contact Factory
Inertia (includes Resolver feedback) ③	±10%	J _m	kg-cm ²	0.774			1.36			1.95			2.53		
			lb-in-s ²	6.85E-04			1.20E-03			1.72E-03			2.24E-03		
Optional Brake Inertia (additional)	±10%	J _m	kg-cm ²	0.360			0.36			0.36			0.360		
			lb-in-s ²	3.19E-04			3.19E-04			3.19E-04			3.19E-04		
Weight without brake ④		W	kg	2.90			3.86			4.81			5.76		
			lb	6.39			8.5			10.6			12.7		
Static Friction ⑤⑥		T _f	Nm	0.0230			0.030			0.0380			0.0450		
			lb-in	0.2036			0.27			0.336			0.398		
Viscous Damping ①		K _{dv}	Nm/k _r rpm	0.00450			0.009			0.0125			0.0163		
			lb-in/k _r rpm	0.0398			0.08			0.111			0.144		
Thermal Time Constant		TCT	minutes	17			22			27			32		
Coil Thermal Time Constant		MCT _{f0}		Contact Factory			Contact Factory			Contact Factory			Contact Factory		
Thermal Resistance ①		R _{thw-a}	K/W	0.880			0.725			0.637			0.598		
Pole Pairs		PP		5			5			5			5		
Heat Sink Size				10"x10"x1/4" Aluminum Plate			10"x10"x1/4" Aluminum Plate			10"x10"x1/4" Aluminum Plate			10"x10"x1/4" Aluminum Plate		

Notes:

- ① Motor winding temperature rise, ΔT = 100 °C, at 40 °C ambient.
- ② Measured at 25 °C.
- ③ Add parking brake if applicable for total inertia.
- ④ Brake motor adds 1.36 kg [3.0 lbs]
- ⑤ Shaft seal increases Static Friction by 0.023 Nm [0.20 lb-in]
- ⑥ This value is calculated from the Torque Constant and Resistance. Refer to those values and notes ① & ② for additional details.

AKM2G-4x Series Motor Specifications

AKM2G-4x De-rate Curves

Refer to the [Servo Motor Performance Curve Overview](#) section for additional details about Derate.

Example:

For an AKM2G-41 motor with an SFD feedback with shaft seal and no brake operating at 3000 RPM there is a 13.5% De-rate. Multiply the motor torque value (T_{CS}) by .865 for the rated torque at 3000 RPM. For ease of interpretation of the graph using a De-rate that is a rounded approximation is acceptable. For exact values refer to Kollmorgen's Motioneering Application Sizing programs, or the Kollmorgen website Performance Curve Generator.

Note: De-rates are referenced to the Continuous Torque ΔT wdg. = 100 °C.

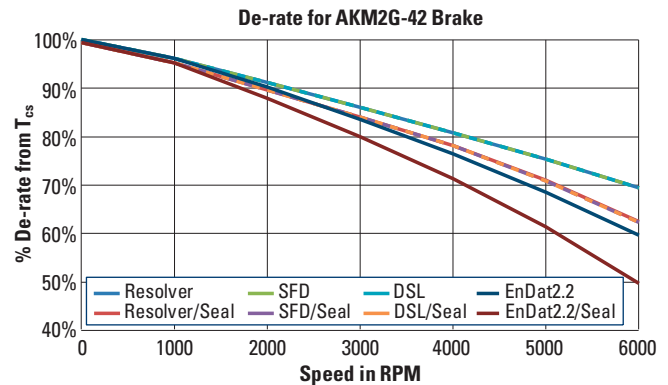
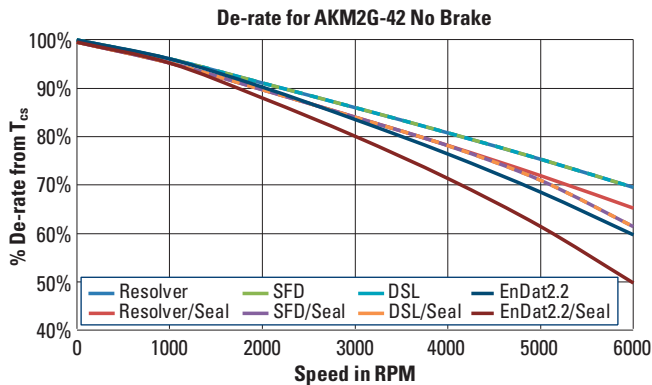
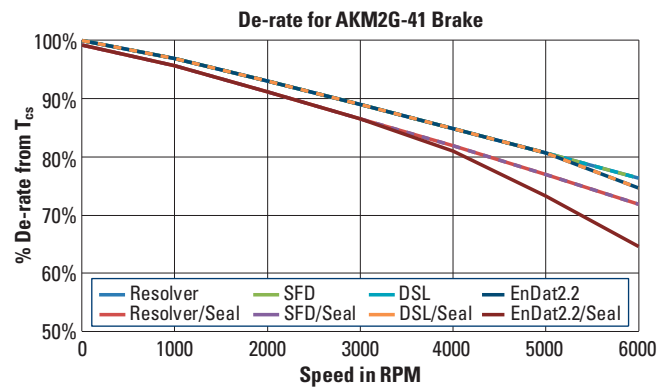
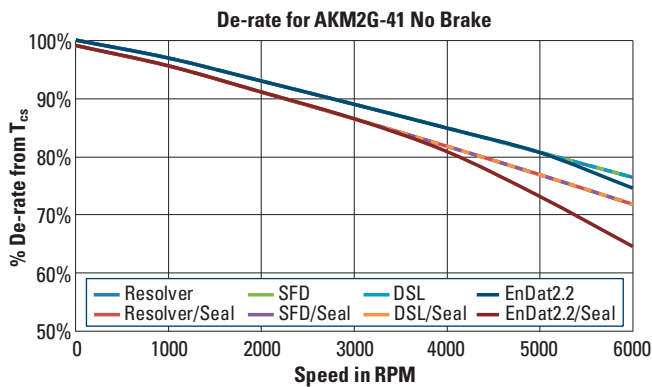

Continued on following page

⚠ IMPORTANT

Derate information for general estimation only. Use the on-line Performance Curve Generator located at <https://www.kollmorgen.com/en-us/service-and-support/technical/performance-curve-generator> for the most accurate information for your motor, or refer to Kollmorgen's Motioneering Online Tool located at <https://www.kollmorgen.com/en-us/service-and-support/technical/motioneering-online>

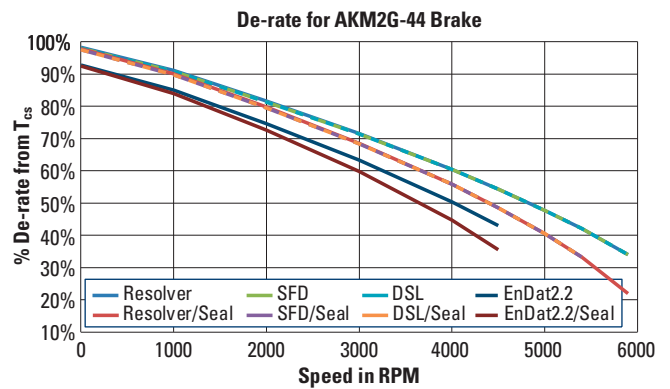
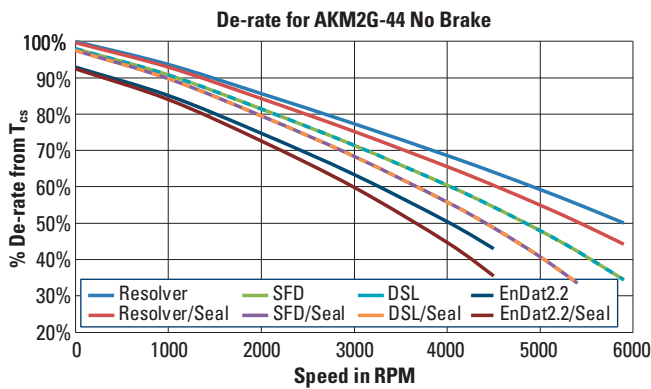
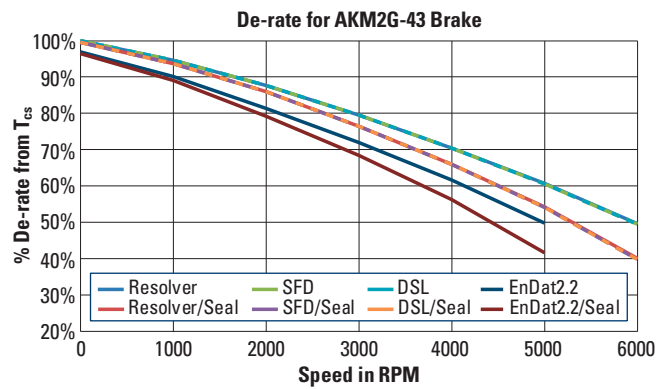
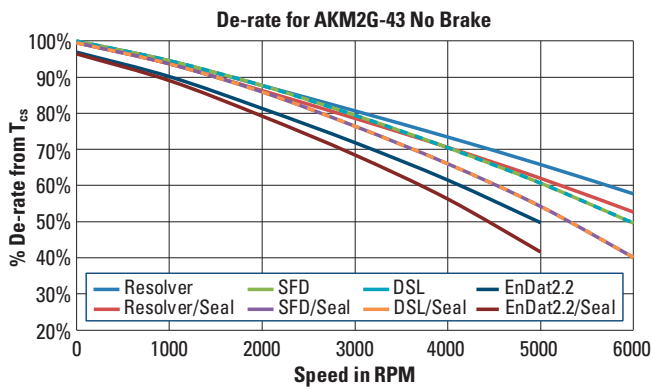

AKM2G-4x Series Motor Specifications

AKM2G-4x Dimensional Drawings and Data

AKM2G-4x A-, D- Single Connector Frame

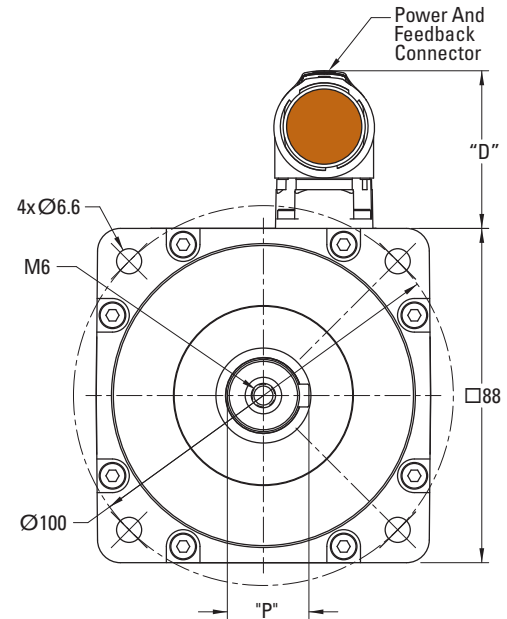
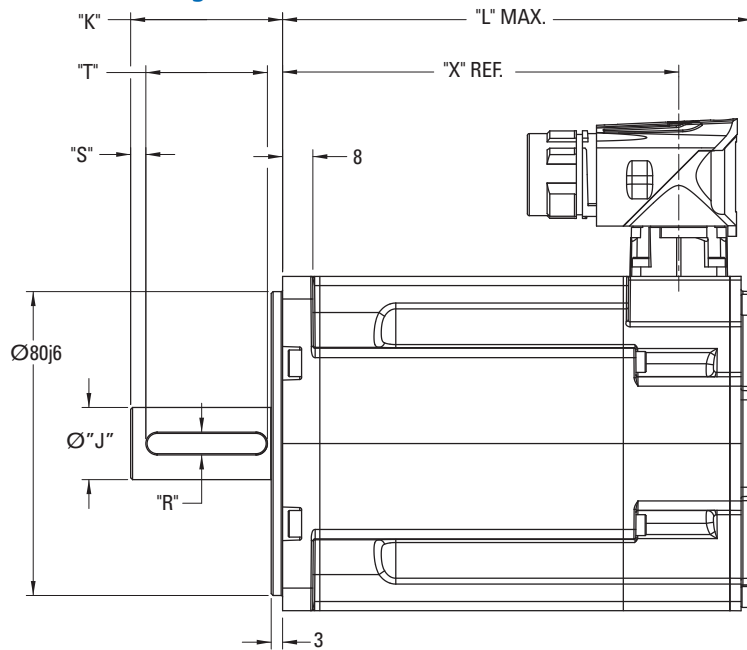

AKM2G-4x Mounting Flange-Shaft Dimensional Data

Mounting Flange-Shaft	Shaft Diameter	Shaft Length	Shaft Dia. w/ Key	Key Width	-	Key Length
	"J"	"K"	"P"	"R"	"S"	"T"
AC	19k6	40	21.5	6	4	32
AN	19k6	40	-	-	-	-
GC	14k6	30	16	5	5	20
GN	14k6	30	-	-	-	-

All dimensions in mm

AKM2G-4x Connector Height

Connector Feedback	"D"
SFD3 (CA), SFD-M	42.8
DSL (GU) & EnDat 2.2/22 (LD)	44.1

Note: Product designed in metric.

AKM2G-4x "X" and "L" Dimensions

Connector	No Brake (N)		
	"L" MAX		"X" REF
	A-, C-, D-	A-, C-, D-	A-, D-
Feedback Option	Cx, 2-, Ax, R-	Dx, GU, LD	Cx, 2-, Ax, Dx, GU, LD, R-
AKM2G-41	124.60	132.60	104.30
AKM2G-42	150.85	158.85	130.55
AKM2G-43	177.10	185.10	156.80
AKM2G-43	203.35	211.35	183.05
+ Brake ("2" option)	All AKM2G-4x: Add +47.80 mm to both "L" and "X" dimensions		

All dimensions in mm

AKM2G-4x A-, C- Dual Connector Option

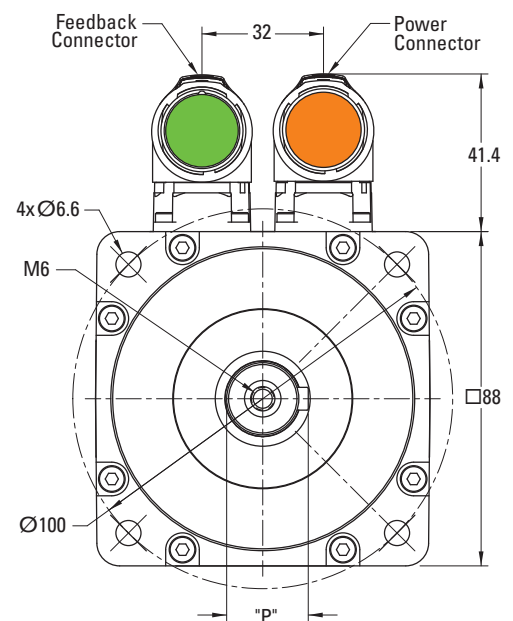

Related Topics:

[Feedback Options and Specifications](#)
[Connector Options and Pinouts](#)

Notes

AKM2G - Motor Series
- 4 - Frame Size
2 - Rotor Length
A - Winding Type
- A - Mount
N - Shaft
C - Connections
N - Brake
DA - Feedback
0 - Thermal Sensor
0 - Customization

A large grid area for taking notes, with a 0.125 inch division size.

0.125 inch divisions

AKM2G-5x Series Motor Specifications

AKM2G-5x Performance Data – Up to 480 Vac voltage

Parameters	Tol	Symbol	Units	AKM2G-51			AKM2G-52			AKM2G-53			AKM2G-54		
				H	I	K	H	K	L	H	L	M	L	M	N*
Max Rated Equivalent Line Voltage	Max	Vbus	Vac	480	480	400	480	480	400	480	480	400	480	480	400
Continuous Torque for ΔT winding = 100 °C ①②③⑤	Nom	T _{CS}	Nm	6.82	6.83	6.81	12.0	11.9	11.93	16.2	16.0	16.1	20.1	20.0	20.0
			lb-in	60.4	60.4	60.3	106	106	106	144	142	142	178	177	177
Continuous Current for ΔT winding = 100 °C ①②③	Nom	I _{CS}	A _{RMS}	5.78	6.35	10.2	6.30	10.0	12.5	5.69	12.5	14.2	10.6	14.5	16.3
Continuous Torque for ΔT winding = 60 °C ②③⑤	Nom	T _{CS}	Nm	5.33	5.35	5.36	9.40	9.43	9.42	12.7	12.7	12.7	15.9	15.9	15.9
			lb-in	47.2	47.3	47.4	83.2	83.4	83.4	113	113	112	141	141	141
Max Mechanical Speed ④	Nom	N _{max}	rpm	6000	6000	6000	6000	6000	6000	6000	6000	6000	6000	6000	6000
Peak Torque ①②③	Nom	T _p	Nm	15.7	15.7	15.7	29.0	29.0	28.9	41.8	41.4	41.4	54.8	54.7	54.7
			lb-in	139	139	139	257	256	256	370	366	367	485	484	484
Peak Current	Nom	I _p	A _{RMS}	17.3	19.0	30.5	18.9	30.1	37.6	17.1	37.6	42.5	31.7	43.9	48.8
120 VAC Rated Torque (speed) ①②③		T _{rtd}	Nm	6.73	6.72	6.54	-	11.7	11.5	-	15.6	15.4	-	19.3	19.1
			lb-in	59.6	59.5	57.9	-	103	102	-	138	136	-	171	169
120 VAC Rated Speed		N _{rtd}	rpm	1100	1200	2100	-	1200	1500	-	1100	1300	-	1100	1200
120 VAC Rated Power (speed) ①②③		P _{rtd}	kW	0.78	0.85	1.44	-	1.47	1.80	-	1.80	2.09	-	2.22	2.40
			Hp	1.04	1.13	1.93	-	1.97	2.42	-	2.41	2.81	-	2.98	3.22
240 VAC Rated Torque (speed) ①②③		T _{rtd}	Nm	6.44	6.38	5.77	11.5	10.8	10.2	15.7	14.1	13.5	18.4	17.2	16.5
			lb-in	57.0	56.5	51.1	102	95.6	90.4	139	124	120	163	152	146
240 VAC Rated Speed		N _{rtd}	rpm	2400	2700	4500	1500	2500	3200	1000	2400	2800	1600	2300	2600
240 VAC Rated Power (speed) ①②③		P _{rtd}	kW	1.62	1.80	2.72	1.80	2.83	3.42	1.65	3.53	3.97	3.09	4.13	4.49
			Hp	2.17	2.42	3.65	2.42	3.79	4.59	2.21	4.74	5.33	4.14	5.54	6.02
400 VAC Rated Torque (speed) ①②③		T _{rtd}	Nm	5.89	5.74	4.67	10.7	9.00	7.42	14.9	10.9	9.74	15.9	12.9	11.0
			lb-in	52.1	50.8	41.3	94.5	79.6	65.7	132	96.1	86.2	141	114	97.6
400 VAC Rated Speed		N _{rtd}	rpm	4200	4600	6000	2700	4400	5600	1800	4200	4800	2800	3900	4500
400 VAC Rated Power (speed) ①②③		P _{rtd}	kW	2.59	2.77	2.93	3.02	4.14	4.35	2.81	4.77	4.90	4.66	5.28	5.20
			Hp	3.47	3.71	3.94	4.05	5.56	5.83	3.77	6.40	6.57	6.25	7.08	6.97
480 VAC Rated Torque (speed) ①②③		T _{rtd}	Nm	5.53	5.29	-	10.3	7.81	-	14.4	8.64	-	14.3	9.80	-
			lb-in	49.0	46.8	-	90.7	69.1	-	128	76.5	-	126	86.7	-
480 VAC Rated Speed		N _{rtd}	rpm	5100	5700	-	3200	5300	-	2200	5100	-	3400	4800	-
480 VAC Rated Power (speed) ①②③		P _{rtd}	kW	2.96	3.16	-	3.44	4.34	-	3.32	4.61	-	5.08	4.92	-
			Hp	3.96	4.24	-	4.61	5.82	-	4.46	6.19	-	6.81	6.60	-

Notes:

① Motor winding temperature rise, ΔT = 100 °C, at 40 °C ambient.

② All data referenced to sinusoidal commutation.

③ Motor with resolver feedback and standard heat sink.

④ May be limited at some values of Vbus.

⑤ See de-rate curves for the de-rate of different motor options

* If compliance to UL 508 is required, then any winding above 16 Arms/Phase continuous current rating will not be compliant due to M23 ("A, C or D") connector limitations. Please contact Kollmorgen Customer Service for co-engineered solution evaluation.

AKM2G-5x Motor Parameters

Parameters	Tol	Symbol	Units	AKM2G-51			AKM2G-52			AKM2G-53			AKM2G-54		
				H	I	K	H	K	L	H	L	M	L	M	N*
Torque Constant ①	±10%	K _t	Nm/A _{rms}	1.19	1.08	0.674	1.91	1.20	0.956	2.87	1.29	1.14	1.91	1.38	1.24
			lb-in/A _{rms}	10.5	9.57	5.96	16.9	10.6	8.46	25.4	11.4	10.1	16.9	12.2	11.0
Back EMF Constant ②	±10%	K _e	V _{rms} /k _r rpm	80.2	73.1	45.6	129	80.9	64.7	194	87.1	77.1	130	93.3	83.8
Motor Constant ⑥	Nom	K _m	N-m/√W	0.637	0.638	0.640	1.02	1.03	1.03	1.32	1.32	1.32	1.57	1.57	1.57
			lb-in/√W	5.63	5.65	5.66	9.07	9.09	9.09	11.7	11.7	11.6	13.9	13.9	13.9
Resistance (line-line) ②	±10%	R _m	Ohm	2.31	1.91	0.740	2.32	0.902	0.578	3.15	0.635	0.500	0.991	0.514	0.416
Inductance Q-Axis (line-line)		L _{qll}	mH	20.8	17.2	6.70	24.5	9.6	6.1	35.5	7.15	5.60	11.6	6.0	4.9
Inductance D-Axis (line-line)		L _{dll}	mH	Contact Factory	Contact Factory	Contact Factory	Contact Factory	Contact Factory	Contact Factory	Contact Factory	Contact Factory	Contact Factory	Contact Factory	Contact Factory	Contact Factory
Inductance Saturation Current		L _{isat}	Arms	65.4	71.8	115.1	81	130	163	81.3	181	205	163	226	251
Maximum Demagnetization Current		Midpeak	Arms	Contact Factory	Contact Factory	Contact Factory	Contact Factory	Contact Factory	Contact Factory	Contact Factory	Contact Factory	Contact Factory	Contact Factory	Contact Factory	Contact Factory
Inertia (includes Resolver feedback) ③	±10%	J _m	kg-cm ²	2.52			4.58			6.64			8.70		
			lb-in-s ²	2.23E-03			4.06E-03			5.88E-03			7.70E-03		
Optional Brake Inertia (additional)	±10%	J _m	kg-cm ²	1.20			1.20			1.20			1.20		
			lb-in-s ²	1.06E-03			1.06E-03			1.06E-03			1.06E-03		
Weight without brake ④		W	kg	5.13			7.03			8.89			10.8		
			lb	11.3			15.5			19.6			23.8		
Static Friction ①⑤		T _f	Nm	0.0300			0.0560			0.0830			0.110		
			lb-in	0.266			0.496			0.735			0.974		
Viscous Damping ①		K _{dv}	Nm/k _r rpm	0.0125			0.0232			0.033			0.0427		
			lb-in/k _r rpm	0.111			0.205			0.292			0.378		
Thermal Time Constant		TCT	minutes	25			32			38			43		
Coil Thermal Time Constant		MCT _{f0}		Contact Factory			Contact Factory			Contact Factory			Contact Factory		
Thermal Resistance ①		R _{thw-a}	K/W	0.585			0.488			0.440			0.399		
Pole Pairs		PP		5			5			5			5		
Heat Sink Size				12"x12"x1/2" Aluminum Plate			12"x12"x1/2" Aluminum Plate			12"x12"x1/2" Aluminum Plate			12"x12"x1/2" Aluminum Plate		

Notes:

① Motor winding temperature rise, ΔT = 100 °C, at 40 °C ambient.

② Measured at 25 °C.

③ Add parking brake if applicable for total inertia.

④ Brake motor adds 2.6 kg [5.7 lbs]

⑤ Shaft seal increases Static Friction by 0.07 Nm [0.62 lb-in]

⑥ This value is calculated from the Torque Constant and Resistance. Refer to those values and notes ① & ② for additional details.

* If compliance to UL 508 is required, then any winding above 16 Arms/Phase continuous current rating will not be compliant due to M23 ("A, C or D") connector limitations. Please contact Kollmorgen Customer Service for co-engineered solution evaluation.

AKM2G-5x Series Motor Specifications

AKM2G-5x De-rate Curves

Refer to the [Servo Motor Performance Curve Overview](#) section for additional details about Derate.

Example:

For an AKM2G-51 motor with an SFD feedback with shaft seal and no brake operating at 3000 RPM there is a 19.1% De-rate. Multiply the motor torque value (T_{CS}) by .809 for the rated torque at 3000 RPM. For ease of interpretation of the graph using a De-rate that is a rounded approximation is acceptable. For exact values refer to Kollmorgen's Motioneering Application Sizing programs, or the Kollmorgen website Performance Curve Generator.

Note: De-rates are referenced to the Continuous Torque ΔT wdg. = 100 °C.

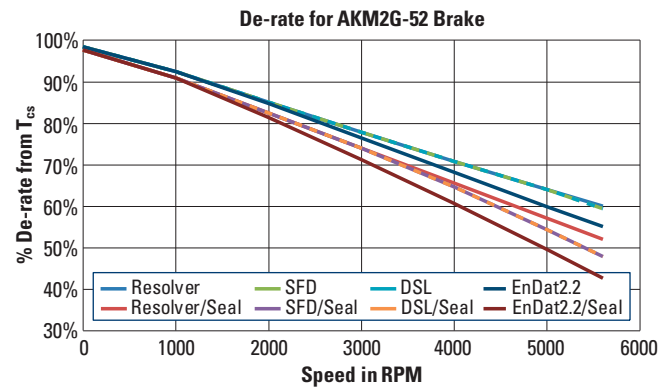
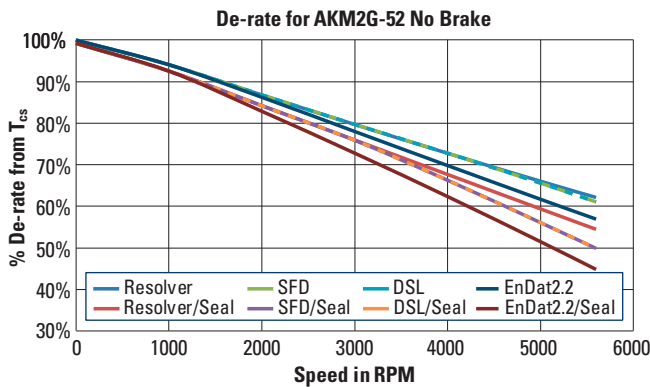
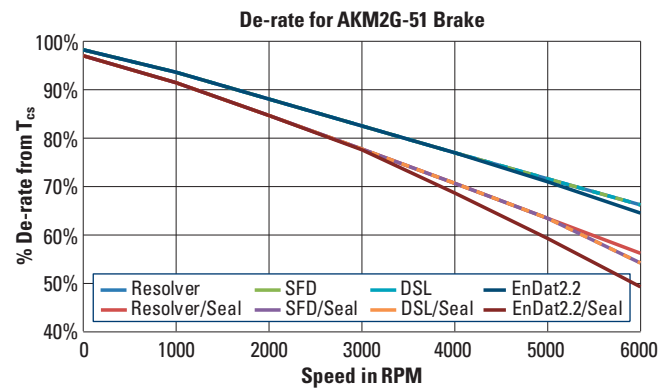
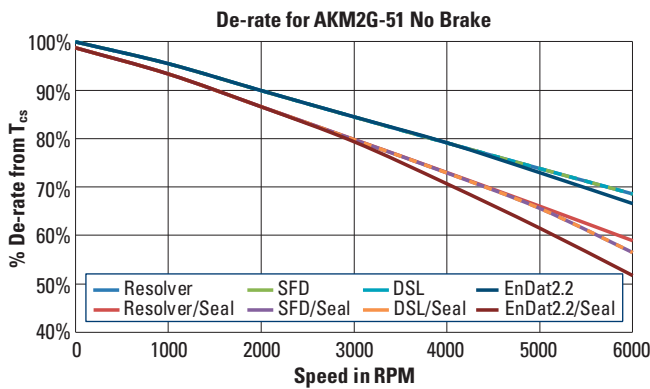

Continued on following page

⚠ IMPORTANT

Derate information for general estimation only. Use the on-line Performance Curve Generator located at <https://www.kollmorgen.com/en-us/service-and-support/technical/performance-curve-generator> for the most accurate information for your motor, or refer to Kollmorgen's Motioneering Online Tool located at <https://www.kollmorgen.com/en-us/service-and-support/technical/motioneering-online>

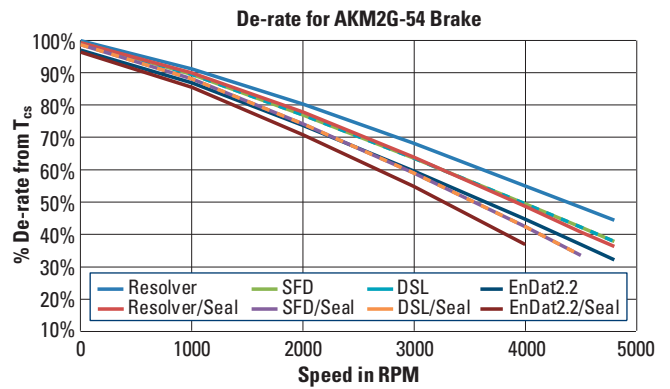
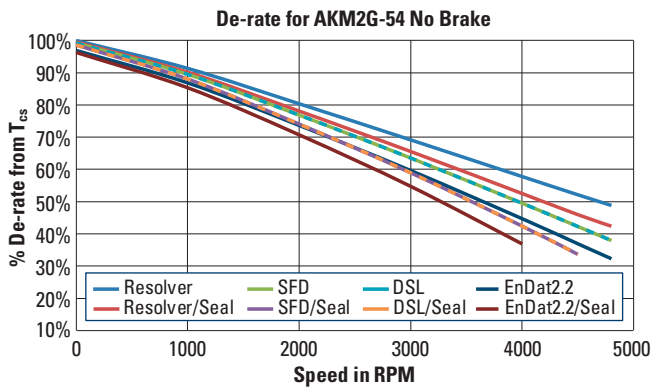
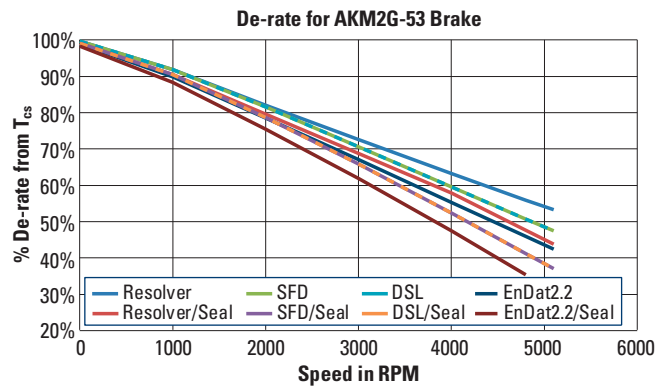
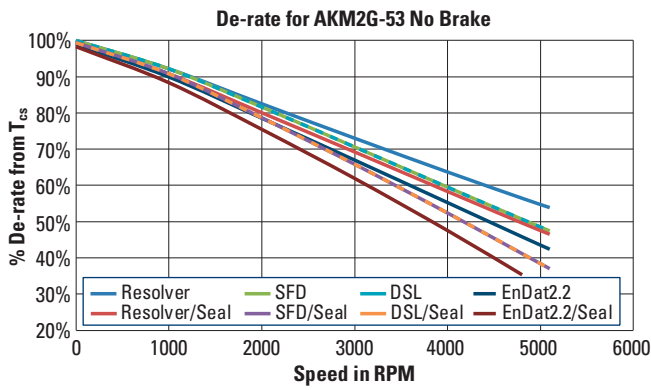

AKM2G-5x Series Motor Specifications

AKM2G-5x Dimensional Drawings and Data

AKM2G-5x A-, D- Single Connector Frame

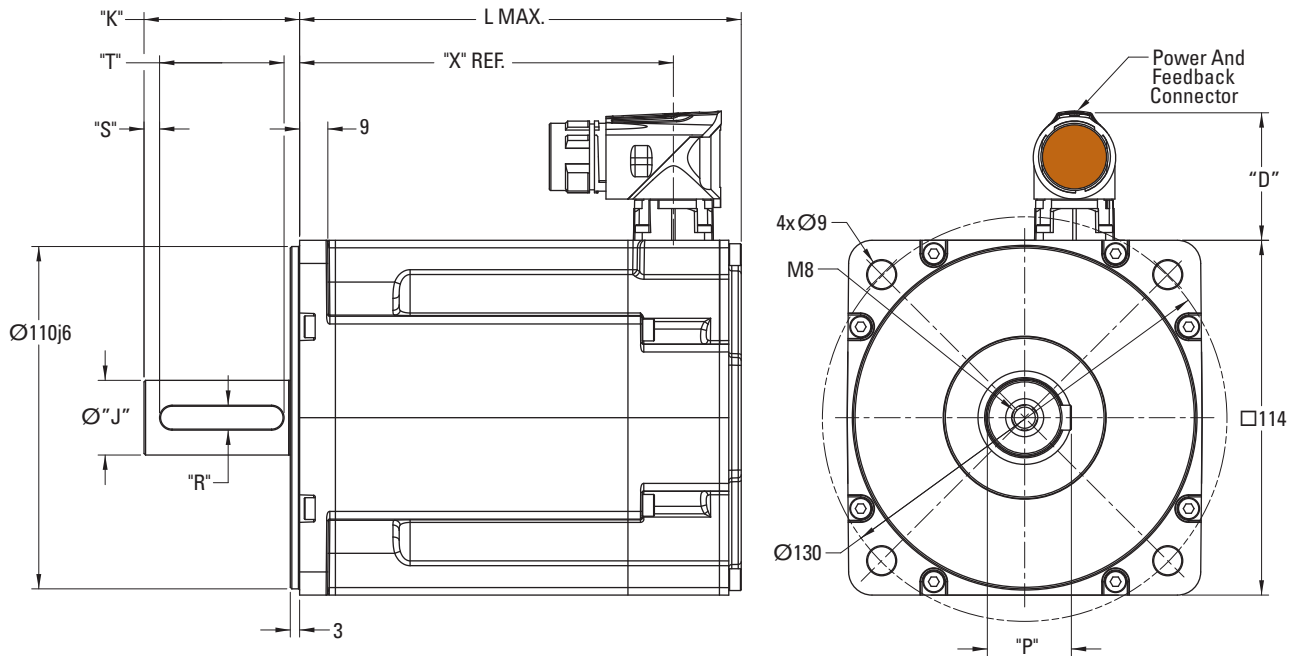

AKM2G-5x Mounting Flange-Shaft Dimensional Data

Mounting Flange-Shaft	Shaft Diameter	Shaft Length	Shaft Dia. w/ Key	Key Width	-	Key Length
	"J"	"K"	"P"	"R"	"S"	"T"
AC	24k6	50	27	8	5	40
AN	24k6	50	-	-	-	-
GC	19k6	40	21.5	6	4	32
GN	19k6	40	-	-	-	-

All dimensions in mm

AKM2G-5x Connector Height

Connector Feedback	"D"
SFD3 (CA), SFD-M	42.8
DSL (GU) & EnDat 2.2/22 (LD)	44.1

Note: Product designed in metric.

AKM2G-5x A-, C- Dual Connector Option

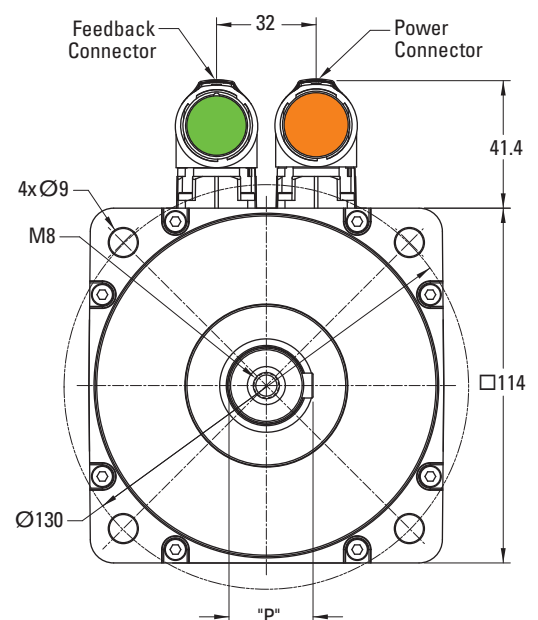

AKM2G-5x "X" and "L" Dimensions

Connector	No Brake (N)			
	"L" MAX		"X" REF	
Connector	A-, C-, D-	D-	A-, C-	A-, C-, D-
Feedback Option	Cx, 2-, R-	GU, LD	Ax, Dx	All
AKM2G-51	142.80	132.60	163.90	120.10
AKM2G-52	172.20	158.85	193.30	149.50
AKM2G-53	201.60	185.10	222.70	178.90
AKM2G-54	231.00	211.35	252.10	208.30
+ Brake ("2" option)	All AKM2G-5x: Add +57.00 mm to both "L" and "X" dimensions			

All dimensions in mm

Related Topics:

[Feedback Options and Specifications](#)
[Connector Options and Pinouts](#)

Notes

AKM2G - 5 2 A - A N C N DA 0 0
Motor Series Frame Size Rotor Length Winding Type Mount Shaft Connections Brake Feedback Thermal Sensor Customization

A large grid area for taking notes, with a 0.125 inch division size.

0.125 inch divisions

AKM2G-6x Series Motor Specifications

AKM2G-6x Performance Data – Up to 480 Vac voltage

Parameters	Tol	Symbol	Units	AKM2G-62			AKM2G-63				AKM2G-64			AKM2G-65		
				K	L	M	H	K	M	N*	L	M	N*	L	M	N*
Max Rated Equivalent Line Voltage	Max	Vbus	Vac	480	480	400	480	480	480	400	480	480	480	480	480	480
Continuous Torque for ΔT winding = 100 °C ①②③⑤	Nom	T _{CS}	Nm	15.3	15.2	15.1	21.7	21.5	21.4	21.4	27.0	26.9	26.8	32.6	32.6	32.7
			lb-in	135	134	134	192	190	189	189	239	238	237	289	289	289
Continuous Current for ΔT winding = 100 °C ①②③	Nom	I _{CS}	A _{RMS}	9.32	11.6	14.6	6.11	9.79	15.2	16.8	11.4	15.8	17.8	12.4	15.3	19.0
Continuous Torque for ΔT winding = 60 °C ②③⑤	Nom	T _{CS}	Nm	12.0	12.0	11.9	17.0	16.9	16.9	16.9	21.3	21.3	21.2	25.8	25.8	25.9
			lb-in	106	106	106	150	150	149	149	188	188	188	228	228	230
Max Mechanical Speed ④	Nom	N _{max}	rpm	6000	6000	6000	6000	6000	6000	6000	6000	6000	6000	6000	6000	
Peak Torque ①②③	Nom	T _p	Nm	37.6	37.4	37.4	55.1	54.7	54.5	54.5	70.7	70.5	70.3	86.8	86.8	87.0
			lb-in	332	331	331	487	484	482	482	626	624	622	768	768	770
Peak Current	Nom	I _p	A _{RMS}	28.0	34.9	43.7	18.3	29.4	45.5	50.5	34.1	47.5	53.3	37.1	45.9	56.9
Rated Torque (speed) ①②③		T _{Rtd}	Nm	-	14.9	14.6	-	-	20.9	20.7	-	-	26.2	-	-	-
			lb-in	-	132	130	-	-	185	183	-	-	232	-	-	-
Rated Speed		N _{Rtd}	rpm	-	1000	1300	-	-	1000	1100	-	-	900	-	-	-
Rated Power (speed) ①②③		P _{Rtd}	kW	-	1.56	1.99	-	-	2.19	2.39	-	-	2.47	-	-	-
			Hp	-	2.09	2.67	-	-	2.93	3.20	-	-	3.32	-	-	-
Rated Torque (speed) ①②③		T _{Rtd}	Nm	14.4	13.8	13.1	21.5	20.5	19.2	18.7	25.7	24.6	23.8	31.1	30.3	29.5
			lb-in	127	122	116	191	181	170	166	227	217	211	275	268	261
Rated Speed		N _{Rtd}	rpm	1700	2200	2800	750	1300	2100	2300	1200	1700	2000	1100	1400	1700
Rated Power (speed) ①②③		P _{Rtd}	kW	2.56	3.19	3.85	1.69	2.79	4.21	4.51	3.23	4.37	4.98	3.58	4.44	5.25
			Hp	3.43	4.27	5.16	2.27	3.74	5.65	6.05	4.33	5.86	6.68	4.80	5.96	7.04
Rated Torque (speed) ①②③		T _{Rtd}	Nm	12.9	11.5	9.6	20.6	18.9	15.6	14.1	23.4	20.5	18.9	28.5	26.7	23.6
			lb-in	114	102	85	182	167	138	125	207	182	167	252	236	209
Rated Speed		N _{Rtd}	rpm	3000	3900	5000	1300	2200	3600	4100	2100	3000	3400	1900	2400	3100
Rated Power (speed) ①②③		P _{Rtd}	kW	4.05	4.70	5.03	2.80	4.35	5.88	6.07	5.15	6.45	6.72	5.67	6.71	7.67
			Hp	5.42	6.31	6.74	3.75	5.84	7.89	8.14	6.91	8.65	9.01	7.60	8.99	10.28
Rated Torque (speed) ①②③		T _{Rtd}	Nm	11.9	9.84	-	20.1	17.8	12.84	-	21.9	17.7	15.2	26.8	24.3	19.6
			lb-in	105	87.1	-	178	158	113.7	-	194	156.3	134	237	215	173
Rated Speed		N _{Rtd}	rpm	3700	4800	-	1600	2700	4500	-	2600	3700	4200	2300	2900	3800
Rated Power (speed) ①②③		P _{Rtd}	kW	4.59	4.95	-	3.37	5.03	6.05	-	5.95	6.84	6.67	6.46	7.38	7.79
			Hp	6.16	6.63	-	4.52	6.75	8.12	-	7.98	9.18	8.95	8.67	9.90	10.44

Notes:

① Motor winding temperature rise, ΔT = 100 °C, at 40 °C ambient.

② All data referenced to sinusoidal commutation.

③ Motor with resolver feedback and standard heat sink.

④ May be limited at some values of Vbus.

⑤ See de-rate curves for the de-rate of different motor options

* If compliance to UL 508 is required, then any winding above 16 Arms/Phase continuous current rating, requires M40 “E”, “H” or “J” connector. Please contact Kollmorgen Customer Service for co-engineered solution evaluation.

AKM2G-6x Motor Parameters

Parameters	Tol	Symbol	Units	AKM2G-62				AKM2G-63				AKM2G-64			AKM2G-65		
				K	L	M	H	K	M	N*	L	M	N*	L	M	N*	
Torque Constant ①	±10%	K _t	Nm/A _{rms}	1.64	1.31	1.04	3.56	2.20	1.41	1.27	2.38	1.70	1.51	2.65	2.14	1.73	
			lb-in/A _{rms}	14.5	11.6	9.2	31.5	19.5	12.5	11.3	21.1	15.1	13.4	23.4	18.9	15.3	
Back EMF Constant ②	±10%	K _e	V _{rms} /k _r rpm	111	88.3	70.3	240	149	95.5	86.0	161	115.2	102.4	179	144	117	
Motor Constant ⑥	Nom	K _m	N-m/√W	1.25	1.25	1.24	1.66	1.65	1.65	1.65	1.99	1.98	1.98	2.28	2.29	2.30	
			lb-in/√W	11.1	11.0	11.0	14.7	14.6	14.6	14.6	17.6	17.6	17.5	20.2	20.2	20.4	
Resistance (line-line) ②	±10%	R _m	Ohm	1.15	0.732	0.468	3.07	1.18	0.491	0.398	0.955	0.491	0.389	0.896	0.584	0.378	
Inductance Q-Axis (line-line)		L _{qll}	mH	17.4	11.0	7.0	51.6	19.8	8.2	6.6	16.9	8.7	6.8	16.4	10.7	7.0	
Inductance D-Axis (line-line)		L _{dll}	mH	Contact Factory	Contact Factory	Contact Factory	Contact Factory	Contact Factory	Contact Factory	Contact Factory	Contact Factory	Contact Factory	Contact Factory	Contact Factory	Contact Factory	Contact Factory	
Inductance Saturation Current		L _{isat}	Arms	250	314	394	175	282	439	488	349	488	549	394	488	603	
Maximum Demagnetization Current		Midpeak	Arms	Contact Factory	Contact Factory	Contact Factory	Contact Factory	Contact Factory	Contact Factory	Contact Factory	Contact Factory	Contact Factory	Contact Factory	Contact Factory	Contact Factory	Contact Factory	
Inertia (includes Resolver feedback) ③	±10%	J _m	kg-cm ²	9.10				13.0				16.9			20.8		
			lb-in-s ²	8.05E-03				1.15E-02				1.49E-02			1.84E-02		
Optional Brake Inertia (additional)	±10%	J _m	kg-cm ²	3.60				3.60				3.60			3.60		
			lb-in-s ²	3.19E-03				3.19E-03				3.19E-03			3.19E-03		
Weight without brake ④		W	kg	10.0				12.3				14.5			16.8		
			lb	22.0				27.0				32.0			37.0		
Static Friction ①⑤		T _f	Nm	0.0400				0.060				0.0800			0.100		
			lb-in	0.354				0.531				0.708			0.885		
Viscous Damping ①		K _{dv}	Nm/k _r rpm	0.0370				0.053				0.0680			0.0840		
			lb-in/k _r rpm	0.327				0.469				0.602			0.743		
Thermal Time Constant		TCT	minutes	40				50				60			75		
Coil Thermal Time Constant		MCT _{f0}		Contact Factory				Contact Factory				Contact Factory			Contact Factory		
Thermal Resistance ①		R _{thw-a}	K/W	0.448				0.393				0.359			0.324		
Pole Pairs		PP		5				5				5			5		
Heat Sink Size				18"x18"x1/2" Aluminum Plate				18"x18"x1/2" Aluminum Plate				18"x18"x1/2" Aluminum Plate			18"x18"x1/2" Aluminum Plate		

Notes:

- ① Motor winding temperature rise, ΔT = 100 °C, at 40 °C ambient.
- ② Measured at 25 °C.
- ③ Add parking brake if applicable for total inertia.
- ④ Brake motor adds 4.5 kg [10.0 lbs]
- ⑤ Shaft seal increases Static Friction by 0.12 Nm [1.06 lb-in]
- ⑥ This value is calculated from the Torque Constant and Resistance. Refer to those values and notes ① & ② for additional details.
- * If compliance to UL 508 is required, then any winding above 16 Arms/Phase continuous current rating, requires M40 "E", "H" or "J" connector. Please contact Kollmorgen Customer Service for co-engineered solution evaluation.

AKM2G-6x Series Motor Specifications

AKM2G-6x De-rate Curves

Refer to the [Servo Motor Performance Curve Overview](#) section for additional details about Derate.

Example:

For an AKM2G-62 motor with an SFD feedback with shaft seal and no brake operating at 3000 RPM there is a 25.8% De-rate. Multiply the motor torque value (T_{CS}) by .742 for the rated torque at 3000 RPM. For ease of interpretation of the graph using a De-rate that is a rounded approximation is acceptable. For exact values refer to Kollmorgen's Motioneering Application Sizing programs, or the Kollmorgen website Performance Curve Generator.

Note: De-rates are referenced to the Continuous Torque ΔT wdg. = 100 °C.

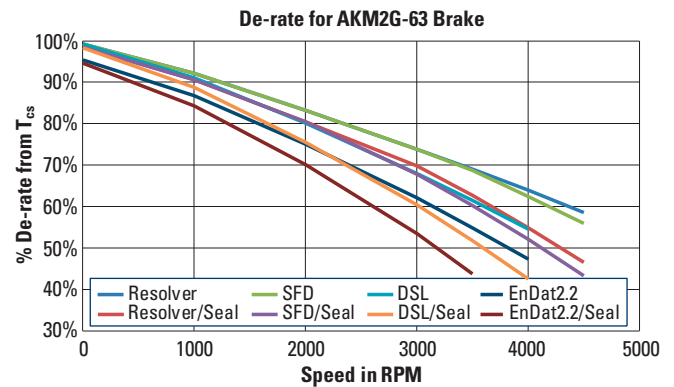
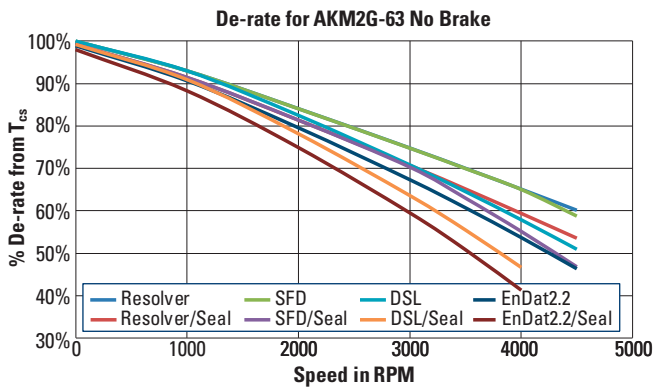
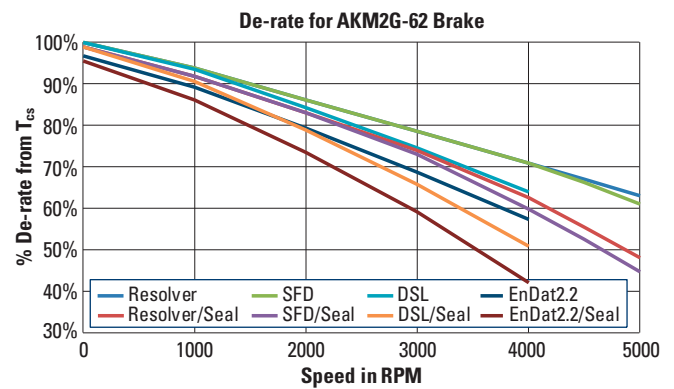
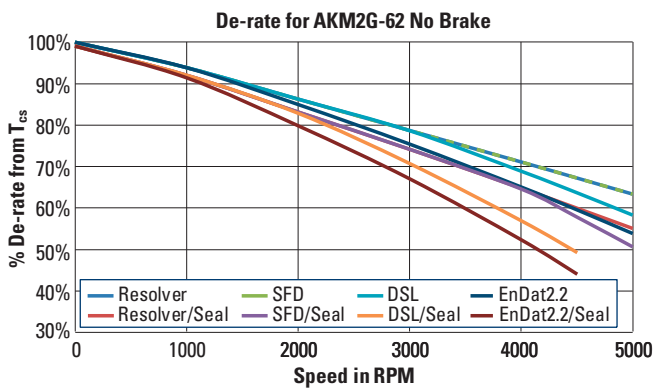

Continued on following page

⚠ IMPORTANT

Derate information for general estimation only. Use the on-line Performance Curve Generator located at <https://www.kollmorgen.com/en-us/service-and-support/technical/performance-curve-generator> for the most accurate information for your motor, or refer to Kollmorgen's Motioneering Online Tool located at <https://www.kollmorgen.com/en-us/service-and-support/technical/motioneering-online>

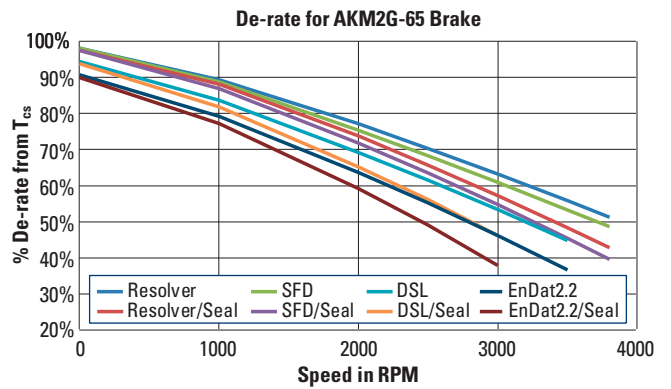
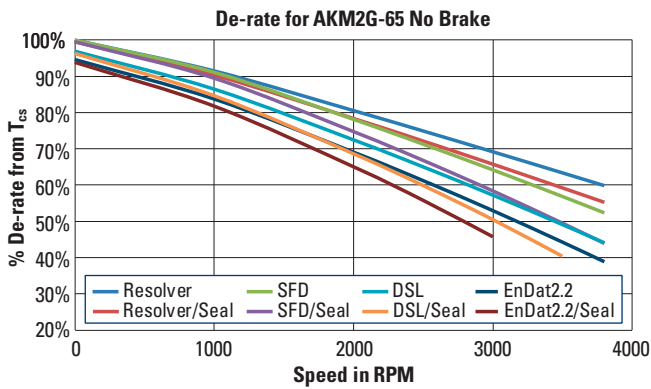
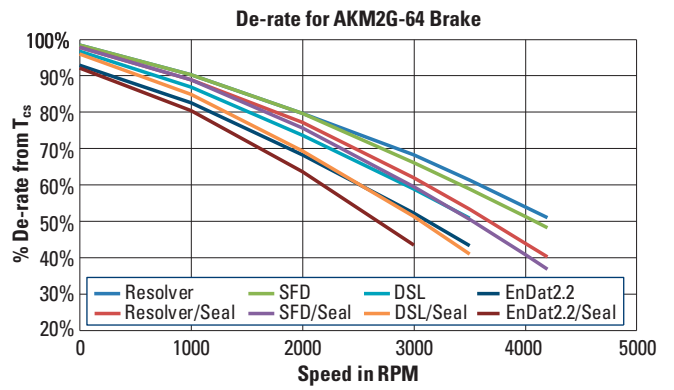
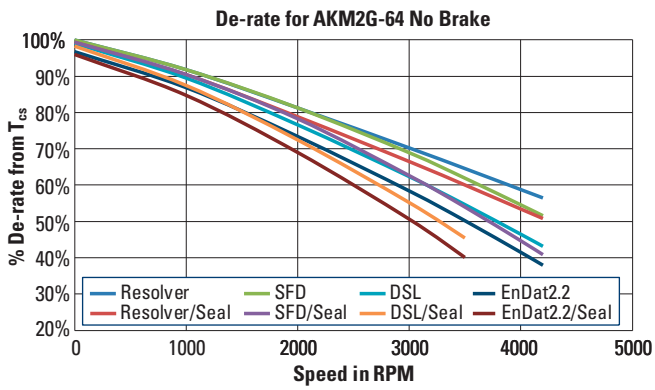

AKM2G-6x Series Motor Specifications

AKM2G-6x Dimensional Drawings and Data

AKM2G-6x A-, D- Single Connector Frame

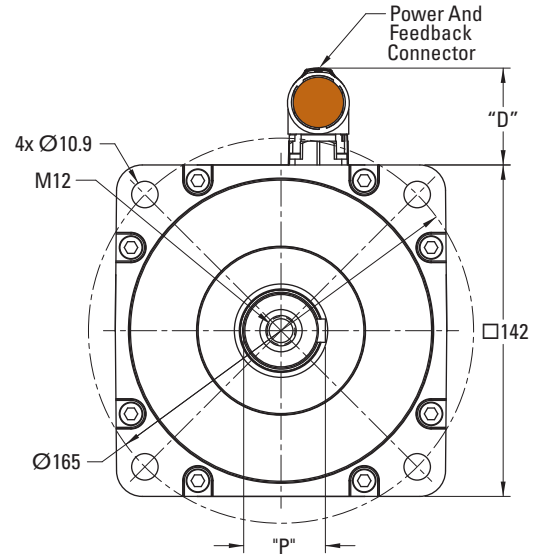
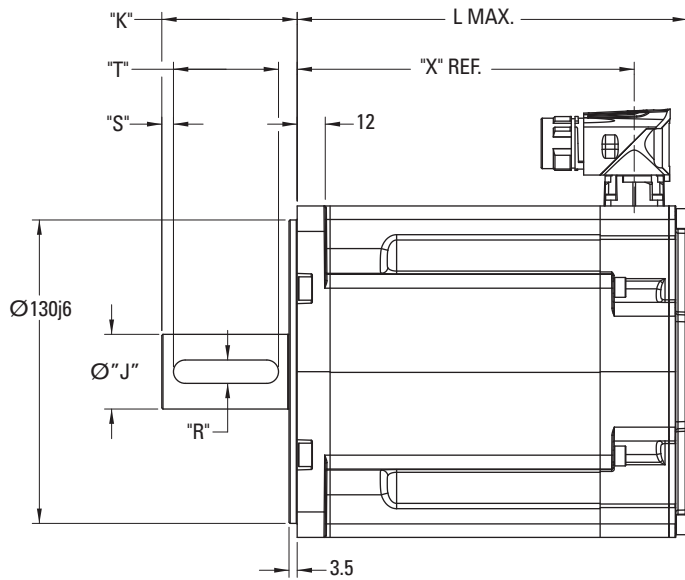

AKM2G-6x Mounting Flange-Shaft Dimensional Data

Mounting Flange-Shaft	Shaft Diameter	Shaft Length	Shaft Dia. w/ Key	Key Width	-	Key Length
	"J"	"K"	"P"	"R"	"S"	"T"
AC	32k6	58	35	10	5	45
AN	32k6	58	-	-	-	-
GC	24k6	50	27	8	5	40
GN	24k6	50	-	-	-	-

All dimensions in mm

AKM2G-6x Connector Height

Connector Feedback	"D"
SFD3 (CA), SFD-M	42.8
DSL (GU) & EnDat 2.2/22 (LD)	44.1

AKM2G-6x "X" and "L" Dimensions

Connector	No Brake (N)			"X" REF
	"L" MAX			
	A-, C-, D-	D-	A-, C-	A-, C-, D-
Feedback Option	Cx, 2-, R-	GU, LD	Ax, Dx	All
AKM2G-62	168.10	178.40	189.20	144.40
AKM2G-63	190.15	200.45	211.25	166.45
AKM2G-64	212.20	222.50	233.30	288.50
AKM2G-65	234.25	244.55	255.35	210.55
+ Brake ("2" option)	All AKM2G-6x: Add +65.70 mm to both "L" and "X" dimensions			

All dimensions in mm

Note: Product designed in metric.

Related Topics:

[Feedback Options and Specifications](#)
[Connector Options and Pinouts](#)

AKM2G-6x A-, C- Dual Connector Option

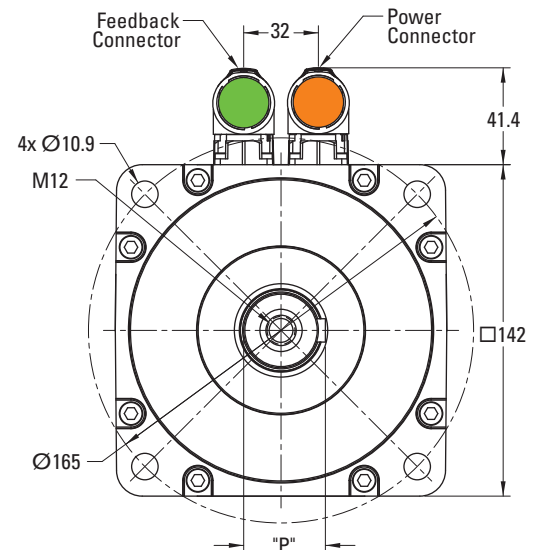

Notes

AKM2G - 6 2 A - A N C N DA 0 0
Motor Series Rotor Length Frame Size Winding Type Mount Shaft Connections Brake Feedback Thermal Sensor Customization

A large grid area for taking notes, with a 0.125 inch division size.

0.125 inch divisions

AKM2G-7x Series Motor Specifications

AKM2G-7x Performance Data – Up to 480 Vac voltage

Parameters	Tol	Symbol	Units	AKM2G-71			AKM2G-72				AKM2G-73			AKM2G-74		
				L	N*	P	L	N*	P	R	L	N*	Q	P	Q	R
Max Rated Equivalent Line Voltage	Max	V _{bus}	Vac	480	480	400	480	480	480	240	480	480	480	480	480	480
Continuous Torque for ΔT winding = 100°C ①②③⑤	Nom	T _{CS}	Nm	22.9	22.8	23.0	40.5	41.1	40.7	40.5	56.6	57.9	57.1	72.2	71.7	71.3
			lb-in	202	201	204	359	364	360	359	501	512	505	639	635	631
Continuous Current for ΔT winding = 100°C ①②③	Nom	I _{CS}	A _{RMS}	12.1	17.3	21.1	12.3	18.7	21.2	37.0	11.6	17.6	27.4	23.1	28.8	32.5
Continuous Torque for ΔT winding = 60°C ②③⑤	Nom	T _{CS}	Nm	18.0	18.0	18.2	32.0	32.7	32.4	32.2	44.7	45.9	45.6	57.7	57.7	57.5
			lb-in	160	160	161	284	289	287	285	396	406	404	511	510	509
Max Mechanical Speed ④	Nom	N _{max}	rpm	6000	6000	6000	6000	6000	6000	6000	6000	6000	6000	6000	6000	6000
Peak Torque ①②③	Nom	T _p	Nm	49.5	49.3	49.8	89.3	90.4	89.6	89.4	127.3	129.6	128.1	164.6	163.8	162.9
			lb-in	438	436	440	791	800	793	791	1127	1147	1134	1457	1450	1442
Peak Current	Nom	I _p	A _{RMS}	30.2	43.3	52.8	30.8	46.9	53.0	92.4	29.0	43.9	68.5	57.8	72.1	81.1
120 VAC	Rated Torque (speed) ①②③	T _{Rtd}	Nm	-	22.0	21.9	-	-	-	-	-	-	-	-	-	-
			lb-in	-	195	193	-	-	-	-	-	-	-	-	-	-
120 VAC	Rated Speed	N _{Rtd}	rpm	-	1050	1300	-	-	-	-	-	-	-	-	-	-
			Rated Power (speed) ①②③	P _{Rtd}	kW	-	2.42	2.97	-	-	-	-	-	-	-	-
			Hp		-	3.25	3.99	-	-	-	-	-	-	-	-	-
240 VAC	Rated Torque (speed) ①②③	T _{Rtd}	Nm	21.2	19.9	19.0	38.7	37.4	36.1	28.6	-	54.6	50.0	66.5	64.0	61.5
			lb-in	188	176	168	342	331	319	253	-	484	442	589	566	544
240 VAC	Rated Speed	N _{Rtd}	rpm	1500	2200	2700	900	1400	1600	2800	-	900	1500	1000	1250	1450
			Rated Power (speed) ①②③	P _{Rtd}	kW	3.34	4.58	5.36	3.64	5.48	6.05	8.38	-	5.15	7.85	6.96
					Hp	4.47	6.14	7.19	4.89	7.35	8.11	11.2	-	6.91	10.5	9.34
400 VAC	Rated Torque (speed) ①②③	T _{Rtd}	Nm	19.0	15.2	12.1	36.1	31.9	29.0	-	52.5	49.5	38.9	58.1	50.7	45.1
			lb-in	168	135	107	319	283	257	-	465	438	344	514	448	399
400 VAC	Rated Speed ⑥	N _{Rtd}	rpm	2600	4000	4900	1550	2400	2800	-	1050	1600	2600	1700	2200	2500
			Rated Power (speed) ①②③	P _{Rtd}	kW	5.17	6.38	6.18	5.86	8.03	8.51	-	5.77	8.29	10.6	10.3
					Hp	6.94	8.55	8.29	7.85	10.8	11.4	-	7.74	11.1	14.2	13.9
480 VAC	Rated Torque (speed) ①②③	T _{Rtd}	Nm	17.5	12.0	-	34.2	28.4	24.2	-	50.6	46.6	30.8	52.4	41.7	34.0
			lb-in	155	106	-	303	251	215	-	448	412	273	464	369	301
480 VAC	Rated Speed ⑥	N _{Rtd}	rpm	3200	4900	-	1900	2900	3400	-	1300	1900	3200	2100	2700	3000
			Rated Power (speed) ①②③	P _{Rtd}	kW	5.87	6.14	-	6.81	8.63	8.6	-	6.89	9.3	10.3	11.5
					Hp	7.87	8.23	-	9.13	11.6	11.6	-	9.24	12.4	13.9	15.5

Notes:

① Motor winding temperature rise, ΔT = 100 °C, at 40 °C ambient.

② All data referenced to sinusoidal commutation.

③ Motor with resolver feedback and standard heat sink.

④ May be limited at some values of V_{bus}.

⑤ See de-rate curves for the de-rate of different motor options

⑥ Rated speed for motors equipped with a brake are limited to 3500 RPM.

* If compliance to UL 508 is required, then any winding above 16 Arms/Phase continuous current rating, requires M40 “E”, “H” or “J” connector. Please contact Kollmorgen Customer Service for co-engineered solution evaluation.

AKM2G-7x Motor Parameters

Parameters	Tol	Symbol	Units	AKM2G-71			AKM2G-72				AKM2G-73			AKM2G-74		
				L	N*	P	L	N*	P	P	L	N*	Q	P	Q	R
Torque Constant ①	±10%	K _t	Nm/A _{rms}	1.90	1.32	1.10	3.31	2.20	1.93	1.10	4.90	3.30	2.09	3.14	2.50	2.21
			lb-in/A _{rms}	16.9	11.7	9.7	29.3	19.5	17.0	9.8	43.3	29.2	18.5	27.8	22.1	19.5
Back EMF Constant ②	±10%	K _e	V _{rms} /k _r rpm	127	88.3	73.3	221	147	129	73.6	328	221	140	210	167	148
Motor Constant ⑥	Nom	K _m	N-m/√W	1.69	1.69	1.71	2.77	2.83	2.80	2.79	3.59	3.68	3.66	4.39	4.38	4.37
			lb-in/√W	15.0	15.0	15.2	24.5	25.0	24.8	24.7	31.7	32.6	32.4	38.8	38.8	38.7
Resistance (line-line) ②	±10%	R _m	Ohm	0.845	0.407	0.274	0.950	0.405	0.315	0.104	1.24	0.537	0.217	0.341	0.217	0.170
Inductance Q-Axis (line-line)		L _{qll}	mH	17.6	8.5	5.8	22.6	10.0	7.7	2.5	31.2	14.2	5.7	9.2	5.9	4.6
Inductance D-Axis (line-line)		L _{dll}	mH	Contact Factory	Contact Factory	Contact Factory	Contact Factory	Contact Factory	Contact Factory	Contact Factory	Contact Factory	Contact Factory	Contact Factory	Contact Factory	Contact Factory	Contact Factory
Inductance Saturation Current		L _{isat}	Arms	86	124	149	100	149	171	299	101	149	236	210	264	299
Maximum Demagnetization Current		Midpeak	Arms	Contact Factory	Contact Factory	Contact Factory	Contact Factory	Contact Factory	Contact Factory	Contact Factory	Contact Factory	Contact Factory	Contact Factory	Contact Factory	Contact Factory	Contact Factory
Inertia (includes Resolver feedback) ③	±10%	J _m	kg-cm ²	25.9			46.8			67.7			88.6			
			lb-in-s ²	2.29E-02			4.14E-02			5.99E-02			7.84E-02			
Optional Brake Inertia (additional)	±10%	J _m	kg-cm ²	12.3			12.3			12.3			12.3			
			lb-in-s ²	1.09E-02			1.09E-02			1.09E-02			1.09E-02			
Weight without brake ④		W	kg	16.8			22.9			29.0			35.2			
			lb	37.0			50.5			64.0			77.5			
Static Friction ①⑤		T _f	Nm	0.135			0.158			0.236			0.315			
			lb-in	1.19			1.40			2.09			2.79			
Viscous Damping ①		K _{dv}	Nm/k _r rpm	0.0865			0.173			0.260			0.346			
			lb-in/k _r rpm	0.766			1.53			2.30			3.06			
Thermal Time Constant		TCT	minutes	38			43			49			56			
Coil Thermal Time Constant		MCT _{f0}		Contact Factory			Contact Factory			Contact Factory			Contact Factory			
Thermal Resistance ①		R _{thw-a}	K/W	0.360			0.307			0.264			0.237			
Pole Pairs		PP		4			4			4			4			
Heat Sink Size				18"x18"x1/2" Aluminum Plate			18"x18"x1/2" Aluminum Plate			18"x18"x1/2" Aluminum Plate			18"x18"x1/2" Aluminum Plate			

Notes:

① Motor winding temperature rise, ΔT = 100 °C, at 40 °C ambient.

② Measured at 25 °C.

③ Add parking brake if applicable for total inertia.

④ Brake motor adds 9.1 kg [20 lbs]

⑤ Shaft seal increases Static Friction by 0.25 Nm [2.2 lb-in]

⑥ This value is calculated from the Torque Constant and Resistance. Refer to those values and notes ① & ② for additional details.

* If compliance to UL 508 is required, then any winding above 16 Arms/Phase continuous current rating, requires M40 "E", "H" or "J" connector. Please contact Kollmorgen Customer Service for co-engineered solution evaluation.

AKM2G-7x Series Motor Specifications

AKM2G-7x De-rate Curves

Refer to the [Servo Motor Performance Curve Overview](#) section for additional details about Derate.

Example:

For an AKM2G-71 motor with an SFD feedback with shaft seal and no brake operating at 3000 RPM there is a 24.8% De-rate. Multiply the motor torque value (T_{CS}) by .752 for the rated torque at 3000 RPM. For ease of interpretation of the graph using a De-rate that is a rounded approximation is acceptable. For exact values refer to Kollmorgen's Motioneering Application Sizing programs, or the Kollmorgen website Performance Curve Generator.

Note: De-rates are referenced to the Continuous Torque ΔT wdg. = 100 °C.

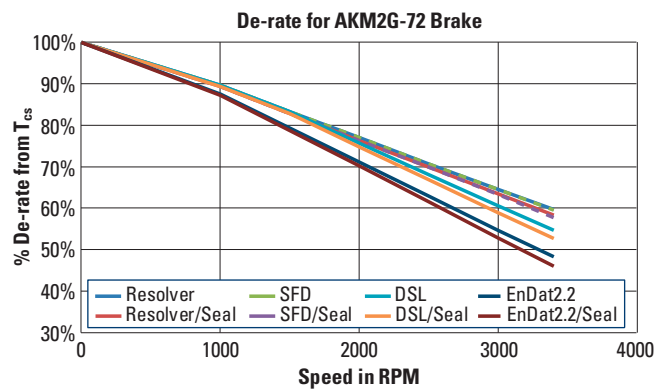
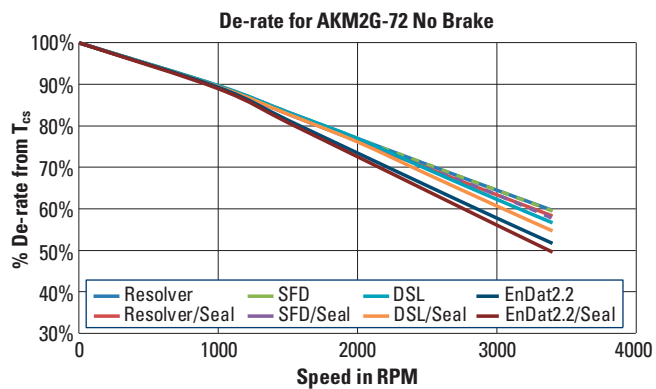
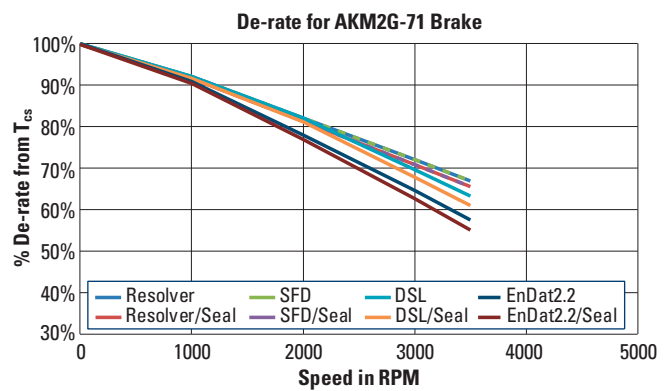
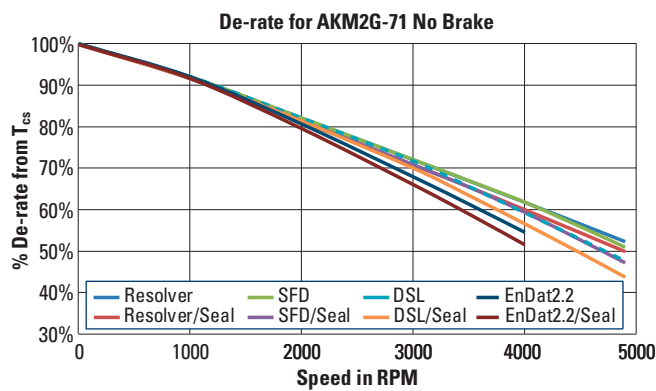

Continued on following page

⚠ IMPORTANT

Derate information for general estimation only. Use the on-line Performance Curve Generator located at <https://www.kollmorgen.com/en-us/service-and-support/technical/performance-curve-generator> for the most accurate information for your motor, or refer to Kollmorgen's Motioneering Online Tool located at <https://www.kollmorgen.com/en-us/service-and-support/technical/motioneering-online>

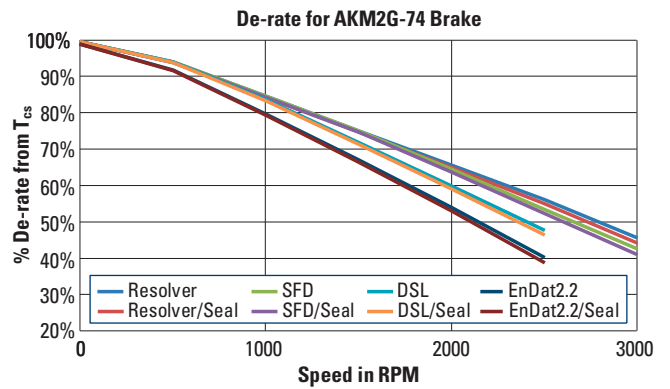
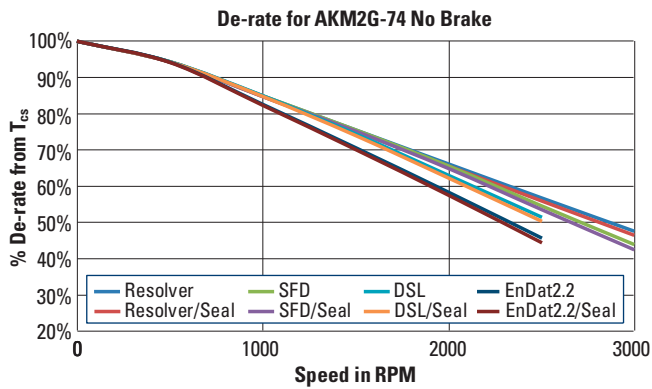
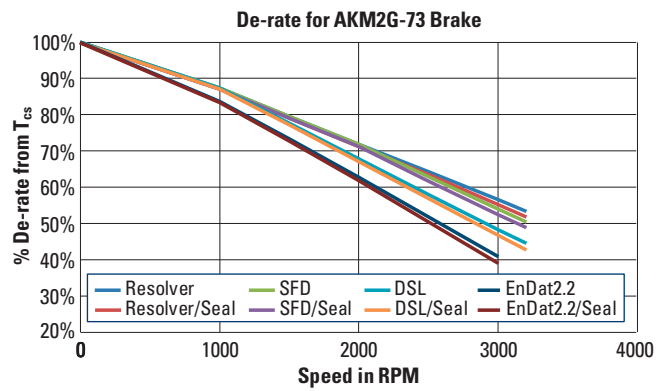
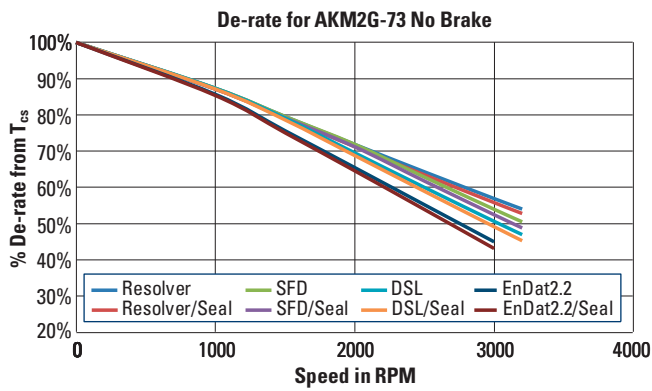

AKM2G-7x Series Motor Specifications

AKM2G-7x (L, N Windings) Dimensional Drawings and Data

AKM2G-7x A-, D- Single Connector Frame

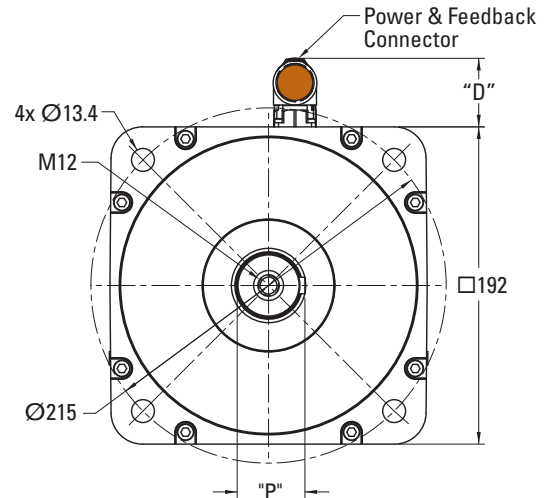
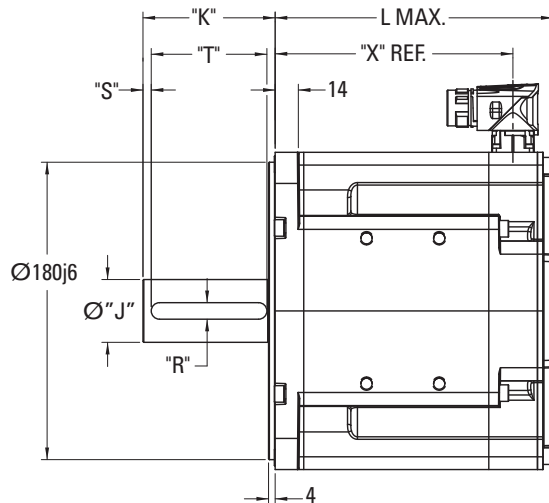

AKM2G-7x A-, C- Dual Connector Frame

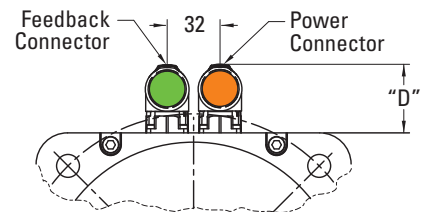

AKM2G-7x Mounting Flange-Shaft Dimensional Data

Mounting Flange-Shaft	Shaft Diameter	Shaft Length	Shaft Dia. w/ Key	Key Width	-	Key Length
	"J"	"K"	"P"	"R"	"S"	"T"
AC	38k6	80	41	10	5	70
AN	38k6	80	-	-	-	-
GC	32k6	58	35	10	4	45
GN	32k6	58	-	-	-	-

All dimensions in mm

AKM2G-7x Connector Height

Connector Feedback	"D"
SFD3 (CA) & SFD-M (CB)	42.8
HDSL (GU) & EnDat 2.2/22 (LD)	44.1

Note: Product designed in metric.

Related Topics:

[Feedback Options and Specifications](#)
[Connector Options and Pinouts](#)

AKM2G-7x "X" and "L" Dimensions - L, N Windings

Connector	No Brake (N)			
	"L" MAX			"X" REF
Feedback Option	A-, C-, D-	A-, C-, D-	A-, C-	A-, C-, D-
AKM2G-71	Cx, 2-, R-	GU, LD	Ax, Dx	All
AKM2G-71	169.10	181.10	189.20	143.90
AKM2G-72	203.05	215.05	233.15	177.85
AKM2G-73	237.00	249.00	257.10	211.80
AKM2G-74	270.95	282.95	291.05	245.75
+ Brake ("2" option)	All AKM2G-7x: Add +77.45 mm to both "L" and "X" dimensions			

All dimensions in mm

AKM2G-7x (P, Q, R Windings) Dimensional Drawings and Data

AKM2G-7x E-, J- Single Connector Frame

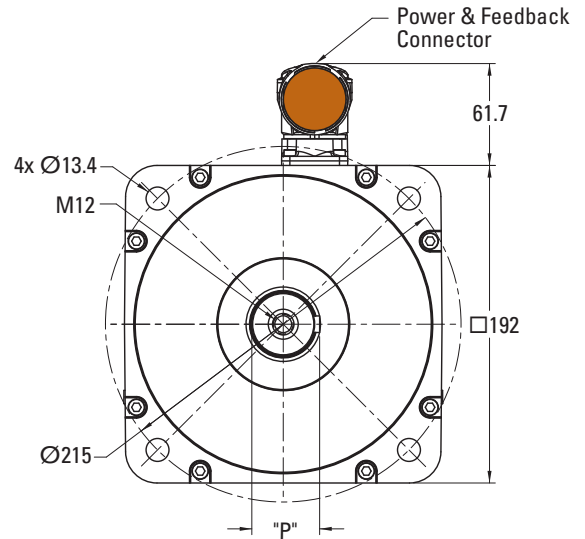
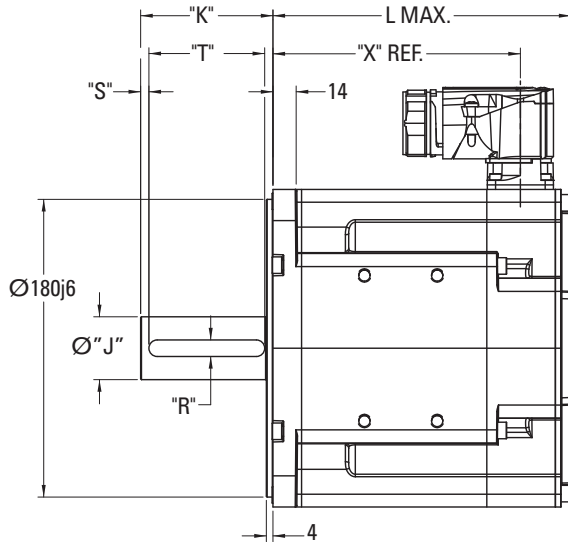

AKM2G-7x H- Dual Connector Frame

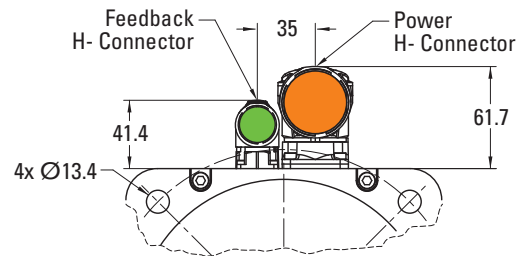

AKM2G-7x Mounting Flange-Shaft Dimensional Data

Mounting Flange-Shaft	Shaft Diameter	Shaft Length	Shaft Dia. w/ Key	Key Width	-	Key Length
	"J"	"K"	"P"	"R"	"S"	"T"
AC	38k6	80	41	10	5	70
AN	38k6	80	-	-	-	-
GC	32k6	58	35	10	4	45
GN	32k6	58	-	-	-	-

All dimensions in mm

Note: Product designed in metric.

Related Topics:

[Feedback Options and Specifications](#)
[Connector Options and Pinouts](#)

AKM2G-7x "X" and "L" Dimensions - P, Q, R Windings

Connector	No Brake (N)		
	"L" MAX		"X" REF
	E-, J-, H-	H-	E-, J-, H-
Feedback Option	Cx, GU, LD 2-, R-	Ax, Dx	All
AKM2G-71	168.10	189.20	189.20
AKM2G-72	190.15	211.25	223.15
AKM2G-73	212.20	233.30	257.10
AKM2G-74	234.25	255.35	291.05
+ Brake ("2" option)	All AKM2G-7x: Add +77.45 mm to both "L" and "X" dimensions		

All dimensions in mm

AKM2G Brake Option

Failsafe, Holding Brake

The holding brake is designed to provide static holding torque to the motor shaft with the brake coil de-energized. The brake must first be released (coil energized) prior to commanding motor rotation as determined by its drop-out time. The brake is intended for holding or “parking” of a stationary motor. It is not intended for dynamic braking. There should be absolutely no motion of the rotor when power is removed from the brake coil.

AKM2G Motor Brake Specifications

Motor Family	Minimum Static Torque @120 °C		Weight Adder		Power Consumption Nominal	Current ¹ @24 V, 20 °C	Inertia Adder		Closing Time (engage)	Opening Time (release)	Backlash ²	
											Maximum	Typical
	Nm	lb-in	Kg	lb	Watts ±7%	ADC	kg-cm ²	lb-in-sec ²	msec	msec	deg.	deg.
AKM2G-2	2	17.7	0.45	1.0	11.4	0.47	0.04	3.5E-05	25	40	1	0.32
AKM2G-3	3.3	29.205	0.72	1.6	12.6	0.53	0.12	1.1E-04	35	55	1	0.6
AKM2G-4	7	62.0	1.36	3.0	14.7	0.61	0.36	3.2E-04	50	85	1	0.55
AKM2G-5	16	141.6	2.6	5.7	20.8	0.87	1.2	1.1E-03	80	135	1	0.6
AKM2G-6	32	283.2	4.5	10.0	29.5	1.23	3.6	3.2E-03	90	150	1	0.25
AKM2G-7	80	708	9.1	20.1	37.6	1.57	12.3	1.1E-02	120	300	1	0.2

Contamination of the motor internal compartment by oil or other foreign materials will result in failure of the brake. Check the suitability of motor sealing for the working environment.

Note 1: Operating Voltage: 24 VDC ± 10%.

Note 2: Maximum backlash is calculated using worst-case tolerancing, and typical backlash is calculated using statistical tolerancing.

AKM2G Feedback Options

AKM2G Servo Motor Feedback Summary with AKD Family Servo Drives

Feedback Unit Options

Functional Safety Capable

Code ³	Description	AKM2G ⁴	Connector	Single-turn or Multi-turn	Feedback Type/Size	Feedback Resolution				Accuracy ^{1,2} (arc-sec)
						Device Resolution (Sin/Cos per Rev., Bits or Lines/Rev.)	AKD Internal Resolution	AKD2G Internal Resolution	# of Absolute revs.	
2-	Commutating Encoder	2 non-LV	Y	Single-turn	15	2048 Lines	8,192	8,192	None	±218.2"
		3-4	Ad, C		21					
		5-7 ≤ 20A								
AA	BiSS B Optical Sine Encoder	2 non-LV	Y	Single-turn	AD34	2048 Sin/Cos	27-Bits	32-Bits	1	±36"
3, 4		Ad, C	AD58							
5-7 ≤ 20A			Multi-turn		AD34				4096	
3, 4	Ad, C	AD58								
5-7 ≤ 20A										
CA	SFD3 Smart Feedback Device Gen. 3	2-4	AH, D	Single-turn	15	24-Bits	24-Bits	24-Bits	1	±585"
		5-7 ≤ 20A	AH, D		21					
		7 > 20A	E		21					
CB	SFD-M Smart Feedback Device Multi-turn	2-7 ≤ 20A	AH, D	Multi-turn	15	24-Bits	24-Bits	24-Bits	65,536	±60"
		7 > 20A	E							
GU	HIPERFACE DSL Capacitive	2-7 ≤ 20A	D	Multi-turn	EEM37-2*	17-Bits	17-Bits	17-Bits	1	±240"
		7 > 20A	J							
DA	EnDat 2.2/01 Optical	2 non-LV	Y	Single-turn	ECN1113	512 Sin/Cos	25-Bits	32-Bits	1	±60"
		3, 4	Ad, C		ECN1313	2048 Sin/Cos	27-Bits			±20"
DB	EnDat 2.2/01 Optical	2 non-LV		Y	Multi-turn	EQN1125	512 Sin/Cos	25-Bits	32-Bits	4096
		3, 4	Ad, C	EQN1325		2048 Sin/Cos	27-Bits	±20"		
LD	EnDat 2.2/22 Inductive	2-4		D	Multi-turn	EQI 1131**	19-Bits	19-Bits	19-Bits	4096
		5-7 ≤ 20A	H	EQI 1331**		±65"				
7 > 20A										
	R-	Resolver Inductive	2 non-LV	Y	Single-turn	15	1 pole pair (16-Bits)	16-Bits	16-Bits	1
3-4			Ad, C	21						
5-7 ≤ 20A										
7 > 20A			H							

AH = M23 Hybrid power/SFD3/SFD-M connector pinned for use with legacy AKM performance cables - not compatible with AKM2G cables.

Ad = M23 Dual connectors with power connector pinned for use with legacy AKM performance cables - not compatible with AKM2G cables.

- AKD drives have a resolver measurement accuracy of ±45", for a drive w/ motor accuracy of ±585" and RMS Noise of ±9.9" Accuracy & RMS Noise data when used with other drives may be different.
- Accuracy refers to overall system accuracy once installed in the motor. Noise refers to the RMS position noise when at stand-still.
- All feedback options, except R- and 2-, have Motor ID support with embedded electronic motor nameplate data included for easy plug-and-play commissioning with Kollmorgen servo drives.
- AKM2G-LV Size 2 models are only available in single-connector configurations.

With AKD drives, all received positions are interpolated to a 32-bit resolution per revolution. When using a drive other than AKD consult the drive manufacturer for this information.

*SICK HIPERFACE DSL model EEM37-2. Please visit <https://www.sick.com> to download the latest safety data sheet.

**HEIDENHAIN models EQI1131 & EQI1331. Please visit <https://www.heidenhain.com> to download the latest safety data sheets.

AKM2G Feedback Specifications

Absolute Digital Encoder Options

Kollmorgen Smart Feedback Device, Multi-turn (SFD-M) (CB)

The SFD-M Feedback uses a single motor cable, requiring just one cable between the drive and motor.

The feedback has both power and communication on a single wire pair, reducing overall wiring costs. SFD-M offers 24-bit absolute single-turn resolution, batteryless 16-bit (65,536) multi-turn absolute revolutions and an absolute angular accuracy of +/- 1 arc-min.

In addition, the device includes onboard memory for an electronic motor datasheet which enables device auto-recognition for faster setup and commissioning when paired with any Kollmorgen Essentials, AKD, or AKD2G drive.

Angle Measurement:

Single-Turn Resolution: $2^{24} = 16,777,216$ counts per rev

Multi-Turn Absolute Range: $2^{16} = 65,536$ absolute revolutions* (batteryless)

Accuracy: < +/- 1 arc-min typical 25 °C
< +/- 3 arc-min worst case

Electrical Noise: < 2^{-22} Rev rms at full bandwidth

Bandwidth: > 2 kHz at -3 dB

> 1 kHz at -45° phase lag

Max Continuous Speed: 10,000 RPM

Velocity Ripple: < 1% p-p (typical)

Velocity Noise: < 0.3 RPM rms at full bandwidth

Power Supply:

Input Voltage: 7 V - 12 V accepted (at motor terminals)

Input current maximum: 140 mA DC

Digital Communications:

Baud rate: 2.5 MBaud

Signaling: RS-485 differential using differential Manchester encoding

Update period: New position sample every 51.2 μs

Error detection: 5-bit CRC and running parity check

Environmental:

Feedback Operating Temperature: -40 to 120 °C

Humidity: 10% to 90% non-condensing

Vibration Resistance: 30g (294 m/s²) @ 55-2000 Hz (EN60068-2-6)

Shock Resistance: 100g (981 m/s²) @ 6 ms (EN60068-2-27)

* When paired with AKD, this is limited to 4096 absolute revolutions (12-bits)

Kollmorgen Smart Feedback Device, Gen 3 (SFD3) (CA)

Kollmorgen's proprietary SFD3 Feedback uses a single motor cable, requiring just one cable between the drive and motor. The feedback has both power and communication on a single wire pair, reducing overall wiring costs. In addition, the device includes onboard memory for an electronic motor datasheet.

Angle Measurement:

Resolution: 24 bits, $2^{24} = 16,777,216$ counts per rev

Accuracy: < ± 0.75 arc-min electrical + sensor error

Size 15 sensor ± 9.75 arc-min net (AKM2G 2,3,4)

Size 21 sensor ± 9.75 arc-min net (AKM2G 5,6,7)

Electrical noise: < 2^{-17} Rev rms at full bandwidth

Bandwidth: > 2000 Hz at -3 dB

> 1000 Hz at -45° phase lag

Max tracking rate: > 50,000 RPM

Velocity ripple: < 0.2% p-p electronics only

Size 15 sensor < 1.5% p-p net (AKM2G 2,3,4)

Size 21 sensor < 1.5% p-p net (AKM2G 5,6,7)

Velocity noise: < 4 RPM rms at full bandwidth

Environmental:

Operating ambient: -20 to 120 °C

Humidity: 10% to 90% non-condensing

Storage temperature: -40 to 135 °C

Digital Communications:

Baud rate: 2.5 MBaud

Signaling: RS-485 differential using differential Manchester encoding

Update period: New position sample every 51.28 μs

Error detection: 5-bit CRC and running parity check

Power Supply:

Supply at Drive: 7 to 12 V

Supply at SFD in motor: 7 to 12 V

Nominal Supply Current: 65 mA at 10 V

Worst Case Supply: 110 mA at 10 V

Cable Resistance: Com+, Com- net < 10 Ohm net

Absolute Digital Encoder Options

HIPERFACE DSL Capacitive (GU)

Type		Multi-Turn "GU"
Frame Size		AKM2G2-7 ≤ 20 A
Number of Absolute Ascertainable Revolutions		4096
Supply Voltage Range	VDC	7 to 12
Current Consumption	mA MAX.	150
Operating Temperature	°C MIN/MAX	-40/115
Inertia	kg-cm ²	0.001
Output Interface		SICK HIPERFACE DSL
Vibration Resistance – EN 60068-2-6	g [m/s ²]	50 g [490 m/s ²] – 10 to 2000 Hz
Shock Resistance – EN 60068-2-27	g [m/s ²]	≤100 g [981 m/s ²] – 6 ms
Manufacturer Product Type		■ EEM37-2KF0A017A*017A*

■ Functional Safety Capable *SICK HIPERFACE DSL model EEM37-2KF0A017A. Please visit <https://www.sick.com> to download the latest safety data sheet.

Absolute Digital Encoder Options

EnDat Inductive (LD)

Type		Multi-Turn "LD"	
Frame Size		AKM2G 2, 3, 4	AKM2G 5, 6, 7
Revolutions		4096	4096
Input Voltage	VDC	3.6 to 14	3.6 to 14
Current Consumption	mA Typical	5 V: 115 (without load)	5 V: 115 (without load)
Operating Temperature	°C MIN/MAX	-40/115	-40/115
Inertia	kg-cm ²	0.0030	0.0026
Output Interface		HEIDENHAIN EnDat 2.2/22*	
Vibration Resistance – EN 60068-2-6	g [m/s ²]	Stator ≤41 g [400 m/s ²] – Rotor ≤61 g [600 m/s ²] – 55 to 2000 Hz	
Shock Resistance – EN 60068-2-27	g [m/s ²]	≤100 g [981 m/s ²] – 6 ms	
Manufacturer Product Type		■ EQI 1131*	■ EQI 1331*

■ Functional Safety Capable *HEIDENHAIN models EQI1131 & EQI1331. Please visit <https://www.heidenhain.com> to download the latest safety data sheets.

Encoder Alignment: With positive DC current into phase W and out of phase V (U floats) the encoder is aligned to ±3 electrical degrees.

Absolute Sine Encoder Options

EnDat Optical (DA, DB)

Type		Single-Turn "DA"		Multi-Turn "DB"	
Frame Size		AKM2G 2-4	AKM2G 5-7	AKM2G 2-4	AKM2G 5-7
Cycles per Revolution (# of abs. revs.)	-	512 (1)	2048 (1)	512 (4096)	2048 (4096)
Input Voltage	VDC	3.6 to 14	3.6 to 14	3.6 to 14	3.6 to 14
Current Consumption	mA Typical	85 (no load)	85 (no load)	105 (no load)	105 (no load)
Feedback Operating Temperature	°C MIN./MAX.	-40/115	-40/115	-40/115	-40/115
Inertia	kg-cm ²	0.04	0.026	0.04	0.026
Output Interface		HEIDENHAIN EnDat 2.2/01			
Manufacturer Product Type		ECN1113	ECN1313	EQN1125	EQN1325

Encoder Alignment: With positive DC current into phase W and out of phase V (U floats) the encoder is aligned to ±1 electrical degree.

AKM2G Feedback Specifications

Absolute Sine Encoder Options

BiSS Optical (AA, AB)

Type		Single-Turn "AA"		Multi-Turn "AB"	
Frame Size		AKM2G 2-4	AKM2G 5-7	AKM2G 2-4	AKM2G 5-7
Cycles per Revolution (# of abs. revs.)	-	2048 (1)	2048 (1)	2048 (4096)	2048 (4096)
Input Voltage	Vdc (tolerance)	5 (-5%/+10%)	5 (\pm 10%)	5 (-5%/+10%)	5 (\pm 10%)
Current Consumption	mA Typical	100 (without load)	100 (without load)	150 (without load)	100 (without load)
Feedback Operating Temperature	°C MIN./MAX.	-15/120	-15/120	-15/120	-15/120
Inertia	kg-cm ²	0.025	0.038	0.025	0.038
Output Interface	Hengstler BiSS B				
Manufacturer Product Type		AD34	AD58	AD34	AD58

Encoder Alignment: With positive DC current into phase W and out of phase V (U floats) the encoder is aligned to ± 1 electrical degree.

Resolver Options

Resolver (R-)

Type		R- 1 Speed	
Frame Size		AKM2G 2, 3, 4	AKM2G 5, 6, 7
Input Voltage	V _{RMS}	7.0	7.0
	k Hz	10	10
Input Current Max.	mA	50	50
Transformation Ratio	N/A	0.5 \pm 10%	0.5 \pm 10%
Null Voltage	mV _{RMS}	30	30
Max. Error (pk-pk)	MINS.	18	18
Phase Shift	Degrees	0	0
Operating Temperature	°C	-55 to 155	-55 to 155
Rotor Inertia Max.	kg-cm ²	0.046	0.497
Vibration and Shock Resistance	High Vibration and Shock Resistance Please contact Kollmorgen Customer Support		

Resolver Alignment

With positive DC current into phase W and out of phase V (U floats), the resolver is aligned. ie. Voltage S1-S3 set to null and voltage S2-S4 max in phase with reference (R1-R2).

Resolver Winding Configuration

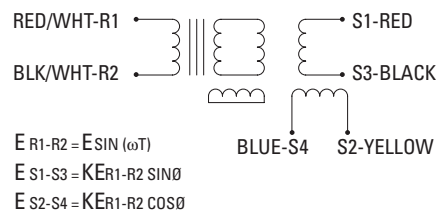

Commutating Encoder Option

Commutating Encoder (2-)

Parameter		2-
Frame Size		AKM2G 2-7
Input Voltage	Vdc ±10%	5
Output Data	-	26LS31 Diff. Line Driver. Sink/Source 40mA Max
Line Count per revolution	-	2,048
Frequency Response	KHz	200
Max. Speed	RPM	8,000
Min. Edge Separation of Incremental Channel	°e MIN.	45
Index to U Comm Channel	-	±1°m Index Center to U Falling Edge
Index Pulse Width	-	Gated With B Low
Incremental Channel Accuracy	-	±1 Arc Min. Max. Edge to Edge
Max. Acceleration	Rad/s ²	100,000
Feedback Operating Temperature	°C	0 to 120
Storage Temperature	°C	-40 to 120
Vibration Resistance - EN 60068-2-6	g [m/s ²]	10 g [98 m/s ²] - 58 to 500 Hz
Shock Resistance - EN 60068-2-27	g [m/s ²]	80 g [785 m/s ²] - 11 ms

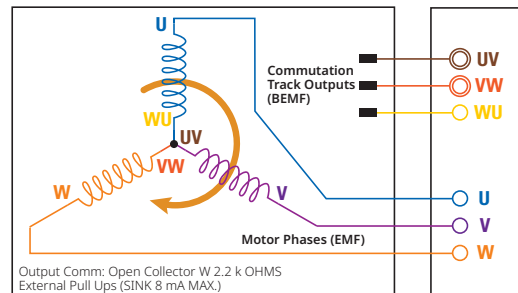
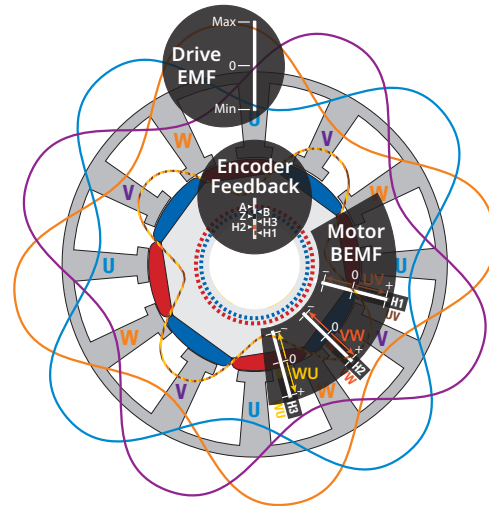
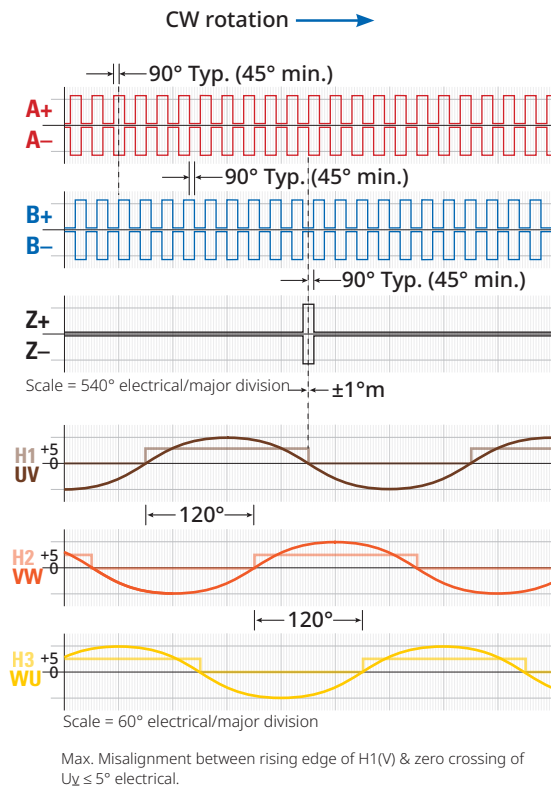

AKM2G Motor Connector Options

Connector Options

Model Designation	Connection	Compatible AKM2Gx	Position of connection
A* (Hybrid)	1 SpeedTec M23 (AKM cable pinned)	AKM2G2 - AKM2G7 ≤ 20 Amps	Angular, rotatable, motor mounted
A (Dual)	2 SpeedTec M23 (AKM cable pinned)	AKM2G3 - AKM2G7 ≤ 20 Amps	Angular, rotatable, motor mounted
C	2 SpeedTec M23	AKM2G3 - AKM2G7 ≤ 20 Amps	Angular, rotatable, motor mounted
D*	1 htec M23	AKM2G2 - AKM2G7 ≤ 20 Amps	Angular, rotatable, motor mounted
E*	1 M40 (AKM cable pinned)	AKM2G7 > 20 Amps	Angular, rotatable, motor mounted
H	1 M40 Power, 1 M23 Feedback	AKM2G7 > 20 Amps	Angular, rotatable, motor mounted
J*	1 htec Connector M40	AKM2G7 > 20 Amps	Angular, rotatable, motor mounted
Y	1 ytec Connector	AKM2G2 (non LV)	Rotatable, motor mounted

* Hybrid connectors valid for SFD3, SFD-M, HDSL, and EnDat 2.2 Feedback only.

Connector Description

Connector	Usage	Contacts - Pins Power/Signal	Max. Current [A] Power/Signal	Max. Cross Section [mm ²] Power/Signal	Protection Class
M23 SpeedTec right angle connectors (Size 1)	Power & Brake	4 / 5	20 / 10	4 / 1.5	IP65
	Comcoder	- / 15	- / 10	4 / 1.5	IP65
	Resolver	- / 12	- / 10	- / 0.5	IP65
	HDSL	5 / 2 / 2	20 / 10	4 / 1.5	IP65
	SFD3/SFD-M	4 / 5	20 / 10	4 / 1.5	IP65
	EnDat 2.2	5 / 4 / 6	20 / 10	4 / 1.5	IP65
	EnDat 2.1 / BiSS B	- / 12	- / 10	4 / 1.5	IP65
M40 (Size 1.5)	Power & Brake	4 / 5	48 / 30	16 / 4	IP65
	SFD3	4 / 5	48 / 30	16 / 4	IP65
	HDSL	5 / 4 / 2	48 / 30	16 / 4	IP65
ytec	Power & Brake	4 / 5	7 / 3.6	1.5 / 0.75	IP65
	Resolver	- / 12	- / 5	- / 0.75	IP65
	EnDat 2.1 / BiSS B	- / 12	- / 5	- / 0.75	IP65

Feedback and Connector Availability

AKM2G-2				AKM2G- 3-6				AKM2G-7 (L, N Windings)				AKM2G-7 (P, Q, R Windings)							
Connector Code	A	D	Y	Connector Code	A	C	D	Connector Code	A	C	D	Connector Code	A	E	H	J			
Feedback Code	2-		•	Feedback Code	2-	•	•	Feedback Code	2-	•	•	Feedback Code	2-	•		•			
	Ax		•		Ax	•	•		Ax	•	•		Ax	•		•			
	Cx	•	•		Cx	•			•	Cx	•			•	Cx		•		
	GU		•		GU				•	GU				•	GU				•
	Dx				•	Dx	•		•		Dx		•	•		Dx	•		•
	LD		•			LD				•	LD				•	LD			•
	R-				•	R-	•		•		R-		•	•		R-	•		•

- = Hybrid (power + feedback) single connector
- = Dual power and feedback connectors

AKM2G Motor Connector Pinouts

Dual Cable Options – Power & Feedback

A-, C- Dual Connector Pinouts – AKM2G 3-7 ≤ 20 Amps Continuous

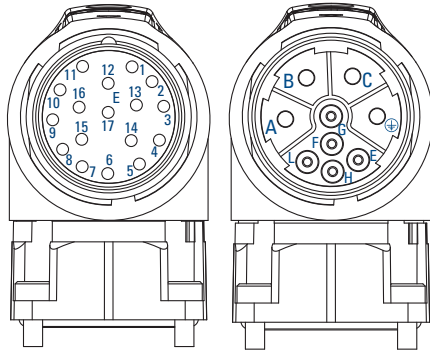

A-, C- Dual Connectors
C- Power Pinout Shown

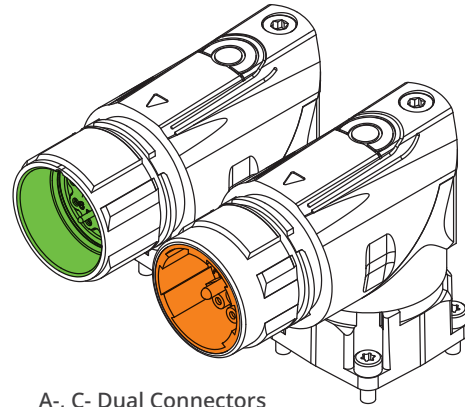

A-, C- Dual Connectors

A-, C- Feedback Connector Pinouts

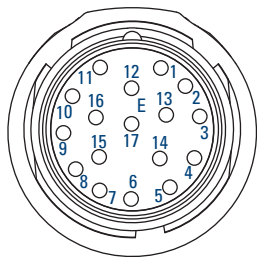

A-, C- 17-pin Connector

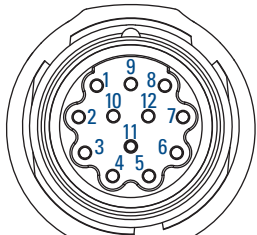

A-, C- 12-pin Connector

Commutating Encoder Feedback

Pin	Function
1	B
2	B
3	A
4	A̅
5	Z
6	Z̅
7	GND
8	Thermal Sensor +
9	Thermal Sensor -
10	Vcc
11	N/C
12	N/C
13	N/C
14	N/C
15	U
16	V
17	W

EnDat/BiSS

Pin	Function
1	B -
2	PE
3	A -
4	Vcc 5 Vdc
5	DATA
6	N/C
7	Thermal Sensor +
8	Clock
9	B +
10	Un Sense (Common)
11	A +
12	Up Sense (Vcc)
13	DATA
14	Thermal Sensor -
15	Clock
16	N/C
17	N/C

Resolver Connector

Pin	Function
1	N/C
2	Thermal Sensor +
3	S4, COS-
4	S3, SIN-
5	R2, REF-
6	Thermal Sensor -
7	S2, COS+
8	S1, SIN+
9	R1, REF+
10	N/C
11	N/C
12	N/C

Shield is Not Connected at Motor End.
On motor mounted connectors, the thermal sensor lead colors are (+) Blue, (-) Black.

A- Power Connector Pinout

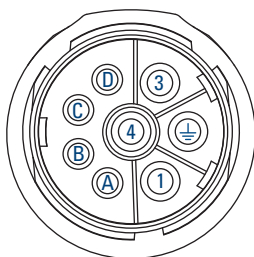

A- Connector

Power Connector

Pin	Function
1	U
2	PE
3	W
4	V
A	Brake +
B	Brake -
C	N/C
D	N/C

Note: Only for use with legacy AKM cables - not compatible with 2G Cables

C- Power Connector Pinout

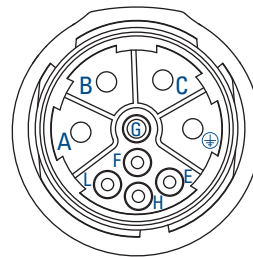

C- Connector

Power Connector

Pin	Function
A	U
⊕	PE
C	W
B	V
F	Brake +
G	Brake -
E	N/C
H	N/C
L	N/C

Shield Connected to Motor Ground Internal to Motor

AKM2G Motor Connector Pinouts

Dual Cable Options – Power & Feedback

H- Dual Connector Pinout – AKM2G7 > 20 Amps Continuous resolver motors

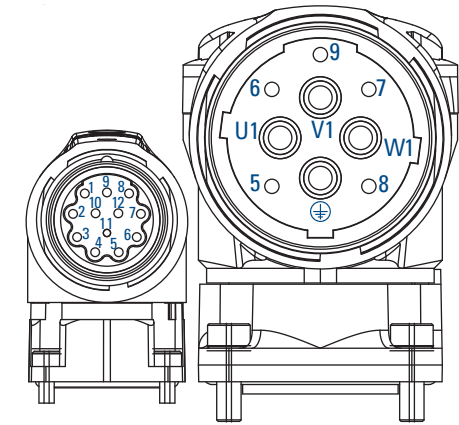

Resolver Connector Power Connector

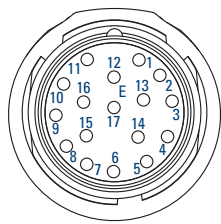

EnDat Connector

EnDat

Pin	Function
1	B -
2	PE
3	A -
4	Vcc 5 Vdc
5	DATA
6	N/C
7	Thermal Sensor +
8	Clock
9	B +
10	Un Sense (Common)
11	A +
12	Up Sense (Vcc)
13	DATA
14	Thermal Sensor -
15	Clock
16	N/C
17	N/C

Resolver

Pin	Function
1	N/C
2	Thermal Sensor +
3	S4, COS-
4	S3, SIN-
5	R2, REF-
6	Thermal Sensor -
7	S2, COS+
8	S1, SIN+
9	R1, REF+
10	N/C
11	N/C
12	N/C

Shield is Not Connected at Motor End
On motor mounted connectors, the thermal sensor lead colors are (+) Blue, (-) Black.

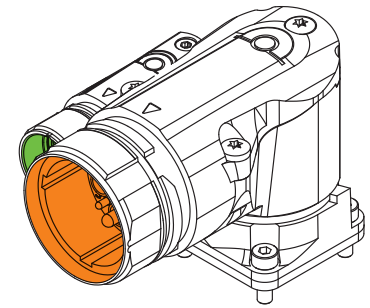

H- Dual Connectors

Power Connector

Pin	Function
U1	U
V1	V
W1	W
⊕	PE
5	Brake +
6	N/C
7	N/C
8	Brake -
9	N/C

Shield Connected to Motor
Ground Internal to Motor

Dual Cable Options – Power & Feedback

ytec® - Connector Pinout – AKM2G2 only

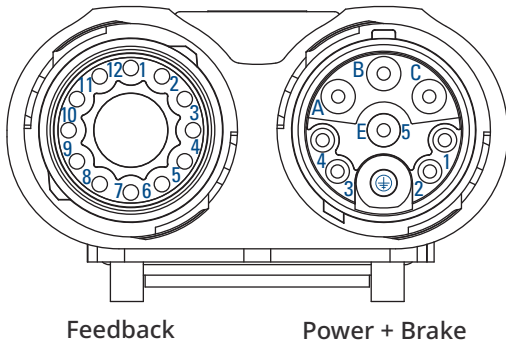

Power Connector

Pin	Function
1	BR+
2	BR-
3	N/C
4	N/C
5	N/C
A	U
B	W
C	V
E	N/C
G	PE

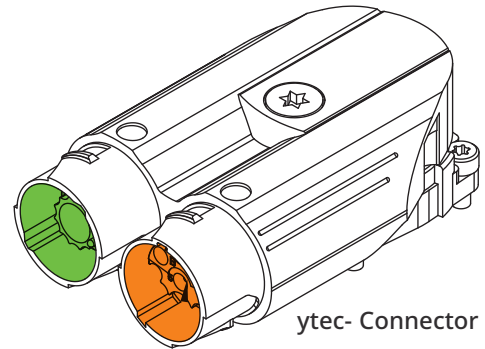

ytec- Connector

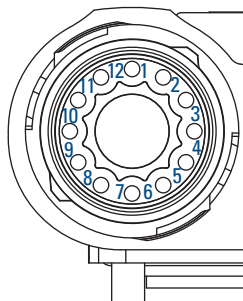

Resolver Connector

ytec-Resolver Connector

Connector Part Number:
EEDA-101-NN-00-00-0001-000

Resolver

Pin	Function
1	N/C
2	TH+
3	S4, cos-
4	S3, sin-
5	R2, ref-
6	TH-
7	S2, cos+
8	S1, sin+
9	R1, ref+
10	N/C
11	N/C
12	N/C

ytec-EnDat/BiSS Connector

Connector Part Number:
EEDA-103-NN-00-00-0001-000

EnDat/BiSS

Pin	Function
1	B-
2	GND
3	A-
4	Vcc
5	DATA+
6	N/C
7	Thermal Sensor +
8	Clock
9	B+
10	Un Sense (Common)
11	A+
12	Up Sense (Vcc)
A	DATA-
B	Thermal Sensor -
C	Clock-

Commutating Encoder

Pin	Function
1	B+
2	B-
3	A+
4	A-
5	Z
6	Z-
7	GND
8	Thermal Sensor +
9	Thermal Sensor -
10	Vcc
11	N/C
12	N/C
A	U
B	V
C	W

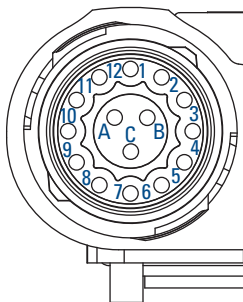

EnDat/BiSS, Comcoder

AKM2G Motor Connector Pinouts

Single Cable Options – Power & Feedback

D- Connector Pinouts – Hybrid power and feedback for SFD3, SFD-M, DSL, and EnDat for all AKM2G < 20 Amps Continuous

D- Hybrid Power + SFD3/SFD-M Connector Option

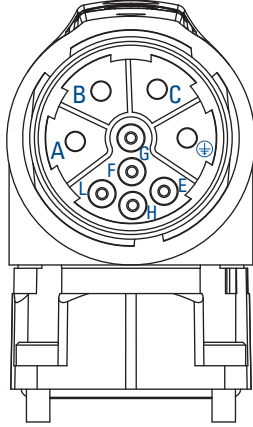

Power + SFD3/SFD-M

Pin	Function
A	Phase U
B	Phase V
C	Phase W
⊕	PE
E	N/C
F	Brake +
G	Brake -
H	SFD +
L	SFD -

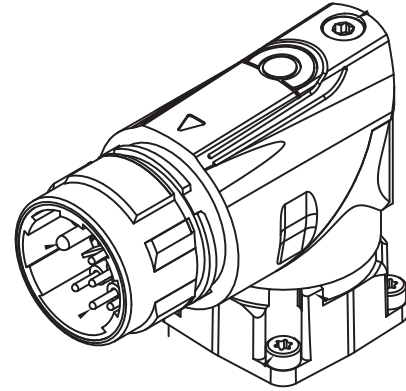

D- Hybrid Power + HIPERFACE DSL Connector Option

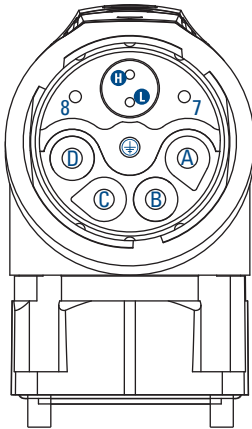

Power + HDSL

Pin	Function
A	Phase U
B	Phase V
C	Phase W
D	N/C
⊕	PE
8	Brake +
7	Brake -
L	HDSL -
H	HDSL +

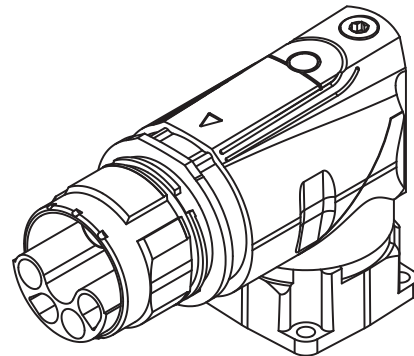

D- Hybrid Power + EnDat Connector Option

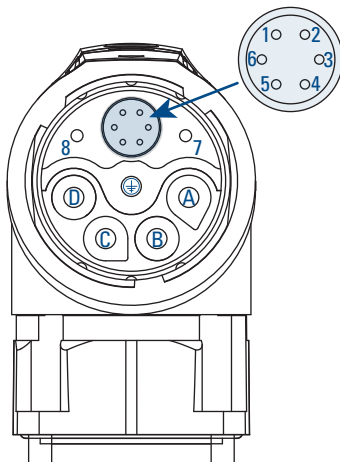

Power + EnDat

Pin	Function
A	Phase U
B	Phase V
C	Phase W
D	N/C
⊕	PE
8	Brake +
7	Brake -
1	Up
2	0 V
3	Data +
4	Data -
5	Clock +
6	Clock -

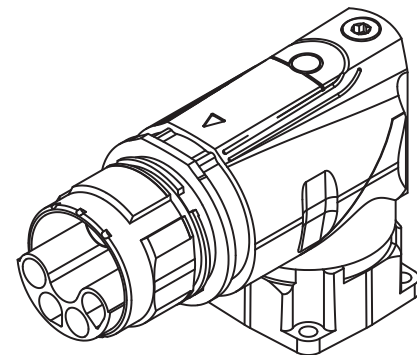

Single Cable Options – Power & Feedback

A- Connector Pinout – AKM2G 2-7 ≤ 20 Amps Continuous SFD3/SFD-M motors

Note: Only for use with legacy AKM cables - not compatible with 2G Cables

A- Hybrid Power + SFD3/SFD-M Connector Option

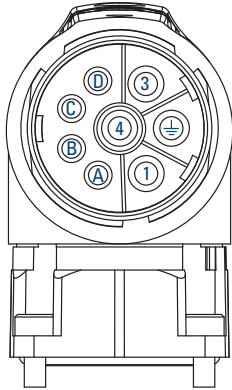

Power + SFD3/SFD-M

Pin	Function
1	U
⊕	PE
3	W
4	V
A	Brake +
B	Brake -
C	SFD3/-M +
D	SFD3/-M -

Connector Part Number:
BEDC-110-NN-00-00-1216-000

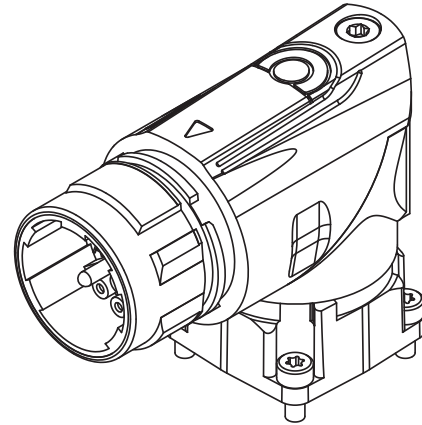

E- Connector Pinout – AKM2G7 > 20 Amps Continuous SFD3 and SFD-M motors

Note: Only for use with legacy AKM cables - not compatible with 2G Cables

E- Hybrid Power + SFD3/SFD-M Connector Option

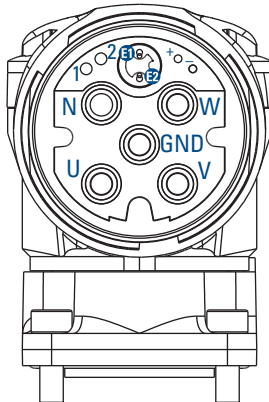

Power + SFD3/SFD-M

Pin	Function
U	Phase U
V	Phase V
W	Phase W
N	N/C
GND	PE
1	Brake +
2	Brake -
+	N/C
-	N/C
E2	SFD3/SFD-M -
E1	SFD3/SFD-M +

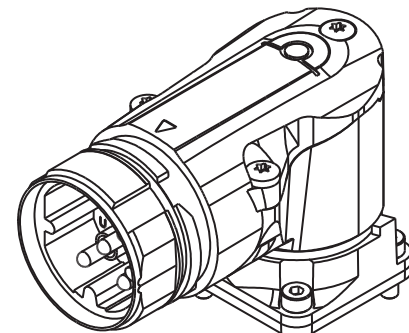

SFD3/SFD-M

J- Connector Pinouts – Hybrid combined power and feedback for DSL for AKM2G7 > 20 Amps Continuous

J- Hybrid Power + HIPERFACE DSL Connector Option

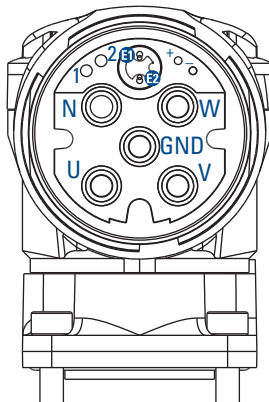

Power + HDSSL

Pin	Function
U	Phase U
V	Phase V
W	Phase W
N	N/C
GND	PE
1	Brake +
2	Brake -
+	N/C
-	N/C
E2	HDSSL -
E1	HDSSL +

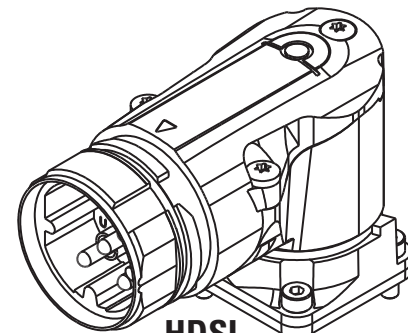

HDSSL

AKM2G Technical Guide

I. L₁₀ Bearing Fatigue

AKM2G-2x Motors - 20,000 hrs. L₁₀ Bearing Life

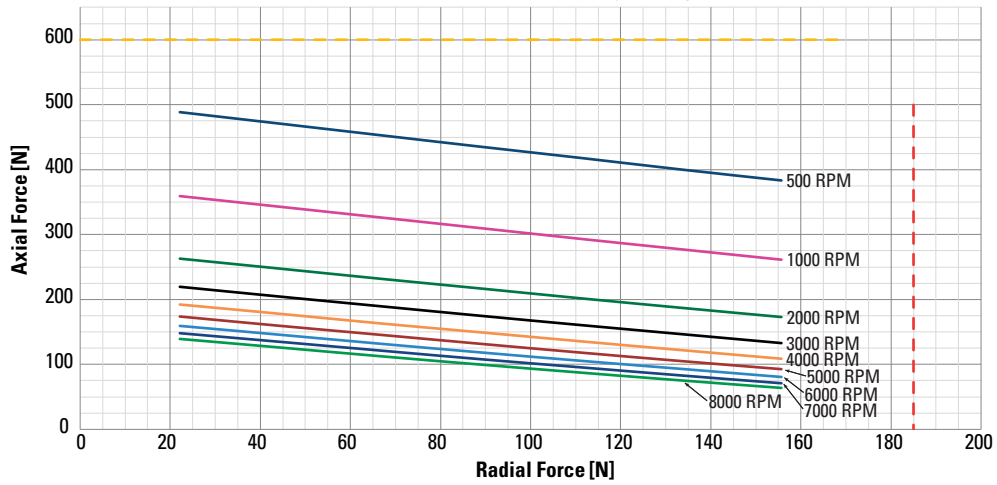

AKM2G-3x Motors - 20,000 hrs. L₁₀ Bearing Life

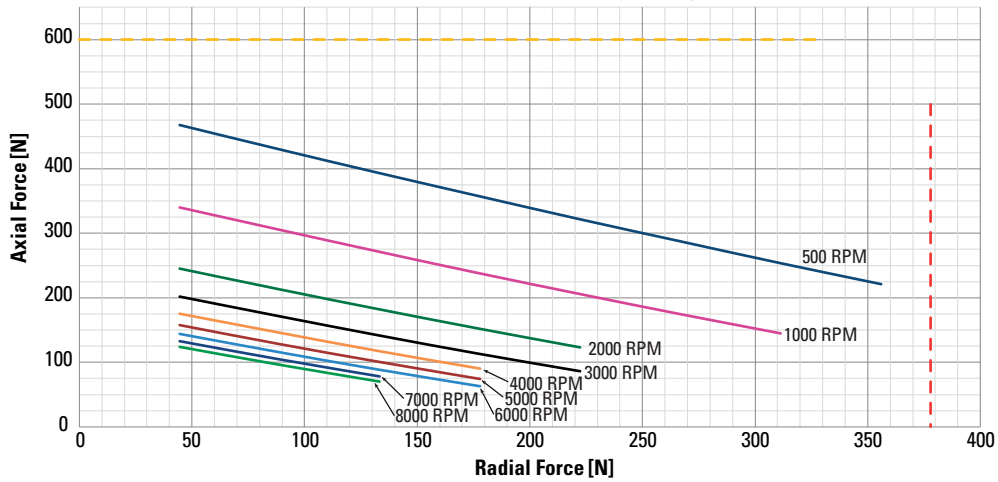

AKM2G-4x Motors - 20,000 hrs. L₁₀ Bearing Life

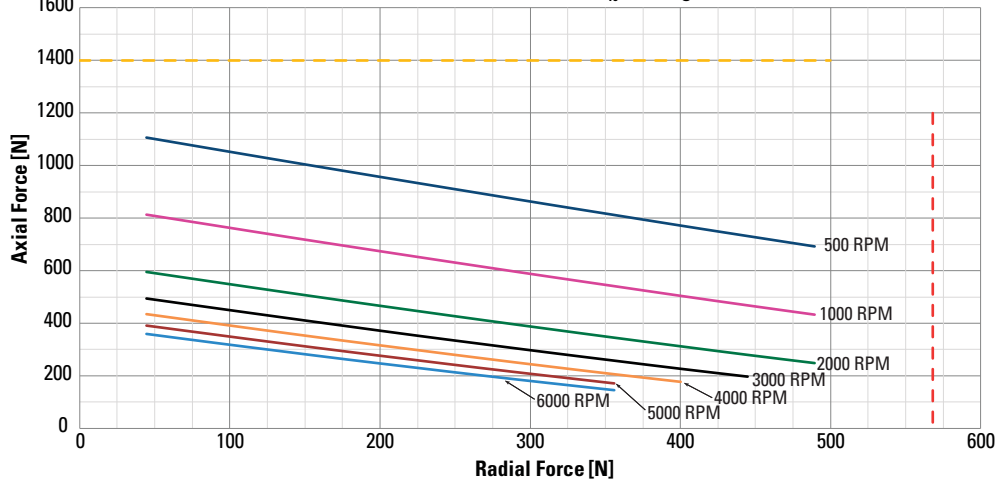

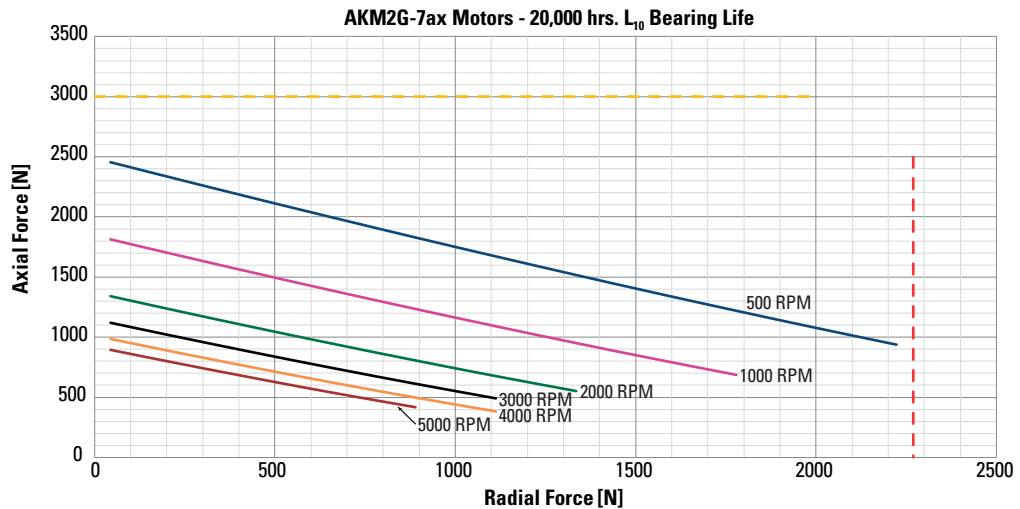
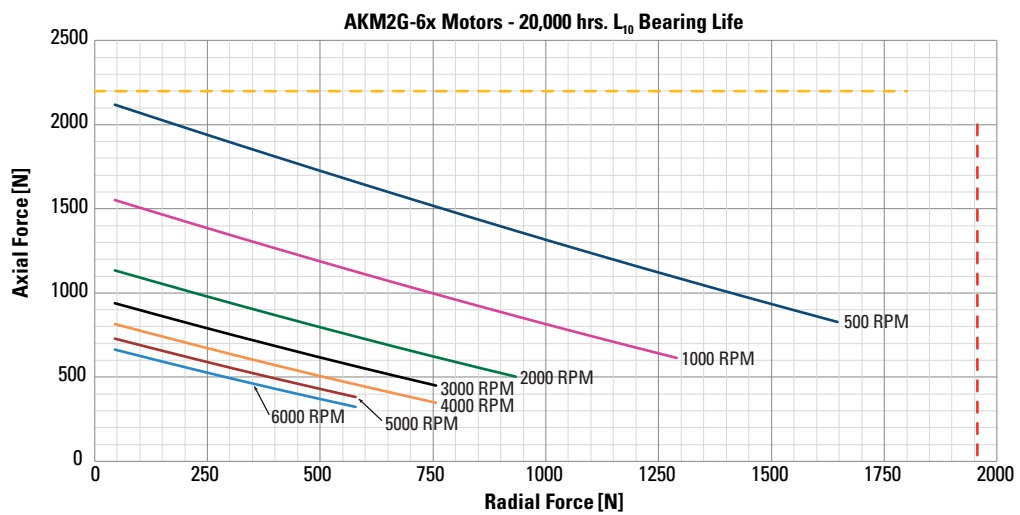
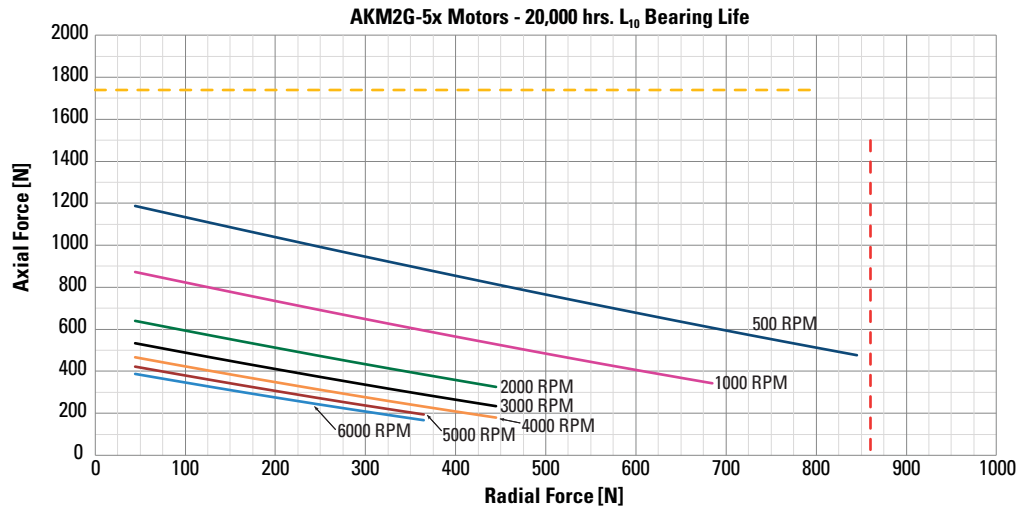

AKM2G Technical Guide

II. Shaft Loading

Motor	Max. Radial Force (N)	Max. Axial Force (N)
AKM2G-2	195	600
AKM2G-3	340	600
AKM2G-4	560	1400
AKM2G-5	890	1740
AKM2G-6	2000	2200
AKM2G-7	2670	3000

The maximum radial load ratings reflect the following assumptions:

1. Motors are operated with peak torque of the longest member of the frame size.
2. Fully reversed load applied to the end of the smallest diameter standard mounting shaft extension.
3. Infinite life with 99% reliability.
4. Safety factor = 2.

AKM2G-2x Motors - Radial vs. Shaft Position

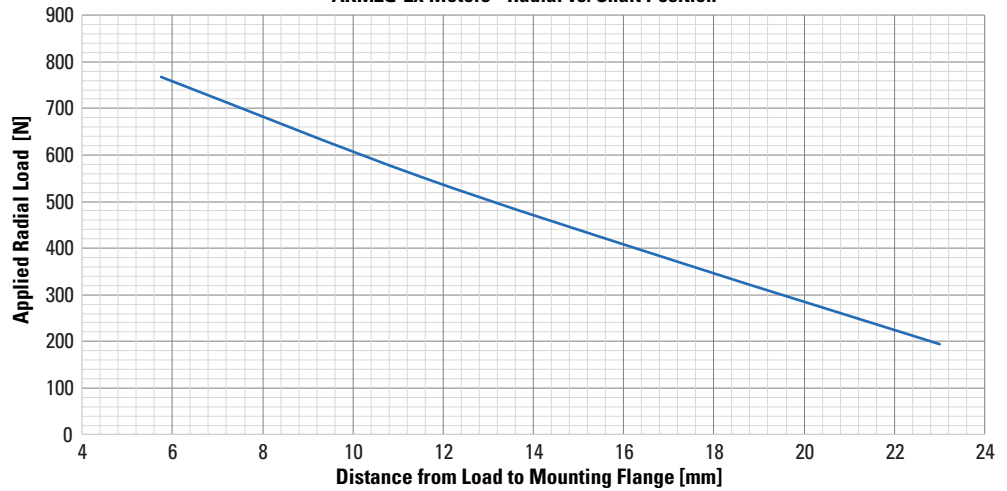

AKM2G-3x Motors - Radial vs. Shaft Position

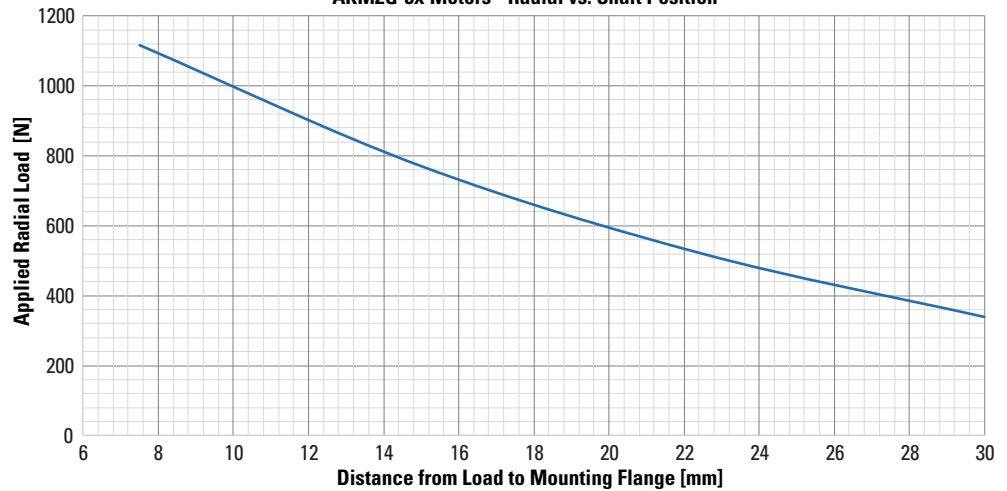

AKM2G-4x Motors - Radial vs. Shaft Position

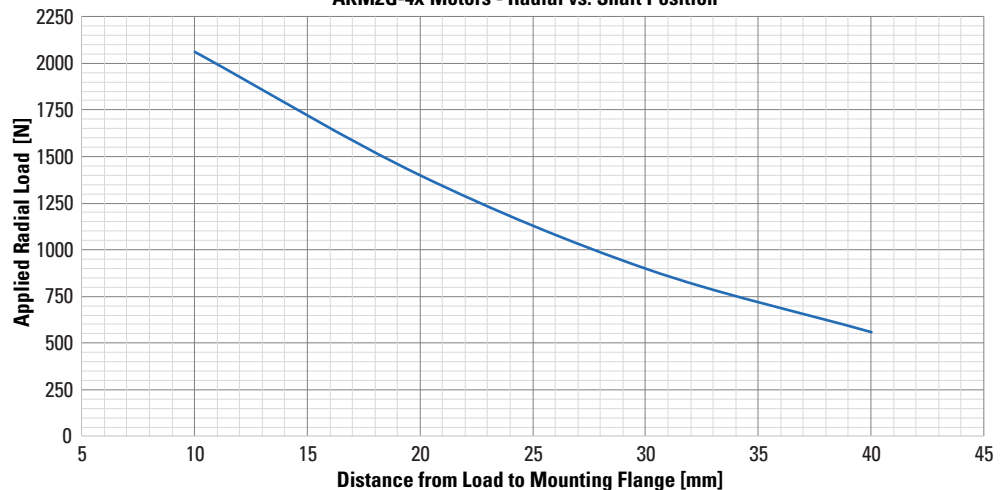

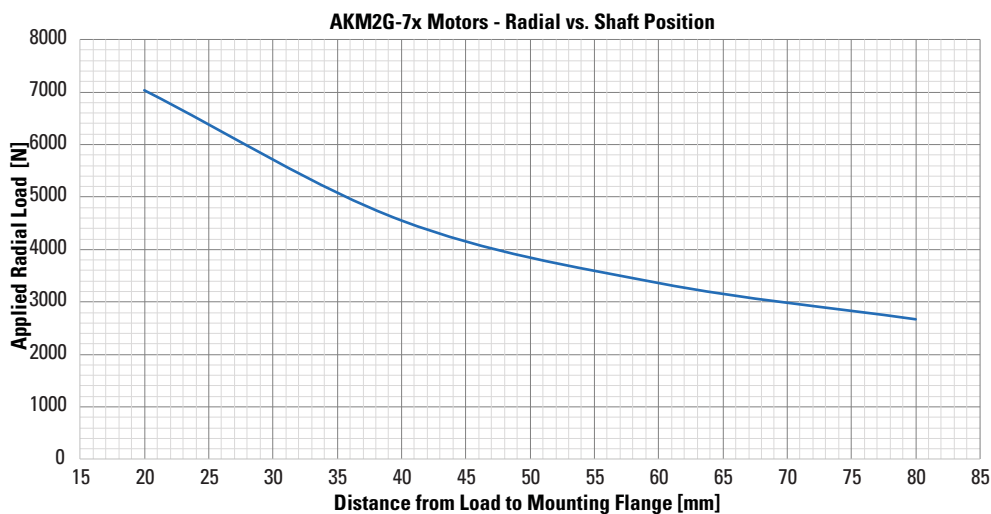
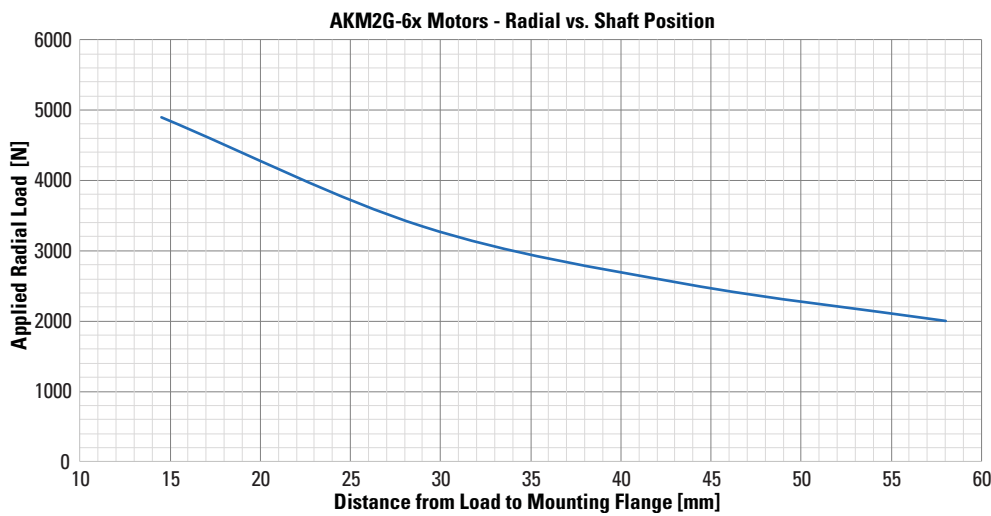
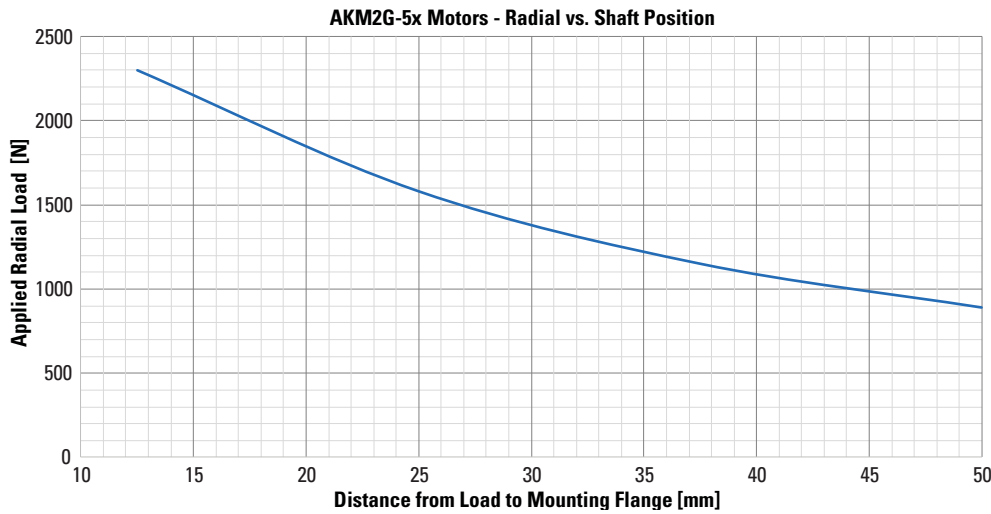

III. Mineral-filled PTFE Teflon Shaft Seals

There is a normal break-in period for our Mineral-filled PTFE Teflon shaft seals. Best conditions during the break-in period would be at the operational temperature and speed that would be typical for the application.

During the break-in period, some “shedding” of mineral-filled PTFE Teflon material is normal. The debris is not a sign of seal deterioration or failure. The material “shed” should be reduced with usage.

Typically, a few hours at operational speed is enough to break-in the shaft seal.

AKM2G Technical Guide

IV. Thermal Sensor Protective Devices

AKM2G Thermal Sensor Protective Devices

The standard version of each motor is fitted with an electrically isolated PT-1000. The thermal sensors do not provide any protection against short, heavy overloading.

The motor can be delivered with a PT-1000 + PTC, PTC, or KTY 84-130 equivalent sensors optionally (see Thermal Sensor options 2, 3, 0).

With digital feedback systems SFD3 (CA), SFD-M (CB), Hiperface DSL (GU) and EnDat 2.2 (LD) the temperature sensor status is transmitted digitally and evaluated in the drive.

Provided that our configured feedback cables are used, the sensor is integrated into the monitoring system of the digital servo amplifiers.

Thermal Device Options: Resistance vs. Temperature Graphs

Kollmorgen AKD drives can directly interpret information from the motor thermal sensors to properly reflect the motor winding temperature. For other drives please refer to the graph Delta Between Motor Winding and Thermal Device on the following page.

Standard 1

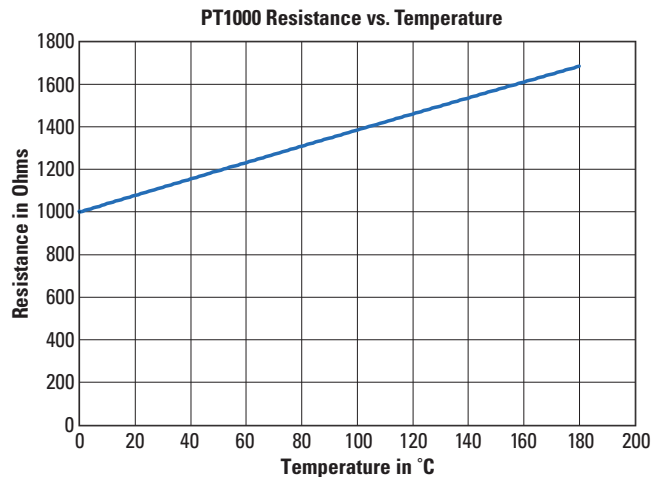

Option 2

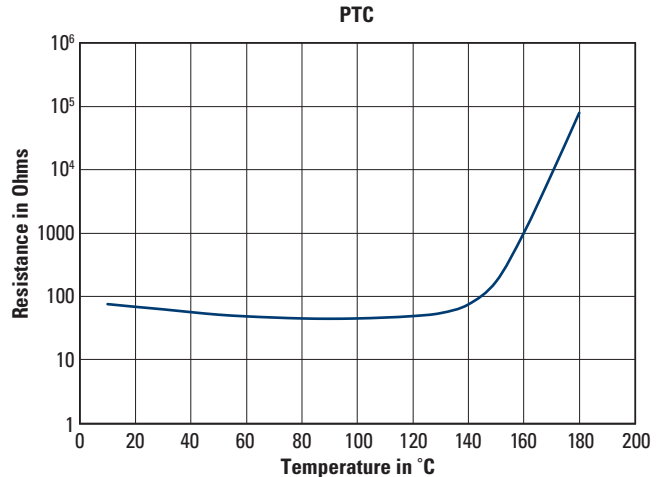

Option 3

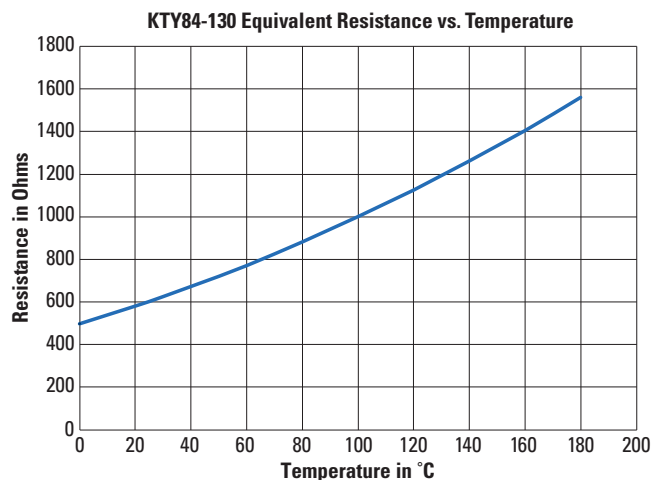

Option 0

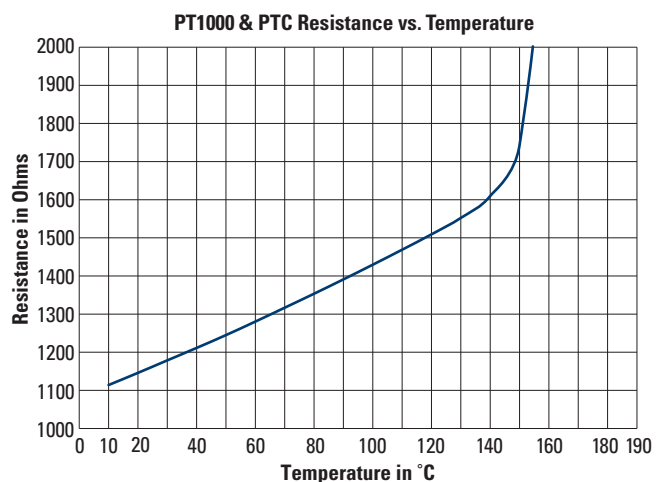

V. Delta Between Motor Winding and Thermal Device

When using a drive other than the Kollmorgen AKD you will need to account for the difference (Delta) in temperature between the value reported by the thermal sensor and the actual motor winding temperature. This is necessary to insure proper operation and protection of the motor.

The provided graph shows the delta between the reported device temperature on the x axis and the motor winding temperature on the y axis and should be used to adjust the response of the system for the difference between the thermal sensors reported temperature and the actual motor winding temperature.

Examples:

At 60 °C on thermal device temperature the winding temperature will be 1.8 °C higher (61.8 °C).

At 130 °C on thermal device temperature the winding temperature will be 8.1 °C higher (138.1 °C).

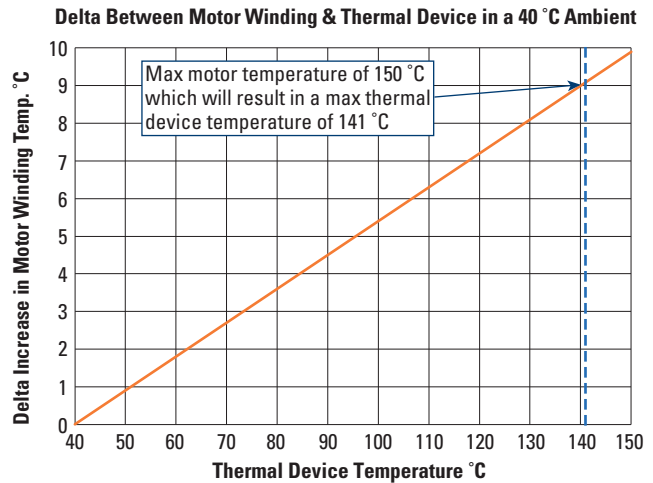

VI. Motor Phasing Diagram

When the motor is rotated clockwise (CW) as viewed from front shaft end, the following BEMF voltage waveforms result:

- » Voltage phase-UV leads Voltage phase-VW by 120-degrees
- » Voltage phase-VW leads Voltage phase-WU by 120-degrees
- » Voltage phase-WU leads Voltage phase-UV by 120-degrees

BEMF Waveforms

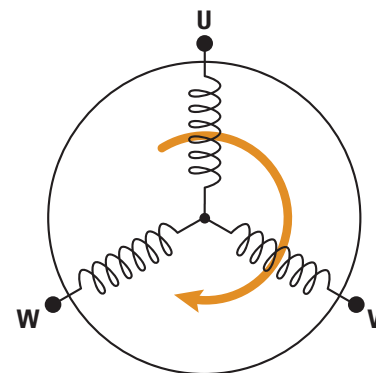
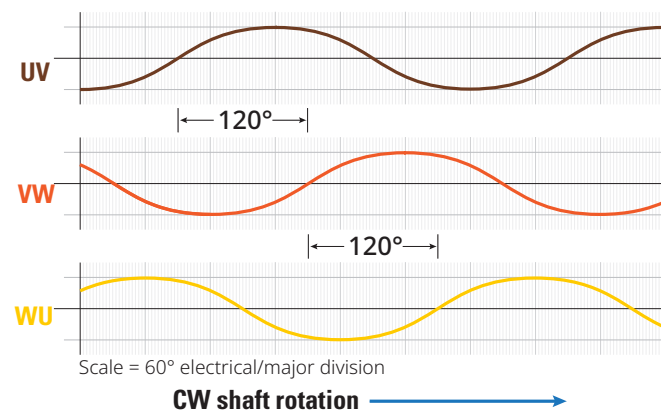

VII. Servo Motor Performance Curve Overview

How to Build a Servo Drive and Motor System

Performance data provided in this document is designed to help you select the optimum brushless servo motor.

Drive and Motor Performance Curves

The performance characteristics of a brushless servo system (motor/drives combination) are described by a torque/speed operating envelope. As shown above, the shaded areas of the curve indicate the continuous duty and intermittent duty zones of the system.

Continuous Duty Zone

The continuous duty zone is bordered by the continuous torque line up to the intersection with the intermittent duty line. The continuous torque line is set by either the motor's maximum rated temperature, or the drives' rated continuous current output, whichever is less. The system voltage limit line is set by the voltage rating of the drives, the line voltage supplied, and the motor winding. The system can operate on a continuous basis anywhere within this area, assuming the ambient temperature is 40 °C or less.

Intermittent Duty Zone

The intermittent duty zone is bordered by the peak torque line and the system voltage limit line. The peak torque line is set by either the drives' peak current rating, which the drive can produce for a limited time, or the maximum rated peak current for the motor, whichever is less. Refer to the Performance Data pages for each frame size. Note: Higher torque levels may be achievable at higher power levels.

Consult Kollmorgen Customer Support for more details. The system voltage limit line is set by the voltage rating of the drive, the line voltage applied and the motor winding. Operation in the intermittent zone must be limited to a duty cycle that will produce an RMS system torque falling within the continuous duty area. The RMS torque value is a function of the magnitude of the intermittent torque and the percentage of the time spent at that torque.

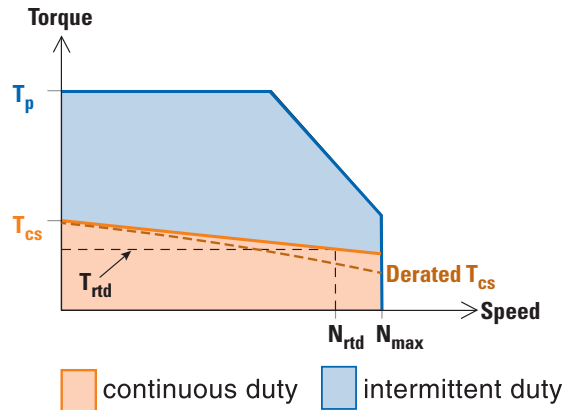

Definitions

T_p	Peak torque
T_{cs}	Continuous torque
T_{rtd}	Continuous rated torque (torque at rated power)
Derated T_{cs}	Maximum continuous torque with derating motor options (feedback type, shaft seal and brake)
N_{max}	Maximum speed
N_{rtd}	Rated speed (speed at rated power)

Performance Derating

Feedback, brake, and shaft seal options reduce, or derate, the continuous motor torque as shown by the Derated T_{cs} curve above. Kollmorgen documented performance data and curves, unless specified otherwise, are generated based on motors using resolver feedback, no brake and no shaft seal. Derate is taken into account when using the Kollmorgen Performance Curve Generator, or Motioneering Application.

Derate curves are provided to help determine the continuous torque of a motor with other combinations of feedback, shaft seal, and brake when referencing documented performance data and curves.

Derate Calculations

Derate is calculated by multiplying the continuous torque value (T_{CS}) by the percent derate for the appropriate feedback/seal option, either with or without brake at the desired speed point. Also, use the correct derate graph for the motor based on whether it will have a brake or no brake. Operating intermittently and/or at less than rated temperatures will reduce the derate. Kollmorgen Customer Support is available to discuss the specifics of your application and optimum sizing.

Derate curves shown for each motor variation assume continuous operation at the selected speed and at maximum rated temperature.

Example:

For an AKM2G-23F motor with SFD feedback, shaft seal and brake, operating at 3000 RPM the continuous torque (T_{CS}) is reduced to 90% of its value without the derating options. Multiply the motor torque value (T_{CS}) by 0.90 for the derated torque (Derated T_{CS}) at 3000 RPM. For ease of graph interpretation, using a Derate that is a rounded approximation is acceptable. For exact values, refer to Kollmorgen's online Motioneering Application, or Performance Curve Generator.

AKM2G-2x Performance Data - Up to 480 Vac voltage

Parameters	Tol	Symbol	Units	AKM2G-21			AKM2G-22			AKM2G-23		
				D	E	G	D	E	D	E	F	
Max Rated Equivalent Line Voltage	Max	V_{bus}	Vac	480	240	120	480	240	480	480	240	
Max Continuous Torque for ΔT winding = 100°C	Nom	T_{mc}	Nm	0.636	0.642	0.649	1.11	1.11	1.11	1.48	1.48	
			lb-in	5.62	5.68	5.75	9.80	9.81	9.86	13.1	13.3	
							2.37	2.93	1.150	1.151	1.168	
							7.62	7.64	10.2	10.2	10.3	

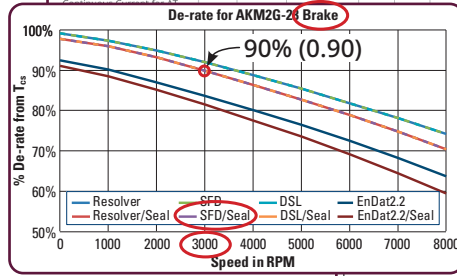

Documented table & curve - resolver feedback no shaft seal no brake

$$\text{Derated } T_{CS} = T_{CS} \cdot \% \text{Derate}$$

$$= 1.50(0.90)$$

$$= 1.35 \text{ Nm @ 3000 rpm}$$

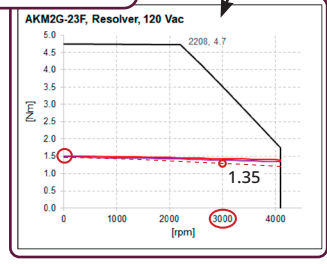

Generating Performance Curves

Kollmorgen offers two options, the Performance Curve Generator and Motioneering Sizing Application, for the AKM family of servo motors as well as TBM, TBM2G, and KBM frameless motors. These applications have any derating factored into the generated curves.

Kollmorgen Performance Curve Generator

Performance Curve Generator : AKM2G-21D

Speed vs. Torque
Torque Units: Nm

SAVE SHARE URL PRINT

Motor Parameters: Ambient Temp (°C) 40

Amplifier Parameters: Voltage (V) 120, 240, 400, 480

Feedback: Hyperface DSL, SFD3, Resolver, EnDat2.2

Motor Parameters: Continuous Torque 1.117, T_{CS} @ 25°C 1.117, T_{CS} @ 100°C 1.207, Continuous Torque 0.611, Power 0.172

Drive Parameters: 2545.795



<https://www.kollmorgen.com/en-us/service-and-support/technical/performance-curve-generator>

Motioneering Application Curve Generator

KOLLMORGEN Motioneering My Projects Catalog CONTACT US English user@kollmorgen.com

System Details: AKM2G-21D/AKD-x00306 (120 V)

Motor: AKM2G-21D (120 V)

Max Speed: 4800 RPM

Rated Power: 293 Watts

Continuous Torque: 0.636 N-m

Peak Torque: 1.78 N-m

Continuous Current: 2.17 amps

Peak Current: 5.86 amps

Rotor Inertia: 9.30E-005 kgm²

Torque Sensitivity: 0.296 N-m/A

Back EMF Constant: 19.5 V/RPM

Ambient Temp.: 40.0 deg. C

Amp: AKD-x00306

Input Voltage: 240 volts

Frequency: 50 or 60 Hz

Max. Bus Voltage: 420 volts

Cont. Current: 3.00 amps

Peak Current: 9.00 amps

Time @ peak current: 5.00 sec

Operating temperature: 0 to 40 deg. C

Storage temperature: -25 to 55 deg. C

Humidity: 95 %

Form factor: 1.01 RMS/Avg. current

Performance Curve: Endat Seal Brake

Speed (RPM)

Torque (Nm)

Continuous Intermittent

Show Speed on X-Axis



<https://www.kollmorgen.com/en-us/service-and-support/technical/motioneering-online>

Notes

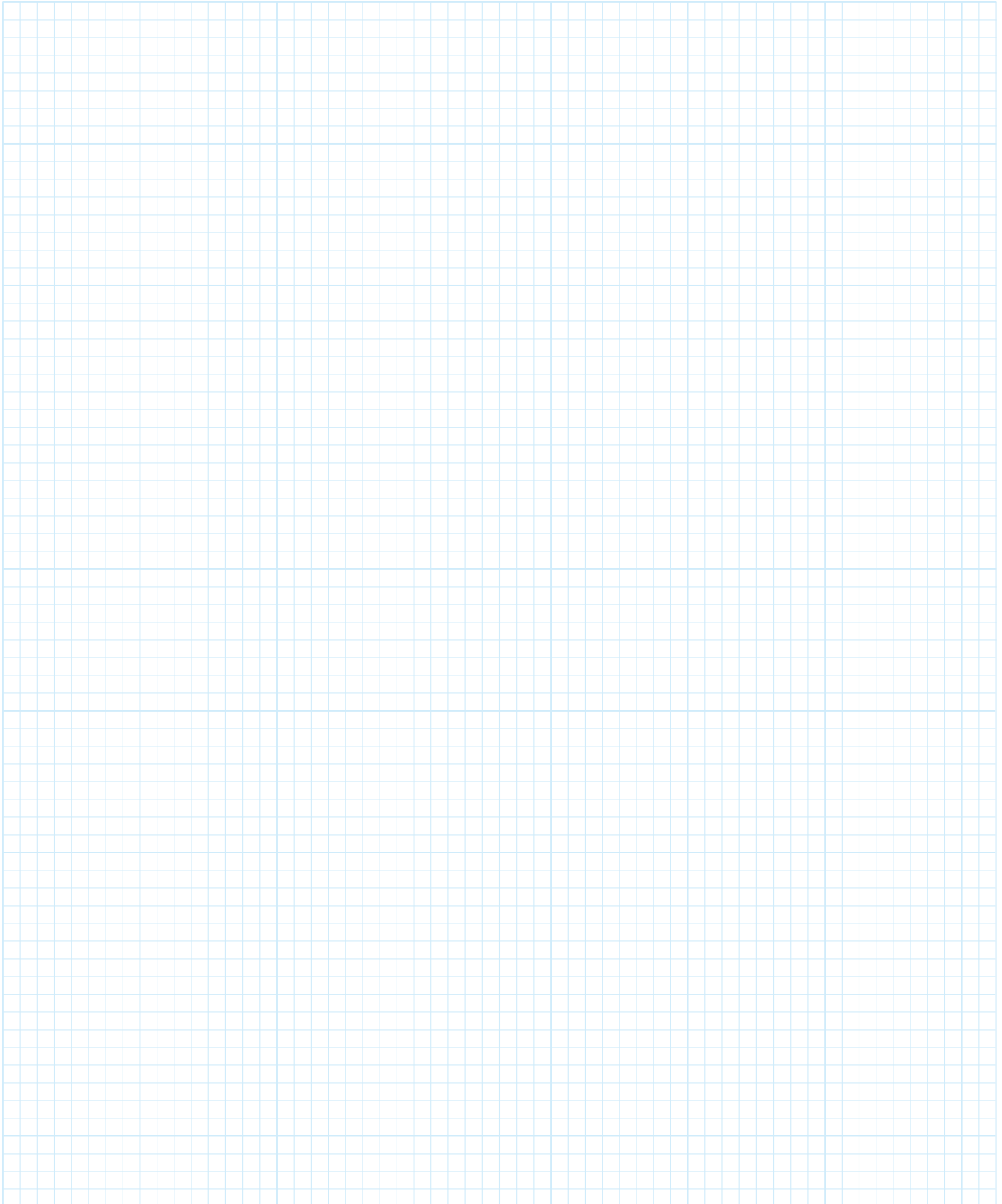

0.125 inch divisions

Motors – Copyrights, Trademarks, and Disclaimers

Copyright 2026 Regal Rexnord Corporation, All Rights Reserved.

Information in this document is subject to change without notice. The software package described in this document is furnished under a license agreement. The software package may be used or copied only in accordance with the terms of the license agreement.

This document is the intellectual property of Kollmorgen and contains proprietary and confidential information. The reproduction, modification, translation or disclosure to third parties of this document (in whole or in part) is strictly prohibited without the prior written permission of Kollmorgen.

Kollmorgen Trademarks

Regal Rexnord and [Kollmorgen](#) are trademarks of [Regal Rexnord Corporation](#) or one of its affiliated companies.

These trademarks or trade names are owned by or under the control of Regal Rexnord Corporation or any of its affiliates:

- | | | | |
|--------------------------------|-------------------------------|----------------------------|----------------------|
| » Kollmorgen Essentials System | » AKME | » Kollmorgen Visualization | » SafeMotion Monitor |
| » Kollmorgen Essentials Cable | » AKMH | » Builder | » Servostar |
| » Kollmorgen Essentials Drive | » BLM | » KVB | » SMM |
| » Kollmorgen Essentials Motor | » Cartridge DDR | » MKD | » TBM |
| » AKD | » DDL | » Motioneering | » TBM2G |
| » AKD2G | » DDR | » P8000 | » WorkBench |
| » AKD PDMM | » GoldLine | » PCMM | |
| » AKM | » Kollmorgen Automation Suite | » PCMM2G | |
| » AKMA | » KAS | » PowerMax | |

Other Trademarks

Any of these other trademarks and/or trade names may be used and/or identified in Kollmorgen products, firmware, and/or software.

These are believed to be the trademarks and/or trade names of their respective owners and are not owned or controlled by Regal Rexnord Corporation:

- | | |
|---|---|
| » BiSS: iC-Haus GmbH. | » LOCTITE 640: HenkeAG & CO. KGAA. |
| » CANopen: CAN in Automation (CIA). | » LOCTITE: HenkeAG & CO. KGAA. |
| » DRIVE-CLiQ: Siemens Aktiengesellschaft. | » Modbus: Schneider Electric USA, Inc. |
| » EnDat: Dr. Johannes Heidenhain GmbH. | » MOLYKOTE: DDP Specialty Electronic Materials US 9, LLC. |
| » EtherCAT and Safety over EtherCAT: Beckhoff Automation GmbH. | » Mylar: DUPONT Teijin Films U.S. |
| » EtherCAT: Beckhoff Automation GmbH. | » PHOENIX CONTACT: Phoenix Contact GmbH & Co. KG. |
| » EtherNet/IP Communication Stack: RockwellAutomation. | » PROFINET: PROFIBUS Nutzerorganisation e.V. |
| » EtherNet/IP: ODVA, Inc. | » Scotch-Weld 2214: 3M Company. |
| » Ghostsript : Artifex Software, Inc. (distributed under the AGPL license). | » sercos: Sercos InternationaE.V. |
| » HIPERFACE DSL: SICK AG. | » SIMATIC: Siemens Aktiengesellschaft. |
| » HIPERFACE: SICK AG. | » SpeedTec: Liqui-Moly GmbH or TE Connectivity IndustriaGmbH. |
| » Hysol: HysoHuawei Electronics Co.,LTD. | • If SpeedTec is used as a lubricant, it belongs to Liqui-Moly GmbH. |
| » IECEx: InternationaElectrotechnicaCommission (IEC). | • If SpeedTec is used as a connector, it belongs to TE Connectivity IndustriaGmbH |
| » Instapak: Sealed Air Corporation. | » Teflon: The Chemours Company FC, LLC. |
| » INTERCONTEC: INTERCONTEC Pfeiffer Industrie-Steckverbindungen GmbH. | » Windows: Microsoft Corporation. |

Disclaimers

Technical changes which improve the performance of the device may be made without prior notice!

This document is the intellectual property of Kollmorgen. All rights reserved. No part of this work may be reproduced in any form (by photocopying, microfilm or any other method) or stored, processed, copied or distributed by electronic means without the written permission of Kollmorgen.

The information in this document is believed to be accurate and reliable at the time of its release. Kollmorgen assumes no responsibility for any damage or loss resulting from the use of this help, and expressly disclaims any liability or damages for loss of data, loss of use, and property damage of any kind, direct, incidental or consequential, in regard to or arising out of the performance or form of the materials presented herein or in any software programs that accompany this document.

Technische Änderungen, die der Verbesserung der Geräte dienen, vorbehalten!

Dieses Dokument ist geistiges Eigentum von Kollmorgen. Alle Rechte vorbehalten. Kein Teil dieses Werkes darf in irgendeiner Form (Fotokopie, Mikrofilm oder in einem anderen Verfahren) ohne schriftliche Genehmigung von Kollmorgen reproduziert oder unter Verwendung elektronischer Systeme verarbeitet, vervielfältigt oder verbreitet werden.

Die Genauigkeit und Verlässlichkeit der Informationen in diesem Dokument entspricht dem Kenntnisstand zum Zeitpunkt der Veröffentlichung. Kollmorgen übernimmt keine Verantwortung für Schäden oder Verluste, die sich aus der Verwendung dieser Hilfe ergeben, und lehnt ausdrücklich jegliche Haftung sowie Schadensersatzansprüche für Datenverlust, entgangene Nutzung und Sachschäden jeglicher Art ab, inklusive direkter, zufälliger oder Folgeschäden im Zusammenhang mit der Funktion oder Form des hierin oder in einem der mit diesem Dokument gelieferten Software enthaltenen Materials.



Motors – Copyrights, Trademarks, and Disclaimers

Disclaimers (continued)

Es posible que se implementen sin aviso previo cambios técnicos que mejoran el rendimiento del dispositivo.

La propiedad intelectual de este documento pertenece a Kollmorgen. Todos los derechos reservados. Se prohíbe la reproducción de este documento por ningún medio (fotocopia, microfilm u otro método), así como su almacenamiento, procesamiento, copia o distribución por medios electrónicos, sin el consentimiento por escrito de Kollmorgen.

La información incluida en este documento se considera correcta y confiable en el momento de su publicación. Kollmorgen no asume ninguna responsabilidad por ningún daño o pérdida causados por el uso de este documento de ayuda y rechaza explícitamente toda responsabilidad o daño por pérdida de datos, pérdida de uso y daños en la propiedad de cualquier tipo, ya sea directos, incidentales o consecuentes, en relación con el rendimiento o la forma de los materiales aquí publicados, o con los programas de software que acompañan a este documento, o que surjan de estos.

Les modifications techniques qui améliorent les performances du dispositif peuvent être apportées sans avis préalable !

Ce document est la propriété intellectuelle de Kollmorgen. Tous droits réservés. Aucune partie de ce document ne peut être reproduite sous quelque forme que ce soit (photocopie, microfilm ou autre méthode) ni stockée, traitée, copiée ou distribuée de manière électronique sans l'autorisation écrite de Kollmorgen.

Les informations contenues dans ce document sont considérées exactes et fiables au moment de leur publication. Kollmorgen n'assume aucune responsabilité pour tout dommage ou perte résultant de l'utilisation de cette aide, et rejette expressément toute responsabilité ou tous dommages pour la perte de données, la perte d'utilisation et les dommages matériels de toute nature, directs, accessoires ou indirects, en ce qui concerne ou découlant des performances ou de la forme des matériaux présentés ici ou dans tout programme logiciel accompagnant ce document.

Modifiche tecniche volte a migliorare le prestazioni del dispositivo possono essere apportate senza preavviso.

Il presente documento è proprietà intellettuale di Kollmorgen. Tutti i diritti riservati. È vietata la riproduzione di qualsiasi parte di quest'opera in qualsiasi forma (fotocopia, microfilm o qualunque altro metodo) così come la memorizzazione, il trattamento, la copia o la distribuzione tramite mezzi elettronici senza l'autorizzazione scritta di Kollmorgen.

Le informazioni contenute nel presente documento sono ritenute accurate e affidabili al momento della pubblicazione. Kollmorgen non si assume alcuna responsabilità per eventuali danni o perdite risultanti dall'uso di questa guida e declina espressamente qualsiasi responsabilità o danni dovuti a perdita di dati, mancato utilizzo e danni materiali di qualunque tipo, diretti, accidentali o consequenziali, in relazione a o derivanti dal funzionamento o dalla forma dei materiali presentati qui o in eventuali programmi software che accompagnano il presente documento.

デバイス性能の向上のため、予告なく技術的な変更が実装される場合があります。

本書の知的財産権はKollmorgenに帰属しており、無断複写・転載は禁じられています。本書のいずれの部分も、Kollmorgenの書面による許可なしに、いかなる複製(写真、マイクロフィルムまたはその他の手段)、保管、改変、複写または電子的配布を行うことはできません。

本書に記載されている情報は、発行時において正確かつ信頼できるものですが、Kollmorgenはこのヘルプの使用により生じるいかなる損害や損失についても責任を負いません。また、本書の履行、資料形式または付随するあらゆるソフトウェアプログラムに関連して、あるいはこれらが原因で発生する、直接的、偶発的または結果的な、いかなるデータの損失、利用機会の喪失および財産の損害に対しても、一切の責任や損害賠償を明示的に否認します。

기기의 성능을 향상시키는 기술적 변경 사항은 사전 공지 없이 이루어질 수 있습니다

본 문서의 지적 재산권은 Kollmorgen에 있습니다. All rights reserved. 본 저작물의 어떤 부분도 Kollmorgen의 서면 허가 없이 어떠한 형태(사진 복사, 마이크로필름 또는 기타 방법)로도 복제하거나 전자 수단으로 저장, 처리, 복사 또는 배포할 수 없습니다.

본 문서의 정보는 공개 시점을 기준으로 정확하고 신뢰할 수 있는 것으로 간주됩니다. Kollmorgen은 본 도움말의 사용으로 인한 어떠한 피해나 손실에 대해 책임을 지지 않으며, 본 문서 또는 본 문서와 함께 제공되는 소프트웨어 프로그램에 제시된 자료의 성능 또는 형태와 관련하여 또는 그로 인해 직접적, 우발적 또는 결과적으로 발생한 모든 유형의 데이터 손실, 사용 손실, 재산상의 피해에 대한 책임이나 손해를 명시적으로 부인합니다.

Alterações técnicas que melhoram o desempenho do dispositivo podem ser feitas sem aviso prévio!

Este documento é propriedade intelectual da Kollmorgen. Todos os direitos reservados. Nenhuma parte deste trabalho pode ser reproduzida sob qualquer forma (por fotocópia, microfilme ou qualquer outro método) ou armazenada, processada, copiada ou distribuída por meios eletrônicos sem a permissão escrita da Kollmorgen.

Acredita-se que as informações contidas neste documento sejam precisas e confiáveis no momento de sua divulgação. A Kollmorgen não assume nenhuma responsabilidade por quaisquer danos ou perdas resultantes do uso desta ajuda, e se isenta expressamente de qualquer responsabilidade ou danos por perda de dados, perda de uso e danos materiais de qualquer espécie, direta, incidental ou subsequente em relação a ou resultante do desempenho ou da forma dos materiais apresentados aqui ou em quaisquer programas de software que acompanhem este documento.

我们可能会进行技术更改以提高设备性能，恕不另行通知！

本文档知识产权归 Kollmorgen 所有，Kollmorgen 保留所有权利。未经 Kollmorgen 书面许可，不得以任何形式（影印、缩微胶片或其他任何方式）复制本文档任何内容，亦不得以任何电子手段存储、处理、复制或分发本文档的任何内容。

据我们所知，本文档所含信息截至发布日是准确可靠的。对于因使用本帮助文档而导致的任何损害或损失，Kollmorgen 概不承担任何责任。Kollmorgen 特此明确声明，对于因本文档中的任何材料或随附本文档之任何软件程序的性能或形式导致的或与之相关的任何类型的数据丢失、使用中中断损失或财产损害（包括直接、间接和衍生性损失或损害），Kollmorgen 不承担任何法律责任或损害赔偿。

Complete Motion and Automation Solutions

The highest performance and the right fit for any application.



Online Design Tools

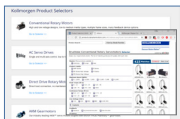

Product Selector
Quickly choose the ideal products for your application needs.



Motioneering
Size your motion system based on application requirements and motion profiles.

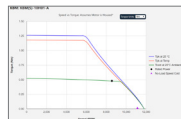

Performance Curve Generator
Optimize housed and frameless motor windings based on power and environmental factors.



3D Models
Visualize products in 3D and download CAD files for use in your design.

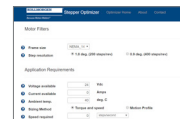

Stepper Optimizer
Interactively choose the most efficient stepper solution for your application.



AKD2G Safe Dynamic Brake Calculator
Specify and size the right braking components while saving development time.



Learn more and try our design tools now.

More Expertise for a More Successful Machine

Our global engineering, service and support network provides deep knowledge of all the major industries that rely on advanced motion control and automation technology. We offer world-class engineering expertise, self-service design tools, personalized field service, and easy access to our design, application and manufacturing centers in strategic locations across the globe.

About Kollmorgen

Kollmorgen, a Regal Rexnord brand, has more than 100 years of motion experience, proven in the industry's highest-performing, most reliable motors, drives, linear actuators, AGV (Automated Guided Vehicle) control solutions, and automation control platforms. We deliver breakthrough solutions that combine exceptional performance, reliability and ease of use, giving machine builders an irrefutable marketplace advantage.

KOLLMORGEN

A REGAL REXNORD BRAND

www.kollmorgen.com

© 2026 Kollmorgen Corporation. All rights reserved
See Copyrights, Trademarks, and Disclaimers for legal ownership.

KM_CA_000315_RevG_EN