

NUMBER <b>S6232C</b>	CATEGORY <b>Application Specification</b>	<b>Amphenol</b> COMMUNICATIONS SOLUTIONS	<b>Commercial Industrial</b>
TITLE <b>MSPE PLUG IDC TERMINATION</b>		ISSUED BY Ross D'Amico	REVISION 1.0
		APPROVED BY Kent Lambie	DATE MAY15/23

## 1. Overview

This specification covers the process for assembling a MSPE Series plug connector to a cable when using the IDC termination option.

## 2. Recommended Cable Specifications

ITEMS		SPECIFICATIONS	
CONDUCTORS	SIZE	26 AWG – 28 AWG	24 AWG – 25 AWG
	STRANDS	7 OR 19 STRANDS PER WIRE	7 OR 19 STRANDS PER WIRE
	MATERIAL	COPPER WIRE	
INSULATION OUTSIDE DIAMETER		Ø 0.95 – 1.05mm (Ø 0.037 – 0.041")	Ø 1.06 – 1.25mm (Ø 0.042 – 0.049")
BRAIDED SHIELD		TIN PLATED	
JACKET OUTSIDE DIAMETER		Ø 3.50 – 6.40mm (Ø 0.138 – 0.252")	
FOR MSPE SERIES PLUG FAMILY		MSPE-P2L0-8X0	MSPE-P2L0-4X0

## 3. Component Names

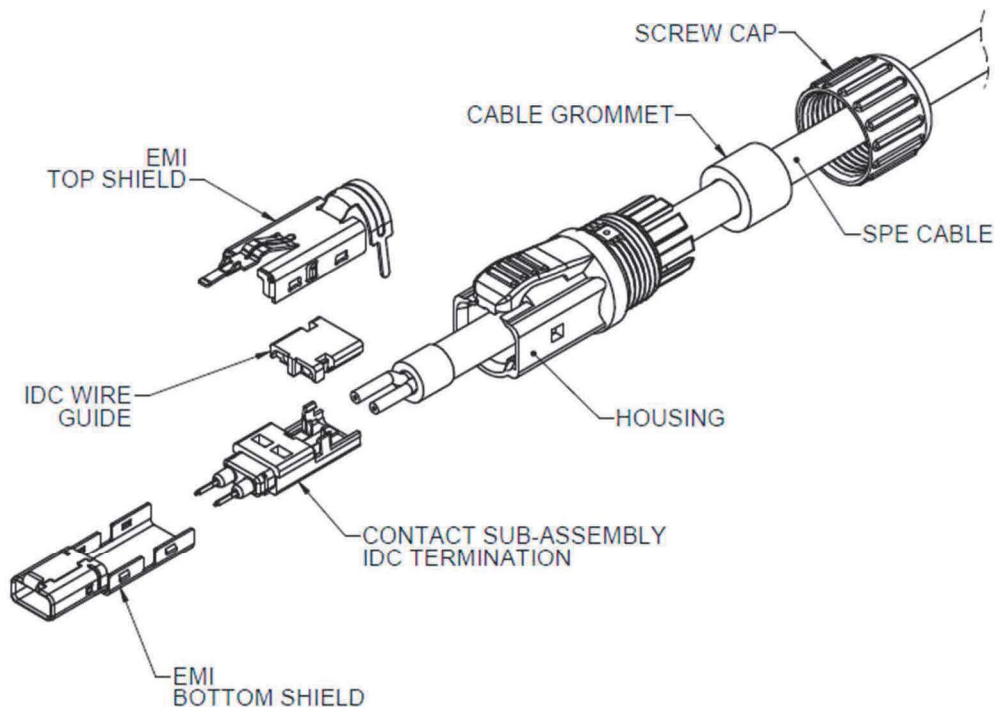

NUMBER <b>S6232C</b>	CATEGORY <b>Application Specification</b>	<b>Amphenol</b> COMMUNICATIONS SOLUTIONS	 <b>Commercial Industrial</b>
TITLE <b>MSPE PLUG IDC TERMINATION</b>		REVISION 1.0	DATE MAY15/23

#### 4. Contact Position Numbering

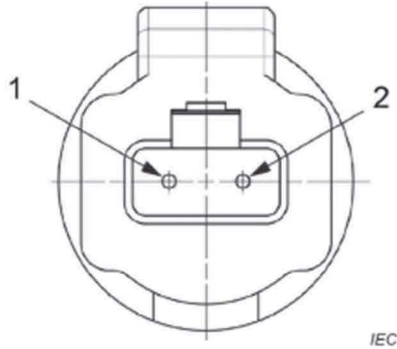

#### 5. Connector Pin Assignment

Pin No.	Signal
1	COM+
2	COM-

#### 6. Required Tools

The required tools and material examples for the cable assembly are listed below.

- Cable length (finished cable assembly length)
- Copper tape (3 – 5mm width)
- Crimp hand tool (for crimping top EMI shield to cable shield; MSPE-P2HT-01)
- Caliper or ruler (for cable termination length measurements)
- Cutters (for stripping cable jacket)
- Cable scissors (for cutting braided shield)
- Side cutters (for cutting core wires)

NUMBER <b>S6232C</b>	CATEGORY <b>Application Specification</b>	<b>Amphenol</b> COMMUNICATIONS SOLUTIONS	 <b>Commercial Industrial</b>
TITLE <b>MSPE PLUG IDC TERMINATION</b>		REVISION 1.0	DATE MAY15/23

## 7. Hand Tool

Hand tool (MSPE-P2HT-01) shown below, to be used for cable crimping. Refer to hand tool instruction manual, document #P-3091CF supplied with the tool.



## 8. Cable Preparation

### 8.1 Cable Length Required:

Allow 35mm length for connector use.

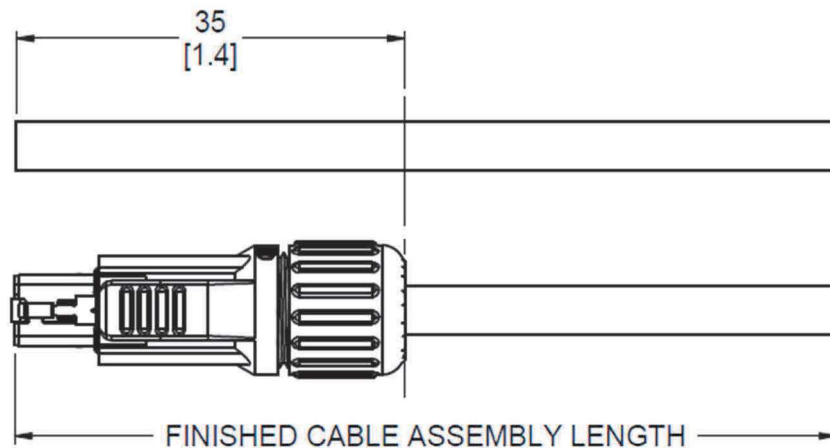

NUMBER <b>S6232C</b>	CATEGORY <b>Application Specification</b>	<b>Amphenol</b> COMMUNICATIONS SOLUTIONS	 <b>Commercial Industrial</b>
TITLE <b>MSPE PLUG IDC TERMINATION</b>		REVISION 1.0	DATE MAY15/23

### 8.2 Strip Cable Jacket:

Strip jacket 8 – 10mm (.31 – .39”) from front edge. Ensure to leave braided shield intact.

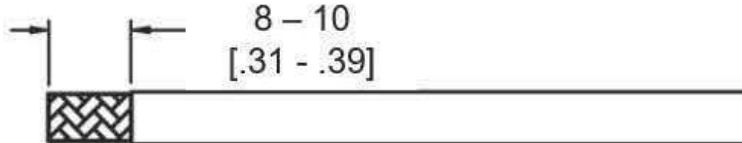

### 8.3 Braided Shield Placement:

Fold braided shield back over cable jacket and trim braided shield wires 3 – 4mm (0.12 – 0.16”) in length.

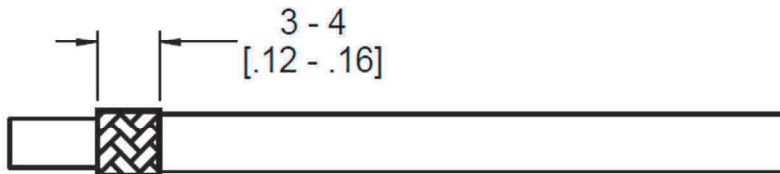

### 8.4 Individual Shield Removal:

Cut away any individual foil shields to expose all wires.



### 8.5 Apply Copper Tape:

Wrap copper tape tightly around the folded back braided shield. Wrap tape around for 1 to 2 rotations to cover entire braid and cable jacket to the length of 4 – 5mm (.16 – .20”). Excess tape thickness will interfere with later crimping process.

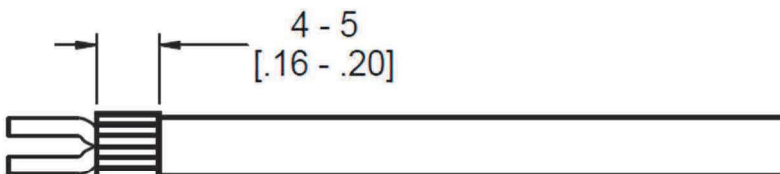

NUMBER <b>S6232C</b>	CATEGORY <b>Application Specification</b>	<b>Amphenol</b> COMMUNICATIONS SOLUTIONS	 <b>Commercial Industrial</b>
TITLE <b>MSPE PLUG IDC TERMINATION</b>		REVISION 1.0	DATE MAY15/23

## 9. IDC Termination

### 9.1 Wire Arrangement/Pre-assembly:

Arrange wires into one row based on pin assignments referenced in section 5. Assemble the following components onto the end of cable in the order specified, prior to wire termination:

1. Housing
2. Cable Grommet (If Applicable)
3. Screw Cap

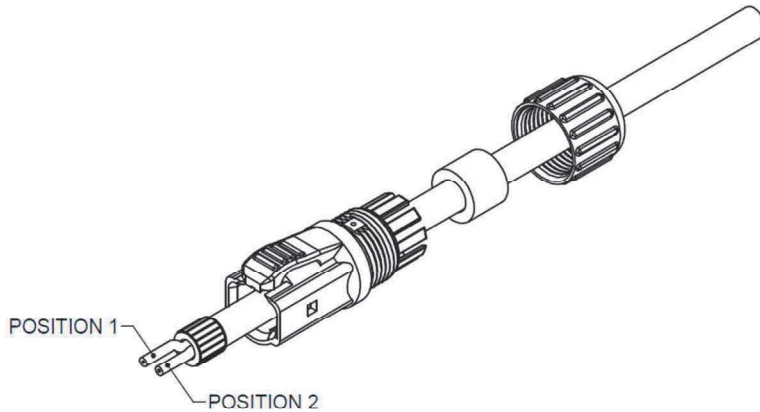

### 9.2 Wire Guide Cable Insertion:

Insert wires into wire guide ensuring orientation as shown below. See drawing P-MSPE-P2L0-XX0XX for appropriate plug kit size selection.

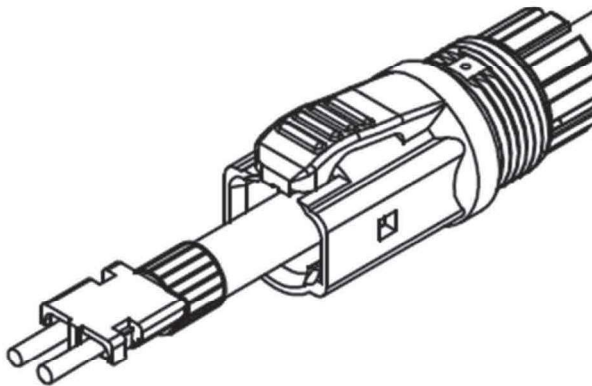

NUMBER <b>S6232C</b>	CATEGORY <b>Application Specification</b>	<b>Amphenol</b> COMMUNICATIONS SOLUTIONS	 <b>Commercial Industrial</b>
TITLE <b>MSPE PLUG IDC TERMINATION</b>		REVISION 1.0	DATE MAY15/23

### 9.3 Wire Trimming:

Position wire guide flat against copper tape as shown below and trim wires. Cut one side at a time positioning the cutter against each front wall of the wire guide.

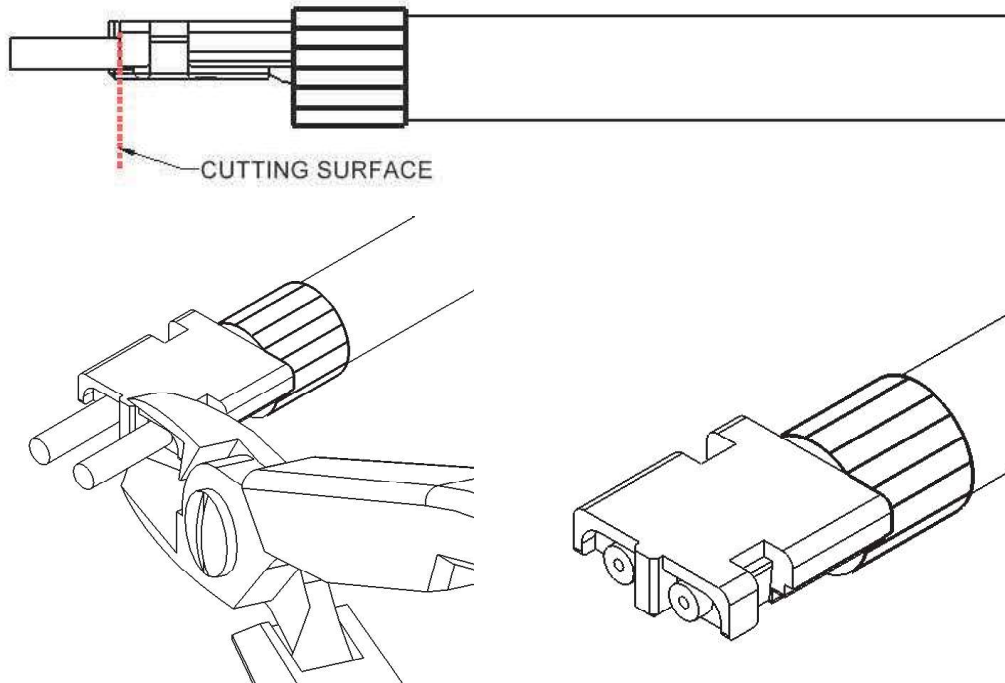

### 9.4 Wire Guide Position Set-up:

Position wire guide above IDC contact sub-assembly.

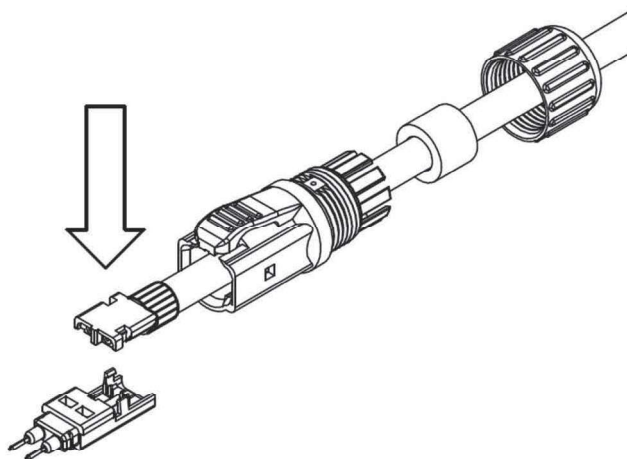

NUMBER <b>S6232C</b>	CATEGORY <b>Application Specification</b>	<b>Amphenol</b> COMMUNICATIONS SOLUTIONS	 <b>Commercial Industrial</b>
TITLE <b>MSPE PLUG IDC TERMINATION</b>		REVISION 1.0	DATE MAY15/23

9.5 Wire Guide Insertion:

Press wire guide with fingers to set guide in place. Ensure IDC contact blades are positioned within the slots of the IDC guide.

TOP VIEW

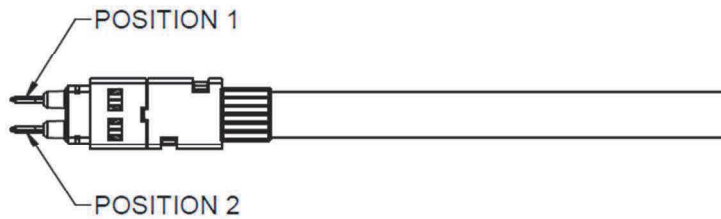

TOP VIEW WITH WIRE GUIDE HIDDEN

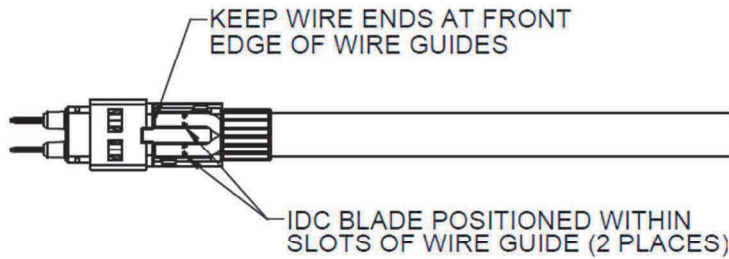

SIDE VIEW

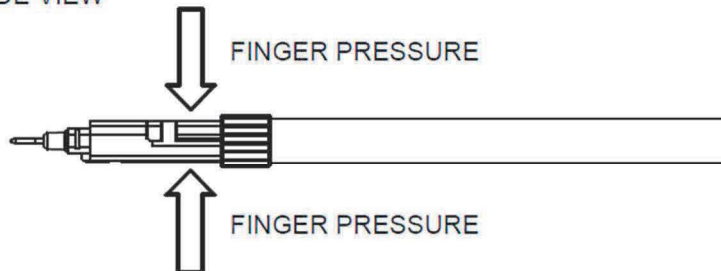

NUMBER <b>S6232C</b>	CATEGORY <b>Application Specification</b>	<b>Amphenol</b> COMMUNICATIONS SOLUTIONS	 <b>Commercial Industrial</b>
TITLE <b>MSPE PLUG IDC TERMINATION</b>		REVISION 1.0	DATE MAY15/23

## 10. Shield Assembly

### 10.1 Bottom Shield Insertion:

Assemble contact sub-assembly into bottom EMI shield. Ensure grooves in shield & insulator are aligned as shown in image below.

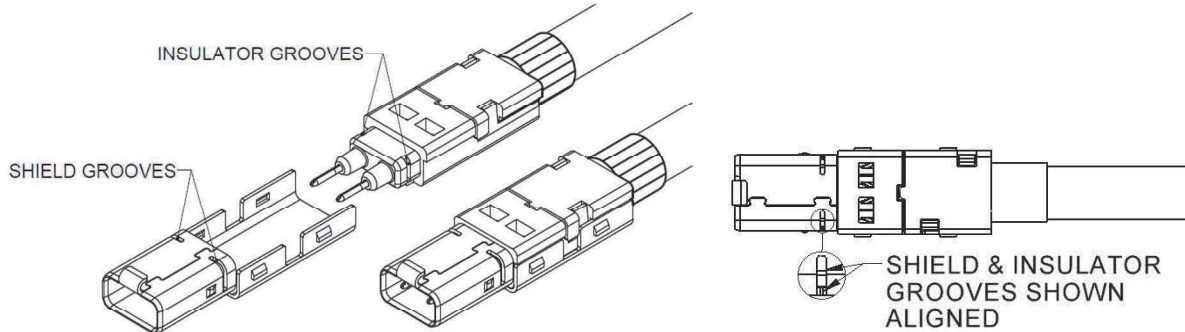

### 10.2 Top Shield Insertion:

Angle top EMI shield slightly. Ensure latch is captured by hook of bottom EMI shield. Incorrect assembly of top EMI shield may cause latch to malfunction.

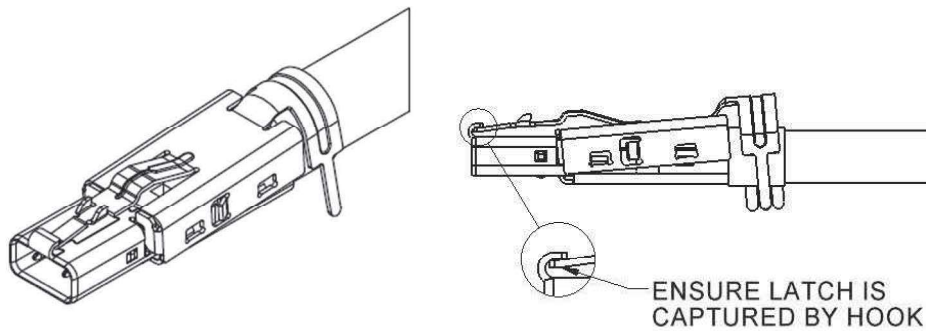

NUMBER <b>S6232C</b>	CATEGORY <b>Application Specification</b>	<b>Amphenol</b> COMMUNICATIONS SOLUTIONS	 <b>Commercial Industrial</b>
TITLE <b>MSPE PLUG IDC TERMINATION</b>		REVISION 1.0	DATE MAY15/23

10.3 Pivot Top Shield:

Pivot top EMI shield about hook, until seated in final position. Ensure that front flanges engage with grooves in both bottom EMI shield & insulator.

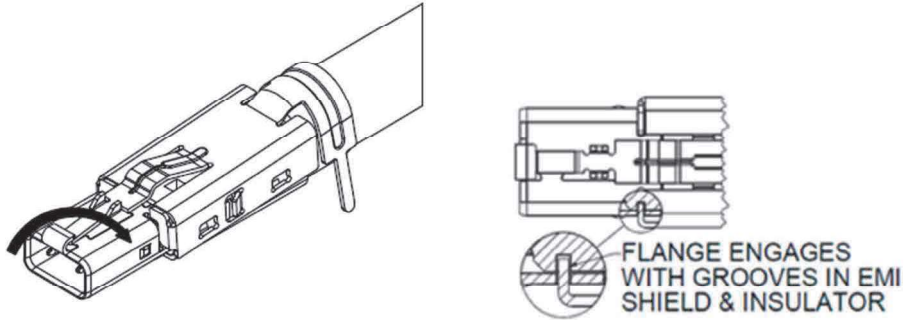

10.4 Top Shield Bending:

Press top EMI shield down to finish assembly. Ensure that side latches engage (2 per side, 4 in total).

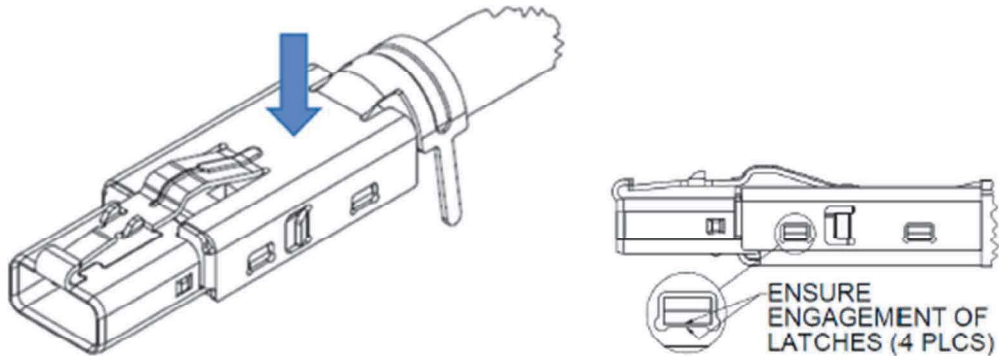

NUMBER <b>S6232C</b>	CATEGORY <b>Application Specification</b>	<b>Amphenol</b> COMMUNICATIONS SOLUTIONS	 <b>Commercial Industrial</b>
TITLE <b>MSPE PLUG IDC TERMINATION</b>		REVISION 1.0	DATE MAY15/23

### 10.5 Crimp Shield:

Prepare hand-crimp tool with appropriate die set for the respected cable diameter being crimped. Insert the connector into the crimping interface of the hand tool, ensuring that connector is pushed completely forward, hitting stopping surface of hand tool. The crimp barrel should be sitting directly on the crimp profile. Press the hand tool handles together until crimping shield fingers are completely wrapped around cable. To open tool and remove insert assembly, continue to squeeze until the ratchet releases and allows the tool to open.

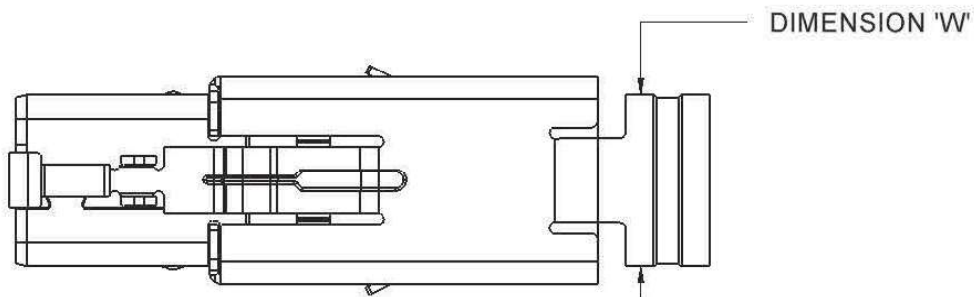

Inspect crimp quality. Repeat above steps if necessary. Crimped barrel dimensions will vary based on cable being used. Dimension 'W' may range from 3.5mm to 6.5mm. Recommended crimp strength in cable axial direction: 60N or above

NUMBER <b>S6232C</b>	CATEGORY <b>Application Specification</b>	<b>Amphenol</b> COMMUNICATIONS SOLUTIONS	 <b>Commercial Industrial</b>
TITLE <b>MSPE PLUG IDC TERMINATION</b>		REVISION 1.0	DATE MAY15/23

## 11. Final Assembly

### 11.1 Assemble Housing:

Assemble crimped shield sub-assembly into housing. Apply force to front face of EMI shield. Ensure engagement of EMI shield tabs with cutouts in housing on both sides.

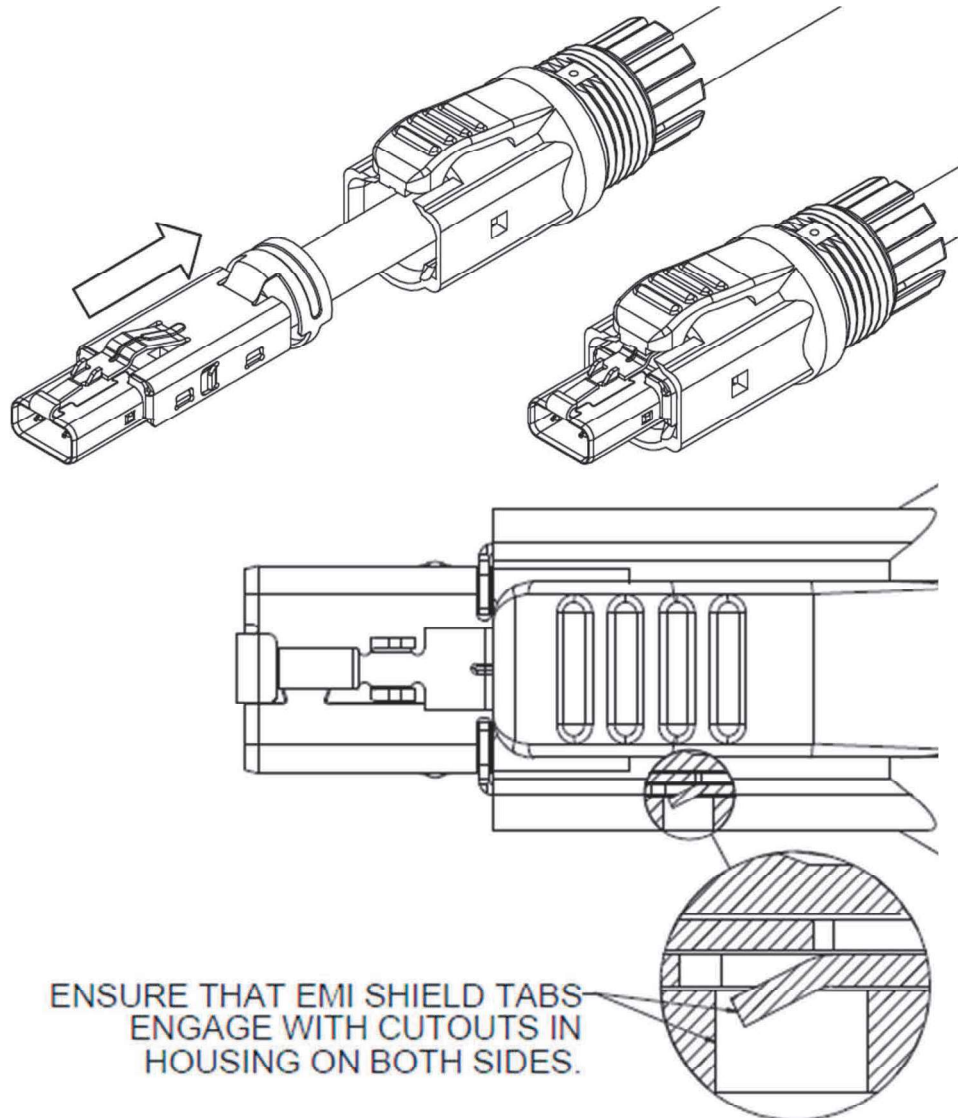

NUMBER <b>S6232C</b>	CATEGORY <b>Application Specification</b>	<b>Amphenol</b> COMMUNICATIONS SOLUTIONS	 <b>Commercial Industrial</b>
TITLE <b>MSPE PLUG IDC TERMINATION</b>		REVISION 1.0	DATE MAY15/23

### 11.2 Assemble Grommet:

Slide grommet, when applicable, along cable length and seat to full depth under tines of housing. Ensure to seat grommet to full depth against internal shoulder. Ensure that grommet is not twisted or pinched after assembly. See drawing P-MSPE-P2L0-XX0XX for appropriate grommet selection.

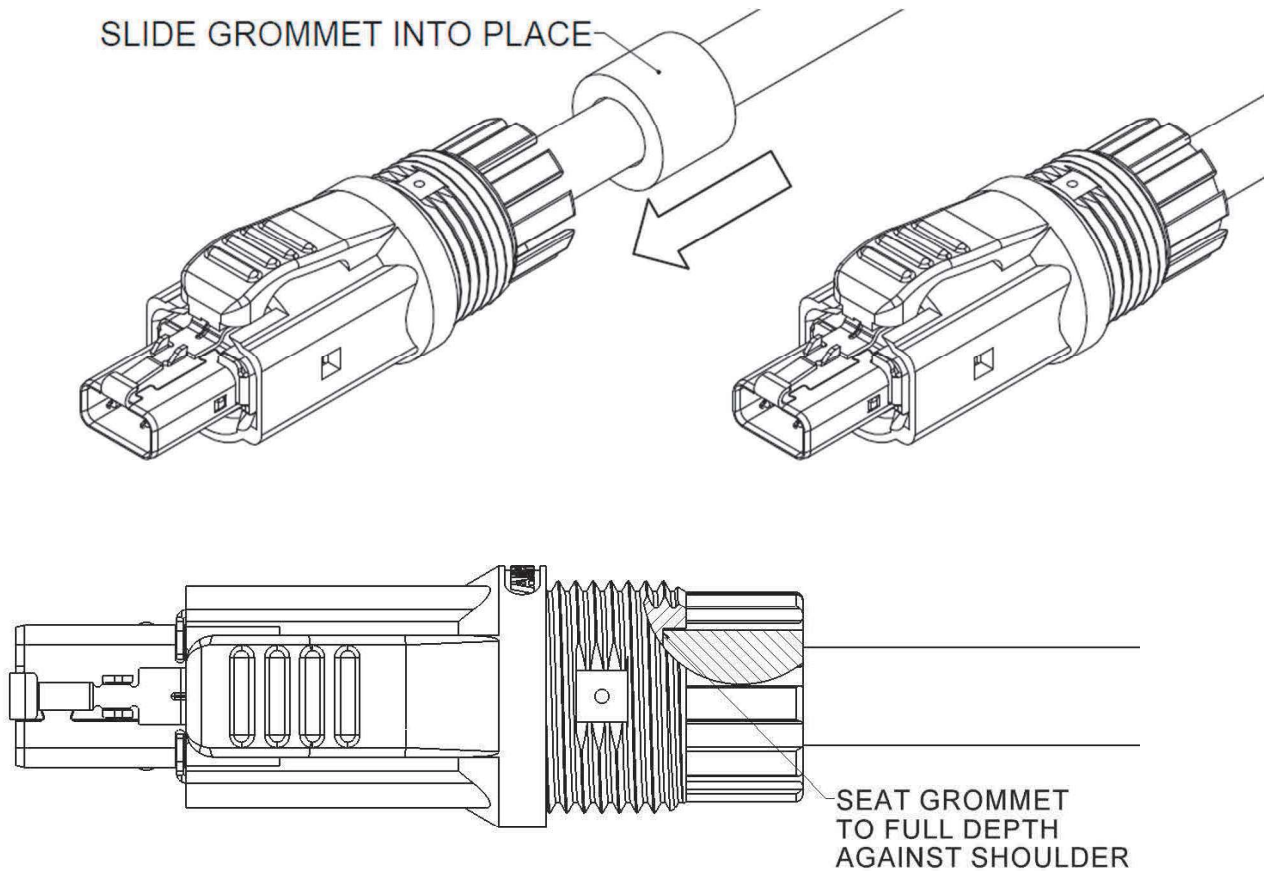

NUMBER <b>S6232C</b>	CATEGORY <b>Application Specification</b>	<b>Amphenol</b> COMMUNICATIONS SOLUTIONS	 <b>Commercial Industrial</b>
TITLE <b>MSPE PLUG IDC TERMINATION</b>		REVISION 1.0	DATE MAY15/23

### 11.3 Assemble Screw Cap:

Slide screw cap along cable length until in contact with housing. Screw on the cap, collapsing tines inwards, until hand tight. Recommended torque: 11.3dN-m [10 in-lbs].

