

# AKD<sup>®</sup>2G-Sxx with Functional Safety Option 1

## STO - SIL2

### Installation Manual, English



Manual Edition: F, June, 2023  
Safety Edition: S103, March 2023  
Valid for AKD<sup>®</sup>2G-S Hardware Revision A  
Part Number 907-200003-00

Original Document



For safe and proper use, follow these instructions. Keep for future use.



## Record of Document Revisions

Edition	Remarks
...	Table with lifecycle information of this document (→ # 202)
B, 04/2020	Electrical data updated, UL markings updated, default setting: STO active, connector tightening torque added to connector pin assignments, regen resistor wiring updated, AXIS#.ZEROx keywords updated for stop diagrams, X1/X2 feedback voltage 11V, X23 max. current 350mA, FS trouble shooting updated, SFA voltage/current values, continuous brake power of external regen resistor reduced, CE: external EMC mains filters for 7V models, max. cable length for unshielded I/O lines, 24V supply with X10T, SFF=75%, PROFINET added, EtherNet/IP added, X22 digital feedbacks added, breakers for 7V models removed
C, 07/2020	Performance data table corrected, mounting M/P values synchronized, X23/X41 pinout Step/Dir&CW/CCW updated, chapter CAN termination improved, PROFINET/EtherNet-IP label CHx->Portx, UL Markings updated, Modbus added
D, 05/2021	SFA shielding, Low Voltage DC Operation note, display screens updated, device front view updated, PROFINET certified, regen resistor fusing: FPS removed, SSI feedbacks on X22/X23 added
E, 07/2022	SD Card text updated, Letter of Volatility link added, chapter "Shielding on drive" improved, Incr. Encoder feedback on X21 added, BiSS-C and SSI feedbacks on X41 (SFA) added, new motor connector image, chapter "Motion Bus interface" updated, PROFINET certified and available, chapter "Gearing" restructured, chapter "Feedback connector" restructured, SCCR rating for MV breaker changed, EtherNet/IP table updated, chapter "Mechanical Installation": Texts restructured and dimension table adapted, chapter "Mains supply": semi-conductor added, fusing chapter restructured, EAC approval removed, max. cable length per feedback type added, X23 feedback connector graphic expanded, conformity with UK added
F, 06/2023	7V24S drive contents added, including updated cover image, connector position image, general wiring diagrams, specifications and data, X3A and X3B connector content, X4 and X5 content, individual X23 / X41 feedback wiring diagrams and specifications added, added connection to various mains supply network pages, addition to part number scheme, corrected table formatting, added connector options availability table.

## Hardware Revision (HR)

AKD2G	Firmware	WorkBench	KAS IDE	Remarks
A	from 02-00-00-000	from 2.00.0.0000	from 3.01	First revision

## Trademarks

- Regal Rexnord and Kollmorgen are trademarks of Regal Rexnord Corporation or one of its affiliated companies.
- AKD is a registered trademark of Kollmorgen Corporation.
- SafeMotion is a registered trademark of Kollmorgen Corporation.
- SMM is a registered trademark of Kollmorgen Corporation.
- EnDat is a registered trademark of Dr. Johannes Heidenhain GmbH.
- EtherCAT® is a registered trademark and patented technology, licensed by Beckhoff Automation GmbH, Germany.
- EtherNet/IP is a registered trademark of ODVA, Inc.
- MODBUS is a registered trademark of SCHNEIDER ELECTRIC USA, INC..
- HIPERFACE is a registered trademark of Max Stegmann GmbH.
- PROFINET is a registered trademark of PROFIBUS and PROFINET International (PI).
- Windows is a registered trademark of Microsoft Corporation.

## Current patents

- US Patent 2017/0211640 (method and apparatus for power saving, fail-safe control of an electromechanical brake), patent pending
- US Patent 16,247,478 (method and apparatus for limiting the output voltages of switching mode power supplies), patent pending
- US Patent 8,154,228 (Dynamic Braking For Electric Motors)
- US Patent 8,214,063 (Auto-tune of a Control System Based on Frequency Response)
- US Patent 10.374.468 (System and method for improved DC power line communication)

Patents referring to fieldbus functions are listed in the matching fieldbus manual.



**Technical changes which improve the performance of the device may be made without prior notice!**

This document is the intellectual property of Kollmorgen. All rights reserved. No part of this work may be reproduced in any form (by photocopying, microfilm or any other method) or stored, processed, copied or distributed by electronic means without the written permission of Kollmorgen.

# 1 Table of Contents

<b>1</b>	<b>Table of Contents</b>	<b>4</b>
<b>2</b>	<b>General</b>	<b>10</b>
2.1	About this Installation Manual	11
2.2	Using the PDF Format	11
2.3	Symbols Used	12
2.4	Abbreviations Used	13
<b>3</b>	<b>Product Safety</b>	<b>14</b>
3.1	You should pay attention to this	15
3.2	Use as Directed	17
3.3	Prohibited Use	18
3.4	Warning note labels	18
3.4.1	Notes placed on the product	18
3.4.2	Adhesive label in the package	18
3.5	Shock-hazard Protection	19
3.5.1	Leakage current	19
3.5.2	Residual current protective device (RCD)	19
3.5.3	Isolating transformers	19
3.6	Stop / Emergency Stop / Emergency Off	20
3.6.1	Stop	20
3.6.2	Emergency Stop	21
3.6.3	Emergency Off	21
<b>4</b>	<b>Product life cycle handling</b>	<b>22</b>
4.1	Transport	23
4.2	Packaging	23
4.3	Storage	23
4.4	Installation, setup and normal operation	23
4.5	Decommissioning	24
4.5.1	Volatile and non-volatile memory	24
4.6	Maintenance and cleaning	24
4.7	Disassembly	24
4.8	System Repair	25
4.9	Disposal	25
<b>5</b>	<b>Package</b>	<b>26</b>
5.1	Package Supplied	27
5.2	Nameplate	27
5.3	Part Number Scheme	28
5.3.0.1	Connector Options Availability	29
<b>6</b>	<b>Technical description and data</b>	<b>30</b>
6.1	The AKD2G Family of Digital Drives	31
6.2	Ambient Conditions, Ventilation and Mounting Position	33
6.3	Mechanical Data	34
6.4	Performance Data	34
6.5	Electrical data	35
6.5.1	Single axis variants (S)	35
6.5.1.1	Mains supply data, 1 phase AC, type AKD2G-Sxx- (S)	35
6.5.1.2	Mains supply data, 3 phase AC, type AKD2G-Sxx- (S)	35
6.5.1.3	Mains supply data, DC, type AKD2G-Sxx- (S)	35
6.5.1.4	Output data, type AKD2G-Sxx- (S)	36
6.5.2	Dual axis variants (D: I1=I2)	37
6.5.2.1	Mains supply data, 1 phase AC, type AKD2G-Sxx- (D)	37
6.5.2.2	Mains supply data, 3 phase AC, type AKD2G-Sxx- (D)	37

6.5.2.3	Mains supply data, DC, type AKD2G-Sxx- (D)	37
6.5.2.4	Output data, type AKD2G-Sxx- (D)	38
6.5.3	Steady State Control Current per Brake Option	39
6.6	Electrical Motor Braking	40
6.6.1	Drive dynamic braking	40
6.6.2	Regeneration braking	40
6.6.2.1	Functional description	40
6.6.2.2	Technical data for AKD2G-Sxx-6V	41
6.6.2.3	Technical data for AKD2G-Sxx-7V	42
6.7	LCD Display and Push-buttons (B1, B2)	43
6.8	SD Card Slot	46
<b>7</b>	<b>Mechanical Installation</b>	<b>47</b>
7.1	Important Notes	48
7.2	Guide to Mechanical Installation	48
7.3	Dimensions	49
<b>8</b>	<b>Electrical Installation</b>	<b>51</b>
8.1	Important Notes	52
8.2	Guide to electrical installation	53
8.3	Wiring	54
8.3.1	General	54
8.3.2	Mating connectors	54
8.3.3	Cable and Wire Requirements	55
8.3.3.1	Cable material	55
8.3.3.2	Cable length	55
8.3.3.3	T-Connector wiring	55
8.3.3.4	Cable cross sections and requirements	56
8.3.4	Protective Earth Connection	57
8.4	EMI Noise Reduction	58
8.4.1	Reducing EMI noise	58
8.4.2	Shielding with external shielding busbar	59
8.4.2.1	Shielding Concept	59
8.4.2.2	Shielding Busbar	60
8.4.3	Shielding connection to the drive	61
8.4.3.1	Shielding Concept	61
8.4.3.2	Grounding plates and shield connection clamps	62
8.4.3.3	Motor connector X1/X2 with shielding connection	62
8.5	Connection Overview	63
8.5.1	Connector Position AKD2G-Sxx-6V	63
8.5.2	Connector Position AKD2G-Sxx-7V	64
8.5.2.1	AKD2G 480 Vac, 24 Amp drive	65
8.5.3	Wiring overview, single axis drive	66
AKD2G Sxx-xxS 3-12 Amp Drives		66
AKD2G Sxx-724S 24 Amp Drives		67
8.5.4	Wiring overview, dual axis drive	68
AKD2G Sxx-xxS 3-12 Amp Drives		68
8.5.5	Connector pinout	69
8.5.5.1	X1 and X2: Motor, Brake, Feedback 1	69
8.5.5.2	X3: Mains, regen resistor, DC-Bus	70
8.5.5.3	X3A/X3B: Mains, regen resistor, DC-Bus	71
8.5.5.4	X4: Second Brake	72
8.5.5.5	X5: Feedback 2	72
8.5.5.6	X10: 24 VDC	72
8.5.5.7	X11, X12: EtherNet Fieldbus	73
8.5.5.8	X13, X14: CAN bus (optional)	73

---

8.5.5.9 X20: Service .....	73
8.5.5.10 X21: I/O, Feedback 4 .....	74
8.5.5.11 X22: I/O, EEO2, Feedback 5 .....	75
8.5.5.12 X23: I/O, EEO1, Feedback 3 .....	76
8.5.5.13 X41: SFA Feedback converter, EEO3/EEO4 EXX3/EXX4 (accessory) .....	77
8.6 Power and Logic Voltage Supply (X3/X10) .....	78
8.6.1 Electrical Supply Connection .....	78
8.6.1.1 Connection to various mains supply networks AKD2G-Sxx-6V (100V to 240V) .....	78
8.6.1.2 Connection to various mains supply networks AKD2G-Sxx-7V (240V to 480V) .....	79
8.6.2 Mains power supply connector X3/X3A .....	80
8.6.2.1 Wiring examples mains power supply .....	81
8.6.2.2 Fusing .....	85
8.6.3 Auxiliary voltage power supply connector X10 .....	91
8.6.3.1 Fusing .....	91
8.6.3.2 Wiring example 24 VDC supply .....	91
8.7 DC Bus link connector X3/X3B .....	92
8.7.1 Fusing .....	93
8.7.2 Wiring example with T connectors .....	93
8.7.3 Wiring example with busbar .....	94
8.8 Regen resistor connector X3/X3B .....	95
8.8.1 Fusing and Wiring .....	95
8.9 Motor Power, Brake and Feedback connection .....	96
8.9.1 Motor connectivity, some examples .....	96
8.9.2 Single motor cable connection .....	97
8.9.2.1 Motor Power, Brake and Feedback connectors X1, X2 .....	97
8.9.2.2 Feedback connectors X21, X22, X23 .....	98
8.9.2.3 Secondary Brake connector X4 .....	98
8.9.3 Dual motor cable connection .....	99
8.9.3.1 Motor power and motor brake connectors X1, X2 .....	100
8.9.3.2 Feedback connectors X1, X2, X5, X41, X21, X22, X23 .....	100
8.9.3.3 7V24S Model Secondary Brake connector X4 .....	100
8.9.4 Motor Holding Brake Connection .....	101
8.9.4.1 Secondary Brake connector X4 .....	103
8.10 Feedback Connection .....	104
8.10.1 Overview .....	104
8.10.2 Feedback to Connector .....	104
8.10.3 Feedback Type to Connector .....	105
8.10.4 Maximum Cable Lengths by Feedback Type .....	105
8.10.5 Feedback Connectors X1, X2 .....	106
8.10.6 Feedback Connector X5 .....	107
8.10.7 Feedback Connector X21 .....	108
8.10.8 Feedback Connector X22 .....	109
8.10.9 Feedback Connector X23 .....	110
8.10.9.1 X23 Connector Pinout Summary .....	110
8.10.10 X23 Feedback Wiring Pinout Diagrams .....	112
8.10.10.1 X23 SFD Feedback .....	112
8.10.10.2 X23 Resolver Feedback .....	113
8.10.10.3 X23 BiSS (Mode B) Analog Feedback .....	114
8.10.10.4 X23 BiSS (Mode C) Digital Feedback .....	115
8.10.10.5 X23 EnDAT 2.1 Feedback (with 1V p-p analog signals) .....	116
8.10.10.6 X23 EnDAT 2.2 Digital Feedback .....	117
8.10.10.7 X23 HIPERFACE Feedback .....	118
8.10.10.8 X23 Sine Encoder Feedback .....	119
8.10.10.9 X23 Sine Encoder with Hall Feedback .....	120



8.10.10.10	X23 Incremental Encoder Feedback .....	121
8.10.10.11	X23 Incremental Encoder with Hall Feedback .....	122
8.10.10.12	X23 Hall Feedback .....	123
8.10.10.13	X23 SSI Feedback .....	123
8.10.10.14	X23 Step / Direction and CW / CCW Feedback .....	124
8.10.11	Feedback Connector X41 (SFA, accessory) .....	125
8.10.11.1	X41 Connector Pinout Summary .....	126
8.10.12	X41 Feedback Wiring Pinout Diagrams .....	127
8.10.12.1	X41 SFD Feedback .....	127
8.10.12.2	X41 Resolver Feedback .....	128
8.10.12.3	X41 BiSS (Mode B) Analog Feedback .....	129
8.10.12.4	X41 BiSS (Mode C) Digital Feedback .....	130
8.10.12.5	X41 EnDAT 2.1 Feedback (with 1 V p-p analog signals) .....	131
8.10.12.6	X41 EnDAT 2.2 Digital Feedback .....	132
8.10.12.7	X41 HIPERFACE Feedback .....	133
8.10.12.8	X41 Sine Encoder Feedback .....	134
8.10.12.9	X41 Sine Encoder with Hall Feedback .....	135
8.10.12.10	X41 Incremental Encoder Feedback .....	136
8.10.12.11	X41 Incremental Encoder with Hall Feedback .....	137
8.10.12.12	X41 Hall Feedback .....	138
8.10.12.13	X41 SSI Feedback .....	138
8.11	Gearing .....	139
8.11.1	Overview .....	139
8.11.2	Input - Electronic Gearing .....	139
8.11.3	Output - Emulated Encoder Output (EEO) .....	139
8.11.4	Master-Slave control .....	141
8.11.4.1	Examples .....	141
8.12	Ethernet Fieldbus Interface Connector X11/X12 .....	142
8.12.1	EtherCAT® .....	142
8.12.2	PROFINET .....	143
8.12.3	EtherNet/IP .....	144
8.13	CAN-Bus Interface connector X13/X14 .....	145
8.13.1	CAN-Bus Topology .....	145
8.13.2	CAN-Bus Wiring .....	146
8.13.3	Baud rate for CAN-Bus .....	147
8.13.4	Node Address for CAN-Bus .....	147
8.13.5	CAN-Bus Termination .....	147
8.14	Service Interface connector X20 .....	148
8.14.1	Possible Network Configurations .....	148
8.15	Modbus TCP connector X20 .....	149
8.16	I/O Connectors X21/X22/X23 .....	150
8.16.1	Technical data .....	151
8.16.2	Analog Input .....	152
8.16.3	Analog Output .....	153
8.16.4	Digital Inputs .....	154
8.16.4.1	Digital-In 1 and 2 .....	154
8.16.4.2	Digital-In 3 to 12 .....	155
8.16.4.3	Digital-In/Out 1 and 2 .....	156
8.16.4.4	Digital-In/Out 3 to 6 .....	157
8.16.5	Digital Outputs .....	158
8.16.5.1	Digital-Out 1 to 6 .....	158
8.16.5.2	Digital-Out 7 and 8 .....	159
8.16.5.3	Digital-In/Out 1 and 2 .....	160
8.16.5.4	Digital-In/Out 3 to 6 .....	160

8.16.5.5	Digital-Out 9, Relay contacts	161
<b>9</b>	<b>Setup</b>	<b>162</b>
9.1	Important Notes	163
9.2	Guide to drive setup	164
9.2.1	Initial Drive Test Procedure	164
9.2.1.1	Unpacking, mounting, and wiring the AKD2G	164
9.2.1.2	Minimum wiring for drive test without load, example	164
9.2.1.3	Confirm connections (example: directly to PC)	165
9.2.1.4	System integration	165
9.2.1.5	Install and start WorkBench	165
9.2.1.6	Setup the axis in WorkBench	165
9.2.1.7	Enable the axis (Hardware)	166
9.2.1.8	Move the motor axis	166
9.2.1.9	Tune the axis	166
9.2.2	WorkBench Installation	167
9.2.2.1	Use as directed	167
9.2.2.2	Software description	168
9.2.2.3	Hardware requirements	168
9.2.2.4	Operating systems	168
9.2.2.5	Installation under Windows 7/8/10	169
9.3	Switch-On and Switch-Off Behavior	170
9.3.1	Switch-on behavior in standard operation	171
9.3.2	Switch-off behavior	172
9.3.2.1	Switch-off behavior using the AXIS#.DIS command	172
9.3.2.2	Switch-off behavior using a digital input (controlled stop)	173
9.3.2.3	Switch-off behavior using STO input (uncontrolled stop)	173
9.3.2.4	Switch-off behavior in the event of a fault	174
9.4	Fault and Warning Messages	177
9.4.1	Fault and warning messages AKD2G	177
9.5	Troubleshooting	178
<b>10</b>	<b>Safety Manual for FS1</b>	<b>179</b>
10.1	General Notes	180
10.1.1	Use as directed	181
10.1.2	Prohibited use	181
10.1.3	Abbreviations used for functional safety	181
10.1.4	Enclosure, wiring	182
10.2	Verification	183
10.3	Safety Function Option 1 (I/O, SIL2 PLd)	183
10.3.1	Safety Properties Overview	183
10.3.2	Technical Data	184
10.3.3	STO (Safe Torque Off)	185
10.3.3.1	Important Notes	185
10.3.3.2	Activation	185
10.3.3.3	Restart	186
10.3.3.4	Timing	187
10.3.3.5	Safety Diagnostic view in WorkBench	187
10.3.3.6	Fault Reaction / Failure Messages	188
10.4	Settings	189
10.5	Safety Faults, Safety Warnings	190
10.5.1	LCD Display	190
10.5.2	Drive Safety Faults	191
10.5.3	Safety Warnings	191
10.5.4	Troubleshooting Functional Safety	191
10.6	Functional Safety Parameter Reference	192

10.6.1 Safety Parameters, sorted alphanumeric .....	193
10.6.1.1 AXIS#.SAFE.STO.A .....	193
10.6.1.2 AXIS#.SAFE.STO.B .....	193
10.6.1.3 AXIS#.SAFE.STO.ACTIVE .....	194
10.6.1.4 AXIS#.SAFE.STO.REPORTFAULT .....	194
<b>11 Approvals .....</b>	<b>195</b>
11.1 Conformance with UL/cUL .....	196
11.1.1 3-12 A drives .....	196
11.1.2 7V24S 24 A drives .....	197
11.2 Conformance with EU .....	198
11.2.1 Functional Safety .....	199
11.2.2 Conformance with RoHS .....	199
11.2.3 Conformance with REACH .....	199
11.2.4 Waste Framework Directive Substances of Concern in Products (SCIP) Database .....	199
11.3 Conformance with UK .....	199
<b>12 Index .....</b>	<b>200</b>
<b>13 Record of document revisions .....</b>	<b>202</b>
<b>14 Requirements to User Documentation, Revision 1.12 .....</b>	<b>205</b>
14.1 SDRS/SSRS .....	205
14.2 IEC 61508-2 Annex D Requirements to User Documentation .....	208
14.3 ISO 13849-1, clause 11, Requirements to User Documentation .....	209
14.4 IEC 61508-3 Annex D Requirements to User Documentation .....	210
14.5 Revisions .....	210

## 2 General

---

<b>2.1 About this Installation Manual</b> .....	<b>11</b>
<b>2.2 Using the PDF Format</b> .....	<b>11</b>
<b>2.3 Symbols Used</b> .....	<b>12</b>
<b>2.4 Abbreviations Used</b> .....	<b>13</b>



## 2.1 About this Installation Manual

This document, the *AKD<sup>®</sup>2G Installation Manual* ("Instructions Manual" according to EC Machinery Directive 2006/42/EU), describes the AKD<sup>®</sup>2G series of digital drives and includes information needed to safely install an AKD2G.

This document is valid for AKD2G single axis drive or dual axis drive with 110 V to 240 V or 240 V to 480 V mains voltage.

- Output stages: 3 A or 6 A, 12 A or 24 A rated current
- Programmability options: Base drive or Position Indexer drive
- Connectivity options: analog, CANopen, EtherCAT, PROFINET, EtherNet/IP
- I/O options: Extended I/O (X22), Feedback&EEO (X23)
- Functional Safety Option: FS1 with STO; SIL2 PLd

A digital version of this manual (.PDF format) is available on the DVD included with your drive.

AKD2G information for use consists of:

- *Safety Notes*: multi-language document with safety information, part of product delivery in Europe, printed on paper DIN A5.
- *Installation Manual*: This document, describes the AKD2G series of digital drives and includes information needed to safely install an AKD2G.
- *WorkBench Online Help*: describes how to use your drive in common applications. It also provides tips for maximizing your system performance with the AKD2G. The *Online Help* includes the *Parameter and Command Reference Guide* which provides information for the parameters and commands used to program the AKD2G.
- *CAN-BUS Communication*: describes how to use your drive in CANopen applications.
- *EtherCAT Communication*: describes how to use your drive in EtherCAT applications.
- *PROFINET Communication*: describes how to use your drive in PROFINET applications.
- *EtherNet/IP Communication*: describes how to use your drive in EtherNet/IP applications.
- *Accessories Manual*: provides information for accessories like cables and regen resistors used with AKD2G. Regional variants of this manual exist.

All documents can be downloaded from the Kollmorgen website [www.kollmorgen.com](http://www.kollmorgen.com).











## 2.2 Using the PDF Format

This document includes several features for ease of navigation













<b>Cross References</b>	Table of contents and index include active cross references.
<b>Table of contents and index</b>	Lines are active cross references. Click on the line and the appropriate page is accessed.
<b>Page/chapter numbers in the text</b>	Page/chapter numbers with cross references are active links.

## 2.3 Symbols Used

### Warning symbols

Symbol	Indication
	Indicates a hazardous situation which, if not avoided, will result in death or serious injury.
	Indicates a hazardous situation which, if not avoided, could result in death or serious injury.
	Indicates a hazardous situation which, if not avoided, could result in minor or moderate injury.
	Indicates situations which, if not avoided, could result in property damage.
	This symbol indicates important notes.
	High Noise Pollution. The type of danger is specified by the text next to the symbol.
	Warning of a danger (general). The type of danger is specified by the text next to the symbol.
	Warning of danger from electricity and its effects.
	Warning of danger from hot surface.
	Warning of danger from suspended loads.
	Warning of danger from automatic start.

### Drawing symbols

Symbol	Description	Symbol	Description
	Signal ground		Diode
	Chassis ground		Relay
	Protective earth		Relay switch off delayed
	Resistor		Normally open contact
	Fuse		Normally closed contact
	State-of-the-art firewall		EMC filter

## 2.4 Abbreviations Used

Abbreviations related to functional safety (→ # 181).

Abbreviation	Meaning
(→ # 53)	"see page 53" in this document
→ xyz	"see chapter xyz" in this document
$\Omega$	Ohms
A#, AXIS#	A# or AXIS# are placeholders for the axis number. Used with parameters or signal names
AGND	Analog ground
AquadB	In quadrature output, used for incremental encoder emulation
AMSL	Above mean sea level
Axis	Depends on context, either one AKD2G output stage or one load axis of the full motion system.
CAT	Category
CE	Communauté Européenne
COM	Serial interface for a personal computer
DGND	Digital ground
EEPROM	Electrically erasable programmable memory
EEO	Emulated Encoder Output
EMC	Electromagnetic compatibility
EMF	Electromagnetic force
FS1, FS2, FS3	Functional Safety Option 1, 2, 3
FSoE	Fail safe over EtherCAT
KAS	Kollmorgen Automation Suite
KAS IDE	Setup software (Kollmorgen Automation Suite Integrated Development Environment)
KDN	Kollmorgen Developer Network
LED	Light-emitting diode
LSB	Low significant byte (or bit)
MSB	Most significant byte (or bit)
NI	Zero pulse
OSSD	Output Signal Switching Device
PE	Protective earth
PELV	Protective Extra Low Voltage
PLC	Programmable logic control
PWM	Pulse-width modulation
RAM	Random access memory (volatile memory)
RBrake/RB	Regen resistor (also called a brake resistor)
RBext	External regen resistor
RBint	Internal regen resistor
RCD	Residual current device
RES	Resolver
S1	Continuous operation
tbd	To be determined (in process)
VAC	Volts, alternating current
VDC	Volts, direct current

## 3 Product Safety

---

<b>3.1 You should pay attention to this</b> .....	<b>15</b>
<b>3.2 Use as Directed</b> .....	<b>17</b>
<b>3.3 Prohibited Use</b> .....	<b>18</b>
<b>3.4 Warning note labels</b> .....	<b>18</b>
<b>3.5 Shock-hazard Protection</b> .....	<b>19</b>
<b>3.6 Stop / Emergency Stop / Emergency Off</b> .....	<b>20</b>



### 3.1 You should pay attention to this

This section helps to recognize risks and avoid dangers to people and objects.

#### Specialist staff required!

The devices are intended for industrial applications. Machine builders must employ qualified personnel. Qualified personnel are people who have been trained to transport, install, commission and operate electrical drives.

- Transport, storage, unpacking: only by personnel with knowledge of handling electrostatically sensitive components.
- Mechanical installation: only by personnel with mechanical expertise.
- Electrical installation: only by personnel with expertise in electrical engineering.
- Basic tests / setup: only by personnel with expertise in electrical engineering and drive technology.

The qualified personnel must know and observe ISO 12100 / IEC 60364 / IEC 60664 and national accident prevention regulations.

#### Read the documentation!

Read the available documentation before installation and commissioning. Improper handling of the devices can cause harm to people or damage to property. The operator of systems using the drive system must ensure that all personnel who work with the drive read and understand the manual before using the drive.

#### Check Hardware Revision!

Check the Hardware Revision Number of the product (see product label). This number is the link between your product and the manual. The product Hardware Revision Number must match the Hardware Revision Number on the cover page of the manual.

#### Pay attention to the technical data!

Adhere to the technical data and the specifications on connection conditions. If permissible voltage values or current values are exceeded, the devices can be damaged. Unsuitable motor or wrong wiring will damage the system components. Check the combination of drive and motor. Compare the rated voltage and current of the units.

#### Perform a risk assessment!

The manufacturer of the machine must generate a risk assessment for the machine, and take appropriate measures to ensure that unforeseen movements cannot cause injury or damage to any person or property. Additional requirements on specialist staff may also result from the risk assessment.

#### Automatic restart



The drive might restart automatically after power on, voltage dip or interruption of the supply voltage, depending on the parameter setting. Risk of death or serious injury for humans working in the machine.

If the parameter `AXIS#.ENDEFAULT` is set to 1, then place a warning sign to the machine (Warning: Automatic Restart at Power On) and ensure, that power on is not possible, while humans are in a dangerous zone of the machine. In case of using an undervoltage protection device, you must observe EN 60204-1:2006 chapter 7.5.

**ATTENTION:** The drive is ready to operate with pre-configured STO function.

**Observe electrostatically sensitive components!**

The devices contain electrostatically sensitive components which may be damaged by incorrect handling. Electrostatically discharge your body before touching the device. Avoid contact with highly insulating materials (artificial fabrics, plastic film etc.). Place the device on a conductive surface.

**Hot surface!**

Drives may have hot surfaces during operation. The housing can reach temperatures above 80°C. Risk of minor burns! Measure the temperature, and wait until the housing has cooled down below 40 °C before touching it.

**Earthing!**

It is vital that you ensure that the drive is safely earthed to the PE (protective earth) busbar in the switch cabinet. Risk of electric shock. Without low-resistance earthing no personal protection can be guaranteed.

**Leakage Current!**

Since the leakage current to PE is more than 3.5 mA, in compliance with IEC61800-5-1 the PE connection must either be doubled or a connecting cable with a cross-section >10 mm<sup>2</sup> must be used. Deviating measures according to regional standards might be possible.

**High voltages!**

The equipment produces high electric voltages up to 900 V. Lethal danger exists at live parts of the device. Do not open or touch the equipment during operation. Keep all covers and cabinet doors closed. Built-in protection measures such as insulation or shielding may not be removed. Work on the electrical installation may only be performed by trained and qualified personnel, in compliance with the regulations for safety at work, and only with switched off mains supply, and secured against restart.

Never undo any electrical connections to the drive while it is live. There is a danger of electrical arcing with damage to contacts and personal injury. Wait at least 5 minutes after disconnecting the drive from the main supply power before touching potentially live sections of the equipment (such as contacts) or removing any connections.

Always measure the voltage in the DC bus link and wait until the voltage is below 50 V before handling components.

**Functional Safety!**

The assessment of the safety functions according to EN13849 or EN 62061 must finally be done by the user.

**Reinforced Insulation**

Thermal sensors, motor holding brakes and feedback systems built into the connected motor must have reinforced insulation (according to IEC61800-5-1) against system components with power voltage, according to the required application test voltage. All Kollmorgen components meet these requirements.

**Never modify the drive!**

It is not allowed to modify the drive hardware without permission by the manufacturer. Opening the housing causes loss of warranty.

**High noise pollution!**

Fans generate noise of up to 76 dBA when operating at maximum load. This can lead to hearing damage. Keep the cabinet doors closed during operation. Use ear protection if the control cabinet has to be opened during servicing. The operator must provide ear protection and monitor its use depending on the daily noise exposure level determined.

## 3.2 Use as Directed

The AKD2G drives are exclusively intended for driving suitable synchronous servomotors with closed-loop control of torque, speed, and/or position.

AKD2G are components that are built into electrical plants or machines and can only be operated as integral components of these plants or machines. The manufacturer of the machine used with a drive must generate a risk assessment for the machine. When the drives are built into machines or plant, the drive must not be used until it has been established that the machine or plant fulfills the requirements of the regional directives.

### Cabinet and wiring

Drives must only be operated in a closed control cabinet suitable for the ambient conditions (→ # 33). Ventilation or cooling may be necessary to keep the temperature within the cabinet below 40 °C or 60 °C if using extended range operation with derating.

Only use copper conductors for wiring. The conductor cross-sections can be derived from the standard IEC 60204 (alternatively for AWG cross-sections: NEC Table 310-16, 75 °C column).

### Power supply

The drives can be supplied by 1, 2 or 3 phase (TN-S or TT) or DC industrial supply networks.

Drives in the AKD2G series can be supplied as follows:

- AKD2G-Sxx-6Vxx:  
1, 2 or 3 phase industrial supply networks (not more than 10 kA symmetrical rated current at 120 V and 240 V) or DC supply.
- AKD2G-Sxx-7Vxx:  
3 phase industrial supply networks (not more than 10 kA symmetrical rated current at 240 V, 400 V and 480 V) or DC supply.

Connection to other voltage types of supply networks is possible with an additional isolating transformer.

Repeated overvoltages between phases (L1, L2, L3) and the housing of the drive must not exceed 1000 V peak. In accordance with IEC 61800, voltage spikes (< 50 µs) between phases must not exceed 1000 V. Voltage spikes (< 50 µs) between a phase and the housing must not exceed 2000 V.

### Motor voltage rating

The rated voltage of the motors must be at least as high as the DC bus link voltage divided by  $\sqrt{2}$  produced by the drive ( $U_{nMotor} \geq U_{DC}/\sqrt{2}$ ).

### Functional Safety

#### NOTICE

- The network, to which the drive is connected, must be secured according to state-of-the-art information technology security requirements.
- The user IT specialists shall analyze whether further security requirements are applicable to ensure functional safety.

Review the chapter "Use as Directed" in the Functional Safety section before using safety functionality.

### 3.3 Prohibited Use

Other use than that described in chapter “Use as directed” is not intended and can lead to personnel injuries and equipment damage. The drive may not be used with a machine that does not comply with appropriate national directives or standards. The use of the drive in the following environments is also prohibited:

- potentially explosive areas
- environments with corrosive and/or electrically conductive acids, alkaline solutions, oils, vapors, dusts
- ships or offshore applications

#### **NOTICE**

The drive must not be connected directly to the Internet. If the network, to which the drive is connected, is not secured according to state-of-the-art information technology, this could be a functional safety risk.

### 3.4 Warning note labels

#### 3.4.1 Notes placed on the product



Wait 5 minutes  
after removing power  
before servicing.

#### 3.4.2 Adhesive label in the package

#### **NOTICE**

Follow the instructions given on the adhesive labels in the package.  
If a warning note label is damaged, it must be replaced immediately.



## 3.5 Shock-hazard Protection

### 3.5.1 Leakage current

Leakage current via the PE conductor results from the combination of equipment and cable leakage currents. The leakage current frequency pattern includes a number of frequencies, whereby the residual-current circuit breakers definitively evaluate the 50 Hz current. For this reason, the leakage current cannot be measured using a conventional multimeter. Contact our application department for help to calculate the leakage current in your application.

#### NOTE

Since the leakage current to PE is more than 3.5 mA, in compliance with IEC61800-5-1 the PE connection must either be doubled or a connecting cable with a cross-section  $>10 \text{ mm}^2$  must be used. Use the PE terminal and the PE connection screws in order to fulfill this requirement.

The following measures can be used to minimize leakage currents:

- Reduce the length of the engine cable.
- Use low capacitance motor cables (→ # 55).

### 3.5.2 Residual current protective device (RCD)

In conformity with IEC 60364-4-41 – Regulations for installation and IEC 60204 – Electrical equipment of machinery, residual current protective devices (RCDs) can be used provided the requisite regulations are complied with. The AKD2G is a 3-phase system with a B6 bridge. Therefore, RCDs which are sensitive to all currents must be used in order to detect any DC fault current.

Rated residual currents in the RCDs:

<b>10 to 30 mA</b>	Protection against "indirect contact" (personal fire protection) for stationary and mobile equipment, as well as for "direct contact".
<b>50 to 30 mA</b>	Protection against "indirect contact" (personal fire protection) for stationary equipment

#### NOTE

Recommendation: In order to protect against direct contact (with motor cables shorter than 5 m) Kollmorgen recommends that each drive be protected individually using a 30 mA RCD which is sensitive to all currents.

If you use a selective RCD, the more intelligent evaluation process will prevent spurious tripping of the RCD.

### 3.5.3 Isolating transformers

When protection against indirect contact is absolutely essential despite a higher leakage current, or when an alternative form of shock-hazard protection is sought, the AKD2G can also be operated by using an isolating transformer. A ground-leakage monitor can be used to monitor for short circuits.

#### NOTE

Keep the length of wiring between the transformer and the drive as short as possible.

### 3.6 Stop / Emergency Stop / Emergency Off

The control functions Stop, Emergency Stop and Emergency Off are defined by IEC 60204. Notes for functional safety aspects of these functions can be found in ISO 13849 and IEC 62061.

#### NOTE

The parameter `AXIS#.DISMODE` must be set to implement the different stop categories for software disabling. Consult the *WorkBench Online Help* for configuring the parameter.



#### **WARNING** Vertical load could fall!

Serious injury could result when the load is not properly blocked. The internal brake function does not ensure functional safety.

- Functional safety, e.g. with hanging load (vertical axes), requires an additional brake, controlled e.g. from the other axis or externally from a safety controller. The brakes can be mapped to an axis with WorkBench.
- The Hardware Enable does not initiate a controlled stop but switches off the power stage immediately.
- Set parameter `AXIS#.MOTOR.BRAKEIMM` to 1 with vertical axes, to apply the brake immediately after faults or Hardware Disable.
- Risk assessment of the application determines the necessary measures.

#### 3.6.1 Stop

The stop function shuts down the machine in normal operation. The stop function is defined by IEC 60204.

#### NOTE

The Stop Category must be determined by a risk evaluation of the machine.

Stop function must have priority over assigned start functions. The following stop categories are defined:

##### Stop Category 0

Shut-down by immediate switching-off the energy supply to the drive machinery (this is an uncontrolled shut-down). For stop without using safety functions like STO, set `AXIS#.DISMODE` to 0.

The safety function STO stops the drive as required by Stop Category 0 (IEC 62061).

##### Stop Category 1

A controlled shut-down, whereby the energy supply to the drive machinery is maintained to perform the shut-down, and the energy supply is only interrupted when the shut-down has been completed.

For stop without using safety functions like SS1, set `AXIS#.DISMODE` to 2.

The safety function SS1 stops the drive as required by Stop Category 1 (IEC 62061).

##### Stop Category 2

A controlled shut-down, whereby the energy supply to the drive machinery is maintained. This category shall be realized with a safety function like SS2. Safety function SS2 stops the drive as required by Stop Category 2 (IEC 62061).

Stop Category 0 and Stop Category 1 stops must be operable independently of the operating mode, whereby a Category 0 stop must have priority.

If necessary, provision must be made for the connection of protective devices and lock-outs. If applicable, the stop function must signal its status to the control logic. A reset of the stop function must not create a hazardous situation.

### 3.6.2 Emergency Stop

The Emergency Stop function is used for the fastest possible shutdown of the machine in a dangerous situation. The Emergency Stop function is defined by IEC 60204. Principles of emergency stop devices and functional aspects are defined in ISO 13850.

The Emergency Stop function will be triggered by the manual actions of a single person. It must be fully functional and available at all times. The user must understand instantly how to operate this mechanism (without consulting references or instructions).

**NOTE**

The Stop Category for the Emergency Stop must be determined by a risk evaluation of the machine.

In addition to the requirements for stop, the Emergency Stop must fulfill the following requirements:

- Emergency Stop must have priority over all other functions and controls in all operating modes.
- The energy supply to any drive machinery that could cause dangerous situations must be switched off as fast as possible, without causing any further hazards ( Stop Category 0) or must be controlled in such a way, that any movement that causes danger, is stopped as fast as possible (Stop Category 1).
- The reset must not initiate a restart.

### 3.6.3 Emergency Off

The Emergency Off function is used to switch-off the electrical power supply of the machine. This is done to prevent users from any risk from electrical energy (for example electrical impact). Functional aspects for Emergency Off are defined in IEC 60364-5-53.

The Emergency Off function will be triggered by the manual actions of a single person.

**NOTE**

The result of a risk evaluation of the machine determines the necessity for an Emergency Off function.

Emergency Off is done by switching off the supply energy by electro-mechanical switching devices. This results in a category 0 stop. If this stop category is not possible in the application, then the Emergency Off function must be replaced by other measures (for example by protection against direct touching).

## 4 Product life cycle handling

---

<b>4.1 Transport</b> .....	<b>23</b>
<b>4.2 Packaging</b> .....	<b>23</b>
<b>4.3 Storage</b> .....	<b>23</b>
<b>4.4 Installation, setup and normal operation</b> .....	<b>23</b>
<b>4.5 Decommissioning</b> .....	<b>24</b>
<b>4.6 Maintenance and cleaning</b> .....	<b>24</b>
<b>4.7 Disassembly</b> .....	<b>24</b>
<b>4.8 System Repair</b> .....	<b>25</b>
<b>4.9 Disposal</b> .....	<b>25</b>

## 4.1 Transport

Transport the AKD2G in accordance with IEC 61800-2 as follows:

- Transport only by qualified personnel in the manufacturer's original recyclable packaging.
- **NOTICE:** Avoid shocks while transporting.
- Vibration/Shock: AKD2G is tested for environmental class 2M1 of IEC 60721-3-2.
- Store at or below maximum stacking height 8 cartons (see "Storage" (→ # 23))
- Transport only within specified temperature ranges:  
-25 to +70 °C, max. rate of change 20 K/hour, class 2K3.
- Transport only within specified humidity:  
max. 95% relative humidity at +40°C, no condensation, class 2K3.

### NOTICE

The drives contain electrostatically sensitive components that can be damaged by incorrect handling. Electrostatically discharge yourself before touching the drive. Avoid contact with highly insulating materials, such as artificial fabrics and plastic films. Place the drive on a conductive surface.

If the packaging is damaged, check the unit for visible damage. Inform the shipper and the manufacturer of any damage to the package or product.

## 4.2 Packaging

The AKD2G packaging consists of recyclable cardboard with inserts and a label on the outside of the box.

Model	Package (mm) HxWxL	Total Weight (kg)
AKD2G-Sxx-6V03 to 6V12	158 x 394 x 292	4.2
AKD2G-Sxx-7V03 to 7V12	158 x 394 x 292	4.3
AKD2G-Sxx-7V24	158 x 394 x 292	7.6

### NOTE

Mating connectors are **not** included in the package of a standard drive.

Mating connectors are included when the drive is ordered with accessories (append "-A" to the model number).

## 4.3 Storage

Store the AKD2G in accordance with IEC 61800-2 as follows:

- Store only in the manufacturer's original recyclable packaging.
- Store at or below maximum stacking height 8 cartons.
- Store only within specified temperature ranges: -25 to +55 °C, max.rate of change 20 K/hour, class 1K4.
- Storage only within specified humidity: 5 to 95% relative humidity, no condensation, class 1K3.
- Store in accordance with the following duration requirements:
  - Less than 1 year: without restriction.
  - More than 1 year: capacitors must be re-formed before setting up and operating the drive. Re-forming procedures are described in the KDN ([Forming](#)).

## 4.4 Installation, setup and normal operation

Installation and setup information are given in this manual:

- Mechanical installation (→ # 47)
- Electrical installation (→ # 51)
- Setup (→ # 162)

Normal operation tested for environmental class 3K3 according to IEC 61800-2 (→ # 33).

The manufacturer of the machine defines the necessary end user expertise based on the risk assessment for the machine and describes the requirements for normal operation based on the application.

## 4.5 Decommissioning

### NOTICE

Only professional staff who are qualified in electrical engineering are allowed to decommission parts of the system.

### DANGER: Lethal Voltages!

There is a danger of serious personal injury or death by electrical shock or electrical arcing.

- Switch off the main switch of the switchgear cabinet.
- Secure the system against restarting.
- Block the main switch.
- Wait at least 5 minutes after disconnecting.

### 4.5.1 Volatile and non-volatile memory

[Letter of Volatility for AKD2G Drives](#): This letter of volatility describes volatile and non-volatile media as well as storage media on the AKD2G. Customers can use this document to comply with security requirements.

## 4.6 Maintenance and cleaning

The device does not require maintenance, it should be inspected once a year by professional staff.

### NOTICE

Do not immerse or spray the device. Avoid that liquid enters the device. The inside of the unit can only be cleaned by the manufacturer. Opening the device voids the warranty.

To clean the device exterior:

1. Decommission the device (see chapter 4.5 "Decommissioning").
2. Casing: Clean with Isopropanol or similar cleaning solution.

**Caution** : Highly Flammable! Risk of injury by explosion and fire.

- Observe the safety notes given on the cleaning liquid package.
  - Wait at least 30 minutes after cleaning before putting the device back into operation.
3. Protective grill on fan: Clean with a dry brush.

## 4.7 Disassembly

### NOTICE

Only professional staff who are qualified in electrical engineering are allowed to disassemble parts of the system.

1. Decommission the device (see chapter 4.5 "Decommissioning").
2. Check temperature.

**CAUTION**: High Temperature! Risk of minor burns. During operation, the heat sink of the drive may reach temperatures above 80 °C (176 °F). Before touching the device, check the temperature and wait until it has cooled below 40 °C (104 °F).

3. Remove the connectors. Disconnect the potential earth connection last.
4. Demount: loosen the fastening screws. Remove the device.

## 4.8 System Repair

### NOTICE

Only professional staff who are qualified in electrical engineering are allowed to exchange parts of the drive system.

**CAUTION:** Automatic Start! During replacement work a combination of hazards and multiple episodes may occur.

- Work on the electrical installation may only be performed by trained and qualified personnel, in compliance with the regulations for safety at work, and only with use of prescribed personal safety equipment.

### Exchange of the device

Only the manufacturer can repair the device. Opening the device voids the warranty.

1. Decommission the device (see chapter 4.5 "Decommissioning").
2. Demount the device (see chapter 4.7 "Disassembly").
3. Send the device to the manufacturer.
4. Install a new device as described in the Installation Manual.
5. Setup the system as described in the Installation Manual.

### Exchange of other drive system parts

If parts of the drive system ( for example cables) must be replaced, proceed as follows:

1. Decommission the device (see chapter 4.5 "Decommissioning").
2. Exchange the parts.
3. Check all connections for correct fastening.
4. Setup the system as described in the Installation Manual.

## 4.9 Disposal

### NOTICE

To dispose the unit properly, contact a certified electronic scrap disposal merchant.

In accordance with the WEEE-2012/19/EU guideline and similar, the manufacturer accepts returns of old devices and accessories for professional disposal. The sender needs to incur the transport costs.

Contact Kollmorgen and clarify the logistics.

Send the devices in the original packaging to the manufacturer address:

North America	South America
<b>KOLLMORGEN</b> 201 West Rock Road Radford, VA 24141, USA	<b>KOLLMORGEN</b> Avenida João Paulo Ablas, 2970 Jardim da Glória, Cotia – SP CEP 06711-250, Brazil
Europe	Asia
<b>KOLLMORGEN s.r.o</b> Evropská 864664 42 Modřice, Brno Czech Republic	<b>KOLLMORGEN</b> Room 302, Building 5, Lihpao Plaza, 88 Shenbin Road, Minhang District, Shanghai, China.

# 5 Package

---

<b>5.1 Package Supplied</b> .....	<b>27</b>
<b>5.2 Nameplate</b> .....	<b>27</b>
<b>5.3 Part Number Scheme</b> .....	<b>28</b>



## 5.1 Package Supplied

When a standard drive from the AKD2G series is delivered, the following items are included in the drive package:

- AKD2G
- Printed copy of *AKD<sup>®</sup>2G Safety Notes*
- DVD with WorkBench
- Panel safety label
- **ATTENTION:** Drive is ready to operate with pre-configured STO function.

### NOTE

Mating connectors are **not** included in the package of a standard drive.

Mating connectors are included when the drive is ordered with accessories (append “-A” to the model number).

Mating connectors listed below are never delivered with the drive. These mating connectors are usually part of the cables:

- Motor mating connector (X1, X2),
- SubD (X23, X41) for Feedback,
- RJ25 (X13, X14) for CAN Bus, and
- RJ45 (X11, X12, X20) for Service and EtherNet Fieldbus.

### Accessories sold separately

Accessories must be ordered separately if required, see regional Accessories Manual.

- EMC filters for mains supply voltage, categories C2 or C3
- External regen resistor
- Mating connector kits
- Motor mating connector
- Hybrid cable, assembled hybrid motor cables are available for all regions
- Motor cable, assembled motor cables are available for all regions
- Feedback cable, assembled feedback cables are available for all regions
- SFA (Smart Feedback Adapter)
- EtherNet service cable

## 5.2 Nameplate

A nameplate is attached to the side of the drive. The picture below is similar to the nameplate on the device.

<b>KOLLMORGEN</b> <sup>TM</sup>		Customer Support: North America: +1 (540) 633-3400 Europe: +49 (0) 2102-9394-0 Italy: +39 (0) 362-594260																					
201 W. Rock Road Radford, VA 24141																							
Model No: <b>AKD2G-SPE-6V06D-A1F3-0000</b>																							
Serial No: <b>R2-1900-00000 HW Rev: A</b>																							
MAC Address: <b>00-23-1B-00-00-00</b>																							
<table border="1"> <thead> <tr> <th colspan="3">Ratings at 40°C (See manual for ratings &gt;40°C)</th> </tr> <tr> <th></th> <th><i>INPUT</i></th> <th><i>OUTPUT</i></th> </tr> </thead> <tbody> <tr> <td>Voltage</td> <td>120/240 Vac</td> <td>0-240 Vac</td> </tr> <tr> <td>Frequency</td> <td>50/60 Hz</td> <td>0-599Hz</td> </tr> <tr> <td>Phase</td> <td>1 Ph/3 Ph</td> <td>3 Ph</td> </tr> <tr> <td>FL Current</td> <td>13/9.7 Arms</td> <td>6/6 Arms</td> </tr> <tr> <td>Power @ 240 Vac</td> <td>3.1/4.0 KVA</td> <td></td> </tr> </tbody> </table>			Ratings at 40°C (See manual for ratings >40°C)				<i>INPUT</i>	<i>OUTPUT</i>	Voltage	120/240 Vac	0-240 Vac	Frequency	50/60 Hz	0-599Hz	Phase	1 Ph/3 Ph	3 Ph	FL Current	13/9.7 Arms	6/6 Arms	Power @ 240 Vac	3.1/4.0 KVA	
Ratings at 40°C (See manual for ratings >40°C)																							
	<i>INPUT</i>	<i>OUTPUT</i>																					
Voltage	120/240 Vac	0-240 Vac																					
Frequency	50/60 Hz	0-599Hz																					
Phase	1 Ph/3 Ph	3 Ph																					
FL Current	13/9.7 Arms	6/6 Arms																					
Power @ 240 Vac	3.1/4.0 KVA																						
Enclosure Protection Rating: <b>IP20</b>																							
Before use, refer to CD for installation and safety information. Assembled in USA      www.kollmorgen.com      Patents, Patents Pending																							

### 5.3 Part Number Scheme

Use the part number scheme for product identification only.

Do not use it for the order process as not all features can always be combined among each other.

**NOTE**

- Mating connectors are **not** included in the package of a standard drive.
- Mating connectors are included when the drive is ordered with accessories (append “-A” to the model number).
- Mating connectors X1, X2, RJ25, RJ45, SubD are always part of the used cables.

#### AKD2G - S P E - 7V 06 S - A 1 F3 - 0000 - A

**Family**

AKD2G AKD 2nd generation

**Format**

S Servo IP20

**Drive Version**

P Position Indexer with motion tasks

**Connectivity Option**

- N Analog
- E EtherCAT®
- C CANopen®
- P PROFINET® IRT
- I Ethernet/IP™

**Voltage**

- 6V 120/240 V<sub>AC</sub> 1Ø/3Ø
- 7V 240/480 V<sub>AC</sub> 3Ø

**Current Rating**

- 03 3 A<sub>RMS</sub>
- 06 6 A<sub>RMS</sub>
- 12 12 A<sub>RMS</sub>
- 24 24 A<sub>RMS</sub>

**Options**

- S Single Axis
- D Dual Axis

**Connectors**

A with connectors (except X1/X2 and X23)

**Customization**

- 0000 Standard
- A000 Coated PCBs

**Connector Options\***

	Single Axis	Dual Axis
00	X4*, X5*, X21, X22 Standard	X21, X22 Standard
F3	+X23 (Feedback 3)	+X23 (Feedback 3)
IO	+X22 (I/O)	-
DX	X22 + X23	-

\*X4 & X5 are only available on 3, 6 and 12 Amp drives with FS2-3 and are standard on 24 Amp drives.

**Functional Safety (FS)**

- 1 STO, safe inputs (SIL2, PLd)

**Platform Revision**

- A MAP Revision A

**\*See connector options feedback, I/O, and brake availability on the following page.**

**Example AKD2G-SPE-7V06S-A1IO-0000**

AKD2G IP20 housing, position indexer, EtherCAT, 240 V to 480 V mains supply, 6 A rated current, single axis, Platform Revision A, dual channel STO SIL2 PLd, with additional I/O connector X22, uncoated, no mating connectors.

**Example AKD2G-SPE-6V03D-A1F3-A000-A**

AKD2G IP20 housing, position indexer, EtherCAT, 120 V to 240 V mains supply, 2 x 3 A rated current, dual axis, Platform Revision A, dual channel STO SIL2 PLd, with all possible connectors (X21 + X22 + X23), PCBs coated, with mating connectors.

### 5.3.0.1 Connector Options Availability

Connector Options – Feedback Availability	X1, X2 or X5 + SFA Cable ①							
	X1	X2	X5	X21	X22	X23	SFA-ROO	SFA-E00
HIPERFACE DSL	✓	✓	✓					
SFD						✓		✓
SFD3	✓	✓	✓					
Resolver						✓	✓	
BiSS B (Analog)/C (Digital)					C only	✓		✓
EnDAT 2.1(Analog)/2.2 (Digital)					2.2 only	✓		✓
HIPERFACE						✓		✓
Sin/Cos						✓		✓
Sin/Cos +Hall						✓		✓
Incr. Encoder				✓	✓	✓		✓
Incr. Encoder +Hall						✓		✓
Hall						✓		✓
SSI					✓	✓		✓
Step/Direction				✓	✓	✓		
CW/CCW				✓	✓	✓		

#### Connector Options – I/O Availability

	X21	X22	
Analog-In (AIN)	1 Differential input channel		
Analog-Out (AOUT)	1 Channel		
Digital-In (DIN)	8 Channels Total 2 IEEE EN61131-2 Standard, Fast, Differential Input Channels	4 IEEE EN61131-2 Standard Channels	
Digital-Out (DOUT)	1 channel (relay) + FS1 only 4 Standard DOUT	4 Channels – 2 Fast Channels (Volt Free)	
Digital In/Out (DIO)	-	2 RS-485/Single-Ended Channels	
Encoder Emulation Output ②	-	EEO2	
Electronic Gearing Input	✓	✓	
STO	FS1 Axis 1	FS1 Axis 2	
Safety In (SIN)	2 Channels, Slow – FS2, FS3 only	2 Channels, Slow – FS2 & FS3 only	
Safety Out (SOUT)	4 Channels Slow – FS2 & FS3 only	-	
	Digital In/Out (DIO)	Zero Pulse Available	Encoder Emulation Output②
X23	4 Channels Total		EEO1
SFA ① – X41 via X1	2 Differential/Single-ended input channels	✓	EEO3
SFA ① – X41 via X2 or X5	2 Single-ended input channels		EEO4

#### Connector Options – Secondary Brake Availability: X4 only

① The SFA (Smart Feedback Adapter) is optional and supplied separately.

② WorkBench configuration

## 6 Technical description and data

---

<b>6.1 The AKD2G Family of Digital Drives</b> .....	<b>31</b>
<b>6.2 Ambient Conditions, Ventilation and Mounting Position</b> .....	<b>33</b>
<b>6.3 Mechanical Data</b> .....	<b>34</b>
<b>6.4 Performance Data</b> .....	<b>34</b>
<b>6.5 Electrical data</b> .....	<b>35</b>
<b>6.6 Electrical Motor Braking</b> .....	<b>40</b>
<b>6.7 LCD Display and Push-buttons (B1, B2)</b> .....	<b>43</b>
<b>6.8 SD Card Slot</b> .....	<b>46</b>

## 6.1 The AKD2G Family of Digital Drives

### Available AKD2G-SP (Position Indexer) versions

Connectivity	Rated Voltages	Current	Axis	Rev	Funct. Safety
<b>N-</b> : Analog <b>C-</b> : CANopen <b>E-</b> : EtherCAT <b>P-</b> : PROFINET <b>I-</b> : EtherNet/IP	<b>6V</b> : 120/240VAC 1~ 240VAC 3~ 170/340 VDC <b>7V</b> : 240/400/480VAC 3~ 340/565/680 VDC	<b>03</b> : 3 A <b>06</b> : 6 A <b>12</b> : 12 A <b>24</b> : 24 A	<b>S-</b> : Single <b>D-</b> : Dual I1=I2	<b>A</b>	<b>1</b> : SIL2 STO

### Connector Options

Single Axis	Dual Axis
<b>00</b> : Basis (X21, 24 A model: +X4, +X5) <b>IO</b> : Basis +X22 <b>F3</b> : Basis +X23 <b>DX</b> : Basis +X22, +X23	<b>00</b> : Basis (X21, X22) <b>F3</b> : Basis +X23

### Standard features

- Single axis or dual axis in one housing
- Supply voltages:
  - DC
  - AC single phase, split phase, three phase AC neutral or leg grounded
  - Single or group supply, single or group mains fusing
- EtherNet Fieldbus on board, TCP/IP service channel and Modbus on board
- SFD3, HIPERFACE DSL motor feedback support on board
- Support for many conventional motor feedback types
- Step / Direction input on board
- Encoder emulation on board
- Use with synchronous servomotors, linear motors, and induction machines

### Power section

- Single or three phase AC supply, 5% to 110% of rated AC voltage over 47 to 63 Hz. Connection to higher AC voltage mains only by using isolating transformer.
- DC supply, voltage range 5% to 110% of rated DC voltage. Fusing to be provided by the user.
- Three phase bridge rectifier, integral soft-start circuit.
- DC bus link voltage can be connected in parallel for power sharing.
- Floating current sensors measure actual motor current
- Regenerative circuit with dynamic distribution of the generated power between several drives on the same DC bus link circuit.
- Internal regen resistor for all models, optional external regen resistor if required.

### Functional Safety Options

- FS1: STO; SIL2 PLd, command by I/O (→ # 183).

**Electrical safety**

- Appropriate insulation / creepage distances and electrical isolation for safe electrical separation, per IEC 61800-5-1, between the power input / motor connections and the signal electronics.
- Soft-start, over voltage detection, short-circuit protection, phase-loss detection.
- Temperature monitoring of the drive and motor.
- Electronic motor overload protection: foldback mechanism or optional fault response.

**Auxiliary supply voltage 24VDC**

- From an external, safety approved 24 V  $\pm$ 10% power supply (PELV).

**Parameter setting**

- WorkBench Software for setup by using TCP/IP.
- Download control parameter packages by using CoE

**Full digital control**

- Digital current loop (update 1.28  $\mu$ s / command 62.5  $\mu$ s)
- Digital velocity loop (update period 62.5  $\mu$ s)
- Digital position loop (update period 250  $\mu$ s)

**Inputs/Outputs (X21/X22/X23)**

- 2 programmable analog input ( $\rightarrow$  # 152)
- 2 programmable analog output ( $\rightarrow$  # 153)
- 12 programmable digital inputs ( $\rightarrow$  # 154)
- 8 programmable digital outputs ( $\rightarrow$  # 158)
- 6 programmable digital input/outputs ( $\rightarrow$  # 158)
- 4 safe STO inputs (dual channel STO per axis) ( $\rightarrow$  # 184)

**Connector Options**

- **IO**: X22 connector with additional digital inputs and outputs.
- **F3**: X23 connector for conventional motor feedbacks (Resolver, SFD, Tamagawa Smart Abs, Comcoder, 1Vp-p Sin-Cos encoders, incremental encoders, EnDAT 2.1/2.2 and HIPERFACE).
- **DX**: all possible connectors for extended I/O and feedback connections.

**Customization**

- 0000: uncoated PCBs, standard  
0xxx: uncoated PCBs, customized coding
- A000: coated PCBs, standard  
Axxx: coated PCBs, customized coding

**Connectivity**

- Feedback inputs ( $\rightarrow$  # 104)
- Encoder emulation output ( $\rightarrow$  # 139)
- Digital Inputs/Outputs ( $\rightarrow$  # 150)
- Service Interface ( $\rightarrow$  # 148)
- Modbus Interface ( $\rightarrow$  # 149)
- CANopen ( $\rightarrow$  # 145)
- EtherNet Fieldbus interface ( $\rightarrow$  # 142)

**Accessories**

- **SFA** (Smart Feedback Adapter) ( $\rightarrow$  # 125).
- Hybrid motor cables, motor power cables, motor feedback cables.
- External regen resistors.

For accessories refer to your regional *Accessories Manual*.

## 6.2 Ambient Conditions, Ventilation and Mounting Position

<b>Storage, Transport</b>	(→ # 23)
<b>Normal operation</b>	Environmental class 3K3 according to IEC 61800-2
<b>Surrounding temperature in operation</b>	<p>Internal regen resistor used:</p> <ul style="list-style-type: none"> <li>• 0 to +40 °C under rated conditions</li> <li>• +40 to +60 °C with output current derating 3 % per Kelvin</li> </ul> <p>Internal regen resistor not used:</p> <ul style="list-style-type: none"> <li>• 0 to +50 °C under rated conditions</li> <li>• +50 to +60 °C with output current derating 2 % per Kelvin</li> </ul>
<b>Humidity in operation</b>	Relative humidity 5 to 85%, no condensation, IEC 61800-2 class 3K3
<b>Site altitude</b>	<ul style="list-style-type: none"> <li>• Up to 1,000 m AMSL (above mean sea level): no restriction</li> <li>• 1,000 to 2,000 m AMSL: power derating 1.5%/100 m</li> <li>• Maximum altitude: 2,000 m AMSL</li> </ul>
<b>Pollution level</b>	Pollution level 2 as per IEC 60664-1
<b>Vibration</b>	Class 3M1 according to IEC 61800-2
<b>Shock</b>	Class L according to IEC 61800-2
<b>Drive protection</b>	IP 20 according to IEC 60529
<b>Drive EMC immunity</b>	Increased immunity according to EN 61800-5-2
<b>Mounting</b>	<p>Vertical position, in a cabinet with protection of at least IP 54</p> <p>Minimum cabinet size (WxHxD): 406 x 406 x 254 mm</p>
<b>Ventilation</b>	Built-in fan in all drive variants
<b>NOTICE</b>	The drive shuts down in case of excessively high temperature in the control cabinet. Make sure sufficient forced ventilation is supplied within the control cabinet.

### 6.3 Mechanical Data

		AKD2G-Sxx-				
	Unit	6V03S, 6V06S, 6V12S	6V03D, 6V06D	7V03S, 7V06S	7V03D, 7V06D, 7V12S	7V24S
Width	mm	76	76	75	75	100
Height, without connectors	mm	235	235	272	272	335
Height, with connectors	mm	303	303	340	340	450
Depth, without connectors	mm	221	221	221	221	274
Depth, with connectors	mm	232	232	232	232	291

**NOTE**

Dimension Drawing see section Mechanical Installation (→ # 47).

### 6.4 Performance Data

		AKD2G-Sxx-				
Performance Data	Units	6V03S/D 6V06S/D 6V12S	7V03S/D 7V06S	7V06D	7V12S	7V24S
High/Quiet PWM Switching Frequency (optional setting)(dynamic)	kHz	15.0	11.2	9.8	9.8	9.8
Nominal/High Load PWM Switching Frequency (dynamic)	kHz	10.3	8.1	6.5	5.9	6.5
High Load Stalled PWM Switching Frequency (dynamic)	kHz	5.1	4.1	3.3	2.9	3.3
Max. Voltage rise speed dU/dt	kV/μs	7.0	7.0	7.0	7.0	7.0
Current Loop Update Period	μs	1.28*	1.28*	1.28*	1.28*	1.28*
Velocity Loop Update Period	μs	62.5	62.5	62.5	62.5	62.5
Position Loop Update Period	μs	250	250	250	250	250
Max. Current Loop Bandwidth	Hz	3000	2400	1900	1700	1900
Max. Velocity Loop Bandwidth	Hz	750	650	600	550	600
Max. Position Loop Bandwidth	Hz	350	350	350	350	350
Max. Motor Electrical Frequency	Hz	599	599	599	599	599

\* Control updates every 1.28 μs. Current command is updated every 62.5 μs.



## 6.5 Electrical data

### 6.5.1 Single axis variants (S)

#### 6.5.1.1 Mains supply data, 1 phase AC, type AKD2G-Sxx- (S)

Input data	Units	6V03S	6V06S	6V12S
Operational supply voltage (line to line)	VAC	12 to 265		
Rated supply voltage	VAC	100 to 240		
Rated supply input frequency ( $\pm 5\%$ )	Hz	50 to 60		
Permitted switch on/off frequency	1/h	30		
Rated input VA at 240 V	kVA	1.0	1.7	3.1
Rated input current	A	4.0	7.1	13
Max. inrush current	A	10		
Rated DC bus link voltage	VDC	300		

#### 6.5.1.2 Mains supply data, 3 phase AC, type AKD2G-Sxx- (S)

Input data	Units	6V03S	6V06S	6V12S	7V03S	7V06S	7V12S	7V24S
Operational supply voltage (Line to Line)	VAC	12 to 265			24 to 525			
Rated supply voltage	VAC	100 to 240			200 to 480			
Rated supply input frequency ( $\pm 5\%$ )	Hz	50 to 60						
Permitted switch on/off frequency	1/h	30						
Rated input VA at 240 V (* at 480 V)	kVA	1.3	2.2	4.0	2.7*	4.4*	7.2*	15.2*
Rated input current	A	3.2	5.3	9.7	3.2	5.3	8.7	18.3
Max. inrush current	A	10						
Rated DC bus link voltage	VDC	140 to 340			280 to 680			

#### 6.5.1.3 Mains supply data, DC, type AKD2G-Sxx- (S)

Input data	Units	6V03S	6V06S	6V12S	7V03S	7V06S	7V12S	7V24S
Operational supply voltage (DC+ to DC-)	VDC	17 to 370			34 to 740			
Rated supply voltage	VDC	100 to 340			200 to 680			
Permitted switch on/off frequency	1/h	30						
Rated input power at 340 V (* at 680 V)	kW	0.62	1.25	2.5	1.25*	2.5*	5.0*	10*
Rated input current	A	2.0	4.0	8.0	2.0	4.0	8.0	16
Max. inrush current through AC input	A	10						
Rated DC bus link voltage	VDC	100 to 340			200 to 680			

## 6.5.1.4 Output data, type AKD2G-Sxx- (S)

	Units	6V03S	6V06S	6V12S	7V03S	7V06S	7V12S	7V24S	
<b>Continuous output current ( ± 3%)</b>	Arms	3	6	12	3	6	12	24	
<b>Peak output current (for 5s, ±3%)</b>	Arms	9	18	30	9	18	30	72	
Continuous motor shaft output power at rated input current									
at 1 x 120 VAC	kW	0.22	0.44	0.875	-	-	-	-	
at 1 x 240 VAC	kW	0.44	0.875	1.8	0.44	0.875	1.8	2.5	
at 3 x 120 VAC	kW	0.31	0.625	1.25	-	-	-	-	
at 3 x 240 VAC	kW	0.625	1.25	2.5	0.625	1.25	2.5	5.0	
at 3 x 400 VAC	kW	-	-	-	1.05	2.1	4.2	8.3	
at 3 x 480 VAC	kW	-	-	-	1.25	2.5	5.0	10.0	
at 170 VDC	kW	0.31	0.625	1.25	-	-	-	-	
at 340 VDC	kW	0.625	1.25	2.5	0.625	1.25	2.5	5.0	
at 565 VDC	kW	-	-	-	1.05	2.1	4.2	8.3	
at 680 VDC	kW	-	-	-	1.25	2.5	5.0	10.0	
Peak output power (for 1 s)									
at 1 x 120 VAC	kW	1.1	2.1	4.1	-	-	-	-	
at 1 x 240 VAC	kW	2.1	4.2	6.3	-	-	-	12	
at 3 x 120 VAC	kW	1.5	3	4.5	-	-	-	-	
at 3 x 240 VAC	kW	3.0	6.0	9.0	3.0	6.0	10	24	
at 3 x 400 VAC	kW	-	-	-	5.0	10	16.5	40	
at 3 x 480 VAC	kW	-	-	-	6.0	12	20	48	
at 170 VDC	kW	1.5	3	4.5	-	-	-	-	
at 340 VDC	kW	3.0	6.0	9.0	3.0	6.0	10	24	
at 565 VDC	kW	-	-	-	5.0	10	16.5	40	
at 680 VDC	kW	-	-	-	6.0	12	20	48	
Fan noise emission at 1m, min/max	dB(A)	< 50 / 60						< 50 / 76	
Thermal dissipation, disabled	W	12	12	12	12	12	12	15	
Thermal dissipation at rated current	W	50	80	140	65	105	210	395	
Motor inductance									
minimum at 120 VAC	mH	1.2	0.6	0.3	-	-	-	-	
minimum at 240 VAC	mH	2.4	1.2	0.6	3.1	1.5	1.1	0.5	
minimum at 400 VAC	mH	-	-	-	5.1	2.6	1.8	0.85	
minimum at 480 VAC	mH	-	-	-	6.1	3.1	2.1	1.0	
maximum	mH	240	120	60	610	310	180	80	
Regeneration Braking		(→ # 40)							
Brake output									
Voltage (±10%)	VDC	24							
Voltage power saving	VDC	12 to 24							
Output under current fault	mA	100 (required for fault detection)							
Output over current fault	A	2.25 (required for fault detection)							
Output current, maximum	A	2.1							

## 6.5.2 Dual axis variants (D: I1=I2)

### 6.5.2.1 Mains supply data, 1 phase AC, type AKD2G-Sxx- (D)

Input data	Units	6V03D	6V06D
Operational supply voltage (line to line)	VAC	12 to 265	
Rated supply voltage	VAC	100 to 240	
Rated supply input frequency ( $\pm 5\%$ )	Hz	50 to 60	
Permitted switch on/off frequency	1/h	30	
Rated input VA at 240 V	kVA	1.7	3.1
Rated input current	A	7.2	13
Max. inrush current	A	10	
Rated DC bus link voltage	VDC	140 to 340	

### 6.5.2.2 Mains supply data, 3 phase AC, type AKD2G-Sxx- (D)

Input data	Units	6V03D	6V06D	7V03D	7V06D
Operational supply voltage (line to line)	VAC	12 to 265		24 to 525	
Rated supply voltage	VAC	100 to 240		200 to 480	
Rated supply input frequency ( $\pm 5\%$ )	Hz	50 to 60			
Permitted switch on/off frequency	1/h	30			
Rated input VA at 240 V (* at 480 V)	kVA	2.2	4.0	4.4*	7.2*
Rated input current	A	5.3	9.7	5.3	8.7
Max. inrush current (at 240 V/480 V, 20°C)	A	10			
Rated DC bus link voltage	VDC	140 to 340		280 to 680	

### 6.5.2.3 Mains supply data, DC, type AKD2G-Sxx- (D)

Input data	Units	6V03D	6V06D	7V03D	7V06D
Operational supply voltage (DC+ to DC-)	VDC	17 to 370		34 to 740	
Rated supply voltage	VDC	140 to 340		280 to 680	
Permitted switch on/off frequency	1/h	30			
Rated input power at 340 V (* at 680 V)	kW	1.25	2.5	2.5*	5*
Rated input current	A	4	8	4	8
Max. inrush current through AC input	A	10			
Rated DC bus link voltage	VDC	140 to 340		200 to 680	

### 6.5.2.4 Output data, type AKD2G-Sxx- (D)

Drive current and power output values are listed for Axis1/Axis2.

Parameter	Units	6V03D	6V06D	7V03D	7V06D
Continuous output current ( ± 3%)	Arms	3/3	6/6	3/3	6/6
Peak output current (for 5s, ±3%)	Arms	9/9	18/18	9/9	18/18
<b>Continuous motor shaft output power at rated input current</b>					
at 1 x 120 VAC	kW	0.22/0.22	0.44/0.44	-	-
at 1 x 240 VAC	kW	0.44/0.44	0.875/0.875	0.44/0.44	0.875/0.875
at 3 x 120 VAC	kW	0.31/0.31	0.625/0.625	-	-
at 3 x 240 VAC	kW	0.625/0.625	1.25/1.25	0.625/0.625	1.25/1.25
at 3 x 400 VAC	kW	-	-	1.05/1.05	2.1/2.1
at 3 x 480 VAC	kW	-	-	1.25/1.25	2.5/2.5
at 170 VDC	kW	0.31/0.31	0.625/0.625	-	-
at 340 VDC	kW	0.625/0.625	1.25/1.25	0.625/0.625	1.25/1.25
at 565 VDC	kW	-	-	1.05/1.05	2.1/2.1
at 680 VDC	kW	-	-	1.25/1.25	2.5/2.5
<b>Peak output power (for 1 s)</b>					
at 1 x 120 VAC	kW	1.1/1.1	2.1/2.1	-	-
at 1 x 240 VAC	kW	2.1/2.1	4.2/4.2	-	-
at 3 x 120 VAC	kW	1.5/1.5	3.0/3.0	-	-
at 3 x 240 VAC	kW	3.0/3.0	6.0/6.0	3.0/3.0	6.0/6.0
at 3 x 400 VAC	kW	-	-	5.0/5.0	10/10
at 3 x 480 VAC	kW	-	-	6.0/6.0	12/12
at 170 VDC	kW	1.5/1.5	3.0/3.0	-	-
at 340 VDC	kW	3.0/3.0	6.0/6.0	3.0/3.0	6.0/6.0
at 565 VDC	kW	-	-	5.0/5.0	10/10
at 680 VDC	kW	-	-	6.0/6.0	12/12
Fan noise emission at 1m, min/max	dB(A)	< 50 / 60			
Thermal dissipation, disabled	W	15	15	15	15
Thermal dissipation at rated current	W	90	150	120	210
<b>Motor inductance</b>					
minimum at 120 VAC	mH	1.2/1.2	0.6/0.6	-	-
minimum at 240 VAC	mH	2.4/2.4	1.2/1.2	3.1/3.1	1.9/1.9
minimum at 400 VAC	mH	-	-	5.1/5.1	3.2/3.2
minimum at 480 VAC	mH	-	-	6.1/6.1	3.8/3.8
maximum	mH	240/240	120/120	610/610	380/380
<b>Regeneration Braking</b>		(→ # 40)			
<b>Brake output</b>					
Voltage (±10%)	VDC	24			
Voltage power saving	VDC	12 to 24			
Output under current fault	mA	100 (required for fault detection)			
Output over current fault	A	2.25 (required for fault detection)			
Output current, maximum	A	2.1 per brake			

### 6.5.3 Steady State Control Current per Brake Option

Auxiliary 24 VDC ( $\pm 10\%$ , check voltage drop) Supply Voltage (PELV)	Units	Current
Base current for all AKD2G Sxx-xV 3-12 A drives with NO brake	A	< 1
Base current for an AKD2G Sxx-7V24S drive with NO brake	A	< 1.5
Additional current load per brake (maximum 2 brakes)*	A	< 1.8

\* To calculate current for a drive plus a brake, add base drive current plus the current value for each brake.

**For example:**

1. AKD2G-Sxx-6V06D with two brakes: Net 24 V current  $< 1 + 2 \cdot (1.8) = 4.6$  A
2. AKD2G-Sxx-7V24S with one brake: Net 24 V current  $< 1.5 + 1.8 = 3.3$  A

## 6.6 Electrical Motor Braking

### 6.6.1 Drive dynamic braking

Drive Dynamic braking is a method to slow down a servo system by dissipating the mechanical energy driven by the motor back EMF.

**NOTE**

Drive dynamic braking is not functional safe.

The AKD2G has a built in advanced drive dynamic braking mode which operates fully in hardware. When activated, the drive powers the motor terminals with voltages to maximize the stopping force per amount of motor current. This advanced method forces all of the dynamic braking current to be stopping current and insures the fastest stopping per ampere of motor terminal current.

- When current is not being limited, the mechanical energy is being dissipated in the motor winding resistance.
- When current is being limited, energy is returned to the drive bus capacitors.
- The drive also limits the maximum dynamic braking motor terminal current by using the *AXIS#.DBLIMIT* parameter to insure that the drive, motor, and customer load do not see excessive currents/forces.

Whether and how the AKD2G uses dynamic drive braking depends on (*AXIS#.DISMODE*).

### 6.6.2 Regeneration braking

When the amount of returned energy from the motor builds the bus capacitor voltage up enough the drive activates the regenerative braking circuit to start dumping the returned energy in the regen resistor (also called regenerative resistor or brake resistor). All AKD2G offer internal resistor plus the ability to connect an external resistor depending on the application requirements.

**NOTE**

External regen resistors are described in the regional *Accessories Manual*.

#### 6.6.2.1 Functional description

##### 1. Individual drives, not coupled through the DC bus link circuit (+DC, -DC)

When the energy fed back from the motor has an average or peak power that exceeds the preset level for the brake power rating, the drive generates the warning "W2010 Regen Energy Critical". If the power exceeds the set fault level, the regenerative circuit will switch off and the drive will disable.

##### 2. Several drives coupled through the DC bus link (+DC, -DC)

Using the built-in regenerative circuit, several drives of the same series can be operated from a common DC-bus link (→ # 92), without any additional measures. 90% of the combined power of all the coupled drives is always available for peak and continuous power. If the power of the drive with the lowest switch-off threshold (resulting from tolerances) exceeds the set fault level, the regenerative circuit will switch off on that drive.

**Switch-off on over voltage:** With the regenerative circuit switched off, the returned energy is not dissipated and therefore the DC-bus link level increases. The drive reports an over-voltage fault if the DC-bus voltage threshold is exceeded. When this happens, the drive power stage is immediately disabled and the load coasts to a stop with the fault message "F2006 Bus Over voltage".

The ready to operate contact (terminals X21/B5-B6) is opened (→ # 161).

**NOTE**

Observe the regeneration time (some minutes) after full load with peak brake power.

### 6.6.2.2 Technical data for AKD2G-Sxx-6V

Technical data for the regenerative circuit depends on the drive type and the mains voltage. Supply voltages, capacitance, and switch-on voltages are all nominal values.

Brake circuit		AC Supply	
AKD2G-Sxx-	Rated data	Units	120V / 240V
6Vxxy all types	Regen start voltage at rated supply voltage	V	380
	Overvoltage limit	V	420
	Maximum regenerative duty cycle	%	35*
	Internal regen resistor	Ω	15
	Continuous power, internal resistor	W	100
	Peak brake power, internal resistor (0.5s)	kW	3 / 9
	External regen resistor (recommended 15 Ω)	Ω	≥10
	Continuous brake power, external resistor	kW	3
	Peak brake power, external (1s)	kW	5 / 14
6V03S, 6V06S	Absorption energy in capacitors (±20%)	Ws	6 / 23
	DC Bus Capacitance	μF	1640
6V12S, 6V03D, 6V06D	Absorption energy in capacitors (± 20%)	Ws	9 / 35
	DC Bus Capacitance	μF	2460

\* depends on connected regen resistor power.

### 6.6.2.3 Technical data for AKD2G-Sxx-7V

Technical data for the regenerative circuit depends on the drive type and the mains voltage. Supply voltages, capacitance, and switch-on voltages are all nominal values.

#### AKD2G-Sxx-7V03 to AKD2G-Sxx-7V12

Brake circuit		AC Supply		
AKD2G-Sxx-	Rated data	Units	240V	400V/480V
7V03S ,7V06S, 7V12S, 7V03D, 7V06D	Regen start voltage at rated supply voltage	V	380	633 / 760
	Overvoltage limit	V	420	840
	Maximum regenerative duty cycle	%	35*	
	Internal regen resistor	Ω	33	
	Continuous power, internal resistor	W	100	
	Peak brake power, internal resistor (0.5s)	kW	4	17
	External regen resistor (recommended 33 Ω)	Ω	≥25	
	Continuous brake power, external resistor	kW	2	6
7V03S, 7V06S	Absorption energy in capacitors (±20%)	Ws	3	30 / 18
	DC Bus Capacitance	μF	235	
7V12S, 7V03D, 7V06D	Absorption energy in capacitors (±20%)	Ws	6	50 / 35
	DC Bus Capacitance	μF	470	

#### AKD2G-Sxx-7V24

Brake circuit		AC Supply		
AKD2G-Sxx-	Rated data	Units	240V	400V/480V
7V24S	Regen start voltage at rated supply voltage	V	380	633 / 760
	Overvoltage limit	V	420	840
	Maximum regenerative duty cycle	%	35*	
	Internal regen resistor	Ω	15	
	Continuous power, internal resistor	W	140	
	Peak brake power, internal resistor (0.5s)	kW	9	38
	External regen resistor (recommended 10 Ω)	Ω	≥15	
	Continuous brake power, external resistor	kW	3	10
	Peak brake power, external (1s)	kW	14	55
	Absorption energy in capacitors (±20%)	Ws	15	125 / 80
	DC Bus Capacitance	μF	1200	

\* depends on connected regen resistor power.



## 6.7 LCD Display and Push-buttons (B1, B2)

The drive offers an LCD display and two push-buttons B1 / B2 for navigation.

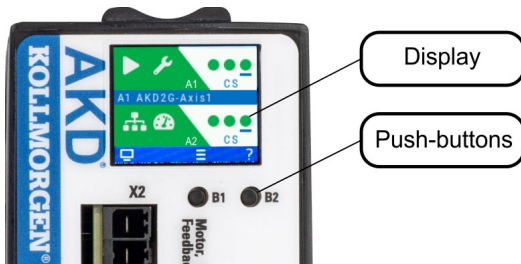

### Push-button actions

A short button press invokes the action corresponding to the symbol directly above the button. On the dashboard for example,

- a short press on B1 causes the menu system to appear, and
- a short press on B2 causes a help screen to appear.
- A long press (greater than 2 seconds) on B2 returns the display to the previous screen.

B1 / B2 Functions	Description
Boot from SD card	Push both buttons during power up to boot with data from SD card. Press the buttons first, then hold it down while turning on the 24 V power supply.
Boot from flash fallback image	Remove the SD card, then press both buttons and hold them down while turning on the 24 V power supply to boot from an on-board recovery image. The fallback image includes a set of bootloader, operational, and control FPGA that implements sufficient programming support to update missing or corrupt files.

### LCD display

- Left Colored section
  - Color: axis status (enabled, disabled, or faulted).
  - First icon: axis command source (analog, service, electronic gearing, or fieldbus).
  - Second icon: axis operation mode (torque, velocity, or position).
  - Axis ID: A1 or A2.
- Right Non-colored section:
  - No Fault/Warning: three virtual LEDs corresponding to axis disable sources (Safe Torque Off, Hardware Enable, and Controlled Stop).
  - Faults or warnings: fault or warning code.
- Center blue bar:
  - Drive and axis names
  - IP address
  - Drive model number
  - Firmware version
- Bottom blue bar:
  - indicates whether the service port is connected to WorkBench, and
  - shows the actions that will be invoked by pushing the B1 / B2 buttons.

### Dual axis LCD display

For dual-axis drives, the top section shows axis 1 information, the bottom section those for axis 2.

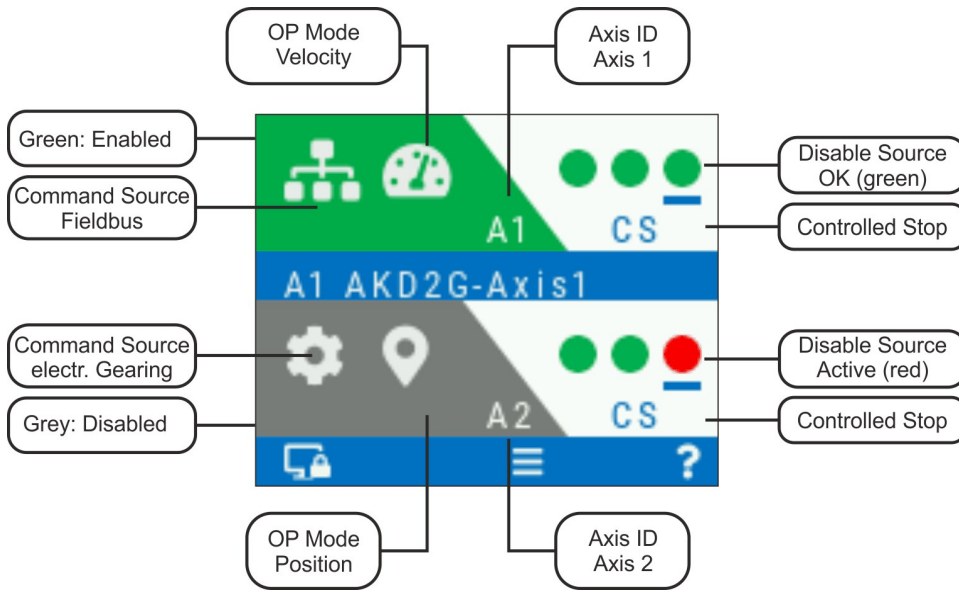

### Single axis LCD display

For single axis drives, the top section shows axis 1 information while the section between the center and bottom bars is a data area where some important actual values of the axis are visible: position, velocity, current.

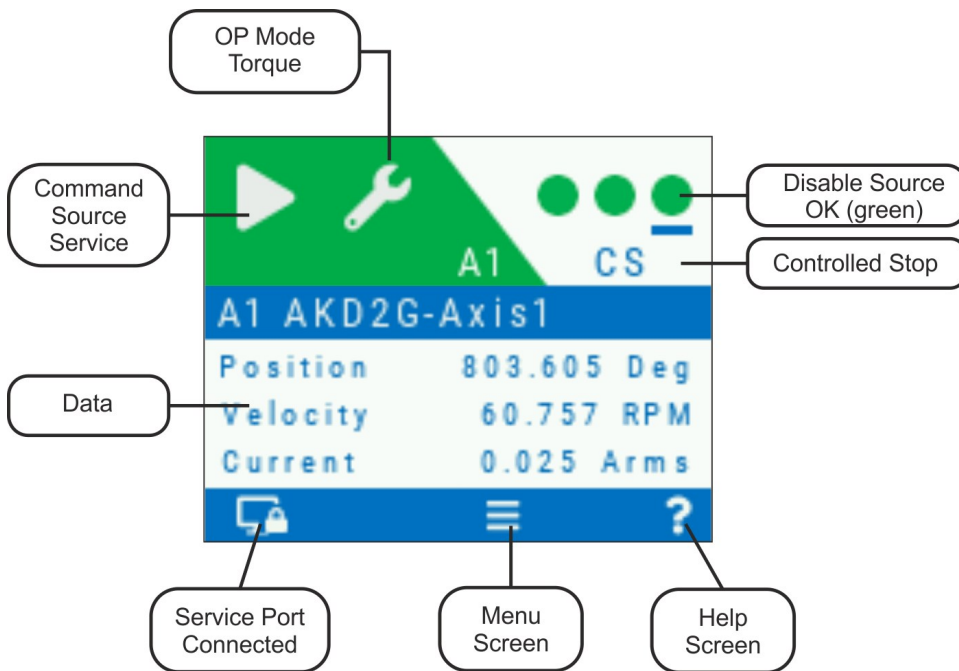

### Faults and Warnings

The display shows the code of the fault or warning that occurred. If a fault occurs, the color of the left section switches to red. Navigate with B1 / B2 to the Fault screen to see a short description of the fault or warning.

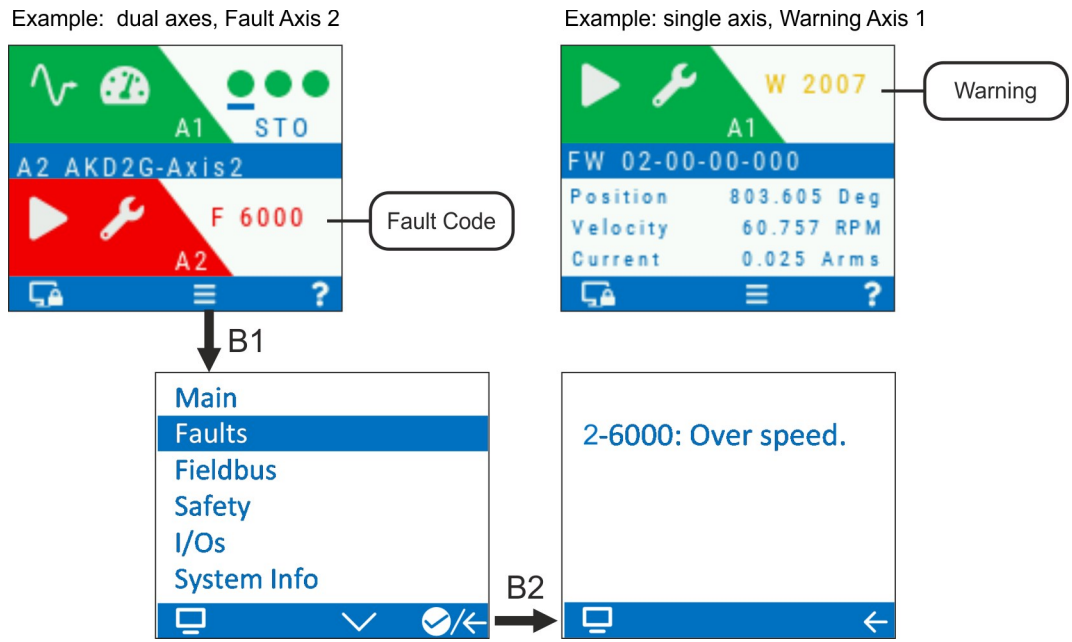

See WorkBench Onlinehelp for more details.

## 6.8 SD Card Slot



AKD2G contains an SD card slot

- to recover the drive from failure and
- to backup and restore firmware and parameters and
- to store AKD2G logs.

These features can be accessed from the drive display using push-buttons B1/B2.

### Supported SD card types

SD cards are formatted by the manufacturer. The following table outlines the SD card types and AKD2G support.

SD Type	File System	Capacity	Supported
SD (SDSC)	FAT16	1MB to 2GB	<b>YES</b>
SDHC	FAT32	4GB to 32GB	<b>YES</b>
SDXC	exFAT (Microsoft)	>32GB to 2TB	<b>NO</b>

### Features

Refer to the WorkBench online help for complete information.

- **To recover AKD2G from an SD card:**  
Remove 24V. Press the buttons B1 and B2 to apply 24V. Release buttons after the display is updated.
- **Backup/Restore operations:**  
Only possible when no program is running and the drive is disabled.  
Note that if a fault occurs during Backup/Restore operations, the fault number shows up in the display, error codes (→ # 177).
  - Drive Firmware Backup/Restore
  - Drive Parameters Save/Restore
  - Storing drive logs
  - Storing drive troubleshooting information in case of failure.
  - Drive recovery in case of failure.

## 7 Mechanical Installation

---

<b>7.1 Important Notes</b> .....	<b>48</b>
<b>7.2 Guide to Mechanical Installation</b> .....	<b>48</b>
<b>7.3 Dimensions</b> .....	<b>49</b>

## 7.1 Important Notes



### **CAUTION** High EMC Voltage Level!

Risk of electrical shock, if the servo amplifier (or the motor) is not properly EMC-grounded.

- Use electrically conductive mounting plates, e. g. made of aluminum or galvanized steel.
- In unfavourable circumstances, use copper mesh tape between the earthing bolts and earth potential to deflect currents.

### **NOTICE**

Protect the drive from impermissible stresses. In particular, do not let any components become bent or any insulation distances altered during transport and handling. Avoid contact with electronic components and contacts.

## 7.2 Guide to Mechanical Installation

You need at least the following tools to install the AKD2G:

- M5 hexagon socket-cap screws (ISO 4762)
- 4 mm hexagon ball head screwdriver
- No. 2 Phillips head screwdriver
- Small slotted screwdriver

Your specific installation may require additional tools.

### **NOTICE**

Do not mount the drive right next to devices that produce magnetic fields. Strong magnetic fields can directly affect internal components. Install the drive with distance to such devices and/or shield the magnetic fields.

Install the drive unit as follows:

1. Mount the drive in a closed control cabinet (ambient conditions (→ # 33). The site must be free from conductive or corrosive materials. For the mounting position in the cabinet see (→ # 49).
2. Check that the ventilation of the drive is unimpeded and keep within the permitted ambient temperature (→ # 33). Keep the required space clearance above and below the drive (→ # 49).
3. Ensure that there is an adequate flow of cool, filtered air into the bottom of the control cabinet, or use a heat exchanger (→ # 33).  
**Notice: The drive will switch itself off in case of overheating.**
4. If you are using a cooling system for the control cabinet, position the cooling system in a way that condensation water cannot drip onto the drive or peripheral devices.
5. Assemble the drive and power supply next to each other on the conductive, grounded mounting plate in the cabinet.
6. Ground the mounting plate, motor housing and CNC-GND of the control system. For EMC-compliant shielding and grounding see (→ # 58).

### 7.3 Dimensions

**NOTE** Mounting: 3 x M5 hexagon socket screws to ISO 4762, 4 mm hexagon ball head screwdriver

AKD2G-Sxx-						
Parameter	Unit	6V03S, 6V06S, 6V12S	6V03D, 6V06D	7V03S, 7V06S	7V03D, 7V06D, 7V12S	7V24S
Weight (without mating connectors)	kg	2.4	2.5	2.5	2.7	6.4

General 6V and 7V models with X3 connector

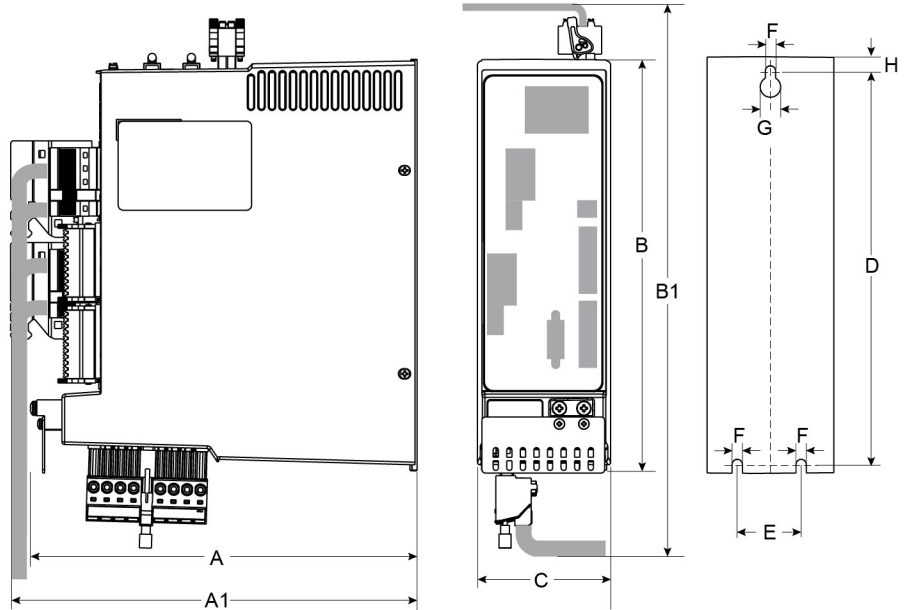

7V24S model with X3A and X3B connectors

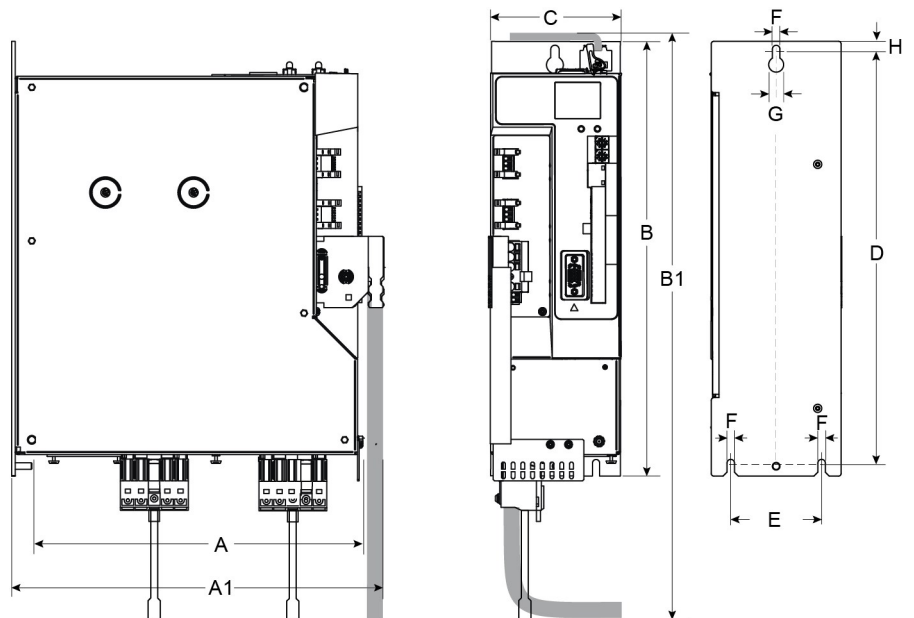

**NOTE** Outline width and height dimensions are measured on footprint level (mounting plate). Dimensions on the front plate are slightly smaller.

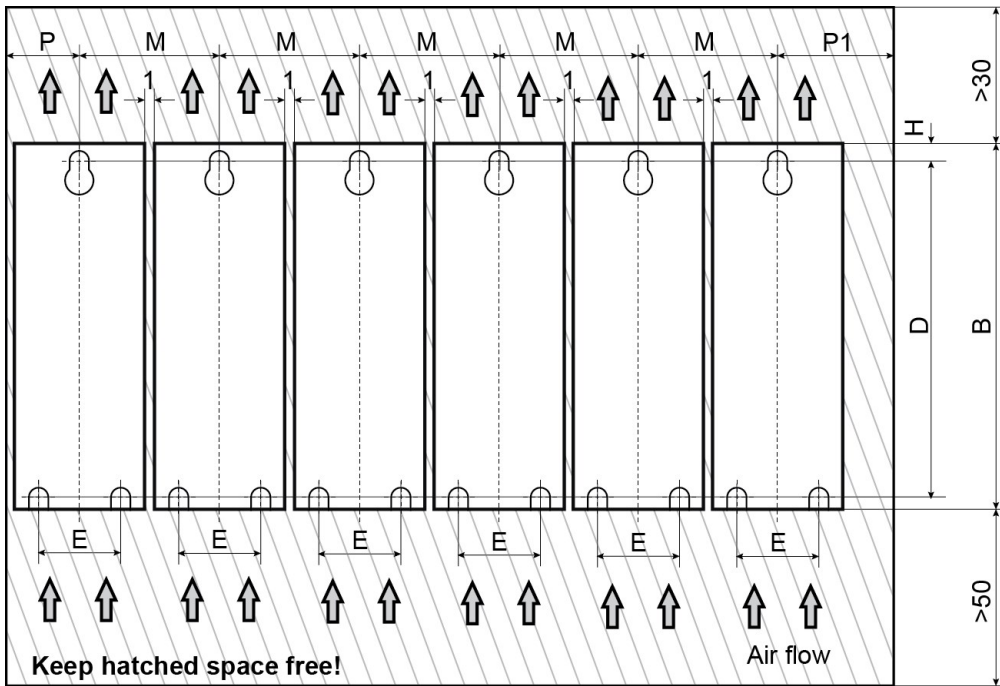

Model	Unit	A	A1	B	B1	C	D	E	F	G	H	M	P	P1
AKD2G-Sxx-6V (3 to 12 A)	mm	221	232	235	303	76	221.5	36	5.8	11.5	7	77	40	40
AKD2G-Sxx-7V (3 to 12 A)	mm	221	232	272	340	75	259	36	5.8	11.5	6	76	40	40
AKD2G-Sxx-7V (24 A)	mm	274	291	335	450*	100	319	70	5.8	11.5	6	105	55*	55

\*X3A and X3B with bracket option: P ≥ 125 mm, B1 ≥ 520 mm.



## 8 Electrical Installation

---

8.1 Important Notes .....	52
8.2 Guide to electrical installation .....	53
8.3 Wiring .....	54
8.4 EMI Noise Reduction .....	58
8.5 Connection Overview .....	63
8.6 Power and Logic Voltage Supply (X3/X10) .....	78
8.7 DC Bus link connector X3/X3B .....	92
8.8 Regen resistor connector X3/X3B .....	95
8.9 Motor Power, Brake and Feedback connection .....	96
8.10 Feedback Connection .....	104
8.11 Gearing .....	139
8.12 Ethernet Fieldbus Interface Connector X11/X12 .....	142
8.13 CAN-Bus Interface connector X13/X14 .....	145
8.14 Service Interface connector X20 .....	148
8.15 Modbus TCP connector X20 .....	149
8.16 I/O Connectors X21/X22/X23 .....	150

## 8.1 Important Notes

### NOTICE

Only professional staff who are qualified in electrical engineering are allowed to install the drive. Wires with color green with one or more yellow stripes must not be used other than for protective earth (PE) wiring.



### **DANGER** High Voltage up to 900 V!

There is a danger of serious personal injury or death by electrical shock or electrical arcing. Capacitors can still have dangerous voltages present up to 5 minutes after switching off the supply power. Control and power connections can still be live, even if the motor is not rotating.

- Only install and wire the equipment when it is not live.
- Make sure that the cabinet is safely disconnected (for instance, with a lock-out and warning signs).
- Never remove electrical connections to the drive while it is live.
- Wait at least 5 minutes after disconnecting the drive from the main supply power before touching potentially live sections of the equipment (e.g. contacts) or undoing any connections.
- To be sure, measure the voltage in the DC bus link and wait until it has fallen below 50 V.

### NOTICE

Wrong mains voltage, unsuitable motor or wrong wiring will damage the drive. Check the combination of drive and motor. Compare the rated voltage and current of the units. Implement the wiring according to the matching connection diagram, see (→ # 66) and following.

Make sure that the maximum permissible rated voltage at the terminals L1, L2, L3 or +DC, –DC is not exceeded by more than 10% even in the most unfavorable circumstances (see IEC 60204-1).

### NOTICE

Excessively high external fusing will endanger cables and devices. The fusing of the mains power and logic power must be installed by the user. Hints for use of Residual-current circuit breakers (RCD) (→ # 19).

### NOTICE

Since the leakage current to PE is more than 3.5 mA, in compliance with IEC61800-5-1 the PE connection must either be doubled or a connecting cable with a cross-section >10 mm<sup>2</sup> must be used. Deviating measures according to regional standards might be possible.

### NOTICE

The drive status shall be monitored by the PLC to acknowledge critical situations. We recommend wiring the ready to operate relay contact in series into the emergency off circuit of the installation. The emergency off circuit must operate the supply contactor.

### NOTE

It is permissible to use WorkBench to change the settings of the drive. Any other alteration will invalidate the warranty.

## 8.2 Guide to electrical installation

Kollmorgen recommends to install the drive electrical system as follows:

1. Select cables in accordance with IEC 60204 (→ # 55).
2. Install shielding and ground the drive.  
For EMC-compliant shielding and grounding, see (→ # 58).  
Ground the mounting plate, motor housing and CNC-GND of the control system.
3. For functional safety information, see (→ # 179).
4. Wire the drive and connectors.  
Observe the "Recommendations for EMI noise reduction": (→ # 58).
  - Wire the "Ready to Operate" contact into the emergency off circuit of the system.
  - Connect the digital control inputs and outputs.
  - Connect up analog ground (also if a fieldbus is used).
  - Connect the analog input source, if required.
  - Connect the motor (hybrid cable or power, brake and feedback cables).
  - Connect shielding at both ends.
  - If required, connect the external regen resistor (with fusing).
  - Connect the mains filter FN2090/FN3288 with AKD2G-Sxx-6V (with shielded lines between filter and drive) for second environment requirements to product category C2.
  - Connect the auxiliary voltage supply
  - Connect the main electrical supply.  
Check maximum permitted voltage value (→ # 35).
  - Check proper use of residual-current circuit breakers (RCD): (→ # 19).
  - Connect the PC (→ # 148) for setting up the drive.
5. Check the wiring against the wiring diagrams:
 

Overview AKD2G single axis	(→ # 66)
Overview AKD2G dual-axis	(→ # 68)
Connector pinout	(→ # 69)
Mains power supply:	(→ # 81)
Logic power supply:	(→ # 91)
DC Bus Link:	(→ # 92)
External Regen Resistor:	(→ # 95)
Motor single cable connection:	(→ # 97)
Motor dual cable connection:	(→ # 99)
Motor Holding Brake:	(→ # 101)
Feedback Connection	(→ # 104)
Encoder emulation:	(→ # 139)
Electronic gearing:	(→ # 139)
Master Slave:	(→ # 141)
EtherNet Fieldbus interface:	(→ # 142)
CAN-Bus interface:	(→ # 145)
Service interface:	(→ # 148)
Modbus interface:	(→ # 149)
Digital and analog I/O:	(→ # 150)
Functional Safety option 1:	(→ # 183)

### 8.3 Wiring

**NOTICE**

Only professional staff who are qualified in electrical engineering are allowed to install the drive. Wires with color green with one or more yellow stripes must not be used other than for protective earth (PE) wiring. When installing or replacing cables, use only standardized components, which comply to the cable and wire requirements (→ # 55).

#### 8.3.1 General



**DANGER High Voltage up to 900 V!**

There is a danger of serious personal injury or death by electrical shock or electrical arcing.

- Only install and wire the equipment when it is not live, that is, when neither the electrical supply nor the 24 V auxiliary voltage nor the supply voltages of any other connected equipment is switched on.
- Make sure that the cabinet is safely disconnected (for instance, with a lock-out and warning signs). The individual voltages are switched on for the first time during setup.

**NOTE**

The chassis ground symbol, which is used in all the wiring diagrams, indicates that you must take care to provide an electrically conductive connection with the largest feasible surface area between the unit indicated and the mounting plate in the control cabinet. This connection is for the effective grounding of HF interference, and must not be confused with the PE-symbol (PE = protective earth, safety measure as per IEC 60204).

#### 8.3.2 Mating connectors

**NOTE**

- Connectors X1, X2, X4, X5, X10T, X21, X22 are spring clamp connectors.
- X3/X3T connector with screw terminals, tightening torque 0.5...0.6 Nm (4.4...5.3 in-lbs).
- X3A/X3B connector with screw terminals, tightening torque 2 Nm (18 in-lbs).
- Connectors X4, X5, X22 and X23 are optional.

#	Description	Type	Max. Cross Section
X1/2	Motor, two wire feedback, holding brake	Connector, 4 pol. power	10 mm <sup>2</sup> , 8 awg
		Connector, 4 pol. signal	0.5 mm <sup>2</sup> , 21 awg
X3/X3T	Mains power, regen resistor, DC-Bus	Connector or T-type, 8 pol.	6 mm <sup>2</sup> , 10 awg
X3A/X3B	Mains power, regen resistor, DC-Bus	Connector, 4 pol. power	6 mm <sup>2</sup> , 10 awg
X4	Second brake	Connector, 3 pol.	1.5 mm <sup>2</sup> , 16 awg
X5	Second feedback, two wire	Connector, 3 pol.	1.5 mm <sup>2</sup> , 16 awg
X10T	24V power supply	T-type connector , 2 pol.	2.5 mm <sup>2</sup> , 14 awg
X11/12	EtherNet Fieldbus	RJ45	0,5 mm <sup>2</sup> , 21 awg
X13/14	CAN In/Out	RJ25	0,5 mm <sup>2</sup> , 21 awg
X20	Service Port	RJ45	0,5 mm <sup>2</sup> , 21 awg
X21	I/O control signals	Connector, 2x11 pol.	1.5 mm <sup>2</sup> , 16 awg
X22	I/O control signals	Connector, 2x10 pol.	1.5 mm <sup>2</sup> , 16 awg
X23	Conventional feedback models	SubD 15pol. HD (female)	0,5 mm <sup>2</sup> , 21 awg

### 8.3.3 Cable and Wire Requirements

#### 8.3.3.1 Cable material

For information on the chemical, mechanical, and electrical characteristics of the cables please refer to the *Kollmorgen 2G Cable Guide* or contact customer support.

#### NOTE

To reach the maximum permitted cable length, you must use cable material with the following capacitance requirements:

- Motor power cable: less than 150 pF/m (phase core to shield capacitance)
- Motor Feedback cable: less than 120 pF/m (signal core to shield capacitance)
- Hybrid motor cable:
  - less than 120 pF/m (phase core/core capacitance)
  - less than 210 pF/m (phase core/shield capacitance)
  - less than 120 pF/m (signal core/core capacitance)
  - less than 210 pF/m (signal core/shield capacitance)
  - BUS Element: 45 pF/m @ 800kHz & charact. wave resistance  $110 \pm 10 \Omega$  @ 10MHz

#### 8.3.3.2 Cable length

#### NOTICE

Cables should not exceed the maximum lengths stated below. The recommended maximum cable length of motor cables depends on the used cable material and the feedback type. Cable functionality is only guaranteed up to the maximum length when using unmodified Kollmorgen engineered cables.

#### Motor cables (X1, X2, X4, X5, X23, X41)

Length of motor power cables, feedback cables and motor brake cables is equal.

AKM2G		AKM			
Performance Line Cables		Performance Line Cables		Value Line Cables	
Feedback	Max. Length [m]	Feedback	Max. Length [m]	Feedback	Max. Length [m]
SFD3	50	All	25	All	12
DSL	25				
Endat 2.2	25				
Resolver	50				

#### I/O cables (X21, X22)

#### NOTICE

Maximum distance for unshielded I/O lines is 3 m inside the cabinet. If the I/O cable leaves the cabinet, it must be EMC shielded.

#### 8.3.3.3 T-Connector wiring

If you use mating T-connectors for 24 VDC supply, mains voltage supply and DC-Bus link, you must prepare the connecting cables with wire end ferrules.

You can prepare cables with cross-section 2.5 mm<sup>2</sup> (up to to 6 mm<sup>2</sup>) with a uniform length of 170 mm, if the modules are lined up close together.

Use wire end ferrules with plastic collars, for example 2.5 mm<sup>2</sup> x 17 mm.

### 8.3.3.4 Cable cross sections and requirements

The tables below describe the recommended interface cross sections and cable requirements related to AKD2G in accordance with IEC 60204. For multi-axes systems, observe the specific operating conditions for your system.

Power Cables		Cross Section		Remarks
		EU	US	
Mains supply	1x3 A:	1.5 mm <sup>2</sup>	14 awg	600 V rated ,minimum 75°C
	2x3 A:	1.5 mm <sup>2</sup>	14 awg	
	1x6 A:	1.5 mm <sup>2</sup>	14 awg	
	2x6 A:	2.5 mm <sup>2</sup>	14 awg	
	1x12 A:	2.5 mm <sup>2</sup>	14 awg	
	1x24 A:	6 mm <sup>2</sup>	10 awg	
24 V supply	max.	2.5 mm <sup>2</sup>	14 awg	Single core Flexible Class 5
DC bus link, Regen resistor	3/6 A:	1.5 mm <sup>2</sup>	14 awg	1000 V rated, min. 75°C, shielded for lengths >0.20 m
	12 A:	2.5 mm <sup>2</sup>	14 awg	
	24 A:	6 mm <sup>2</sup>	10 awg	
Analog I/Os	min.	0.25 mm <sup>2</sup>	24 awg	shielded twisted pairs
Digital I/Os		0.5 mm <sup>2</sup>	20 awg	single core

### Motor power cable (power) & motor combination cable (power & brake)

Cross Section [mm]		Current Carrying Capacity	Remarks
Cable	Combi Cable		
(4x1)	(4x1.0+(2x0.75))	0A < I <sub>rms</sub> ≤ 10.1A	1000 V Rated, 80°C
(4x1.5)	(4x1.5+(2x0.75))	10.1A < I <sub>rms</sub> ≤ 13.1A	Current carrying capacity acc. to IEC 60204-1:2006 Table 6, Column B2
(4x2.5)	(4x2.5+(2x1.0))	13.1A < I <sub>rms</sub> ≤ 17.4A	
(4x4)	(4x4.0+(2x1.0))	17.4A < I <sub>rms</sub> ≤ 23A	The brackets (...) show the shielding.
(4x6)	(4x6.0+(2x1.0))	23A < I <sub>rms</sub> ≤ 30A	

### Motor feedback cable

Type	Cross Section [mm]	Remarks
Resolver	(4x2x0.25)	300 V rated, 80°C
EnDat 2.1, BiSS B	(6x2x0.25)	
HIPERFACE	(5x2x0.25)	Shielded twisted pairs
EnDat 2.2, BiSS C	(5x2x0.25)	The brackets (...) show the shielding.
SFD	(3x2x0.25)	
Comcoder	(8x2x0.25)	

### Motor hybrid cable

Type	Cross Section [mm]	Current Carrying Capacity	Remarks
SFD3/DSL	(4x1.0+(2x0.34)+(2x0.75))	0A < I <sub>rms</sub> ≤ 10.1A	1000 V rated, 80°C
SFD3/DSL	(4x1.5+(2x0.34)+(2x0.75))	10.1A < I <sub>rms</sub> ≤ 13.1A	Current carrying capacity acc. to IEC 60204-1:2006 Table 6, Column B2
SFD3/DSL	(4x2.5+(2x0.34)+(2x1.0))	13.1A < I <sub>rms</sub> ≤ 17.4A	
SFD3/DSL	(4x4.0+(2x0.34)+(2x1.0))	17.4A < I <sub>rms</sub> ≤ 23A	4 power lines & 2 brake lines & 2 SFD3/DSL signal lines
SFD3/DSL	(4x6.0+(2x0.34)+(2x1.0))	23A < I <sub>rms</sub> ≤ 30A	
Endat 2.2	(4x1.5+(2x0.75)+(2x2x0.14+2x0.25))	10.1A < I <sub>rms</sub> ≤ 13.1A	or 6 EnDat 2.2 signal lines
Endat 2.2	(4x4.0+(2x1.0)+(2x2x0.14+2x0.25))	17.4A < I <sub>rms</sub> ≤ 23A	

### 8.3.4 Protective Earth Connection

Protective Earth connection of the system components is a safety measure per IEC 60204. Ensure the proper grounding of all components with the PE rail in the control cabinet as reference potential. Connect each ground individually with the intended grounding cable (neutral point connection).

The leakage current from AKD2G against PE is more than 3.5 mA. In accordance with EN 61800-5-1, the PE connection must therefore either be double implemented or a connection cable with >10 mm<sup>2</sup> cross-section used.

In order to keep the impedance as low as possible, we recommend a copper earthing strap for the PE connection on the PE block.

#### NOTE

Wire the PE connections immediately after installing the devices as the first electrical connection. Now you insert all the other lines and connectors. For disassembly, release the PE connections as the last connection.

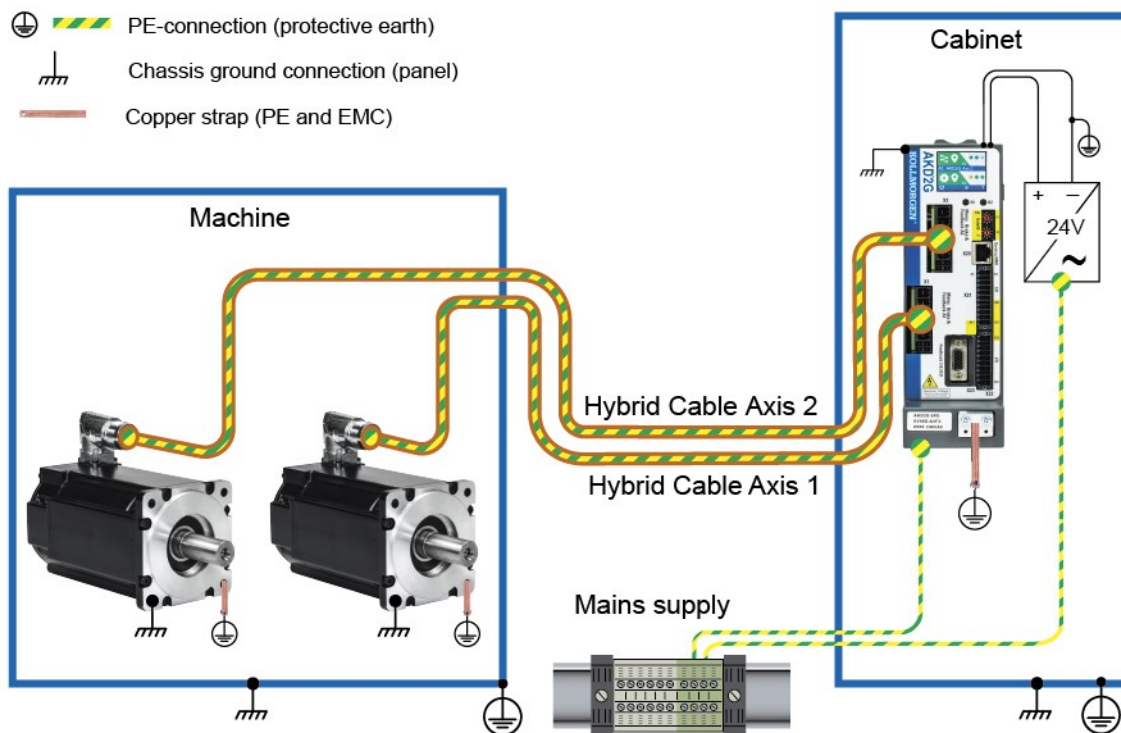

#### NOTE

For the use of residual current protective devices (RCD), refer to (→ # 19).

## 8.4 EMI Noise Reduction



### **CAUTION** Electromagnetic Fields!

Electromagnetic radiation may lead to potential hazardous danger (warming, failure of implants), when acting on electrically conductive materials.

- Work on the electrical installation may only be performed by trained and qualified personnel, in compliance with the regulations for safety at work, and only with switched off mains supply and secured against restart.
- Do not remove grounding, equipotential bonding and radiation-reducing shields.

### 8.4.1 Reducing EMI noise

With the help of the following instructions, you can reduce electrical interference in the application:

- **Ensure good connections between the cabinet components.** Connect the back panel and cabinet door to the cabinet body using several conductive braids. Never rely on hinges or mounting bolts for ground connections.
- **Ensure good ground connection.** Connect from cabinet to proper earth ground. Ground leads should be the same gauge as the leads to main power, but must cover the regional legal requirements, example (→ # 57).
- **Use Kollmorgen cables.** Route power and control cables separately, Kollmorgen recommends a distance of at least 200 mm to improve interference immunity.
- **Ground the shielding at both ends.** Ground all shielding with large areas (low impedance), with metalized connector housings or shield connection clamps wherever possible. For cables entering a cabinet, connect shields on all 360° of the cable. Never connect a simple “pigtail.” For more information on shielding concepts, (→ # 59).
- **With separate mains filter, maintain separation of leads entering and exiting the mains filter (line power filter).** Locate the filter as close as possible to the point where the incoming power enters the cabinet. If it is necessary for input power and motor leads to cross, cross them at 90°.
- **Observe cable length limits.** Maximum distance for unshielded I/O lines is 3 m inside the cabinet. If the I/O cable leaves the cabinet, it must be EMC shielded.
- **Feedback lines and Hybrid Cables may not be extended, since the shielding would be interrupted and the signal processing may be disturbed.** Install all feedback cables with an adequate cross-section, per IEC 60204 (→ # 55) and use the requested cable material to reach maximum cable length.
- **Splice cables properly.** If you need to divide cables, use connectors with metal backshells. Ensure that both shells connect along the full 360° of the shields.
- **Use differential inputs for analog signals.** Noise susceptibility in analog signals is greatly reduced by using differential inputs. Use twisted-pair, shielded signal lines, connecting shields on both ends.
- **Cables between drives and filters or external regen resistors must be shielded.** Install all power cables with an adequate cross-section per IEC 60204 (→ # 55) and use the requested cable material to reach maximum cable length.



### 8.4.2 Shielding with external shielding busbar

For best practice use of shielded cables Kollmorgen recommends a star point shield connection, for example, with a shielding busbar.

#### 8.4.2.1 Shielding Concept

Example with AKD2G-Sxx--6Vxx, EMC filter and external regen resistor.

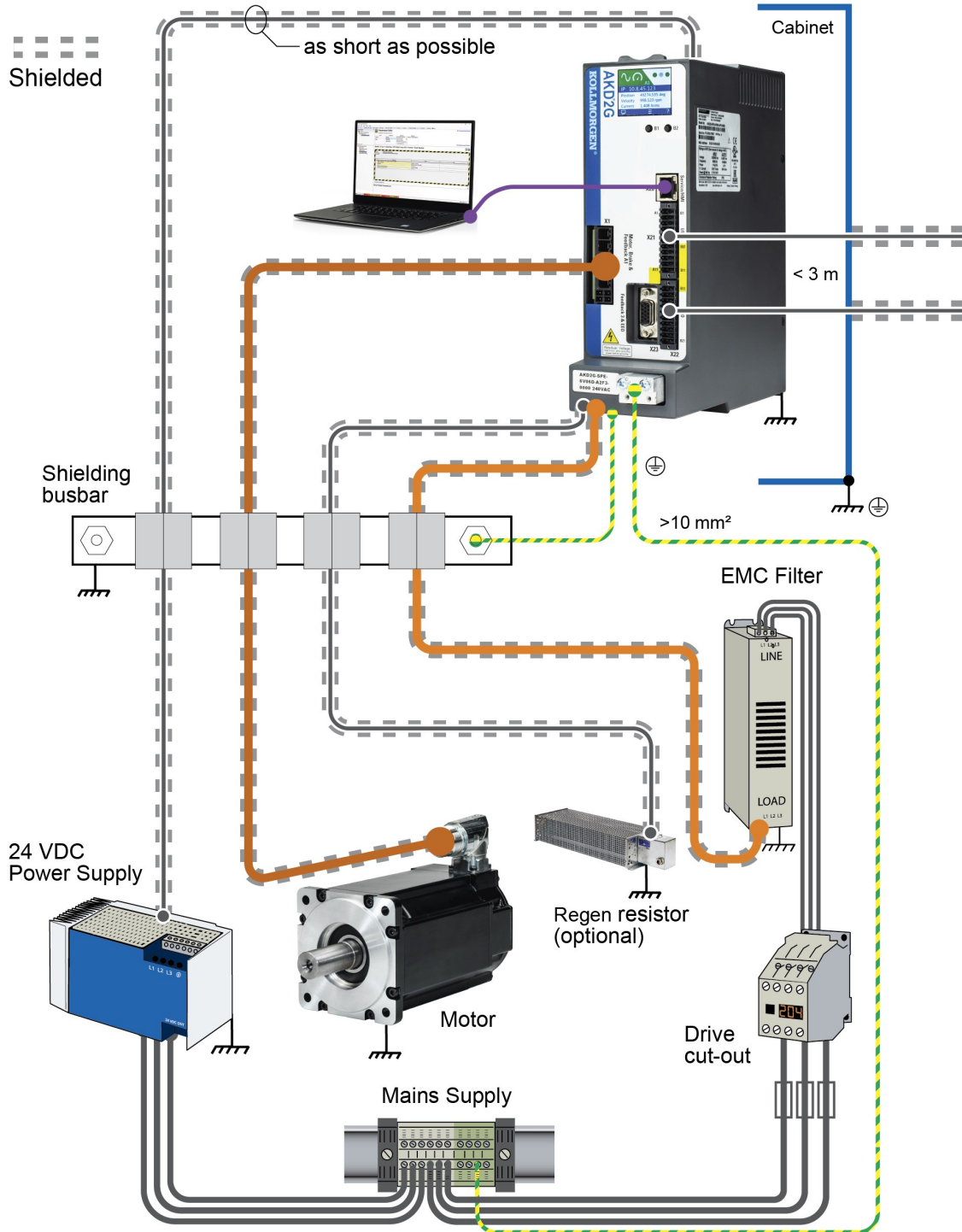

### 8.4.2.2 Shielding Busbar



The power cable shields (line in, motor cable, external regen resistor) can be routed to an additional busbar via shield clamps.

Kollmorgen recommends using Weidmüller KLBÜ shield clamps.

A possible scenario for setting up a busbar for the above shield clamps is described below.

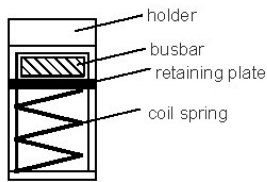
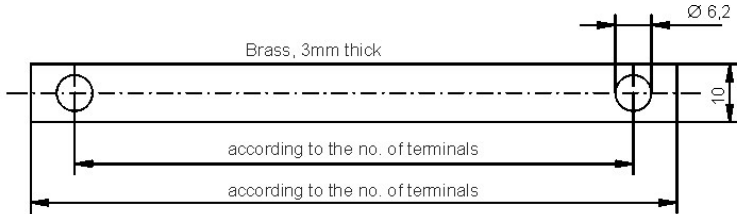

1. Cut a busbar of the required length from a brass rail (cross-section 10 x 3 mm) and drill holes in it as indicated. All shield clamps required must fit between the drill holes.

#### **CAUTION**

Risk of injury due to the spring force of the coil spring.  
Use pliers.

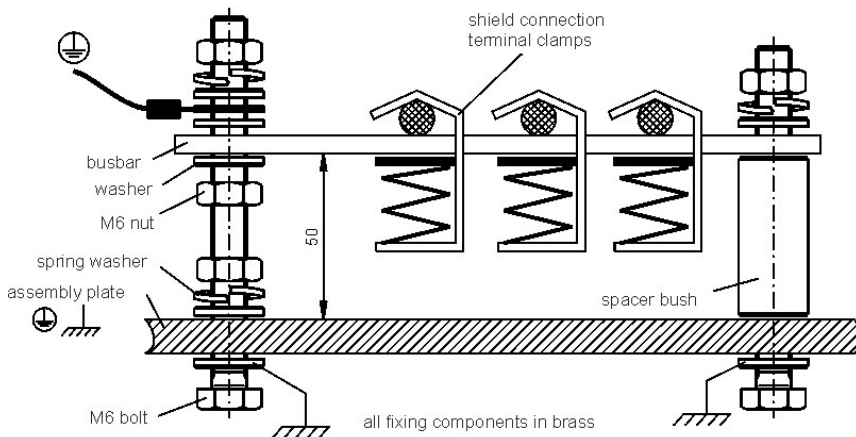

2. Squeeze together the coil spring and the supporting plate and push the busbar through the opening in the holder.
3. Mount the busbar with the shield clamps fitted on the assembly plate. Use either metal spacer bushes or screws with nuts and accessories to maintain a spacing of 50 mm. Earth the busbar using a single conductor with a cross-section of at least 2.5 mm<sup>2</sup>.
4. Strip the external cable sheath to a length of approx. 30 mm, taking care not to damage the braided shield. Push the shield clamp up and route the cable to it via the busbar.

#### **NOTICE**

Make sure there is good contact between the shield clamp and the braided shield.

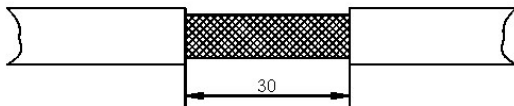

### 8.4.3 Shielding connection to the drive

You can connect cable shielding directly to the drive by using grounding plates, shield connection clamps, and a motor connector with strain relief and grounding plate.

#### 8.4.3.1 Shielding Concept

Example with AKD2G-Sxx--7Vxx, dual-axis.

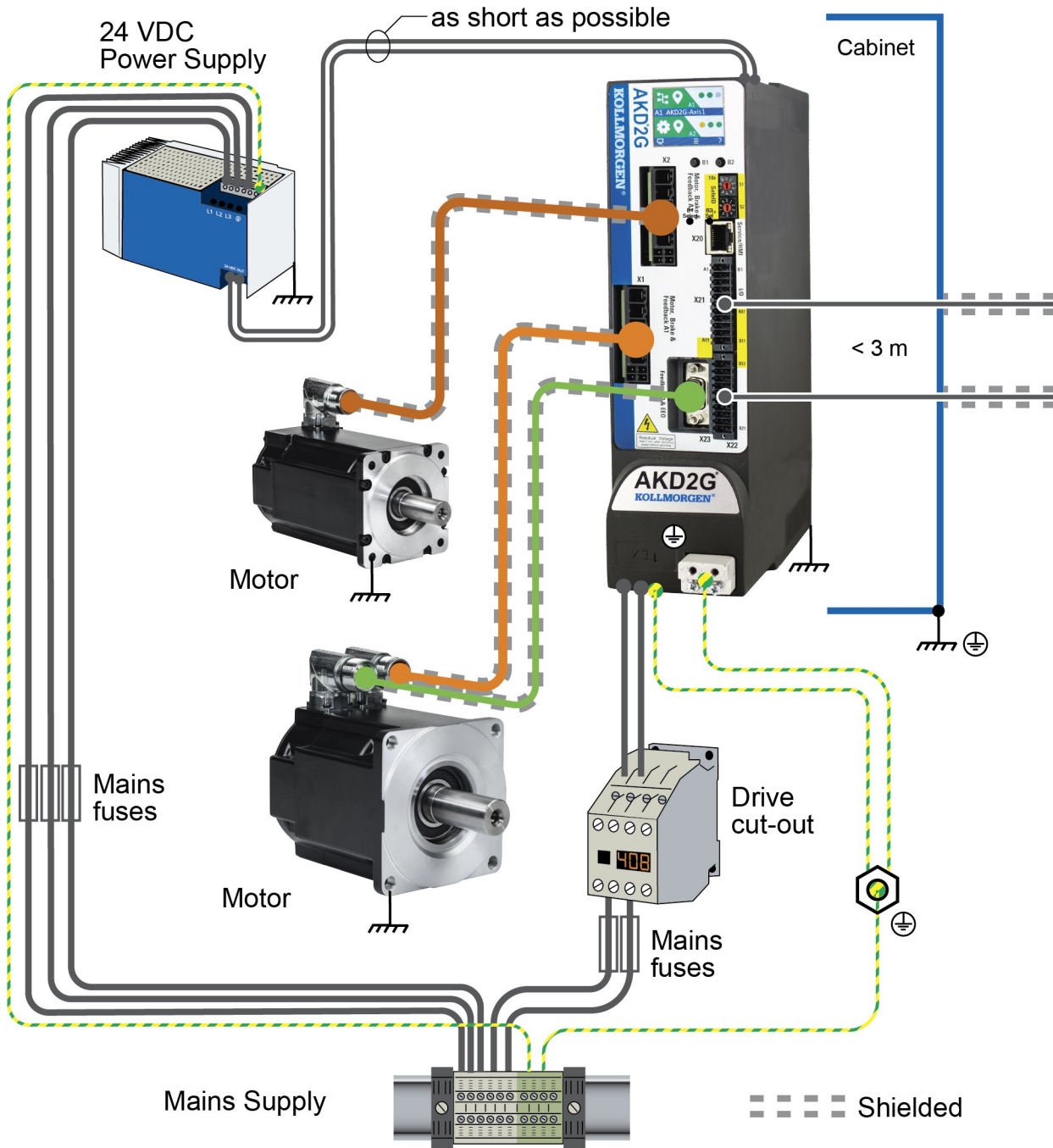

### 8.4.3.2 Grounding plates and shield connection clamps

A grounding plate is mounted to the drive.



Use shield connection clamps (see accessories manual). These hook into the grounding plate and ensure optimum contact between the shield and the grounding plate.

Kollmorgen recommends using Phoenix Contact SK14 shield clamps with cable clamp range of 6-13mm.



### 8.4.3.3 Motor connector X1/X2 with shielding connection

Alternative connection of the motor power by mating connector with shield plate and strain relief. Kollmorgen motor power and hybrid motor cables are configured with shield plate.

To connect the motor power, proceed as follows:

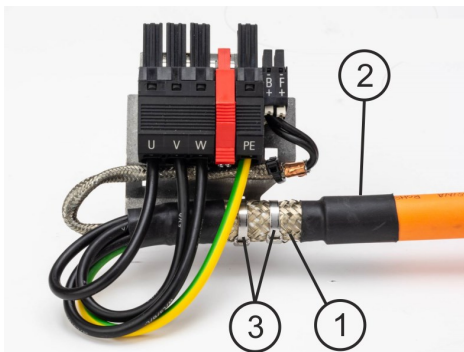

1. Strip the external cable sheath to a length of approx. 80mm, taking care not to damage the braided shield.
2. Push the braided shield (1) back over the cable and secure with a rubber sleeve (2) or shrink sleeve.
3. Shorten all the wires apart from the protective earth (PE) wire (green/yellow) by about 20mm so that the PE wire is now the longest wire.
4. Strip all wires and fit wire end ferrules.
5. Secure the braided shield of the cable with metal cable ties (3) and fasten the cable.
6. Wire the connector as shown in the connection diagram.
7. Plug in the connector to the socket on the front of the AKD2G and secure it with the red clip.

The motor power is now connected.

## 8.5 Connection Overview

### 8.5.1 Connector Position AKD2G-Sxx-6V

**NOTE**

The graphics shows an AKD2G with supply voltage 110 V to 240 V.  
 X2 is available with dual-axis drives only.  
 Optional: I/O, F3 or DX (→ # 28).

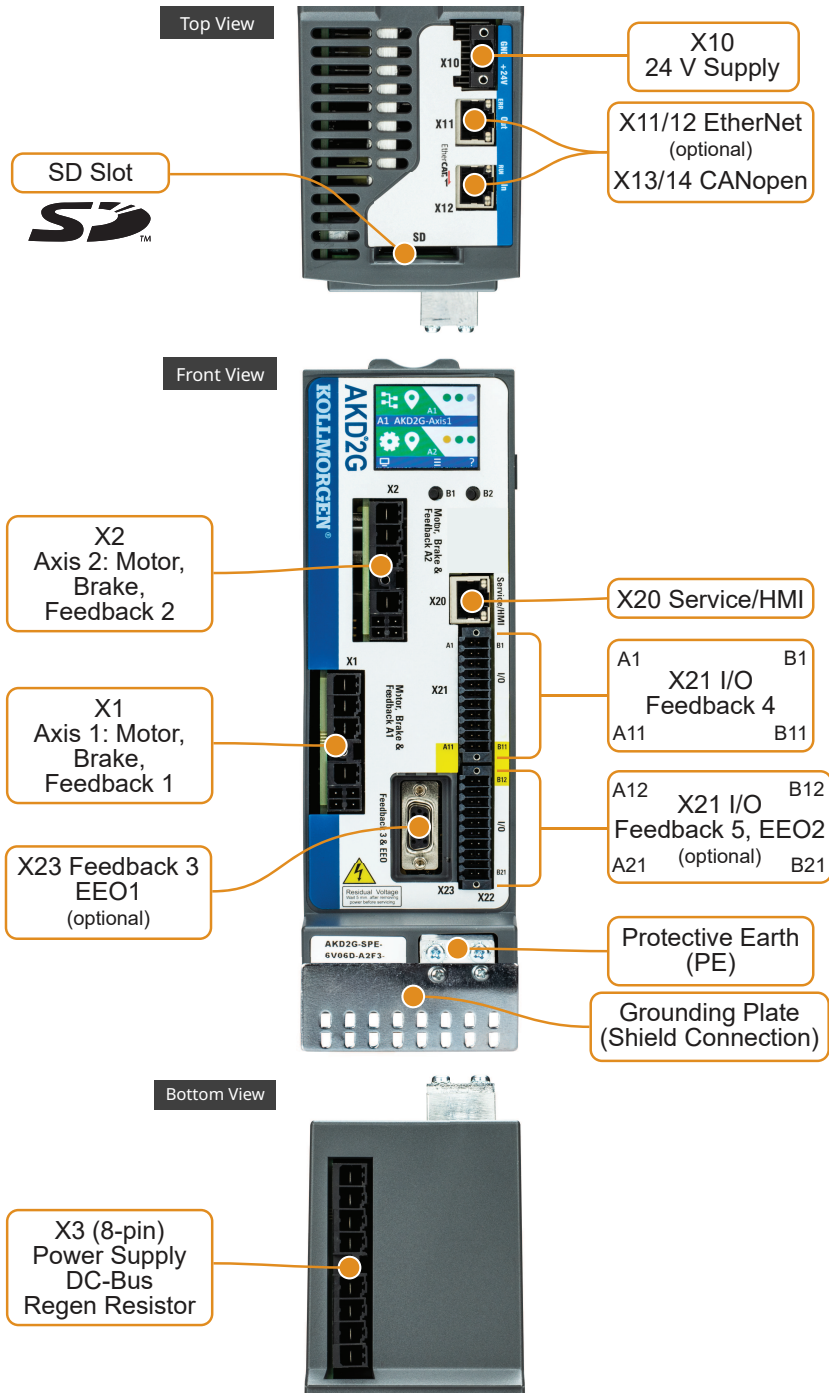

### 8.5.2 Connector Position AKD2G-Sxx-7V

**NOTE**

The graphics shows an AKD2G with supply voltage 240 V to 480 V.  
 X2 is available with dual-axis drives only.  
 Optional: I/O, F3 or DX (→ # 28).

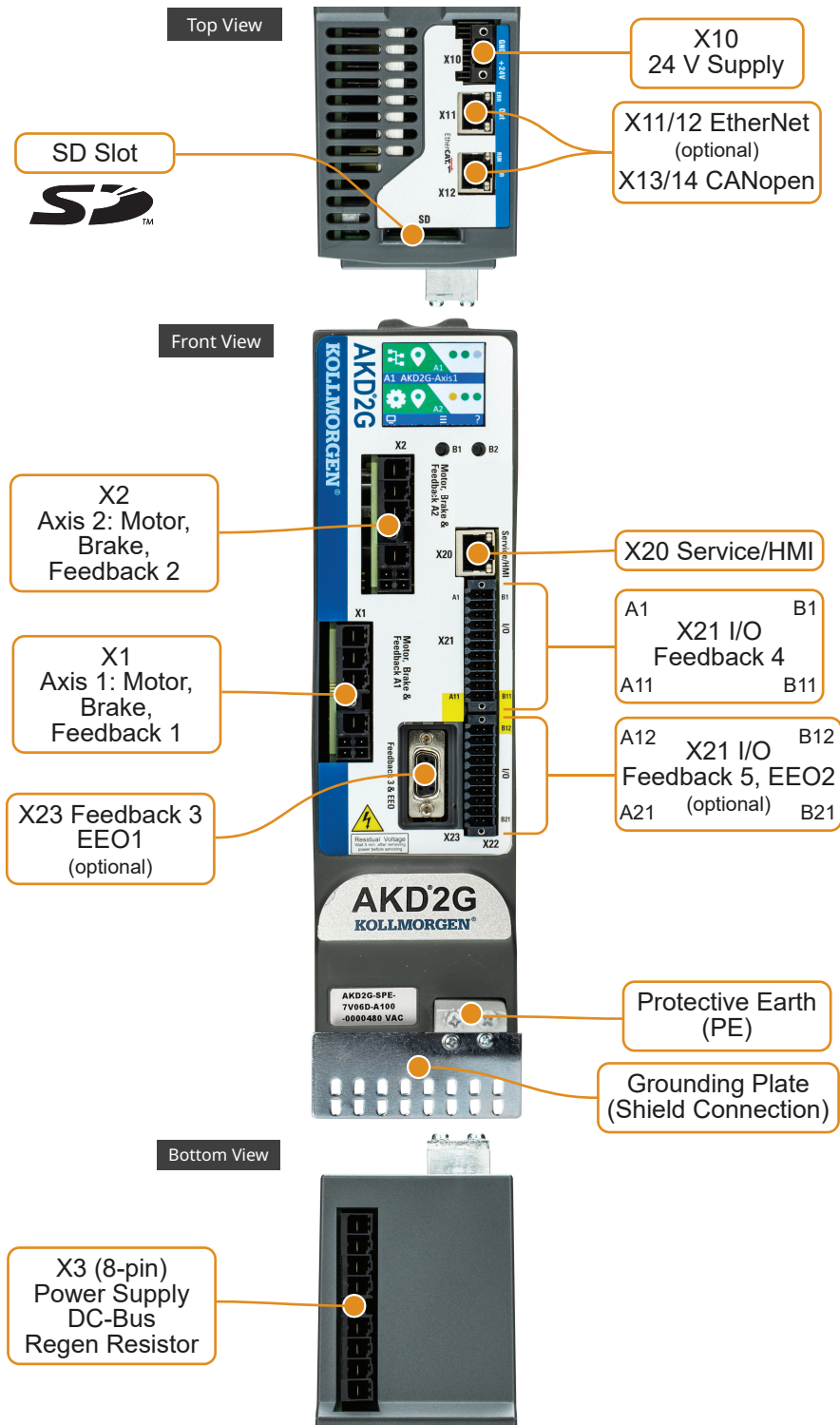



### 8.5.2.1 AKD2G 480 Vac, 24 Amp drive

**NOTE** The graphics shows an AKD2G with supply voltage 480 V.  
Optional: I/O, F3 or DX (→ # 28).

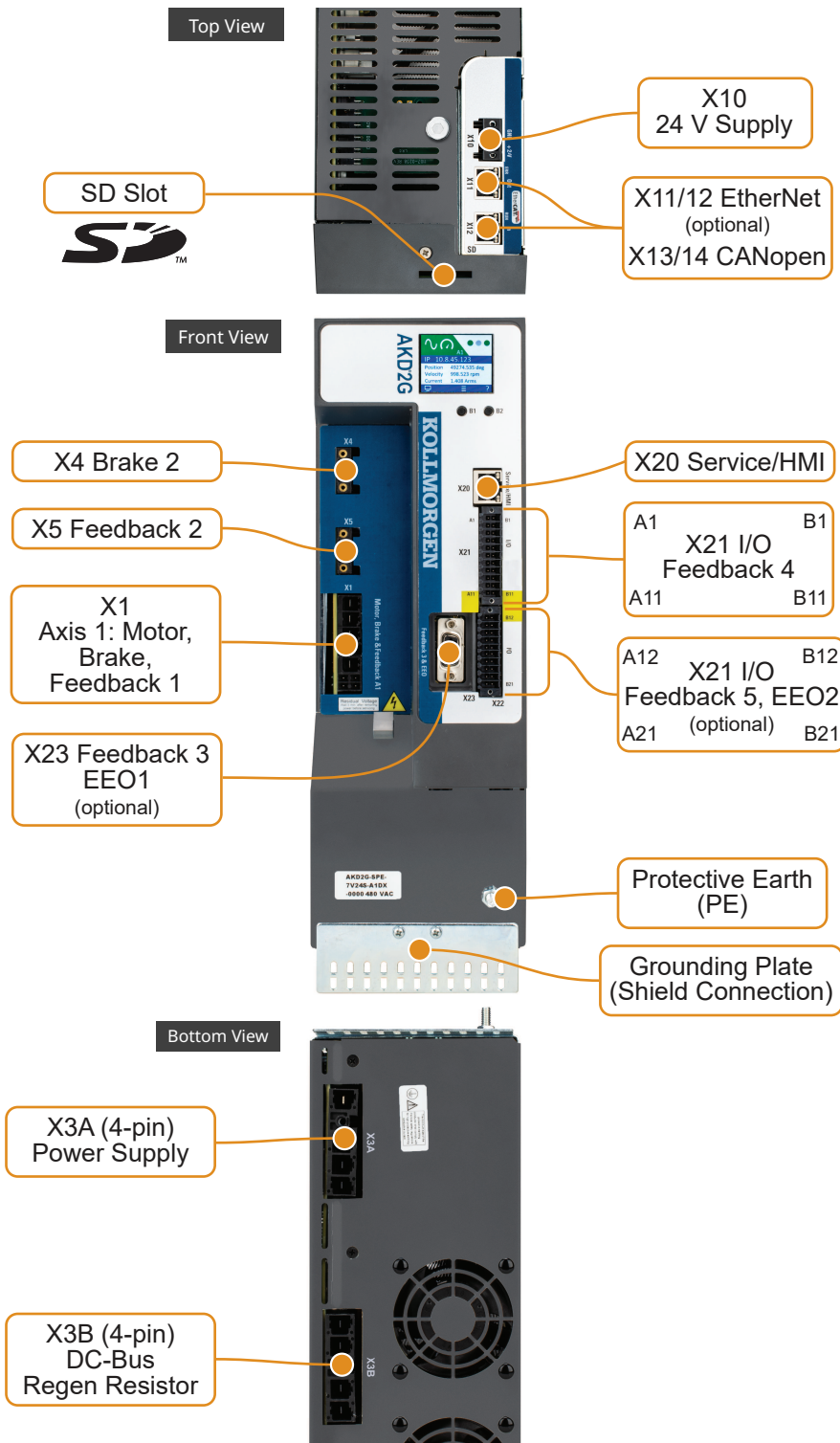

### 8.5.3 Wiring overview, single axis drive

#### AKD2G Sxx-xxS 3-12 Amp Drives

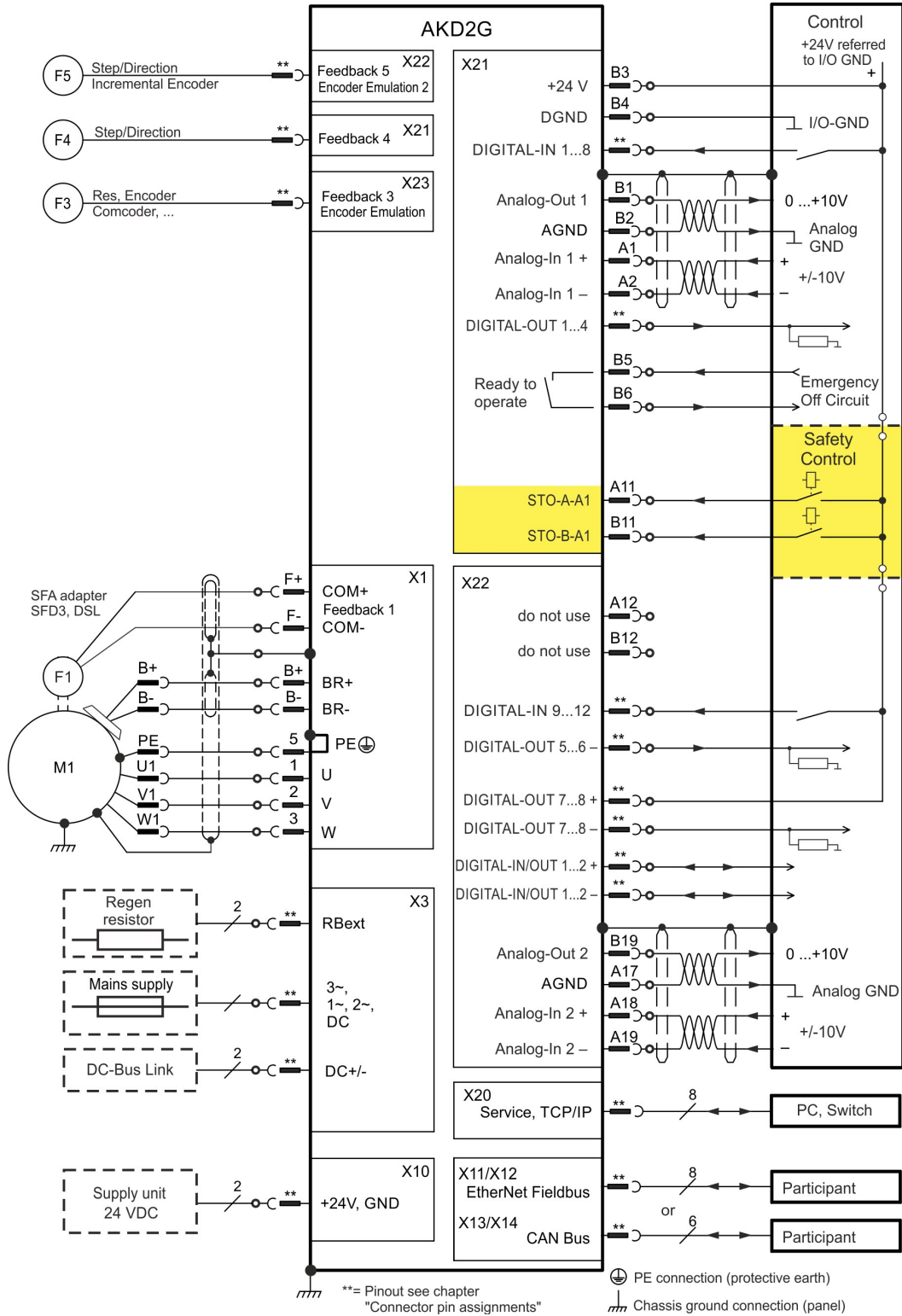



AKD2G Sxx-724S 24 Amp Drives

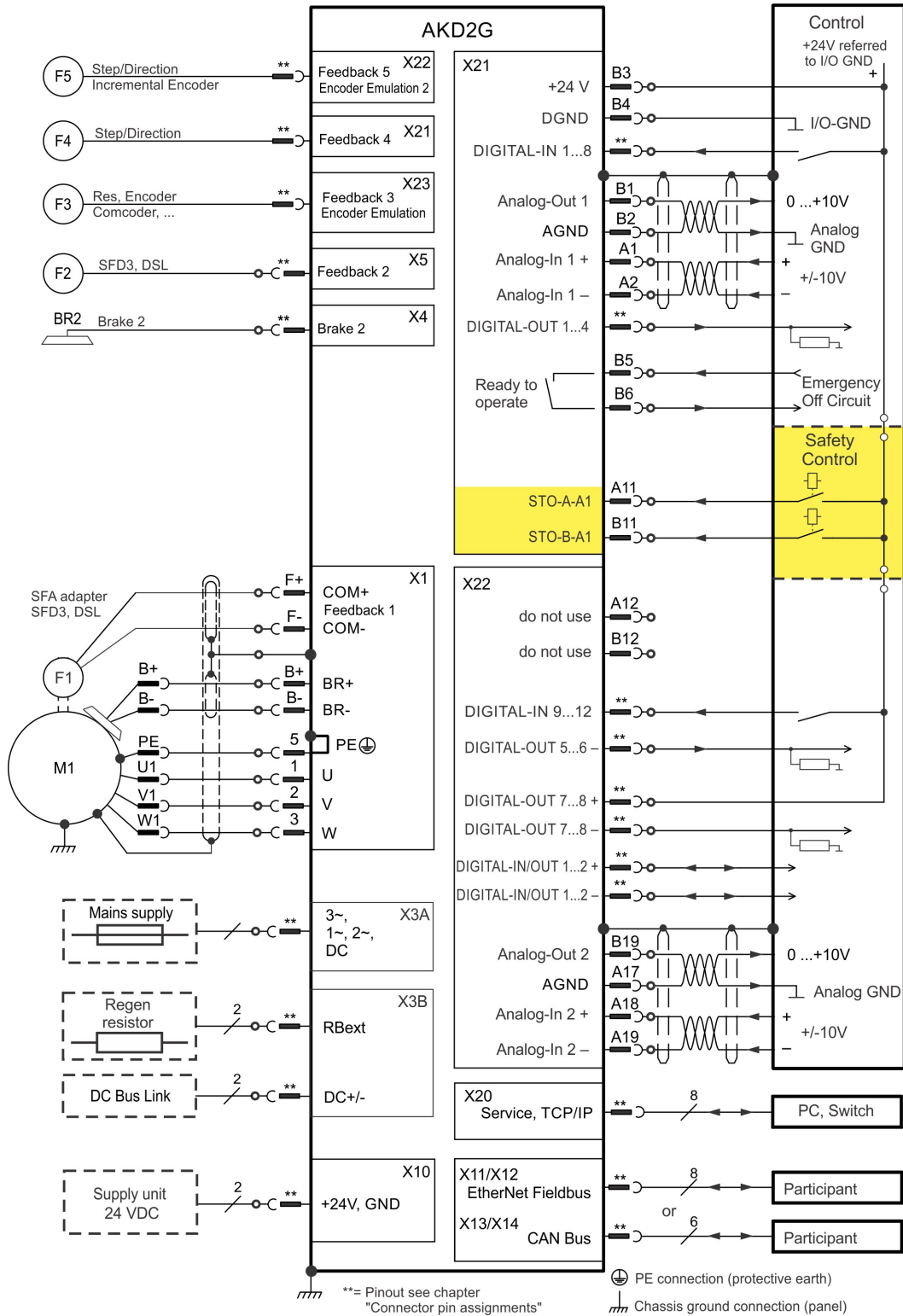

### 8.5.4 Wiring overview, dual axis drive

#### AKD2G Sxx-xxS 3-12 Amp Drives

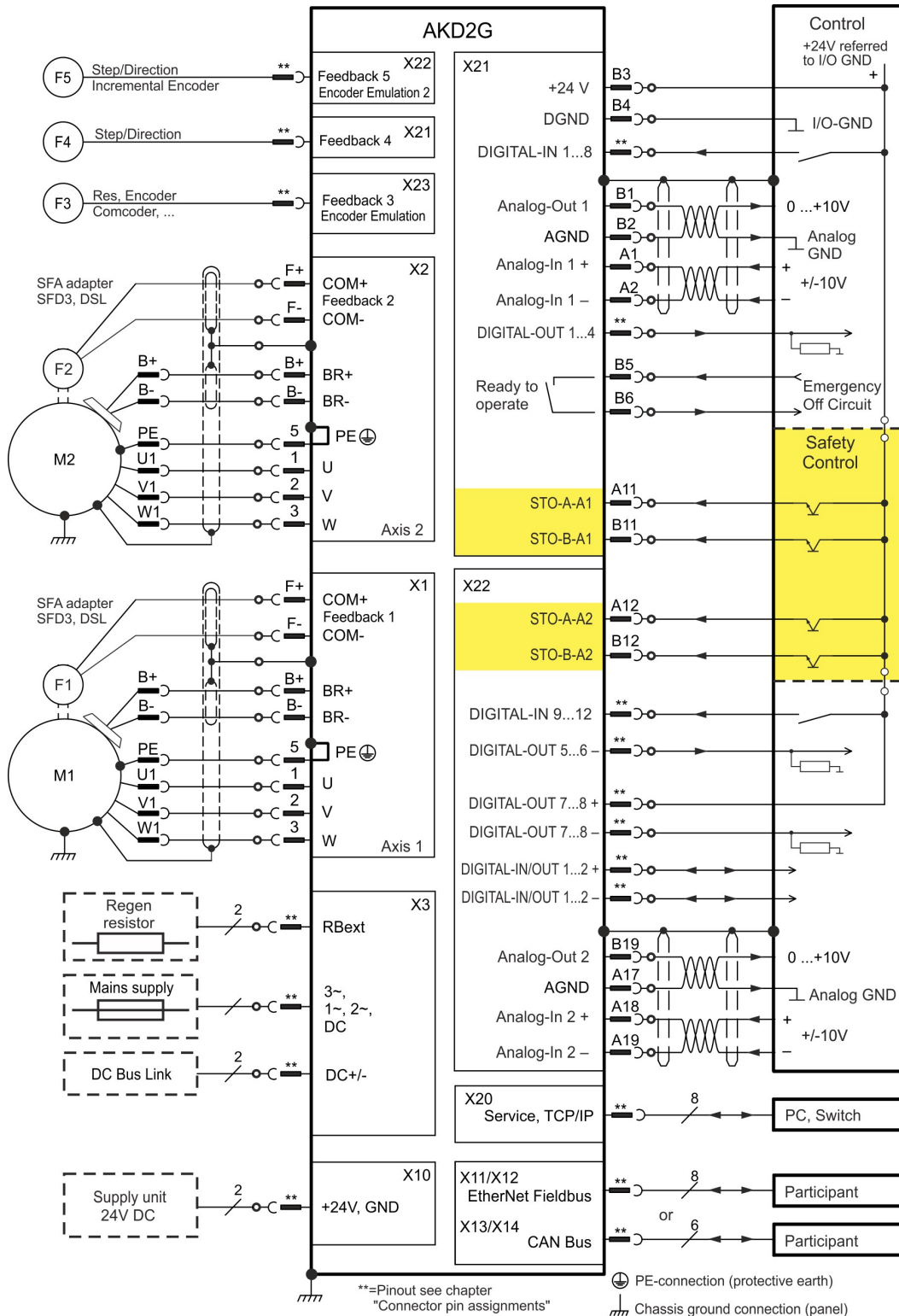

## 8.5.5 Connector pinout

Information to wiring, mating connectors and cables (→ # 54).

### 8.5.5.1 X1 and X2: Motor, Brake, Feedback 1

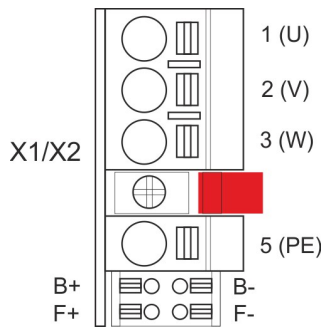

- 4 pin, pitch 7.62 mm plus 2x2 pin pitch 3.81 mm
- Spring clamps
- Locking screw, tightening torque 0.5 Nm (4.4 inlbs)
- Motor power, Motor brake (X1: axis 1, X2: axis 2)
- X1: Input for commutation feedback 1 (→ # 106)
- X2: Input for commutation feedback 2 (→ # 106)
- Wiring example:
  - DC Bus link (→ # 92)
  - Motor single cable connection (→ # 97)
  - Motor dual cable connection (→ # 99)

Pin	Label	Signal	Description
1	U	U	Motor phase U
2	V	V	Motor phase V
3	W	W	Motor phase W
retention latch, shield screw			
5	PE	PE	Protective earth
B+	B+	BR+	Motor holding brake +
B-	B-	BR-	Motor holding brake -
F+	F+	COM+	SFD3 + or HIPERFACE DSL +
F-	F-	COM-	SFD3 - or HIPERFACE DSL -

### 8.5.5.2 X3: Mains, regen resistor, DC-Bus

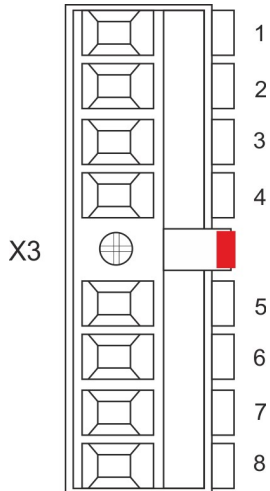

- 8 pin, pitch 7.62 mm
- Screw terminals, tightening torque 0.5 to 0.6 Nm (4.4 to 5.3 in-lbs)
- Locking screw, tightening torque 0.5 Nm (4.4 in-lbs)
- Optional T version
- Mains supply, external regen resistor, DC-Bus
- X3/5 to X3/6 must be shorted to use the built-in regen resistor. Remove the jumper to connect an external regen resistor.
- Wiring example:
  - Power supply (→ # 80)
  - DC Bus link (→ # 92)
  - External regen resistor (→ # 95)

Pin	Label	Signal	Description
1	PE	PE	Protective earth
2	R	L1	3~ mains supply L1, 1~ supply L, DC supply +
3	S	L2	3~ mains supply L2
4	T	L3	3~ mains supply L3, 1~ supply N, DC supply -
5	Ri	RBint	internal regen resistor
6	RE	-RB	external regen resistor -
7	+DC	+DC (+RBext)	DC Bus link+ and/or external regen resistor +
8	-DC	-DC	DC Bus link -

### 8.5.5.3 X3A/X3B: Mains, regen resistor, DC-Bus

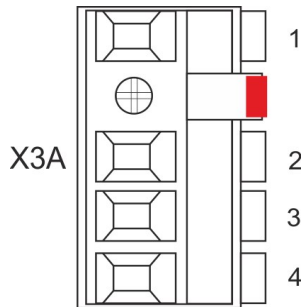

- 2x 4 pin, pitch 10.16 mm
- Screw terminals, tightening torque 2 Nm (18 in-lbs)
- Mains supply, external regen resistor, DC-Bus
- X3A/5 to X3B/6 must be shorted to use the built-in regen resistor. Remove the jumper to connect an external regen resistor.
- Wiring example:
  - Power supply (→ # 80)
  - DC Bus link (→ # 92)
  - External regen resistor (→ # 95)

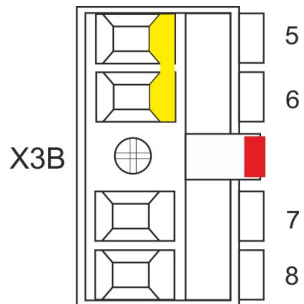

#### X3A

Pin	Label	Signal	Description
1	PE	PE	Protective earth
2	R	L1	3~ mains supply L1, 1~ supply L, DC supply +
3	S	L2	3~ mains supply L2
4	T	L3	3~ mains supply L3, 1~ supply N, DC supply -

#### X3B

Pin	Label	Signal	Description
5	Ri	RBint	internal regen resistor
6	RE	-RB	external regen resistor -
7	+DC	+DC (+RBext)	DC Bus link+ and/or external regen resistor +
8	-DC	-DC	DC Bus link -

### 8.5.5.4 X4: Second Brake

**NOTE** Use with single axis drives and Safety Option 23 for safety functions, which require a second brake.

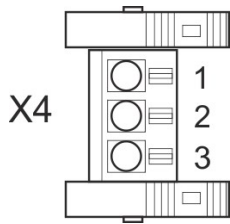

- 3 pin, pitch 3.81 mm
- Spring clamps
- Second motor brake
- Required for SIL3 brake control

Pin	Signal	Description
1	PE	Protective earth
2	BR2-	Second (external) brake -
3	BR2+	Second (external) brake +

### 8.5.5.5 X5: Feedback 2

**NOTE** Use with single axis drives and Safety Option 23 for application, which require a second feedback.

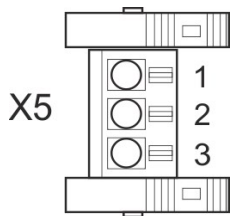

- 3 pin, pitch 3.81 mm
- Spring clamps
- Input for feedback 2 (→ # 107)

Pin	Signal	Description
1	PE	Protective earth
2	COM2-	Second SFD3 - or Second/Safe HIPERFACE DSL -
3	COM2+	Second SFD3 + or Second/Safe HIPERFACE DSL +

### 8.5.5.6 X10: 24 VDC

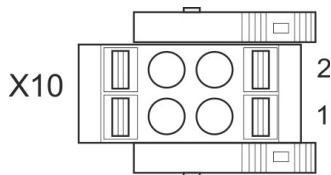

- 2 pin, pitch 5.08 mm
- Spring clamps
- T version
- 24 VDC supply voltage
- Wiring example: (→ # 91)

Pin	Signal	Description
1	+ 24 V	+24 VDC supply voltage, PELV
2	GND	Ground for 24 VDC supply voltage, PELV

**8.5.5.7 X11, X12: EtherNet Fieldbus**

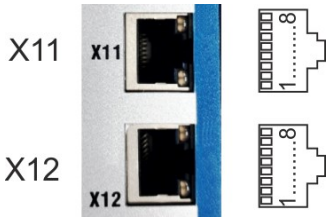

- RJ45 with built-in green/red dual-color LED
- EtherCAT, EtherNet/IP, PROFINET
- Interface Details: (→ # 142)

Pin	Signal	Description	Pin	Signal	Description
1	Tx+	Transmit +	5	Term.	Termination
2	Tx-	Transmit -	6	Rx-	Receive -
3	Rx+	Receive +	7	Term.	Termination
4	Term.	Termination	8	Term.	Termination

**8.5.5.8 X13, X14: CAN bus (optional)**

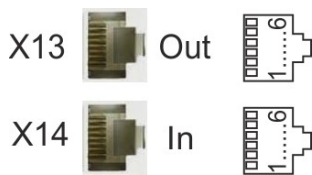

- RJ25
- X14 IN port, X13 OUT port
- Up to 1 Mbit operation
- Node ID to be set by WorkBench
- Interface Details: (→ # 145)

Pin	Signal	Description	Pin	Signal	Description
1	n.c.	not used	4	CAN_low	CAN bus low signal
2	Shield	Chassis	5	CAN_GND	CAN bus ground
3	CAN_high	CAN bus high signal	6	n.c.	not used

**8.5.5.9 X20: Service**

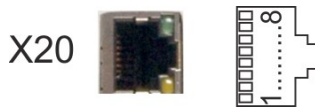

- RJ45 with built-in green and yellow LEDs
- 100/10 Mbit EtherNet TCP/IP, Modbus/TCP
- Supports auto-IP, DHCP and fixed IP addressing
- Supports point-to-point (i.e. Auto-IP) and connection by using network switches
- Supports automatic discovery in WorkBench if in the same sub-net.
- Interface Details: (→ # 148)

Pin	Signal	Description	Pin	Signal	Description
1	Tx+	Transmit +	5	Term.	Termination
2	Tx-	Transmit -	6	Rx-	Receive -
3	Rx+	Receive +	7	Term.	Termination
4	Term.	Termination	8	Term.	Termination

### 8.5.5.10 X21: I/O, Feedback 4

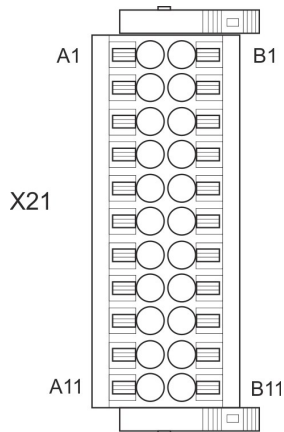

- 2 x 11 pins (left column A, right column B), pitch 3.5 mm
- Spring clamps
- Analog and digital I/O
- Input for feedback 4 (→ # 108)
- Wiring examples:
  - Analog input (→ # 152)
  - Analog output (→ # 153)
  - Digital input (→ # 154)
  - Digital Output (→ # 158)
  - Feedback (→ # 108)

#### Digital I/O connectivity

Pin	Signal	Description
A1	Analog-In (AIN) 1 +	Analog Input +/- 10 V
A2	Analog-In (AIN) 1 -	
A3*	Digital-In (DIN) 1	Fast, isolated, sink, type EN 61131-2 type 1
A4*	Digital-In (DIN) 2	Fast, isolated, sink, type EN 61131-2 type 1
A5	Digital-In (DIN) 3	Slow, isolated, sink, type EN 61131-2 type 1
A6	Digital-In (DIN) 4	Slow, isolated, sink, type EN 61131-2 type 1
A7	Digital-In (DIN) 5	Slow, isolated, sink, type EN 61131-2 type 1
A8	Digital-In (DIN) 6	Slow, isolated, sink, type EN 61131-2 type 1
A9	Digital-In (DIN) 7	Slow, isolated, sink, type EN 61131-2 type 1
A10	Digital-In (DIN) 8	Slow, isolated, sink, type EN 61131-2 type 1
A11	<b>STO-A-A1</b>	Slow, isolated, sink, fail-safe, <b>STO axis 1 channel A</b>
B1	Analog-Out (AOUT) 1	Analog Output, 0 to +10 V
B2	AGND	Ground for analog I/O
B3	+24 V	+24 VDC for digital I/O and STO
B4	DGND	Ground for digital I/O and STO
B5	Digital-Out (DOOUT) 9 +	Relay contact, normally open, 24 VDC, 1A
B6	Digital-Out (DOOUT) 9 -	Relay contact, normally open, 24 VDC, 1A
B7	Digital-Out (DOOUT) 1	Isolated, high-side, 100 mA
B8	Digital-Out (DOOUT) 2	Isolated, high-side, 100 mA
B9	Digital-Out (DOOUT) 3	Isolated, high-side, 100 mA
B10	Digital-Out (DOOUT) 4	Isolated, high-side, 100 mA
B11	<b>STO-B-A1</b>	Slow, isolated, sink, fail-safe, <b>STO axis 1 channel B</b>

#### \*Feedback 4 connectivity, Step/Direction CW/CCW (input)

Pin	Signal	Description
A3	Step, CW	Fast, isolated, sink, type EN 61131-2 type 1
A4	Direction, CCW	Fast, isolated, sink, type EN 61131-2 type 1



### 8.5.5.11 X22: I/O, EEO2, Feedback 5

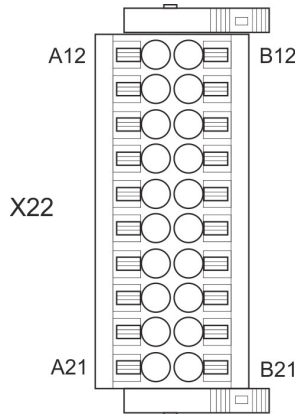

- 2 x 10 pins (left column A, right column B), pitch 3.5 mm
- Spring clamps
- Analog and digital I/O
- Input for feedback 5 (→ # 109)
- Output for incremental encoder emulation (EEO2)
- Wiring examples:
  - Analog input (→ # 152)
  - Analog output (→ # 153)
  - Digital input (→ # 154)
  - Digital output (→ # 158)
  - Feedback (→ # 109)
  - Encoder emulation (EEO2) (→ # 139)
  - Master-Slave (→ # 141)

#### Digital I/O connectivity

Pin	Signal	Description
A12	STO-A-A2	Slow, isolated, sink, fail-safe, STO axis 2 channel A
A13	Digital-In (DIN) 9	Slow, isolated, sink, type EN 61131-2 type 1
A14	Digital-In (DIN) 10	Slow, isolated, sink, type EN 61131-2 type 1
A15	Digital-In (DIN) 11	Slow, isolated, sink, type EN 61131-2 type 1
A16	Digital-In (DIN) 12	Slow, isolated, sink, type EN 61131-2 type 1
A17	AGND	Ground for analog I/O
A18	Analog-In (AIN) 2+	Analog Input, +/- 10 V
A19	Analog-In (AIN) 2-	
A20*	Digital-In/Out (DIO) 1 +	RS485 input or output
A21*	Digital-In/Out (DIO) 1 -	RS485 input or output
B12	STO-B-A2	Slow, isolated, sink, fail-safe, STO axis 2 channel B
B13	Digital-Out (DOOUT) 5	Isolated, high-side, 100 mA
B14	Digital-Out (DOOUT) 6	Isolated, high-side, 100 mA
B15	Digital-Out (DOOUT) 7 +	Fast, isolated, sink or source, 100 mA
B16	Digital-Out (DOOUT) 7 -	
B17	Digital-Out (DOOUT) 8 +	Fast, isolated, sink or source, 100 mA
B18	Digital-Out (DOOUT) 8 -	
B19	Analog-Out (AOUT) 2	Analog Output, 0 to +10 V
B20*	Digital-In/Out (DIO) 2 +	RS485 input or output
B21*	Digital-In/Out (DIO) 2 -	RS485 input or output

#### \*Feedback 5 (input)

#### \*EEO2 (output)

Pin	Increm. Encoder	Step/Dir	CW/CCW	BiSS C EnDAT 2.2	SSI	Pin	Increm. Encoder
A20	Track A +	Step +	CW +	CLK+	CLK+	A20	A+
A21	Track A -	Step -	CW -	CLK-	CLK-	A21	A -
B20	Track B +	Dir +	CCW +	DAT+	DAT+	B20	B+
B21	Track B -	Dir -	CCW -	DAT-	DAT-	B21	B -

**8.5.5.12 X23: I/O, EEO1, Feedback 3**

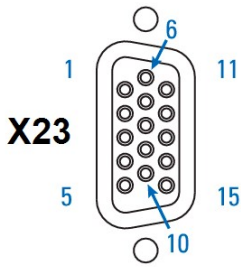

- Sub-D high density 15 pin, female
- Locking screws, tightening torque 0.4 Nm (3.5 inlbs)
- Input for feedback 3 (→ # 110)
- Output for incremental encoder emulation (EEO1)
- Additional Digital-In/Out
- Wiring examples:
  - Feedback (→ # 110)
  - Encoder emulation (EEO1) (→ # 140)
  - Master-Slave (→ # 141)
  - Digital input (→ # 154)
  - Digital output (→ # 158)

**Feedback 3 connectivity (input)**

Pin	SFD	Resolver	BiSS		EnDat		HIPERFACE	Sin/ Cos	Sin/ Cos +Hall	Incr. Enc.	Incr. Enc. +Hall	Hall	SSI	Step/ Dir	CW/ CCW
			B	C	2.1	2.2									
1	-	-	-	-	-	-	-	-	Hall U	-	Hall U	Hall U	-	-	-
2	-	-	CL+	CL+	CL+	CL+	-	-	Hall V	-	Hall V	Hall V	CL+	-	-
3	-	-	CL-	CL-	CL-	CL-	-	-	Hall W	-	Hall W	Hall W	CL-	-	-
4	S+	-	S+	S+	S+	S+	S+	S+	S+	S+	S+	-	-	-	-
5	S-	-	S-	S-	S-	S-	S-	S-	S-	S-	S-	-	-	-	-
6	COM+	R1 Ref+	D+	D+	D+	D+	D+	Z+	Z+	Z+	Z+	-	D+	-	-
7	COM-	R2 Ref-	D-	D-	D-	D-	D-	Z-	Z-	Z-	Z-	-	D-	-	-
8	-	Th+	Th+	-	Th+	-	Th+	Th+	Th+	Th+	Th+	Th+	Th+	Th+	Th+
9	-	Th-	Th-	-	Th-	-	Th-	Th-	Th-	Th-	Th-	Th-	Th-	Th-	Th-
10	+5 V	-	+5 V	+5 V	+5 V	+5 V	8 to 9 V	+5 V	+5 V	+5 V	+5 V	+5 V	+5 V	+5 V	+5 V
11	0 V	-	0 V	0 V	0 V	0 V	0 V	0 V	0 V	0 V	0 V	0 V	0 V	0 V	0 V
12	-	S1 SIN+	A+	-	A+	-	SIN+	A+	SIN+	A+	A+	-	-	Step+	CW+
13	-	S3 SIN-	A-	-	A-	-	SIN-	A-	SIN-	A-	A-	-	-	Step-	CW-
14	-	S2 COS+	B+	-	B+	-	COS+	B+	COS+	B+	B+	-	-	Dir+	CCW+
15	-	S4 COS-	B-	-	B-	-	COS-	B-	COS-	B-	B-	-	-	Dir-	CCW-

CL = CLOCK, D = DATA, S = SENSE, Th = Thermal control, Z = Zero

  = DC Terminated, can be overridden with [DIO#.TERM](#)

  = Optional

**EEO1 connectivity (output)**

Pin	Incremental Encoder
6	Zero+
7	Zero-
11	0 V
12	A +
13	A-
14	B+
15	B-

**Digital I/O connectivity**

Pin	Digital I/O
2	Digital-In/Out 6 +
3	Digital-In/Out 6 -
6	Digital-In/Out 5 +
7	Digital-In/Out 5 -
10	+5 V
11	0 V
12	Digital-In/Out 3 +
13	Digital-In/Out 3 -
14	Digital-In/Out 4 +
15	Digital-In/Out 4 -

**8.5.5.13 X41: SFA Feedback converter, EEO3/EEO4 EXX3/EXX4 (accessory)**

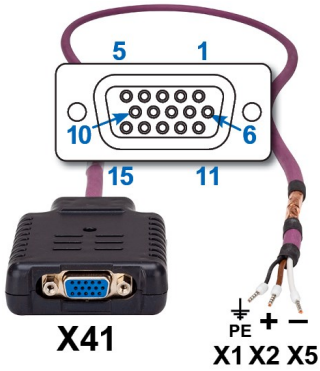

- Sub-D high density 15 pin, female
- Locking screws, tightening torque 0.4 Nm (3.5 in•lbs)
- 1 m cable, 3 flying leads with ferrules for connection to X1, X2, X5 (only on 24 A model)
- Input for electronic gearing
- When connected to X1: Input for feedback 1 (→ # 104)
- When connected to X2: Input for feedback 2 (→ # 104)
- When connected to X5 (only on 24 A model): Input for feedback 2 (→ # 104)
- Output for incremental encoder emulation (EEO3 / EEO4)(EXX3 / EXX4) (→ # 139) - Only available on "-EXX" (Encoder) models
- SFA adapter converts conventional feedback signals to 2 wire feedback format
- Wiring examples:
  - Feedback and Encoder emulation (→ # 125)
  - Master-Slave (→ # 141)

**Feedback 1/2 connectivity (input)**

X41 Pin	SFD	Resolver (1)	BiSS		EnDat		HIPEFACE	Sin / Cos	Sin / Cos +Hall	Incr. Enc.	Incr. Enc. +Hall	Hall	SSI
			B	C	2.1	2.2							
1	-	-	-	-	-	-	-	-	Hall U	-	Hall U	Hall U	-
2	-	-	CL+	CL+	CL+	CL+	-	-	Hall V	-	Hall V	Hall V	CL+
3	-	-	CL-	CL-	CL-	CL-	-	-	Hall W	-	Hall W	Hall W	CL-
4	S+	-	S+	S+	S+	S+	S+	S+	S+	S+	S+	-	-
5	S-	-	S-	S-	S-	S-	S-	S-	S-	S-	S-	-	-
6	COM+	R1 Ref+	D+	D+	D+	D+	D+	Z+	Z+	Z+	Z+	-	D+
7	COM-	R2 Ref-	D-	D-	D-	D-	D-	Z-	Z-	Z-	Z-	-	D-
8	-	Th+	Th+	-	Th+	-	Th+	Th+	Th+	Th+	Th+	Th+	Th+
9	-	Th-	Th-	-	Th-	-	Th-	Th-	Th-	Th-	Th-	Th-	Th-
10	+5 V	-	+5 V	+5 V	+5 V	+5 V	8 to 9 V	+5 V	+5 V	+5 V	+5 V	+5 V	+5 V
11	0 V	-	0 V	0 V	0 V	0 V	0 V	0 V	0 V	0 V	0 V	0 V	0 V
12	-	S1 SIN+	A+	-	A+	-	SIN+	A+	SIN+	A+	A+	-	-
13	-	S3 SIN-	A-	-	A-	-	SIN-	A-	SIN-	A-	A-	-	-
14	-	S2 COS+	B+	-	B+	-	COS+	B+	COS+	B+	B+	-	-
15	-	S4 COS-	B-	-	B-	-	COS-	B-	COS-	B-	B-	-	-

CL = CLOCK, D = DATA, S = SENSE, Th = Thermal control, Z = Zero

(1) : Resolver with AKD2G-CON-SFA-R00 only, all other feedback devices with AKD2G-CON-SFA-E00 only

■ = DC Terminated, can be overridden with [DIO#.TERM](#)

■ = Optional

**EEO3 / EEO4 Connectivity (output)**

X41 Pin	Incremental Encoder
6	Zero+
7	Zero-
11	0 V
12	A +
13	A -
14	B+
15	B-

## 8.6 Power and Logic Voltage Supply (X3/X10)

### 8.6.1 Electrical Supply Connection

#### 8.6.1.1 Connection to various mains supply networks AKD2G-Sxx-6V (100V to 240V)

**NOTICE**

An isolating transformer is required for 400 to 480V networks to get a maximum voltage of 240V +10%.

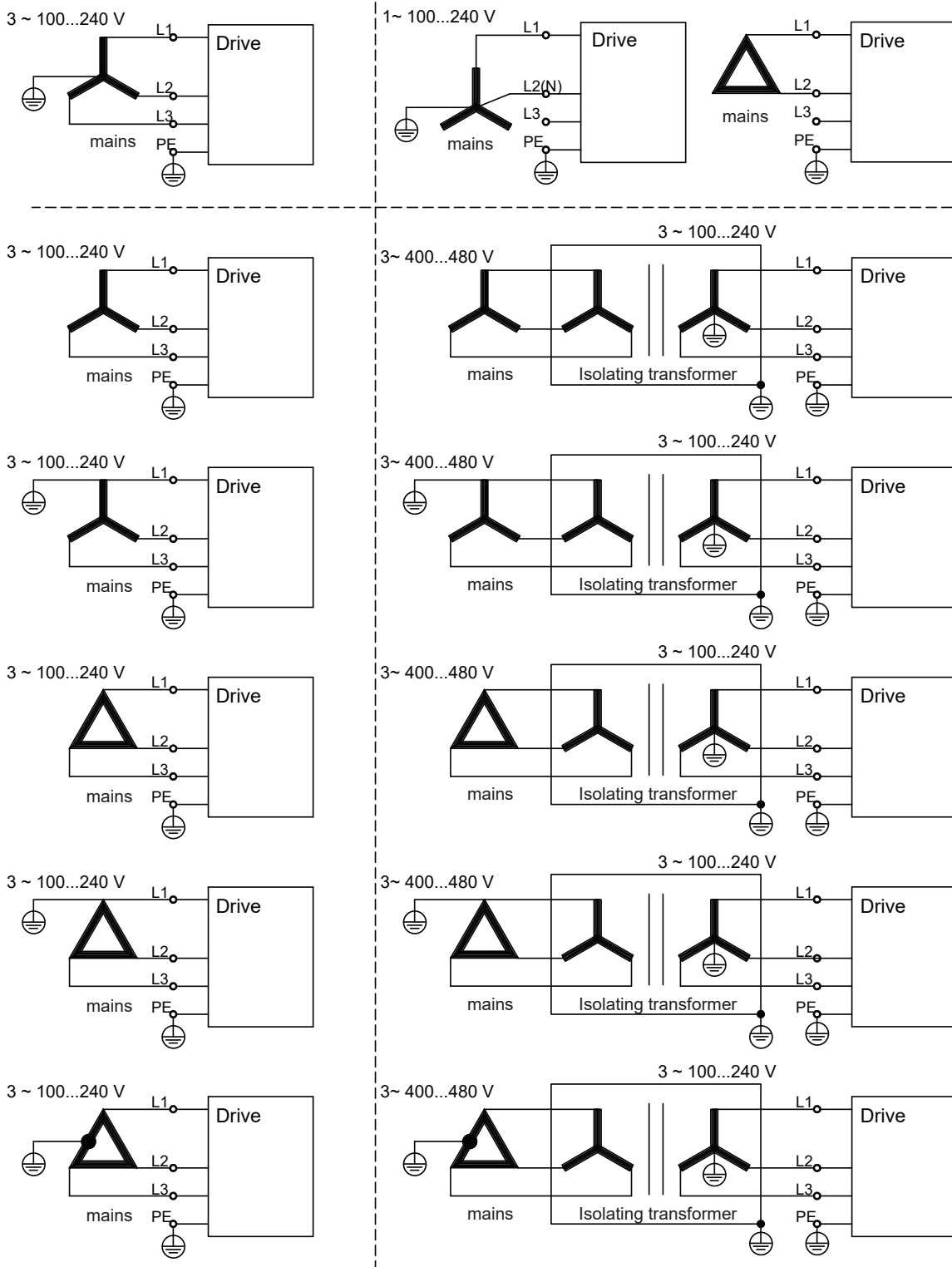

8.6.1.2 Connection to various mains supply networks AKD2G-Sxx-7V (240V to 480V)

**NOTICE**

An isolating transformer is required for 120V networks to get a minimum voltage of 240V +10%.

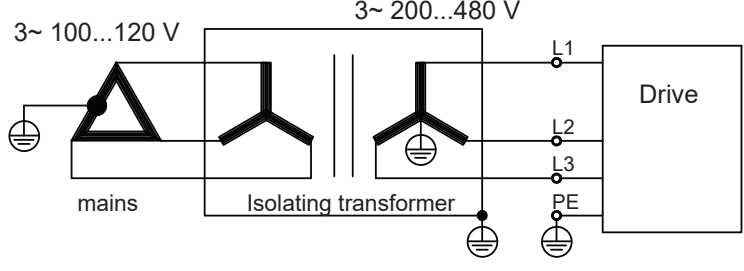
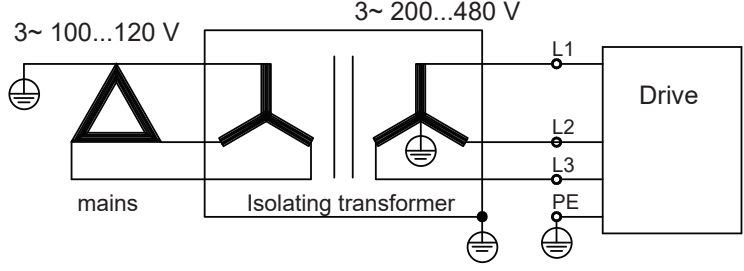
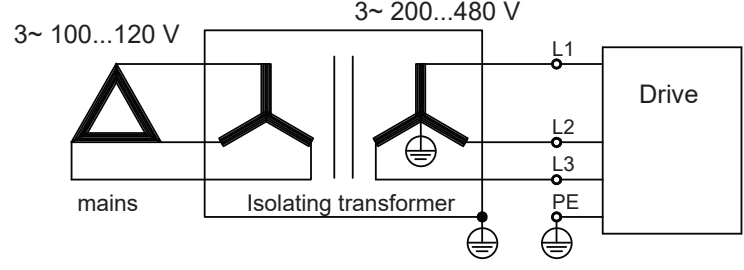
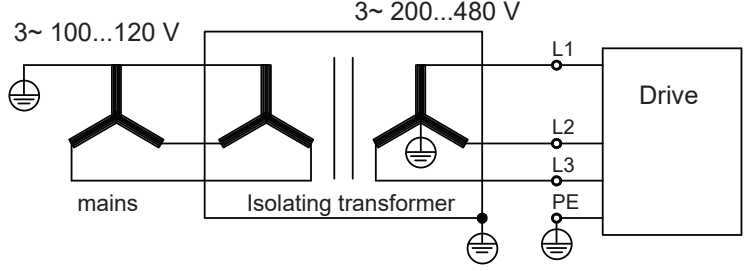
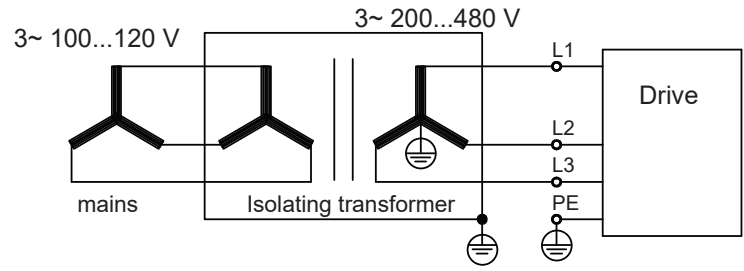
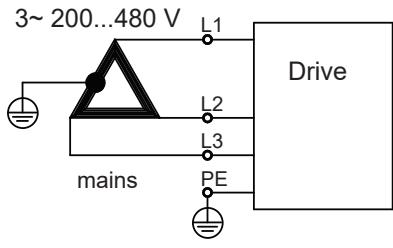
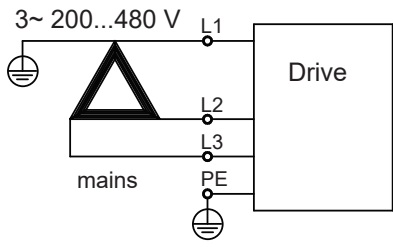
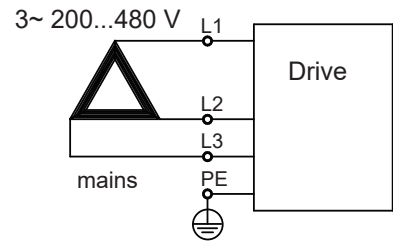
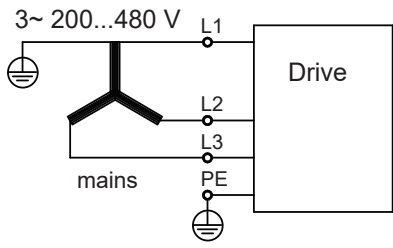
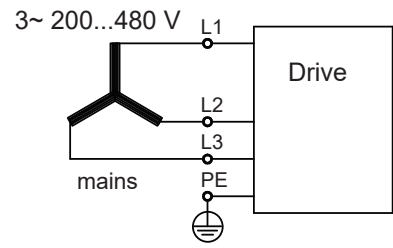
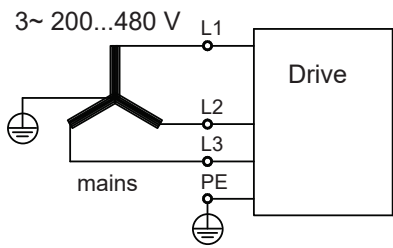

### 8.6.2 Mains power supply connector X3/X3A

Drives in the AKD2G series can be supplied as follows:

#### AKD2G-Sxx-6V

- 1, 2 or 3 phase industrial AC supply networks (TN-S or TT, see [KDN](#)): (→ # 35)
- DC supply networks: (→ # 35)

#### AKD2G-Sxx-7V

- 3 phase industrial AC supply networks (TN-S or TT, see [KDN](#)): (→ # 37)
- DC supply networks: (→ # 37)

For connection to corner grounded delta supply networks contact Kollmorgen customer support.

Periodic overvoltages between phases (L1, L2, L3) and the PE/housing of the drive must not exceed 1,000 V peak. In accordance with IEC 61800, voltage spikes (< 50 µs) between phases must not exceed 1,000 V. Voltage spikes (< 50 µs) between a phase and the PE/housing must not exceed 2,000 V.

- 8/4 pin, pitch 7.62/10.16 mm
- optional T version
- Wiring example:
  - 1 phase AC supply (→ # 81)
  - 2 phase AC supply (→ # 81)
  - 3 phase AC supply (→ # 82)
  - DC supply (→ # 83)
- AKD2G-Sxx-6V requires external EMC filter for use in industrial environment, product category C.
- Mating connector data (→ # 54)
- Fusing with different system structures (→ # 85) ff

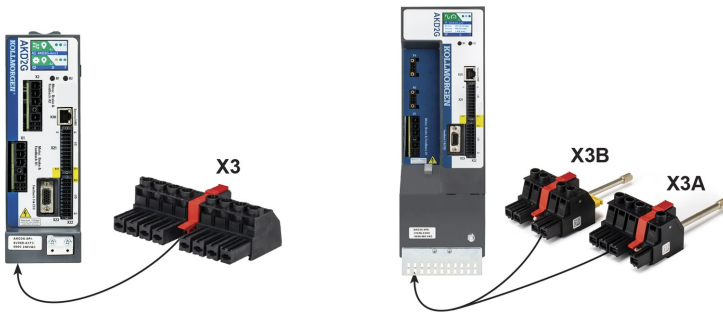

Pin	Label	Signal	1~ Supply	2~Supply	3~ Supply	DC Supply
1	PE	PE	Protective earth	Protective earth	Protective earth	Protective earth
2	R	L1	Phase L1	Phase L1	Phase L1	+ DC
3	S	L2	n.c.	n.c.	Phase L2	n.c.
4	T	L3	Neutral N	Phase L2	Phase L3	- DC

For DC supply: observe notes (→ # 83).

### 8.6.2.1 Wiring examples mains power supply

#### One phase AC mains (AKD2G-Sxx-6V)

- Directly to one phase supply network with neutral line.
- Activate single phase supply (VBUS.THREEPHASE = 0).
- Set VBUS.ACNOMINAL to desired nominal AC line voltage for lines other than nominal rated VAC.
- For complete information refer to WorkBench online help, AKD2G-S User Manual, section Power Setting.
- AC line filtering to be provided by the user. Use filter type FN2090, refer to the *Accessories Manual* for more information. Use shielded cable between filter and drive.

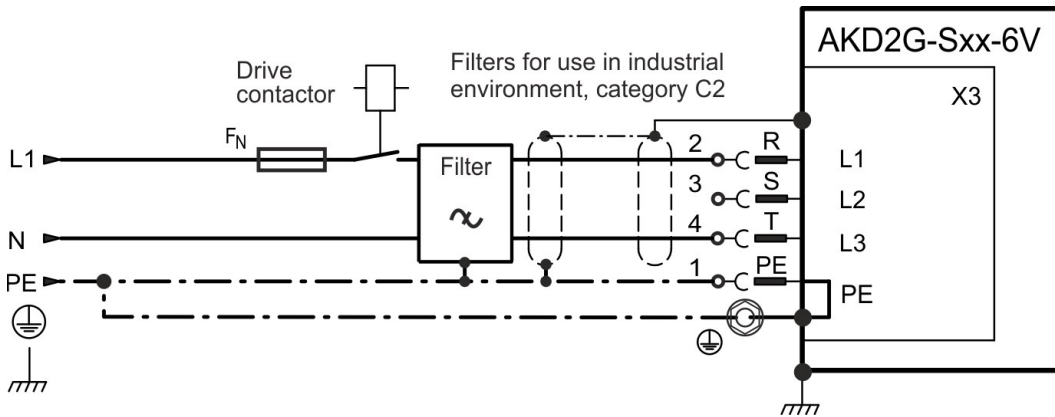

#### Two phases AC mains (AKD2G-Sxx-6V)

- Directly to two-phase supply network without neutral line.
- Activate single phase supply (VBUS.THREEPHASE = 0).
- Set VBUS.ACNOMINAL to desired nominal AC line voltage for lines other than nominal rated VAC.
- For complete information refer to WorkBench online help, AKD2G-S User Manual, section Power Setting.
- AC line filtering to be provided by the user. Use filter type FN2090, refer to the *Accessories Manual* for more information. Use shielded cable between filter and drive.

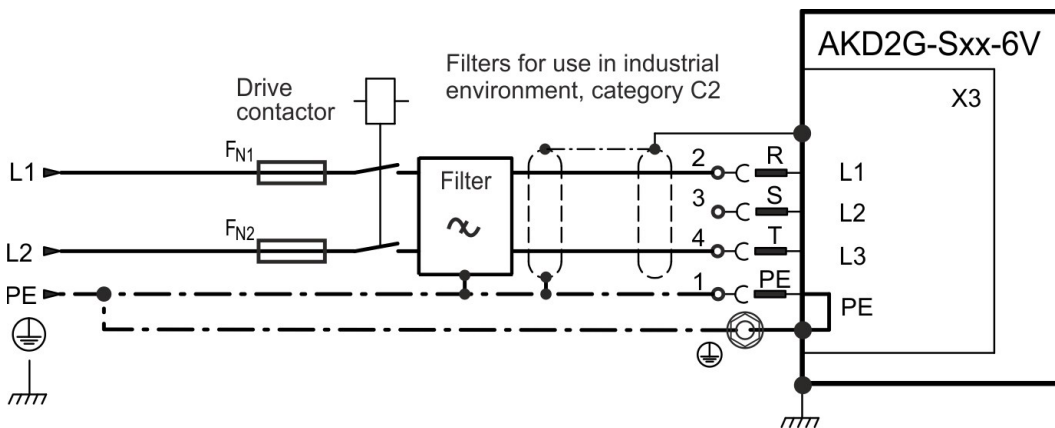

**Three phases AC mains (all AKD2G-Sxx-)**

- Directly to 3-phase supply network.
- Activate 3-phase supply (VBUS.THREEPHASE = 1).
- Set VBUS.ACNO MINAL to desired nominal AC line voltage for lines other than nominal rated VAC.
- For complete information refer to WorkBench online help, AKD2G-S User Manual, section Power Setting.
- AC line filtering to be provided by the user. Refer to the *Accessories Manual* for more filter description. Use shielded cable between filter and drive.
  - AKD2G-Sxx-6V:
    - Motor cable < 10 m: use filter FN 3288 in industrial environment, category C2.
    - Motor cable ≥ 10 m: use filter FN 3288 in industrial environment, category C3.
  - AKD2G-Sxx-7V up to 12 Amps:
    - Motor cable < 10 m: no filter, in industrial environment, category C3.
    - Motor cable < 10 m: use filter FN 3288 in industrial environment, category C2.
    - Motor cable ≥ 10 m: use filter FN 3288 in industrial environment, category C3.
  - AKD2G-Sxx-7V 24:
    - Motor cable < 10 m: no filter, in industrial environment, category C2.
    - Motor cable ≥ 10 m: no filter, in industrial environment, category C3.
    - Motor cable ≥ 10 m: use filter FN 3288 in industrial environment, category C2.

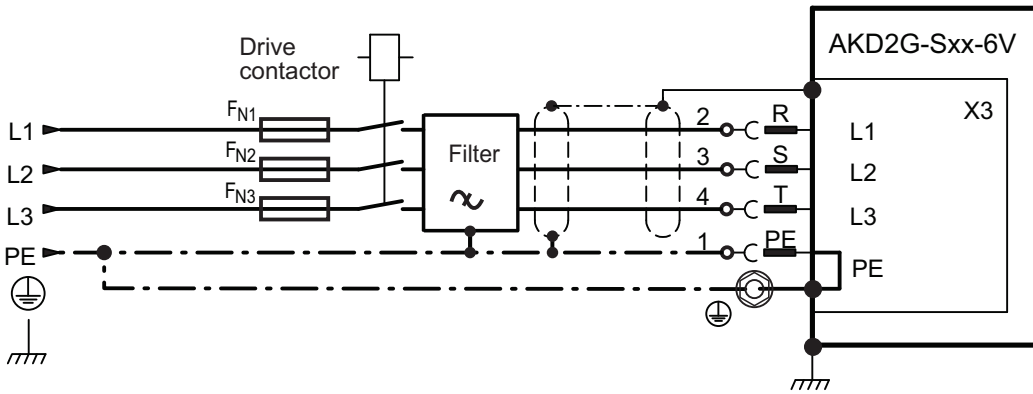

Motor Cable Length	EMI Category
< 10 m	C2
≥ 10 m	C3

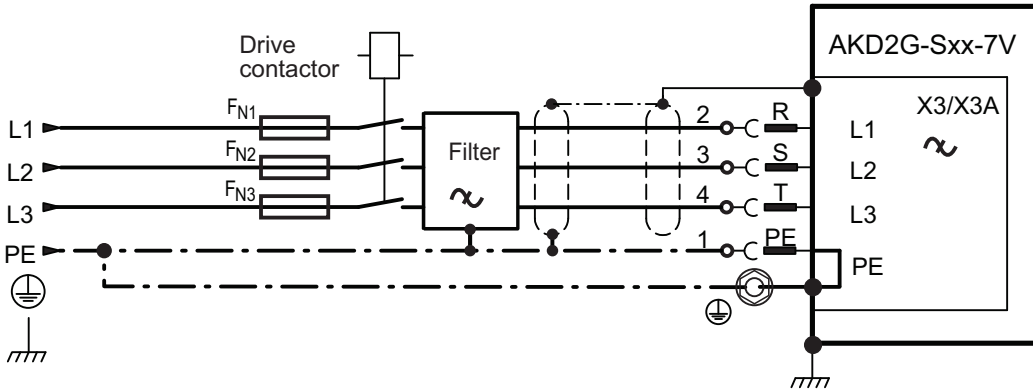

Motor Cable Length	EMI Category	
	AKD2G 3-12 A	AKD2G 24 A
< 10 m	C3	-
≥ 10 m	C2	C2

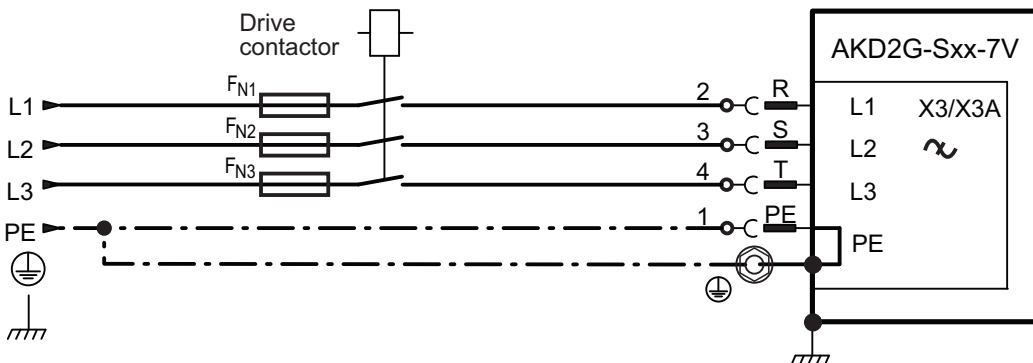

Motor Cable Length	EMI Category	
	AKD2G 3-12 A	AKD2G 24 A
< 10 m	C3	C2
≥ 10 m	-	C3



**DC supply (all AKD2G-Sxx-)**

- Activate DC supply (VBUS.DCOPERATION = 1) and set VBUS.DCNOMINAL.
- Any DC supply filtering for AKD2G-Sxx-6V to be provided by the user.

DC Supply to mains lines R/T (L1/L3)

DC power source is connected to the drive AC line inputs. This wiring provides soft start of the energy storage capacitors inside the drive and the AC rectifier diodes prevents motor regeneration energy from returning to the dc power source. That is, by powering the drive from the AC line input connections, the drive's energy absorption and energy dissipation mechanisms can work normally.

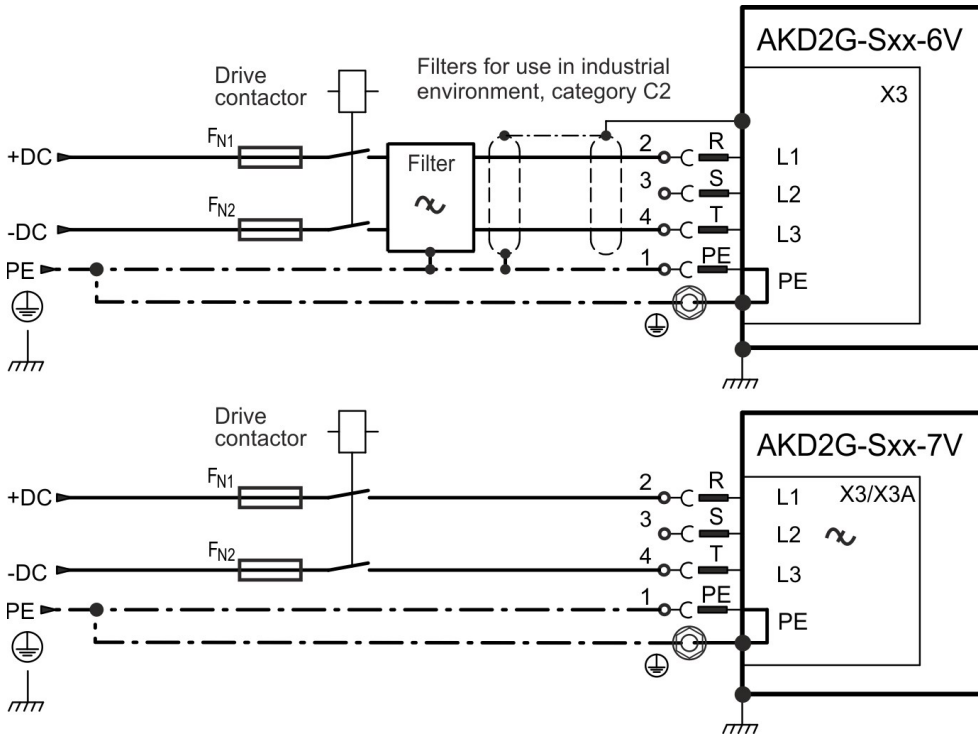

DC Supply to DC Bus lines X3/7-8

**NOTICE**

When wiring DC power supply to the drive DC Bus terminals X3/X3B pins 7 and 8, the user is responsible for current and power management using additional external devices. For more information refer to [KDN \(AKD2G Low Voltage DC Operation\)](#).

**User responsibility:**

- The power supply system design must ensure inrush current protection by limiting input current during power up.
- Provide a means to safely absorb energy from the motor when slowing down/regenerating. UL Rating for DC requires that DC is created from an AC source. Other forms of DC are not covered by the UL listing.
- DC supply polarity must be properly wired. Improper polarity of DC power will damage the drive and void warranty.

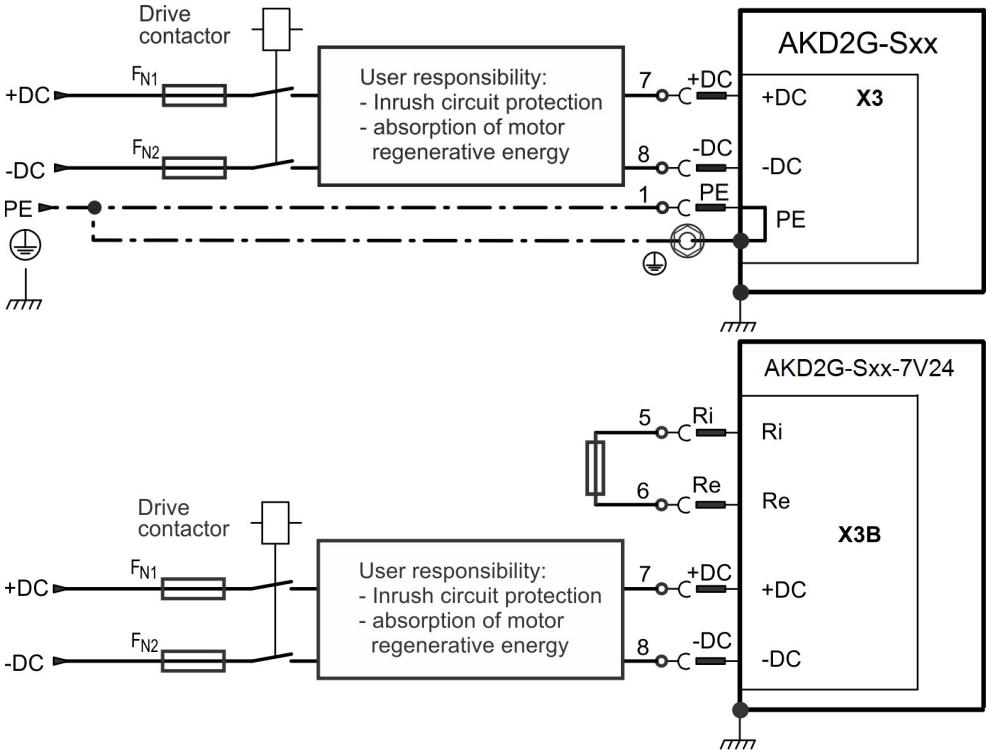

### 8.6.2.2 Fusing

Fuse types	Description
US fuses	<ul style="list-style-type: none"> <li>Class J, 600 VAC, 200 kA SCCR, time-delay</li> <li>must be UL and CSA listed</li> </ul> <p>Alternate fuses and breakers to Class J must have similar or better <math>I_p</math> and <math>I^2T</math> performance per UL 508A SB4.2 at max. 10 kA SCCR rating.</p>
EU fuses	<ul style="list-style-type: none"> <li>Types gS or gG, 400 V/500 V, time-delay</li> <li>max. 10 kA SCCR</li> </ul>
Semiconductor	<ul style="list-style-type: none"> <li>max. 65 kA SCCR</li> </ul>
Fuse holders	Use finger-safe fuse holders according to EN 60529 in combination with the standard fuse blocks.
Automatic circuit breakers	<ul style="list-style-type: none"> <li>max. 30 A</li> <li>max. 10 kA SCCR</li> </ul>
Group installation fusing	<ul style="list-style-type: none"> <li>max. 30 A</li> </ul>

#### AC supply, single drives, line fusing

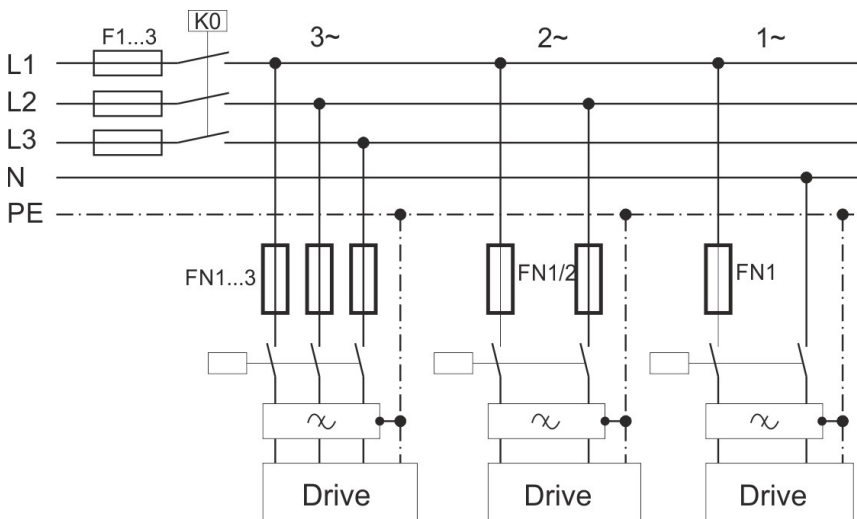

- F1, F2, F3: depends on sum of application's required input currents and cabinet requirements.
- Filters for special EMC requirements only (→ # 198).
- FN1, FN2, FN3 maximum rating: 30 A.
- FN1, FN2, FN3 recommended rating see table below:

Drive Model	FN1, FN2, FN3: Ampere rating	Example class J Eaton Bussmann	Example class J Mersen
AKD2G-Sxx-6V03S	10 A (Time-Delay)	LPJ10SP, DFJ10	AJT10, HSJ10
AKD2G-Sxx-6V06S AKD2G-Sxx-6V03D	10 A (Time-Delay)	LPJ10SP, DFJ10	AJT10, HSJ10
AKD2G-Sxx-6V12S AKD2G-Sxx-6V06D	15 A (Time-Delay)	LPJ15SP, DFJ15	AJT15, HSJ15
AKD2G-Sxx-7V03S	10 A (Time-Delay)	LPJ-10SP, DFJ-10	AJT10, HSJ10
AKD2G-Sxx-7V06S AKD2G-Sxx-7V03D	10 A (Time-Delay)	LPJ-10SP, DFJ-10	AJT10, HSJ10
AKD2G-Sxx-7V12S AKD2G-Sxx-7V06D	15 A (Time-Delay)	LPJ-15SP, DFJ-15	AJT15, HSJ15
AKD2G-Sxx-7V24S	25 A (Time-Delay)	LPJ-25SP, DFJ-25	AJT25, HSJ25
Drive Model	FN1, FN2, FN3: Ampere rating	Semi-conductor Eaton/Bussmann	Semi-conductor Mersen
AKD2G-Sxx-6V03S	10 A	FWP-10G14F	FR14GR69V10
AKD2G-Sxx-6V06S AKD2G-Sxx-6V03D	10 A	FWP-10G14F	FR14GR69V10
AKD2G-Sxx-6V12S AKD2G-Sxx-6V06D	15 A	FWP-16G14F	FR14GR69V16
AKD2G-Sxx-7V03S	10 A	FWP-10G14F	FR14GR69V10
AKD2G-Sxx-7V06S AKD2G-Sxx-7V03D	10 A	FWP-10G14F	FR14GR69V10
AKD2G-Sxx-7V12S AKD2G-Sxx-7V06D	15 A	FWP-16G14F	FR14GR69V16
AKD2G-Sxx-7V24S	32 A	FWP-32G14F	FR14GR69V32

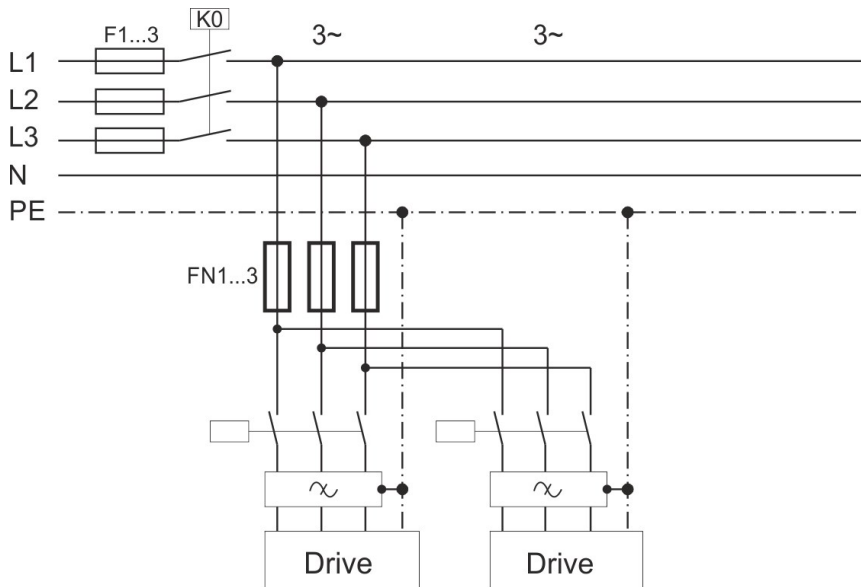
**AC supply, group of drives, line fusing**

- F1, F2, F3: depends on sum of application's required input currents and cabinet requirements.
- Filters for special EMC requirements only (→ # 198).
- FN1, FN2, FN3 maximum rating: fuse size for group installation is limited to 30 A max. and 32 A max. for Semiconductor fuses.
- FN1, FN2, FN3 rating should be  $1.25 * \text{sum current}$ .

Group sum current	FN1, FN2, FN3: Ampere rating	Eaton Bussmann	Mersen
6 A to 30 A	30 A (Time-Delay)	<b>Example class J</b> LPJ30SP, DFJ30	<b>Example class J</b> AJT30, HSJ30
	32 A	<b>Semiconductor</b> FWP-32G14F	<b>Semiconductor</b> FR14GR69V32

**AC supply, single drives, automatic circuit breakers**

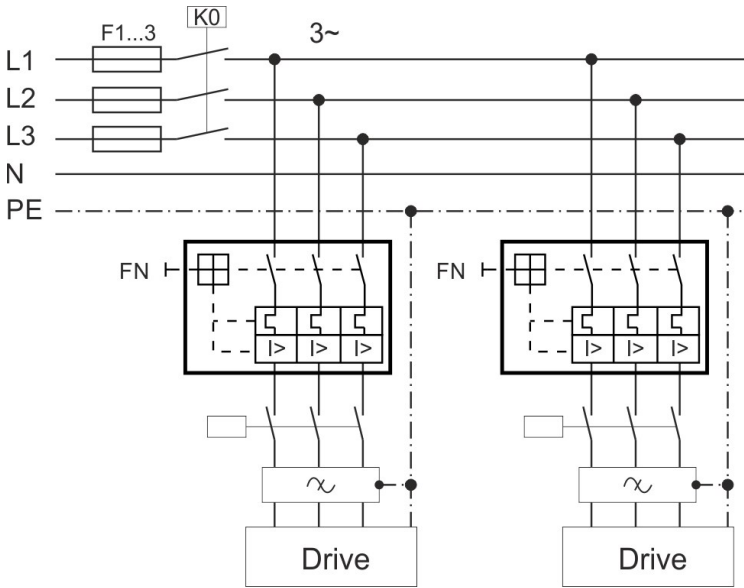

- F1, F2, F3: depends on the sum of application's required input currents and cabinet requirements.
- Filters for special EMC requirements only (→ # 198).
- FN maximum rating: 30 A
- FN recommended rating and regional approvals see table below:

Drive Model	Ampere rating	SCCR rating	Example ABB
AKD2G-Sxx-6V	15 A	10 kA	SU203M-K15
AKD2G-Sxx-7V	15 A	10 kA	SU203M-K15
AKD2G-Sxx-7V24x	30 A	10 kA	SU203M-K30

**AC supply, group of drives, automatic circuit breakers**

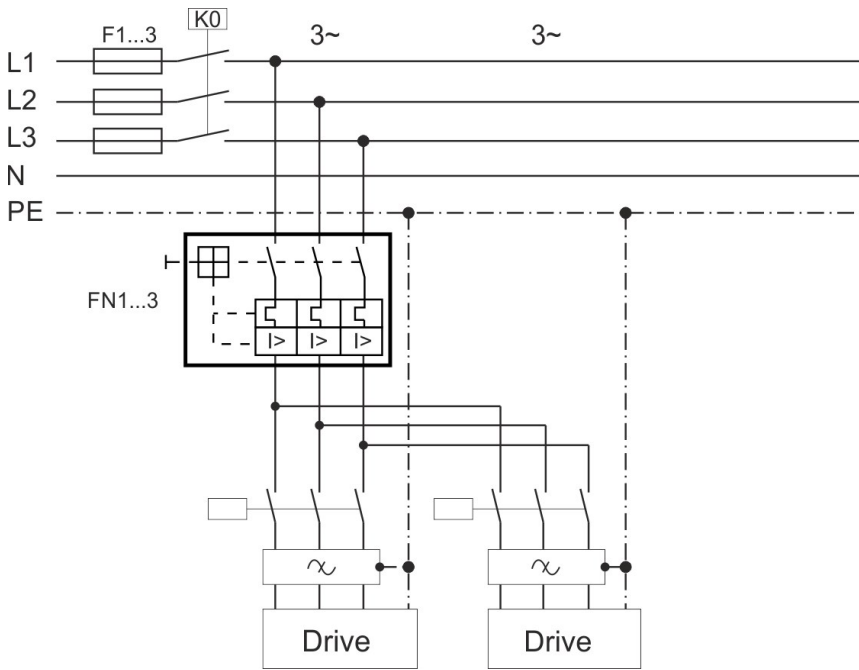

- F1, F2, F3: depends on sum of application's required input currents and cabinet requirements.
- Filters for special EMC requirements only (→ # 198).
- FN maximum rating: circuit breaker size for group installation is limited to 30 A max.
- FN rating should be  $1.25 \cdot \text{sum current}$ .
- FN recommended rating and regional approvals see table below:

Group sum current	Ampere rating	SCCR rating	Example UL ABB
<b>AKD2G-Sxx-6V</b>			
6 A to 9 A	15 A	10 kA	SU203M-K15
12 A to 15 A	20 A	10 kA	SU203M-K20
18 A to 24 A	30 A	10 kA	SU203M-K30
27 A to 36 A	30 A	10 kA	SU203M-K30
<b>AKD2G-Sxx-7V</b>			
6 A to 9 A	15 A	10 kA	SU203M-K15
12 A to 15 A	20 A	10 kA	SU203M-K20
18 A to 24 A	30 A	10 kA	SU203M-K30
27 A to 36 A	30 A	10 kA	SU203M-K30

**DC supply, single drives, line fusing**

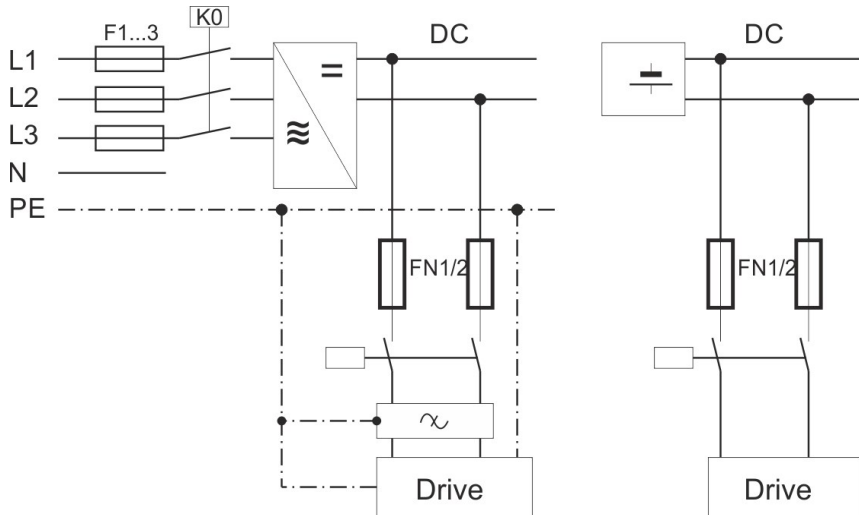

- F1, F2, F3: depends on sum of application's required input currents and cabinet requirements.
- Filters for special EMC requirements only (→ # 198).
- FN1, FN2 maximum rating 30 A
- FN1, FN2 recommended rating see table below:

Drive Model	Ampere rating	Example Eaton Bussmann	Example Mersen
AKD2G-Sxx-6V03S	10 A (Time-Delay)	DFJ-10	HP6M10
AKD2G-Sxx-6V06S AKD2G-Sxx-6V03D	15 A (Time-Delay)	DFJ-15	HP6M15
AKD2G-Sxx-6V12S AKD2G-Sxx-6V06D	15 A (Time-Delay)	DFJ-15	HP6M15
AKD2G-Sxx-7V03S	10 A (Time-Delay)	FWP-10B	HP10M10
AKD2G-Sxx-7V06S AKD2G-Sxx-7V03D	10 A (Time-Delay)	FWP-10B	HP10M10
AKD2G-Sxx-7V12S AKD2G-Sxx-7V06D	15 A (Time-Delay)	FWP-15B	HP10M15
AKD2G-Sxx-7V24S	25 A (Time-Delay)	FWP-25B	HP10M25



### 8.6.3 Auxiliary voltage power supply connector X10

The following diagram describes external 24 VDC power supply (PELV). The required supply current rating depends on the use of motor brake (→ # 35) or (→ # 35).



- 2 pin, pitch 5.08 mm
- T-type mating connector data (→ # 54)
- Undervoltage fault limit 19 V
- Overvoltage fault limit 30 V

Pin	Signal	Description
1	+ 24 V	+24 VDC supply voltage, PELV
2	GND	Ground for 24 VDC supply voltage, PELV

For control supply current requirement specifications see section (→ # 39).

#### 8.6.3.1 Fusing

Use 24 VDC supply manufacturer's recommendation for fusing.

#### 8.6.3.2 Wiring example 24 VDC supply

Maximum current for one string of daisy-chained X10T connectors is 20 A. The sum of the control currents of the connected drives should not exceed 20 A. With the data given in the table above, you can connect for example: 6 single axis drives, or 4 dual axis drives, or 3 single + 2 dual axis drives.

Wiring example with three phase power supply unit:

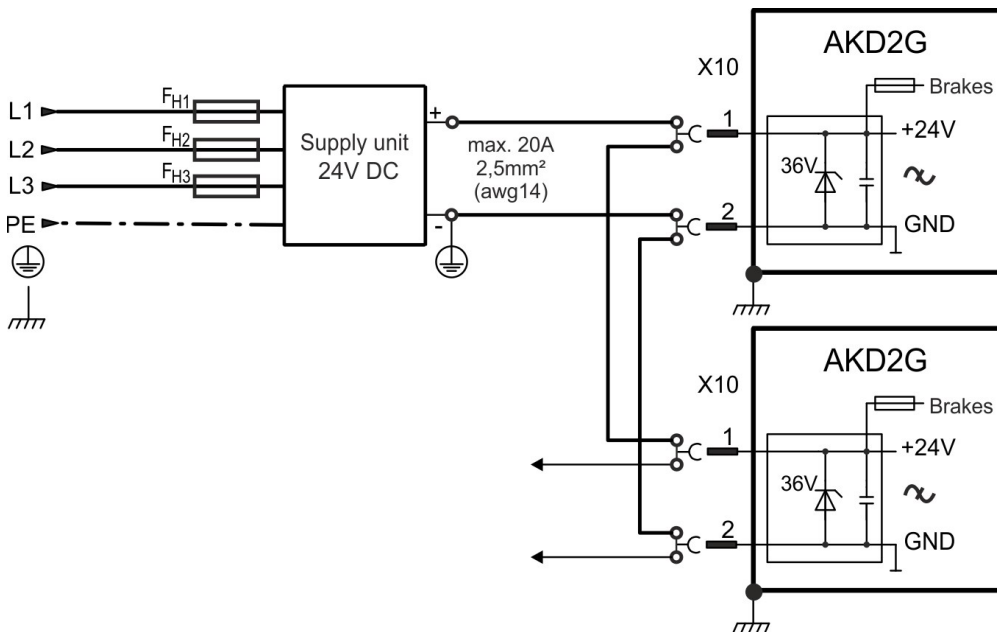

## 8.7 DC Bus link connector X3/X3B

The DC bus link can be connected in parallel so that the power returned from slowing down motors is divided between all the drives that are connected to the same DC bus link circuit. Every drive must have its own power connection to mains voltage sharing the same branch, over current protection devices, even if the DC bus link is used. Drives working generatively very often should be placed beside drives, which need energy. That reduces current flow on longer distances.

**NOTE**

The sum of the application currents in the connected in parallel DC bus wires must not exceed 48 A. Wiring: Use 6 mm<sup>2</sup> unshielded single cores with a max. length of 200 mm; use 6 mm<sup>2</sup> shielded cables for longer lengths. In this case no fuse for line protection is required.

**NOTICE**

The drives can be destroyed if DC bus link voltages are different. Only drives with mains supply that share the same AC branch, over current protection devices (identical mains supply voltage) may have the DC bus links interconnected.

Interconnection of DC bus links works best in systems powered by 3-phase AC or DC power. Consult Kollmorgen for DC bus linking with single phase AC power input.

- 8/4 pin, pitch 7.62/10.16 mm
- Optional T version (not available for 7V24 drives)
- Mating connector data (→ # 54)

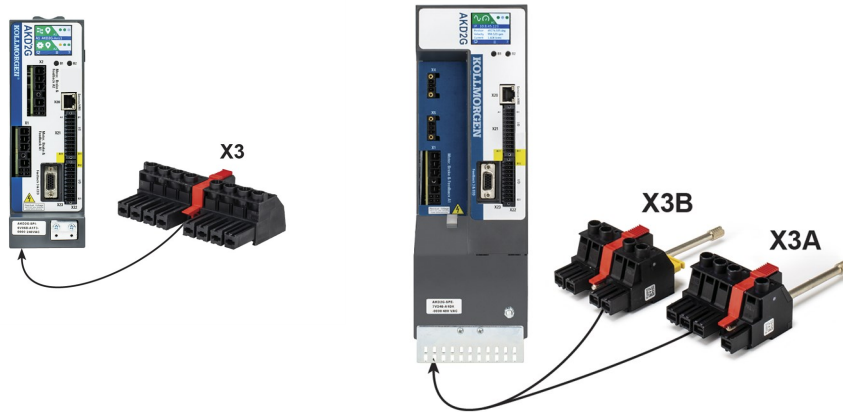

Pin	Label	Signal	Description
7	+DC	+DC	DC Bus link positive
8	-DC	-DC	DC Bus link negative

### 8.7.1 Fusing

External regen fusing FB1/FB2 (→ # 95). DC bus link fusing depends on topology (see (→ # 93)).

Wiring topology	Ampere rating@240V	Ampere rating@480V	Example Eaton:	Example Mersen:
<b>AKD2G-Sxx-6V</b>				
Group: Fgroup	max. 30 A	na	DFJ-30	HP6M30
Busbar: Fbus	max. 15 A	na	DFJ-15	HP6M15
<b>AKD2G-Sxx-7V</b>				
Group: Fgroup	max. 30 A		FWP-30B	HP10M30
Busbar: Fbus	max. 15 A		FWP-15B	HP10M15

### 8.7.2 Wiring example with T connectors

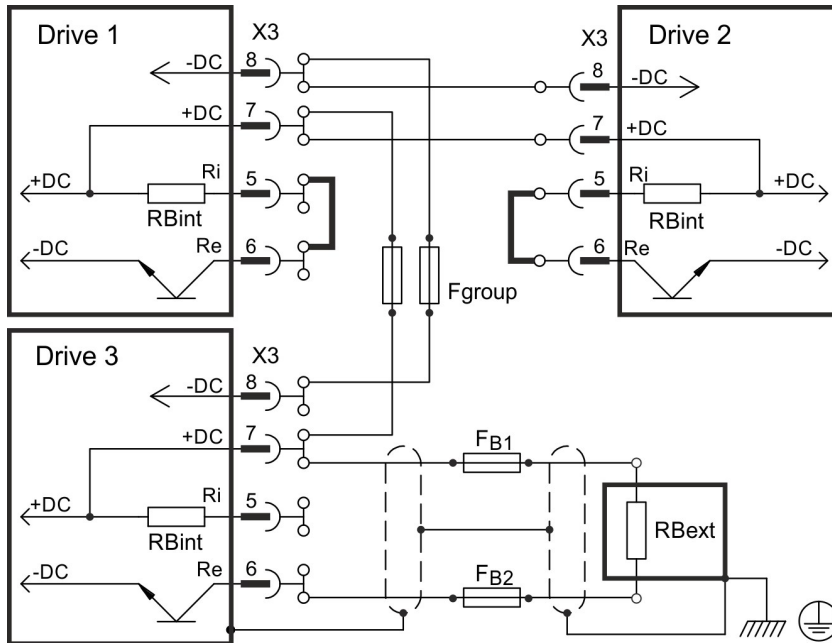

**Note:** T connectors are not available for 7V24 drives.

Without DC Bus fuses, other devices can become damaged or destroyed if, for example, a device fails due to an internal short circuit. If multiple drives are connected in parallel, then it is usual to insert DC Bus fuses (Fgroup) between groups of drives (with a group consisting of two or three devices, depending on the current) in order to limit any possible resulting damage. Fgroup fuses cannot avoid damage by current peaks completely.

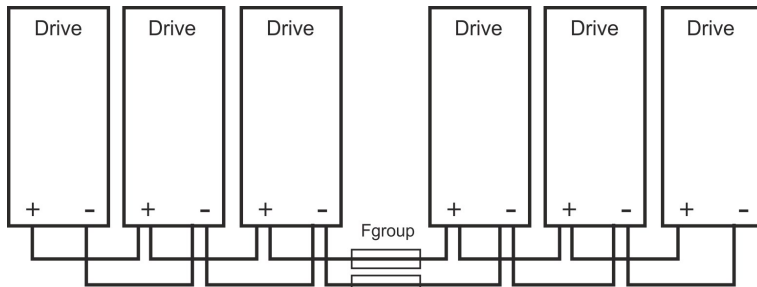

### 8.7.3 Wiring example with busbar

If a device fails in this system due to a short-circuit, only its fuses (Fbus) are tripped and the rest of the network continues uninterrupted. The solid busbars can conduct significantly larger currents than T connectors, because the compensating current does not flow through the connector as above.

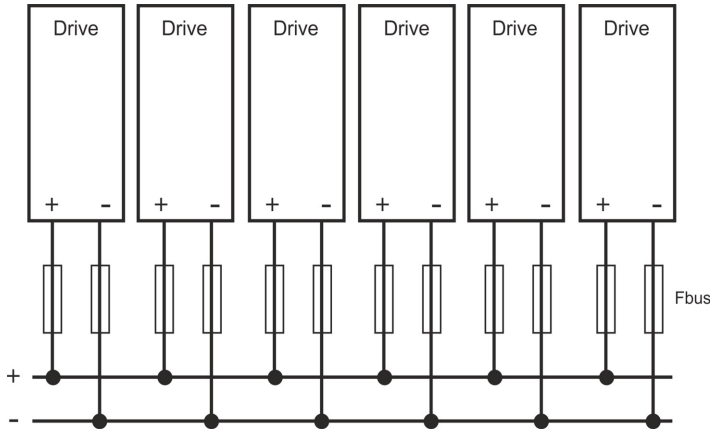

## 8.8 Regen resistor connector X3/X3B

For technical data on the regenerative brake circuit (→ # 40).

**NOTE**

Fusing (such as fusible cut-outs or power switches) to be provided by the user.

- 8/4 pin, pitch 7.62/10.16 mm
- Optional T version (not available on 7V24S model)
- Mating connector data (→ # 54).
- X3/5 to X3/6 must be shorted to use the built in regen resistor. Remove the jumper to connect an external regen resistor.
- X3B/5 to X3B/6 must be shorted for internal regen (7V24). Remove the jumper for external regen.
- Refer to the WorkBench online help for parameter setting (REGEN.EXT, REGEN.REXT, REGEN.WATTEXT)

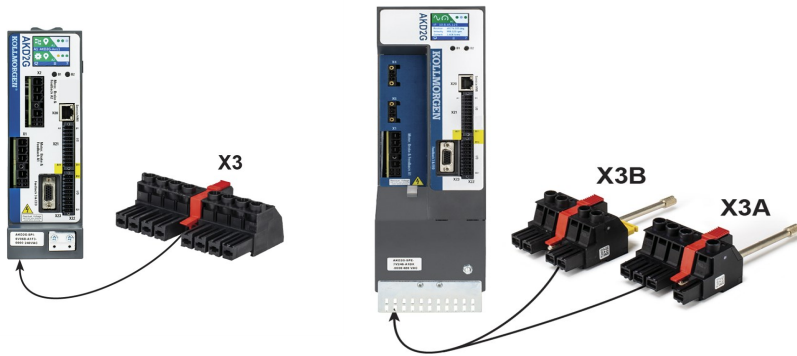

Pin	Label	Signal	Description
5	Ri	RBint	internal Regen resistor
6	Re	-RB	external Regen resistor -
7	+DC	+RBext	external Regen resistor +

### 8.8.1 Fusing and Wiring

#### FB1 / FB2 fusing

Drive Model	Ampere rating@240V	Ampere rating@480V	Example: Eaton	Example: Siba
all AKD2G-Sxx	10A	40A	FWP-xxA14F	110V to 400V: gRL(gS) 400V to 480V: aR

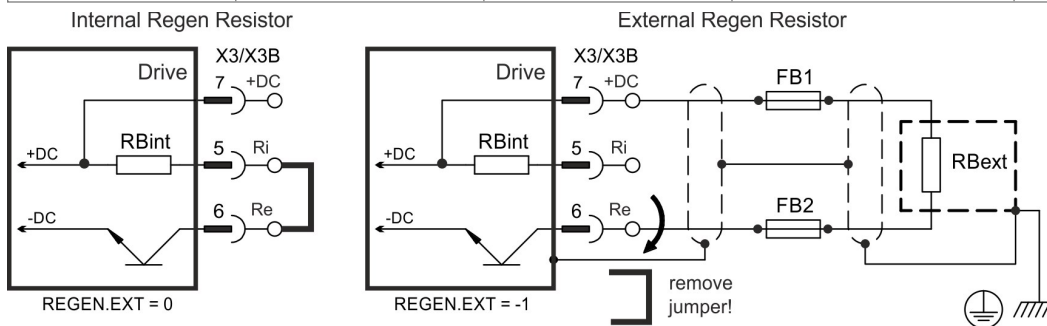

## 8.9 Motor Power, Brake and Feedback connection

The AKD2G drive is able to protect the connected motor from overloading, if the parameters are set correctly and the thermal protection sensor is connected and supervised. With Kollmorgen motors the valid data are automatically set by the WorkBench motor database. Refer to parameter AXIS#.MOTOR.RTYPE for supported thermal sensors.

### NOTICE

The dynamic voltage rise can lead to a reduction in the motor operating life and, on unsuitable motors, to flashovers in the motor winding.

- Only install motors with insulation class F (acc. to IEC60085) or above.
- Only install cables that meet the requirements (→ # 55).

### 8.9.1 Motor connectivity, some examples

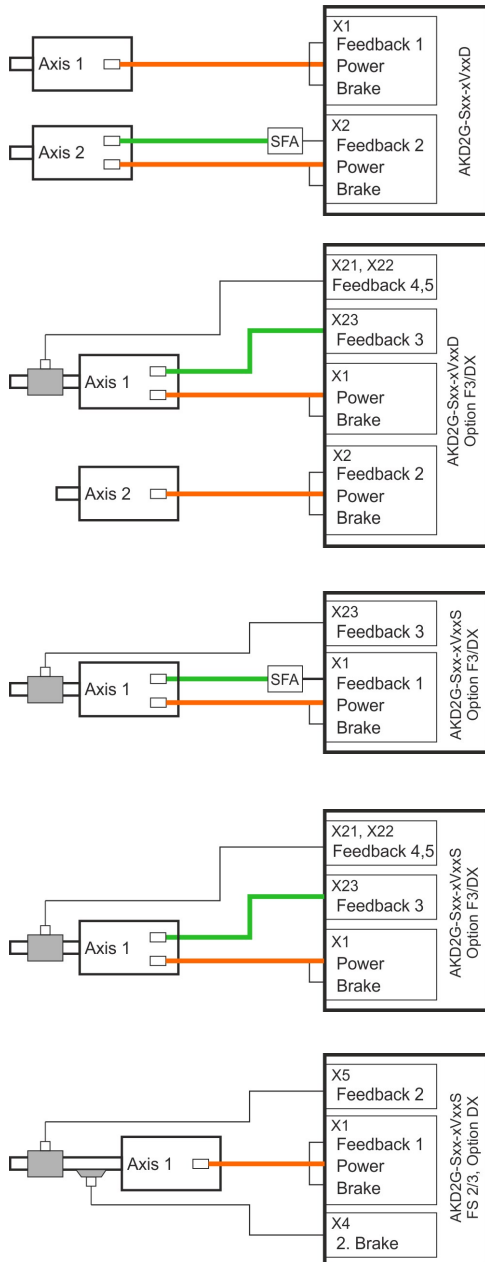

- Axis 1: single cable connection (→ # 97)
  - commutation feedback: SFD3 or DSL
- Axis 2: dual cable connection (→ # 97)
  - commutation feedback: EnDAT, HIPERFACE, Resolver etc. by using SFA
- Axis 1: dual cable connection (→ # 99)
  - commutation feedback: Resolver, SFD, EnDAT, HIPERFACE, BiSS, SinCos, ComCoder, Hall, SmartAbs etc. by using X23
  - position feedback:
    - X21: Step/Direction
    - X22: Step/Direction or incremental encoder
- Axis 2: single cable connection (→ # 97)
  - commutation feedback: SFD3 or DSL
- Axis 1: dual cable connection (→ # 99)
  - commutation feedback: EnDAT, HIPERFACE, Resolver etc. by using SFA
  - position feedback: Resolver, SFD, EnDAT, HIPERFACE, BiSS, SinCos, ComCoder, Hall, SmartAbs etc. by using X23
- Axis 1: dual cable connection (→ # 99)
  - commutation feedback: Resolver, SFD, EnDAT, HIPERFACE, BiSS, SinCos, ComCoder, Hall, SmartAbs etc. by using X23
  - position feedback:
    - X21: Step/Direction
    - X22: Step/Direction or incremental encoder
- Axis 1 (7V24S model only): single cable connection (→ # 97)
  - commutation feedback: SFD3 or DSL
  - position feedback: SFD3 or DSL or SFA at X5
  - secondary brake by using X4

## 8.9.2 Single motor cable connection

Motors with two wire feedback systems like SFD3 or Hiperface DSL can be connected to AKD2G by using a single Kollmorgen hybrid cable. Depending on the AKD2G version (single or dual axis), one or two single cable motor connections are possible.

Drive type	Commutation Axis 1	Commutation Axis 2	Velocity/Position loop closure			
Single axis standard	X1	-	-	X21	-	-
Single axis with Option I/O	X1	-	-	X21	X22	-
Single axis with Option F3	X1	-	-	X21	-	X23
Single axis with Option DX	X1	-	-	X21	X22	X23
Dual axis standard	X1	X2	-	X21	X22	-
Dual axis with Option DX	X1	X2	-	X21	X22	X23

### 8.9.2.1 Motor Power, Brake and Feedback connectors X1, X2

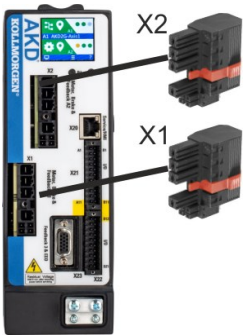

- X1 (Feedback 1) / X2 (Feedback 2)
- Motor Power: 4 pin, pitch 7.62 mm
- Motor Brake: 2 pin, pitch 3.81 mm
- Motor Feedback: 2 pin, pitch 3.81 mm
- Cable length: (→ # 55)
- Use Kollmorgen cables
- Mating connector data (→ # 54).
- Feedback types: SFD3, HIPERFACE DSL
  - Rated voltage 11 V.
  - Rated current is 350 mA simultaneously for X1 and X2.

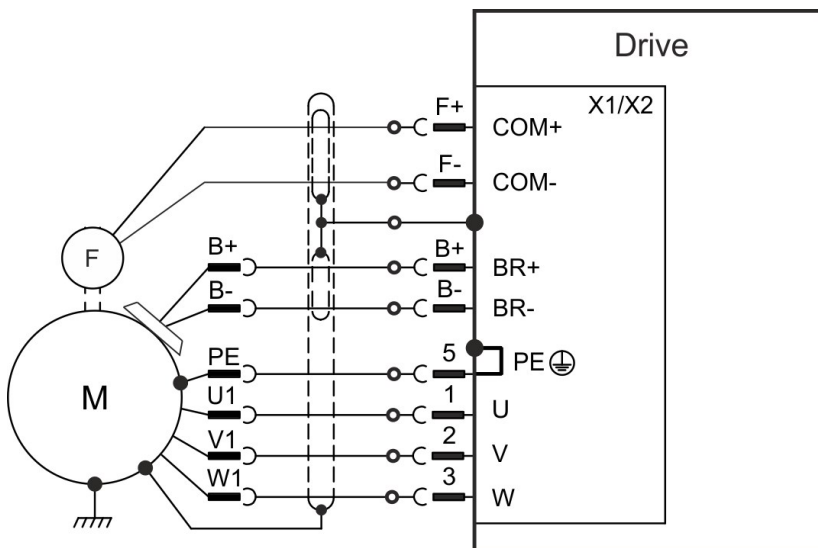

Pinout is identical for connectors X1 and X2.

Pin	Signal	Description
1	U	Motor phase U
2	V	Motor phase V
3	W	Motor phase W
5	PE	Protective earth
B+	BR+	Brake positive line (safety notes and details (→ # 101))
B-	BR-	Brake negative line (safety notes and details (→ # 101))
F+	COM+	SFD3, HIPERFACE DSL
F-	COM-	

### 8.9.2.2 Feedback connectors X21, X22, X23

- Velocity/Position loop closing
- Use Kollmorgen cables
- Mating connector data (→ # 54).
- Cable length: (→ # 55)

Connector	Functionality	Pinout, Wiring
X5	For single axis AKD2G-7V24S drives only. SFD3, DSL, SFA	(→ # 107)
X21	Step/Direction, CW/CCW	(→ # 108)
X22	Step/Direction, CW/CCW, Incr.Encoder, EnDAT, BiSS	(→ # 109)
X23	Several conventional feedback types	(→ # 110)

### 8.9.2.3 Secondary Brake connector X4

Connector X4 is standard on AKD2G-7V24S drives and is used for applications that require a secondary brake.

- Mating connector data (→ # 54).
- Cable length: (→ # 55)

Connector	Functionality	Pinout, Wiring
X4	For single axis drives only	(→ # 103)



### 8.9.3 Dual motor cable connection

Motors with conventional commutation feedback systems like resolver or sine encoder can be connected to AKD2G with separated power/brake and feedback cables. Feedback functions are assigned with parameters in WorkBench. Scaling and other settings are performed in WorkBench, too. Velocity / Position loop closing and electronic gearing / master-slave connection are possible by using X21, X22, X23 depending on the drive version and physical restrictions.



- X1 (Feedback 1) / X2 (Feedback 2)
  - Motor Power: 4 pin, pitch 7.62 mm
  - Motor Brake: 2 pin, pitch 3.81 mm
  - SFA connection: 2 pin, pitch 3.81 mm
  - Feedback types: see SFA connectivity (→ # 125)
- X23 (Feedback 3)
  - SubD HD 15 poles
  - Feedback types: see X23 connectivity (→ # 110)
- X21 (Feedback 4)
  - 2 x 11 pins (left connector A, right connector B)
  - Feedback types: see X21 connectivity (→ # 108)
- X22 (Feedback 5)
  - 2 x 10 pins (left connector A, right connector B)
  - Feedback types: see X22 connectivity (→ # 109)
- Mating connector data (→ # 54).

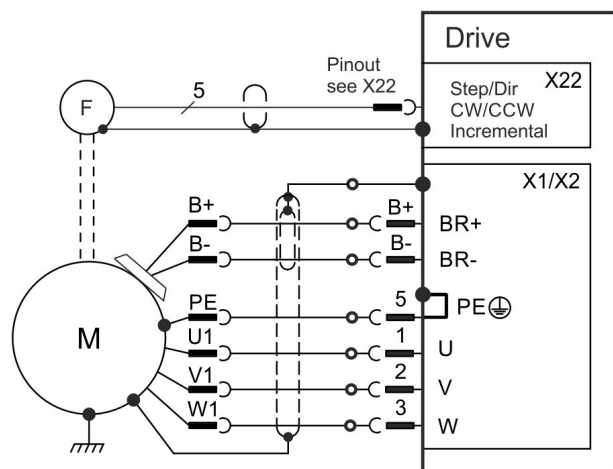
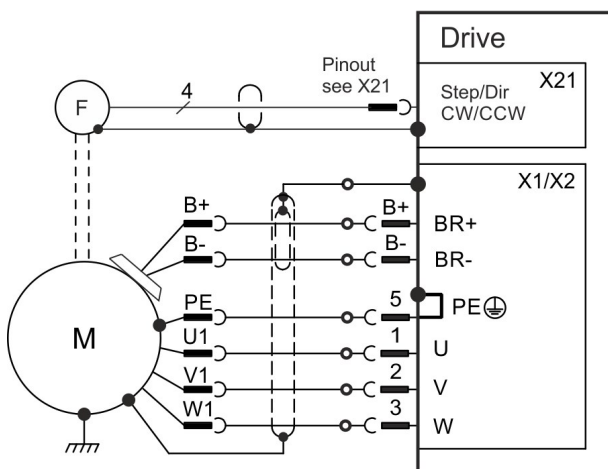
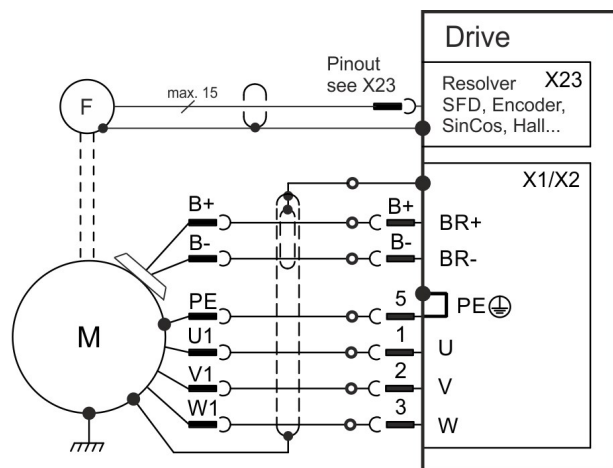
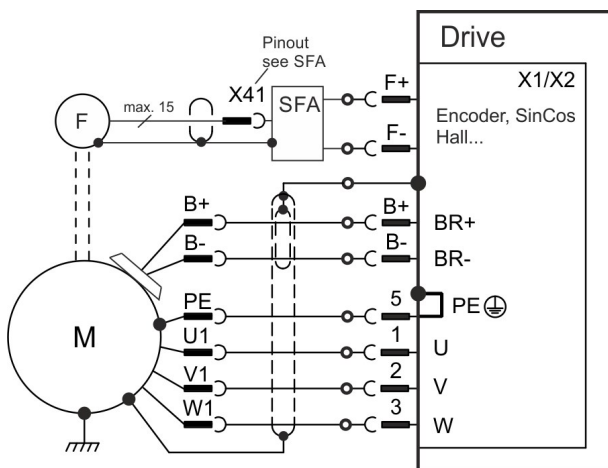

### 8.9.3.1 Motor power and motor brake connectors X1, X2

Usually these lines are part of the Kollmorgen motor cable connected to X1 or X2. For motor brake safety notes and functional details (→ # 101).

- Use Kollmorgen cables
- Mating connector data (→ # 54).
- Cable length: (→ # 55)

Pin	Signal	Description
1	U	Motor phase U
2	V	Motor phase V
3	W	Motor phase W
5	PE	Protective earth
B+	BR+	Brake positive, with Kollmorgen cables only
B-	BR-	Brake negative, with Kollmorgen cables only

### 8.9.3.2 Feedback connectors X1, X2, X5, X41, X21, X22, X23

- Use Kollmorgen cables
- Mating connector data (→ # 54).
- Cable length: (→ # 55)
- For feedback connection overview (→ # 104)

Connector	Functionality	Pinout, Wiring
X1/X2	SFD3, DSL, SFA	(→ # 106)
X5 (only on 24 A model)	For single axis drives only. SFD3, DSL, SFA	(→ # 107)
X41	SFA at X1 or X2 or X5, several conventional feedback types	(→ # 125)
X21	Step/Direction, CW/CCW	(→ # 108)
X22	Step/Direction, CW/CCW, Incr. Encoder, EnDAT, BiSS	(→ # 109)
X23	Several conventional feedback types	(→ # 110)

#### Feedback connector X1, X2, X5, X41

Conventional feedback systems can be connected to X1 or X2 or X5 by using the optional feedback adapter SFA. SFA offers the additional connector X41.

- Connector X1 is a standard connector. Input for SFD3, DSL, or SFA.
- Connector X2 is standard for dual-axis drives. Input for SFD3, DSL, or SFA.
- Connector X5 is optional for single axes drives. Input for SFD3, DSL, or SFA.
- SFA: adapter for several conventional feedback types

#### Feedback connector X21

- Connector X21 is a standard connector.
- Input for Step/Direction and CW/CCW.

#### Feedback connector X22

- Connector X22 is standard connector for dual-axis drives.
- Connector X22 is part of option DX or IO for single axis drives.
- Input for Step/Direction, CW/CCW, Incremental encoder

#### Feedback connector X23

- Connector X23 is part of option DX or F3.
- Input for several conventional feedback types.

### 8.9.3.3 7V24S Model Secondary Brake connector X4

Connector X4 is part of the 7V24S model single axis drive. Use for applications, which require a second brake.

- Mating connector data: (→ # 54).
- Cable length: (→ # 56)

Connector	Functionality	Pinout, Wiring
X4	For single axis drives only	(→ # 103)

### 8.9.4 Motor Holding Brake Connection

A 24 V holding brake in the motor can be controlled directly by the drive. For proper function, check voltage drop, measure voltage at brake input and check brake function (on and off).

Brake voltage supply by using 24 V  $\pm 10\%$  auxiliary voltage supply of the drive on X10. Minimum and maximum brake current see Electrical Data (→ # 36) respectively (→ # 38).

AKD2G offers motor brake outputs on connectors X1 and X2. The outputs can be mapped to the required axis with WorkBench.

Connector	Usable for
X1	Primary motor brake axis 1 or secondary brake for axis 2
X2	Primary motor brake axis 2 or secondary brake for axis 1



#### **⚠ WARNING** No functional safety!

Serious injury could result when the load is not properly blocked. The internal brake function does not ensure functional safety.

- Functional safety, e.g. with hanging load (vertical axes), requires an additional brake, controlled e.g. from the other axis or externally from a safety controller. The brakes can be mapped to an axis with WorkBench.
- The Hardware Enable does not initiate a controlled stop but switches off the power stage immediately.
- Set parameter `AXIS#.MOTOR.BRAKEIMM` to 1 with vertical axes, to apply the brake immediately after faults or Hardware Disable.

### Pinout X1 / X2

Pin	Signal	Description
B+	BR+	Brake positive line
B-	BR-	Brake negative line

### Wiring

Usually the brake lines are part of Kollmorgen cable connections to X1 and X2 (→ # 97).

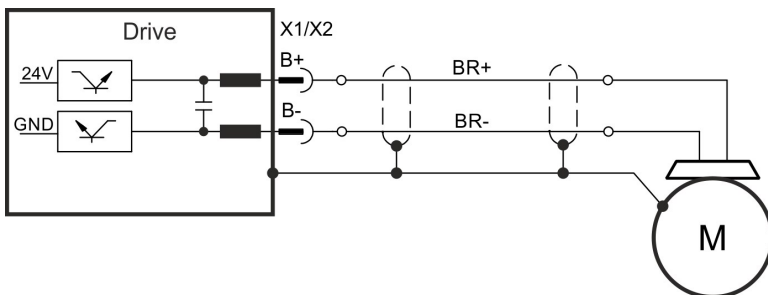

**Functionality**

The brake function must be enabled through a parameter. The diagram below shows the timing and functional relationships between the controlled stop signal, speed, and braking force. All values can be adjusted with parameters; values in the diagram are default values.

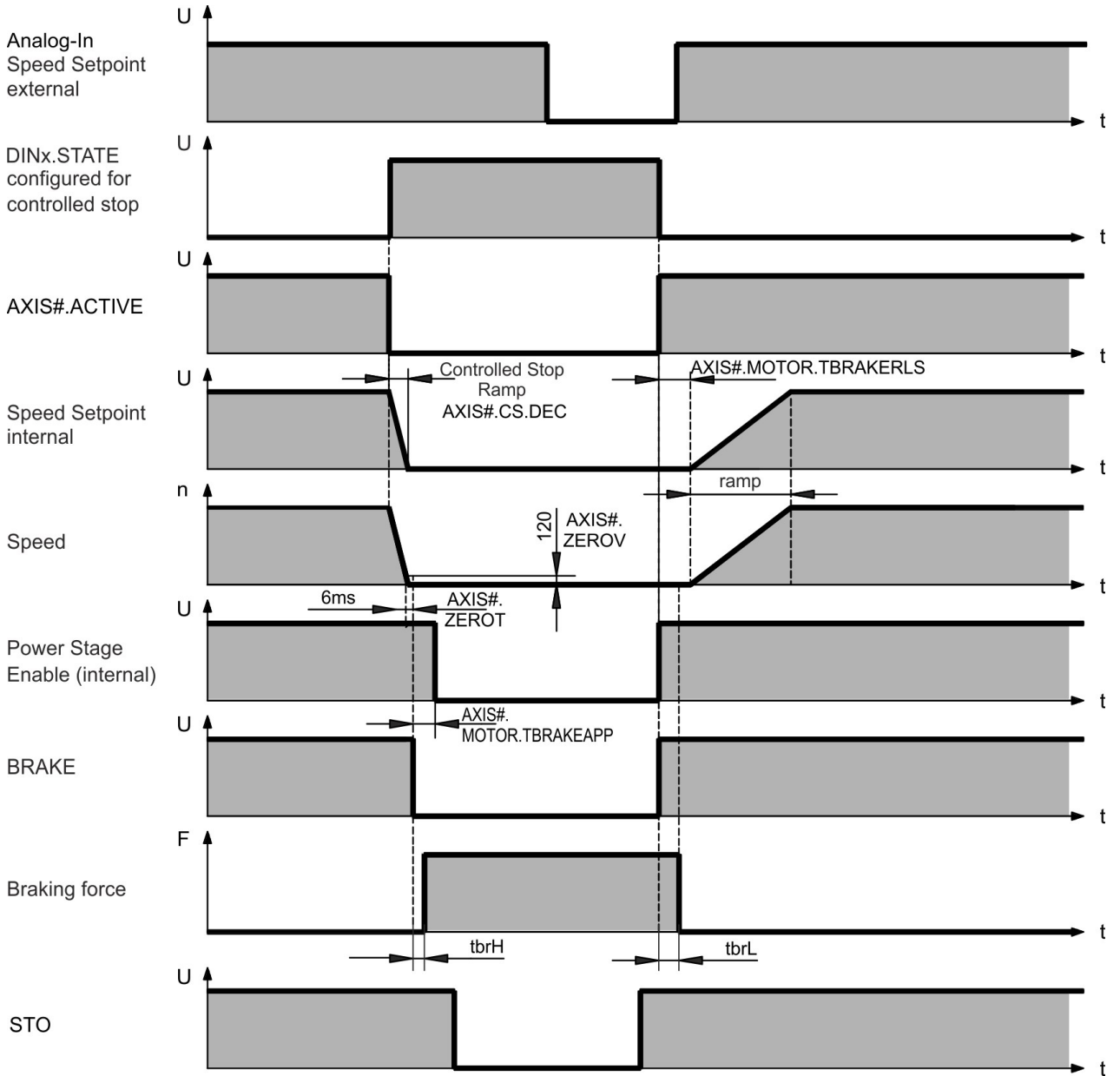

The drive speed setpoint is internally driven down an adjustable ramp (AXIS#.CS.DEC) to 0 V.

With default values the output for the brake is switched on when the speed has reached 5 rpm (AXIS#.ZEROV) for at least 6 ms (AXIS#.ZEROT). The rise ( $t_{brH}$ ) and fall ( $t_{brL}$ ) times of the holding brake that is built into the motor are different for the various types of motor.

### 8.9.4.1 Secondary Brake connector X4

Connector X4 is standard on AKD2G-7V24S drives and is used for applications that require a secondary brake.



- 3 pin, pitch 3.81 mm
- Second motor brake
- Mating connector data (→ # 54).

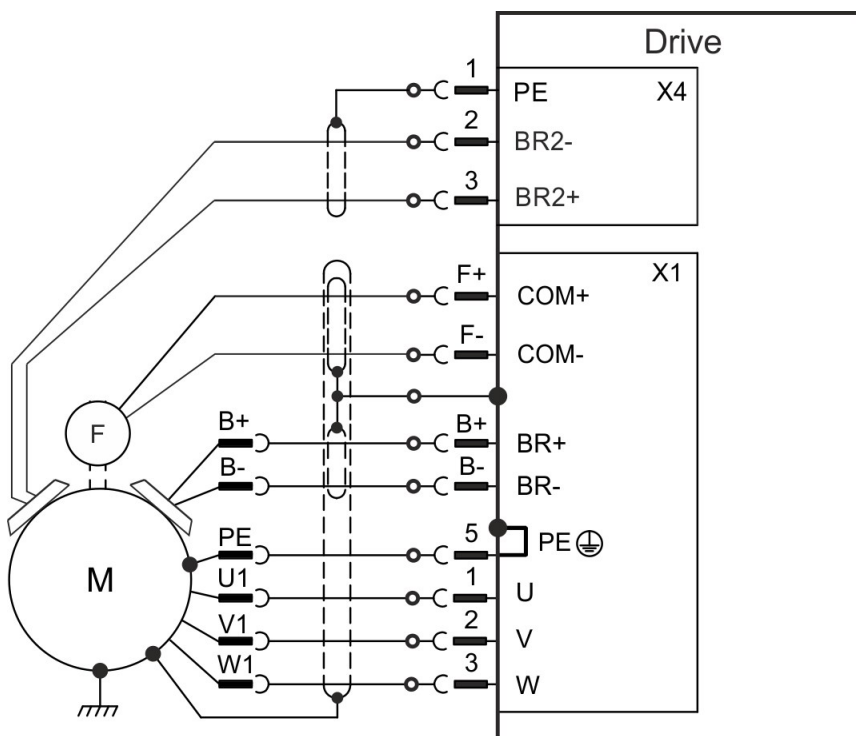

X4 Pin	Signal	Description
1	PE	Protective earth
2	BR2-	Second (external) brake -
3	BR2+	Second (external) brake +

## 8.10 Feedback Connection

### 8.10.1 Overview

AKD2G offers up to five feedback channels which can serve

- to commutate the motor (single cable (→ # 97) or dual cable (→ # 101)),
- to close the velocity and/or position loops,
- to act as a command source (electronic gearing, flying sheer, master-slave (→ # 139)),

The usage of the five channels may be freely configured in software, subject only to a few restrictions that are not physically sensible.

- Exactly one feedback channel per axis can commutate the motor.
- At most one feedback channel per axis can serve as the command source and the same feedback channel cannot also commutate the motor.
- A feedback channel can serve as the command source for more than one axis.
- FB1 cannot commutate axis 2. FB2 cannot commutate axis 1.

### 8.10.2 Feedback to Connector

Feedback channel	Connector	Usable for	Pinout
Feedback 1	X1	Axis 1: commutation feedback	(→ # 106)
	X41	Axis 1 by using SFA on X1: commutation feedback	(→ # 125)
Feedback 2	X2	Axis 2: commutation feedback	(→ # 106)
Feedback 2	X41	Axis 2 by using SFA on X2: commutation feedback	(→ # 125)
Feedback 2	X5	Single axis drive: velocity/position, command, safety	(→ # 107)
Feedback 2	X41	Single axis drive using SFA on X5: velocity/position, command, safety	(→ # 125)
Feedback 3	X23	commutation feedback, velocity/position, command	(→ # 110)
Feedback 4	X21	commutation feedback, velocity/position, command	(→ # 108)
Feedback 5	X22	commutation feedback, velocity/position, command	(→ # 109)

### 8.10.3 Feedback Type to Connector

Feedback Types	Connectors
SFD3	X1, X2, X5
Encoder HIPERFACE DSL	X1, X2, X5
Resolver	X23, X41
SFD	X23, X41
SinCos Encoder BiSS B (analog)	X23, X41
Encoder BiSS C (digital)	X22, X23, X41
SinCos Encoder EnDat 2.1	X23, X41
Encoder EnDat Digital 2.2	X22, X23, X41
Encoder HIPERFACE	X23, X41
Sine Encoder	X23, X41
Sine Encoder + Hall	X23, X41
Incremental Encoder	X21, X22, X23, X41
Incremental Encoder + Hall (Comcoder)	X23, X41
Hall Sensors	X23, X41
SSI	X22, X23, X41
SinCos Encoder + SSI	X23, X41
Step/Direction	X21, X22, X23
CW/CCW	X21, X22, X23

### 8.10.4 Maximum Cable Lengths by Feedback Type

Feedback Type	Single motor cable?	Up to 265 VAC / 375 VDC	Up to 528 VAC / 750 VDC
Resolver	No	100	100
SFD Gen 2 (4 wire)	No	50	50
SFD Gen 2 (4 wire)	Yes	50	35
SFD Gen 3 (2 wire)	Yes	50	25
Hiperface DSL	Yes	25	25
BiSS (B) Analog	No	50	50
BiSS (C) Digital	No	35	25
EnDat (2.1) Analog	No	50	50
EnDat (2.2) Digital	No	50	50
Hiperface Analog	No	50	50
1 Vpp with/without Hall	No	35	25
Inc Dig with/without Hall	No	35	25
Hall Only	No	35	25
SSI	No	35	25

Max. cable lengths in m.

### 8.10.5 Feedback Connectors X1, X2

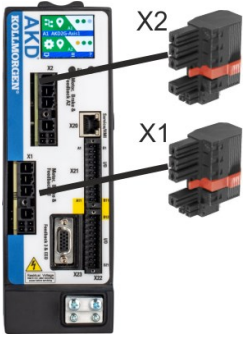

- 4 pin, pitch 7.62 mm plus 2x2 pin pitch 3.81 mm
- Input for commutation feedback: SFD3, DSL, SFA

#### Wiring example SFD3 or HIPERFACE DSL

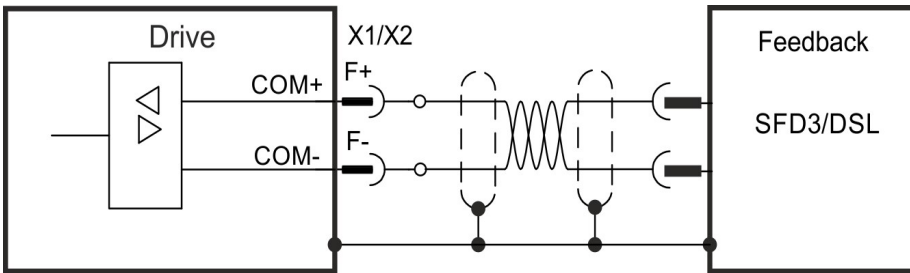

#### Wiring example conventional Feedback types with SFA

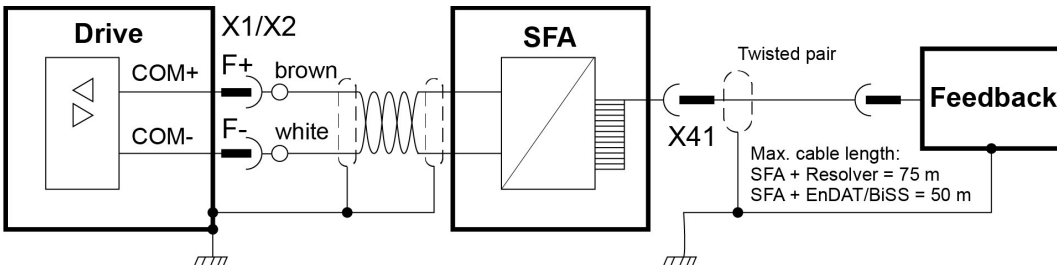

#### Electrical data

- Rated voltage 11 V.
- Rated current is 350 mA simultaneously for X1 and X2.

Pin	Signal	Description
F+	COM+	SFD3 +, HIPERFACE DSL +, SFA +
F-	COM-	SFD3 -, HIPERFACE DSL -, SFA -



### 8.10.6 Feedback Connector X5

Connector X5 is part of the single axis drives. Use this input for applications which require a safe feedback.



- 3 pin, pitch 3.81 mm
- Second 2 wire feedback, SFA
- Input for safe feedback.
- Feedback types: SFD3, HIPERFACE DSL
- Mating connector data (→ # 54).

#### Wiring example SFD3 or HIPERFACE DSL

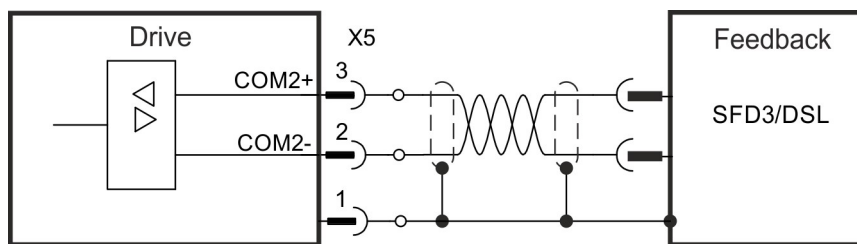

#### Wiring example conventional Feedback types with SFA

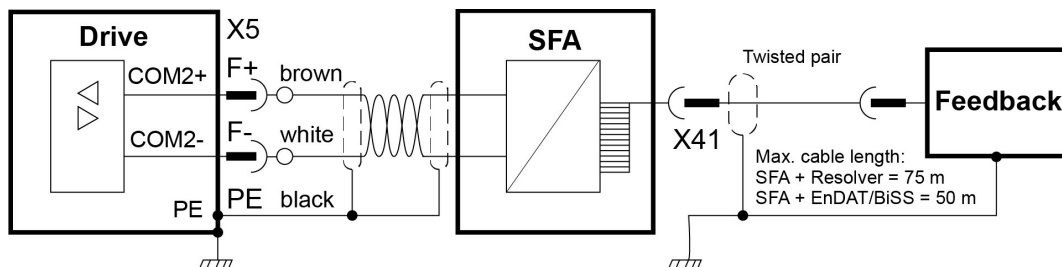

See the SFA X41 connector pinout summary and available feedback pinouts starting on (→ # 125).

X5 Pin	Signal	Description
1	PE	Cable shield (PE)
2	COM2-	Safe HIPERFACE DSL - or SFD3 - or SFA-
3	COM2+	Safe HIPERFACE DSL + or SFD3 + or SFA+

### 8.10.7 Feedback Connector X21



- 2 x 11 pins (left connector A, right connector B), pitch 3.5mm
- Fast input, isolated, sink, type EN 61131-2 type 1
- Input for commutation or position feedback.
- Input for Electronic Gearing, (→ # 139)
- Mating connector data (→ # 54).

#### Wiring example

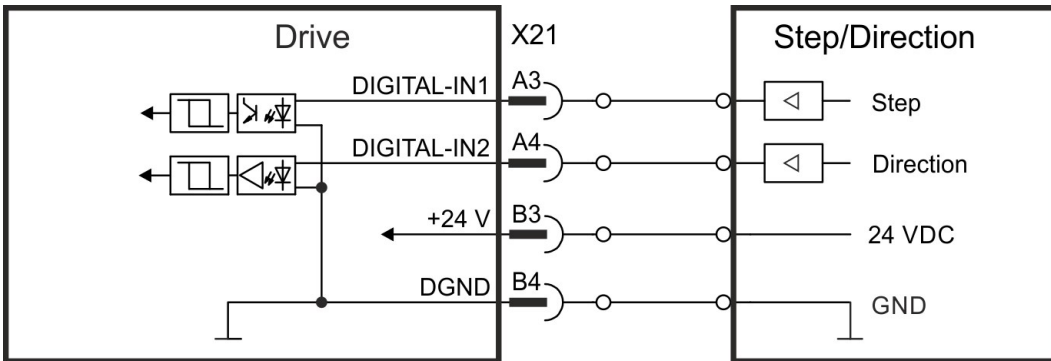

X21 Pin	Step/Direction	CW/CCW	Incr. Encoder
A3	Step	CW	A
A4	Direction	CCW	B
B3	24 VDC	24 VDC	24 VDC
B4	Common (DGND)	Common (DGND)	Common (DGND)

### 8.10.8 Feedback Connector X22

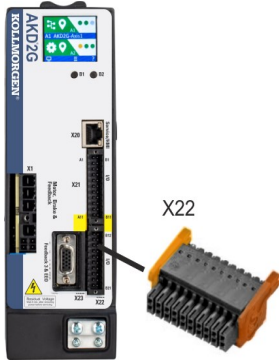

- Standard for dual axis drives, (→ # 28), optional for single axis drives
- 2 x 10 pins (left connector A, right connector B), pitch 3.5 mm
- RS485 inputs
- Input for commutation or position feedback.
- Input for Electronic Gearing, (→ # 139)
- Output for encoder emulation (EEO2), (→ # 139)
- Mating connector data (→ # 54).

#### Wiring example (Input)

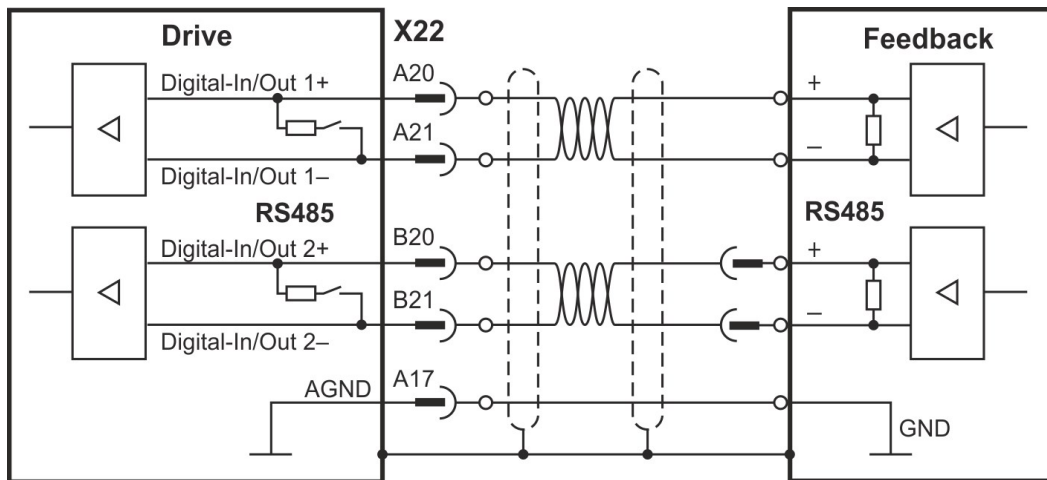

EEO output connection is similar.

X22 Pin	Step / Direction	CW / CCW	Increm. Encoder	BiSS C	EnDAT 2.2	SSI
A20	Step +	CW +	Track A +	CLK+	CLK+	CLK+
A21	Step -	CW -	Track A -	CLK-	CLK-	CLK-
B20	Direction +	CCW +	Track B +	DAT+	DAT+	DAT+
B21	Direction -	CCW -	Track B -	DAT-	DAT-	DAT-
A17	AGND	AGND	AGND	AGND	AGND	AGND

■ = DC Terminated, can be overridden with [DIO#.TERM](#)

**NOTE** Feedback power supply must be supplied and controlled by the user.

### 8.10.9 Feedback Connector X23

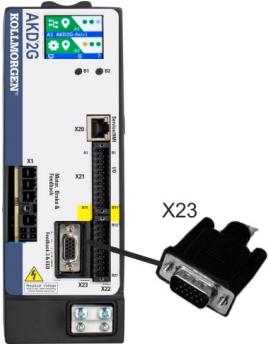

- Connectivity Option F3 or DX (→ # 28)
- Sub-D high density 15 pin, female
- Use Kollmorgen feedback cables
- Input for several feedback types
- Input for Electronic Gearing, (→ # 139)
- Output for encoder emulation (EEO1), (→ # 139)
- Digital input (→ # 154), Digital output (→ # 158)
- Mating connector data (→ # 54).

#### 8.10.9.1 X23 Connector Pinout Summary

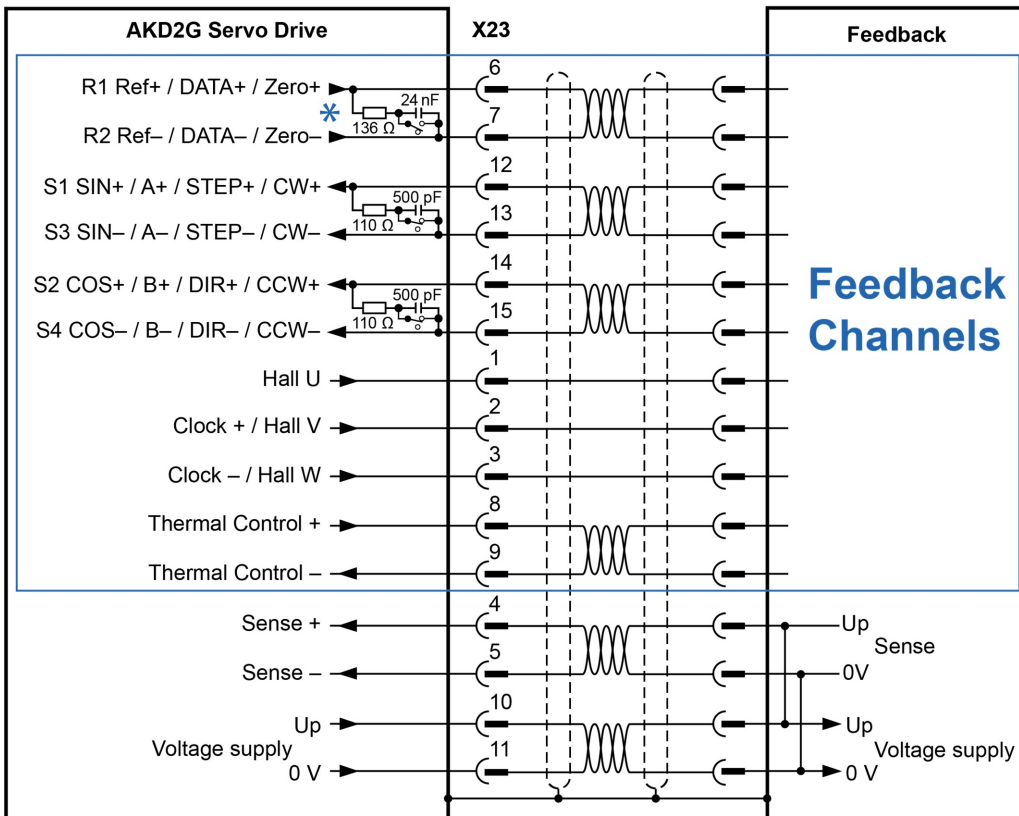

\* AC / DC Selectable Termination: Older drives may not include a DC termination switch across pins 6 and 7. Please contact Kollmorgen Support for more information

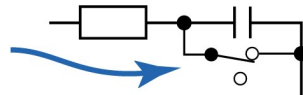

**Encoder power supply (X23 pins 10/11):**

- Maximum voltage 9 V with shorted sense contacts (4/5), rated voltage 5 V +/-3.5%.
- Rated supply current is 350 mA.
- Voltage rise time ~4 ms with full load and 220 µF of capacitance.
- Encoder power lines capacitance 10 µF to 220 µF

Pin	SFD	Resolver	BiSS		EnDat		HIPERFACE	Sin/ Cos	Sin/ +Hall	Incr. Enc.	Incr. +Hall	Hall	SSI	Step/ Dir	CW/ CCW
			B	C	2.1	2.2									
1	-	-	-	-	-	-	-	-	Hall U	-	Hall U	Hall U	-	-	-
2	-	-	CL+	CL+	CL+	CL+	-	-	Hall V	-	Hall V	Hall V	CL+	-	-
3	-	-	CL-	CL-	CL-	CL-	-	-	Hall W	-	Hall W	Hall W	CL-	-	-
4	S+	-	S+	S+	S+	S+	S+	S+	S+	S+	S+	-	-	-	-
5	S-	-	S-	S-	S-	S-	S-	S-	S-	S-	S-	-	-	-	-
6	COM+	R1 Ref+	D+	D+	D+	D+	D+	Z+	Z+	Z+	Z+	-	D+	-	-
7	COM-	R2 Ref-	D-	D-	D-	D-	D-	Z-	Z-	Z-	Z-	-	D-	-	-
8	-	Th+	Th+	-	Th+	-	Th+	Th+	Th+	Th+	Th+	Th+	Th+	Th+	Th+
9	-	Th-	Th-	-	Th-	-	Th-	Th-	Th-	Th-	Th-	Th-	Th-	Th-	Th-
10	+5 V	-	+5 V	+5 V	+5 V	+5 V	8 to 9 V	+5 V	+5 V	+5 V	+5 V	+5 V	+5 V	+5 V	+5 V
11	0 V	-	0 V	0 V	0 V	0 V	0 V	0 V	0 V	0 V	0 V	0 V	0 V	0 V	0 V
12	-	S1 SIN+	A+	-	A+	-	SIN+	A+	SIN+	A+	A+	-	-	Step+	CW+
13	-	S3 SIN-	A-	-	A-	-	SIN-	A-	SIN-	A-	A-	-	-	Step-	CW-
14	-	S2 COS+	B+	-	B+	-	COS+	B+	COS+	B+	B+	-	-	Dir+	CCW+
15	-	S4 COS-	B-	-	B-	-	COS-	B-	COS-	B-	B-	-	-	Dir-	CCW-

CL = CLOCK, D = DATA, S = SENSE, Th = Thermal control, Z = Zero

  = DC Terminated, can be overridden with [DIO#.TERM](#)

  = Optional

### 8.10.10 X23 Feedback Wiring Pinout Diagrams

#### 8.10.10.1 X23 SFD Feedback

The diagram below shows the connection of the four-wire Kollmorgen SFD feedback system.

**NOTE**

When SFD cable total resistance for 5V out (Up) and 5V return (0V) is less than 3.3 Ohm, then remote sensing is not needed. For a typical cable this means remote sensing is not needed up to 25m.

Kollmorgen cables are rated up to 50m with no remote sensing.

Type	FBx.IDENTIFIED	Up	Description
Smart Feedback Device (SFD)	41	5.1 V $\pm$ 3.5%	Accuracy: 14 bit (0.022°), resolution: 24 bit (2x10E-5°)

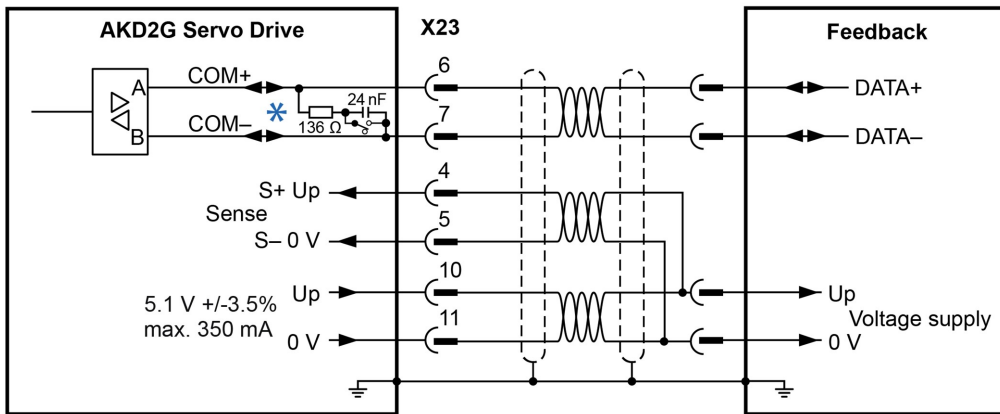

\* SFD must always use AC coupled termination - DC termination switch open.

### 8.10.10.2 X23 Resolver Feedback

The diagram below shows the connection of a resolver (2 to 36-poles) as a feedback system. The thermal control in the motor is connected via the Resolver cable and evaluated in the drive. If no thermal control is in the motor, the cable must short pins 8 and 9.

If cable lengths of more than 100m are planned, please contact customer support.

Type	FBx.INDENTIFIED	Description
Resolver	40	Accuracy: 14 bit (0.022°), resolution: 16 bit (0.006°), frequency (fixed): 6875 Hz

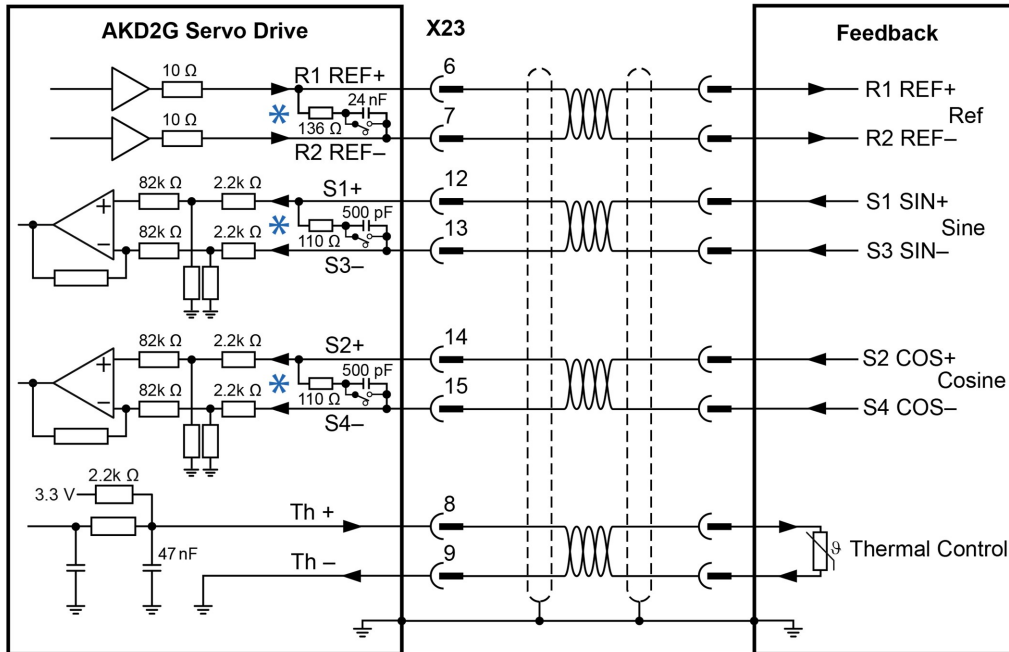

- \* Resolver Sine/Cosine channels must be high impedance - DC termination switch open.
- \* DC termination is not compatible with the REF channel - DC termination switch open.

### 8.10.10.3 X23 BiSS (Mode B) Analog Feedback

The diagram below shows the wiring of a single-turn or multi-turn encoder with BiSS Mode B interface as a feedback system. The thermal control in the motor is connected via the encoder cable and evaluated in the drive.

If cable lengths of more than 50m are planned, please consult customer support.

Type	FBx.INDENTIFIED	Up	Frequency Limit
BiSS (Mode B) Analog	32	5.1 V $\pm$ 3.5%	1 MHz, 250 kHz for encoders that require termination resistors

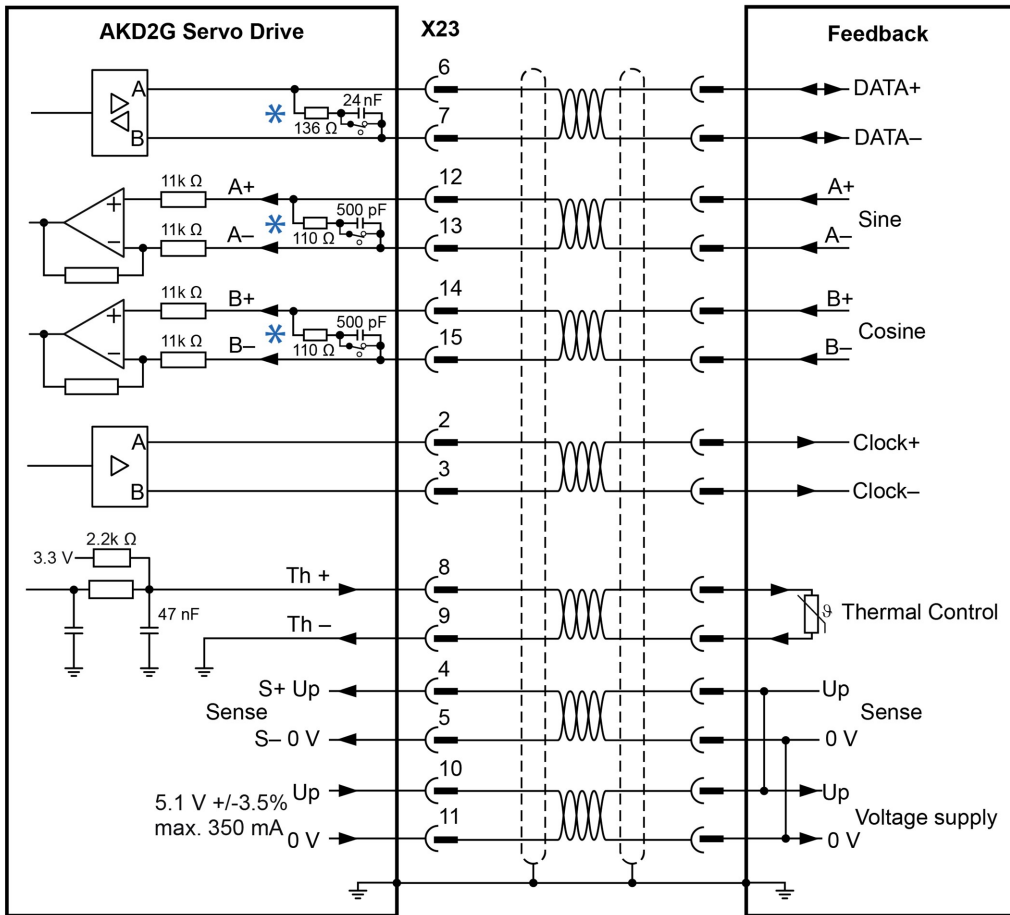

\* DC terminated by default - DC switch closed.



### 8.10.10.4 X23 BiSS (Mode C) Digital Feedback

The diagram below shows the wiring of a single-turn or multi-turn encoder with BiSS Mode C interface from Renishaw (specifically model Resolute RA26B) as a feedback system.

If cable lengths of more than 25m are planned, please consult customer support.

Type	FBx.INDENTIFIED	Up	Frequency Limit
BiSS (Mode C) Digital	34	5.1 V $\pm$ 3.5%	1 MHz

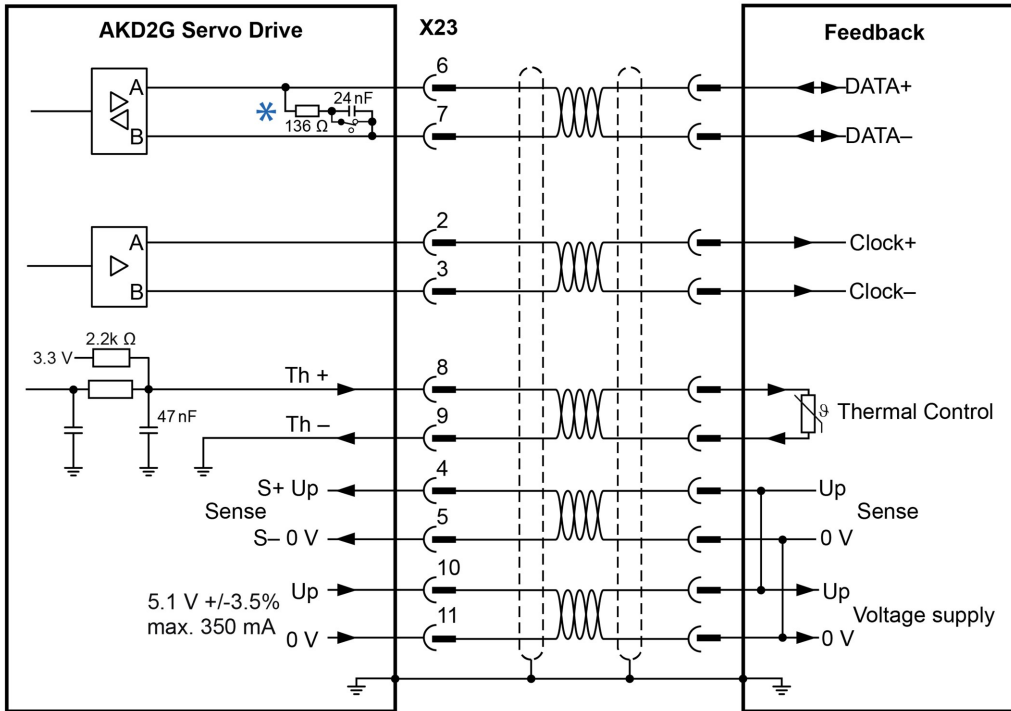

\* DC terminated by default - DC switch closed.

**8.10.10.5 X23 EnDAT 2.1 Feedback (with 1V p-p analog signals)**

The diagram below shows the wiring of a single-turn or multi-turn sine-cosine encoder with EnDat 2.1 interface as a feedback system. Preferred types are the ECN1313 and EQN1325 encoders. The thermal control in the motor is connected via the encoder cable and evaluated in the drive. All signals are connected using our pre-assembled encoder connection cable.

If cable lengths of more than 50m are planned, please consult customer support.

Type	FBx.INDENTIFIED	Frequency Limit
EnDAT 2.1	30	1 MHz, 250 kHz for encoders that require termination resistors

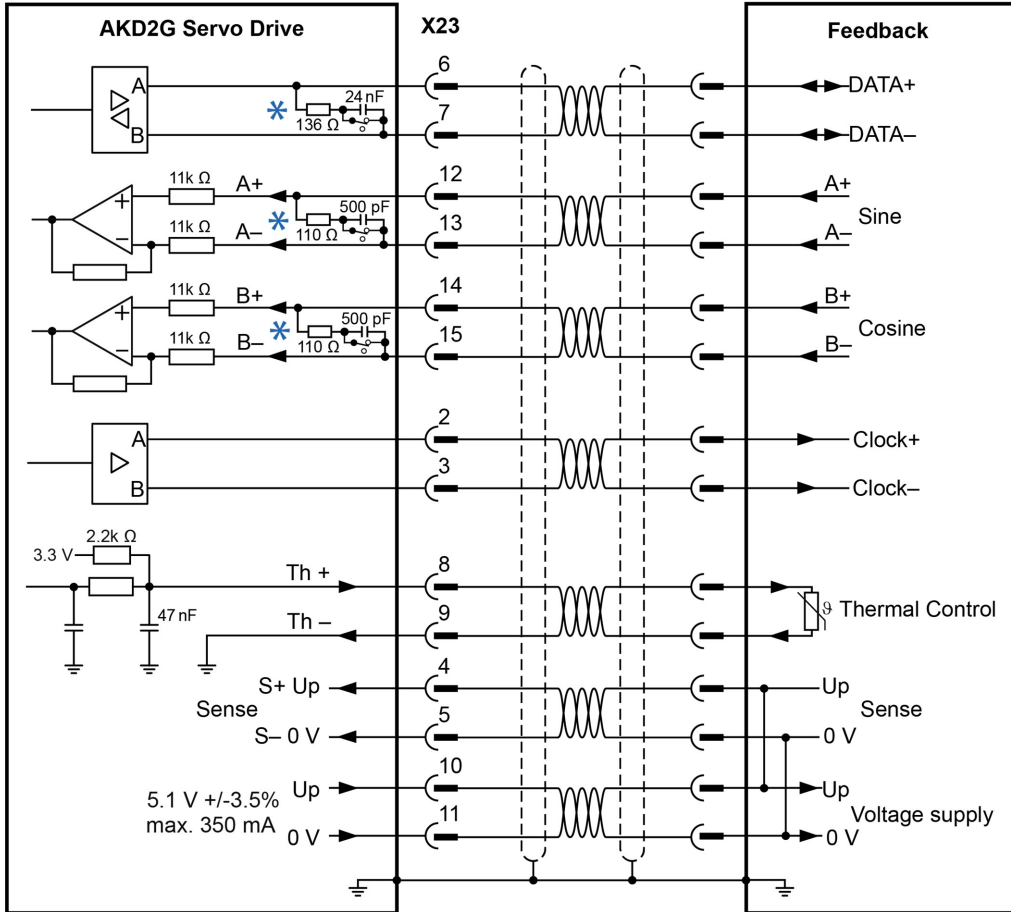

\* DC terminated by default - DC switch closed.

### 8.10.10.6 X23 EnDAT 2.2 Digital Feedback

Single-turn or multi-turn encoders with EnDat 2.2 interface can be connected either to X23 or X41 as a primary motor feedback system.

All signals are connected using our pre-assembled encoder connection cable.

If cable lengths of more than 50m are planned, please consult customer support.

Type	FBx.INDENTIFIED	Frequency Limit
EnDAT 2.2	31	2.5 MHz

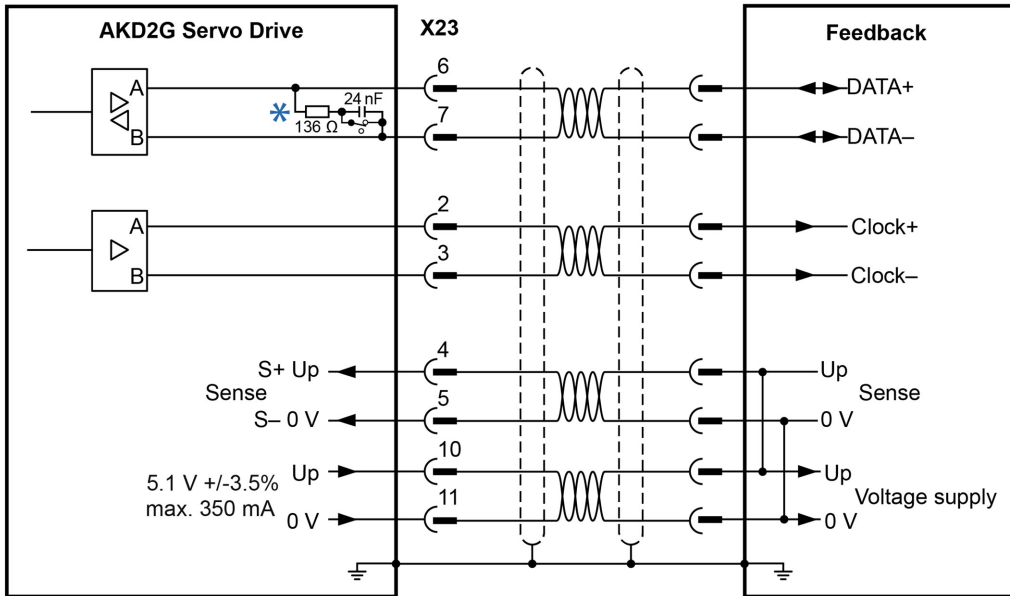

\* DC terminated by default - DC switch closed.

**NOTE**

From -: Analog I/O functionality must be selected in the related WorkBench screen.  
If the set limit is exceeded, then warning n256 is created.

\*For use as primary motor feedback, set parameters DRV.EMUEMODE, PL.FBSOURCE, IL.FBSOURCE, VL.FBSOURCE.

### 8.10.10.7 X23 HIPERFACE Feedback

The diagram below shows the wiring of a single-turn or multi-turn sine-cosine encoder with Hiperface interface as a feedback system.

The thermal control in the motor is connected via the encoder cable and evaluated in the drive. All signals are connected using our pre-assembled encoder connection cable.

If cable lengths of more than 50 m are planned, please consult customer support.

Type	FBx.INDENTIFIED	Frequency Limit
HIPERFACE	33	1 MHz, 250 kHz for encoders that require termination resistors

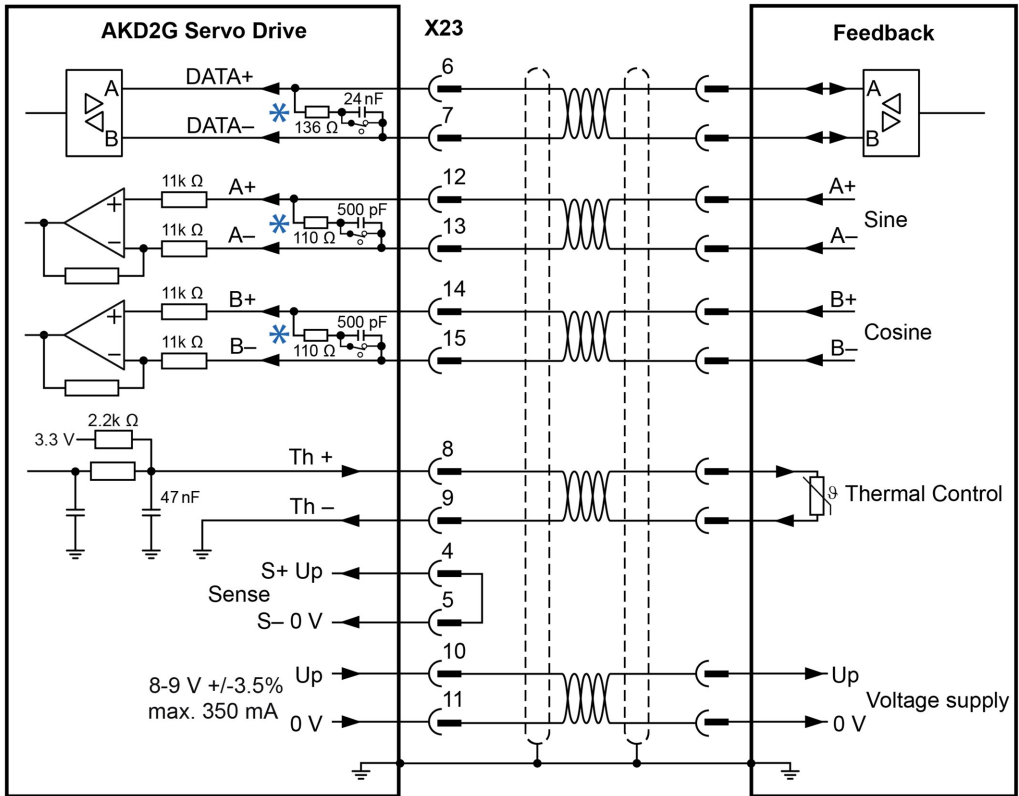

\* DC terminated by default - DC switch closed.

**NOTE** Connecting pin 4 and 5 together causes Up to be 8 to 9V.

### 8.10.10.8 X23 Sine Encoder Feedback

This feedback device does not deliver absolute information for commutation and works with wake&shake commutation (WorkBench Online Help). All signals are connected to X23 / X41 and evaluated there.

If cable lengths of more than 25m are planned, please consult customer support.

Type	FBx.INDENTIFIED	Up	Frequency Limit
SinCos 1 V p-p (Wake & Shake)	21	5.1 V ± 3.5%	1 MHz, 250 kHz for encoders that require termination resistors

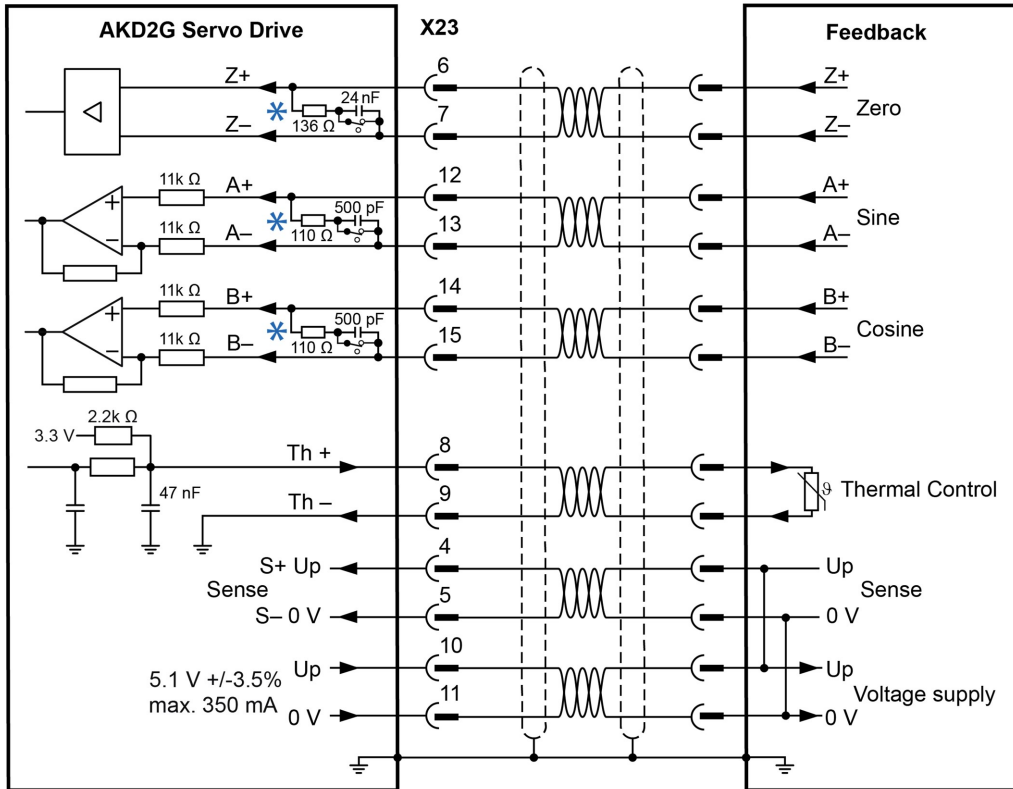

\* DC terminated by default - DC switch closed.

### 8.10.10.9 X23 Sine Encoder with Hall Feedback

This feedback device delivers absolute information for commutation and can be used as a complete feedback system. All signals are connected to X23 / X41 and evaluated there.

If cable lengths of more than 25m are planned, please consult customer support.

Type	FBx.INDENTIFIED	Up	Frequency Limit
SinCos 1 V p-p with Hall	20	5.1V ± 3.5%	1 MHz, 250 kHz for encoders that require termination resistors

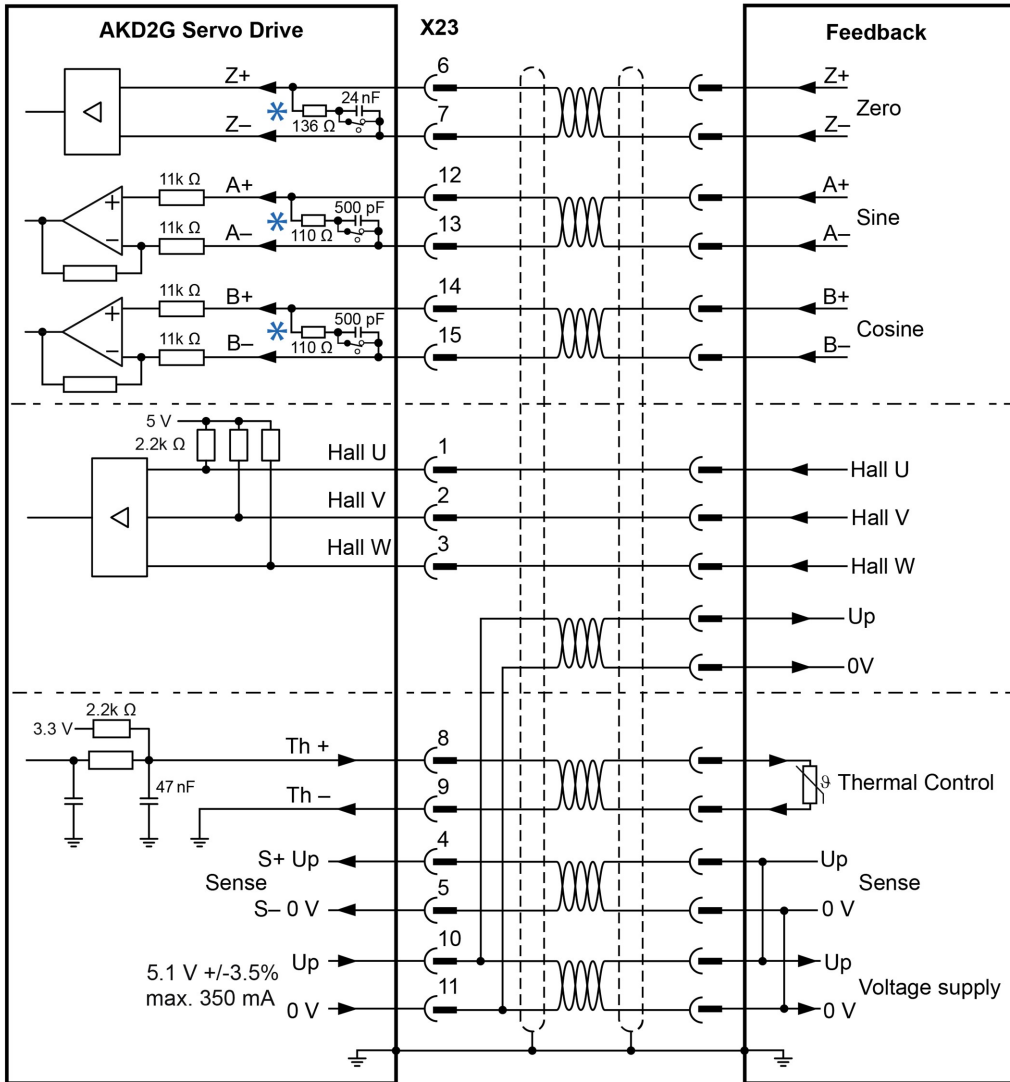

\* DC terminated by default - DC switch closed.

### 8.10.10.10 X23 Incremental Encoder Feedback

This feedback device does not deliver absolute information for commutation and works with Wake and Shake commutation (see WorkBench Online Help). All signals are connected using a pre-assembled comcoder connection cable. The thermal control in the motor is connected via the encoder cable and evaluated in the drive.

If cable lengths of more than 25m are planned, please consult customer support.

Type	FBx.INDENTIFIED	Up	Frequency Limit
Incremental Encoder (Wake and Shake)	11	5.1V ± 3.5%	2.5 MHz

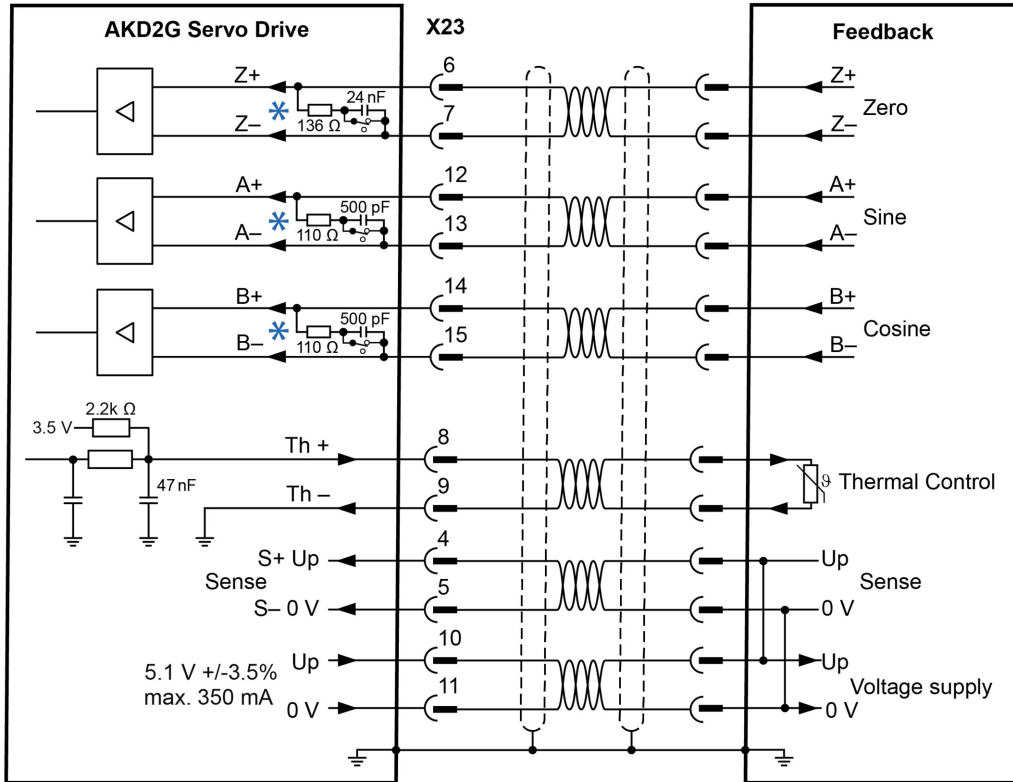

\* DC terminated by default - DC switch closed.

### 8.10.10.11 X23 Incremental Encoder with Hall Feedback

This feedback device delivers absolute information for commutation and can be used as a complete feedback system. All signals are connected using a pre-assembled comcoder connection cable. The thermal control in the motor is connected via the encoder cable and evaluated in the drive.

If cable lengths of more than 25m are planned, please consult customer support.

Type	FBx.INDENTIFIED	Up	Frequency Limit
Incremental Encoder with Hall Switches (Comcoder)	10	5.1V ± 3.5%	2.5 MHz

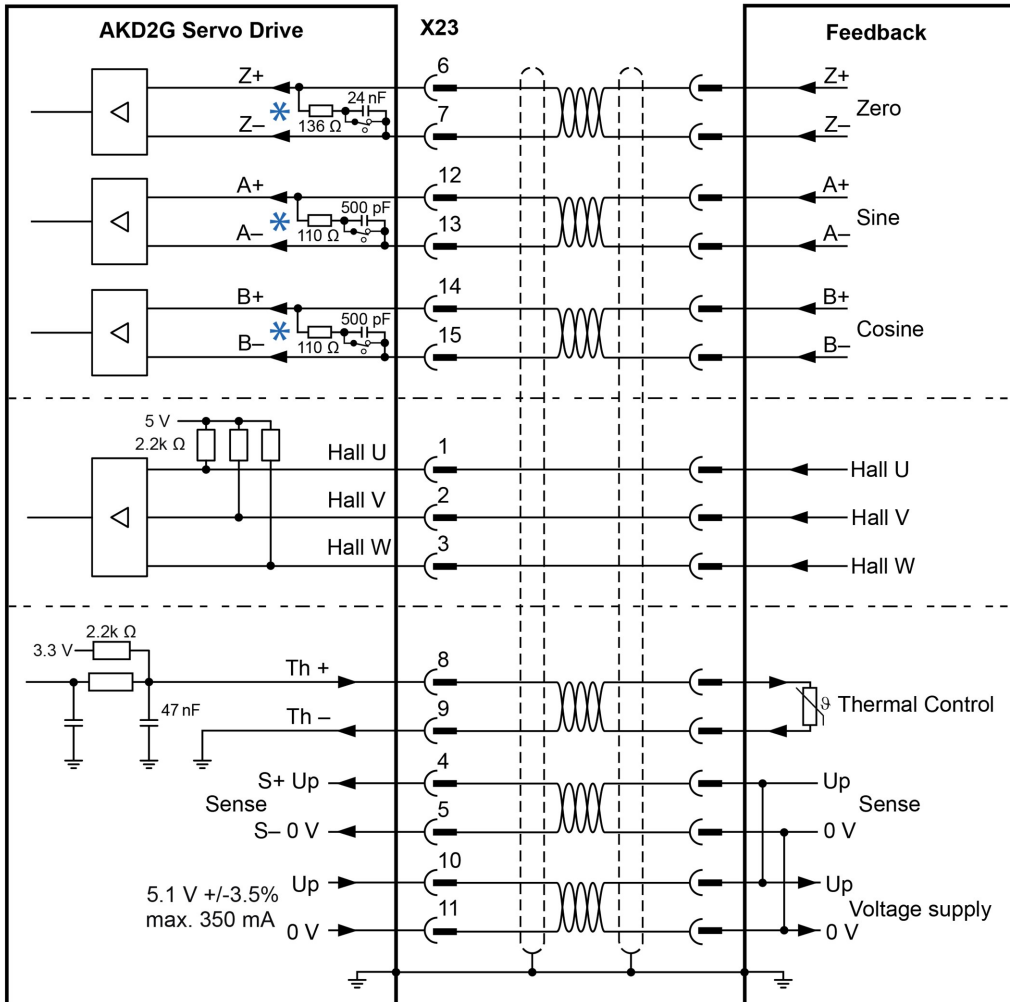

\* DC terminated by default - DC switch closed.



### 8.10.10.12 X23 Hall Feedback

This feedback type only supports operating in Torque mode and Velocity mode.

If cable lengths of more than 25m are planned, please consult customer support.

Type	FBx.INDENTIFIED	Up	Frequency Limit
Hall Only	12	5.1V ± 3.5%	1 MHz

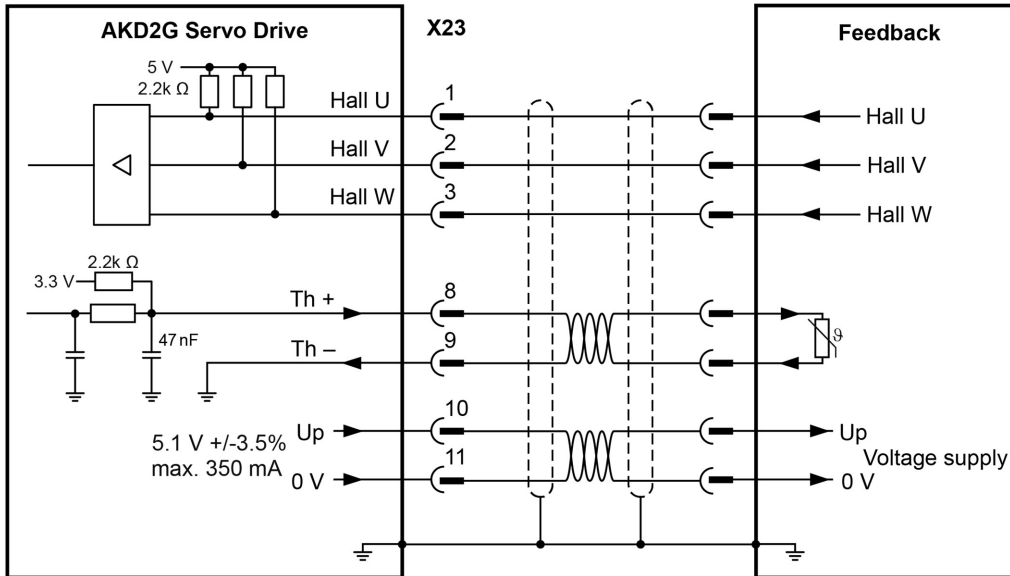

For more information concerning Hall feedback setting refer to WorkBench Online Help.

### 8.10.10.13 X23 SSI Feedback

Synchronous Serial Interface (SSI) is a standard industrial serial interface based on RS-422 standards.

If cable lengths of more than 25m are planned, please consult customer support.

Type	FBx.INDENTIFIED	Up	Frequency Limit
SSI (Synchronous Serial Interface)	36	5.1V ± 3.5%	1 MHz

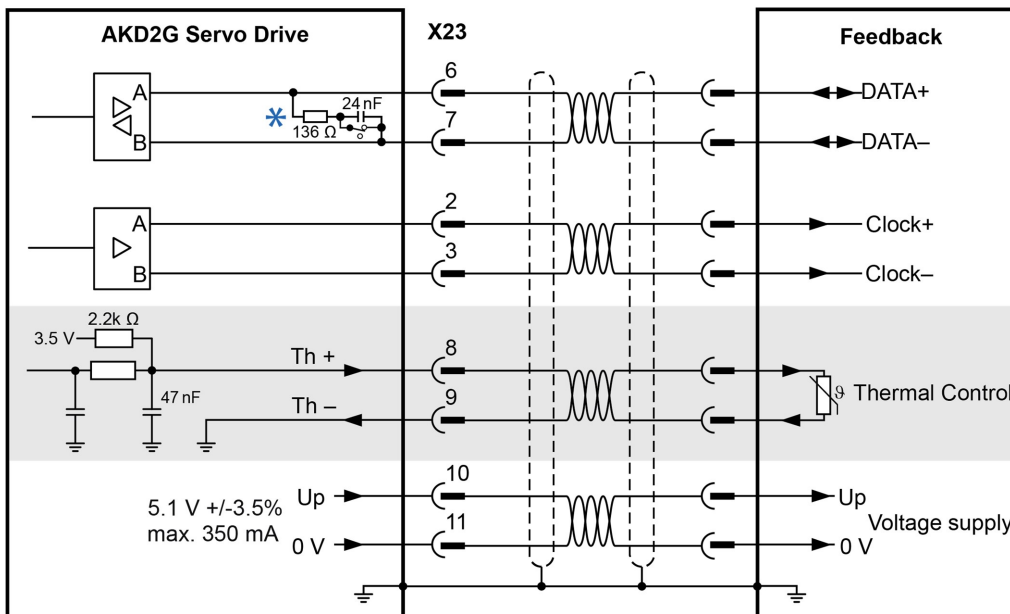

\* DC terminated by default - DC switch closed.

■ Optional

### 8.10.10.14 X23 Step / Direction and CW / CCW Feedback

These feedback options are intended to be used by controllers to provide an Electronic Gearing source signal. If cable lengths of more than 25m are planned, please consult customer support.

Type	FBx.INDENTIFIED	Up	Frequency Limit
Step / Direction	13	5.1V ± 3.5%	1 MHz
CW / CCW	14	5.1V ± 3.5%	

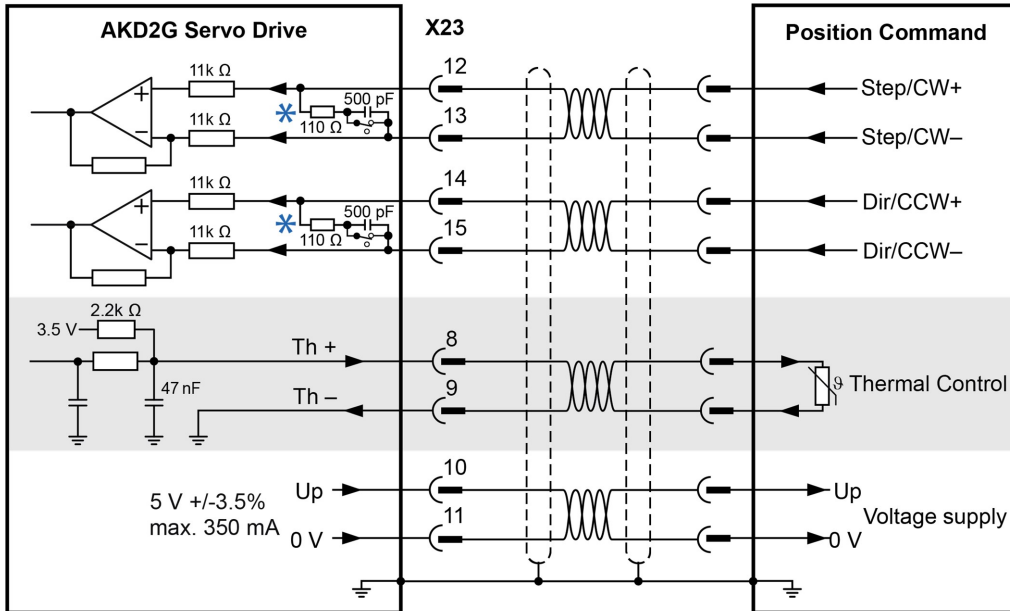

\* DC terminated by default - DC switch closed.

■ Optional

### 8.10.11 Feedback Connector X41 (SFA, accessory)

SFA (Smart Feedback Adapter) converts conventional feedback signals to a 2-wire serial signal. SFA can be laid into the cable duct or may be mounted to a DIN rail using a standard DIN rail clip.

SFA provides a 15 pole HD Sub-D female connector X41 to the system for connection of a Kollmorgen motor feedback cable (see *Kollmorgen 2G Cable Guide*). Dimensions (LxWxD): 88.6 x 55.6 x 21.2 (28.6 with rail clip). Order codes see regional Accessories Manual.

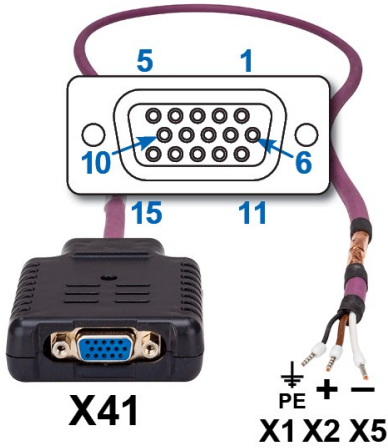

- Sub-D high density 15 pin, female
- 1 m shielded cable with 3 flying leads for connection to X1 or X2 or X5
- The cable shield is connected by using shield wire to X5/1 or with cable ties to the X1/X2 shield plates.
- Connected feedback must be set in WorkBench.
- Only use Kollmorgen feedback cables. The cable shield must be grounded on the end near the SFA.
- SFA models with a metal DIN clip must be mounted inside a cabinet.
- Input for Electronic Gearing, (→ # 139)
- Output for encoder emulation (EXX3/EXX4), (→ # 139) - Only available on "-EXX" (Encoder) models
- Master-Slave (→ # 141)

Connect the flying leads of the SFA cable to X1 (FB1, EXX3) or X2 (FB2, EXX4) or X5 (FB2, EXX4):

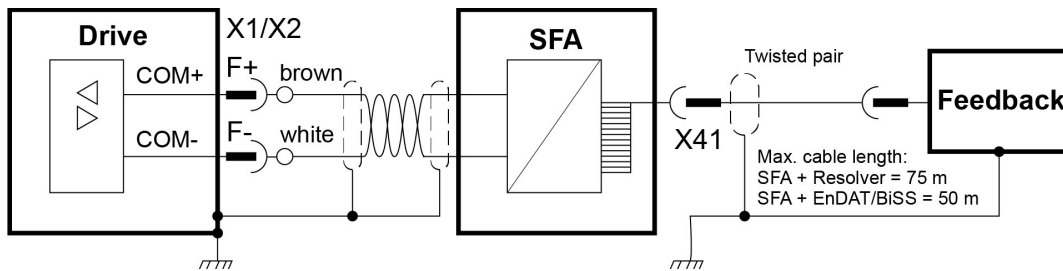

### 8.10.11.1 X41 Connector Pinout Summary

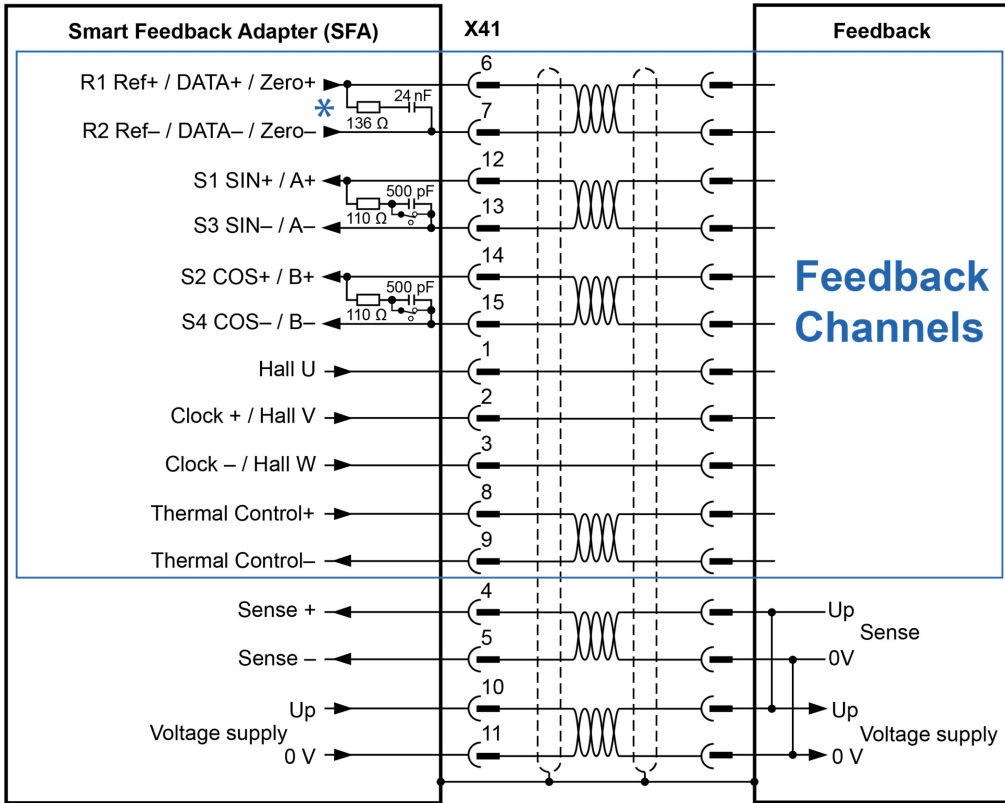

\* The SFA does not include a DC termination switch across pins 6 and 7.

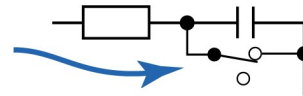

Operating Voltage: 7 to 12V, Maximum Load Current: 350mA

X41 Pin	SFD	Resolver (1)	BiSS		EnDat		HIPEFACE	Sin / Cos	Sin / Cos +Hall	Incr. Enc.	Incr. Enc. +Hall	Hall	SSI
			B	C	2.1	2.2							
1	-	-	-	-	-	-	-	-	Hall U	-	Hall U	Hall U	-
2	-	-	CL+	CL+	CL+	CL+	-	-	Hall V	-	Hall V	Hall V	CL+
3	-	-	CL-	CL-	CL-	CL-	-	-	Hall W	-	Hall W	Hall W	CL-
4	S+	-	S+	S+	S+	S+	S+	S+	S+	S+	S+	-	-
5	S-	-	S-	S-	S-	S-	S-	S-	S-	S-	S-	-	-
6	COM+	R1 Ref+	D+	D+	D+	D+	D+	Z+	Z+	Z+	Z+	-	D+
7	COM-	R2 Ref-	D-	D-	D-	D-	D-	Z-	Z-	Z-	Z-	-	D-
8	-	Th+	Th+	-	Th+	-	Th+	Th+	Th+	Th+	Th+	Th+	Th+
9	-	Th-	Th-	-	Th-	-	Th-	Th-	Th-	Th-	Th-	Th-	Th-
10	+5 V	-	+5 V	+5 V	+5 V	+5 V	8 to 9 V	+5 V	+5 V	+5 V	+5 V	+5 V	+5 V
11	0 V	-	0 V	0 V	0 V	0 V	0 V	0 V	0 V	0 V	0 V	0 V	0 V
12	-	S1 SIN+	A+	-	A+	-	SIN+	A+	SIN+	A+	A+	-	-
13	-	S3 SIN-	A-	-	A-	-	SIN-	A-	SIN-	A-	A-	-	-
14	-	S2 COS+	B+	-	B+	-	COS+	B+	COS+	B+	B+	-	-
15	-	S4 COS-	B-	-	B-	-	COS-	B-	COS-	B-	B-	-	-

CL = CLOCK, D = DATA, S = SENSE, Th = Thermal control, Z = Zero

(1) : Resolver with AKD2G-CON-SFA-R00 only, all other feedback devices with AKD2G-CON-SFA-E00 only

  = DC Terminated, can be overridden with [DIO#.TERM](#)

  = Optional

### 8.10.12 X41 Feedback Wiring Pinout Diagrams

#### 8.10.12.1 X41 SFD Feedback

The diagram below shows the connection of the four-wire Kollmorgen SFD feedback system.

**NOTE**

When SFD cable total resistance for 5V out (Up) and 5V return (0V) is less than 3.3 Ohm, then remote sensing is not needed. For a typical cable this means remote sensing is not needed up to 25m.

Kollmorgen cables are rated up to 50m with no remote sensing.

Type	FBx.INDENTIFIED	Up	Description
Smart Feedback Device (SFD)	141	5.1 V ± 3.5%	Accuracy: 14 bit (0.022°), resolution: 24 bit (2x10E-5°)

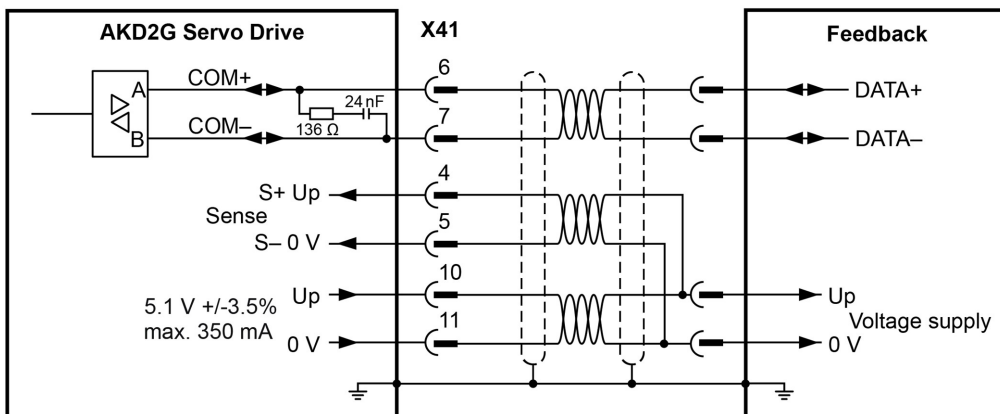

### 8.10.12.2 X41 Resolver Feedback

The diagram below shows the connection of a resolver (2 to 36-poles) as a feedback system. The thermal control in the motor is connected via the Resolver cable and evaluated in the drive. If no thermal control is in the motor, the cable must short pins 8 and 9.

If cable lengths of more than 100m are planned, please contact customer support.

Type	FBx.INDENTIFIED	Description
Resolver	140	Accuracy: 14 bit (0.022°), resolution: 16 bit (0.006°), frequency (fixed): 6875 Hz

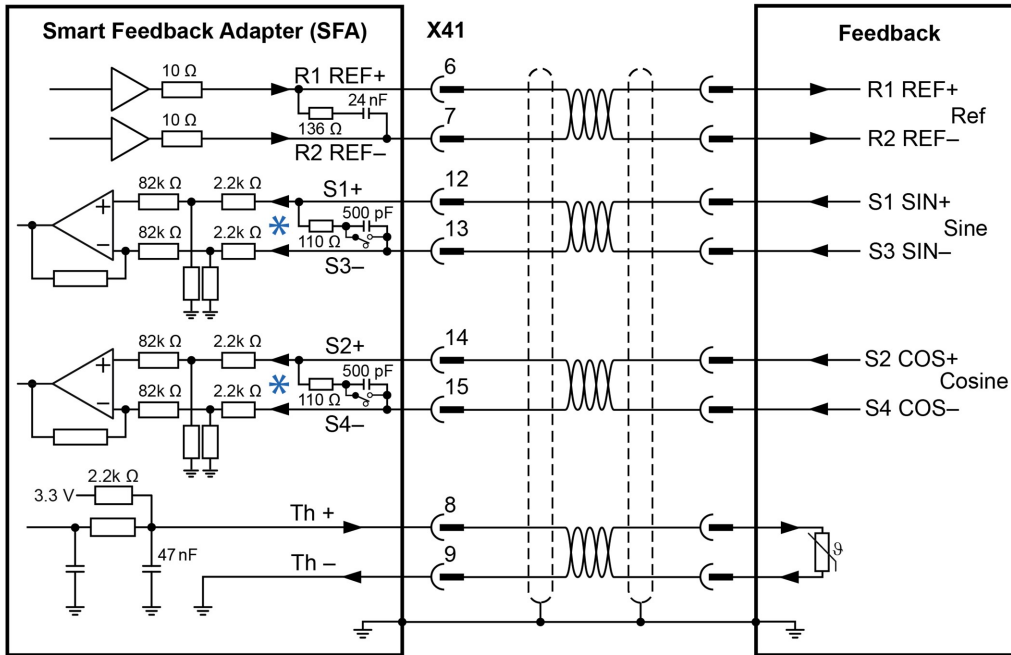

\* Resolver Sine/Cosine channels must be high impedance - DC termination switch open.

### 8.10.12.3 X41 BiSS (Mode B) Analog Feedback

The diagram below shows the wiring of a single-turn or multi-turn encoder with BiSS Mode B interface as a feedback system. The thermal control in the motor is connected via the encoder cable and evaluated in the drive.

If cable lengths of more than 50m are planned, please consult customer support.

Type	FBx.INDENTIFIED	Up	Frequency Limit
BiSS (Mode B) Analog	132	5.1V ± 3.5%	1 MHz, 250 kHz for encoders that require termination resistors

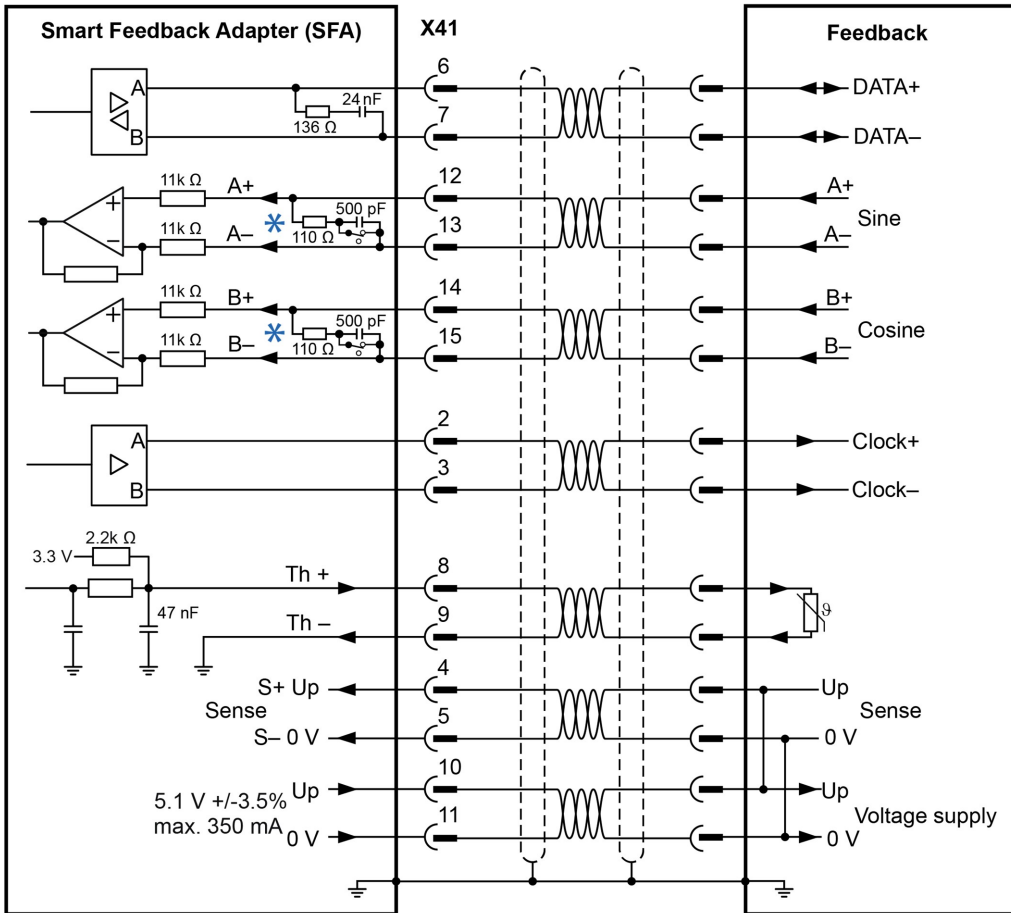

\* DC terminated by default - DC switch closed.

### 8.10.12.4 X41 BiSS (Mode C) Digital Feedback

The diagram below shows the wiring of a single-turn or multi-turn encoder with BiSS Mode C interface from Renishaw (specifically model Resolute RA26B) as a feedback system.

If cable lengths of more than 25m are planned, please consult customer support.

Type	FBx.INDENTIFIED	Up	Frequency Limit
BiSS (Mode C) Digital	134	5.1V ± 3.5%	1 MHz

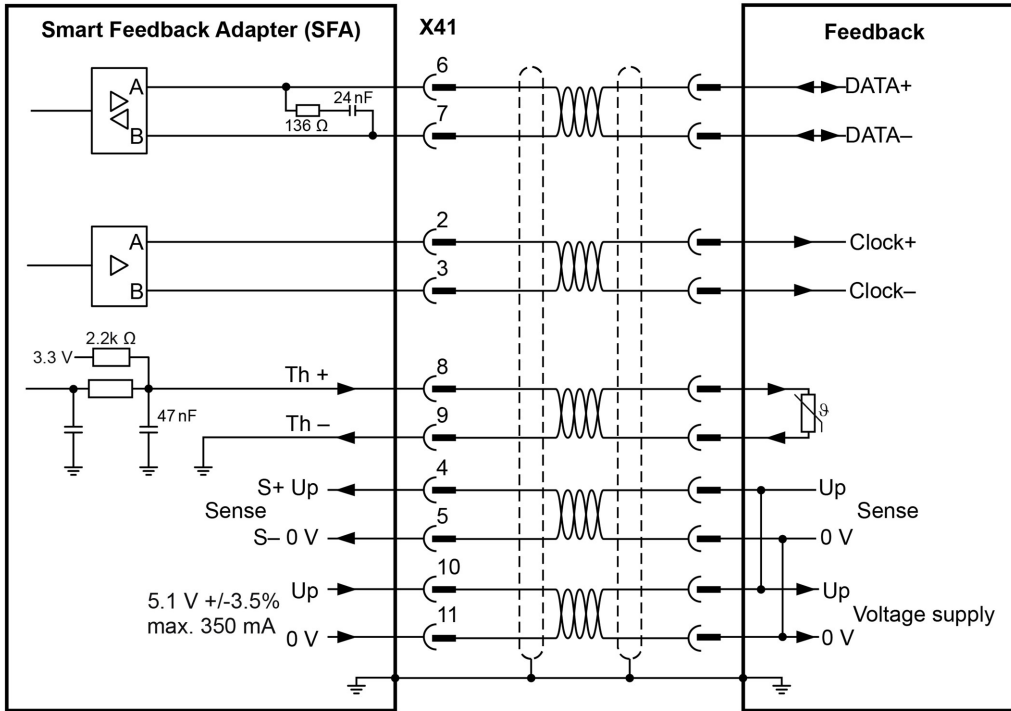



### 8.10.12.5 X41 EnDAT 2.1 Feedback (with 1 V p-p analog signals)

The diagram below shows the wiring of a single-turn or multi-turn sine-cosine encoder with EnDat 2.1 interface as a feedback system. Preferred types are the ECN1313 and EQN1325 encoders. The thermal control in the motor is connected via the encoder cable and evaluated in the drive. All signals are connected using our pre-assembled encoder connection cable.

If cable lengths of more than 50m are planned, please consult customer support.

Type	FBx.INDENTIFIED	Frequency Limit
EnDAT 2.1	130	1 MHz, 250 kHz for encoders that require termination resistors

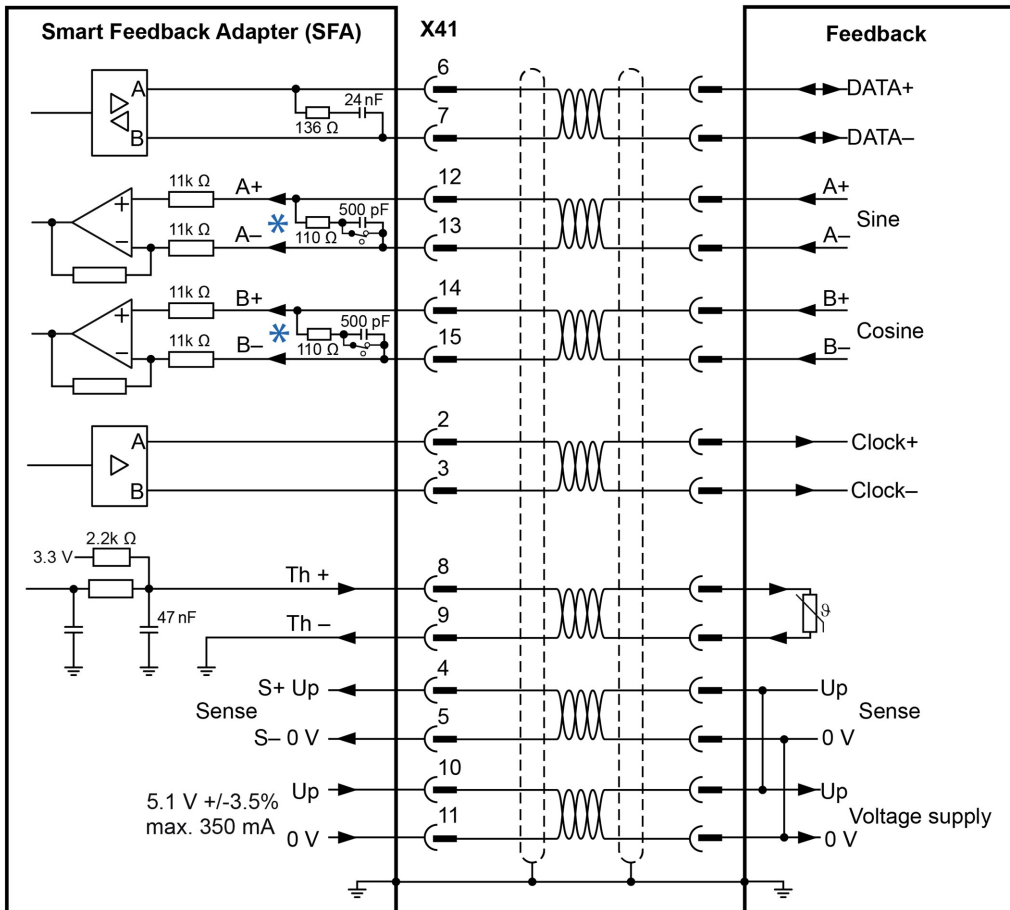

\* DC terminated by default - DC switch closed.

### 8.10.12.6 X41 EnDAT 2.2 Digital Feedback

Single-turn or multi-turn encoders with EnDat 2.2 interface can be connected either to X23 or X41 as a primary motor feedback system.

All signals are connected using our pre-assembled encoder connection cable.

If cable lengths of more than 50m are planned, please consult customer support.

Type	FBx.INDENTIFIED	Frequency Limit
EnDAT 2.2	131	2.5 MHz

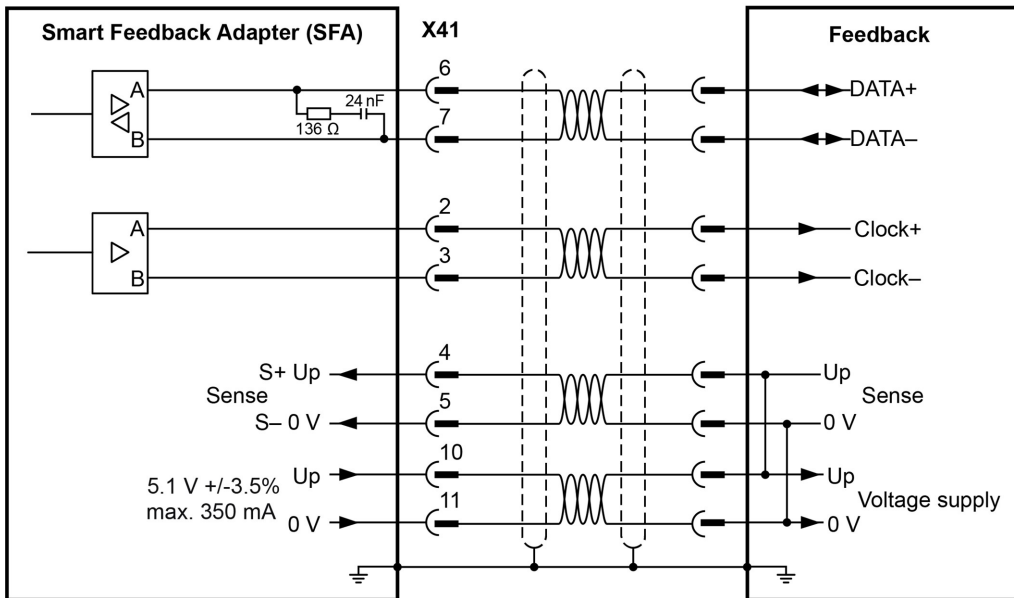

From -: Analog I/O functionality must be selected in the related WorkBench screen.  
If the set limit is exceeded, then warning n256 is created.

**NOTE**

\*For use as primary motor feedback, set parameters DRV.EMUEMODE, PL.FBSOURCE, IL.FBSOURCE, VL.FBSOURCE.

### 8.10.12.7 X41 HIPERFACE Feedback

The diagram below shows the wiring of a single-turn or multi-turn sine-cosine encoder with Hiperface interface as a feedback system.

The thermal control in the motor is connected via the encoder cable and evaluated in the drive. All signals are connected using our pre-assembled encoder connection cable.

If cable lengths of more than 50m are planned, please consult customer support.

Type	FBx.INDENTIFIED	Frequency Limit
HIPERFACE	133	1 MHz, 250 kHz for encoders that require termination resistors

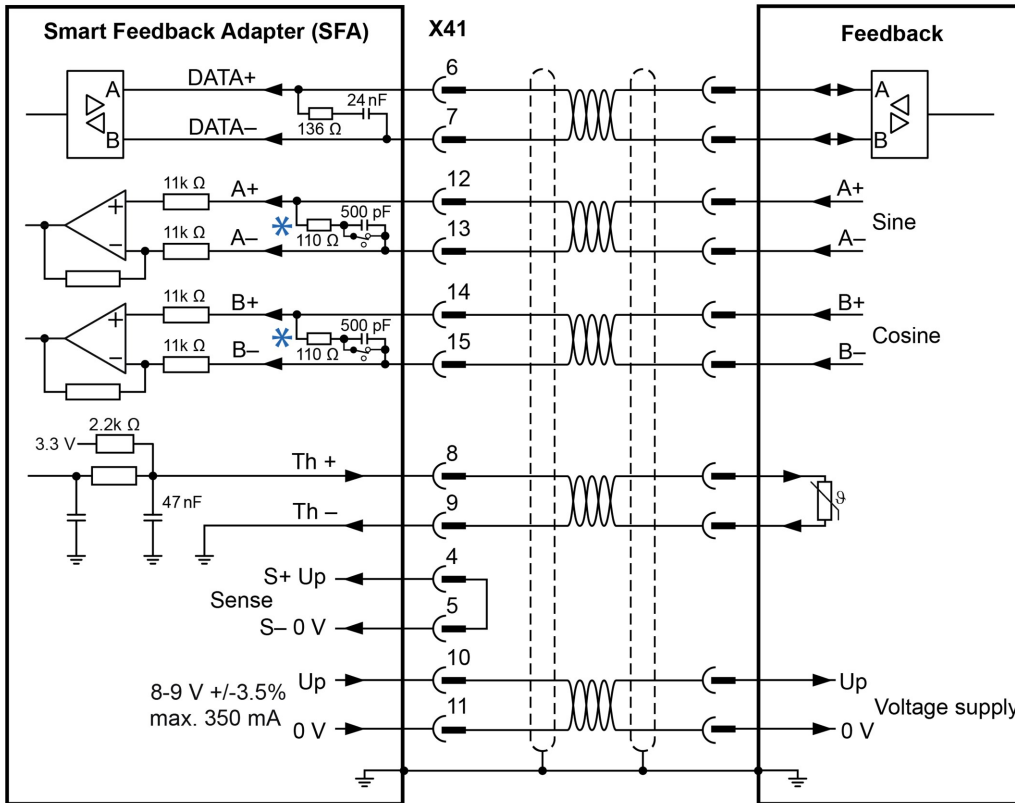

\* DC terminated by default - DC switch closed.

**NOTE** Connecting pin 4 and 5 together causes Up to be 8 to 9 V.

### 8.10.12.8 X41 Sine Encoder Feedback

This feedback device does not deliver absolute information for commutation and works with Wake&Shake commutation (WorkBench Online Help). All signals are connected to X23 / X41 and evaluated there.

If cable lengths of more than 25m are planned, please consult customer support.

Type	FBx.INDENTIFIED	Up	Frequency Limit
SinCos 1 V p-p (Wake & Shake)	121	5.1V ± 3.5%	1 MHz, 250 kHz for encoders that require termination resistors

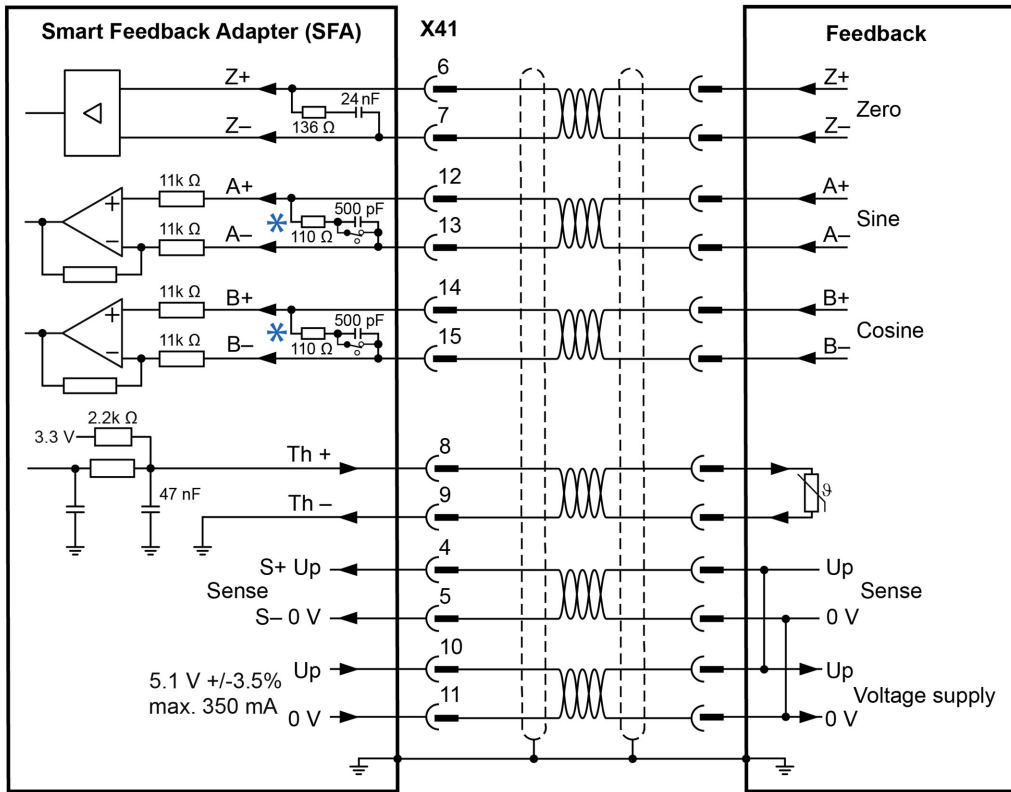

\* DC terminated by default - DC switch closed.

### 8.10.12.9 X41 Sine Encoder with Hall Feedback

This feedback device delivers absolute information for commutation and can be used as a complete feedback system. All signals are connected to X23 / X41 and evaluated there.

If cable lengths of more than 25m are planned, please consult customer support.

Type	FBx.INDENTIFIED	Up	Frequency Limit
SinCos 1 V p-p with Hall	120	5.1V ± 3.5%	1 MHz, 250 kHz for encoders that require termination resistors

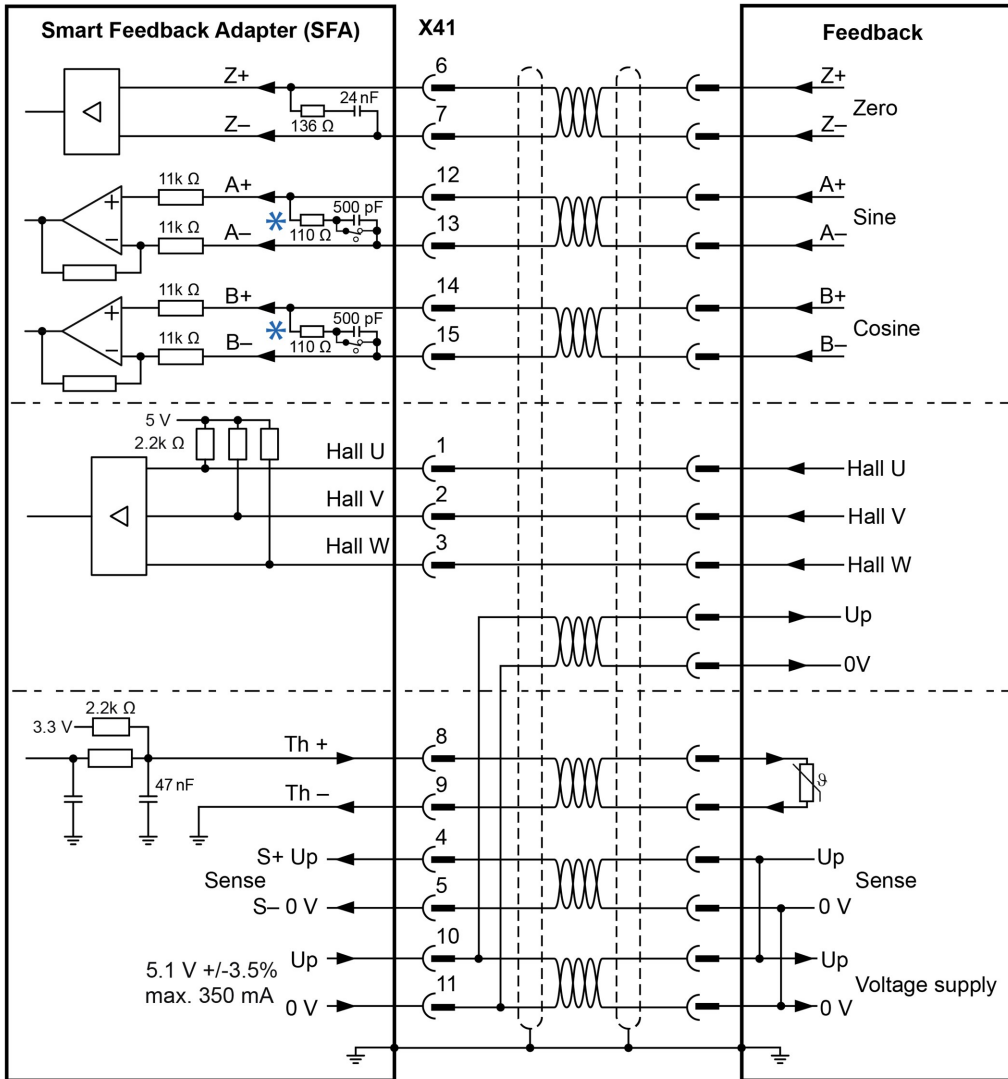

\* DC terminated by default - DC switch closed.

**8.10.12.10 X41 Incremental Encoder Feedback**

This feedback device does not deliver absolute information for commutation and works with Wake&Shake commutation (see WorkBench Online Help). All signals are connected using a pre-assembled comcoder connection cable. The thermal control in the motor is connected via the encoder cable and evaluated in the drive.

If cable lengths of more than 25m are planned, please consult customer support.

Type	FBx.INDENTIFIED	Up	Frequency Limit
Incremental Encoder (Wake and Shake)	111	5.1V ± 3.5%	2.5 MHz

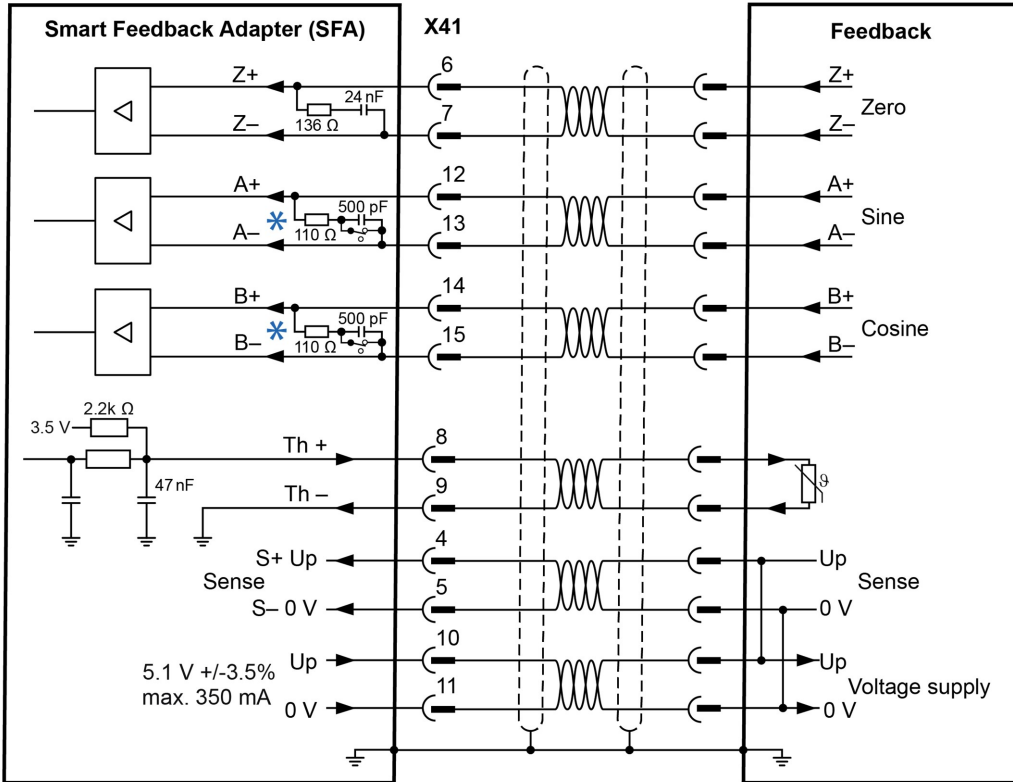

\* DC terminated by default - DC switch closed.

### 8.10.12.11 X41 Incremental Encoder with Hall Feedback

This feedback device delivers absolute information for commutation and can be used as a complete feedback system. All signals are connected using a pre-assembled comcoder connection cable. The thermal control in the motor is connected via the encoder cable and evaluated in the drive.

If cable lengths of more than 25m are planned, please consult customer support.

Type	FBx.INDENTIFIED	Up	Frequency Limit
Incremental Encoder with Hall Switches (Comcoder)	110	5.1V ± 3.5%	2.5 MHz

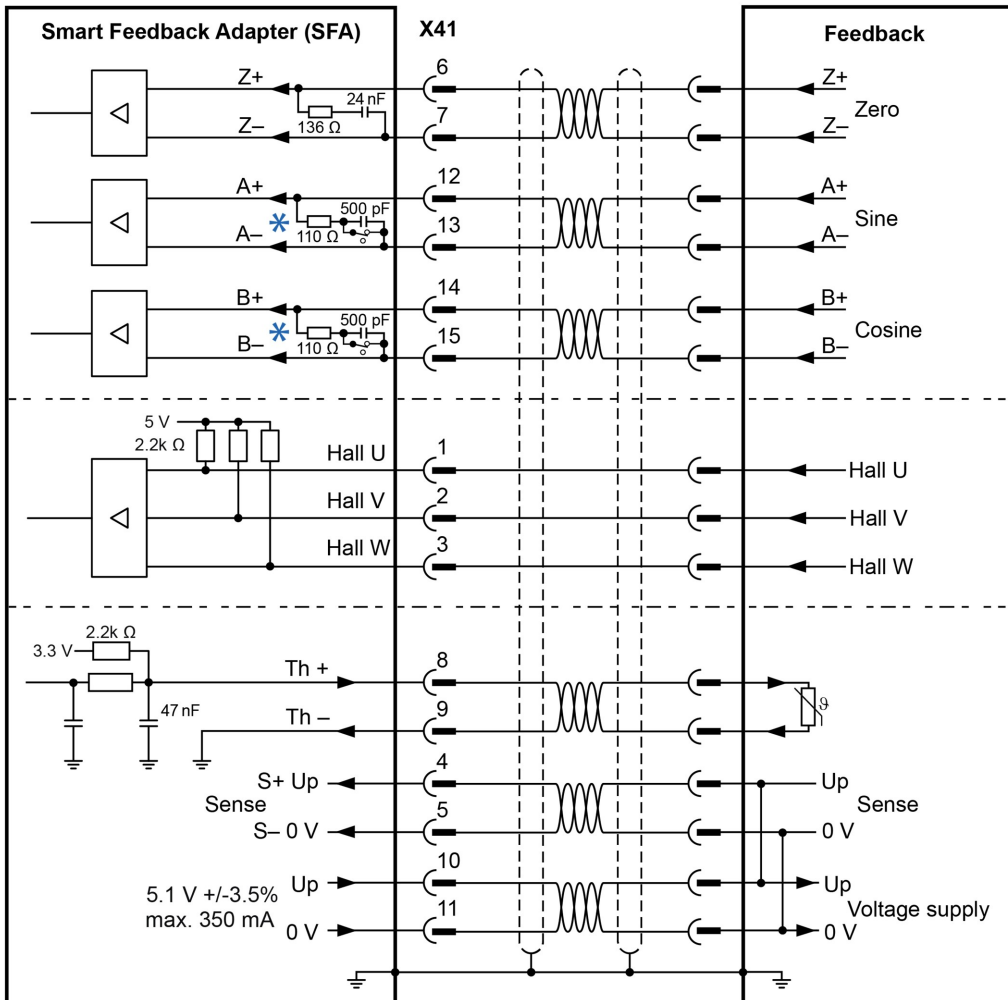

\* DC terminated by default - DC switch closed.

**8.10.12.12 X41 Hall Feedback**

This feedback type only supports operating in Torque mode and Velocity mode.

If cable lengths of more than 25m are planned, please consult customer support.

Type	FBx.INDENTIFIED	Up	Frequency Limit
Hall Only	112	5.1V ± 3.5%	1 MHz

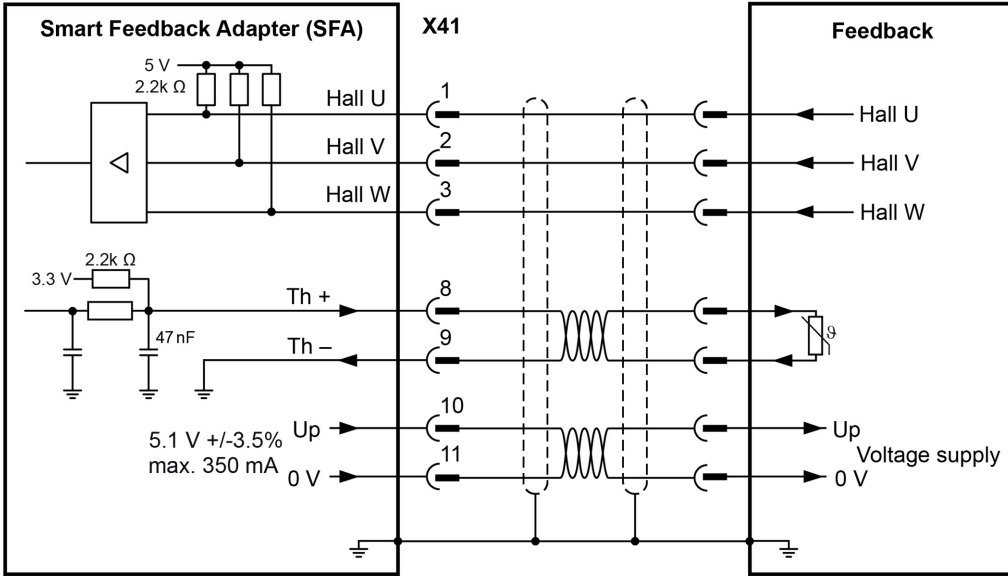

For more information concerning Hall feedback setting refer to WorkBench Online Help.

**8.10.12.13 X41 SSI Feedback**

Synchronous Serial Interface (SSI) is a standard industrial serial interface based on RS-422 standards.

If cable lengths of more than 25m are planned, please consult customer support.

Type	FBx.INDENTIFIED	Up	Frequency Limit
SSI (Synchronous Serial Interface)	136	5.1V ± 3.5%	1 MHz

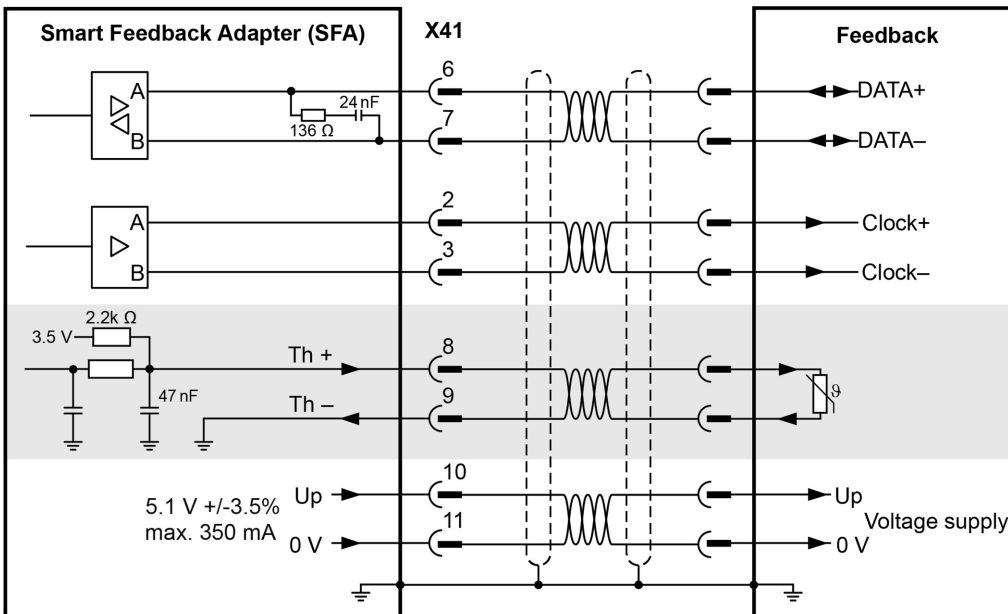

■ Optional



## 8.11 Gearing

### 8.11.1 Overview

#### Electronic Gearing, EEO, Master-Slave

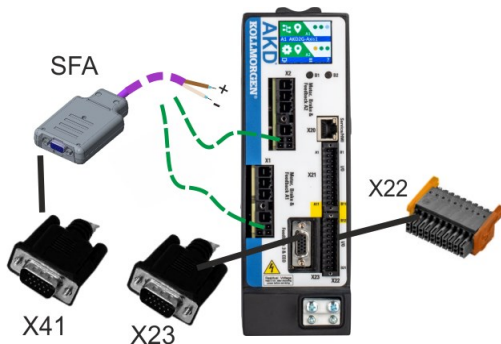

AKD2G offers up to 5 feedback channels, which may be used as the command source for electronic gearing or EEO (Emulated Encoder Output) or Master-Slave.

Feedback channel	EEO channel	Connector	Pinout and wiring example	Parameter to configure the sensor type
Feedback 1	N/A	X1	(→ # 106)	FB1.SELECT
		X41	(→ # 125)	
Feedback 2	N/A	X2	(→ # 106)	FB2.SELECT
		X5	(→ # 107)	
		X41	(→ # 125)	
Feedback 3	EEO1	X23	(→ # 110)	FB3.SELECT
Feedback 4	N/A	X21	(→ # 108)	FB4.SELECT
Feedback 5	EEO2	X22	(→ # 109)	FB5.SELECT

### 8.11.2 Input - Electronic Gearing

AKD2G offers up to 5 feedback channels. Any of these channels may be used as the gearing command source. The gearing source is selected for each axis using `AXIS#.GEAR.FBSOURCE`. Refer to the WorkBench Online Help [Electronic Gearing](#) for more information.

### 8.11.3 Output - Emulated Encoder Output (EEO)

The drive calculates the motor shaft position from the cyclic- absolute signals of the commutation feedback, generating incremental-encoder compatible pulses or CW/CCW signals or Pulse/Direction signals from this information.

The resolution and the index (zero) position can be set in WorkBench. The outputs are driven from an internal supply voltage. Refer to the WorkBench Online Help for more information.

#### NOTE

When using a multispeed resolver (more than 2 poles) as commutation feedback, the EEO will create only one zero pulse per each mechanical revolution of the motor. The zero pulse is dependent on the motor starting position!

#### NOTICE

EEO1-4 are NOT compatible with 24V signal level and will be damaged if connected to +24V!

#### Technical characteristics connector X22, EEO2

Pulse outputs on the connector X22 are 2 signals: track A and B with 90° phase difference (i. e. in quadrature, hence the alternative term “AquadB” output).

- RS-485, current 100 mA
- Max. number of connected slaves is determined by the loading characteristics of the slaves. 32 slaves can be driven if the input impedance of the bias network is 10kΩ and only one slave has a DC termination resistor.

- Max. signal (channel) output frequency: 3 MHz
- The pulses per revolution value is settable, pulse phase shift:  $90^{\circ} \pm 20^{\circ}$

X22	Signals EEO2	Description
A17	AGND	Analog ground
A20	Track A+	EEO2 output, channel A positive
A21	Track A-	EEO2 output, channel A negative
B20	Track B+	EEO2 output, channel B positive
B21	Track B-	EEO2 output, channel B negative

#### Technical characteristics connector X23, EEO1

Pulse outputs on the SubD connector X23 are 3 signals: A, B and Index with  $90^{\circ}$  phase difference (i.e. AquadB) and a zero pulse.

- 5V TTL, current 60 mA
- Max. number of connected slaves is determined by the loading characteristics of the slaves, 32 slaves can be driven if the input impedance of the bias network is 10k $\Omega$  and only one slave has a DC termination resistor.
- Max. signal (channel) output frequency: 3 MHz
- The pulses per revolution value is settable, pulse phase shift:  $90^{\circ} \pm 20^{\circ}$

X23	Signals EEO1	Description
6	Zero+	EEO1 output, index positive
7	Zero-	EEO1 output, index negative
11	0 V	EEO1 output, ground
12	Track A+	EEO1 output, channel A positive
13	Track A-	EEO1 output, channel A negative
14	Track B+	EEO1 output, channel B positive
15	Track B-	EEO1 output, channel B negative

#### Technical characteristics connector X41 (SFA), EEO3/EEO4

Pulse outputs on the SubD connector X41 are 3 signals: A, B and Index with  $90^{\circ}$  phase difference (i.e. "AquadB") and a zero pulse.

If SFA is connected to X1 the logical output is EEO3.

If SFA is connected to X2 or X5 the logical output is EEO4.

- 5V TTL, current 60 mA
- Max. number of connected slaves is determined by the loading characteristics of the slaves, 32 slaves can be driven if the input impedance of the bias network is 10k $\Omega$  and only one slave has a DC termination resistor.
- Max. signal (channel) output frequency: 3 MHz
- The pulses per revolution value is settable, pulse phase shift:  $90^{\circ} \pm 20^{\circ}$

X41	Signals EEO3/EEO4	Description
6	Zero+	EEO3/EEO4 output, index positive
7	Zero-	EEO3/EEO4 output, index negative
11	0 V	EEO3/EEO4 output, ground
12	Track A+	EEO3/EEO4 output, channel A positive
13	Track A-	EEO3/EEO4 output, channel A negative
14	Track B+	EEO3/EEO4 output, channel B positive
15	Track B-	EEO3/EEO4 output, channel B negative

### 8.11.4 Master-Slave control

Several AKD2G can be connected as slave drives to another AKD2G which acts as a master. The slave drives use the master's encoder output signal (EEO, (→ # 139)) as command input and follow these commands (velocity and direction).

#### 8.11.4.1 Examples

##### Master-Slave using feedback connector X22

The master is configured for EEO2 (→ # 139) on X22, the slave uses X22 for command input.

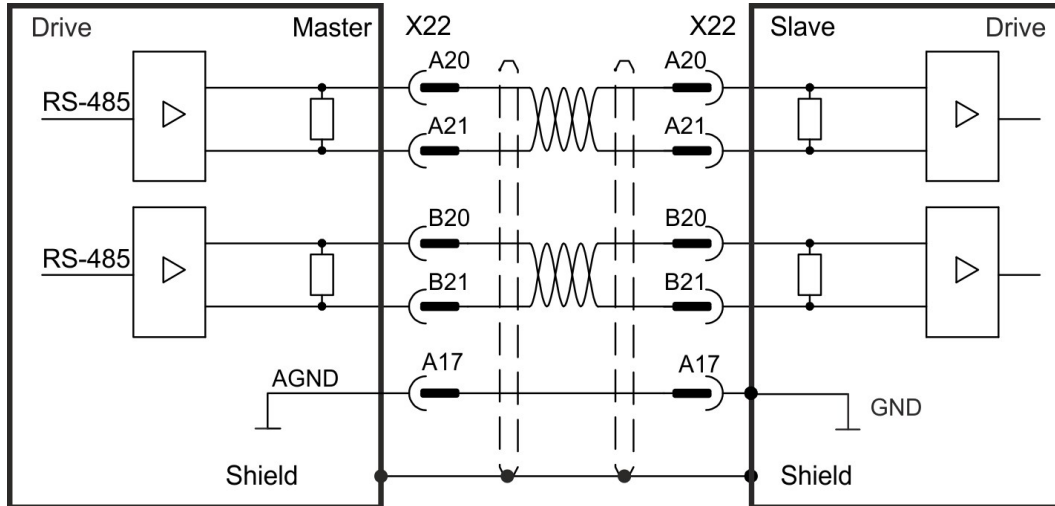

##### Master-Slave using optional feedback connector X23 or X41

The master is configured for EEO1 (→ # 140) on X23 or EEO3/EEO4 ((→ # 139) with SFA) on X41, the slave uses X23 (or X41 with SFA) for command input.

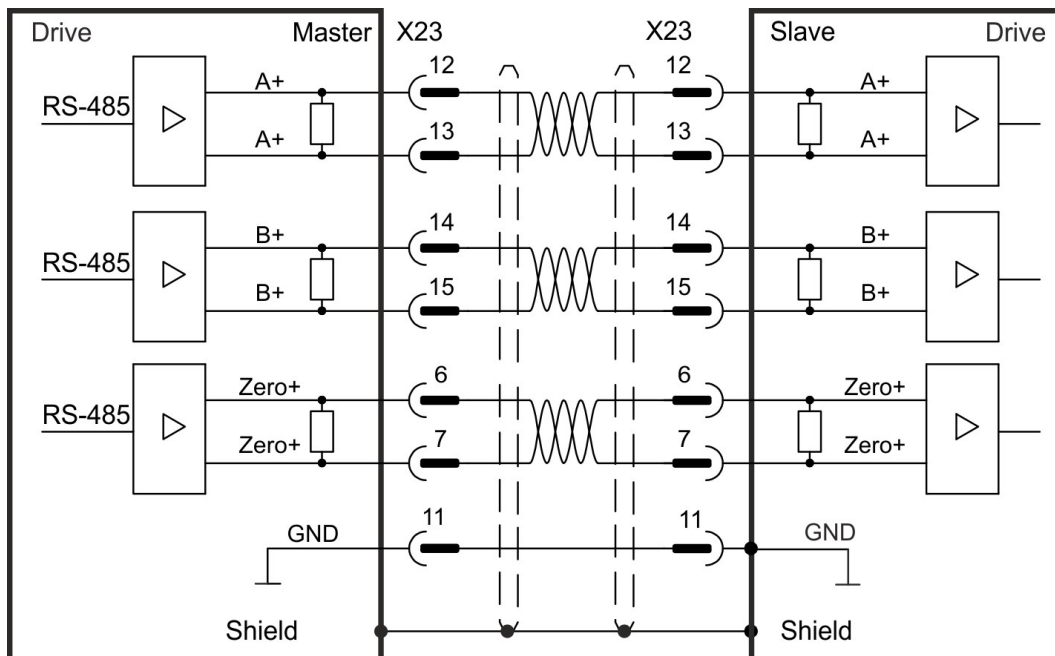

### 8.12 Ethernet Fieldbus Interface Connector X11/X12

The Ethernet fieldbus interface has two RJ45 connectors.

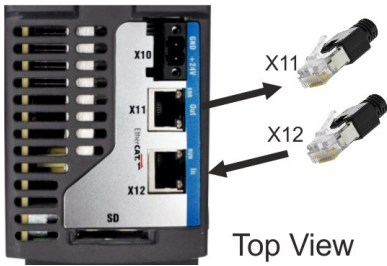

- RJ45 with built-in green/red dual-color LED
- EtherCAT®
- EtherNet/IP®
- PROFINET®

**NOTICE**

Do not connect the Service line for the PC with the set up software to the Ethernet fieldbus interface X11/X12. The service Ethernet cable must be connected to X20.

Ethernet fieldbus interface X11/X12 pinout depends on the used protocol. Refer to the matching fieldbus communication manual.

#### 8.12.1 EtherCAT®

AKD2G drives (connectivity option **E**) can be connected as slaves to the EtherCAT® network (CoE) by using RJ45 connectors X11 (out port) and X12 (in port). The communication status is indicated by the built-in connector LEDs.

	Connector	Name	Function
	X11 "Out"	"ERR"	Returns potentials communication failures: Off = No Error Blinking = Invalid configuration Single Flash = Local error Double Flash = Process data watchdog
	X11 "Out"	Link/Activity	On/Blinking: Physical link/Data Traffic on. Static off: No link.
	X12 "In"	"RUN"	Returns the device state: Off = INIT Blinking = PRE-OPERATIONAL Single Flash = SAFE-OPERATIONAL On = OPERATIONAL Flickering = Initialization or BOOTSTRAP
	X12 "In"	Link/Activity	On/Blinking: Physical link/Data Traffic on. Static off: No link.

#### Bus topology example (EtherCAT®)

We suggest to use Kollmorgen ENCP cables. For more possible system solutions refer to the WorkBench Online Help.

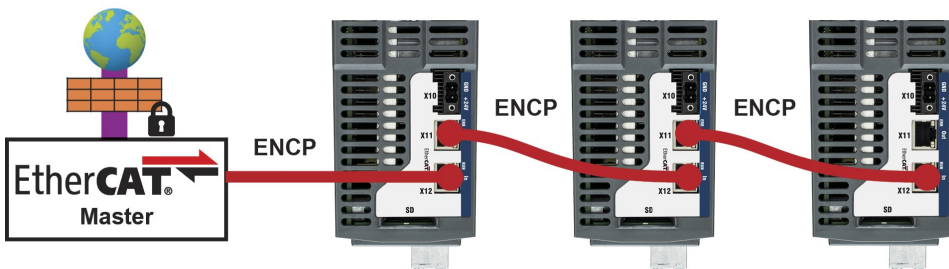

#### Communication profile

For EtherCAT® communication profile description refer to the manual "AKD2G EtherCAT® Communication".

### 8.12.2 PROFINET

AKD2G with connectivity option **P** can be connected as slaves to a PROFINET network by using RJ45 connectors X11 (Port 2) and X12 (Port 1). PROFINET RT or IRT protocols can be used.



AKD2G with connectivity option **P** (PROFINET) has successfully passed the certification tests of "PROFIBUS Nutzerorganisation e.V."

Scope of the tests:

- PNIO Version: V2.35
- Conformance Class: C
- Optional Features: Legacy, MRP
- Application Class: Isochronous
- Netload Class: III

The certificate ([Z12974](#)) can be downloaded from the Kollmorgen website.

#### Address

The field bus address must either be set automatically or by using the memory card.

#### LEDs

The communication status is indicated by the built-in connector LEDs.

	Connector	Name	Function
	X11 Port 2	BF	ON = No Configuration, low speed, no link OFF = No Error Flashing 2Hz = No data exchange
	X11 Port 2	Link/Activity	ON = Connection to the EtherNet OFF = No connection to the EtherNet Flashing = Sends/receives EtherNet frames
	X12 Port 1	SF	ON = Watchdog timeout; channel / generic / extended diagnosis present; system error OFF = No Error Flashing 2Hz = DCP signal service is initiated via the bus
	X12 Port 1	Link/Activity	ON = Connection to the EtherNet OFF = No connection to the EtherNet Flashing = Sends/receives EtherNet frames

#### Bus topology example (PROFINET)

Kollmorgen suggest to use ENCP cables. For more possible system solutions refer to the WorkBench Online Help.

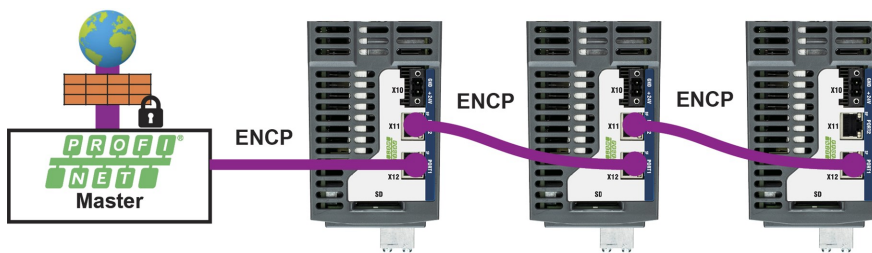

#### Communication profile

For PROFINET communication profile description refer to the manual "AKD2G PROFINET Communication".

### 8.12.3 EtherNet/IP

AKD2G with connectivity option I can be connected as slaves to a EtherNet/IP network by using RJ45 connectors X11 (Port 2) and X12 (Port 1). The communication status is indicated by the built-in connector LEDs.

Connector	Name	LED Indicator	Status	Function
	Network Status (NS)		On	Connection
			Flashing	No Connection
			Off	No power, No IP Address
			On	Duplicate IP Address
			Flashing	Connection Time-Out
			Flashing	Self-Test
	Link/Activity		On	Ethernet Connection
			Off	No Ethernet Connection
	Module Status (MS)		On	Device Operational
			Flashing	Standby
			Off	No Power
			On	Unclearable Fault
		Flashing	Clearable Fault	
		Flashing	Self-Test	
Link/Activity		On	Ethernet Connection	
		Off	No Ethernet Connection	

#### Bus topology example (EtherNet/IP)

We suggest to use Kollmorgen ENCP cables. For more possible system solutions refer to the WorkBench Online Help.

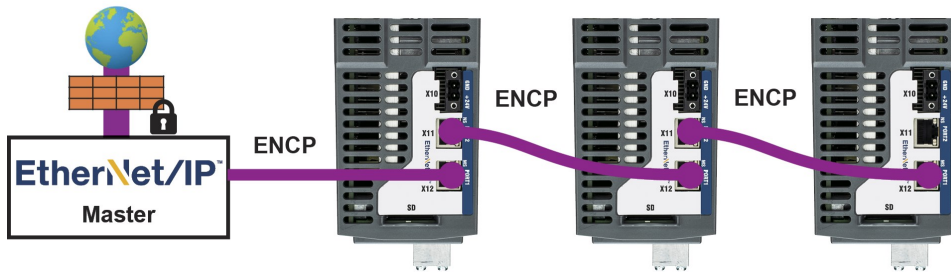

#### Communication profile

For EtherNet/IP communication profile description refer to the manual "AKD2G EtherNet/IP Communication".

### 8.13 CAN-Bus Interface connector X13/X14

AKD2G drives with connectivity option **C** can be connected to a CAN-Bus by using two 6-pin RJ25 connectors X13/X14.

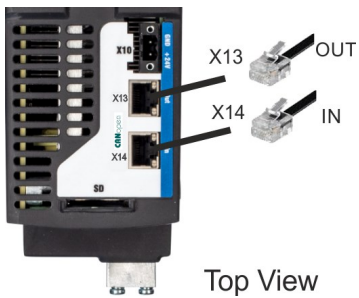

- RJ25
- Up to 1000 kbit/s operation
- Node ID to be set by WorkBench
- Baudrate to be set by WorkBench

Pin	Signal	Description
1	Termination	Internal Termination Resistor
2	Shield	Chassis
3	CAN_high	CAN bus high signal
4	CAN_low	CAN bus low signal
5	CAN_GND	CAN bus ground
6	Termination	Internal Termination Resistor

#### 8.13.1 CAN-Bus Topology

We recommend the use of Kollmorgen CBP000 cables.

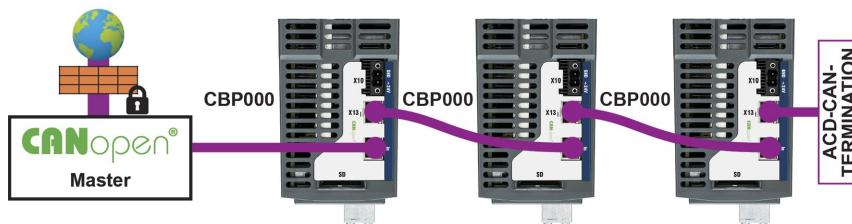

#### Cable requirements

To meet ISO 11898, a bus cable with a characteristic impedance of 120  $\Omega$  should be used. The maximum usable cable length for reliable communication decreases with increasing transmission speed.

As a guide, you can use the following values measured by Kollmorgen; however, these values are not assured limits:

- Characteristic impedance: 100–120  $\Omega$
- Cable capacitance max.: 60 nF / 1000 m
- Lead loop resistance: 159.8  $\Omega$  / 1000 m

Transmission Rate (kBaud)	1000	500	250	125
Maximum Cable Length (m)	25	100	250	500

Lower cable capacitance (max. 30 nF / 1000 m) and lower lead resistance (loop resistance, 115  $\Omega$  / 1000 m) allow larger distances. The characteristic impedance 150  $\pm$  5  $\Omega$  requires terminating resistor 150  $\pm$  5  $\Omega$ .

#### Communication profile

For CANopen communication profile description refer to the manual "AKD2G CAN-Bus Communication".



### 8.13.2 CAN-Bus Wiring

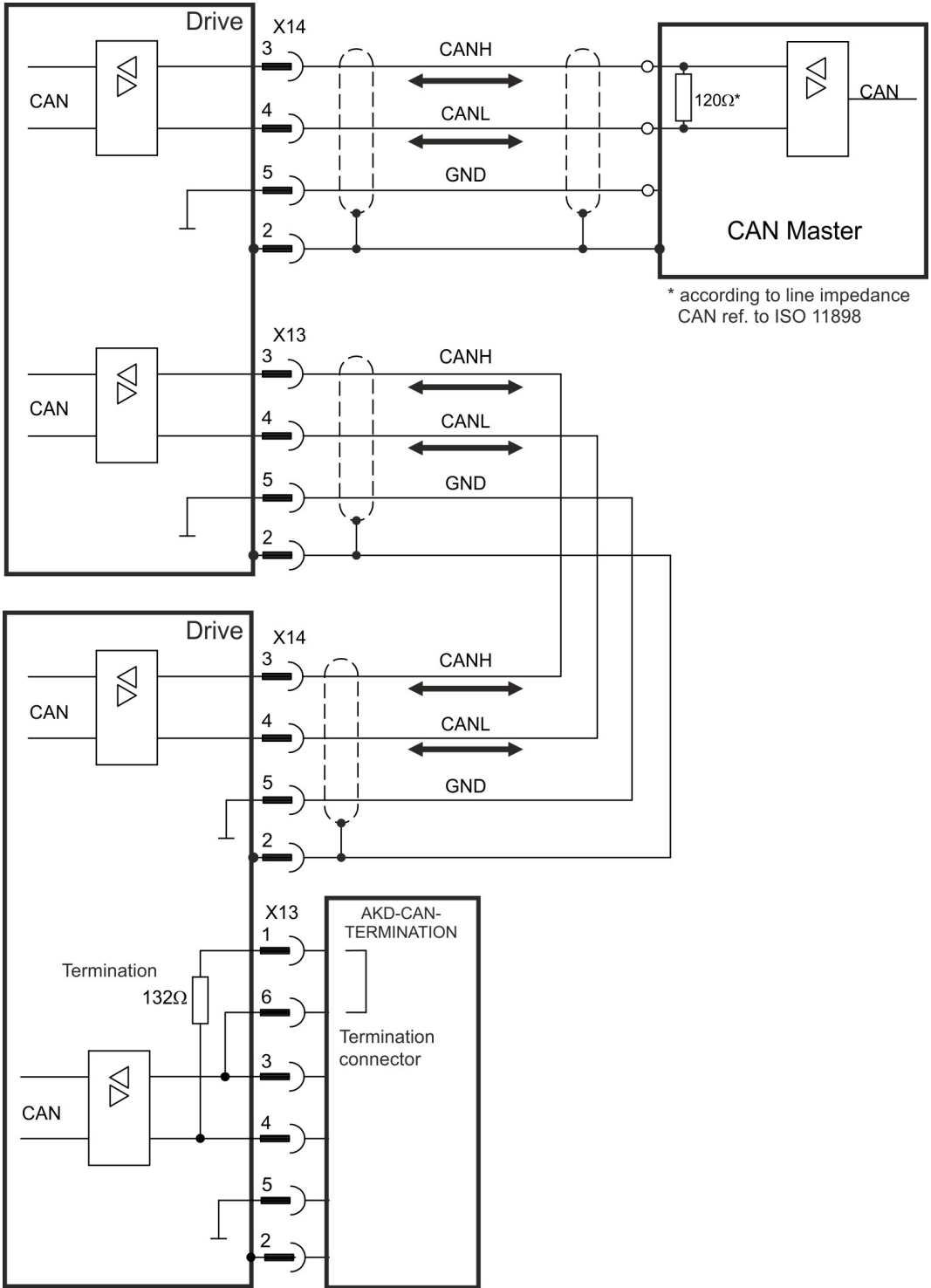



### 8.13.3 Baud rate for CAN-Bus

The transmission rate can be set by using the parameter **CANBUS.BAUD** in WorkBench.

Baud rate [kBit/s]	CANBUS.BAUD
125	125 (default)
250	250
500	500
1000	1000

With a fix baud rate, the drive sends the boot up message with the baud rate saved in the drive's non volatile memory after a power cycle.

### 8.13.4 Node Address for CAN-Bus

The node address can be set by using parameter **CANBUS.NODEID** in WorkBench.

#### NOTE

After changing the node address, you must turn off the 24 V auxiliary supply for the drive and then turn it on again.

### 8.13.5 CAN-Bus Termination

The last bus device on both ends of the CAN-Bus system must have termination resistors. The AKD2G has built-in 132  $\Omega$  resistors that can be activated by connecting pins 1 and 6. An optional termination plug is available for AKD2G (*AKD-CAN-TERMINATION*). The optional termination plug is an RJ25 connector with an enclosed wire jumper between pins 1&6. The termination plug should be inserted into the X13 connector of the last drive in the CAN network.

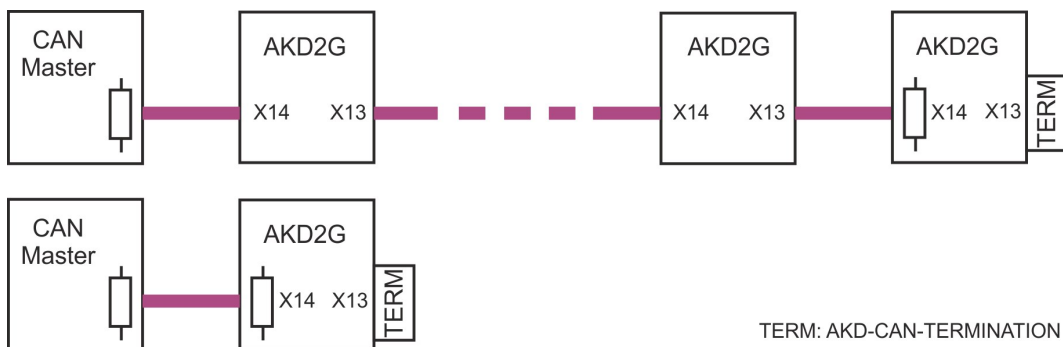

#### NOTE

Remove the termination connector if the AKD2G is not the last CAN-Bus device and use X13 for connecting the next CAN node.

### 8.14 Service Interface connector X20



- RJ45 with built-in green/red dual-color LED
- 100/10 Mbit EtherNet TCP/IP
- Supports Auto-IP, DHCP and fixed IP addressing
- Supports point-to-point (i.e. Auto-IP) and connection by using network switches
- Supports automatic discovery in WorkBench if in the same sub-net.

Pin	Signal	Description
1	Tx+	Transmit +
2	Tx-	Transmit -
3	Rx+	Receive +
4	Termination	Bob Smith termination
5	Termination	Bob Smith termination
6	Rx-	Receive -
7	Termination	Bob Smith termination
8	Termination	Bob Smith termination

Operating, position control and motion-block parameters can be set up by using WorkBench on an ordinary commercial PC (→ # 168).

Connect the service interface X20 of the drive to an EtherNet interface on the PC directly or by using a network switch, **while the supply to the equipment is switched off**. Use standard Cat. 5 EtherNet cables for connection. In some cases crossover cables will also work.

Make sure that the link LED on the AKD2G (RJ45 connector) and on your PC (or network switch) are both illuminated. The electrical connection is well established if both LED's light up green.

#### 8.14.1 Possible Network Configurations

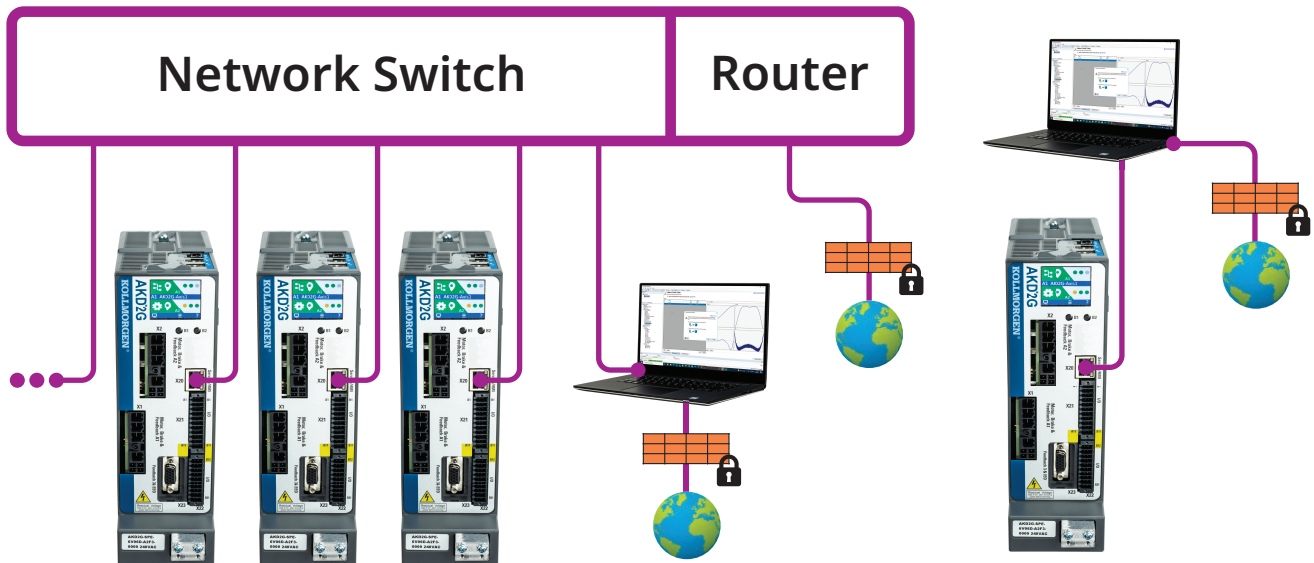

## 8.15 Modbus TCP connector X20

The drive can be connected to Modbus HMI by using RJ45 connector X20. The protocol allows reading and writing of drive and axis parameters.

The communication status is indicated by the built-in LED.

Connector	LED	Name	Function
X20	LED	IN port Link	green = active, red= not active

Connect the service interface (X20) of the drive to an EtherNet interface on the Modbus HMI directly or by using a network switch, **while the supply to the equipment is switched off**. Use standard Cat. 5 EtherNet cables for connection.

Confirm that the link LED on the AKD2G (the green LED on the RJ45 connector) and on your HMI or switch are both illuminated. If both LEDs are illuminated, then you have a good electrical connection.

The following are required to connect an HMI to the drive:

- The HMI must support Modbus TCP.
- It must have EtherNet hardware and a driver for Modbus TCP, though the driver does not have to be made specifically for the AKD2G family.

The subnet mask of the AKD2G is 255.255.255.0. The first three octets of the drive's IP address must be the same as the first three octets of the HMI's IP address. The last octet must be different.

Modbus TCP and WorkBench/KAS IDE can operate simultaneously if a switch is used.

### Communication profile

For Modbus communication profile description refer to the WorkBench Online Help.

### 8.16 I/O Connectors X21/X22/X23

#### X21

- standard
- 2 x 11 pins, pitch 3.5 mm
- A: left connector
- B: right connector

#### X22

- standard for dual-axis drives
- optional for single axis drives
- 2 x 10 pins, pitch 3.5 mm
- A: left connector
- B: right connector

#### X23

- optional
- SubD 15 pins HD
- Mating connector: male

X21	Pin	Signal	Pin	Signal
	A1	Analog-In (AIN) 1 +	B1	Analog-Out (AOUT) 1
	A2	Analog-In (AIN) 1 -	B2	AGND
	A3*	Digital-In (DIN) 1	B3	+24 V
	A4*	Digital-In (DIN) 2	B4	DGND
	A5	Digital-In (DIN) 3 (HW-Enable Axis 1)	B5	Digital-Out (DOU) 9 + (Relay)
	A6	Digital-In (DIN) 4 (HW-Enable Axis 2)	B6	Digital-Out (DOU) 9 - (Relay)
	A7	Digital-In (DIN) 5	B7	Digital-Out (DOU) 1
	A8	Digital-In (DIN) 6	B8	Digital-Out (DOU) 2
	A9	Digital-In (DIN) 7	B9	Digital-Out (DOU) 3
	A10	Digital-In (DIN) 8	B10	Digital-Out (DOU) 4
	A11	STO-A-A1	B11	STO-B-A1

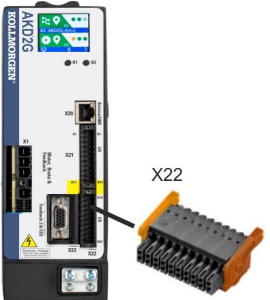
X22*	Pin	Signal	Pin	Signal
	A12	STO-A-A2, dual-axis	B12	STO-B-A2, dual-axis
	A13	Digital-In (DIN) 9	B13	Digital-Out (DOU) 5
	A14	Digital-In (DIN) 10	B14	Digital-Out (DOU) 6
	A15	Digital-In (DIN) 11	B15	Digital-Out (DOU) 7 +
	A16	Digital-In (DIN) 12	B16	Digital-Out (DOU) 7 -
	A17	AGND	B17	Digital-Out (DOU) 8 +
	A18	Analog-In (AIN) 2+	B18	Digital-Out (DOU) 8 -
	A19	Analog-In (AIN) 2-	B19	Analog-Out (AOUT) 2
	A20*	Digital-In/Out (DIO) 1 +	B20*	Digital-In/Out (DIO) 2 +
	A21*	Digital-In/Out (DIO) 1 -	B21*	Digital-In/Out (DIO) 2 -

\*(optional for single axis drives, standard for dual-axis drives)

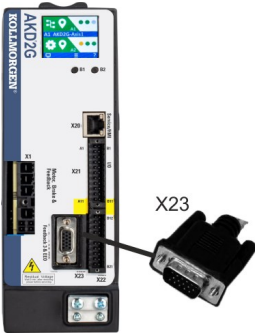
X23 (optional)	Pin	Signal
	2	Digital-In/Out (DIO) 6 +
	3	Digital-In/Out (DIO) 6 -
	6	Digital-In/Out (DIO) 5 +
	7	Digital-In/Out (DIO) 5 -
	10	+5 V
	11	0 V
	12	Digital-In/Out (DIO) 3 +
	13	Digital-In/Out (DIO) 3 -
	14	Digital-In/Out (DIO) 4 +
15	Digital-In/Out (DIO) 4 -	

## 8.16.1 Technical data

Interface	Electrical Data
Analog inputs Analog-In (AIN) 1 to 2	<ul style="list-style-type: none"> <li>• <math>\pm 10</math> VDC</li> <li>• common mode rejection ratio: &gt; 30 dB at 60 Hz</li> <li>• resolution 16 bit and full monotonic</li> <li>• update rate: 16 kHz</li> <li>• non-linearity &lt; 0.1% of full scale</li> <li>• offset drift max. 250 <math>\mu\text{V}/^\circ\text{C}</math></li> <li>• input impedance &gt; 13 k<math>\Omega</math></li> </ul>
Analog outputs Analog-Out (AOUT) 1 to 2	<ul style="list-style-type: none"> <li>• 0 to +10 VDC, max 20 mA</li> <li>• resolution 16 bit and full monotonic</li> <li>• update rate: 4 kHz</li> <li>• non-linearity &lt; 0.1% of full scale</li> <li>• offset drift max. 250 <math>\mu\text{V}/^\circ\text{C}</math></li> <li>• short circuit protected to AGND</li> <li>• output impedance 110 <math>\Omega</math></li> </ul>
Digital inputs Digital-In (DIN) 1 to 2 IEC 61131-2 Type 1	<ul style="list-style-type: none"> <li>• ON: 15 VDC to 30 VDC, 2 mA to 15 mA</li> <li>• OFF: -5 VDC to 5 VDC, max. 15 mA</li> <li>• galvanic isolation for 60 VDC</li> <li>• activation / deactivation delay: &lt; 1 <math>\mu\text{s}</math> / &lt; 1 <math>\mu\text{s}</math></li> </ul>
Digital inputs Digital-In (DIN) 3 to 12 IEC 61131-2 Type 1	<ul style="list-style-type: none"> <li>• ON: 15 VDC to 30 VDC, 2 mA to 15 mA</li> <li>• OFF: -5 VDC to 5 VDC, max. 15 mA</li> <li>• galvanic isolation for 60 VDC</li> <li>• delay activation / deactivation: about 5 <math>\mu\text{s}</math> / 500 <math>\mu\text{s}</math></li> </ul>
Digital outputs Digital-Out (DOUT) 1 to 6	<ul style="list-style-type: none"> <li>• max. 30 VDC, 100 mA</li> <li>• short circuit proof</li> <li>• galvanic isolation for 60 VDC</li> <li>• delay activation / deactivation: about 5 <math>\mu\text{s}</math> / 300 <math>\mu\text{s}</math></li> </ul>
Digital outputs Digital-Out (DOUT) 7 to 8	<ul style="list-style-type: none"> <li>• volt-free contacts, max 30 VDC, 100 mA</li> <li>• sink or source</li> <li>• galvanic isolation for 24 VDC from PE</li> <li>• delay activation / deactivation: about 5 <math>\mu\text{s}</math> / 50 <math>\mu\text{s}</math></li> </ul>
Digital inputs/outputs Digital-In/Out (DIO) 1 to 6	<ul style="list-style-type: none"> <li>• RS485, 5V, max 100mA</li> <li>• reference potential X22: AGND, X23: 0V</li> <li>• input OFF: -0.3 V to +0.3 V</li> <li>• selectable termination, difference/single ended</li> <li>• delay activation / deactivation: about 50 ns</li> </ul>
Digital output Digital-Out (DOUT) 9	<ul style="list-style-type: none"> <li>• max. 30 VDC, 1A</li> <li>• max. 42 VAC, 1 A</li> <li>• galvanic isolation for 24 VDC from PE</li> <li>• delay open/close: 10 ms / 10 ms</li> </ul>
Safe digital inputs Axis 1: STO-A-A1, STO-B-A1 Axis 2: STO-A-A2, STO-B-A2	<ul style="list-style-type: none"> <li>• ON: 17 VDC to 30 VDC, 5 mA to 6 mA</li> <li>• OFF: 0 VDC to 5 VDC, max. 1 mA</li> <li>• galvanic isolation for 60 VDC</li> <li>• delay activation / deactivation about: 1.5 ms / 3.5 ms</li> </ul>

### 8.16.2 Analog Input

The drive is fitted with differential inputs for analog torque, velocity, or position control. The standard drive offers one analog input on X21, dual axis drives and drives with built-in option IO or DX offer a second analog input on X22.

**NOTICE** Maximum distance for unshielded I/O lines is 3 m inside the cabinet. If the I/O cable leaves the cabinet, it must be EMC shielded.

#### Technical characteristics

- Differential input voltage range:  $\pm 10$  V
- Maximum input voltage referring to I/O Return: -12.5, +16.0 V
- Resolution: 16 Bit and fully monotonic
- Firmware update rate: 16 kHz
- Unadjusted offset: < 50 mV
- Offset drift typ:  $250 \mu\text{V} / ^\circ\text{C}$
- Gain or slope tolerance:  $\pm 3\%$
- Nonlinearity: < 0.1% of full scale or 12.5 mV
- Common Mode Rejection Ratio: > 30 dB at 60 Hz
- Input impedance: > 13k  $\Omega$ s
- Signal to noise ratio referred to full scale:
  - AIN.CUTOFF = 3000 Hz: 14 bit
  - AIN.CUTOFF = 800 Hz: 16 bit

#### Analog Input Wiring Diagram

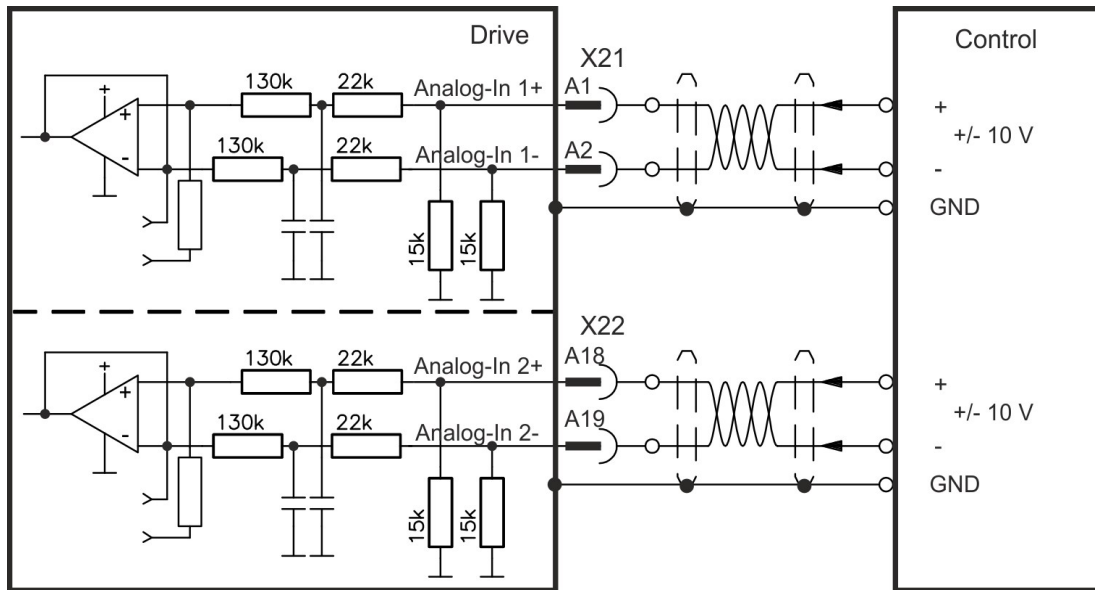

#### Application examples for set point input Analog-In:

- reduced-sensitivity input for setting-up/jog operation
- pre-control/override

#### Defining the direction of rotation

Standard setting: clockwise rotation of the motor shaft (looking at the shaft end) affected by positive voltage between terminal (+) and terminal (-)

To reverse the direction of rotation, swap the connections to terminals +/- or change parameter AXIS#.DIR in WorkBench.

### 8.16.3 Analog Output

Analog Outputs can be used to output converted analog values of digital measurements recorded in the drive. The standard drive offers one analog output on X21, dual axis drives and drives with built-in option IO or DX offer a second analog output on X22.

#### NOTICE

Maximum distance for unshielded I/O lines is 3 m inside the cabinet. If the I/O cable leaves the cabinet, it must be EMC shielded.

#### Technical characteristics

- Output voltage range referring to AGND: 0 to 10 V
- Resolution: 16 Bit and fully monotonic
- Update rate: 4 kHz
- Unadjusted offset: < 50 mV
- Offset drift typ: 250  $\mu\text{V}/^\circ\text{C}$
- Gain or slope tolerance: +/- 3%
- Nonlinearity: < 0.1% of full scale or 20 mV
- Output impedance: 110  $\Omega$
- Specification complies with IEC 61131-2 Table 11
- -3 dB Bandwidth: >8 kHz
- Maximum output current: 20 mA
- Capacitive load: any value but response speed limited by max lout and by Rout
- Protected for short circuit to AGND

#### Analog Output Wiring Diagram

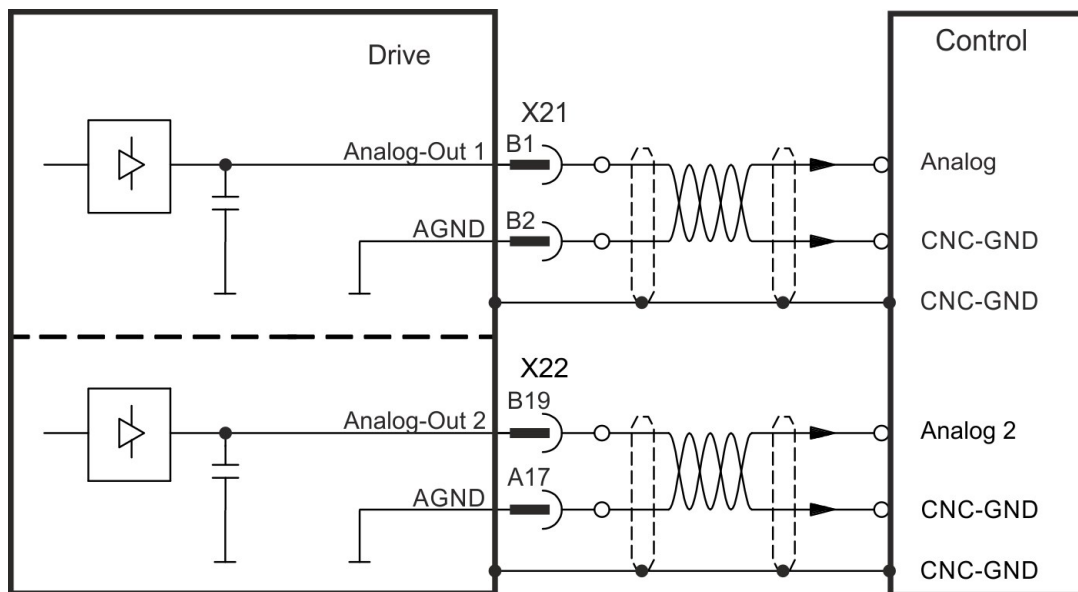

### 8.16.4 Digital Inputs

The drive provides 8 digital inputs on X21. Dual axis drives and drives with built-in option IO or DX offer additional 4 inputs on X22 and 2 programmable Input/Outputs on X22. If X23 is built-in and not used for feedback or EEO function, then it offers 4 additional programmable Input/Outputs.

All inputs can be used to initiate pre-programmed actions. A list of actions is included in WorkBench. If an input is programmed, it must be saved to the drive.

The drive provides 4 safe digital inputs on X21 and X22. These inputs can be used as safe inputs, based on the installed functional option (→ # 184).

**NOTICE** Maximum distance for unshielded I/O lines is 3 m inside the cabinet. If the I/O cable leaves the cabinet, it must be EMC shielded.

**NOTE** Depending on the selected function, the inputs are high or low active. Digital input filter can be set in WorkBench to change sensitivity of the inputs (see Online Help).

#### 8.16.4.1 Digital-In 1 and 2

These inputs (IEC 61131-2 Type 1) are particularly fast and are therefore suitable for position latch functions. They can also be used as 24 V inputs for electronic gearing (→ # 139).

#### Technical characteristics

- Floating, reference common line is DGND
- High: 15 to 30 V/2 to 15 mA , Low: -5 to +5 V/<15 mA
- Update rate: firmware reads hardware input state every 250 μs
- High accuracy latch: motor feedback position or interpolated time is latched or captured within 2 μs of input signal transition (with digital input filter set to 40 ns)
- The AKD2G capture engine is polled every 62.5 μs (16 kHz) by the firmware

#### Wiring example

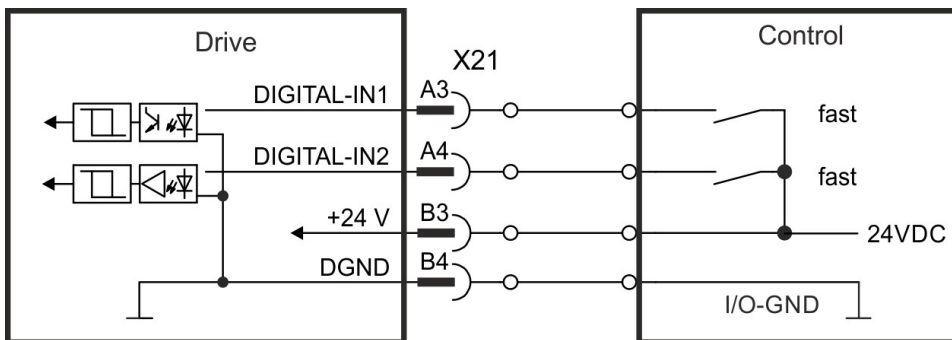



### 8.16.4.2 Digital-In 3 to 12

These inputs (IEC 61131-2 Type 1) are programmable with WorkBench.

#### Manufacturer setting:

- Digital-In 3: HW-Enable Axis 1
- Digital-In 4: HW-Enable Axis 2
- Digital-In 5 ... 12: off

Choose the function you require in WorkBench and refer to the software for more information.

#### Technical characteristics

- Floating, reference common line is DGND
- High: 15 to 30 V/2 to 15 mA , Low: -5 to +5 V/<15 mA
- Update rate: firmware reads hardware input state every 250  $\mu$ s

#### Wiring example

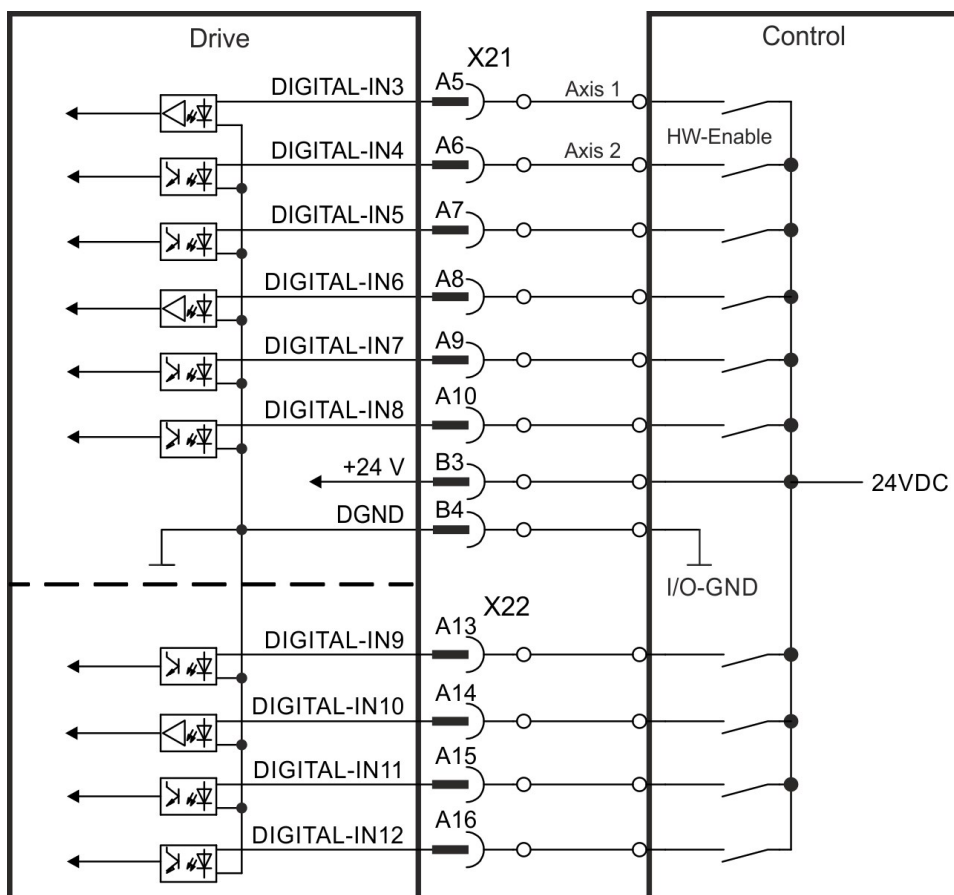

### 8.16.4.3 Digital-In/Out 1 and 2

Pins X22/A20-A21 (Digital-In/Out 1) and X22/B20-B21 (Digital-In/Out 2) can be defined as either inputs or outputs. For programming refer to WorkBench.

**NOTICE** NOT compatible with 24V signal level! Will be damaged if connected to +24V!

#### Technical characteristics if configured as input

- RS485, reference common line is AGND
- No wire break detection
- Digital IN/OUT 1/2: Selectable DC termination for differential or single ended input
- Update rate: firmware reads hardware input state every 250  $\mu$ s

#### Wiring example

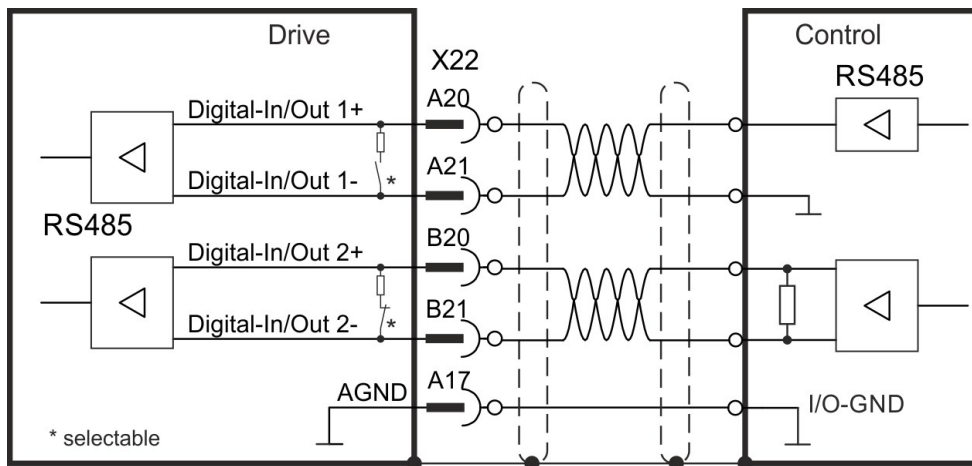

### 8.16.4.4 Digital-In/Out 3 to 6

X23 can be used for digital I/O. The channels can be defined as inputs or outputs. For programming refer to WorkBench.

#### NOTICE

NOT compatible with 24 V signal level! Will be damaged if connected to +24 V!

#### Technical characteristics if configured as input

- RS485, reference common line is 0 V
- No wire break detection
- Digital IN/OUT 3/4: Selectable DC termination for differential or single ended input
- Digital IN/OUT 5/6: AC termination for single ended input
- Update rate: firmware reads hardware input state every 250  $\mu$ s

#### Wiring example

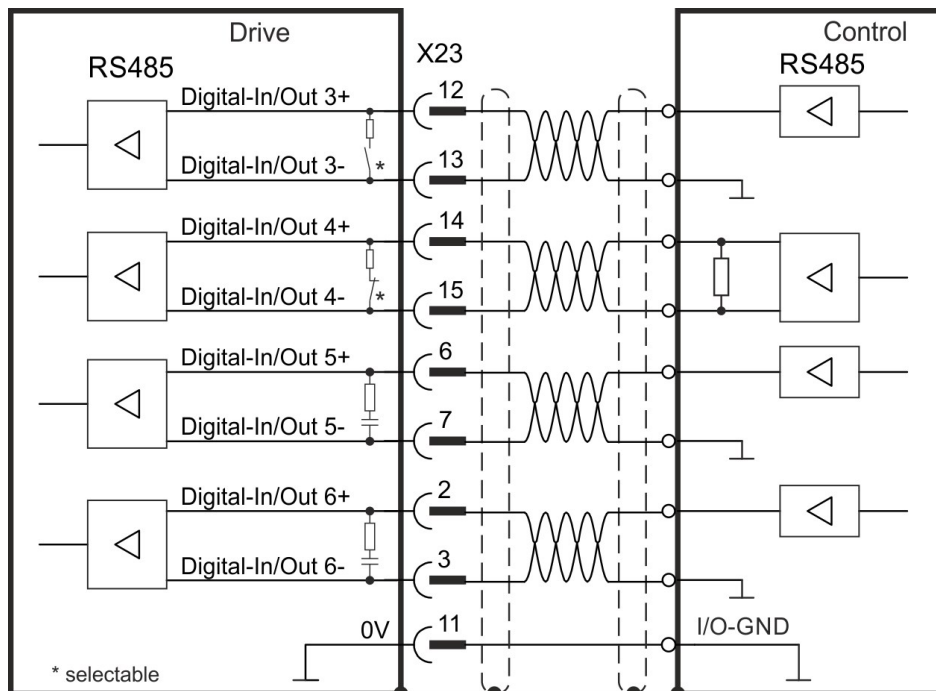

### 8.16.5 Digital Outputs

The drive provides 4 digital outputs on X21. For more information refer to WorkBench.

Dual axis drives and drives with built-in option IO or DX offer additional 4 digital outputs and 2 programmable Input/Outputs. If X23 is built-in and not used for feedback or EEO function, then it offers 4 additional programmable Input/Outputs.

The relay output can be used as fault or ready to operate signal.

**NOTICE** Maximum distance for unshielded I/O lines is 3 m inside the cabinet. If the I/O cable leaves the cabinet, it must be EMC shielded.

Choose the required action in WorkBench. A list of actions is included in the software. If an output is programmed, it must be saved to the drive.

#### 8.16.5.1 Digital-Out 1 to 6

These outputs are programmable with WorkBench. By default, all outputs are not programmed (off).

#### Technical characteristics

- The outputs can switch +5 V to +30 V
- All digital outputs are floating
- High side, output current max. 100 mA
- Update rate: 250  $\mu$ s

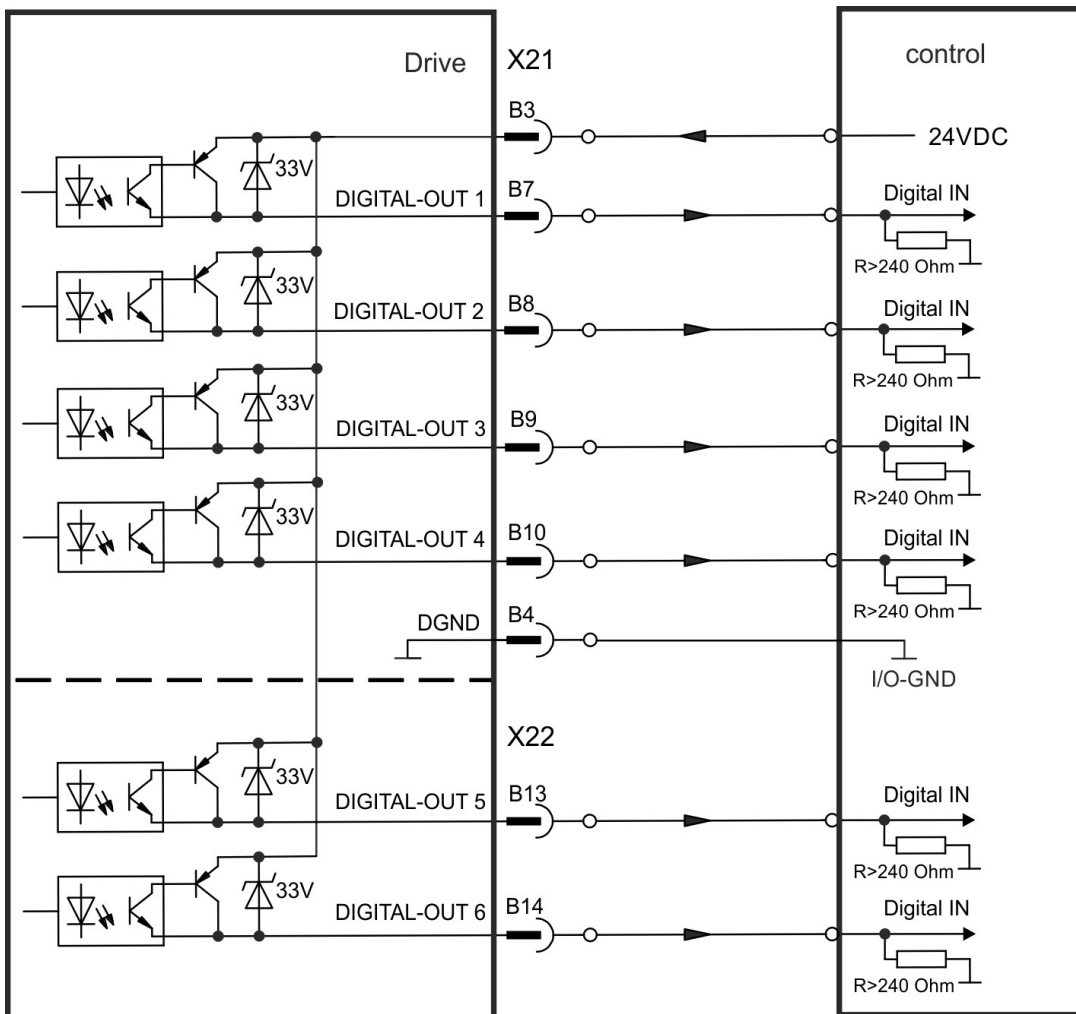

### 8.16.5.2 Digital-Out 7 and 8

These outputs are programmable with WorkBench. By default, all outputs are not programmed (off).

#### Technical characteristics

- The outputs can switch +5 V to +30 V
- Galvanic isolation for 24 VDC from PE
- The two channels are isolated from one another and not referred to a common potential
- Output current max. 100 mA
- Can be wired as sinking or sourcing (see examples below)
- Update rate: 250  $\mu$ s

#### Wiring examples

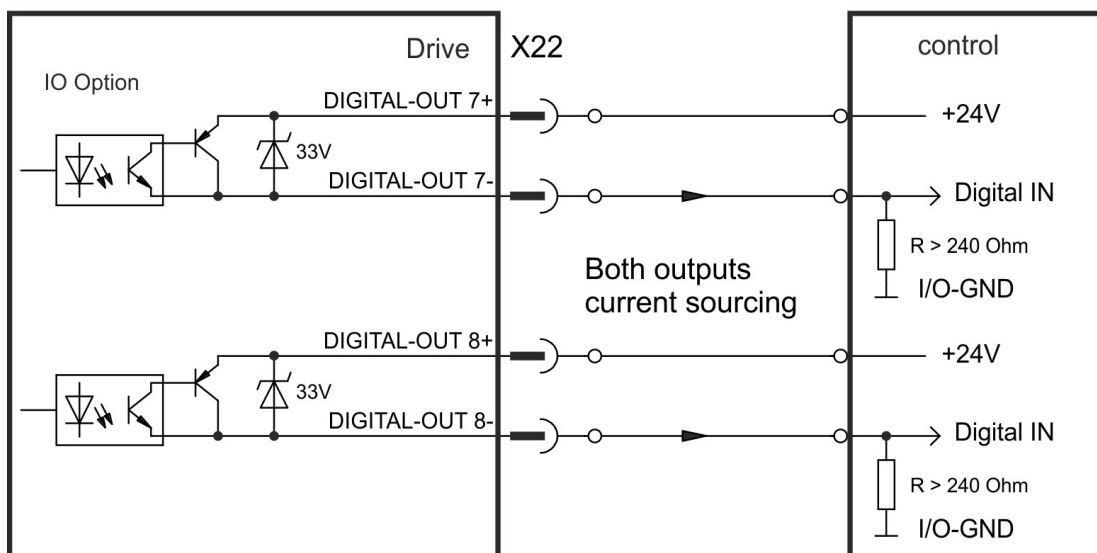
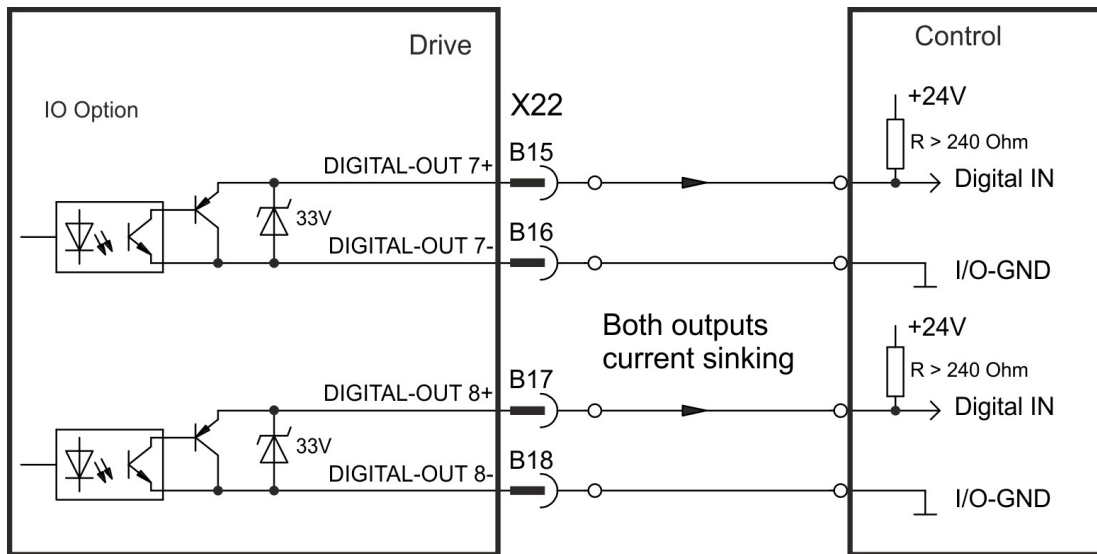

### 8.16.5.3 Digital-In/Out 1 and 2

Pins X22/A20-A21 (Digital-In/Out 1) and X22/B20-B21 (Digital-In/Out 2) can be used as either inputs or outputs. For programming refer to WorkBench.

#### Technical characteristics if configured as output

- RS485, reference common line is AGND
- Selectable DC termination for differential or single ended output, no wire break detection
- Update rate: 250  $\mu$ s

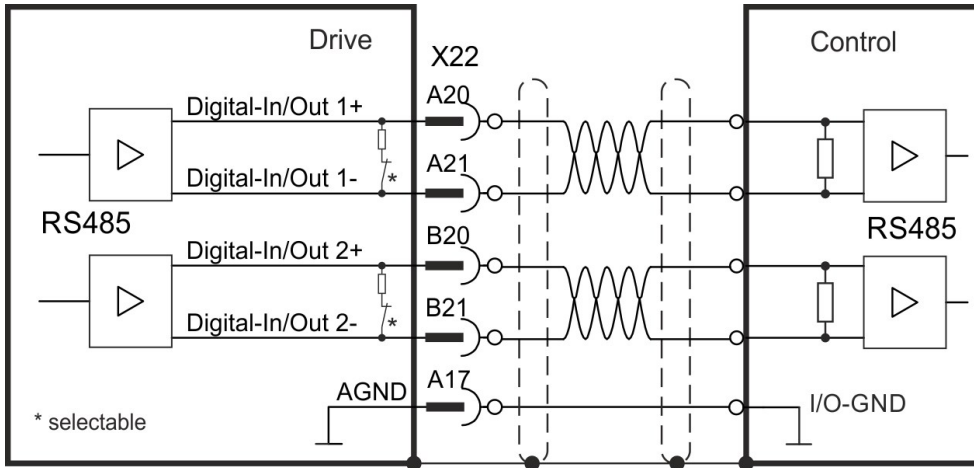

### 8.16.5.4 Digital-In/Out 3 to 6

X23 can be used for digital I/O. The channels can be defined as inputs or outputs. For programming refer to WorkBench.

#### Technical characteristics if configured as output

- RS485, reference common line is 0V
- No wire break detection
- Digital IN/OUT 3/4: Selectable DC termination for differential or single ended output
- Digital IN/OUT 5/6: AC termination for single ended output
- Update rate: 250  $\mu$ s

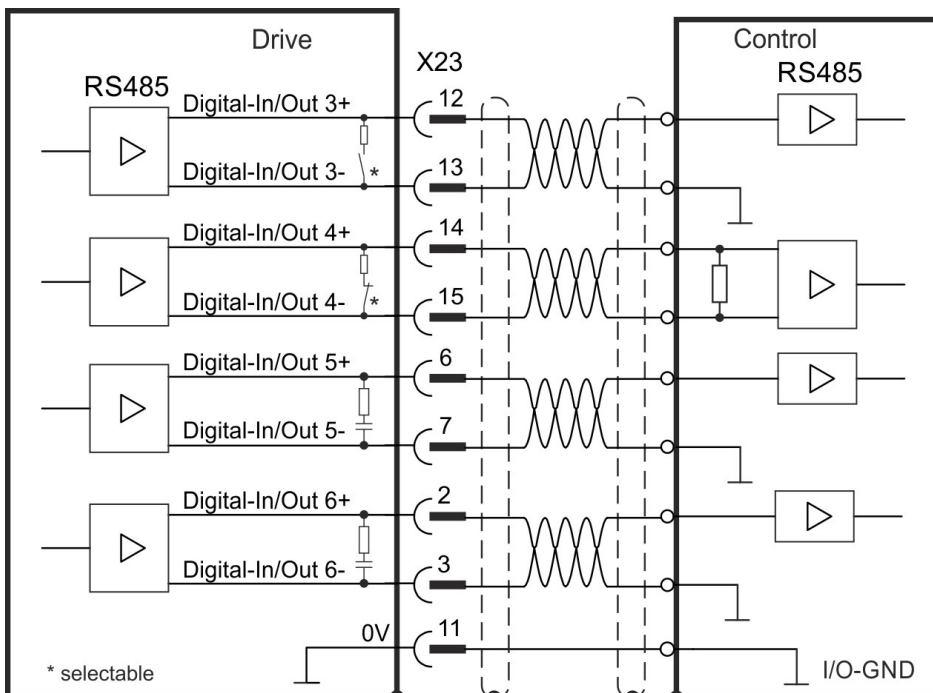

### 8.16.5.5 Digital-Out 9, Relay contacts

Digital-Out 9 is programmable with WorkBench.

By default, the output function is defined as ready to operate output by action parameter.

**NOTICE**

If an inductive load (relay or similar) is used, a freewheeling diode must be added to the load.

#### Technical characteristics

- Relay output, max. 30 VDC or 42 VAC, 1 A
- Galvanic isolation for 24 VDC from PE
- Time to close: max. 10 ms
- Time to open: max. 10 ms

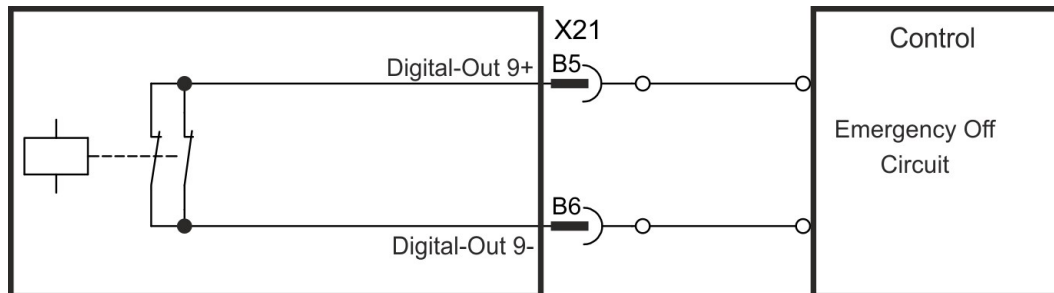

## 9 Setup

---

<b>9.1 Important Notes</b> .....	<b>163</b>
<b>9.2 Guide to drive setup</b> .....	<b>164</b>
<b>9.3 Switch-On and Switch-Off Behavior</b> .....	<b>170</b>
<b>9.4 Fault and Warning Messages</b> .....	<b>177</b>
<b>9.5 Troubleshooting</b> .....	<b>178</b>



## 9.1 Important Notes

### NOTICE

Only professional personnel with extensive knowledge in the fields of electrical engineering and drive technology are allowed to test and set up the drive.



### **DANGER** Lethal Voltage!

There is a danger of serious personal injury or death by electrical shock. Lethal danger exists at live parts of the device.

- Built-in protection measures such as insulation or shielding may not be removed.
- Work on the electrical installation may only be performed by trained and qualified personnel, in compliance with the regulations for safety at work, and only with switched off mains supply, and secured against restart.
- In normal operation, the cabinet door must be closed and the device must not be touched.



### **WARNING** Automatic Restart!

Risk of death or serious injury for humans working in the machine. The drive might restart automatically after power on, voltage dip or interruption of the supply voltage, depending on the parameter setting. If parameter AXIS#.ENDEFAULT is set to 1,

- then place a warning sign ("WARNING: Possible Automatic Restart" or similar) to the machine.
- Ensure, that power on is not possible, while humans are in a dangerous zone of the machine.



### **CAUTION** High Temperature!

Risk of minor burns. The heat sink of the drive can reach temperatures up to 80°C in operation.

- Check the heat sink temperature before handling the drive.
- Wait until the heat sink has cooled down to 40°C before touching it.

### NOTICE

If the drive has been stored for more than 1 year, you must re-form the capacitors in the DC bus link circuit. Re-forming procedures are described in the KDN ([Forming](#)).

### NOTE

Additional information on setting up the equipment:

- Programming parameters and control loop behavior are described in the AKD2G User Manual (Online Help), see [Configuring the Command Source and Operating Mode](#).
- The setup of any fieldbus is described in the corresponding manual on the DVD.

## 9.2 Guide to drive setup

### NOTICE

Setup must be done in two major steps:

1. Drive setup (this section). This section presents an example to test the drive initially. If the drive (motor, feedback, control circuits, I/Os) is well parameterized, then proceed with the
2. Functional Safety setup (→ # 189).

### 9.2.1 Initial Drive Test Procedure

#### 9.2.1.1 Unpacking, mounting, and wiring the AKD2G

1. Unpack the drive and accessories.
2. Mount the drive.
3. Wire the drive or apply the minimum wiring for drive testing as described below.
4. Make sure you have on hand the following information about the drive components:
  - rated mains supply voltage
  - motor type (motor data, if the motor type is not listed in the motor database)
  - feedback unit built into the motor (type, poles/lines/protocol)
  - moment of inertia of the load

#### 9.2.1.2 Minimum wiring for drive test without load, example

### NOTICE

This wiring diagram based on default settings is for general illustration only and does not fulfill any requirements for EMC, functional safety, or functionality of your application.

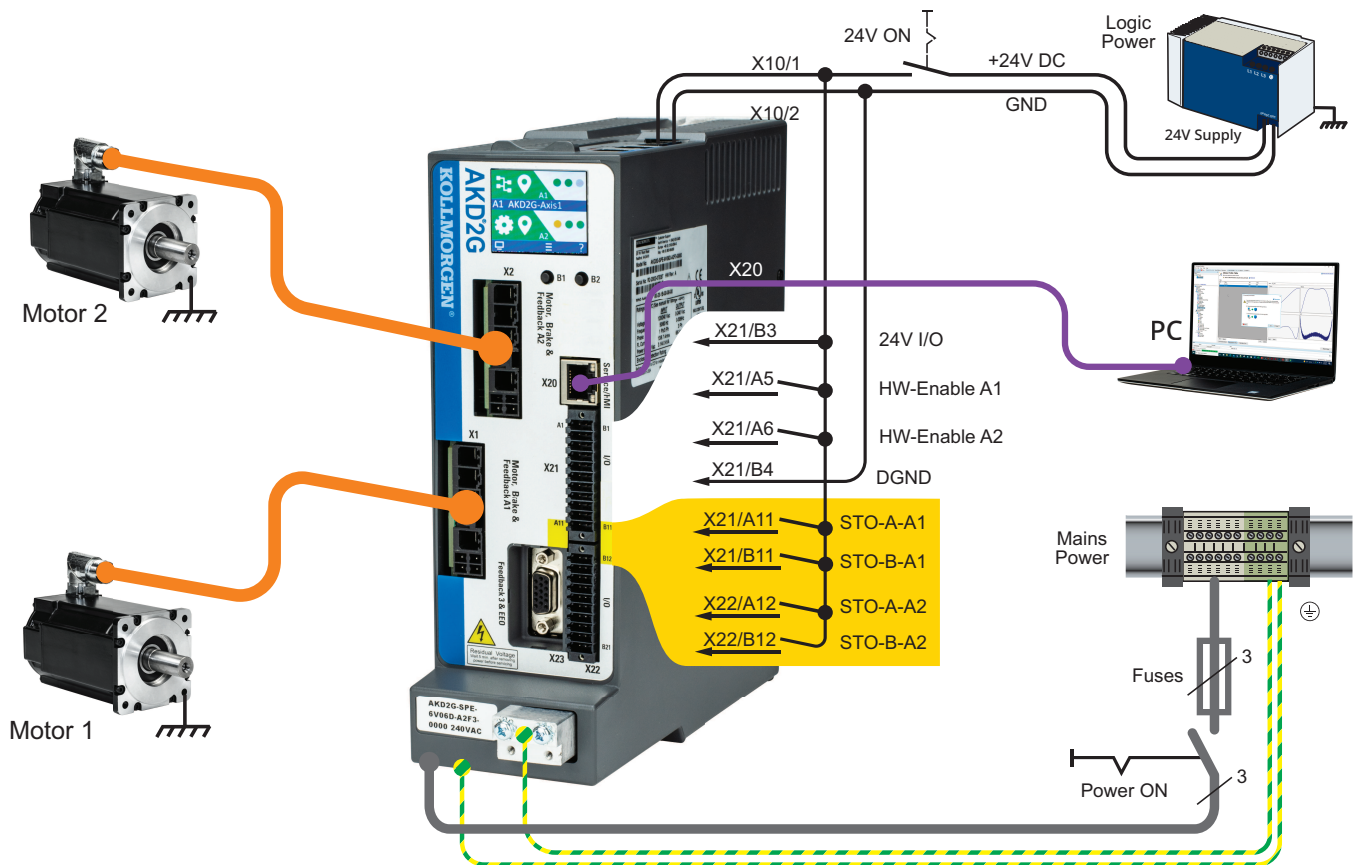

### 9.2.1.3 Confirm connections (example: directly to PC)

You can turn on logic power to the drive through the X10 connector (mains power voltage is not needed for communications).

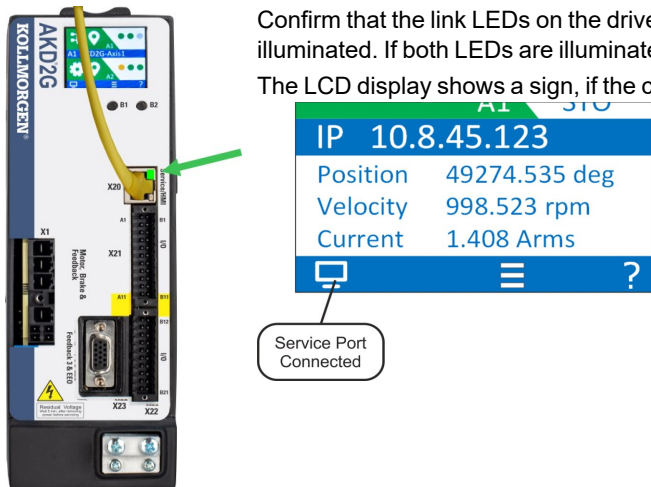

Confirm that the link LEDs on the drive (green LED on the RJ45 connector) and on your PC are both illuminated. If both LEDs are illuminated, then you have a working electrical connection.

The LCD display shows a sign, if the connection between AKD2G and WorkBench is active.

Use WorkBench to configure the drive by using the service interface.

### 9.2.1.4 System integration

#### MAC Address

The unique MAC address is pre-defined by the manufacturer (see nameplate).

#### Service IP Address

The AKD2G service port X20 supports auto-IP, DHCP and static IP addressing.

The drive is delivered with IP address 0.0.0.0. Depending on the connection (switch or PC) either DHCP or auto-IP mechanism assigns a unique IP address.

WorkBench uses the IP address to detect AKD2G devices in the LAN and start communication. With WorkBench you can set a static IP address for the drive (parameter *IP.ADDRESS*).

#### EtherCAT Node Address

The EtherCAT node address is assigned automatically by the EtherCAT master.

#### CAN Node ID

Set a CAN node ID for the drive in WorkBench (parameter *CANBUS.NODEID*).

#### PROFINET

The station name and IP address must be set manually through the PROFINET master.

### 9.2.1.5 Install and start WorkBench

WorkBench is available from the DVD included with the drive. WorkBench is also available on the Kollmorgen Website: [www.kollmorgen.com](http://www.kollmorgen.com). Select the install file and follow the instructions given by the installer.

Once installation is complete, click the WorkBench icon to start the program.

### 9.2.1.6 Setup the axis in WorkBench

Use the setup wizard and

1. Connect the axis
2. Setup the axis
3. Save the parameter set to the drive

Refer to the WorkBench Online Help for details.

### 9.2.1.7 Enable the axis (Hardware)

1. Switch 24 V to the STO inputs (X21/A11-B11 for axis 1 or X21/A12-B12 for axis 2)
2. Switch 24 V to the digital inputs for Hardware Enable Axis 1 (X21/A5) or 2 (X21/A6).

### 9.2.1.8 Move the motor axis

1. Select the Axis in WorkBench
2. Under Motion, select **Service Motion**
3. Select **Reversing**, check the default velocity and time settings for plausibility
4. Select **Start**.

### 9.2.1.9 Tune the axis

Details see *WorkBench Online Help*

## 9.2.2 WorkBench Installation

This chapter describes the installation of the WorkBench software for AKD2G drives. Kollmorgen offers training and familiarization courses on request.

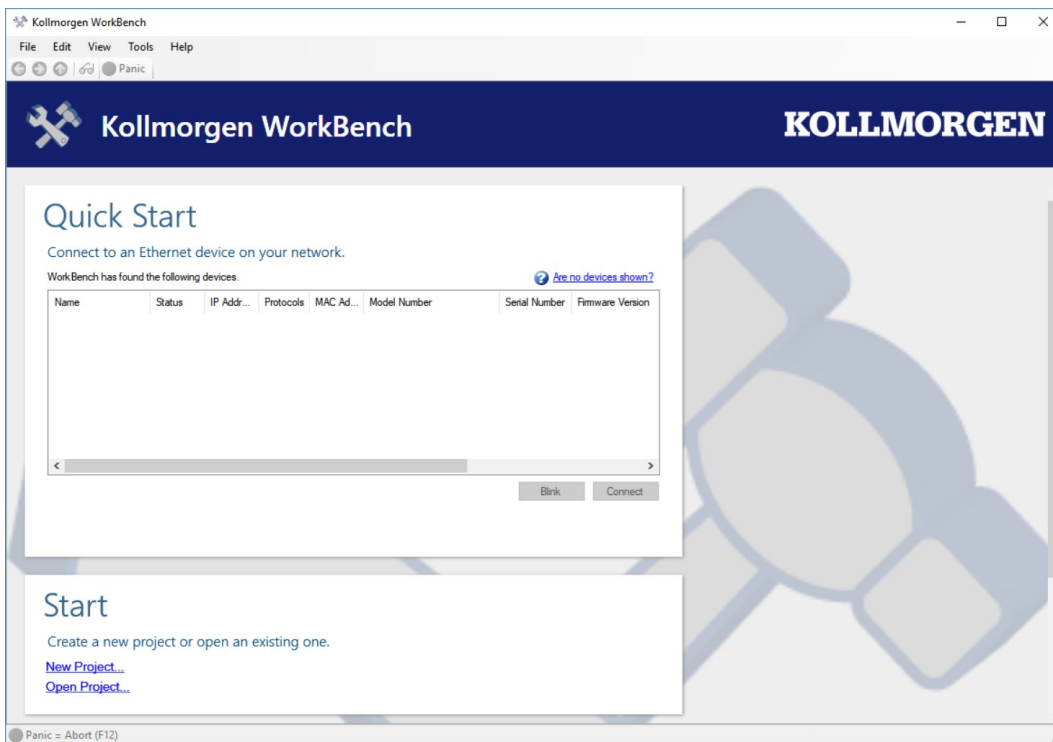

### 9.2.2.1 Use as directed

With the software to set up your drive you can alter and save the operating parameters for the AKD2G series of drives. The attached drive can be set up with the help of this software. During this procedure the drive can be controlled directly by the service functions.

Only professional personnel who have the relevant expertise (→ # 15) are permitted to carry out online parameter setting for a drive that is running.

Sets of data that have been stored on data media are not safe against unintended alteration by other persons. The use of unchecked data can result in unexpected movement. After loading a set of data always validate parameters which are relevant for the application before enabling the drive.

### 9.2.2.2 Software description

Each drive must be configured according to the requirements of your machine. For most applications you can use a PC and WorkBench (the software to setup your drive) to set up the operating conditions and parameters for your drive.

An EtherNet cable connects the PC with the drive (→ # 148) WorkBench establishes the communication between PC and drive.

Please find the software to set up your drive on the accompanying DVD or in the download area of the Kollmorgen website.

With WorkBench you can

- easily change parameters and directly see what happens with your drive due to a continuous online connection to the drive,
- read important and actual values from the drive which are displayed on the PC (oscilloscope functions),
- save data sets on data media (archiving) and load them onto other drives or use them for backup and
- print data sets.

Most standard feedback systems are plug and play compatible. Motor nameplate data is stored in the feedback device and read by the drive automatically at startup. Non-plug and play Kollmorgen motors are stored in WorkBench and can be loaded with one-click using the Motor screen in the software.

An extensive online help with integrated description of all variables and functions supports you in each situation.

### 9.2.2.3 Hardware requirements

The Service interface (X20, RJ45) of the drive is connected to the EtherNet interface of the PC by an EtherNet cable (→ # 148).

#### Minimum requirements for the PC:

Processor: at least 1 GHz

RAM: 512 MB

Graphics adapter: Windows compatible, color, minimum 1024 x 768 dpi

Drives: hard disk with at least 500 MB free space, DVD drive or download from internet

Interface: one free EtherNet Interface, or Switch port

### 9.2.2.4 Operating systems

#### Windows 7/8/10

WorkBench works with Windows 7, 8 and 10.

DotNet framework 4.8 or higher is required.

Internet Explorer 10 or higher.

#### Unix, Linux

The software does not run on Unix/Linux.

### 9.2.2.5 Installation under Windows 7/8/10

The DVD includes an installation program for WorkBench to setup your drive. The latest software can be downloaded from [www.kollmorgen.com](http://www.kollmorgen.com).

Install the WorkBench as follows:

Autostart function	Instruction
Activated	<ol style="list-style-type: none"> <li>1. Insert the DVD into a free drive. A window with a start screen opens.</li> <li>2. Click on the WorkBench link and follow the instructions.</li> </ol>
Deactivated	<ol style="list-style-type: none"> <li>1. Insert the DVD into a free drive.</li> <li>2. Click <b>Start</b> (task bar), then <b>Run</b>.</li> <li>3. Enter the program call: x:\index.htm (x = correct DVD drive letter).</li> <li>4. Click <b>OK</b> and proceed with step 2 for the activated autostart function.</li> </ol>

### EtherNet interface connection

- Connect the interface cable to an EtherNet interface on your PC or to a switch and to the AKD2G service interface X20 (→ # 148).

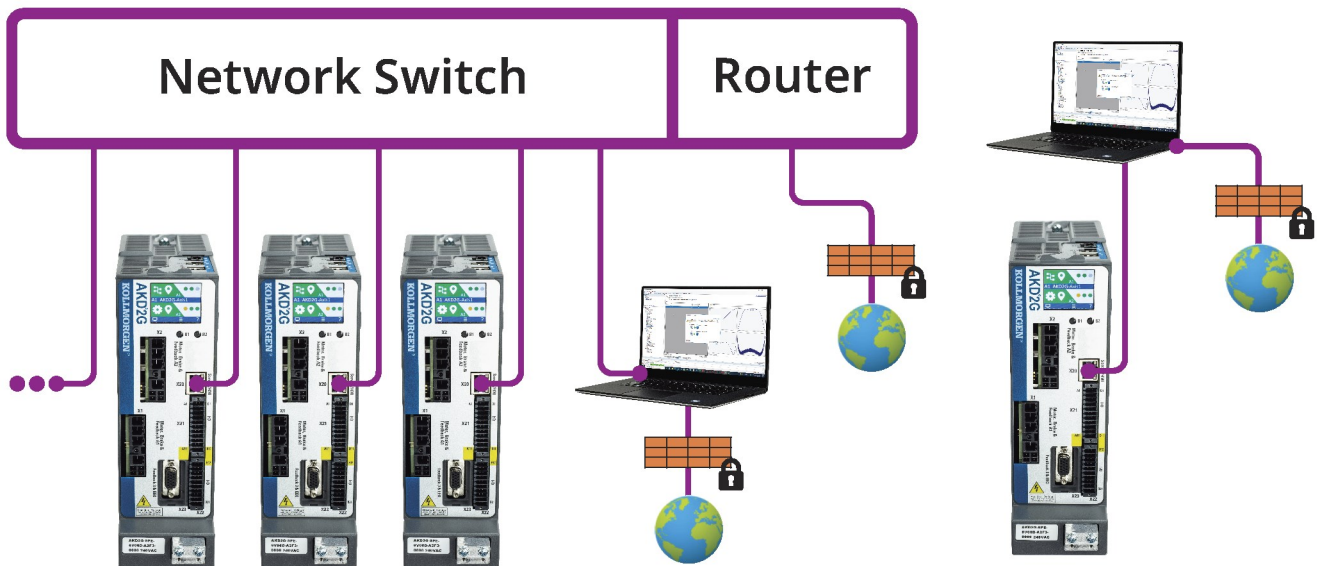

The LCD display shows a sign when AKD2G and WorkBench are connected.

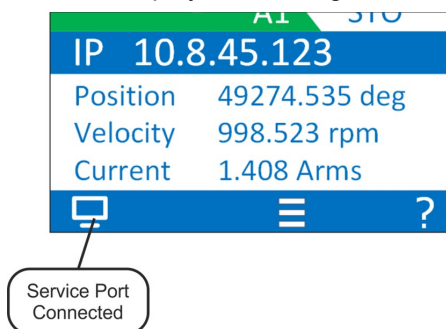

### 9.3 Switch-On and Switch-Off Behavior

This chapter describes the switch-on and switch-off behavior of the AKD2G with STO.

#### Behavior of “holding brake” function

Drives with an enabled holding brake function have a special timing for switching on and off the output stage (→ # 101). Events that remove the AXIS#.ACTIVE signal trigger the holding brake to apply. As with all electronic circuits, the general rule applies that there is a possibility of the internal holding brake module failing.

If the drive detects the motor to be at zero velocity (as configured by AXIS#.ZEROT and AXIS#.ZEROV) or timeout occurs during a stop procedure, the brake is applied. Set parameter AXIS#.MOTOR.BRAKEIMM to 1 with vertical axes, to apply the motor holding brake (→ # 101) immediately after faults or Hardware Disable.

#### Behavior when undervoltage condition is present

The behavior in an undervoltage condition depends on the VBUS.UVMODE setting.

<b>VBUS.UVMODE</b>	DC Bus Undervoltage Mode. Consult the WorkBench Online Help for configuring the parameter.
<b>0</b>	The drive will report a F2007 undervoltage fault any time an undervoltage condition occurs.
<b>1 (default)</b>	The drive will report a warning W2007 if not enabled. The drive will report a fault if the drive is enabled when the condition occurs, or an attempt is made to enable while an under voltage condition occurs.

#### Functional Safety

The drive can be secured to standstill with STO. Even when power is being supplied, the drive shaft is protected against unintentional restart. The chapter “Functional Safety” describes how to use the safety functions (→ # 180).

- Functional safety, e.g. with hanging load (vertical axes), requires an additional brake, controlled for example from the second axis or externally from a safety controller. The brakes can be mapped to an axis with WorkBench.
- The Hardware Enable does not initiate a controlled stop but switches off the power stage immediately.
- Set parameter AXIS#.MOTOR.BRAKEIMM to 1 with vertical axes, to apply the brake immediately after faults or Hardware Disable.



### 9.3.1 Switch-on behavior in standard operation

The diagram below illustrates the correct functional sequence for switching the drive on.

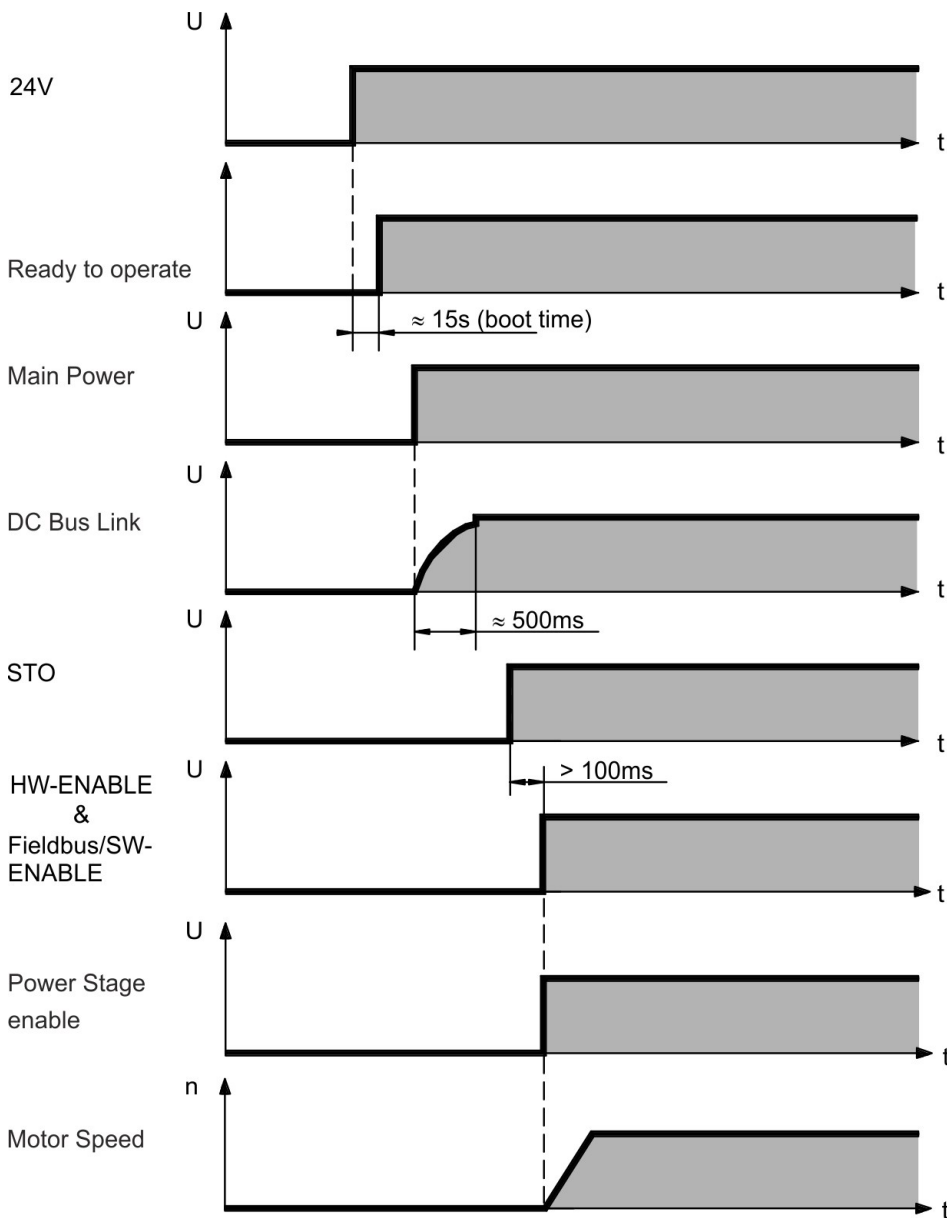

### 9.3.2 Switch-off behavior

**NOTE** The drive's 24V supply must remain constant. STO disables the power stage immediately. Configured digital inputs and fieldbus commands can be used to perform controlled stops.

#### 9.3.2.1 Switch-off behavior using the AXIS#.DIS command

The enable/disable button in WorkBench issues a *AXIS#.DIS* command internally to the drive. See *WorkBench Online Help* for configuring inputs and software commands. Sometimes this enable signal is called "Software Enable" (SW-Enable).

AXIS#.DISMODE	AXIS#.DISMODE controls the behavior of the <i>AXIS#.DIS</i> command issued through WorkBench, or terminal, or fieldbus.
0	Disable axis immediately, if the drive detects the motor to be at zero velocity <i>AXIS#.ZEROV</i> or timeout occurs brake is applied. Category 0 stop according to IEC 60204 (→ # 20).
2	Use controlled stop to disable drive, if the drive detects the motor to be at zero velocity <i>AXIS#.ZEROV</i> or timeout occurs brake is applied. Category 1 stop according to IEC 60204 (→ # 20).

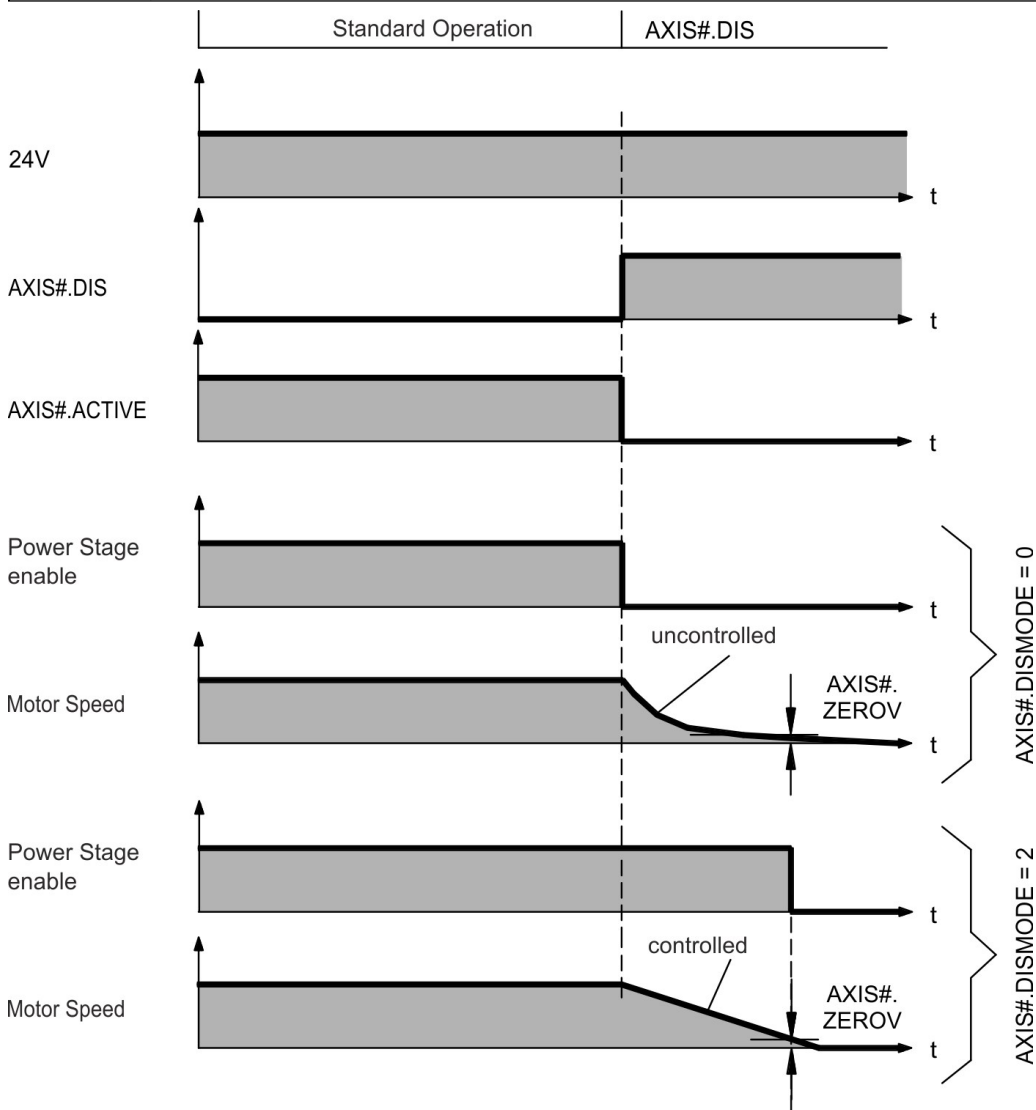

If the drive detects the motor to be at zero velocity (*AXIS#.ZEROV*) or timeout occurs (*AXIS#.ZEROT*), the motor brake is applied (→ # 101).

### 9.3.2.2 Switch-off behavior using a digital input (controlled stop)

This is a category 1 stop according to IEC 60204 (→ # 20).

A digital input can be configured to bring the motor to a controlled stop and then disable the drive and apply the holding brake (if present). See the *WorkBench Online Help* for information on configuring Digital Inputs.

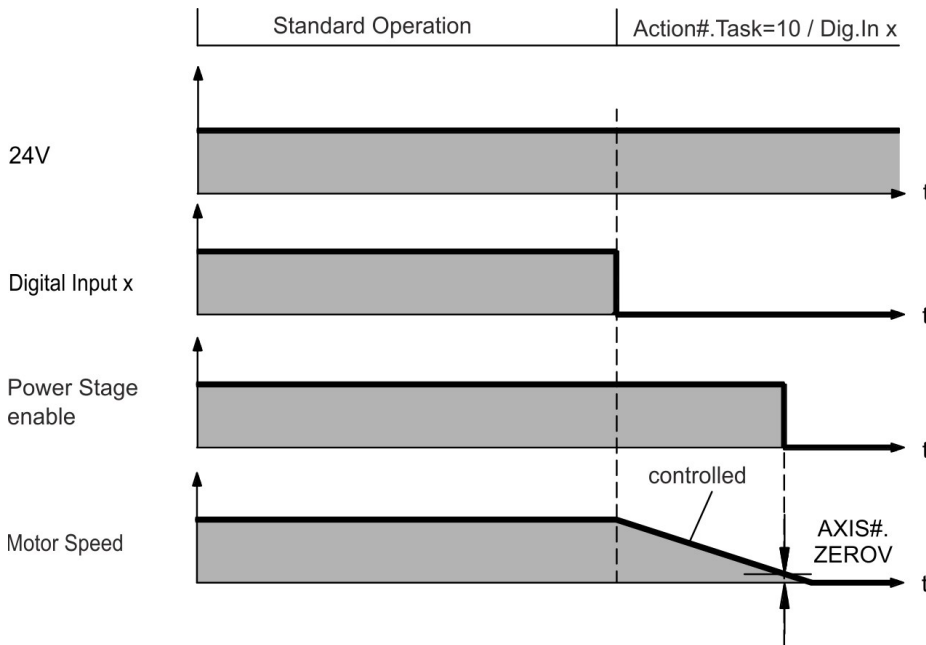

If the drive detects the motor to be at zero velocity (AXIS#.ZEROV) or timeout occurs (AXIS#.ZEROT), the motor brake is applied (→ # 101).

### 9.3.2.3 Switch-off behavior using STO input (uncontrolled stop)

This is a category 0 stop according to IEC 60204 (→ # 20).

The STO input disables the power stage immediately.

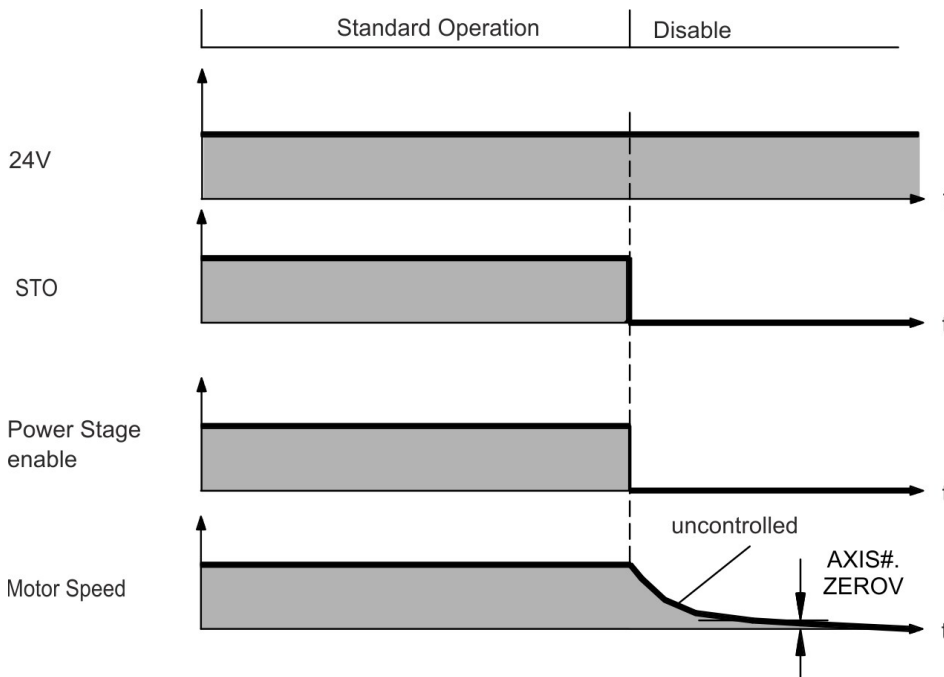

If the drive detects the motor to be at zero velocity (AXIS#.ZEROV) or timeout occurs (AXIS#.ZEROT), the motor brake is applied (→ # 101). Set parameter AXIS#.MOTOR. BRAKEIMM to 1 with vertical axes, to apply the motor holding brake immediately after STO.

**9.3.2.4 Switch-off behavior in the event of a fault**

The behavior of the drive always depends on the fault type and the setting of a number of different parameters (AXIS#.DISMODE, VBUS.UVFTHRESH, AXIS#.ZEROV, and others; see the *WorkBench Online Help* for more details). See the *Drive Fault and Warning Messages and Remedies* section of the *WorkBench User Manual* for a table describing the specific behavior of each fault. The next pages show examples for the possible fault behaviors. The fault relay output (DOUT9) switches the main contactor (Emergency Off circuit).

**Switch-off behavior for faults that cause an immediate power stage disable**

This is a category 0 stop according to IEC 60204 (→ # 20).

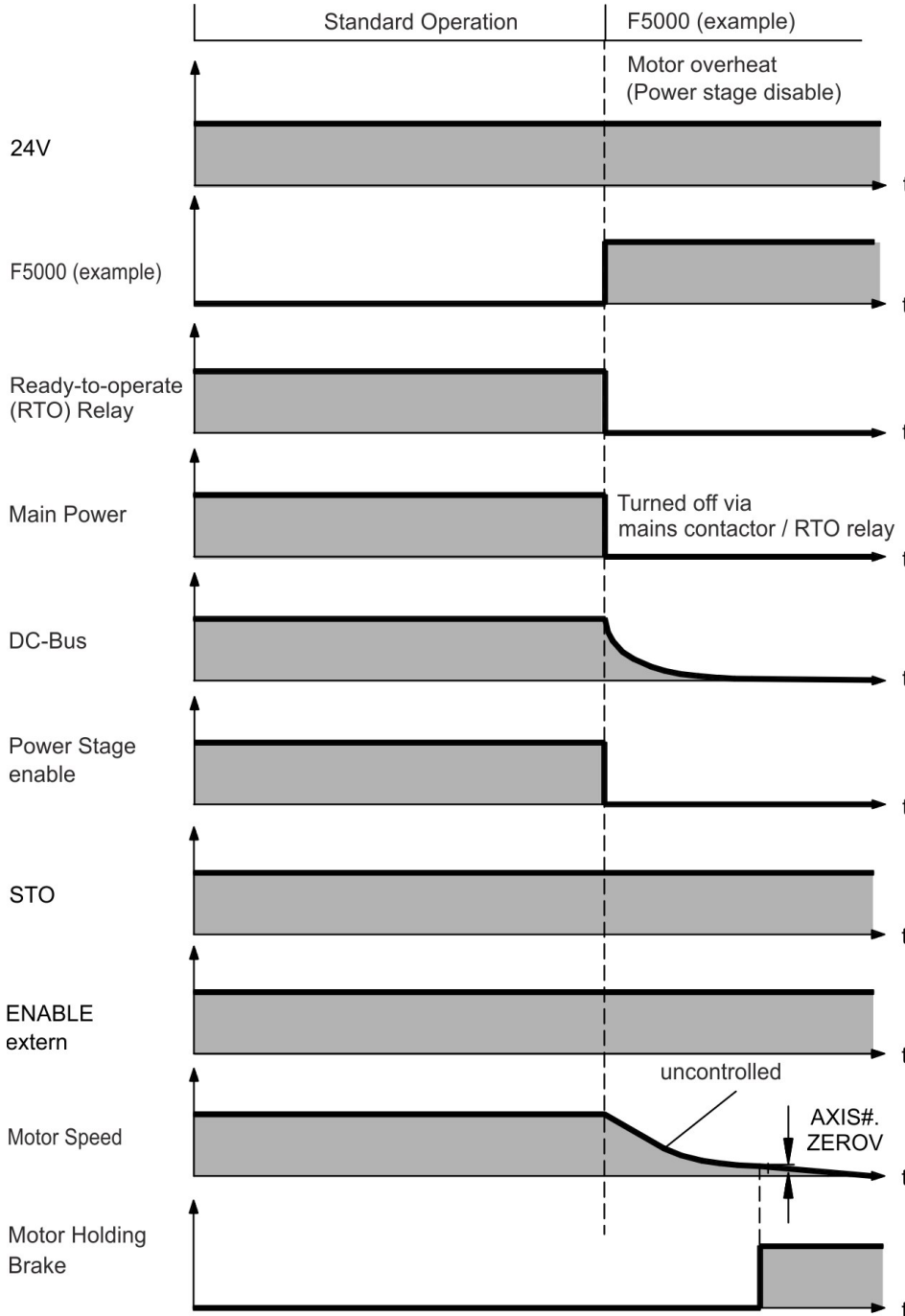

If the drive detects the motor to be at zero velocity (AXIS#.ZEROV) or timeout occurs (AXIS#.ZEROT), the motor brake is applied (→ # 101). Set parameter AXIS#.MOTOR. BRAKEIMM to 1 with vertical axes, to apply the motor holding brake immediately after faults.

### Switch-off behavior for faults that cause dynamic braking

This is a category 2 stop according to IEC 60204 (→ # 20).

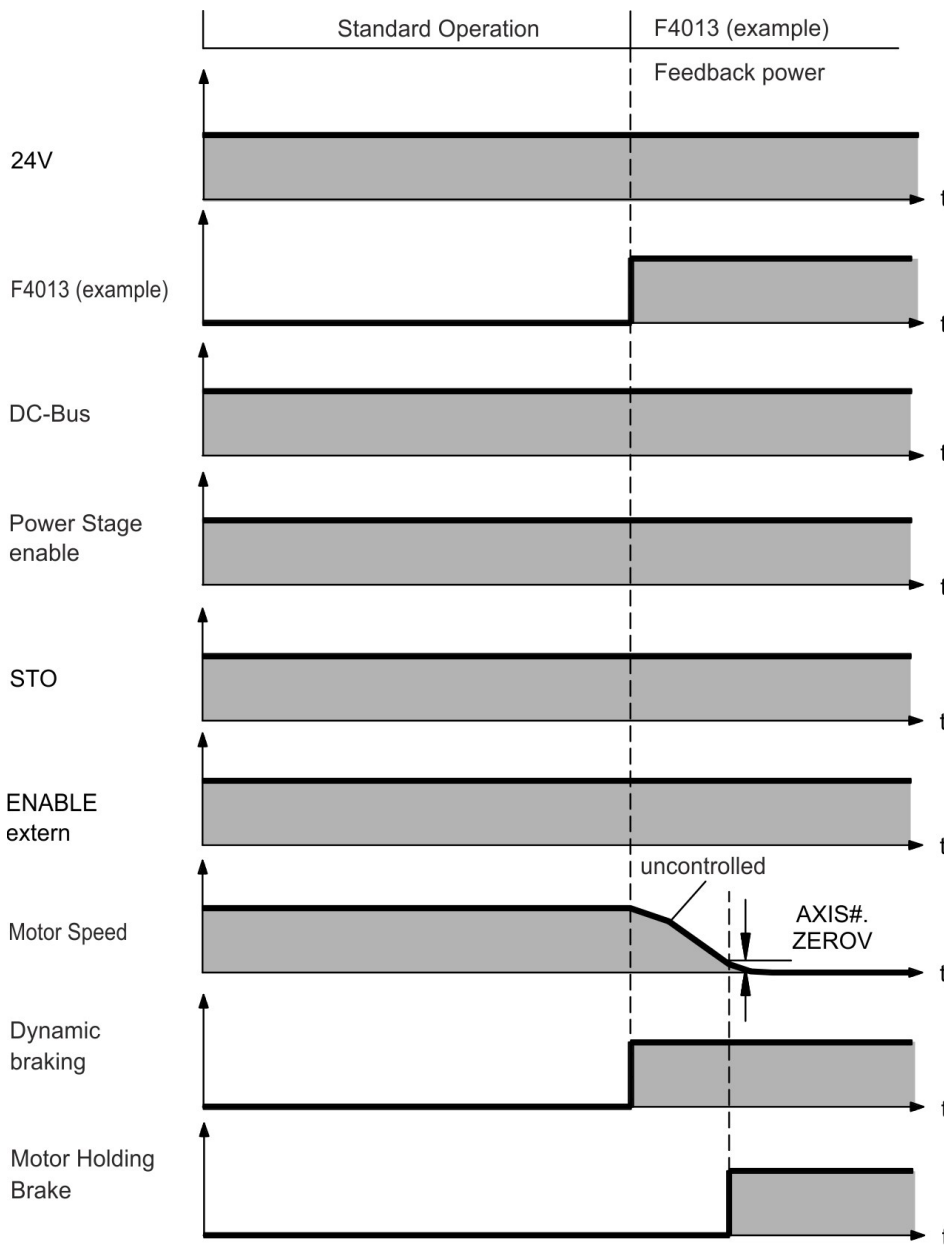

If the drive detects the motor to be at zero velocity (AXIS#.ZEROV) or timeout occurs (AXIS#.ZEROT), the motor brake is applied (→ # 101).

**Switch-off behavior for faults that cause a controlled stop**

This is a category 2 stop according to IEC 60204 (→ # 20).

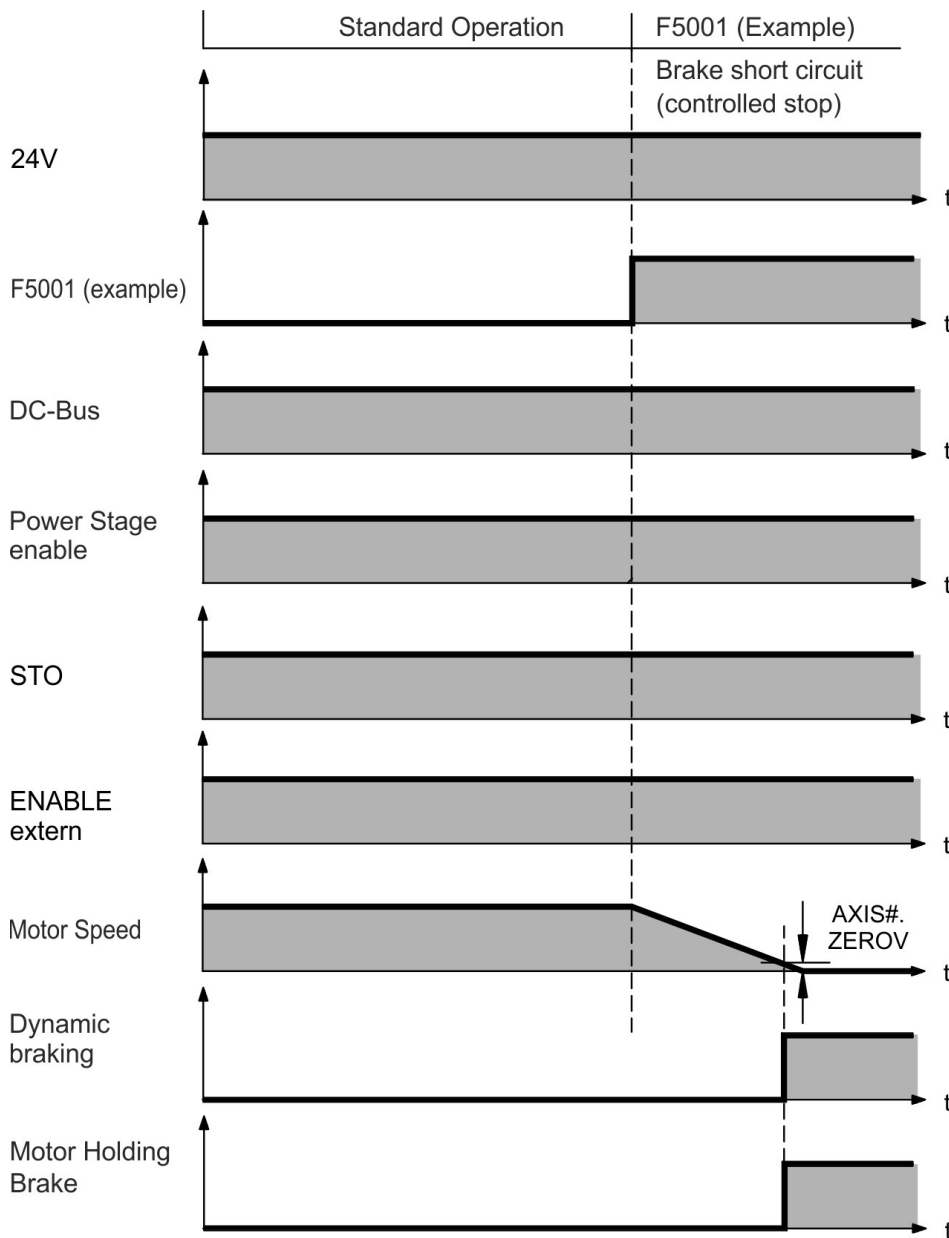

If the drive detects the motor to be at zero velocity (AXIS#.ZEROV) or timeout occurs (AXIS#.ZEROT), the motor brake is applied (→ # 101).

## 9.4 Fault and Warning Messages

### 9.4.1 Fault and warning messages AKD2G

A Fault is generally a notification of a critical system failure which will stop machine operation. Depending on the severity of the fault will depend on which system-stop mechanism is used.

A Warning is generally a notification to the user which is not critical and does not require the machine to immediately shut off.

Faults and Warnings follow the same pattern and are identified by a four digit code:

G G X X, where GG is a two digit group code, and XX is a two digit ID.

GG	Group	GG	Group
10	System	4#	Feedback (# indicates feedback number)
11	File	50	Motor
15	Hardware	55	Wake and Shake
20	Power	60	Motion
25	Temperature	70	Fieldbus
30	Software	90	Safety

The display on the front panel of the drive shows the code of the fault or warning that occurred. Navigate with B1 / B2 to the Fault screen to see a short description of the fault or warning.

Example: dual axes, Fault Axis 2

Example: single axis, Warning Axis 1

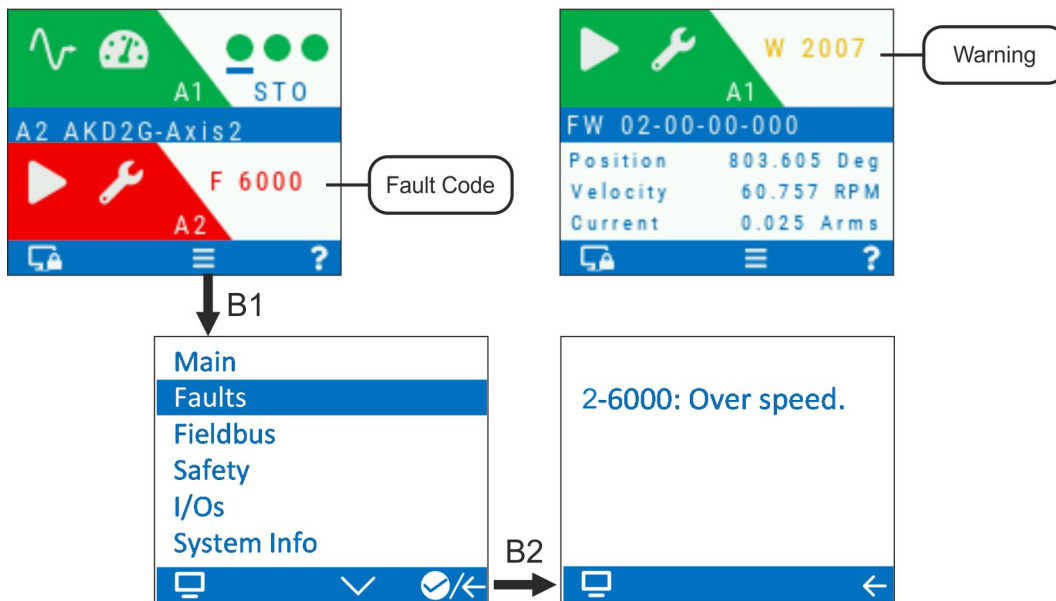

You can retrieve faults on a per-axis basis with the parameter: AXIS#.FAULTS, where # is the Axis number. For retrieving warnings use AXIS#.WARNINGS, or DRV.WARNINGS.

Multiple faults may be present when a fault condition is occurring. Check the WorkBench Fault Screen or read the status of DRV.FAULTS and AXIS#.FAULTS for the entire list of faults.

DRV.FAULTS will return all faults across all axes, with the format #-GGXX where # is the axis number and GGXX is the four digit fault/warning code.

**NOTICE**

Eliminate errors and faults in compliance with work safety rules. Troubleshooting only by qualified and trained staff.

**NOTE**

More information about fault messages, remedy and clearing faults can be found in the WorkBench User Manual.

## 9.5 Troubleshooting

Drive problems occur for a variety of reasons, depending on the conditions in your installation. The causes of faults in multi-axis systems can be especially complex. If you cannot resolve a fault or other issue using the troubleshooting guidance presented below, customer support can give you further assistance.

**NOTICE**

Eliminate errors and faults in compliance with work safety rules. Troubleshooting only by qualified and trained staff.

**NOTE**

More details on the removal of faults can be found in the WorkBench User Manual.

Problem	Possible Causes	Remedy
HMI message: Communication fault	<ol style="list-style-type: none"> <li>wrong cable used, cable plugged into wrong position on drive or PC</li> <li>wrong PC interface selected</li> </ol>	<ol style="list-style-type: none"> <li>plug cable into the correct sockets on the drive and PC</li> <li>select correct interface</li> </ol>
Drive does not enable	<ol style="list-style-type: none"> <li>HW Enable configured but not wired</li> <li>HW or SW Enable not set</li> </ol>	<ol style="list-style-type: none"> <li>connect HW Enable to the selected input</li> <li>Apply 24V to HW Enable and select SW Enable in WorkBench / Fieldbus</li> </ol>
Motor does not rotate	<ol style="list-style-type: none"> <li>drive not enabled</li> <li>software enable not set</li> <li>break in setpoint cable</li> <li>motor phases swapped</li> <li>brake not released</li> <li>drive is mechanically blocked</li> <li>motor pole no. set incorrectly</li> <li>feedback set up incorrectly</li> </ol>	<ol style="list-style-type: none"> <li>apply ENABLE signal</li> <li>set software enable</li> <li>check setpoint cable</li> <li>correct motor phase sequence</li> <li>check brake control</li> <li>check mechanics</li> <li>set motor pole no.</li> <li>set up feedback correctly</li> </ol>
Motor oscillates	<ol style="list-style-type: none"> <li>gain is too high (speed controller)</li> <li>feedback cable shielding broken</li> <li>AGND not wired up</li> </ol>	<ol style="list-style-type: none"> <li>reduce AXIS#.VL.KP (speed controller)</li> <li>replace feedback cable</li> <li>join AGND to CNC-GND</li> </ol>
Drive reports following error	<ol style="list-style-type: none"> <li>I<sub>rms</sub> or I<sub>peak</sub> set too low</li> <li>current or velocity limits apply</li> <li>accel/decel ramp is too long</li> </ol>	<ol style="list-style-type: none"> <li>verify motor/drive sizing</li> <li>verify that AXIS#.IL.LIMITN/P, AXIS#.VL.LIMITN/P are not limiting the drive</li> <li>reduce AXIS#.ACC/AXIS#.DEC</li> </ol>
Motor overheating	<ol style="list-style-type: none"> <li>motor operating above its rating</li> <li>motor current settings incorrect</li> </ol>	<ol style="list-style-type: none"> <li>verify motor/drive sizing</li> <li>verify motor continuous and peak current values are set correctly</li> </ol>
Drive too soft	<ol style="list-style-type: none"> <li>AXIS#.VL.Kp (velocity) too low</li> <li>AXIS#.VL.Ki (velocity) too low</li> <li>filters set too high</li> </ol>	<ol style="list-style-type: none"> <li>increase AXIS#.VL.KP (velocity)</li> <li>increase AXIS#.VL.KI (velocity)</li> <li>refer to documentation regarding reducing filtering (AXIS#.VL.AR*)</li> </ol>
Drive runs roughly	<ol style="list-style-type: none"> <li>AXIS#.VL.Kp (velocity) too high</li> <li>AXIS#.VL.Ki (velocity) too high</li> <li>filters set too low</li> </ol>	<ol style="list-style-type: none"> <li>reduce AXIS#.VL.KP (velocity)</li> <li>reduce AXIS#.VL.KI (velocity)</li> <li>refer to documentation regarding increasing filtering (AXIS#.VL.AR*)</li> </ol>



## 10 Safety Manual for FS1

### Revision History for Safety Manual

Revision	Remarks
S101, 12/2019	Functional Safety Option 1
S102, 04/2020	Default setting: STO active, max. length of unshielded digital I/O lines (3 m), trouble shooting updated, description F9004/9005 updated, SFF = 75%, STO certified
S103, 05/2021	Display screens updated, "Valid for..." info moved from 10.3 to chapter 10 and extended, F9000 cause text updated, AXIS#.SAFE.STO.REPORTFAULT updated
S103, 07/2022	STO fault reaction table improved, PFH value changed in chapter "Safety Properties Overview"

### The Safety Manual is valid for:

AKD2G with Functional Safety Option 1 (FS1):

**AKD2G - xxx - xxxxx - x1xx - xxxx**

Safety Functions: STO; SIL2 PLd, activation by digital I/O

Hardware Revision	Drive Firmware	WorkBench
A	from 2.00	from 2.0

### Contents:

<b>10.1</b>	<b>General Notes</b> .....	<b>180</b>
<b>10.2</b>	<b>Verification</b> .....	<b>183</b>
<b>10.3</b>	<b>Safety Function Option 1 (I/O, SIL2 PLd)</b> .....	<b>183</b>
<b>10.4</b>	<b>Settings</b> .....	<b>189</b>
<b>10.5</b>	<b>Safety Faults, Safety Warnings</b> .....	<b>190</b>
<b>10.6</b>	<b>Functional Safety Parameter Reference</b> .....	<b>192</b>

## 10.1 General Notes

Resulting Functional Safety classification (SIL and/or PL level) is calculated across the drive system. The drive system usually consists of the following:

- motion controller (e.g. AKC/KAS),
- safety controller (e.g. KSM),
- servo drives (AKD2G) and servo motors (e.g. AKM2G),
- motor brakes, feedback systems,
- cables to connect drive and motor,
- sensors/actors

The safety properties listed in this chapter can be reached with Kollmorgen components.

### NOTICE

The user must ensure the compliance of the application with all relevant directives and local electrical code. The user is responsible for implementation and validation of the drive system and safety system. Only properly qualified personnel are permitted to perform installation, setup and verification/validation tasks.

- Mechanical installation: only by qualified personnel with mechanical expertise according to IEC 60417-6183.
- Electrical installation: only by qualified personnel with electrotechnical expertise according to IEC 60417-6182.
- Parameterizing Functional Safety: only by trained personnel with expertise appropriate to the complexity and safety integrity level of the drive system.
- Verification/Validation: only by trained personnel after any changes to the installation. The expertise of the personnel must be appropriate to the complexity and safety integrity level of the drive system.

### NOTE

**Safe State:** In a safe state the drive removes the motor torque is removed from all axes, applies the brake(s), deactivates all of the safe digital outputs, and sets the safe fieldbus connection to the safe state (if applicable).

**Trigger conditions:** I/O failure and internal failure (such as problems detected on the drive or on the safety system itself) lead to safe state.



### **CAUTION** High electrical voltage!

Risk of electrical shock! The safety functions do not provide an electrical separation from the power output. If manual access to the motor or drive power terminals is necessary,

- disconnect the drive from mains supply,
- consider the discharging time of the DC-Bus link,
- ensure the cabinet is safely disconnected and protected against unintended switch-on (for instance, with a lock-out and warning signs).

### 10.1.1 Use as directed

Safety functions are intended to reduce the risk of the machine operation to the required tolerable risk. To achieve functional safety, the wiring of the safety circuits must meet the safety requirements of IEC 60204, ISO 12100 and ISO 13849.

#### NOTICE

- The network the drive is connected to must be secured according to state-of-the-art information technology security requirements.
- The IT specialists shall analyze whether further security requirements are applicable to ensure functional safety.
- The drive firmware can be updated. The parameter sets must be reloaded, verified and proof tested before normal operation is started.
- In certain types of machinery, two motors drive a single mechanical axis. It is the responsibility of the user to ensure that a fault reaction on the first motor-drive set is also carried out on the second motor-drive set and vice versa. Safe I/O and/or a safe fieldbus such as FSoE can be used to achieve this.

### 10.1.2 Prohibited use

The safety functions must not be used if the drive is to be made inactive for Emergency-Off situations. In an Emergency-Off situation, the main relay is switched off by the Emergency-Off button.

The STO function requires two-channel control if the performance level SIL2 / PLd Cat.3 in the system is to be achieved. The connection of a constant 24 VDC voltage to one of the STO inputs is not permitted if the safety function is to be used.

The device does not require maintenance. Opening the device voids the warranty. In case of damage or malfunction, the drive must be sent for repair or replacement if it cannot be repaired.

### 10.1.3 Abbreviations used for functional safety

More abbreviations see (→ # 13).

Abbreviation	Meaning
A#, AXIS#	A# or AXIS# are placeholders for the axis number. Used with parameters (AXIS#.SAFE.STO.ACTIVE) or signal names (STO-A-A#)
(→ # 53)	"see page 53" in this document
→ xyz	"see chapter xyz" in this document
CCF	Common Cause Failure
FS1	Functional Safety Option 1 (STO)
HFT	Hardware Fault Tolerance
MTTFd	Mean time to dangerous failure
OSSD	Output Switching Signal Device
PELV	Protective Extra Low Voltage
PFHd	Probability of dangerous failure per hour
PL	Performance Level
SC	Systematic Capability
SFF	Safe Failure Fraction
SIL	Safety Integrity Level
STO	Safe Torque Off
TM	Mission Time

## 10.1.4 Enclosure, wiring

### Enclosure

Since the drive meets IP20, you must select an enclosure that permits safe operation of the drive. The enclosure must at least meet IP54 .

Transport in accordance with IEC 61800-2	
<b>NOTE</b>	Transport only in the manufacturer's original recyclable packaging.
<b>Temperature</b>	-25 to +70 °C, maximum rate of change 20 K/hour, class 2K3.
<b>Relative Humidity</b>	max. 95% at +40 °C, no condensation, class 2K3.
<b>Shock</b>	<b>NOTICE:</b> Avoid shocks while transporting. AKD2G modules are tested for environmental class 2M1 of IEC 60721-3-2.

Storage in accordance with IEC 61800-2	
<b>Temperature</b>	-25 to +55 °C, maximum rate of change 20 K/hour, class 1K4.
<b>Relative Humidity</b>	5 to 95% , no condensation, class 1K3.

Operation in accordance with IEC 61800-2	
<b>Environmental Class</b>	Environmental class 3K3
<b>Temperature</b>	Internal regen resistor used: <ul style="list-style-type: none"> <li>• 0 to +40 °C under rated conditions</li> <li>• +40 to +60 °C with current derating 3 % per Kelvin</li> </ul> Internal regen resistor not used: <ul style="list-style-type: none"> <li>• 0 to +50 °C under rated conditions</li> <li>• +50 to +60 °C with current derating 2% per Kelvin</li> </ul>
<b>Relative Humidity</b>	5 to 85%, no condensation, IEC 61800-2 class 3K3
<b>Site Altitude</b>	<ul style="list-style-type: none"> <li>• Up to 1000 m above mean sea level (AMSL): no restriction</li> <li>• 1,000 to 2,000 m AMSL: power derating 1.5%/100 m</li> <li>• Maximum altitude: 2000 m AMSL</li> </ul>
<b>Drive EMC Immunity</b>	Increased immunity according to EN 61800-5-2
<b>Drive Pollution Level</b>	Pollution level 2 as per IEC 60664-1
<b>Drive Vibration Class</b>	Class 3M1 according to IEC 61800-2
<b>Drive Shock Class</b>	Class L according to IEC 61800-2
<b>Drive Protection Class</b>	IP20 according to IEC 60529
<b>Enclosure</b>	Minimum cabinet size (WxHxD): 406 x 406 x 254 mm
<b>Enclosure Protection</b>	At least IP 54 according to IEC 60529

### Wiring

Wiring inside the specified enclosure (IP54) must meet the requirements of the standard IEC 60204-1 and ISO 13849-2 (Table D.4). Use copper wires, 0.5 mm<sup>2</sup> (20 awg), wire ferrules. Maximum distance for unshielded I/O lines is 3 m inside the cabinet. If the I/O cable leaves the cabinet, it must be EMC shielded.

Wiring outside the specified enclosure must be laid durably protected from outside damage (for example, by laying the cable in a duct, placed in different sheathed cables, or protected individually by grounding connection).

#### NOTICE

When wiring the digital inputs and outputs, take care that short circuits between the inputs, outputs, or to supply lines are avoided.

## 10.2 Verification

Check and verify the STO wiring (examples (→ # 185)). The installation must be verified by trained personnel after any changes to the installation. The expertise of the personnel must be appropriate to the complexity and safety integrity level of the drive system.

### Diagnostic test

#### NOTICE

You must test the STO function after initial start of the axis, after each intervention into the wiring of the system, or after exchange of one or several components of the drive system. The proof test interval is one year to meet the required PFH.

Precondition: [AXIS#.SAFE.STO.REPORTFAULT](#) = 1

**Warning:** Do not enter hazardous area during proof test!

Method 1, axis remains enabled	Method 2, axis disabled
<ol style="list-style-type: none"> <li>1. Stop the axis to standstill.</li> <li>2. <b>Caution: Block vertical load.</b></li> <li>3. Keep the axis enabled.</li> <li>4. Activate the STO function for example by opening the protective screen.</li> <li>5. The axis displays fault F9000.</li> </ol>	<ol style="list-style-type: none"> <li>1. Stop the axis to standstill.</li> <li>2. <b>Caution: Block vertical load.</b></li> <li>3. Disable the axis.</li> <li>4. Activate the STO function, for example, by opening the protective screen</li> <li>5. The axis displays fault W9000.</li> </ol>

## 10.3 Safety Function Option 1 (I/O, SIL2 PLd)

The safety function STO on the AKD2G with functional safety option 1 is certified.

#### NOTICE

The drive is ready to operate with pre-configured STO function.

### Standards

Standard	Content
ISO 13849:2015	Safety of machinery: Safety-related parts of control systems
IEC 62061:2015	Functional safety of electrical/electronic/programmable electronic safety-related systems

### Available Safety Functions

Abbr.	Function	Activation	Refer to
STO	Safe Torque Off	Safe digital inputs for one or for both axis	(→ # 185)

### 10.3.1 Safety Properties Overview

OSSD test pulses are not required. The inputs however are compatible with safety equipment that emits test pulses. Incoming test pulses of up to 1 ms duration are ignored. The dwell time of the test pulses should not exceed 10%.

The hardware fault tolerance is HFT = 1 according to IEC 61508. Two faults might lead to loss of the safety functions.

The systematic capability according to IEC 61508 for the safety-related subsystems of the drive are SC = 2. TM = 20 Years, SFF = 75%.

Function	ISO 13849-1	MTTF <sub>d</sub> Years	DC <sub>AVG</sub> [%]	IEC 62061	PFH [1/h]	CCF [%]	Response time
STO dual channel	PL d, Cat. 3	≥100	≥60	SIL 2	2.18E-08	>65	< 3.5 ms

### 10.3.2 Technical Data

**NOTE**

Safe inputs are fixed to the STO function.

When STO function (Safe Torque Off) is not needed, then all STO inputs must be connected directly with +24 V. The STO function is then bypassed and cannot be used.

#### I/O hardware data

- Reference ground is DGND
- Galvanic isolation for 60 VDC
- Activation delay about 5  $\mu$ s
- De-activation delay about 500  $\mu$ s
- Use 24 VDC  $\pm$ 15% PELV power supply
- High level 17 VDC to 30 VDC, 5 mA to 6 mA
- Low level 0 VDC to 5 VDC, max. 1 mA

#### Pinout

X21	Signal	Description
A11	STO-A-A1	STO channel A (for axis 1)
B11	STO-B-A1	STO channel B (for axis 1)

Drives with two axes, or option IO or DX:

X22	Signal	Description
A12	STO-A-A2	STO channel A (for axis 2)
B12	STO-B-A2	STO channel B (for axis 2)

#### Parameters

Parameter	Description
<a href="#">AXIS#.SAFE.STO.A</a>	Reads the status of STO input channel A for axis #.
<a href="#">AXIS#.SAFE.STO.B</a>	Reads the status of STO input channel B for axis #.
<a href="#">AXIS#.SAFE.STO.ACTIVE</a>	Reads the STO status of axis #.
<a href="#">AXIS#.SAFE.STO.REPORTFAULT</a>	F9000 and W9000 are triggered for axis # only, if set to 1 (default).

**NOTE**

For parameter description refer to the *Safety Parameters Reference Guide*(→ # 192).

#### Factory Default Settings

- The drive is ready to operate with pre-configured STO function.
- [AXIS#.SAFE.STO.REPORTFAULT](#) is set to 1.

### 10.3.3 STO (Safe Torque Off)

Safe Torque Off description for drive option Functional Safety 1.

STO is suited for SIL 2 according to IEC 62061 and PLd / Cat.3 according to ISO 13849-1. STO is a type A subsystem according to IEC 61508.

STO turns off the drive output stage that powers the motor. STO function corresponds to an uncontrolled stop according to IEC 60204-1, category 0.

#### 10.3.3.1 Important Notes

**NOTICE** The safety properties given in this documentation refers to the device AKD2G with functional safety option 1. The user has to determine the safety properties of the safety chain.



**WARNING Vertical load could fall!**

Serious injury could result when a suspended load is not properly blocked. The drive cannot hold a vertical load when STO is active.

- Add a safe mechanical blocking (for instance, a motor-holding brake).

#### 10.3.3.2 Activation

The digital STO inputs (channel A and B) must be connected to the output of a safety device, which at least meets the requirements of PLd, Cat. 3 according to ISO 13849. Technical data of the safe inputs (→ # 184).

If one of the STO inputs goes open-circuit or 0 V, then power supply to the motor stops within 3.5 ms. The motor will lose all torque and coast to a stop.

If the drive detects that the two STO inputs are in a different state for longer than 100 ms, then a simultaneity fault F9005 occurs (→ # 188).

**NOTE** Review the enclosure and wiring instructions (→ # 182).

#### Wiring example STO single axis, SIL2/PLd, Emergency Stop

Note: [AXIS#.SAFE.STO.REPORTFAULT](#) should be set to 1 if STO is activated by a switch.

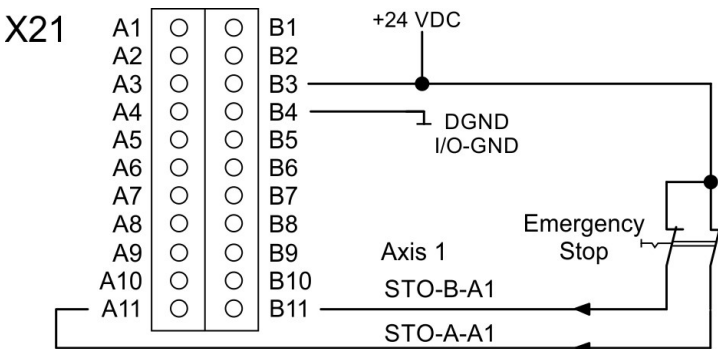

**Wiring example STO dual axis, SIL2/PLd, Safety Control**

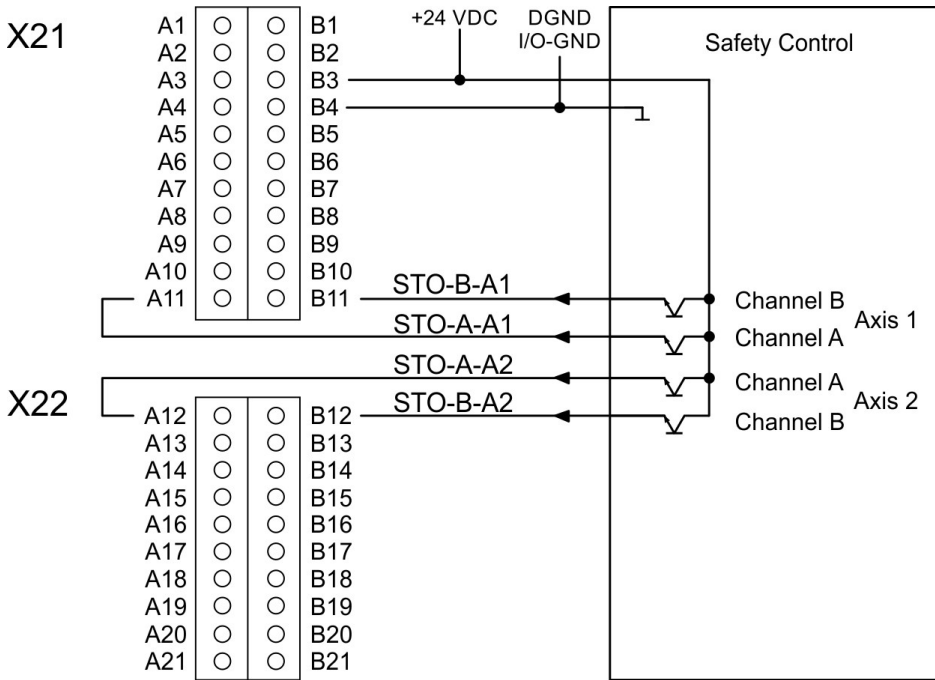

**10.3.3.3 Restart**

Example for Axis 1.

	<b>AXIS1.SAFE.STO. REPORTFAULT = 1</b>	<b>AXIS1.SAFE.STO. REPORTFAULT = 0</b>
Example 1: Axis 1 was disabled, STO is activated	Message W9000 Restart: 1. deactivate STO 2. enable axis 1	Restart: 1. deactivate STO 2. enable axis 1
Example 2: Axis 1 was enabled, STO is activated	Messages W9000 and F9000 Restart: 1. disable axis 1 2. deactivate STO 3. clear fault 4. enable axis 1	Restart: 1. deactivate STO
Example 3: Axis 1 was disabled, STO is activated faulty	Message F9005 Restart: 1. check wiring 2. remedy the cause 3. deactivate STO 4. clear fault 5. enable axis 1	Message F9005 Restart: 1. check wiring 2. remedy the cause 3. deactivate STO 4. clear fault 5. enable axis 1



### 10.3.3.4 Timing

Example for axis 1.

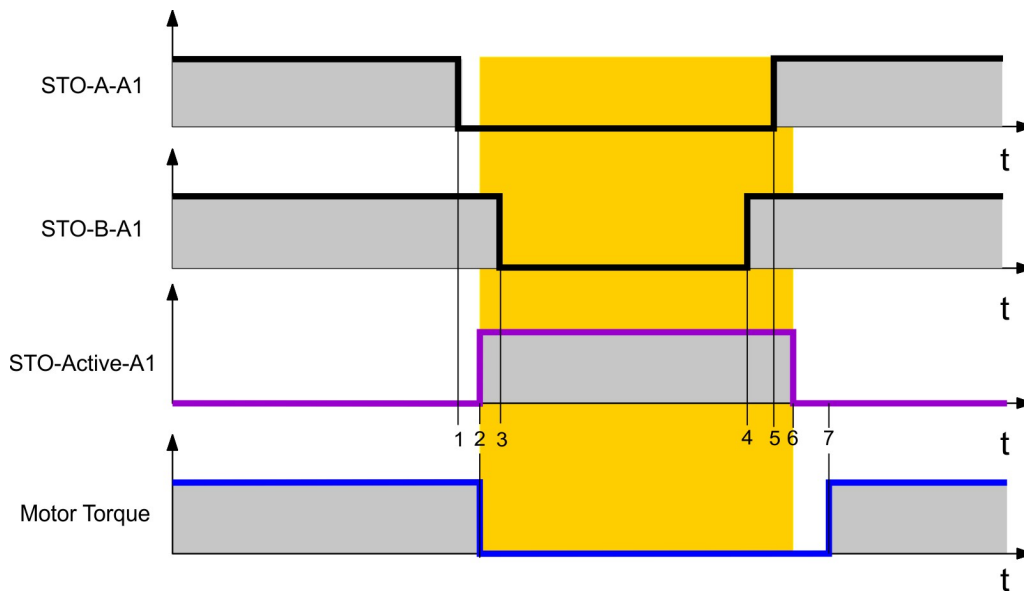

Timing	max	Remarks
t1		STO channel A enabled (0 V)
t1 to t2	2 ms	STO enable delay (response time)
t2		STO active
t3		STO channel B enabled (0 V)
t1 to t3	100 ms	accepted delay between dual channel edges
t4		STO channel B disabled (+24 V)
t5		STO channel A disabled (+24 V)
t4 to t5	100 ms	accepted delay between dual channel edges
t5 to t6	2 ms	STO release delay
t6		STO release
t6 to t7		Zero if <a href="#">AXIS#.SAFE.STO.REPORTFAULT=0</a> Until 'no fault' if <a href="#">AXIS#.SAFE.STO.REPORTFAULT=1</a>
t7		Power section released.

### 10.3.3.5 Safety Diagnostic view in WorkBench

The WorkBench view "Safety Diagnostic" shows the current status on the safe inputs ([AXIS#.SAFE.STO.A](#) / [AXIS#.SAFE.STO.B](#)) and the logical status of the STO function for every axis.

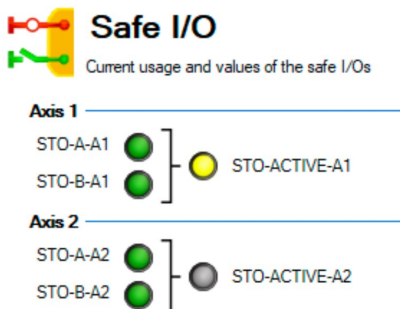

**10.3.3.6 Fault Reaction / Failure Messages**

With the dual-channel control of the STO (SIL2/PLd Cat.3) safety function, the switch-off paths STO-A-A# and STO-B-A# are switched separately by two outputs of a safety controller.

W9000 and F9000 are conditioned by the value of [AXIS#.SAFE.STO.REPORTFAULT](#).

**[AXIS#.SAFE.STO.REPORTFAULT](#) set to 1 (default)**

STO-A-A#	STO-B-A#	ENABLE	Drive Message	Motor Torque	Safe State
0 V	0 V	0 V	W9000	no	yes
0 V	0 V	+24 V	F9000	no	yes
+24 V	+24 V	0 V	-	no	no
+24 V	+24 V	+24 V	-	yes	no
+24 V	0 V	0 V	F9005*	no	yes
+24 V	0 V	+24 V	F9005*	no	yes
0 V	+24 V	0 V	F9005*	no	yes
0 V	+24 V	+24 V	F9005*	no	yes

\* different status of STO-A/B for more than 100 ms  
 A#: A1 for axis 1 or A2 for axis 2.

**[AXIS#.SAFE.STO.REPORTFAULT](#) set to 0**

STO-A-A#	STO-B-A#	ENABLE	Drive Message	Motor Torque	Safe State
0 V	0 V	0 V	W9000	no	yes
0 V	0 V	+24 V	W9000	no	yes
+24 V	+24 V	0 V	-	no	no
+24 V	+24 V	+24 V	-	yes	no
+24 V	0 V	0 V	F9005*	no	yes
+24 V	0 V	+24 V	F9005*	no	yes
0 V	+24 V	0 V	F9005*	no	yes
0 V	+24 V	+24 V	F9005*	no	yes

\* different status of STO-A/B for more than 100 ms  
 A#: A1 for axis 1 or A2 for axis 2.

## 10.4 Settings

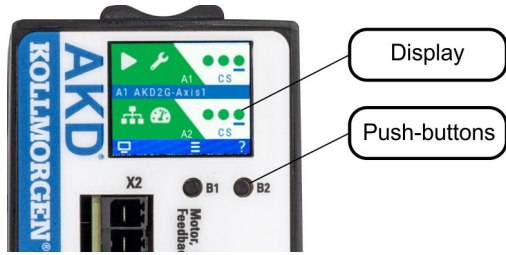

### Display (example for a dual-axis module)

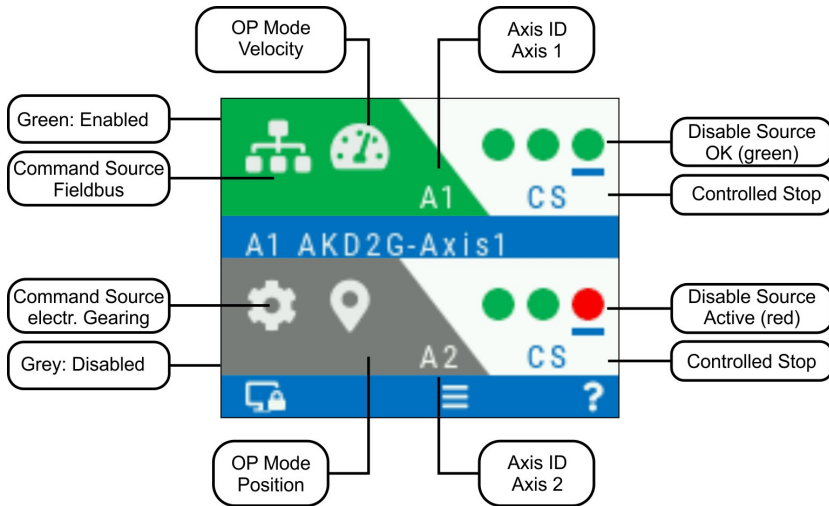

### Push buttons (B1, B2)

A short button press invokes the action corresponding to the symbol directly above the button. On the dashboard for example,

- a short press on B1 causes the menu system to appear, and
- a short press on B2 causes a help screen to appear.
- A long press (greater than 2 seconds) on B2 returns the display to the previous screen.

B1 / B2 Functions	Description
Boot from SD card	Push both buttons during power up to boot with data from the SD card. Press the buttons first, then hold it down while turning on the 24V power supply.
Boot from flash fallback image	Remove the SD card, then press both buttons and hold them down while turning on the 24V power supply to boot from an on-board recovery image.

## 10.5 Safety Faults, Safety Warnings

AKD2G with safety option 1 do not have safety failure modes.

### 10.5.1 LCD Display

The drive offers an LCD display and two push-buttons, B1 and B2, for navigation.

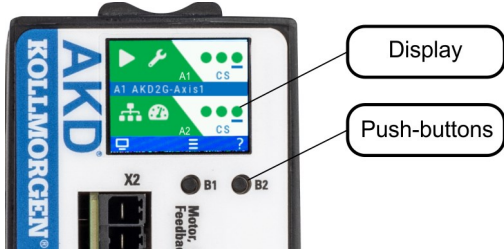

The display on the front panel of the drive shows the code of the fault or warning that occurred. Safety Faults and Warnings follow the same pattern and are identified by a four digit code 90 XX, where 90 is the two digit group code, and XX is a two digit ID.

Navigate with B1 / B2 to the Fault screen to see a short description of the fault or warning. See WorkBench Online Help for details.

Example: dual axes, Fault Axis 2

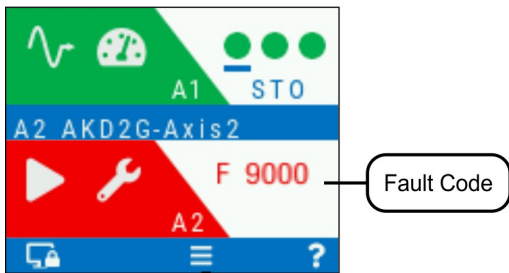

Example: single axis, Warning Axis 1

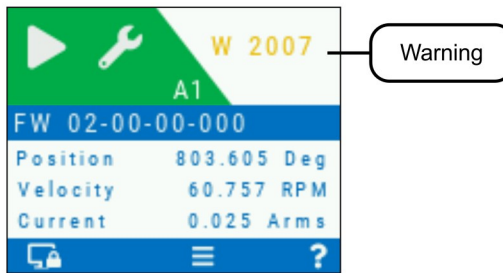

B1

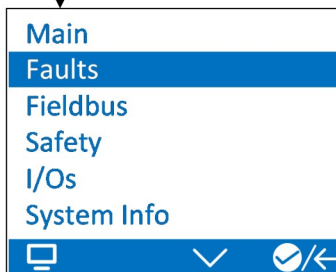

B2

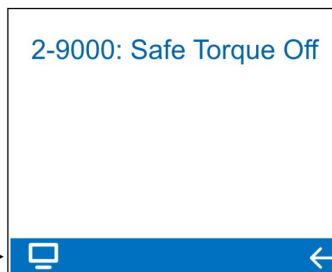

## 10.5.2 Drive Safety Faults

**NOTE**

More information about drive fault messages, remedy and clearing faults can be found in the WorkBench User Manual.

#	Description	Cause	Remedy
F9000	Safe Torque Off	STO function has been triggered while the axis is enabled.	See (→ # 1, STO (Safe Torque Off))
F9004	Safe Torque Off digital and analog lines don't match	Hardware fault on the power board.	Restart drive. If issue persists, contact technical support.
F9005	STO Simultaneity	The two STO inputs did not change state within 100ms of each other.	Check wiring and safety apparatus

## 10.5.3 Safety Warnings

**NOTE**

More information about drive warnings can be found in the WorkBench User Manual.

#	Description	Cause	Remedy
W9000	Safe Torque Off	STO function has been triggered.	See (F9000 , → # 191)

## 10.5.4 Troubleshooting Functional Safety

**NOTICE**

Eliminate errors and faults in compliance with work safety rules. Troubleshooting only by qualified and trained staff.

Problem	Possible Causes	Remedy causes
A group "90" safety fault or safety warning message is visible in the drive LCD display	Refer to the Drive Safety Fault and Warning tables (→ # 191).	
A fault or warning message of another group than "90" is visible in the drive LCD display	Refer to the drive fault and drive warnings tables (→ # 177) and more detailed descriptions in the WorkBench User Manual.	
Safety faults and warnings are not visible/reported	<a href="#">AXIS#.SAFE.STO.REPORTFAULT</a> is set to 0	Set <a href="#">AXIS#.SAFE.STO.REPORTFAULT</a> to 1
STO cannot be deactivated (no torque)	<ol style="list-style-type: none"> <li>External safety device defective.</li> <li>STO wiring defective.</li> <li>Auxiliary voltage low.</li> <li>STO inputs defective.</li> <li>F9004 visible</li> <li>F9005 visible.</li> <li>OSSD pulses too long (&gt;1ms).</li> <li>STO channels are unequal for more than 100ms.</li> </ol>	<ol style="list-style-type: none"> <li>Check external safety device.</li> <li>Check STO wiring for short-circuit or similar.</li> <li>Check voltage level (→ # 184) .</li> <li>Send drive to manufacturer for repair.</li> <li>Send drive to manufacturer for repair.</li> <li>Check safety hardware system.</li> <li>Check safety controller. Switch off OSSD.</li> <li>Check external safety device.</li> </ol>
Drive does not enable	<ol style="list-style-type: none"> <li>STO is still active.</li> </ol>	<ol style="list-style-type: none"> <li>Deactivate STO prior to HW Enable.</li> </ol>

## 10.6 Functional Safety Parameter Reference

### Abbreviations

- Acc. = Access: RO = Read Only, RW = Read/Write, WO = Write Only
- N/A = Not Available, Y = Yes, N = No
- Parameters are sorted alphanumerically

Parameters related to safety functions	Acc.	Default	Parameter Package	CAN over EtherCAT		
				Axis1 Index 0x....	Axis2 Index 0x....	Sub
<a href="#">AXIS#.SAFE.STO.A</a>	RO	N/A	N/A	5007	5107	3
<a href="#">AXIS#.SAFE.STO.ACTIVE</a>	RO	N/A	N/A	5007	5107	2
<a href="#">AXIS#.SAFE.STO.B</a>	RO	N/A	N/A	5007	5107	4
<a href="#">AXIS#.SAFE.STO.REPORTFAULT</a>	RW	1	Drive	5007	5007	1

## 10.6.1 Safety Parameters, sorted alphanumeric

### 10.6.1.1 AXIS#.SAFE.STO.A

#### Description

Indicates the state for STO-A input.

Value	Description
1	24V present (STO inactive, allowed to enable)
0	24V not present (STO active, axis disabled)

#### Context

For complete STO information refer to " STO (Safe Torque Off)" (→ # 185).

#### Versions

Action	Version	Notes
Implemented	02-00-00-000	

#### General Information

Type	Read Only
Units	N/A
Range	0 or 1
Default Value	N/A
Data Type	Integer
Stored in Non-Volatile Memory	No

### 10.6.1.2 AXIS#.SAFE.STO.B

#### Description

Indicates the state for STO-B input.

Value	Description
1	24V present (STO inactive, allowed to enable)
0	24V not present (STO active, axis disabled)

#### Context

For complete STO information refer to " STO (Safe Torque Off)" (→ # 185).

#### Versions

Action	Version	Notes
Implemented	02-00-00-000	

#### General Information

Type	Read Only
Units	N/A
Range	0 or 1
Default Value	N/A
Data Type	Integer
Stored in Non-Volatile Memory	No

### 10.6.1.3 AXIS#.SAFE.STO.ACTIVE

#### Description

Indicates the Safe Torque Off (STO) state of the axis.

Value	Description
1	STO active (inputs +0V)
0	STO inactive (inputs 24V)

#### Context

For complete STO information refer to " STO (Safe Torque Off)" (→ # 185).

#### Versions

Action	Version	Notes
Implemented	02-00-00-000	

#### General Information

Type	Read Only
Units	N/A
Range	0 or 1
Default Value	N/A
Data Type	Integer
Stored in Non-Volatile Memory	No

### 10.6.1.4 AXIS#.SAFE.STO.REPORTFAULT

#### Description

This parameter controls whether a Safe Torque Off (STO) fault F9000 will be created when STO is activated while the axis is enabled. The STO warning W9000 is always generated if this parameter is 1 and the STO function is active.

Value	Description
1	W9000 / F9000 are generated when axis is enabled and an STO occurs (default)
0	W9000 / F9000 are not generated

#### Context

For complete STO information refer to " STO (Safe Torque Off)" (→ # 185).

#### Versions

Action	Version	Notes
Implemented	02-00-00-000	

#### General Information

Type	Read/Write
Units	N/A
Range	0 or 1
Default Value	1
Data Type	Integer
Stored in Non-Volatile Memory	Yes



# 11 Approvals

**NOTICE** If the drive is labeled Beta, approvals are pending.

---

<b>11.1 Conformance with UL/cUL</b> .....	<b>196</b>
<b>11.2 Conformance with EU</b> .....	<b>198</b>
<b>11.3 Conformance with UK</b> .....	<b>199</b>

## 11.1 Conformance with UL/cUL

### 11.1.1 3-12 A drives

This drive is listed under UL (Underwriters Laboratories Inc.) file number **E141084**.

USL, CNL – Power conversion equipment (NMMS, NMMS7)

USL (United States Standards - Listed): Indicates Investigated to United States Standard for Power Conversion Equipment, UL 61800-5-1.

CNL (Canadian National Standards - Listed): Indicates investigation to Canadian Standard for Industrial Control Equipment, CAN/CSA - C22.2, No. 274-17.

#### UL Markings / Marquages UL

English	Français
<ul style="list-style-type: none"> <li>Integral solid state short circuit protection does not provide branch circuit protection. Branch circuit protection must be provided in accordance with the National Electrical Code and any additional local codes.</li> </ul>	<ul style="list-style-type: none"> <li>Une protection de court-circuit à semi-conducteur intégrale ne fournit pas de protection de la dérivation. Il convient de garantir une protection de la dérivation conforme au NEC et aux réglementations locales en vigueur.</li> </ul>
<ul style="list-style-type: none"> <li>This product is suitable for use on a circuit capable of delivering not more than 10kA (SCCR) when protected by class J fuses or circuit breakers, and of delivering not more than 65kA (SCCR) when protected by semi-conductor fuses.</li> </ul>	<ul style="list-style-type: none"> <li>Ce produit peut être utilisé sur un circuit capable de délivrer un maximum de 10 kA (SCCR) lorsqu'il est protégé par des fusibles ou des disjoncteurs de classe J, et de délivrer un maximum de 65 kA (SCCR) lorsqu'il est protégé par des fusibles à semi-conducteurs.</li> </ul>
<ul style="list-style-type: none"> <li>Suitable for motor group installation on a circuit capable of delivering not more than 65 kA rms symmetrical.</li> </ul>	<ul style="list-style-type: none"> <li>Convient pour une installation de groupe moteur sur un circuit capable de délivrer pas plus de 65 kA rms symétriques.</li> </ul>
<ul style="list-style-type: none"> <li>These drives provide solid state motor overload protection at 125% of the rated FLA current. The drive overload trip point should not be set to less than 10% above the motor rated current:  <math>AXIS\#.IL.FOLDFTHRESHU \geq 1.1 * AXIS\#.MOTOR.ICONT.</math> </li> </ul>	<ul style="list-style-type: none"> <li>Ces variateurs offrent une protection contre les surcharges de moteur à semi-conducteur à 125 % du courant FLA nominal. Le point de déclenchement en surcharge du variateur ne doit pas être réglé à moins de 10% au dessus du courant nominal du moteur:  <math>AXIS\#.IL.FOLDFTHRESHU \geq 1,1 * AXIS\#.MOTOR.ICONT.</math> </li> </ul>
<ul style="list-style-type: none"> <li>These devices are intended to be used in a pollution degree 2 environment and must be placed in an enclosure with min. size of 16 x 16 x 10 inches</li> </ul>	<ul style="list-style-type: none"> <li>Ces appareils sont prévus pour une utilisation dans un environnement de pollution de niveau 2 et doivent être placés dans une enceinte avec min. taille de 406 x 406 x 254 mm</li> </ul>
<ul style="list-style-type: none"> <li>Surrounding air temperature 40°C. Refer to chapter "Ambient Conditions", for other temperature ratings.</li> </ul>	<ul style="list-style-type: none"> <li>La température de l'air ambiant 40 °C. Voir chapitre "Ambient Conditions", pour connaître les autres températures.</li> </ul>
<ul style="list-style-type: none"> <li>Use minimum 75°C copper wire.</li> </ul>	<ul style="list-style-type: none"> <li>Utilisez un fil en cuivre 75 °C minimum.</li> </ul>
<ul style="list-style-type: none"> <li>Connector X3 torque requirements: <ul style="list-style-type: none"> <li>- screw terminals, tightening torque 18 in-lbs</li> <li>- locking screw, tightening torque 3.5 in-lbs</li> </ul> </li> </ul>	<ul style="list-style-type: none"> <li>Exigences de couple du connecteur X3: <ul style="list-style-type: none"> <li>- bornes à vis, couple de serrage 2 Nm</li> <li>- vis de blocage, couple de serrage 0,35 Nm</li> </ul> </li> </ul>
<ul style="list-style-type: none"> <li><b>CAUTION Risk of Electrical Shock!</b> Capacitors can have dangerous voltages present up to five minutes after switching off the supply power. For increased safety, measure the voltage in the DC bus link and wait until the voltage is below 50 V.</li> </ul>	<ul style="list-style-type: none"> <li><b>ATTENTION: Risque de choc électrique!</b> Des tensions dangereuses peuvent persister dans les condensateurs jusqu'à cinq minutes après la mise hors tension. Pour plus de sécurité, mesurez la tension dans la liaison de bus CC et attendez qu'elle soit inférieure à 50 V.</li> </ul>

### 11.1.2 7V24S 24 A drives

This drive is listed under UL (Underwriters Laboratories Inc.) file number **E141084**.

USL, CNL – Power conversion equipment (NMMS, NMMS7)

USL (United States Standards - Listed): Indicates Investigated to United States Standard for Power Conversion Equipment, UL 61800-5-1.

CNL (Canadian National Standards - Listed): Indicates investigation to Canadian Standard for Industrial Control Equipment, CAN/CSA - C22.2, No. 274-17.

#### UL Markings / Marquages UL

English	Français
<ul style="list-style-type: none"> <li>Integral solid state short circuit protection does not provide branch circuit protection. Branch circuit protection must be provided in accordance with the National Electrical Code and any additional local codes.</li> </ul>	<ul style="list-style-type: none"> <li>Une protection de court-circuit à semi-conducteur intégrale ne fournit pas de protection de la dérivation. Il convient de garantir une protection de la dérivation conforme au NEC et aux réglementations locales en vigueur.</li> </ul>
<ul style="list-style-type: none"> <li>This product is suitable for use on a circuit capable of delivering not more than 5kA (SCCR) when protected by class J fuses, or not more than 10kA (SCCR) when protected by circuit breakers.</li> </ul>	<ul style="list-style-type: none"> <li>Ce produit peut être utilisé sur un circuit capable de délivrer au maximum 5kA (SCCR) lorsqu'il est protégé par des fusibles de classe J, ou au maximum 10kA (SCCR) lorsqu'il est protégé par des disjoncteurs.</li> </ul>
<ul style="list-style-type: none"> <li>Suitable for motor group installation on a circuit capable of delivering not more than 5kA rms symmetrical when protected by class J fuses, or not more than 10kA rms symmetrical when protected by circuit breakers.</li> </ul>	<ul style="list-style-type: none"> <li>Convient à l'installation d'un groupe de moteurs sur un circuit capable de délivrer un courant symétrique ne dépassant pas 5 kA eff. lorsqu'il est protégé par des fusibles de classe J, ou un courant symétrique ne dépassant pas 10 kA eff. lorsqu'il est protégé par des disjoncteurs.</li> </ul>
<ul style="list-style-type: none"> <li>These drives provide solid state motor overload protection at 125% of the rated FLA current. The drive overload trip point should not be set to less than 10% above the motor rated current:  <math>AXIS\#.IL.FOLDFTHRESHU \geq 1.1 * AXIS\#.MOTOR.ICONT.</math> </li> </ul>	<ul style="list-style-type: none"> <li>Ces variateurs offrent une protection contre les surcharges de moteur à semi-conducteur à 125 % du courant FLA nominal. Le point de déclenchement en surcharge du variateur ne doit pas être réglé à moins de 10% au dessus du courant nominal du moteur:  <math>AXIS\#.IL.FOLDFTHRESHU \geq 1,1 * AXIS\#.MOTOR.ICONT.</math> </li> </ul>
<ul style="list-style-type: none"> <li>These devices are intended to be used in a pollution degree 2 environment and must be placed in an enclosure with min. size of 600 x 600 x 350 mm</li> </ul>	<ul style="list-style-type: none"> <li>Ces appareils sont prévus pour une utilisation dans un environnement de pollution de niveau 2 et doivent être placés dans une enceinte avec min. taille de 600 x 600 x 350 mm</li> </ul>
<ul style="list-style-type: none"> <li>Surrounding air temperature 40°C. Refer to chapter "Ambient Conditions", for other temperature ratings.</li> </ul>	<ul style="list-style-type: none"> <li>La température de l'air ambiant 40 °C. Voir chapitre "Ambient Conditions", pour connaître les autres températures.</li> </ul>
<ul style="list-style-type: none"> <li>Use minimum 75°C copper wire.</li> </ul>	<ul style="list-style-type: none"> <li>Utilisez un fil en cuivre 75 °C minimum.</li> </ul>
<ul style="list-style-type: none"> <li>Connector X3A/X3B torque requirements: <ul style="list-style-type: none"> <li>- screw terminals, tightening torque 18 in-lbs</li> <li>- locking screw, tightening torque 3.5 in-lbs</li> </ul> </li> </ul>	<ul style="list-style-type: none"> <li>Exigences de couple du connecteur X3A/X3B: <ul style="list-style-type: none"> <li>- bornes à vis, couple de serrage 2 Nm</li> <li>- vis de blocage, couple de serrage 0,35 Nm</li> </ul> </li> </ul>
<ul style="list-style-type: none"> <li><b>CAUTION Risk of Electrical Shock!</b> Capacitors can have dangerous voltages present up to five minutes after switching off the supply power. For increased safety, measure the voltage in the DC bus link and wait until the voltage is below 50 V.</li> </ul>	<ul style="list-style-type: none"> <li><b>ATTENTION: Risque de choc électrique!</b> Des tensions dangereuses peuvent persister dans les condensateurs jusqu'à cinq minutes après la mise hors tension. Pour plus de sécurité, mesurez la tension dans la liaison de bus CC et attendez qu'elle soit inférieure à 50 V.</li> </ul>

## 11.2 Conformance with EU

### NOTE

EU Declarations of Conformity can be found on the Kollmorgen website.

The drives have been tested by an authorized testing laboratory in a defined configuration, using the system components that are described in this documentation. Any divergence from the configuration and installation described in this documentation means that the user will be responsible for carrying out new measurements to ensure conformance with regulatory requirements.

Kollmorgen declares the conformity of the product series AKD2G with the following directives:

- EC Directive 2006/42/EU, Machinery Directive  
Used harmonized standard EN 61800-5-2
- EC Directive 2014/35/EU, Low Voltage Directive  
Used harmonized standard EN 61800-5-1
- EC Directive 2014/30/EU, EMC Directive  
Used harmonized standard EN 61800-3

### NOTICE

These devices can cause high-frequency interferences in non industrial environments and may require measures for interference suppression (such as additional external EMC filters).

Maximum distance for unshielded I/O lines is 3 m inside the cabinet. If the I/O cable leaves the cabinet, it must be EMC shielded.

### AKD2G-Sxx-6Vxx

### NOTE

AKD2G-Sxx-6Vxx drives do not have integrated ac line EMC filters. External mains filters are described in the *Accessories Manual* (1~: FN2090, 3~: FN3288).

With external EMC mains filters for noise emission the AKD2G-Sxx-6Vxx meet the noise immunity requirements of the second environmental category (industrial environment).

- Motor cable < 10 m: use filter FN 3288 in industrial environment, category C2.
- Motor cable ≥ 10 m: use filter FN 3288 in industrial environment, category C3.

### AKD2G-Sxx-7Vxx

### NOTE

AKD2G-Sxx-7Vxx drives have integrated EMC filters.

The AKD2G-Sxx-7Vxx meet the noise immunity requirements to the 2nd environmental category (industrial environment).

- AKD2G-Sxx-7V up to 12 Amps:  
Motor cable < 10 m: no filter, in industrial environment, category C3.  
Motor cable < 10 m: use filter FN 3288 in industrial environment, category C2.  
Motor cable ≥ 10 m: use filter FN 3288 in industrial environment, category C3.
- AKD2G-Sxx-7V 24:  
Motor cable < 10 m: no filter, in industrial environment, category C2.  
Motor cable ≥ 10 m: no filter, in industrial environment, category C3.  
Motor cable ≥ 10 m: use filter FN 3288 in industrial environment, category C2.

### 11.2.1 Functional Safety

**NOTE**

TÜV Certificate for Functional Safety can be found on the Kollmorgen website.

Kollmorgen offers 3 levels of functional safety implementation for AKD2G:

- Functional Safety Option 1: STO; SIL2 PLd (→ # 183), safe digital I/O command.
- Functional Safety Option 2: STO, SS1-t, SBC, SBT, SDB; SIL3 PLe , safe digital I/O command or FSoE.
- Functional Safety Option 3: STO, SS1-t, SS1-r, SS2, SOS, SLS, SSM, SSR, SDI, SLA, SAR, SLI, SLP, SCA, SBC, SDB, SBT; SIL3 PLe , safe digital I/O command or FSoE.

This manual is valid for AKD2G drives with Functional Safety Option 1.

### 11.2.2 Conformance with RoHS

AKD2G drives are manufactured in conformance with the Directive 2011/65/EU (RoHS), including Delegated Directive 2015/863/EU for installation into Finished Electrical and Electronic Equipment (EEE). One or more exemptions per Annex III of Directive 2011/65/EU may be applicable.

### 11.2.3 Conformance with REACH

REGULATION (EC) No 1907/2006 OF THE EUROPEAN PARLIAMENT AND OF THE COUNCIL as of 18 December 2006 concerning the Registration, Evaluation, Authorization and Restriction of Chemicals [REACH Regulations]

EU REACH Article 33 – Communication on SVHC identified in the Candidate List of Substances of Very High Concern (SVHC) for Authorisation

Articles used in the construction of AKD2G Drives contain SVHCs in excess of 0.1% weight by weight. [REACH 219 Standard AKD2G.pdf](#)

### 11.2.4 Waste Framework Directive Substances of Concern in Products (SCIP) Database

Standard Products constructed using Articles containing an SVHC in excess of 0.1% weight by weight, have been registered in the SCIP Database. SCIP Registration numbers for Standard Products can be found at [scip-database](#)

## 11.3 Conformance with UK

**NOTE**

Declarations of Conformity can be found on the Kollmorgen website.

Kollmorgen declares the conformity of the product series - with the following regulations:

- S.I. 2008/1597, Supply of Machinery (Safety) Regulations 2008  
Used designated standards EN 61800-5-2
- S.I. 2016/1101, Electrical Equipment (Safety) Regulations 2016  
Used designated standard EN 61800-5-1
- S.I. 2016/1091, Electromagnetic Compatibility Regulations 2016  
Used designated standard EN 61800-3

These products comply with **The Restriction of the Use of Certain Hazardous Substances in Electrical and Electronic Equipment Regulations 2012** for installation in a machine.

**Kollmorgen authorized representative for UK government authority:** Twiflex, Ampthill Road, Bedford, MK42 9RD, UK

## 12 Index

### A

<b>Abbreviations</b> .....	<b>13, 181</b>
<b>Address</b>	
Fieldbus .....	165
MAC .....	165
Service IP .....	165
<b>AKD 2G Family</b> .....	<b>31</b>
<b>Ambient Conditions</b> .....	<b>33</b>
<b>Analog setpoints</b> .....	<b>152</b>
<b>Aux. supply 24V, interface</b> .....	<b>91</b>

### C

<b>Cable and Wire Requirements</b> .....	<b>55</b>
<b>Cable Length</b> .....	<b>55</b>
<b>CANbus</b>	
Baud rate .....	147
Cable .....	145
CANopen interface .....	145
Node address .....	147
Termination .....	147
<b>Commissioning</b> .....	<b>183</b>
<b>Conformance</b>	
CE .....	198
Functional Safety .....	199
REACH .....	199
RoHS .....	199
UK .....	199
UL, cUL .....	196
<b>Connector Position</b> .....	<b>63</b>

### D

<b>DC Bus Capacitance</b> .....	<b>41</b>
<b>DC bus link, interface</b> .....	<b>92</b>
<b>Decommission</b> .....	<b>24</b>
<b>Dimensions</b> .....	<b>49</b>
<b>Disassemble</b> .....	<b>24</b>
<b>Display</b> .....	<b>43</b>
<b>Disposal</b> .....	<b>25</b>
<b>Document revisions</b> .....	<b>202</b>
<b>DSL</b> .....	<b>97</b>
<b>Dynamic Drive Braking</b> .....	<b>40</b>

### E

<b>EEO</b> .....	<b>139</b>
<b>Electronic Gearing</b> .....	<b>139</b>
<b>Emergency Off</b> .....	<b>20</b>
<b>Emergency Stop Function</b> .....	<b>20</b>
<b>Emulated Encoder Output</b> .....	<b>139</b>
<b>Enclosure (FS)</b> .....	<b>182</b>
<b>EtherCAT</b> .....	<b>142</b>
<b>EtherNet</b>	
Modbus TCP Protocol .....	149
<b>EtherNet Fieldbus</b> .....	<b>142</b>

<b>EtherNet/IP</b> .....	<b>144</b>
--------------------------	------------

### F

<b>Factory Default Setting</b> .....	<b>184</b>
<b>Fault messages</b> .....	<b>177</b>
<b>Feedback Connection</b> .....	<b>104</b>
<b>Functional Safety (FS)</b> .....	<b>179</b>
<b>Functional Safety 1 (FS1)</b> .....	<b>183</b>
<b>Fusing</b>	
24V supply .....	91
Brake resistor .....	95
DC Bus Link .....	93
Mains supply .....	85

### G

<b>Grounding</b> .....	<b>53</b>
<b>Grounding Plates</b> .....	<b>62</b>

### H

<b>Hardware requirements WorkBench</b> .....	<b>168</b>
<b>Hiperface DSL</b> .....	<b>97</b>

### I

<b>I/O Connection</b> .....	<b>150</b>
<b>Initial Drive Test</b> .....	<b>164</b>
<b>Inputs</b>	

Analog .....	152
Basic Data .....	151
Digital .....	154

### Installation

Electrical .....	51
Mechanical .....	47
Software WorkBench .....	169

<b>Installation, Setup, Normal Operation</b> .....	<b>23</b>
--	-----------

### L

<b>Leakage current</b> .....	<b>19</b>
------------------------------	-----------

### M

<b>Mains supply, interface</b> .....	<b>80</b>
<b>Maintenance</b> .....	<b>24</b>
<b>Master-Slave</b> .....	<b>141</b>
<b>Mating Connectors</b> .....	<b>54</b>
<b>Mechanical Data</b> .....	<b>34</b>
<b>Modbus</b> .....	<b>149</b>
<b>Motor dual cable connection</b> .....	<b>99</b>
<b>Motor Holding Brake Connection</b> .....	<b>101</b>
<b>Motor interface</b> .....	<b>96</b>
<b>Motor single cable connection</b> .....	<b>97</b>

### N

<b>Nameplate</b> .....	<b>27</b>
------------------------	-----------

### O

<b>Operating systems WorkBench</b> .....	<b>168</b>
--	------------

<b>Outputs</b>		
Analog .....	153	X23 .....
Basic Data .....	151	X3 .....
Digital .....	158	X3A .....
Relay .....	161	X3B .....
		X41 .....
<b>P</b>		<b>Trouble Shooting</b> .....
<b>Package supplied</b> .....	<b>27</b>	<b>178</b>
<b>Part Number Scheme</b> .....	<b>28</b>	
<b>PC connection</b> .....	<b>148</b>	<b>U</b>
<b>Product Safety</b> .....	<b>14</b>	<b>UL Markings</b> .....
<b>PROFINET</b> .....	<b>143</b>	<b>196-197</b>
<b>Prohibited Use</b>		<b>Use as directed</b>
Functional Safety .....	181	Drive .....
General .....	18	Functional Safety .....
<b>Pushbuttons</b> .....	<b>43</b>	WorkBench Setup Software .....
		167
<b>R</b>		<b>V</b>
<b>Re-forming</b> .....	<b>163</b>	<b>Ventilation</b> .....
<b>REACH</b> .....	<b>199</b>	<b>33</b>
<b>Regen circuit</b> .....	<b>40</b>	<b>Verification</b> .....
<b>Regen resistor</b> .....	<b>95</b>	<b>183</b>
<b>Regeneration Braking</b> .....	<b>40</b>	
<b>Relay</b> .....	<b>161</b>	<b>W</b>
<b>Repair</b> .....	<b>25</b>	<b>Warning Messages</b> .....
<b>RoHS</b> .....	<b>199</b>	<b>177</b>
		<b>Warning note labels</b> .....
		<b>18</b>
		<b>Wiring</b> .....
		<b>54</b>
		<b>X</b>
		<b>X23 / X41 Feedback Wiring Pinout Diagrams</b> <b>112</b>
		<b>X41 Feedback Wiring Pinout Diagrams</b> .....
		<b>127</b>
<b>S</b>		
<b>Safety</b>		
Functional Safety .....	179	
Product Safety .....	14	
<b>Safety Faults</b> .....	<b>190</b>	
<b>Safety Instructions</b>		
Drive Setup .....	163	
Electrical Installation .....	52	
General .....	15	
Mechanical Installation .....	48	
<b>Safety Properties</b> .....	<b>183</b>	
<b>Safety Warnings</b> .....	<b>190</b>	
<b>SD Card Slot</b> .....	<b>46</b>	
<b>Service Interface</b> .....	<b>148</b>	
<b>Setup</b> .....	<b>163</b>	
<b>Setup Software</b> .....	<b>167</b>	
<b>SFA</b> .....	<b>125</b>	
<b>SFD3</b> .....	<b>97</b>	
<b>Shield connection</b> .....	<b>59</b>	
<b>Shielding</b> .....	<b>53</b>	
<b>Shock-hazard protection</b> .....	<b>19</b>	
<b>Site</b> .....	<b>33</b>	
<b>STO</b> .....	<b>185</b>	
<b>Stop Function</b> .....	<b>20</b>	
<b>Switch-on, switch-off behavior</b> .....	<b>170</b>	
<b>Symbols used</b> .....	<b>12</b>	
<b>T</b>		
<b>Tightening torque</b>		
X1, X2 .....	69	

## 13 Record of document revisions

Edition	Remarks
A, 12/2019	First edition
B, 04/2020	Electrical data updated, UL markings updated, default setting: STO active, connector tightening torque added to connector pin assignments, regen resistor wiring updated, AXIS#.ZEROx keywords updated for stop diagrams, X1/X2 feedback voltage 11V, X23 max. current 350mA, FS trouble shooting updated, SFA voltage/current values, continuous brake power of external regen resistor reduced, CE: external EMC mains filters for 7V models, max. cable length for unshielded I/O lines, 24V supply with X10T, SFF=75%, PROFINET added, EtherNet/IP added, X22 digital feedbacks added, breakers for 7V models removed
C, 07/2020	Performance data table corrected, mounting M/P values synchronized, X23/X41 pinout Step/Dir&CW/CCW updated, chapter CAN termination improved, PROFINET/EtherNet-IP label CHx->Portx, UL Markings updated, Modbus added
D, 05/2021	SFA shielding, Low Voltage DC Operation note, display screens updated, device front view updated, PROFINET certified, regen resistor fusing: FPS removed, SSI feedbacks on X22/X23 added
E, 07/2022	SD Card text updated, Letter of Volatility link added, chapter "Shielding on drive" improved, Incr. Encoder feedback on X21 added, BiSS-C and SSI feedbacks on X41 (SFA) added, new motor connector image, chapter "Motion Bus interface" updated, PROFINET certified and available, chapter "Gearing" restructured, chapter "Feedback connector" restructured, SCCR rating for MV breaker changed, EtherNet/IP table updated, chapter "Mechanical Installation": Texts restructured and dimension table adapted, chapter "Mains supply": semi-conductor added, fusing chapter restructured, EAC approval removed, max. cable length per feedback type added, X23 feedback connector graphic expanded, conformity with UK added
F, 06/2023	7V24S drive contents added, including updated cover image, connector position image, general wiring diagrams, specifications and data, X3A and X3B connector content, X4 and X5 content, individual X23 / X41 feedback wiring diagrams and specifications added, added connection to various mains supply network pages, addition to part number scheme, corrected table formatting, added connector options availability table.





## About KOLLMORGEN

Kollmorgen is a leading provider of motion systems and components for machine builders. Through world-class knowledge in motion, industry-leading quality and deep expertise in linking and integrating standard and custom products, Kollmorgen delivers breakthrough solutions that are unmatched in performance, reliability and ease-of-use, giving machine builders an irrefutable marketplace advantage.



Join the [Kollmorgen Developer Network](#) for product support. Ask the community questions, search the knowledge base for answers, get downloads, and suggest improvements.

### North America KOLLMORGEN

201 West Rock Road  
Radford, VA 24141, USA

**Web:** [www.kollmorgen.com](http://www.kollmorgen.com)  
**Mail:** [support@kollmorgen.com](mailto:support@kollmorgen.com)  
**Tel.:** +1 - 540 - 633 - 3545  
**Fax:** +1 - 540 - 639 - 4162

### Europe KOLLMORGEN Europe GmbH

Pempelfurtstr. 1  
40880 Ratingen, Germany

**Web:** [www.kollmorgen.com](http://www.kollmorgen.com)  
**Mail:** [technik@kollmorgen.com](mailto:technik@kollmorgen.com)  
**Tel.:** +49 - 2102 - 9394 - 0  
**Fax:** +49 - 2102 - 9394 - 3155

### South America KOLLMORGEN

Avenida João Paulo Ablas, 2970  
Jardim da Glória, Cotia – SP  
CEP 06711-250, Brazil

**Web:** [www.kollmorgen.com](http://www.kollmorgen.com)  
**Mail:** [contato@kollmorgen.com](mailto:contato@kollmorgen.com)  
**Tel.:** +55 11 4615-6300

### China and SEA KOLLMORGEN

Room 302, Building 5, Lihpao Plaza,  
88 Shenbin Road, Minhang District,  
Shanghai, China.

**Web:** [www.kollmorgen.cn](http://www.kollmorgen.cn)  
**Mail:** [sales.china@kollmorgen.com](mailto:sales.china@kollmorgen.com)  
**Tel.:** +86 - 400 668 2802  
**Fax:** +86 - 21 6248 5367

## 14 Requirements to User Documentation, Revision 1.12

Requirements migrated from Map Safety Manual Plan 9D00-0620 (revision 0.5)

### 14.1 SDRS/SSRS

ID (green=done for all FS)	Requirements	Realized (green=done for FSx)
WI-267 WI-2826	The manual shall be created according to <ul style="list-style-type: none"> <li>•IEC 61508-2, annex D for E/e/PE safety-related systems and</li> <li>•IEC 61508-3, annex D - not applicable, because the software will not be identified as element which is sold separately. The software will always be distributed as part of FS2 or FS3.</li> </ul>	Details see 14.2 "IEC 61508-2 Annex D Requirements to User Documentation"
WI-231, WI-232, WI-233, WI-234, WI-235, WI-240, WI-2763	The drive shall be mounted inside a cabinet with an ingress protection of at least IP 54. The drive shall not be used in an altitude more than 2000 m over sea level.	<b>FS1/2/3</b> (Enclosure, wiring, → # 182)
WI-238	Increased EMC immunity according to IEC 61326-1	<b>FS1/2/3</b> (Increased immunity according to EN 61800-5-2, → # 182)
WI-268	The drive will safely ensure a holding position, as long as configured this way. <ul style="list-style-type: none"> <li>•Any brake shall be connected to the SBC interface.</li> <li>•The end customer (machine operator) is responsible for the execution of the safe brake test</li> </ul>	<b>FS1</b> : not applicable
WI-593	The safety manual shall state the required training of the personnel and the placement of the lines for the safe inputs. The installation shall be validated after any changes to the installation.	<b>FS1</b> (Check and verify the STO wiring (examples (→ # 185)). The installation must be verified by trained personnel after any changes to the installation. The expertise of the personnel must be appropriate to the complexity and safety integrity level of the drive system., → # 183)
WI-705, WI-838	The safety manual shall instruct the user to replace the component instead of repairing it.	<b>FS1/2/3</b> (The device does not require maintenance. Opening the device voids the warranty. In case of damage or malfunction, the drive must be sent for repair or replacement if it cannot be repaired., → # 181)
WI-761	The drive shall be powered using a PELV power supply with 24V DC (+-15%)....	<b>FS1</b> (Use 24 VDC ±15% PELV power supply , → # 184)

ID (green=done for all FS)	Requirements	Realized (green=done for FSx)
WI-778	The drive shall be used for the following times: Mission Time: == 20 years Proof test interval > 20 years	<b>FS1</b> (The systematic capability according to IEC 61508 for the safety-related subsystems of the drive are SC = 2. TM = 20 Years, SFF = 75%., → # 183), (You must test the STO function after initial start of the axis, after each intervention into the wiring of the system, or after exchange of one or several components of the drive system. The proof test interval is one year to meet the required PFH., → # 183)
WI-802	The drive and its components shall meet the following environmental conditions: Storage condition: Humidity..... Transportation condition: Humidity....	<b>FS1/2/3</b> (Enclosure, wiring, → # 182)
WI-805	The drive shall be usable in environments with a pollution of degree 2 with non conductive material (according to EN 60664-1)	<b>FS1/2/3</b> (Pollution level 2 as per IEC 60664-1, → # 182)
WI-834	The safety manual shall require the safety functions to be validated during installation.	<b>FS1</b> (Check and verify the STO wiring (examples (→ # 185)). The installation must be verified by trained personnel after any changes to the installation. The expertise of the personnel must be appropriate to the complexity and safety integrity level of the drive system., → # 183)
WI-1186	The housing of the drive shall conform the IP 20 as per IEC 60664-1. The user manual shall require the drive to be placed in an IP54 cabinet.	<b>FS1/2/3</b> (Enclosure, wiring, → # 182)
WI-1373	The user manual shall require the user to - avoid shocks while transport - transport the device only in the manufacturers packaging	<b>FS1/2/3</b> (Enclosure, wiring, → # 182)
WI-1739	The help function shall be part of the certification and handled as part of the safety manual.	<b>FS1/2/3</b> , single source, the Installation Manual with Chapter10= Safety Manual is 100% part of the WorkBench Help. All SMM SafeGrid help aliases refer to Chapter 10 (Safety Manual) topics.
WI-2174	There shall be a notice in the safety manual, that even during STO there is the possibility of high voltages on the power stage and motor terminals. If there is work on the power terminals of the drive or the motor, the main power switch of the electrical installation shall be switched "off" to ensure high voltages do not occur on these lines.	<b>FS1/2/3</b> (Risk of electrical shock! The safety functions do not provide an electrical separation from the power output. If manual access to the motor or drive power terminals is necessary, , → # 180)
WI-2757	The wiring of the digital inputs shall be done such, that short circuits between the two channels of a single input are avoided.	<b>FS1/2/3</b> (When wiring the digital inputs and outputs, take care that short circuits between the inputs, outputs, or to supply lines are avoided., → # 182)
WI-2761	The display content and the usage of the push button shall be described in the safety manual. The user shall get an expectation of the behavior of the HMI before use.	<b>FS1/2/3</b> (Settings , → # 189)
WI-2806	Parameterizing of the SMM shall be done by trained personnel only. The level of experience shall be appropriate to the complexity and safety integrity level of the drive system.	<b>FS1/2/3</b> (Parameterizing Functional Safety: only by trained personnel with expertise appropriate to the complexity and safety integrity level of the drive system., → # 180)

ID (green=done for all FS)	Requirements	Realized (green=done for FSx)
WI-3632, WI-3630	The drive must not be connected to the Internet. The machine operator shall analyze whether further security requirements are applicable.	FS1 (The network the drive is connected to must be secured according to state-of-the-art information technology security requirements., → # 181)

## 14.2 IEC 61508-2 Annex D Requirements to User Documentation

ID (green=done for all FS)	Requirements	Realized (green=done for FSx)
61508-31a	Functional specification of the functions capable of being performed	<b>FS1:</b> (Available Safety Functions, → # 183)
61508-31b	Identification of the hardware and/or software configuration of the compliant item to enable configuration management of the E/e/PE safety-related system in accordance with 6.2.1 of IEC 61508-1	<b>FS1:</b> (Safety Manual for FS1, → # 179)
61508-31c	Constraints on the use of the compliant item and/or assumptions on which analysis of the behaviour or failure rates of the item are based	<b>Use</b> (Use as directed, → # 181) <b>Prohibited</b> (Prohibited use, → # 181) <b>Environment</b> (Enclosure, wiring, → # 182)
61508-32h	Any periodic proof test and/or maintenance requirements.	<b>FS1: STO</b> (Diagnostic test, → # 183)
61508-32i	For those failure modes, in respect of a specified function, that are capable of <b>being detected by external diagnostics</b> , sufficient information shall be provided to facilitate the development of an external diagnostics capability. The information shall include details of failure modes and for those failure modes the failure rates.	<b>FS1: STO</b> (Safety Faults, Safety Warnings, → # 190)
61508-32j	The hardware fault tolerance.	<b>FS1:</b> (The hardware fault tolerance is HFT = 1 according to IEC 61508. Two faults might lead to loss of the safety functions., → # 183)
61508-32k	The classification as type A or type B of that part of the compliant item that provides the function (see /1/ 7.4.4.1.2 and 7.4.4.1.3)	<b>FS1:</b> STO (STO is suited for SIL 2 according to IEC 62061 and PLd / Cat.3 according to ISO 13849-1. STO is a type A subsystem according to IEC 61508., → # 185)
61508-33a	The systematic capability of the compliant item or that part of the element that provides the function.	<b>FS1:</b> (The systematic capability according to IEC 61508 for the safety-related subsystems of the drive are SC = 2. TM = 20 Years, SFF = 75%., → # 183)
61508-33b	Any instructions or constraints relating to the application of the compliant item, relevant to the function, that should be observed in order to prevent systematic failures of the compliant item.	<b>FS1/2/3:</b> Full Installation Manual including Safety Manual.

### 14.3 ISO 13849-1, clause 11, Requirements to User Documentation

ID (green=done for all FS)	Requirements	Realized (green=done for FSx)
13849-1	— the limits of the safety-related parts to the category(ies) selected and any fault exclusions;	No fault exclusion
—	— the limits of the SRP/CS and any fault exclusions (see 7.3), for which, when essential for maintaining the selected category or categories and safety performance, appropriate information (e.g. for modification, maintenance and repair) shall be given to ensure the continued justification of the fault exclusion(s);	Fault exclusions not implemented
—	— the effects of deviations from the specified performance on the safety function(s);	No deviation
13849-2	— clear descriptions of the interfaces to the SRP/CS and protective devices;	Safe I/Os: FS1 (I/O hardware data, → # 184)
13849-3	— response time;	FS1 (Safety Properties Overview, → # 183)
13849-4	— operating limits (including environmental conditions);	FS1/2/3 (Use as directed, → # 181) FS1/2/3 (Prohibited use, → # 181) FS1/2/3 (Enclosure, wiring, → # 182)
13849-5	— indications and alarms;	FS1/2/3 (Safety Faults, Safety Warnings, → # 190)
13849-6	— muting and suspension of safety functions;	FS1/2/3 (Safety Faults, Safety Warnings, → # 190)
13849-8	— maintenance (see Clause 9);	FS1/2/3 (The device does not require maintenance. Opening the device voids the warranty. In case of damage or malfunction, the drive must be sent for repair or replacement if it cannot be repaired., → # 181)
13849-9	— maintenance check lists;	FS1/2/3 (The device does not require maintenance. Opening the device voids the warranty. In case of damage or malfunction, the drive must be sent for repair or replacement if it cannot be repaired., → # 181)
13849-10	— ease of accessibility and replacing of internal parts;	FS1/2/3 (The device does not require maintenance. Opening the device voids the warranty. In case of damage or malfunction, the drive must be sent for repair or replacement if it cannot be repaired., → # 181)
13849-11	— means for easy and safe trouble shooting;	FS1 (Troubleshooting Functional Safety, → # 191)
13849-12	— information explaining the applications for use relevant to the category to which reference is made;	FS1/2/3 (Resulting Functional Safety classification (SIL and/or PL level) is calculated across the drive system. The drive system usually consists of the following:, → # 180)

ID (green=done for all FS)	Requirements	Realized (green=done for FSx)
13849-13	— checking test intervals where relevant.	<b>FS1</b> (You must test the STO function after initial start of the axis, after each intervention into the wiring of the system, or after exchange of one or several components of the drive system. The proof test interval is one year to meet the required PFH., → # 183)
13849-14	— dated reference to this part of ISO 13849 (i.e. "ISO 13849-1:2006");	<b>FS1</b> (Standards, → # 183)
13849-15	— the Category, B, 1, 2, 3, 4;	<b>FS1</b> (Safety Properties Overview, → # 183)
13849-16	— the performance level, a,b,c,d,e.	<b>FS1</b> (Safety Properties Overview, → # 183)

#### 14.4 IEC 61508-3 Annex D Requirements to User Documentation

Not applicable, because the SMM software will not be identified as element which is sold separately. The SMM software will always be distributed as part of FS2 or FS3.

#### 14.5 Revisions

Revision	Remarks
1.0	First edition
1.1	ISO 13849 and EN 61508 requirements added
1.2	14.1/2/3: Table Header: green marking explained 14.3: Column "Planned Content" removed. 14: Additional WIs added/updated referring to "9D00-0657_Map Safety Traceability report Kollmorgen" table. 14.1 WI numbers sorted.
1.3	14.1 WI-1373 added 14.1 WI-231 etc: altitude 2000 m 14.3 Fault exclusion and deviation entries added (from Map Safety Manual Plan 9D00-0620)
1.4	WI-834 / WI-1752 separate lines WI-805 / WI-849 / WI-6536 added formal improvements WI-194 / WI-195 / WI-802 added