



*SP SERIES*

---

*INSTALLATION AND SETUP MANUAL*

Old Number    M97001 - ISSUE 1

**New Number    MSP000H**



**RECORD OF REVISIONS****( INSTALLATION AND SETUP MANUAL M97001 )**

ISSUE NO. (Revision)	DATE	CHANGED PAGES/BRIEF DESCRIPTION OF CHANGE	CHANGE NO.
0	6/11/97	Original Release Issue	
1	1/26/98	Incorporate Update Review Comments	

:

# **TABLE OF CONTENTS**

RECORD OF REVISIONS .....	A
TABLE OF CONTENTS	
Contents .....	i - iii
List of Figures .....	iv
List of Tables .....	v
List of Drawings.....	vi
INTRODUCTION	
How To Use This Manual.....	i-1
Installation and Start-up Guidelines .....	i-2
Customer Response.....	i-3
Copyright Information .....	i-4
European Community (EC) Declaration of Conformity.....	i-5
Abbreviations.....	i-6
<b>SECTION 1 SYSTEM DESCRIPTION</b>	
1.1 Introduction.....	1-1
1.2 Features.....	1-1
1.3 Theory of Operation.....	1-2
1.3.1 Power Supply Module.....	1-2
1.3.2 SERVOSTAR SP Drive Module .....	1-2
1.3.3 Brushless DC Motor .....	1-3
1.3.4 Power Up/Down Sequencing .....	1-3
1.4 Typical System Diagram.....	1-4
1.5 Signal Information .....	1-4
1.5.1 Current Feedback Signals .....	1-4
1.5.2 PWM Input Command Signals .....	1-4
1.5.3 Analog Input Signals.....	1-5
1.5.4 Six-step Commutation.....	1-5
1.6 Current Ratings and Duty Cycles.....	1-5
<b>SECTION 2 INSTALLATION</b>	
2.1 Introduction.....	2-1
2.2 Safety Information .....	2-1
2.3 Conventions .....	2-2
2.3.1 Model Numbering Scheme .....	2-2
2.3.2 Abbreviations.....	2-2
2.4 Unpacking and Inspection.....	2-2
2.5 Installation Requirements.....	2-3
2.5.1 Environmental Requirements .....	2-3
2.5.2 Enclosures.....	2-3
2.6 Assembly.....	2-3
2.6.1 Mounting.....	2-3
2.6.2 Mounting the External Regeneration Resistor(s) .....	2-4
<b>SECTION 2 INSTALLATION (CONTINUED)</b>	

2.7 Electrical Connections..... 2-4

2.7.1 Recommended Torque for Electrical Connections ..... 2-5

2.7.2 Grounding Scheme ..... 2-6

2.7.3 Connecting the AC Input Voltage ..... 2-6

2.7.4 Connecting the Main DC Bus Voltage ..... 2-6

2.7.5 Connecting the External Regeneration Resistor(s) ..... 2-7

2.7.6 Connecting the Unregulated DC Voltage to the SERVOSTAR SP Series Drive  
(Connector C5)..... 2-7

2.7.7 Connecting the SERVOSTAR SP Series Drive Analog Input / Output  
(Connector C2)..... 2-8

2.7.8 Connecting the SERVOSTAR SP Series Drive Digital Input / Output  
(Connector C3)..... 2-9

2.7.9 Connecting the SERVOSTAR SP2 Series Drive Digital Input / Output  
(Connector C1)..... 2-11

2.7.10 Connecting the Motor..... 2-12

2.8 Installation Checklist..... 2-13

2.8.1 Checking the Motor Wiring ..... 2-13

2.8.2 Checking the AC Line Voltages ..... 2-13

2.8.3 Checking the DC Bus Voltages ..... 2-13

**SECTION 3 OPERATION**

3.1 Introduction..... 3-1

3.2 Initial Start-up ..... 3-1

3.3 Sequence of Operations..... 3-1

**SECTION 4 MAINTENANCE**

4.1 Introduction..... 4-1

4.2 Preventative Maintenance ..... 4-1

4.2.1 Transient Voltages ..... 4-1

4.2.2 Surge Current ..... 4-2

4.2.3 Electrical Noise ..... 4-2

4.2.4 Radio Frequency Energy` ..... 4-2

4.3 Periodic Maintenance..... 4-3

4.3.1 Ventilation..... 4-3

4.3.2 Grounding Integrity..... 4-3

**SECTION 5 TROUBLESHOOTING**

5.1 Introduction..... 5-1

5.2 Field Serviceability ..... 5-1

5.3 Symptoms and Corrections..... 5-2

5.3.1 The Motor Exhibits Very Low Torque or is Totally Inoperative ..... 5-2

5.3.2 The Motor is Erratic or Exhibits an Improper Mode of Operation..... 5-2

5.3.3 SERVOSTAR SP Series Drive Status LED's ..... 5-2

5.3.4 Power Supply Amp Status LED's..... 5-3

5.3.5 SERVOSTAR SP Series Drive or Power Supply Reset Procedures..... 5-3

**APPENDIX A. WARRANTY INFORMATION**

APPENDIX B. REGIONAL SALES OFFICES

APPENDIX C. MODEL NUMBERS

APPENDIX D. CONNECTOR KITS & TOOLS

APPENDIX E. SPECIFICATIONS

APPENDIX F. OPTIONS

APPENDIX G. CURRENT LOOP COMPENSATION

APPENDIX H. DRAWINGS

GLOSSARY

INDEX

## LIST OF FIGURES

<u>Figure</u> -- <u>Title</u>	<u>Page</u>
1.1 -- Typical System Diagram.....	1-4
2.1 -- Connector, SERVOSTAR SP Series Drive (C5) & Power Supply .....	2-7
2.2 -- SERVOSTAR SP Series Drive Connector (C2).....	2-8
2.3 -- SERVOSTAR SP Series Drive Connector (C3).....	2-9
2.4 -- Enable and Reset .....	2-11
2.5 -- Motor Connections .....	2-12

## LIST OF TABLES

<u>Table</u> -- <u>Title</u>	<u>Page</u>
5-1 -- SERVOSTAR SP Series Drive Status LED Indicator Troubleshooting .....	5-4
5-2 -- Power Supply Status LED Indicator Troubleshooting .....	5-4

## LIST OF DRAWINGS

<u>Drawing</u>	<u>Page</u>
SERVOSTAR SP Series 3 & 6 Amp Drive Outline and Dimension Drawing.....	H-3
SERVOSTAR SP Series 10 Amp Drive Outline and Dimension Drawing.....	H-4
SERVOSTAR SP Series 20 Amp Drive Outline and Dimension Drawing.....	H-5
SERVOSTAR SP Series 30 Amp Drive Outline and Dimension Drawing.....	H-6
SERVOSTAR SP Series 55 Amp Drive Outline and Dimension Drawing.....	H-7
Power Supply PA08xx Outline and Dimension Drawing.....	H-8
Power Supply PA14xx and PA28xx Outline and Dimension Drawing.....	H-9
Power Supplies PA50xx, PA75xx, and PA85xx Outline and Dimension Drawing.....	H-10
Power Supply PA08xx Simplified Schematic Diagram.....	H-11
Power Supplies PA14xx and PA28xx Simplified Schematic Diagram.....	H-12
Power Supplies PA50xx, PA75xx, and PA85xx Simplified Schematic Diagram.....	H-13
SP1XXXX Simplified Schematic Diagram.....	H-14
SERVOSTAR SP Series System Wiring -- (Dwg. No. C-97514 - 11 Sheets).....	H-15

## **INTRODUCTION**

### **HOW TO USE THIS MANUAL**

This Installation and Setup Manual is designed to help you properly install a **SERVOSTAR SP Series Drive System**. You do not have to be an expert in motion control to operate the system, however, this manual does assume you have a fundamental understanding of basic electronics and motion control concepts and safety.

An understanding of computer operation techniques will be beneficial to most users, however, this product is designed to be used without prior computer knowledge.

It is recommended that you read this ENTIRE manual before you attempt to install the **SERVOSTAR SP Series Drive**. This will familiarize you with the system components and their relationship to one another.

After installation check all system parameters to insure you have configured your **SERVOSTAR SP** system properly.

Be sure to follow all instructions carefully and pay special attention to safety.

## **INSTALLATION AND START-UP GUIDELINES**

In order to ensure proper operation of the SERVOSTAR SP system, it is recommended that the installation and setup information in this manual be read and followed while mounting and wiring the unit. Failure to follow warnings, cautions, notes, and recommendations may affect system performance, safety, and may void the product warranty.

REFER TO THE FOLLOWING SECTIONS TO ENSURE PROPER INSTALLATION OF THE SERVOSTAR SP SERIES DRIVE:

Section 1. System Description

Section 2. Installation

Appendix E Specifications

Appendix H Drawings

THANK YOU!



Thank you and congratulations for choosing Industrial Drives' servo products for your motion control requirements. We seek to provide our customers with quality products, excellent support and outstanding value. In an effort to provide you with dependable and useful documentation, we offer you an opportunity to critique this manual with your comments and suggestions. Your feedback on this reader comments form is very important to us. Please answer the questions below and return the form to:

**INDUSTRIAL DRIVES - Technical Manual Department**

201 Rock Road  
 Radford, VA 24141  
 U.S.A.  
 FAX: 540/731/0847

Name: \_\_\_\_\_ Title: \_\_\_\_\_  
 Company: \_\_\_\_\_  
 Street Address: \_\_\_\_\_  
 City: \_\_\_\_\_ State: \_\_\_\_\_ Zip: \_\_\_\_\_  
 Telephone: \_\_\_\_\_ Fax: \_\_\_\_\_  
 Product: \_\_\_\_\_  
 Manual Part Number: \_\_\_\_\_

Please check the rating that best represents your opinion on each topic.

		Excellent	Good	Fair	Poor
1.	Overall clarity and readability.	<input type="checkbox"/>	<input type="checkbox"/>	<input type="checkbox"/>	<input type="checkbox"/>
2.	Organization of the manual.	<input type="checkbox"/>	<input type="checkbox"/>	<input type="checkbox"/>	<input type="checkbox"/>
3.	Information completeness.	<input type="checkbox"/>	<input type="checkbox"/>	<input type="checkbox"/>	<input type="checkbox"/>
4.	Information accuracy.	<input type="checkbox"/>	<input type="checkbox"/>	<input type="checkbox"/>	<input type="checkbox"/>
5.	Installation procedures.	<input type="checkbox"/>	<input type="checkbox"/>	<input type="checkbox"/>	<input type="checkbox"/>
6.	Ability to quickly find information you need.	<input type="checkbox"/>	<input type="checkbox"/>	<input type="checkbox"/>	<input type="checkbox"/>
7.	Graphics.	<input type="checkbox"/>	<input type="checkbox"/>	<input type="checkbox"/>	<input type="checkbox"/>
8.	Figures (usefulness).	<input type="checkbox"/>	<input type="checkbox"/>	<input type="checkbox"/>	<input type="checkbox"/>
9.	Tables (usefulness).	<input type="checkbox"/>	<input type="checkbox"/>	<input type="checkbox"/>	<input type="checkbox"/>
10.	Overall rating of this manual.	<input type="checkbox"/>	<input type="checkbox"/>	<input type="checkbox"/>	<input type="checkbox"/>

Please list any errors. \_\_\_\_\_  
 \_\_\_\_\_

What did you like least about this manual? \_\_\_\_\_  
 \_\_\_\_\_

What did you like most about this manual? \_\_\_\_\_  
 \_\_\_\_\_

How would you improve this manual? \_\_\_\_\_  
 \_\_\_\_\_

Signature: \_\_\_\_\_ Date: \_\_\_\_\_

**COPYRIGHT INFORMATION**

© Copyright 1997, Industrial Drives, A Kollmorgen Division. All rights reserved.

Printed in the United States of America.

**NOTICE:**

Not for use or disclosure outside of Industrial Drives except under written agreement.

All rights reserved. No part of this book shall be reproduced, stored in a retrieval system, or transmitted by any means, electronic, mechanical, photocopying, recording, or otherwise without the written permission from the publisher. While every precaution has been taken in the preparation of the book, the publisher assumes no responsibility for errors or omissions. Neither is any liability assumed for damages resulting from the use of the information contained herein.

This document is proprietary information of Industrial Drives, A Kollmorgen Division, furnished for customer use ONLY. No other uses are authorized without written permission of Industrial Drives.

Information in this document is subject to change without notice and does not represent a commitment on the part of Industrial Drives or the Kollmorgen Corporation. Therefore, information contained in this manual may be updated from time-to-time due to product improvements, etc., and may not conform in every respect to former issues.

IBM-PC is a trademark of International Business Machines Corporation.

U.L. is a trademark of Underwriters Laboratories.

N.E.C. is a trademark of the National Electric Code.

GOLDLINE, BDS4, BDS5, PSR4/5, Motion Link, PC-Scope, and Macro Moves are trademarks of the Kollmorgen Corporation.

**WARNING**

**Dangerous voltages, currents, temperatures, and energy levels exist in this product and in the associated servo motor(s). Extreme caution should be exercised in the application of this equipment. Only qualified individuals should attempt to install, set-up, and operate this equipment. Ensure that the motor, drive, and the end-user assembly are all properly grounded per NEC requirements.**

**KOLLMORGEN**  
**Motion Technologies Group**

**INDUSTRIAL DRIVES**  
201 Rock Road  
Radford, VA 24141  
Phone: 540/639/2495  
Fax: 540/731/0847

## **EUROPEAN COMMUNITY (EC) DECLARATION OF CONFORMITY**

We, Kollmorgen Corporation Industrial Drives Division, 201 Rock Rd, Radford, VA, USA, declare: under sole responsibility, this equipment is exclusively designed for incorporation in another machine. The operation of this equipment is submitted to the conformity of the machine in which it is incorporated, following the provisions of the EC Electro-Magnetic Compatibility (EMC) directive 89/392/EEC.

## **ABBREVIATIONS**

A/D	Analog-to-Digital Converter
CCW	Counter Clockwise*
CMR	Common Mode Rejection
CNC	Computer Numerical Control
Cont.	Continued
CW	Clockwise*
CR-LF	ASCII Carriage Return, Line Feed
D/A	Digital-to-Analog Converter
D/L	Direction Limit
EMF	Electro-Motive Force
EMI	Electro-Magnetic Interference
ESD	Electrostatic Discharge
GC	Goldline Cable
GCS	Goldline Cable Set
Hz	Hertz
I	Current
I/O	Input / Output
kHz	KiloHertz
KMTG	Kollmorgen Motion Technologies Group
KW	KiloWatts
LED	Light Emitting Diode
NEC	National Electrical Code
PC	Personal Computer
P/N	Part Number
PK	Peak
PLC	Programmable Logic Control
PWM	Pulse Width Modulation
R/D	Resolver-to-Digital
Regen	Regeneration
RMS	Root Mean Square
Tach	Tachometer
TL	Test Limits
UL	Underwriters Laboratories

\* Clockwise and counterclockwise reference as viewing the motor output shaft.

# SECTION 1

## SYSTEM DESCRIPTION

### 1.1 INTRODUCTION

Kollmorgen Motion Technology Group's (KMTG) **SERVOSTAR SP Series** product line consists of a series of smart power stages and power supplies. They are fully regenerative four-quadrant, bi-directional PWM amplifiers designed to be used with KMTG's high performance permanent magnet brushless motors or other three phase motors or loads. The product is an intelligent switching power amplifier used in high-power servo systems. The SP1 Series of **SERVOSTAR SP Series Drives** has three different modes of operation:

1. Direct Transistor Control.
2. Two Phase Analog Current Command Input
3. Current Command Input - Six Step Motor Excitation

The **SERVOSTAR SP Series Drive** modules are available in ratings of 3, 6, 10, 20, 30, and 55 amps RMS/phase continuous output power. The modular design provides the flexibility for multiple axis to share a common power supply. The power supplies require no input isolation transformer.

The **SERVOSTAR Power Supply** modules are available in sizes of Logic-only, 8, 14, 28, 50, 75, and 85 amps RMS/phase continuous (AC input line ratings).

The **SERVOSTAR SP Series** product line rates all currents as RMS values for sine wave control.

### 1.2 FEATURES

Highlighted design features include:

- Modular construction maximizing serviceability and economy.
- Two piece plug connectors interfacing.
- High frequency (up to 32 kHz) motor current ripple for quality servo performance, higher efficiency, and less audible noise.
- Differential analog inputs (Modes 2 & 3).
- Extensive protection features including: Main power bus over-volts shutdown, main power bus under-volts lock-out, peak over-current shut-down, short circuit and over-temp shutdown, logic bus under-volts shut-down, and PWM frequency limiting circuitry.
- Status Indicator: Solid State Relay turns on indicating the amplifier is ready for input command signal; opens on fault conditions.
- Power Supply units contain a Soft Start function for direct line connection.
- The 14 and 28 amp Power Supply unit includes 40 watts of internal shunt regulation. The 28, 50, 75 and 85 Amp Power Supplies have external shunt regulator resistor options.
- Diagnostic LED indicators located on the front panel on both the **SERVOSTAR SP Series Drives** and the Power Supply modules.

## 1.3 THEORY OF OPERATION

The SERVOSTAR SP Series system consists of five main components:

1. Power Supply Module
2. SERVOSTAR SP Series Drive Module
3. Brushless Motor
4. User Control System
5. Interconnecting Cables

### 1.3.1 Power Supply Module

The Power Supply Module is divided into four (4) main sections:

1. The Unregulated Logic Bus, derived from the Control AC line input voltage, is described in Section 4.2.
2. The 325/160 Volt Main DC Bus (nominal) is supplied by the main AC line input voltage (normally three-phase 230 VAC or single-phase 115 VAC).
3. The Soft-Start Feature circuitry limits the in-rush current (to charge the Main Bus Capacitors) to a specific amount as listed in Appendix E.
4. The Shunt Regulator (regeneration) section includes circuitry which monitors the main bus. During deceleration profiles, the motor operates as a DC generator and pumps energy back into the main bus causing the bus voltage to rise. This action is referred to as regeneration (regen). The Shunt Regulator limits the voltage rise during the deceleration periods by dumping excess energy into the shut resistor.

### 1.3.2 SERVOSTAR SP Drive Module

The SERVOSTAR SP Drive Module is divided into four (4) main sections:

1. Fault Diagnostics circuitry which monitors various signals. When a fault condition occurs the fault circuit will become latched, the SP will become internally inhibited, the appropriate red LED will become illuminated, and the fault output will open indicating that the SERVOSTAR SP Series Drive is in its Inhibit mode. A toggle on the reset input will attempt to reset the latch.
2. The Input / Output interface circuitry is divided into two functions:
  - (A) Signals between the load and the SERVOSTAR SP Series Drive.
  - (B) Signals between the signal source (PLC, CNC, etc.) and SERVOSTAR SP Series Drive. There are numerous signals that may be used to interface between the signal source (PLC, CNC, etc.) and the SERVOSTAR SP Series Drive. These inputs and modes of operation differ with each application.
3. When the external current loop mode is selected (Mode 1), the command signals are via the three sets of differential inputs. Current feedback outputs for "A" phase and "C" phase leads are supplied for externally closing the current loops. When the current loops are external to the unit there is no control on the PWM frequency and as a result, no control of switching losses. To use the unit in the external current loop mode, DO NOT install the header at location "COMP".
4. When the internal current loop mode is selected (Mode 2), the command signals are input via the two differential analog inputs (for two out of the three phase current command). Internal circuitry processes these signals to generate current in a load using internal analog proportional plus integral current loops with 10 kHz PWM. To use the unit in the internal current loop mode, the header with the current loop compensation components must be installed on the unit (at location "COMP" ) because the jumper between Pins 1 and 16 sets the unit for this mode of operation.

5. When the six-step mode is selected (Mode 3), one of the differential analog inputs is used as a current command input and the PWM inputs of Mode 1 are used as the commutation (Hall sensor) inputs. Internal circuitry processes these signals to generate motor current using internal analog proportional plus integral current loop with 10 kHz PWM and does the commutation sequencing. To use the unit in the six-step mode, the header with the current loop compensation components must be installed on the unit (at location "COMP"). A jumpers between Pins 1 and 16 and the jumper between Pins 2 and 15 set the unit for this mode of operation

### 1.3.3 Brushless DC Motor

The KMTG GoldLine B and M Series and SilverLine Series brushless motors feature the latest in permanent magnet technology, utilizing high energy Neodymium-Iron-Boron alloys. These brushless motors consist of permanent magnet rotors and three-phase Y-stator windings. This places the heat producing member on the outside where it can best dissipate heat. These motors (depending on size) are either four- or six-pole motors. Since they are brushless motors, there are no commutators or associated brushes. The motors run as synchronous motors, meaning the rotor speed is the same as the speed (frequency) of the stator's rotating magnetic field. The feedback device is typically a brushless resolver, mounted internally as part of the overall motor construction. Other available options include integral brush tachometers and encoders. For more information, refer to the Installation and Service Manual, B Series Brushless Motors M-89031.

### 1.3.4 Power Up/Down Sequencing

It is recommended that the control voltage be applied first and then apply the main AC voltage. Next, check for faults and then enable the SERVOSTAR SP Series Drive. Typical Power up sequence:

1. Only the Control AC line input voltage is applied.
  - a. The logic bus comes up.
  - b. A power-up reset pulse is generated in the SERVOSTAR SP Series Drive.
  - c. If no faults (other than main bus under-volts) are present after the power-up reset pulse is generated (a delay of  $\approx 0.6$  seconds) then the drive is ready to be enabled. However, there can be no load activation until the main AC line input voltage is applied.
2. The Main AC line input voltage is applied.
  - a. The soft-start circuit charges the Main DC bus capacitors in the Power Supply through a current limiting resistor and then this resistor is bypassed.
  - b. The under-voltage fault in the SERVOSTAR SP Series Drive is now cleared (after approximately 0.15 sec delay), and the fault output in the SERVOSTAR SP Series Drive will close. The drive is ready to be enabled and will enable once the enable input is activated.
3. Only the Main AC line input voltage is removed.
  - a. The main DC Bus will slowly discharge (less than 2 min. to below 50 VDC).
  - b. The fault contact within the SERVOSTAR SP Series Drive will open due to Bus under-volts when the bus drops to below about 110 VDC.
4. Only the Control AC line input voltage is removed.
  - a. The fault output contact in the SERVOSTAR SP Series Drive will open. The drive is immediately disabled.
  - b. The Power Supply fault contact will open.
5. It is recommended that the input commands be held at zero upon applying power. Power up delay is approximately 1 second.

The AC line input voltages may be removed in any sequence.

## 1.4 TYPICAL SYSTEM DIAGRAM

Figure 1.1 illustrates a typical system with all of the major components.

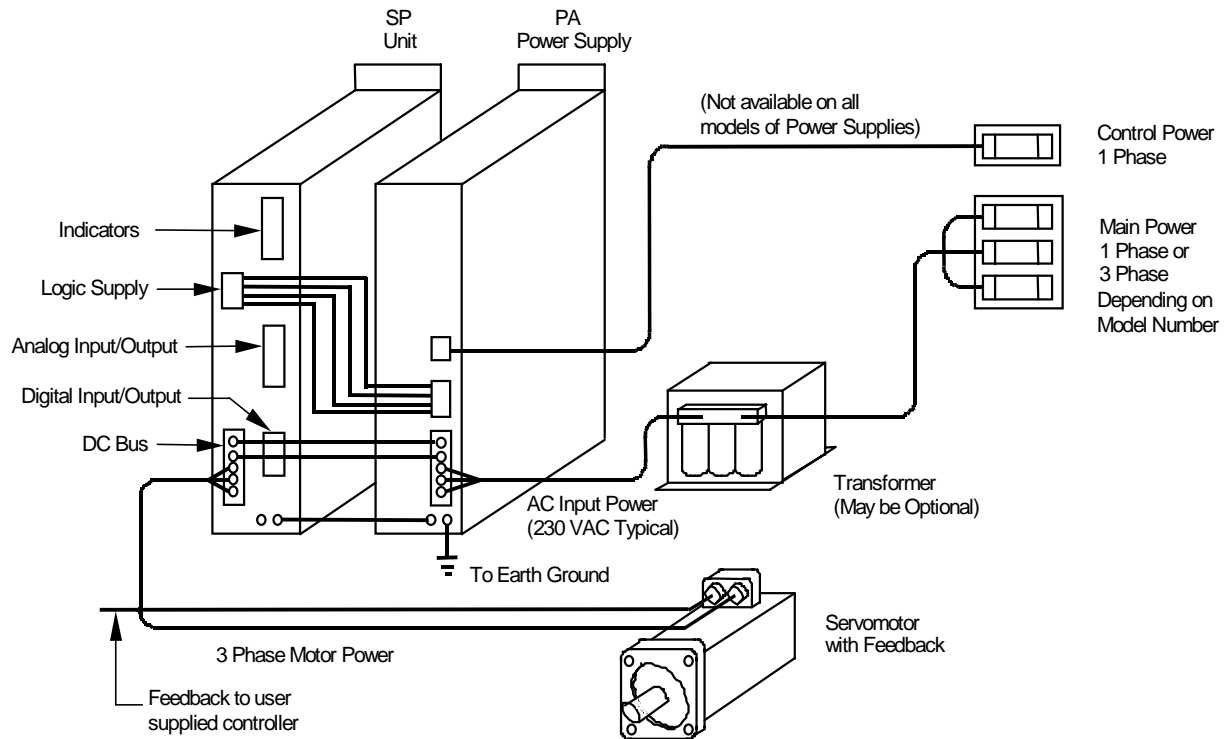

**Figure 1.1. Typical System Diagram**

## 1.5 SIGNAL INFORMATION

### 1.5.1 Current Feedback Signals

Polarity: positive voltage: current into drive, out of load

Magnitude (Maximum):

Sinewave commutation:  $(\sqrt{2}) \times (\text{unit's max. RMS rating}) = 8 \text{ volts (peak of sinewave)}$

Six-step commutation:  $(\text{unit's max. RMS rating}) \times (\sqrt{[3/2]}) = 7.93 \text{ volts (peak of six-step wave)}$

### 1.5.2. PWM Input Command Signals

Used in Mode 1 operation. High side positive with respect to low side: results in current out of unit into load (turns phase's top transistor on and bottom transistor off)

Low side positive with respect to high side: results in current out of load into unit (turns phase's top transistor off and bottom transistor on)

High side = low side: turn's phase's top and bottom transistors off

### 1.5.3 Analog Input Signals

Polarity: positive voltage: results in current into unit out of load

Magnitude (Maximum):

Mode 2 operation (sinewave commutation):  $(\sqrt{2}) \times (\text{unit's max. RMS rating}) = 10$  volts (peak of sinewave)

Mode 3 operation (six-step commutation):  $(\text{unit's max. RMS rating}) \times (\sqrt{3/2}) = 8.66$  volts (DC level)

Phasing (Mode 2 operation only): AC\_HI:AC\_LO leading CC\_HI:CC\_LO by 120° electrical results in clock-wise rotation (viewing motor's shaft end) for motors with ACB phasing (such as Kollmorgen's GoldLine motors).

### 1.5.4 Six-step Commutation

Commutation Signals Phasing Requirement: H1 leads H2 by 120° elect. which leads H3 by 120° elect with motor clock-wise rotation (viewing motor's shaft end).

Commutation Signals Alignment Requirement: H1 in phase with: motor's "A" phase with respect to "B" phase BEMF (with motor clock-wise rotation; viewing motor's shaft end). Motor's phasing to be ABC sequence (with motor clock-wise rotation; viewing motor's shaft end).

## 1.6 CURRENT RATINGS AND DUTY CYCLES

The continuous current rating of the SERVOSTAR SP Series Drive units is dependent on how hot the heatsink becomes. This can be a function of duty cycle and switching frequency. The unit is rated for operation in a 45 degree Celsius environment and 16 kHz switching for the 3, 6, and 10 Amp units and 8 kHz for the 20, 30, and 55 amp units.

The peak current rating of the SERVOSTAR SP Series Drive is twice its continuous rated current. This amount of time the peak current is allowed out of the SERVOSTAR SP Series Drive must be controlled to keep the power devices from overheating. The peak current should not be allowed for more than 6 seconds in a 30 second period. The RMS output current must not exceed the rated current of the SERVOSTAR SP Series Drive.



## SECTION 2

# INSTALLATION

### 2.1 INTRODUCTION

The information in this Section will familiarize you with the safety information, unpacking and inspection, installation requirements, assembly procedures and electrical connections for installing the SERVOSTAR SP Series Drive.

A checklist is provided at the end of this Section to insure proper installation.

### 2.2 SAFETY INFORMATION

The safety-alert symbols are illustrated as follows:



*Safety-Alert Symbols*

When you see these symbols in this manual, be alert to the potential for personal injury. Follow the recommended precautions and safe operating practices included with the alert symbols.

Safety notices in this manual provide important information. Read and be familiar with these instructions before attempting installation, operation, or maintenance. The purpose of this section is to alert users to possible safety hazards associated with this equipment and the precautions that need to be taken to reduce the risk of personal injury and damage to the equipment.

Failure to observe these precautions could result in serious bodily injury, damage to the equipment, or operational difficulty.

**"Warning"** alerts users to potential danger or harm. Failure to follow warning notices could result in personal injury or death.

**"Caution"** directs attention to general precautions, which if not followed, could result in personal injury and/or equipment damage.

**"Note"** highlights information critical to your understanding or use of these products.

## 2.3 CONVENTIONS

To assist you in understanding the material in this manual, conventions have been established to enhance reader comprehension. Explanations of these conventions are as follows:

- Safety warnings, cautions, and notes present material that is important to user safety. Be sure to read any safety notices you see as they could prevent equipment damage, personal injury, or even death to you or a co-worker.
- **Bold** text highlights other important information that is critical to system operations.
- **CAPITALIZED** text stresses attention to the details of the procedure.
- Underlined text emphasizes crucial words in sentences that could be misunderstood if the word is not recognized.

### 2.3.1 Model Numbering Scheme

All **SERVOSTAR** components contain a model and serial number printed on a tag on the side panel. The model number identifies how the equipment is configured. Refer to Appendix C for the model number scheme tables. These tables explain what the model configurations are. You should verify that the model numbers represent the equipment desired for your application. Also verify the compatibility between components of the servo system.

### 2.3.2 Abbreviations

CCW	Counter Clockwise
CW	Clockwise
DIFF CMD	Differential Command
D/L	Direction Limit
GC	GoldLine Cable
GCS	GoldLine Cable Set
KMTG	Kollmorgen Motion Technologies Group
LED	Light Emitting Diode
NEC	National Electrical Code
P/N	Part Number
R/D	Resolver-to-Digital
Regen	Regeneration
TL	Test Limits
UL	Underwriters Laboratories

## 2.4 UNPACKING AND INSPECTION

---

**Electronic components in this amplifier are static sensitive. Use proper procedures when handling component boards.**

---

Upon receipt of the equipment, closely inspect components to ensure that no damage has occurred in shipment. If damage is detected, notify the carrier immediately.

Carefully remove packing material and remove the equipment from the shipping container. Do not dispose of shipping materials until the packing list has been checked. Parts that are contained within the shipment, but not

physically attached to the equipment, should be verified against the packing list. If any parts are missing, notify Industrial Drives at once.

## 2.5 INSTALLATION REQUIREMENTS

Proper installation and field wiring are of prime importance when considering the application of servo amplifiers. Many problems may be avoided if installation of the equipment is done properly. Users should familiarize themselves with and follow installation and wiring instruction in addition to all applicable codes, laws and standards. Pay special attention to the following topics when installing Industrial Drives' equipment.

### 2.5.1 Environmental Considerations

The environment that this equipment is placed in can have dramatic effects on its operation. Industrial Drives recommends that the SERVOSTAR SP Series Drive and Power Supply be operated and stored under the following conditions:

- Operating Temperature: 0° C to 45° C
- Storage Temperature: -20° C to 70° C
- Humidity: 10% to 90% (Non Condensing)

### 2.5.2 Enclosures

It is suggested that the SERVOSTAR SP Series Drive and Power Supply be mounted in a cabinet or other suitable enclosure to protect them from physical and environmental damage. Refer to Appendix E for complete system dimensions.

---

**Allow sufficient clearance for the large "regenerative" heat producing resistor(s) mounted at the upper edge of the Power Supply unit and the externally mounted regen (shunt regulator) power resistor(s).**

---

## 2.6 ASSEMBLY

The SERVOSTAR SP Series Drive and Power Supply are both constructed prior to shipping from the factory. The only assembly required is the mounting of the devices. Operation in Modes 2 or 3 may require addition of the 'COMP' header.

### 2.6.1 Mounting

Refer to the drawing of your model system in Appendix H for outline and dimensions. Be sure to look at the proper drawing for mounting measurements.

The Power Supply and SERVOSTAR SP Series Drive modules should be mounted in the vertical position.

Depending on the continuous current ratings of the SERVOSTAR SP Series Drive and Power Supply modules, up to four units may be mounted with a single power supply.

---

**Refer to the drawing of your model system in Appendix H for the Mounting Hole Pattern information.**

---

---

**Allow sufficient clearance for the large "regenerative" heat producing resistor(s). The internal resistors are mounted at the upper edge of the Power Supply unit. The externally mounted regen (shunt regulator) power resistor(s) are mounted above the Power Supply unit.**

---

## 2.6.2 Mounting the External Regeneration Resistor(s)

---

**External regenerative resistors are a shock hazard!**

**Mount these resistors properly! Enclose these resistors to protect personnel and equipment!**

---

**External regeneration resistors can become extremely hot!**

**Allow safe clearance around the resistor(s) enclosures. Proper ventilation must be provided.**

---

If the application requires greater than 40 watts of regen (shunt regulation) on the PA28, or any regen on the PA50 and 75 then an externally mounted regen resistor is required. The resistor kit includes the resistor(s) and mounting hardware. A suitable enclosed location needs to be set aside for mounting these components while observing the heat and shock requirements of these resistors. The external regen resistor kit includes a thermal overload protection device that must be wired in series with the resistor. The contacts of the overload should be wired to drop power if they open.

## 2.7 ELECTRICAL CONNECTIONS

---

**Dangerous voltages, currents, temperatures, and energy levels exist in this product and in the associated servo motor(s). Extreme caution should be exercised in the application of this equipment. Only qualified individuals should attempt to install, set-up, and operate this equipment. Ensure that the motor, drive, and the end-user assembly are properly grounded per NEC requirements.**

---

To facilitate wiring, the SERVOSTAR SP Series Drive units must be mounted next to the PA power supply module in descending order according to their continuous current ratings.

Follow these precautions:

1. Observe all notes on the wiring diagram.

2. All motor stator leads, signal input leads, resolver leads and encoder leads must be shielded.
3. Twist all AC leads to minimize electromagnetic emissions (noise).
4. Avoid running signal leads (must be shielded) in close proximity to power leads, motor stator leads, or other sources of electromagnetic noise.
5. Minimize lead lengths as much as possible.
6. Connect the SERVOSTAR SP system according to the System Wiring Diagram; pay close attention to the grounding scheme.
7. Provide adequate stress relief for cables.

Thermal overload protection for the motor is not provided within the SERVOSTAR SP Series Drive and must be provided externally. Refer to the National Electrical Code for proper sizing of overload protection. Motor thermostat is often sufficient.

With the exception of the hook-up of the motor, the main input voltage, and the main Bus+ and Bus- DC voltage, all interface wiring between the SERVOSTAR SP Series Drive, Power Supply, and other equipment is accomplished by connectors supplied with the SERVOSTAR SP Series Drive and Power Supply units.

The input/output connections are grouped by connector or terminal block. They are input/output, motor, AC main power and control voltages, main DC bus, and unregulated DC voltages.

Captive screws are used in the power terminals of the PA08 module, PA28 module, and the 3 amp through the 20 amp SERVOSTAR SP Series Drive amplifiers. Do not attempt to remove these screws to use ring terminals. Use locking spring terminals similar to Hollingsworth #XSS20945S or #SS20947SF for 16 and 14 AWG wire and #XSS20836 or #SS20832F for 12 and 10 AWG wire.

### 2.7.1 Recommended Torque for Electrical Connections

Table 2.1 displays the recommended torque values for terminal block and grounding connecting points. All torques are measured with the wire or terminal lug underneath the screw head.

**Table 2.1. Torque Values**

Connecting Points	SPx03, 06, 10, 20 Amp Units	PA08, 28 Amp Units
AC Input Screws		12 in. lb.
DC Bus Screws	12 in. lb.	12 in. lb.
Motor Connecting Screws	12 in. lb.	
External Regen Screws		12 in. lb.
Ground Screws	12 in. lb.	12 in. lb.

## 2.7.2 Grounding Scheme

To prevent shock hazard to personnel and to ensure proper operation of the SERVOSTAR SP Series Drive system, the SERVOSTAR SP Series Drive, Power Supply, and the servo motor must be grounded properly. Each SERVOSTAR SP Series Drive and Power Supply have at least two grounding screws on the front of the chassis.

---

**Provisions of the National Electrical Code with respect to grounding should be followed. These precautions generally deal with the ground loop currents arising from multiple ground paths. Only one ground path should be used.**

---

One of the screws on the chassis of the Power Supply should go to earth (machine) ground. The other(s) should be connected to the SERVOSTAR SP Series Drive(s) ground screw. The ground wire from the motor and its cable shield should be connected to one of the ground screws for the associated SERVOSTAR SP Series Drive. The other ground screw on the SERVOSTAR SP Series Drive should be connected to a ground screw on the Power Supply unit.

For grounding to machine or earth ground, a screw lug should be attached to the ground screw on the Power Supply or SERVOSTAR SP Series Drive. A torque of 12 in.lb. for ground screws is recommended. Also refer to the National Electrical Code (NEC) or UL standard 486B for recommended torque's.

## 2.7.3 Connecting the AC Input Voltages

The three-phase main AC Input Voltage three-phase, should be connected at  $L_a$ ,  $L_b$ , and  $L_c$  on the power terminal block located on the front of the Power Supply unit.

The PA08 gets its' logic input from  $L_a$ , and  $L_b$ , so when using single phase power, the main AC input voltage should be connected at  $L_a$ , and  $L_b$ . The logic input is universal and needs no settings for operation at 115 V or 230 V.

The PA28, 50, and 75 have separate control AC input voltage connections on Connector C2 - Pins 3 and 6. and must be 220Vac. They are not designed for 115Vac logic supply operation.

## 2.7.4 Connecting the Main DC Bus Voltage

Refer to notes on the SERVOSTAR SP Series Drive Wiring Diagram for details concerning the hook-up of the Bus + and Bus - circuits between the Power Supply and the SERVOSTAR SP Series Drive units.

---

**Failure to observe correct polarity will result in damage to the Power Supply and SERVOSTAR SP Series Drive.**

---

## 2.7.5 Connecting the External Regeneration Resistor(s)

If an external regeneration resistor is required, connecting points are provided on the PA Power Supply Unit. Be certain that the overload relay is wired in series with the resistor and that the safety contacts are wired to prevent further operation should they open.

### 2.7.6 Connecting the Unregulated DC Voltage to the SERVOSTAR SP Series Drive (Connector C5)

The wiring between the SERVOSTAR SP Series Drive Connector C5 and the Power Supply Connector (unregulated voltage) is as follows:

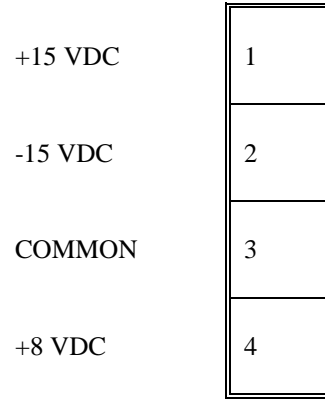

**Figure 2.1. Connector, SERVOSTAR SP Series Drive (C5) & Power Supply**

### 2.7.7

### 2.7.8 Connecting the SERVOSTAR SP1 Series Drive Analog Input / Output (Connector C2)

The pinouts are shown in Figure 2.2.

Ic	6	12	IC RTN
Ia	5	11	IA RTN
Shield	4	10	NC
Shield	3	9	Common
CC_HI	2	8	CC_LO
AC_HI	1	7	AC_LO

**Figure 2.2. SERVOSTAR SP Series Drive Connector (C2)**

- Pin 1 "AC\_HI" Opmode: 2, 3  
Differential high input command, "AC\_HI"; Mode 1 operation - not used; Mode 2 operation - "A phase" channel; Mode 3 operation - "command high input"
- Pin 7 "AC\_LO" Opmode: 2, 3  
Differential low input command, "AC\_LO"; Mode 1 operation - not used; Mode 2 operation - "/A phase" channel; Mode 3 operation- "command low input"
- Pin 3 Shield Opmode: 2, 3  
"A phase" input cable shield connection
- Pin 2 "CC\_HI" Opmode: 2  
Differential high input command, "CC\_HI"; Mode 1 operation - not used; Mode 2 operation - "C phase" channel; Mode 3 operation - not used
- Pin 8 "CC\_LO" Opmode: 2  
Differential low input command, "CC\_LO"; Mode 1 operation - not used; Mode 2 operation - "/C phase" channel; Mode 3 operation-not used
- Pin 4 Shield Opmode: 2  
"C phase" input cable shield connection
- Pin 5  $I_A$  Opmode: 1  
"A phase" current feedback signal; used with Mode 1 operation; available in other modes

- Pin 11  $I_A$  RTN Opmode: 1  
"A phase" current feedback signal return; used with Mode 1 operation; available in other modes
- Pin 6  $I_C$  Opmode: 1  
"C phase" current feedback signal; used with Mode 1 operation; available in other modes
- Pin 12  $I_C$  RTN Opmode: 1  
"C phase" current feedback signal return; used with Mode 1 operation.
- Pin 9 Common Opmode: All  
Circuit common
- Pin 10 Not Used  
No connection; not used

### 2.7.9 Connecting the SERVOSTAR SP1 Series Drive Digital Input / Output (Connector C3)

The following descriptions tell the user which inputs and modes of operation are available, enable the user to identify the appropriate connecting points on Connector C3, and help the user decide which inputs and modes of operation to use. The pinouts are shown in Figure 2.3.

FAULT LO	8	16	FAULT HI
ENABLE	7	15	RESET
24 V	6	14	5 V
C	5	13	
SHIELD	4	12	SHIELD
B	3	11	$\bar{B}$
SHIELD	2	10	SHIELD
A	1	9	$\bar{A}$

**Figure 2.3. SERVOSTAR SP Series Drive Connector (C3)**

- Pin 1 A Opmode: 1, 3  
Positive input of differential optically isolated input for A phase (motor) High.

- Pin 9  $\bar{A}$  Opmode: 1, 3  
Negative input of differential optically isolated input for A phase load (motor) Low.
- Pin 2 Shield Opmode: 1, 3  
"A" Phase input cable shield connection. The shield pins provide termination points for cable shields. To insure there are no ground loops in the shield common, connect only one end, butt and insulate the other end.
- Pin 3 B Opmode: 1, 3  
Positive input of differential optically isolated for B phase load (motor) High.
- Pin 11  $\bar{B}$  Opmode: 1, 3  
Negative input of differential optically isolated for B phase load (motor) Low.
- Pin 10 Shield Opmode: 1, 3  
"B" Phase input cable shield connection
- Pin 5 C Opmode: 1, 3  
Positive input of differential optically isolated for C phase load (motor) High.
- Pin 13  $\bar{C}$  Opmode: 1, 3  
Negative input of differential optically isolated for C phase load (motor) Low.
- Pin 4 Shield Opmode: 1, 3  
"C" Phase input cable shield connection
- Pin 6 24 V (Plus or Minus) Opmode: All  
Provides optocoupler signal common rail to 24 volts for systems choosing 24 V operation for the enable and reset inputs. This common rail can be connected to positive voltage (user sinks current) or to minus voltages (user sources current). When this input is used, Pin 14 must not be used.
- Pin 14 5 V (Plus or Minus) Opmode: All  
Provides optocoupler signal common rail to 5 volts for systems choosing 5 V operation for the enable and reset inputs. This common rail can be connected to positive voltage (user sinks current) or to minus voltages (user sources current). When this input is connected, Pin 6 must not be used.
- Pin 7 Enable Opmode: All  
Allows the SERVOSTAR SP Series Drive to be enabled or disabled without removing the main power. When a circuit is closed between Pin 7 and common (assuming Pin 6 is connected to +24 VDC or Pin 14 is connected to +5 VDC, see Figure 2.5), the SERVOSTAR SP Series Drive will be put into the Drive-Up mode. Opening the circuit puts the SERVOSTAR SP Series Drive into the Inhibit mode (Green LED indicated).
- Pin 15 Reset Opmode: All  
Allows any latched fault circuit except OVER-VOLTS or OVER-CORRECT faults to be reset by toggling Pin 15 to common (Assuming Pin 6 is connected to +24 VDC or Pin 14 is connected to +5 VDC). See Figure 2.4.

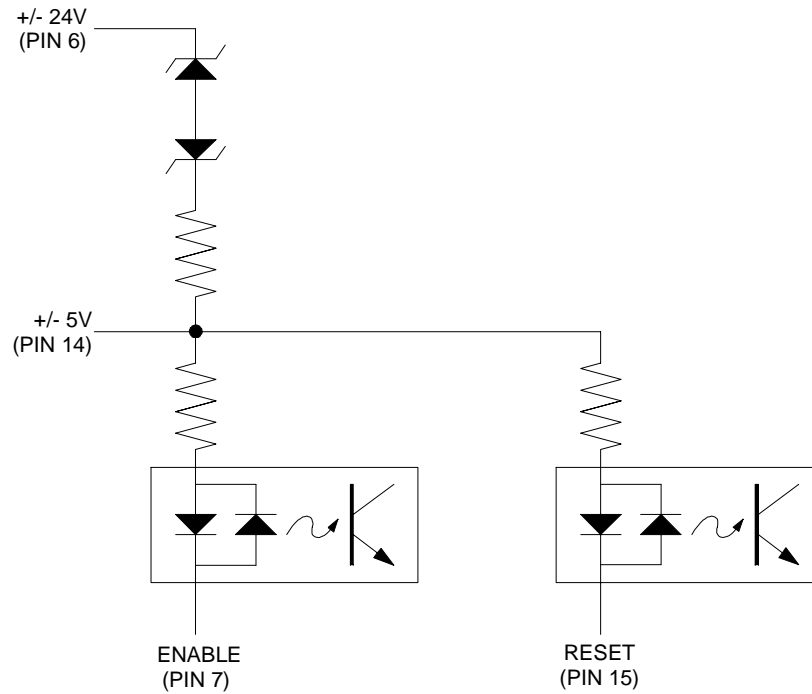

**Figure 2.4 Enable and Reset**

Pin 8 Fault Output Low Side Opmode: All  
Optically isolated fault output transistor's source.

The transistor is normally on, indicating that no fault conditions exist.

Pin 16 Fault Output High Side Opmode: All  
Optically isolated fault output transistor's drain

The transistor is normally on, indicating that no fault conditions exist.

Pin 12 Shield Opmode: 1, 3

Provided for connection of cable shields if necessary. Best shielding may result by connection at the other (source) end.

### 2.7.10 Connecting the Servostar SP2 Series Drive Digital Input/Output (Connector C1)

See System Wiring Diagram C-97514 sheet 4 of 11 in Appendix H Drawings.

### 2.7.11 Connecting the Motor

---

B SERIES MOTORS have a thermostat switch wired to the resolver connector at the motor.

BR SERIES MOTORS have a thermostat switch wired to the stator connector at the motor.

---

The motor thermostat switch is an automatic resetting device and should be connected directly into a latched (locked out) power down type circuit.

---

Incorrect motor resolver or encoder phasing can cause erratic operation, runaway, or damage to the system.

---

The leads of the three-phase synchronous motor are brought out to Pins A, B, and C of the motor connector. Pin D is ground for the motor. Refer to Figure 2.5 for pin connections.

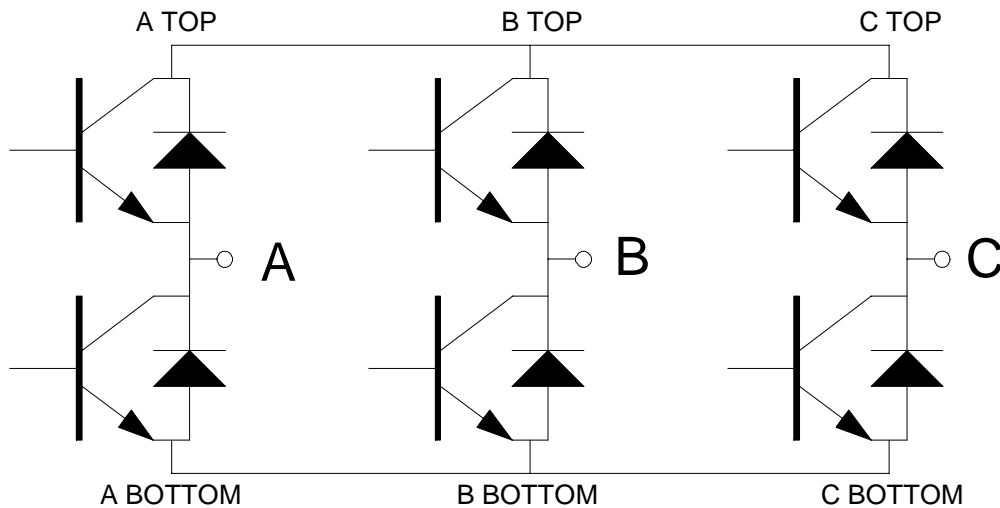

**Figure 2.5. Motor Connections**

Terminate Pins A, B, and C of the motor connector to Ma, Mb, and Mc, respectively, on the power terminal block located on the front of the SERVOSTAR SP Series Drive amplifier. Terminate Pin D at the SERVOSTAR SP Series Drive chassis ground screw. Refer to System Wiring Diagram C-97514 in Appendix H Drawings, and the appropriate motor HD (hook-up) drawing.

## 2.8 INSTALLATION CHECKLIST

Refer to SERVOSTAR SP Series Drive Wiring Diagram. See Appendix H.

Before applying power to the Power Supply and SERVOSTAR SP Series Drive, check the following items to ensure proper operation:

---

**To prevent damage to the equipment, the motor and resolver, the AC line voltage, and the DC bus voltages must be connected as indicated by SERVOSTAR SP Series Drive Wiring Diagram .**

---

### 2.8.1 Checking the Motor Wiring

Disconnect both the motor stator connector from the motor. Using an ohmmeter, check the continuity of each motor stator lead between the motor stator connector pin and the SERVOSTAR SP Series Drive. The motor stator should be connected according to SERVOSTAR SP Series Drive Wiring Diagram.

### 2.8.2 Checking the AC Line Voltages

Open the circuit breaker or remove the fuses in the Main AC lines that are connected to the Power Supply at L<sub>a</sub>, L<sub>b</sub>, and L<sub>c</sub>. Remove Connector C7 from the Power Supply.

Apply only the AC main power. Use an AC voltmeter to check and record the 1- or 3-phase line-to-line voltage at the circuit breaker or fuse holders. Remove power. Note the model number of the Power Supply and refer to Appendix C to confirm the correct Main AC voltage level.

Apply only the AC control power. Use an AC voltmeter to check and record the single-phase voltage at Connector C7 of the Power Supply. Remove power. Note the model number of the Power Supply and refer to Appendix E to confirm correct Control AC voltage level.

If the voltage levels are within the specifications listed in Appendix E, proceed with the Check-Out procedure.

Close the circuit breaker or re-install the fuses for the Main AC input power. Re-install all connectors.

### 2.8.3 Checking the DC Bus Voltages

---

**Allow sufficient time (after removing power from the system) for the voltage to bleed down before connecting or disconnecting wires at the bus.**

---

Remove power.

Remove the Bus+ and Bus- leads from the Power Supply power terminal block. Remove mating Connector C1 from the Power Supply.

Apply power.

Check and record the Main DC Bus Voltage output at (+) with respect to (-) on the Power Supply terminal block. Check and record the unregulated DC voltage levels at Connector C1 of the Power Supply. They should be  $\pm 15$  to 16 (pin 1 to pin 3) and + 7.5 to 8.5 (pin 4 to pin 3) VDC.

Remove power.

Note the model number of the Power Supply and confirm DC voltage levels.

If the voltage levels are within the specifications listed in Appendix E, proceed.

WAIT FOR THE BUS TO BLEED DOWN and reconnect the B(+) and B(-) leads to the power terminal block of the Power Supply. Be careful to reconnect the leads with the proper polarity. Re-install Connector C2 on the Power Supply. It may take up to 2 minutes for the Bus to discharge to below 50V.

---

**Failure to observe correct polarity will result in damage to the SERVOSTAR SP Series Drive.**

---

## SECTION 3

# OPERATION

### 3.1 INTRODUCTION

The information in this Section will enable you to become familiar with system components and their dependence upon one another. Also, it will help you ensure each component is configured and functions properly. At this point, all safety stops and other precautions should be in place and working properly. Be prepared to stop the machine if necessary.

### 3.2 INITIAL START-UP

You should now be ready to supply power to test the servo systems functions and features. Work with only one axis section at a time. Confirm all other SERVOSTAR SP Series Drive amplifiers are inhibited, meaning the enable circuits are open.



**CAUTION**

---

**Incorrect servo-to-position loop phasing can cause excursion oscillations, or runaways.**

---

Appropriate precautions should be taken to stop the machine if necessary. Limit switches and safety devices should be in place.

### 3.3 SEQUENCE OF OPERATIONS

This section contains a basic start-up sequence that should be followed the first time the servo system is initialized. **READ THIS ENTIRE SECTION BEFORE PERFORMING ANY OF THESE PROCEDURES.** When you apply power to the system, pay special attention to the LEDs on the SERVOSTAR SP Series Drive front panel. The CONTROL VOLTS (green) LED should be illuminated. This indicates that the system is functioning properly. Should a FAULT (red) LED remain on for more than a instant, immediately disconnect power and consult Section 5 - Troubleshooting.

Apply power. Enable only one SERVOSTAR SP Series Drive. The Green Enabled LED should illuminate. Observe the action of the machine. If the direction of the motor shaft rotation is reversed (motor shaft turns in the wrong direction), remove power.

If the servo system performed properly, then read Section 4 - Maintenance for adjustments and other information that may be helpful in adapting your system to your own applications.



## SECTION 4

# MAINTENANCE

### 4.1 INTRODUCTION

The information in this Section will enable you to maintain the systems components ensuring smooth, efficient operation of the motor.

### 4.2 PREVENTATIVE MAINTENANCE

---



**Preventative maintenance to this equipment must be performed by qualified personnel familiar with the construction, operation, and hazards involved with the application.**

---



**Electronic components in this amplifier are static sensitive. Use proper procedures when handling component boards.**

---

Preventative maintenance should be performed with the SERVOSTAR SP Series Drive system out of operation and disconnected from all sources of power.

#### 4.2.1 Transient Voltages

---



**All transient-producing devices must be properly suppressed.**

---

Solid state controls of the SERVOSTAR SP Series Drive may be affected by transient voltages. These voltages are in excess of the specified voltage for any given circuit. When these peak voltages occur, even for less than a second, permanent damage to the SERVOSTAR SP Series Drive can occur.

In order to help avoid transient voltages that may interfere with electronic circuit functions within the Power Supply and SERVOSTAR SP Series Drive, all switched inductive devices or their wiring (solenoids, relay coils, starter coils, etc.) must be suppressed. A 220 ohm, 1/2 watt resistor in series with a 0.5 micro farad, 600 volt capacitor or equivalent is suggested.

### 4.2.2 Surge Current

Excessive current greater than that of the specified limits of the Power Supply and SERVOSTAR SP Series Drive can cause permanent damage to the system. Current limiting means are recommended to protect from these currents.



**CAUTION**

**If the short circuit inrush current generated by the power source is in excess of 5000 amps RMS symmetrical current, an isolation transformer or line inductor must be utilized in the incoming power circuit. Failure to observe this precaution could result in damage to, or destruction of the Power Supply and SERVOSTAR SP Series Drive.**

Input transformers step up or step down input voltage and can be either autotransformers or isolation transformers. Isolation transformers help eliminate the following:

- Damaging AC line voltage transients reaching the Power Supply and SERVOSTAR SP Series Drive.
- Damaging currents which may develop if a point inside the Power Supply or SERVOSTAR SP Series Drive becomes grounded.

### 4.2.3 Electrical Noise

The low levels of energy in the SERVOSTAR SP Series Drive control circuits may cause them to be vulnerable to electrical noise. Sources of electrical noise are those pieces of equipment that have large, fast changing voltages and currents when they switch on and off. These devices have the capability of inducing critical current and voltage transients on their respective power lines. These transients must be accommodated for with noise immunity provisions.

Electrical noise is prevented with the same methods as Surge Current and Transient Voltages. However, there are other methods of preventing electrical noise. Such as:

- Maintain physical separation between electrical noise sources and the SERVOSTAR SP Series Drive amplifier.
- Maintain physical separation between electrical noise sources and the SERVOSTAR SP Series Drive control wiring. This can be accomplished by using separate conduits or wiring trays for control wiring and power wiring.
- Use twisted-pair wiring for control circuits of the SERVOSTAR SP Series Drive.
- Follow good grounding practices when wiring the Power Supply and SERVOSTAR SP Series Drive. Be careful not to create a grounding loop with multiple ground paths. Follow the NEC's provisions on grounding.

### 4.2.4 Radio Frequency Energy



**NOTE**

**This equipment generates radio frequency energy.**

This equipment can radiate radio frequency energy and must be installed and used in accordance with this installation and service manual in order to prevent possible interference with radio communications or other electronic equipment.

## 4.3 PERIODIC MAINTENANCE

Periodic maintenance must be performed by qualified personnel familiar with the construction, operation, and hazards involved with the SERVOSTAR SP Series Drive and its application. Power should be disconnected during all maintenance procedures.

### **4.3.1 Ventilation**

The Power Supply and SERVOSTAR SP Series Drive should be mounted vertically to allow maximum ventilation of the components. This configuration allows the heat generated by the components to vent through the top and draft in cooler air through the bottom. The top and bottom of the components are vented to allow this drafting to occur. These ventilation passages should be kept open. Inspect all fans on a regular basis.

### **4.3.2 Grounding Integrity**

The method employed for grounding or insulating the equipment from ground should be checked to assure its integrity on a regular basis. This check should be performed with the power off and the testing equipment grounded.



## SECTION 5

# TROUBLESHOOTING

### 5.1 INTRODUCTION

The information in this Section will enable you to isolate and resolve common system hardware problems. The troubleshooting methods in this manual isolate each component from the system until the problem is resolved.

### 5.2 FIELD SERVICEABILITY

---



**CAUTION**

**Dangerous voltages exist in this equipment. Also, motor temperature may exceed 100°C. Extreme caution should be exercised when troubleshooting this equipment. Only qualified individuals should attempt to install, setup, operate, or troubleshoot this equipment.**

---

The SERVOSTAR SP Series Drive and Power Supply are designed to promote minimum down time situations. Due to the compact package size and to the fact that there are few user-serviceable components on the modules, it is recommended that they be replaced if they cease to function properly. Return the modules, in their entirety, to Industrial Drives for repair.

The SERVOSTAR SP Series Drive modules may be interchanged, provided the following guidelines are adhered to:

1. The SERVOSTAR SP Series Drive modules must be the same rating.
2. The compensation header (if used) is loaded with the same values. (Modes 2 and 3 only).

Before beginning the troubleshooting process, consider the following points:

- I. There are four (4) distinct areas within which a fault may occur:
  - A. External Interface (Circuitry external to, but connecting to, the SERVOSTAR SP Series Drive.)
  - B. SERVOSTAR SP Series Drive Amplifier Module
  - C. PA Power Supply Module
    1. Main DC bus voltage
    2. Control DC bus voltages
    3. Shunt Regulator Regeneration Circuitry
    4. Soft-Start Circuitry
  - D. Motor
    1. Winding
    2. Feedback Device
- II. There are only two (2) basic fault characteristics to be considered:
  - A. The motor exhibits very low torque or is totally inoperative.
  - B. The motor is erratic or exhibits an improper mode of operation.

### 5.3 SYMPTOMS AND CORRECTIONS

If the motor does not respond or responds in a manner other than with smooth operation, remove power and troubleshoot the system with the following guidelines.

#### 5.3.1 The Motor Exhibits Very Low Torque or is Totally Inoperative

Prerequisites for motor movement:

1. The SERVOSTAR SP Series Drive and Power Supply must be wired correctly, per SERVOSTAR SP Series Drive Wiring Diagram.
2. All power must be present.
3. The SERVOSTAR SP Series Drive must be in the Enable mode as indicated by the green LED.
4. Fault circuits must not be activated. Fault modes are identified by red LED's located on the front of the SERVOSTAR SP Series Drive and Power Supply modules.
5. Input command must be present.

#### 5.3.2 The Motor is Erratic or Exhibits an Improper Mode of Operation.

Prerequisites for proper motor operation:

1. Proper grounding scheme must be provided. The motor ground wire should be connected as shown by SERVOSTAR SP Series Drive Wiring Diagram.
2. Motor armature leads must not be run in conduit or wire ducts with any signal carrying conductors.
3. The feedback leads and motor armature leads must be wired according to SERVOSTAR SP Series Drive Wiring Diagram.
4. The motor system resolver must be set at its zero point.

#### 5.3.3 SERVOSTAR SP Series Drive Status LED's

The status of the SERVOSTAR SP Series Drive modules is indicated by two (2) Green and four (4) Red LED's. The diagnostic information indicated by these LED's is listed as follows:

- Approximately a half a second after all power is applied, the green CONTROL VOLTS LED on the front of the SERVOSTAR SP Series Drive module should become illuminated to indicate that the Control AC line input voltage is applied.
- No fault (red) LED's should be illuminated.

The red short circuit LED is activated by protection circuitry with the power device. It will activate on an over-temp or shorted output load condition.

When the red OVER-CURRENT LED becomes illuminated, it indicates an over-current condition has occurred (usually due to excessive current command). The SERVOSTAR SP Series Drive will become latched in the Inhibit mode.

If the red OVER-VOLTS LED becomes illuminated, the SERVOSTAR SP Series Drive will become latched in the Inhibit mode, indicating the presence of excessive main DC bus voltage.

When the red UNDER-VOLTS LED becomes illuminated, the SERVOSTAR SP Series Drive will be put into the Inhibit mode (but not latched) indicating the main DC Bus is insufficient or absent.

The Outputs contacts located within the Power Supply power supply module will not be affected by any faults occurring within the SERVOSTAR SP Series Drive.

The green ENABLED LED must be illuminated (by energizing the remote enable while no drive faults exist) to get power out of the SERVOSTAR SP Series Drive.

More diagnostic information about the SERVOSTAR SP Series Drive is listed in the Table 5.1.

### 5.3.4 Power Supply Amp Status LED's

The status of the Power Supply module is indicated by one (1) Green and one (1) Yellow LED's. (Not available on all models.) The diagnostic information indicated by these LED's is as follows:

- Approximately 0.25 seconds after the main power is applied, the green DC BUS LED will become illuminated to indicate the presence of voltage on the main DC bus capacitors and the Bus-Up output will turn on. Voltage indication may range in magnitude from over 300 VDC, during normal operation with AC line voltage applied, to below 50 VDC when the line voltage is removed but the bus capacitors have not completely discharged.
- The yellow REGEN LED (not available on all models) is for monitoring purposes only. When this LED becomes illuminated, the shunt regulator regeneration circuit is active. The Regen output will also turn on whenever the shunt regulator is active.
- Faults occurring within the Power Supply will cause the Bus-Up output to turn off. (Not available on all models).

More diagnostic information about the Power Supply LED's is listed in Table 5.2.

### 5.3.5 SERVOSTAR SP Series Drive or Power Supply Reset Procedures

To reset the fault latches within the SERVOSTAR SP Series Drive and all fault latches within the Power Supply power supply units, remove all AC line input voltage for at least five (5) minutes or until the power stage capacitors are fully discharged. All other fault latches within the SERVOSTAR SP Series Drive amplifiers may be reset by toggling the RESET input circuit to common or by removing and reapplying the input voltage as described previously.

**Table 5.1. SERVOSTAR SP Series Drive Status LED Indicator Troubleshooting**

<b>SYMPTOM</b>	<b>PROBABLE CAUSE</b>
1) Control Volts LED (Green) <u>Not</u> Illuminated	(a) Control AC line input voltage out of spec or had a momentary interruption.
	(b) Unregulated logic bus not applied to SERVOSTAR SP Series Drive from Power Supply due to defective wiring or being miswired (fuses inside of Power Supply may be blown).
	(c) Defective logic bus supply in SERVOSTAR SP Series Drive or Power Supply or blown logic bus fuse.
	(d) Defective SERVOSTAR SP Series Drive.
2) Over-current LED (RED) Illuminated	(a) When this LED becomes illuminated, an over-current condition [usually due to excessive current command] is indicated. If this LED becomes illuminated, reduce input commands to zero and reset the fault via the reset input or cycling control power. If it doesn't reset then suspect a faulty SERVOSTAR SP Series Drive.
3) Over-volts LED (RED)	(a) This LED will become illuminated if the Main DC Bus rises above 430 VDC. This can happen due to Power Supply fault or inadequately sized shunt regulator regeneration resistor.
4) Under-volts LED (RED) Illuminated	(a) This LED will become illuminated if the Main DC Bus is insufficient or absent.
	(b) If this LED is illuminated and the Green DC Bus LED on the PI unit is not illuminated, suspect incoming power not applied or blown fuse.
	(c) If this LED is illuminated and the Green DC Bus LED on the PI unit is illuminated, suspect power supply has switched to protection mode. Drop power and wait one minute before re-applying power. If it still doesn't come up, suspect faulty power supply

**Table 5.2. Power Supply Status LED Indicator Troubleshooting**

<b>SYMPTOM</b>	<b>PROBABLE CAUSE</b>
1) DC BUS LED (Green) <u>Not</u> Illuminated	(a) Main DC Bus insufficient or not present. AC input power not applied; check input line fuses.
2) Regen LED (Yellow) Illuminated or Flashing	(a) Not a fault condition. Indicates regeneration circuit activity.

# **APPENDIX A**

## **WARRANTY INFORMATION**

Kollmorgen Motion Technologies Group warrants that equipment, delivered by it to the Purchaser, will be of the kind and quality described in the sales agreement and/or catalog and that the equipment will be free of defects in design, workmanship, and material.

The terms and conditions of this Warranty are provided with the product at the time of shipping or in advance upon request.



# APPENDIX B

## CUSTOMER SUPPORT

---

Kollmorgen is committed to quality customer service. Our goal is to provide the customer with information and resources as soon as they are needed. This one number provides order status and delivery information, product information and literature, and application and field technical assistance.

Note: If you are unaware of your local sales representative, please contact us at the number below. Visit our web site for MotionLink software upgrades, technical articles, and the most recent version of our product manuals.

**Kollmorgen Customer Support Network**  
**203 Rock Road Suite A**  
**Radford, VA 24141**  
**Phone: (888) 774-KCSN (5276)**  
**Fax: (540) 639-1640 Inside Sales**  
**Fax: (540) 639-1574 Technical Support**  
**Email: [servo@Kollmorgen.com](mailto:servo@Kollmorgen.com)**  
**Http://www.Kollmorgen.com**

**B.1.1 Southern Region**

Kollmorgen Motion Technologies Group  
118 North Avenue  
Suite H  
Jonesboro, GA. 30236

Telephone: (770) 472-4100  
Fax: (770) 472-4342

**B.1.5 Northern Europe**

Kollmorgen Hightech Ltd.  
POB 147  
Keighley  
Yorkshire BD20 6XB  
UK

Telephone: 44-1535-607688  
Fax: 44-1535-680520

**B.1.2 Eastern Region**

Kollmorgen Motion Technologies Group  
49 Mall Drive  
Commack, New York 11725-5703

Telephone: (516) 864-1000  
Fax: (516) 864-2084

**B.1.6 Southern Europe**

Servotronix Ltd.  
12 Hachoma St.  
POB 5096  
Rishon Le Zion 75105  
Israel

Telephone: 972-3-9616577  
Fax: 972-3-9616579

**B.1.3 Midwest Region**

Kollmorgen Motion Technologies Group  
1985 W. Big Beaver Road  
Suite 212  
Troy, MI 48084-3409

Telephone: (810) 816-8740  
Fax: (810) 816-9855

**B.1.7 Far East**

Kollmorgen Motion Technologies Group  
49 Mall Drive  
Commack, NY 11725

Telephone: (516) 864-1000  
Fax: (516) 864-2084

**B.1.4 Western Region**

Kollmorgen Motion Technologies Group  
23011 Moulton Parkway, Unit H5  
Laguna Hills, California 92653

Telephone: (714) 518-3626  
Fax: (714) 581-3628

# APPENDIX C

## MODEL NUMBERS

**Table C.1. PA Model Number Scheme**

<b>EXAMPLE:</b>	<u>PA</u>	<u>08</u>	<u>XX</u>
<b>LEGEND:</b>	A	B	C

LEGEND	DEFINITION
A	Power Supply Unit
B	08, 14, 28, 50, 75 or 85 AC Line Current, RMS.
C	Options.
00	Standard - No Option (with soft-start and on 28 amp model, regen also)

**Table C.2. ER-External Resistor Kit Model Number Scheme**

<b>EXAMPLE:</b>	<u>ER-</u>	<u>30-</u>	<u>XX</u>
<b>LEGEND:</b>	A	B	C

LEGEND	DEFINITION
A	External Resistor Kit for PS.
B	Resistor Rating.
30	8.8 ohms, 400W
C	Options (None Available at this Printing).

**Table C.3. SERVOSTAR SP Series Drive Model Number Scheme**

<b>EXAMPLE:</b>	<u>SP</u>	<u>1</u>	<u>03</u>	<u>XX*</u>	-1	<u>204A</u>	<u>Z</u>
<b>LEGEND:</b>	A	B	C	D	E	F	G

LEGEND	DEFINITION
A	SERVOSTAR Based SERVOSTAR SP
B	1 = Standard Interface ; 2 = Delta Tau Interface
C	03, 06, 10, 20, 30, 55 Output RMS Current Per Phase, Continuous.
D	Options.
01	Standard Unit.
E	Voltage: 1 = 160V Bus, 2 = 325V Bus
F	Motor and Winding Destination
G	Compensation Mode
2	Compensation Header Populated for Mode 2 Operation
3	Compensation Header Populated for Mode 3 Operation

\* Omit \ D E for Mode 1 operation or for user-built Compensation header.

**Table C.4. Compensation Card Model Designator**

<b>EXAMPLE:</b>	<u>CMP-</u>	<u>SP103</u>	<u>2204A</u>	<u>2</u>
<b>LEGEND:</b>	A	B	C	D

LEGEND	DEFINITION
A	Compensation Card.
B	Amplifier Base Model Number.
C	Voltage, Motor, Winding, and Compensation Designator.
D	Mode Designator

**C.1 CABLE, BUS WIRE, AND MATING CONNECTOR KIT INFORMATION**

Extra or spare bus wire and complete cable assemblies are available from KMTG. Mating connector kits are available from KMTG or may be purchased directly from the connector vendor.

**C.2. CABLE MODEL NUMBER SCHEME FOR INDIVIDUAL CABLE**

Individual cables can be provided by GC (Goldline Cable) Models. To assist in ordering, the model number scheme for an individual cable is as follows:

**Table C.5. Cable Model Number Scheme for Individual Cable (Bayonet Type Connector)**

<b>EXAMPLE:</b>	<u>GC</u> -	<u>M2</u> -	<u>4/5</u> -	<u>03</u>
<b>LEGEND:</b>	A	B	C	D

LEGEND	DEFINITION
A	Goldline Cable With Bayonet-Type Connector (individual cable).
B	Motor Power Cable with Mating Plug or Feedback/Option Cable.
M1	B, M-10X Motors.
M2	B, M-20X Motors (3 to 10 amp).
M2B	B, M-20 X Motors (20 amp).
M4	B, M-40X Motors (3 to 20 amp).
M4B	B, M - 40X Motors (30 amp.)
M6A	B, M-60X-X-AX & BX Motors (up to 40 amps continuous).
M6B	B, M -60X-X-AX & BX Motors (up to 65 amps continuous).
M8A	B, M -80X-X-AX & BX Motors (up to 65 amps continuous).
M8B	B, M -80X-X-AX & BX Motors (up to 115 amps continuous).
R	System Resolver Only.
<b>LEGEND</b>	<b>DEFINITION</b>

C		Amplifier Termination.
	A	Ring/Spade Lug Terminals.
	N	Not Terminated.
D		Cable Length to Motor. 3 to 75 Meters in 3-Meter Increments.

**Table C.6. Cable Model Number Scheme for Individual Cable  
(Screw Type Connector)**

<b>EXAMPLE:</b>	<u>G</u> <u>C</u> <u>A</u> -	<u>M</u> <u>4</u> -	<u>4</u> / <u>5</u> -	<u>0</u> <u>3</u>
<b>LEGEND:</b>	<b>A</b>	<b>B</b>	<b>C</b>	<b>D</b>

LEGEND	DEFINITION
A	Goldline Cable with screw-type connector (individual cable).
B	Motor Power Cable with Mating Plug or Feedback/Option Cable.
M4	B, M -40X Motors (up to 40 amps continuous).
M4B	B, M-40X Motors (30 amps).
M6A	B, M -60X Motors (up to 40 amps continuous).
M6B	B, M -60X Motors (up to 65 amps continuous).
M8A	B, M -80X Motors (up to 65 amps continuous).
M8B	B, M -80X Motors (up to 115 amps continuous).
C	Amplifier Termination.
A	Ring/Spade Lug terminals.
N	Not Terminated.
D	Cable Length to Motor. 3 to 75 Meters in 3-Meter Increments.



## APPENDIX D

# CONNECTOR KITS & TOOLS

### D.1 INTRODUCTION

Mating connectors are customer furnished items which may be ordered either from Kollmorgen Motion Technologies Group or purchased directly from the connector vendor. Ordering information is as follows:

**Table D.1. SERVOSTAR SP Series Drive Connector Kit**

<b>CONNECTOR KIT Part Number: CK102</b>			
<b>Connector</b>	<b>Description</b>	<b>Molex Part No.</b>	<b>KMTG Part No.</b>
C2	Connector Housing, 12 Position Female	39-01-2125	A-83908-012
C3	Connector Housing, 16 Position Female	39-01-2165	A-83908-016
C2, C3	PIN, Female, (18-24 AWG)	39-00-0039	A-83909-002

**Table D.2. Connector Tools**

<b>CONNECTOR TOOLS (PINS, MINI FIT JR.) FROM MOLEX</b>		
<b>Description</b>	<b>Engineering Number</b>	<b>Order Number</b>
Hand Crimping Tool	HTR-60622	11-01-0122
Extractor Tool	HT-60630A	11-03-0038
MOLEX TELEPHONE NUMBER: (708) 969-4550		

Kollmorgen Motion Technologies Group supplies Connector Kit P/N SP1C100 with each SERVOSTAR SP Series Drive Module.



# APPENDIX E

## SPECIFICATIONS

### E.1 INTRODUCTION

The Specifications for the Power Supply and SERVOSTAR SP Series Drives are provided in this appendix. Derating information is also included for environments with high ambient temperatures. As a general rule, the failure rate of solid state components doubles for every ten degrees Celsius rise in temperature. This exponential failure rate is strong incentive for lower ambient temperatures.

### E.2 POWER SUPPLIES

The following information describes the power supplies used with SERVOSTAR SP Series Drives. They are standard members of the SERVOSTAR family.

#### E.2.1 Logic Supply Module PA-LM

The Logic Supply Module is designed to supply power for up to two SERVOSTAR SP Series drives. It does not supply Motor Bus Power. It is used where the application requires more than 4 axes of drives running from the same power supply or where bus power is derived elsewhere.

#### E.2.2 Power Supply PA08xx

This modular power supply has two sections, a main dc bus, and logic power.

The main dc bus section consists of input line filters, three-phase diode bridge, bus caps, and soft-start circuitry (to limit inrush currents). The main dc bus section is designed to operate from either 115 VAC single-phase or 230 VAC three-phase input mains. A green LED indicates when there is voltage on the bus caps.

The logic power section consists of a universal input SMPS for generating the required  $\pm 15$  VDC and +7.5 VDC Logic Power for one or two SERVOSTAR SP Series Drive amplifiers. The SMPS input is connected to the  $L_A$  and  $L_B$  main dc bus input terminals.

#### E.2.3 Power Supply PA14xx and PA28xx

These modular power supplies have two sections, a main dc bus, and logic power.

The main dc bus section is designed to operate from 115VAC for the PA14 or 230 VAC three-phase for the PA28. Features of these power supply include:

- A green LED to indicate when there is voltage on the bus caps.
- Relay output to indicate the power is energized and operating.
- Soft-start circuitry (to limit inrush currents).
- Internal/External Regen (shunt regulator) with a yellow LED indicator.

The power supply has a 40W rated internal resistor, for light duty applications. For heavier duty applications, a jumper on the front terminal block is removed and an external resistor is connected.

The relay output is a normally open contact which closes upon application of power to the power supply and after soft-start is completed. The contacts will open if the internal Regen resistor or main heatsink becomes too hot, or if there is improper power supply output.

The logic power section consists of a 115VAC (PA14xx) or a 230V (PA28xx) input SMPS for generating the required  $\pm 15$  VDC and +7.5 VDC Logic Power. The PA14xx can drive up to 2 SERVOSTAR SP Series Drive amplifiers. The PA28xx can drive up to 4 SERVOSTAR SP Series Drive amplifiers. The Regen resistor is fuse protected.

#### **E.2.4 Power Supply PA50xx / PA75xx / PA85xx**

The PA50xx, PA75xx, and PA85xx Power Supply units are identical except that the 75 amp and 85 amp units have higher power components and more capacitive filtering. Neither of the units have internal regeneration but each has the electronics internal and requires an external resistor.

The main dc bus section is designed to operate from 230 VAC three-phase input mains. Features of this power supply include:

- A green LED to indicate when there is voltage on the bus caps.
- Relay output to indicate the power is energized and operating.
- Soft-start circuitry (to limit inrush currents).
- External Regen (shunt regulator) with a yellow LED indicator.
- A red fault LED indicator showing the softstart has not closed.

The relay output is a normally open contact which closes upon application of power to the power supply and after soft-start is completed. The contacts will open if the internal Regen resistor or main heatsink becomes too hot, or if there is improper power supply output. The logic power section consists of a 230V input SMPS for generating the required  $\pm 15$  VDC and +7.5 VDC Logic Power for up to four SERVOSTAR SP Series Drive amplifiers. Up to 4 amplifiers may be powered by this logic supply.

<b>Table E-1. SERVOSTAR Power Supply Specifications</b>						
	<b>Power Supply Model</b>	<b>PA08</b>	<b>PA28</b>	<b>PA50</b>	<b>PA75</b>	
<b>Main Input Power</b>	Voltage (Vac) (line to line)	115 to 230	208 to 230	208 to 230	208 to 230	
	1 Phase / 3 Phase	1/3	1/3	3	3	
	Frequency +15 - 5%	50/60				
<b>Main Input Current</b>	Rated current (amps)	8	14 @ 1 Phase 28 @ 3 Phase	50	75	
	Max. current, 2 sec. (amps)	16	28 @ 1 Phase 36 @ 3 Phase	75	115	
<b>Output Power</b>	Output volts (Nominal)	160/325	325	325	325	
	Output current	8/8	14/28	50	75	
<b>Logic Power Input</b>	Input Voltage (volts AC) 50/60 Hz	115 to 230	208 to 230	208 to 230	208 to 230	
	Input Current (amps Max.)	1	1	1	1	
<b>Logic Power Output</b>	Logic voltage (volts)	8				
	Logic current (amps)	2.2	4.4	4.4	4.4	
	15V Voltage (volts)	+/-15				
	15V Current (amps)	0.75	1.7	1.7	1.7	
<b>Protective Functions</b>	Over temperature trip	n/a	90	90	90	
	Other	Under volts, Over Temp, Softstart, Internal Fusing				
<b>Regen Operation</b>	Regen trip voltage (on) (Vdc nom.)	390	390	390	390	
	Regen off voltage (Vdc nom.)	375	375	375	375	
<b>Internal Shunt Regulator</b>	Peak current (amps)	n/a	32	n/a	n/a	
	Resistance (ohms)	n/a	12.5	n/a	n/a	
	Watts	n/a	40	n/a	n/a	
<b>External Shunt Regulator</b>	Peak current (amps)	n/a	45	100	200	
	Minimum resistance (ohms)	n/a	8.8	4.5	2.2	
	Watts	n/a	400	1000	2000	
<b>Soft Start</b>	Surge current (max. amps)	30	50	40	40	
	Charge time (max. sec)	0.75	0.25	0.5	0.75	
<b>Environment</b>	Internal heat dissipation (watts)	45 w	130 w	200 w	275 w	
	Operation temperature (°C)	0 to 45				
	Storage temperature (°C)	-20 to 70				
	Ambient humidity	10% to 90%				
	Atmosphere	With no Corrosive gasses or dust				
	Altitude	3300 feet max. without derate				
<b>Package</b>	Vibration	0.5 g				
	Weight lb (kg) (Typical)	4.74 (2.16)	8.18 (3.72)	14.32 (6.51)	14.52 (6.6)	
	Height in (mm) (Max)	10.39 (264)	10.39 (264)	16 (406.4)	16 (406.4)	
	Width in (mm) (Max)	2.5 (63.5)	4.9 (124.4)	5.7 (144.6)	5.7 (144.6)	
Depth in (mm) (Max)	7.95 (202)	7.95 (202)	11.2 (284)	11.2 (284)		

<i>Table E-1. SERVOSTAR Power Supply Specifications (Cont.)</i>				
	<b>Power Supply Model</b>	<b>PA14</b>	<b>PA-LM</b>	
<b>Main Input Power</b>	Voltage (Vac) (line to line)	115	n/a	
	1 Phase / 3 Phase	1	n/a	
	Frequency +15 - 5%	50/60	n/a	
<b>Main Input Current</b>	Rated current (amps)	14	n/a	
	Max. current, 2 sec. (amps)	28	n/a	
<b>Output Power</b>	Output volts (Nominal)	160	n/a	
	Output current	14	n/a	
<b>Logic Power Input</b>	Input Voltage (volts AC) 50/60 Hz	115	115 to 230	
	Input Current (amps Max.)	1	1	
<b>Logic Power Output</b>	Logic voltage (volts)			8
	Logic current (amps)	2.2	2.2	
	15V Voltage (volts)			+/-15
	15V Current (amps)	0.75	0.75	
<b>Protective Functions</b>	Over temperature trip (degrees)	90	n/a	
	Other	PA14 - Under volts, Over Temp, Softstart, Internal Fusing PA-LM - Fusing, LED Indicators, Short Circuit, Over Temp		
<b>Regen Operation</b>	Regen trip voltage (on) (Vdc nom.)	200	n/a	
	Regen off voltage (Vdc nom.)	190	n/a	
<b>Internal Shunt Regulator</b>	Peak current (amps)	30	n/a	
	Resistance (ohms)	7.5	n/a	
	Watts	40	n/a	
<b>External Shunt Regulator</b>	Peak current (amps)	40	n/a	
	Minimum resistance (ohms)	4.25	n/a	
	Watts	300	n/a	
<b>Soft Start</b>	Surge current (max. amps)	20	12	
	Charge time (max. sec)	0.25	0.03	
<b>Environment</b>	Internal heat dissipation (watts)	70 w	n/a	
	Operation temperature (°C)			0 to 45
	Storage temperature (°C)			-20 to 70
	Ambient humidity			10% to 90%
	Atmosphere			With no Corrosive gasses or dust
	Altitude			3300 feet max. without derate
<b>Package</b>	Vibration			0.5 g
	Weight lb (kg) (Typical)	8.18 (3.72)	2.5 (1.32)	
	Height in (mm) (Max)	10.39 (264)	6.25 (158.8)	
	Width in (mm) (Max)	4.9 (124.4)	2.25 (56.9)	
	Depth in (mm) (Max)	7.95 (202)	7.3 (185.4)	

	Amplifier Model	SPx03	SPx06	SPx10	SPx20	SPx30	SPx55
<b>Main Input Power</b>	Voltage (Vdc)	125 to 360	125 to 360	125 to 360	295 to 360	295 to 360	295 to 360
	Input power @ dc (kva)	0.63-1.4	1.26-2.79	1.96-4.34	8.68	13.33	24.45
	Under volt trip (on power-up)	90 Vdc	90 Vdc	90 Vdc	255 Vdc	255 Vdc	255 Vdc
	Under volt trip (normal)	90 Vdc	90 Vdc	90 Vdc	125 Vdc	125 Vdc	125 Vdc
	Over volt trip	430 Vdc	430 Vdc	430 Vdc	430 Vdc	430 Vdc	430 Vdc
<b>Control Input Power</b>	Logic Supply Voltage (Vdc) ±5%	8	8	8	8	8	8
	Logic Supply Current (Amp)	0.2	0.2	0.2	0.2	0.2	0.2
	Analog Supply (Vdc)	+15/-15	+15/-15	+15/-15	+15/-15	+15/-15	+15/-15
	Analog Supply Current (mA)	200	320	330	450	420	530
<b>Output Power</b>	Continuous Power (kw) (45°C ambient) @ 115 Vac 1 ph	0.55 kw	1.1 kw	1.7 kw	n/a	n/a	
	Continuous Power (kw) (45°C ambient) @ 230 Vac 3 ph	1.1	2.2	3.6	7.3	11	20
	Rated output current (amps)	3	6	10	20	30	55
	Max. current for 2 sec. (amps)	6	12	20	40	60	110
	Rated PWM switching frequency (kHz)	16	16	16	8	8	8
	Motor current ripple (kHz)	32	32	32	16	16	16
	Form factor (rms/avg.)	≤1.01	≤1.01	≤1.01	≤1.01	≤1.01	≤1.01
<b>Analog</b>	Analog Input Scaling (Modes 2 & 3) (Amps per volt)	0.85	1.70	2.83	5.66	8.48	15.55
<b>Scaling</b>	Current Feedback Scaling (Amps per volt)	1.06	2.12	3.53	7.07	8.10	19.44
<b>Internal Heat Loss</b>	Dissipation (Watts)	37	84	120	240	254	465
<b>Environmental</b>	Operating Temperature (°C)	0 to 45					
	Storage Temperature (°C)	-20 to 70					
	Humidity (Non Condensing)	10% to 90%					
	Atmosphere	No Corrosive Gas or Dust					
	Altitude	3300 Feet Without Derating					
	Vibration	0.5g					
<b>Protective Functions</b>		Over Current, Over Volts, Under volts, Control Volt Loss, Over Temp					
	Over temperature trip (°C)	3 to 20 amp drives 118 °c and 90 °c for 30 and 55 amp drives					

Digital Input Levels: All Models			
PWM Input Signal Levels (Mode 1)	Top Transistor On	Minimum	2.5V @ 9mA
		Maximum	5.3V @ 36mA
	Top Transistor Off	Maximum	1.25V @ 2.5mA
	Bottom Transistor On	Minimum	-2.5V @ -9mA
		Maximum	-5.3V @ -36mA
	Bottom Transistor Off	Maximum	-1.25V @ -2.5mA
Remote Enable	Input voltage (max.)	Operating Range Nominal	12 to 24V
		Minimum On	10V
		Maximum Off	1V
	Input current @ 24 volts	20 mA	

E. 3 SHOCK AND VIBRATION

Shipping Acceleration Spectra

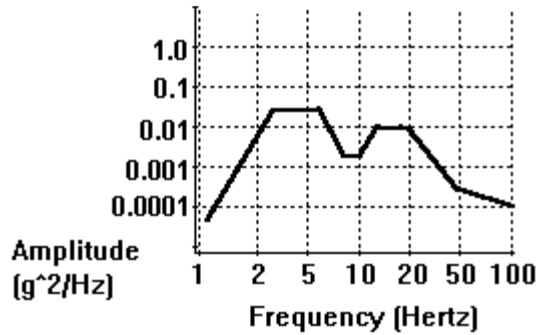

## **APPENDIX F**

### **OPTIONS**

Options are brought into existence from time to time to satisfy specific needs and to add versatility to the product. (Refer to the Model Number Schemes in Appendix C.)

The SERVOSTAR SP Series Drive may be ordered with various mechanical and electrical options, standard or custom designed for particular applications. If a feature is desired which is not covered here, consult the KMTG Regional Sales Office for information on custom designed options.



# APPENDIX G

## CURRENT LOOP COMPENSATION

### G.1 INTRODUCTION

During mode 2 or mode 3 operation the SERVOSTAR SP Series Drive has internal current loops which must be tuned to match a particular motor to a particular motor. Following is a list of the values to be used for this purpose. Three sets of components will be used in mode 2 operation and 1 set in mode 3 operation.

### G.2 REQUIREMENTS

#### G.2.1 Operation Mode

Mode 1: Current loop external to SERVOSTAR SP Series Drive, closed by user.

Mode 2: Current Loop internal to SERVOSTAR SP Series Drive, done by Kollmorgen Motion Technologies Group and shipped with unit or data supplied to user and user installs on supplied header/compensation board: required for three current loops

Mode 3: internal to SERVOSTAR SP Series Drive, done by Kollmorgen Motion Technologies Group and shipped with unit or data supplied to user and user installs on supplied header/compensation board, required for one current loop

#### G.2.2 Compensation Calculation

Resistors  $\leq$

$(2.4 \times 10^6) \times (\text{SERVOSTAR SP Series Drive's Cont. RMS Current Rating}) \times (\text{Motor's min. L-L inductance})$

Capacitors =  $1 / (625 \times \text{Resistor})$

These values for most motor combinations are already calculated and listed in Table G.1 at the end of Appendix G.

### G.3 COMP HEADER

#### Pin Out

pin 1 to pin 16: mode selection jumper 1

pin 2 to pin 15: mode selection jumper 2

pin 3 to pin 14: "A phase" current loop resistor

- pin 4 to pin 13: "A phase" current loop capacitor
- pin 5 to pin 12: "B phase" current loop resistor (not used with Mode 3)
- pin 6 to pin 11: "B phase" current loop capacitor (not used with Mode 3)
- pin 7 to pin 10: "C phase" current loop resistor (not used with Mode 3)
- pin 8 to pin 9: "C phase" current loop capacitor (not used with Mode 3)

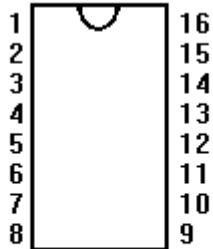

**Mode Selection**

- Mode 1: jumper 1, jumper 2, comp header omitted
- Mode 2: jumper 1 installed, jumper 2 omitted
- Mode 3: jumper 1 installed, jumper 2 installed

*Table G.1. Compensation Values*

MOTOR	RP'S	"R"	"C"
MODEL	RATING	K ohms	uF
B-102A	3/6 AMPS	110kohm	0.015uf
B-102B	3/6 AMPS	25.5kohm	0.056uf
B-104A	3/6 AMPS	100kohm	0.015uf
B-104B	3/6 AMPS	51.1kohm	0.027uf
B-104B	6/12 AMPS	100kohm	0.015uf
B-106A	3/6 AMPS	130kohm	0.01uf
B-106B	6/12 AMPS	68.8kohm	0.022uf
B-106C	6/12 AMPS	47.5kohm	0.033uf
B-106C	10/20 AMPS	75kohm	0.018uf

MOTOR	RP'S	"R"	"C"
MODEL	RATING	K ohms	uF
B-202A	3/6 AMPS	536kohm	2700pf
B-202B	3/6 AMPS	201kohm	7500pf
B-202C	6/12 AMPS	150kohm	0.01uf
B-204A	3/6 AMPS	392kohm	3900pf
B-204B	6/12 AMPS	221kohm	6800pf
B-204C	10/20 AMPS	110kohm	0.01uf
B-204D	10/20 AMPS	90.9kohm	0.015uf
B-206A	3/6 AMPS	392kohm	3900pf
B-206B	6/12 AMPS	201kohm	7500pf
B-206B	10/20 AMPS	332kohm	4700pf

MOTOR	RP'S	"R"	"C"
MODEL	RATING	K ohms	uF
B-206C	10/20 AMPS	110kohm	0.012uf
B-206D	20/40 AMPS	100kohm	0.015uf
B-206E	6/12 AMPS	130kohm	0.01uf
B-206E	10/20 AMPS	221ohm	6800pf
B-206F	3/6 AMPS	392kohm	3900pf
B-402C	10/20 AMPS	182kohm	8200pf
B-404A	6/12 AMPS	562kohm	2200pf
B-404B	10/20 AMPS	301kohm	4700pf
B-404C	20/40 AMPS	130kohm	0.01uf
B-404D	20/40 AMPS	249kohm	5600pf
B-404E	30/60 AMPS	150kohm	0.01uf
B-406A	10/20 AMPS	392kohm	3900pf
B-406B	20/40 AMPS	182kohm	8200pf
B-404C	30/60 AMPS	130kohm	0.01uf
B-404C	40/80 AMPS	182kohm	8200pf
B-406D	20/40 AMPS	357kohm	3900pf
B-602A	10/20 AMPS	332kohm	4700pf
B-602B	20/40 AMPS	130kohm	0.01uf
B-602C	20/40 AMPS	301kohm	4700pf
B-604A	20/40 AMPS	274kohm	5600pf
B-604B	30/60 AMPS	201kohm	6800pf
B-604C	40/80 AMPS	130kohm	0.01uf
B-604C	55/110 AMPS	182kohm	8200pf
B-604D	20/40 AMPS	453kohm	3300pf

MOTOR	RP'S	"R"	"C"
MODEL	RATING	K ohms	uF
B-606A	20/40 AMPS	301kohm	4700pf
B-606B	40/80 AMPS	182kohm	8200pf
B-606B	55/110 AMPS	249kohm	5600pf
B-606C	55/110 AMPS	121kohm	0.012uf
B-606D	30/40 AMPS	221kohm	6800pf
B-606E	40/80 AMPS	274kohm	5600pf
B-606F	20/40 AMPS	680kohm	2200pf
B-802A	30/60 AMPS	392kohm	3900pf
B-802A	40/80 AMPS	499kohm	3300pf
B-802B	40/80 AMPS	274kohm	5600pf
B-804A	40/80 AMPS	499kohm	3300pf
B-804B	55/110 AMPS	301kohm	4700pf
B-806A	55/110 AMPS	332kohm	3900pf
B-806C	30/60 AMPS	499kohm	3300pf
M-103A	3/6 AMPS	110kohm	0.015uf
M-105A	3/6 AMPS	100kohm	0.015uf
M-105B	3/6 AMPS	51.1kohm	0.027uf
M-105B	6/12 AMPS	100kohm	0.015uf
M-107A	3/6 AMPS	130kohm	0.01uf
M-107B	6/12 AMPS	68.8kohm	0.022uf
M-203A	3/6 AMPS	536kohm	2700pf
M-203B	3/6 AMPS	201kohm	7500pf
M-203C	6/12 AMPS	150kohm	0.01uf
M-205A	3/6 AMPS	392kohm	3900pf

MOTOR	RP'S	"R"	"C"
MODEL	RATING	K ohms	uF
M-205B	6/12 AMPS	221kohm	6800pf
M-205C	10/20 AMPS	110kohm	0.01uf
M-207A	3/6 AMPS	392kohm	3900pf
M-207B	6/12 AMPS	201kohm	7500pf
M-207B	10/20 AMPS	332kohm	4700pf
M-403A	3/6 AMPS	536kohm	2700pf
M-403B	6/12 AMPS	249kohm	5600pf
M-403C	10/20 AMPS	182kohm	8200pf
M-405A	6/12 AMPS	562kohm	2200pf
M-405B	10/20 AMPS	301kohm	4700pf
M-405C	20/40 AMPS	130kohm	0.01uf
M-405D	20/40 AMPS	249kohm	5600pf
M-407A	10/20 AMPS	392kohm	3900pf
M-407B	20/40 AMPS	182kohm	8200pf
M-407C	30/60 AMPS	130kohm	0.01uf
M-407C	40/80 AMPS	182kohm	8200pf
M-407D	20/40 AMPS	357kohm	3900pf
M-603A	10/20 AMPS	332kohm	4700pf
M-603B	20/40 AMPS	130kohm	0.01uf
M-603C	20/40 AMPS	301kohm	4700pf
M-605A	20/40 AMPS	274kohm	5600pf
M-605B	30/60 AMPS	201kohm	6800pf
M-605C	40/80 AMPS	130kohm	0.01uf
M-605C	55/110 AMPS	182kohm	8200pf

MOTOR	RP'S	"R"	"C"
MODEL	RATING	K ohms	uF
M-605D	20/40 AMPS	453kohm	3300pf
M-607A	20/40 AMPS	301kohm	4700pf
M-607B	40/80 AMPS	182kohm	8200pf
M-607B	55/110 AMPS	249kohm	5600pf
M-607C	55/110 AMPS	121kohm	0.012uf
M-607E	30/60 AMPS	221kohm	6800pf
M-607E	40/80 AMPS	274kohm	5600pf
M-607F	20/40 AMPS	680kohm	2200pf
M-803A	30/60 AMPS	392kohm	3900pf
M-803A	40/80 AMPS	499kohm	3300pf
M-803B	40/80 AMPS	274kohm	5600pf
M-805A	40/80 AMPS	499kohm	3300pf
M-805B	55/110 AMPS	301kohm	4700pf
M-807A	55/110 AMPS	332kohm	3900pf
M-807C	30/60 AMPS	499kohm	3300pf

# APPENDIX H

## DRAWINGS

SERVOSTAR SP Series 3 & 6 Amp Drive Outline and Dimension Drawing .....	H-3
SERVOSTAR SP Series 10 Amp Drive Outline and Dimension Drawing .....	H-4
SERVOSTAR SP Series 20 Amp Drive Outline and Dimension Drawing .....	H-5
SERVOSTAR SP Series 30 Amp Drive Outline and Dimension Drawing .....	H-6
SERVOSTAR SP Series 55 Amp Drive Outline and Dimension Drawing .....	H-7
Power Supply PA08xx Outline and Dimension Drawing.....	H-8
Power Supply PA14xx and PA28xx Outline and Dimension Drawing.....	H-9
Power Supplies PA50xx, PA75xx, and PA85xx Outline and Dimension Drawing .....	H-10
Power Supply PA08xx Simplified Schematic Diagram .....	H-11
Power Supplies PA14xx and PA28xx Simplified Schematic Diagram.....	H-12
Power Supplies PA50xx, PA75xx, and PA85xx Simplified Schematic Diagram .....	H-13
SP1XXXX Simplified Schematic Diagram.....	H-14
SERVOSTAR SP Series System Wiring -- (Dwg. No. C-97514 - 11 Sheets).....	H-15



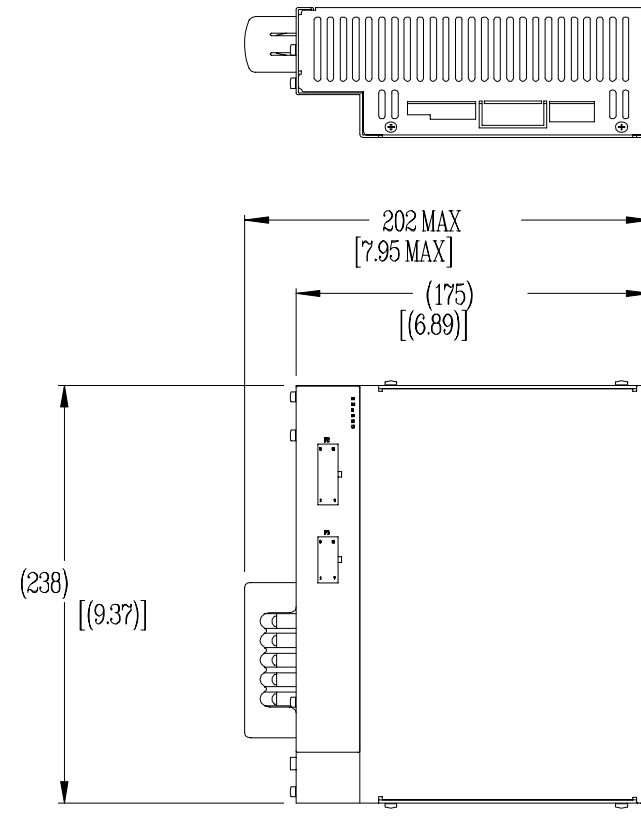
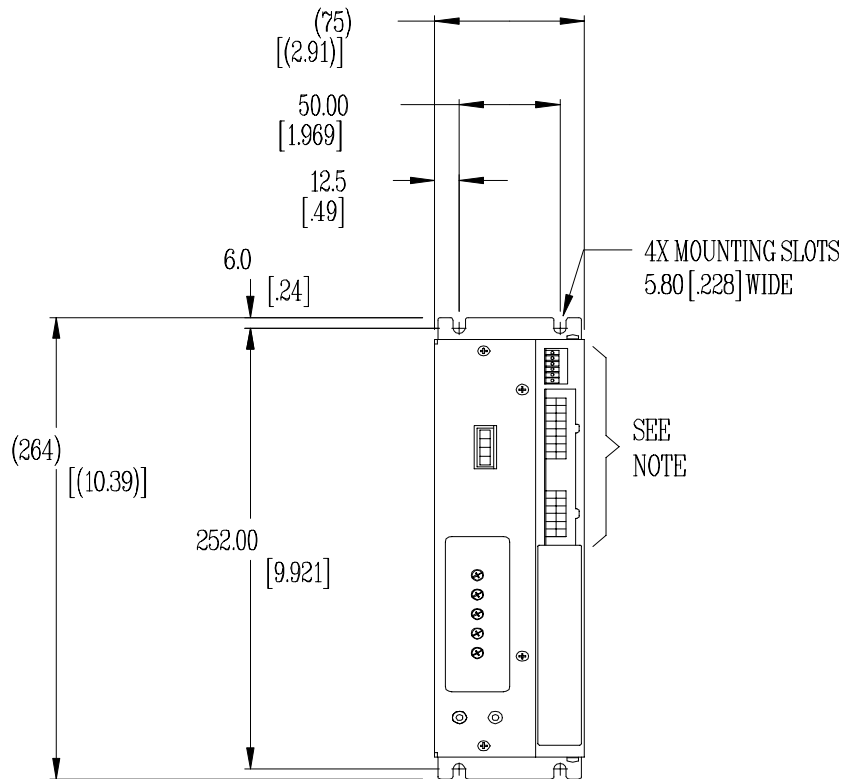

NOTE: CUSTOMER INTERFACE  
CONNECTIONS MAY VARY  
UPON VERSIONS.

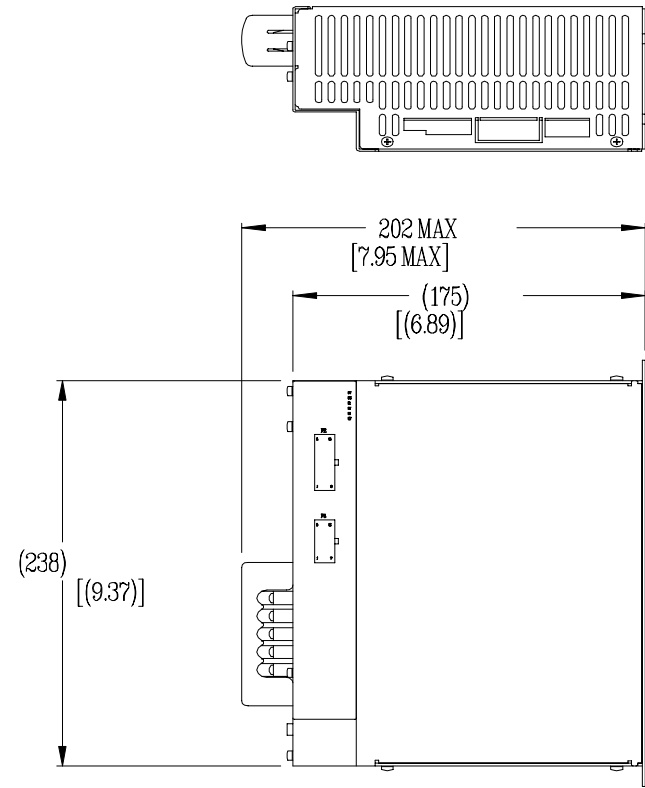
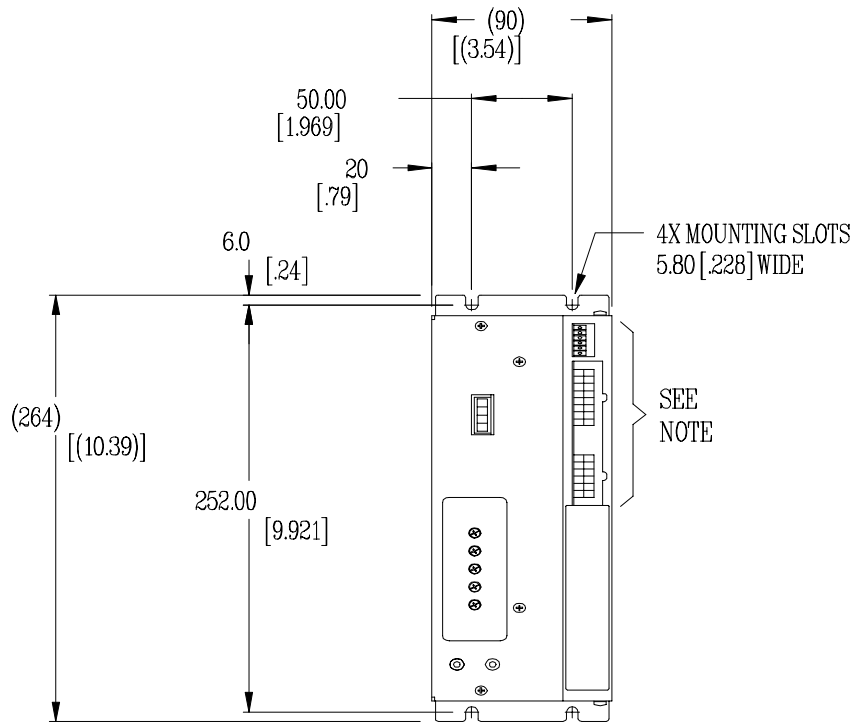

NOTE: CUSTOMER INTERFACE  
CONNECTIONS MAY VARY  
UPON VERSIONS.

OUTLINE  
10 AMP POWERSTAI

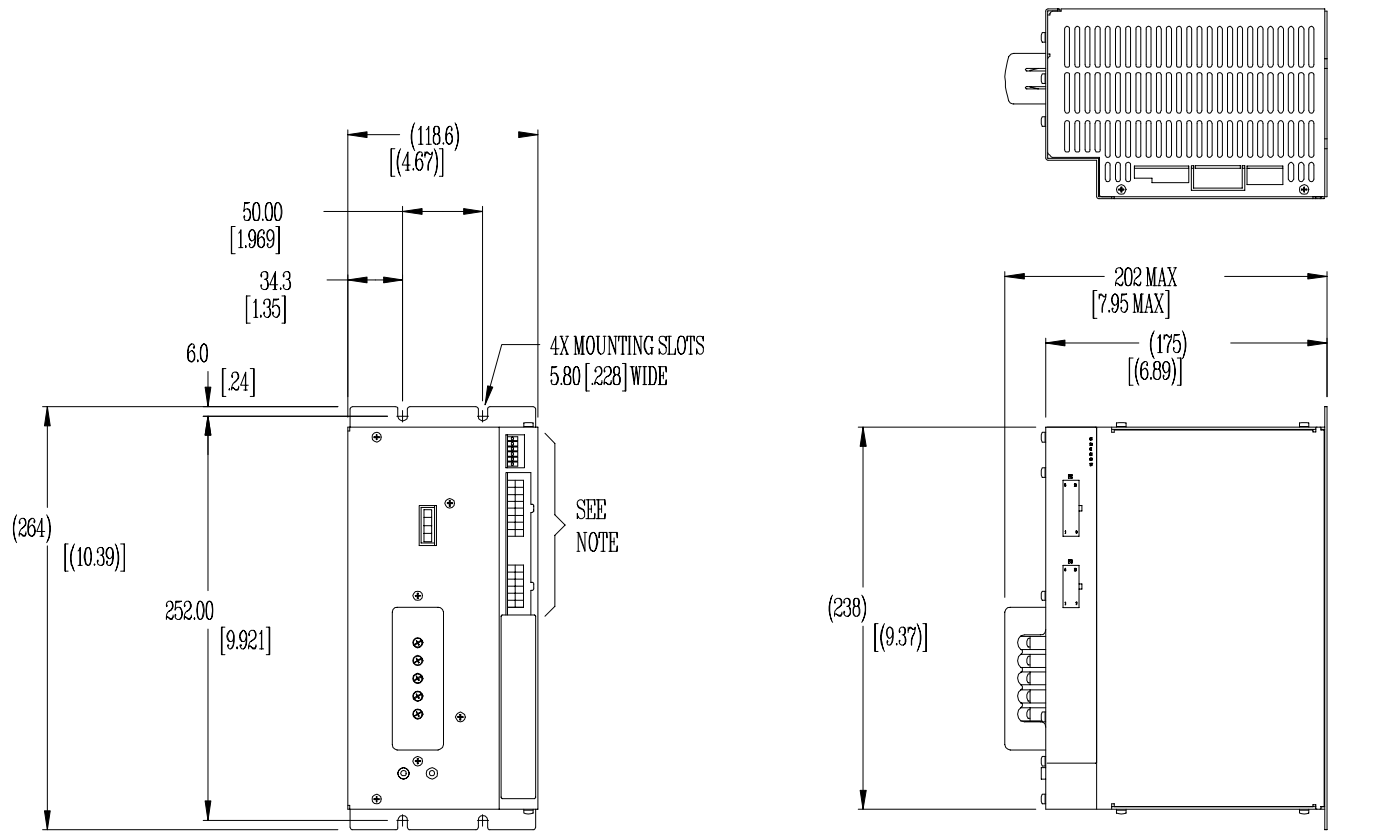

NOTE: CUSTOMER INTERFACE  
 CONNECTIONS MAY VARY  
 UPON VERSIONS.

OUTLINE  
 20 AMP POWERSTAR

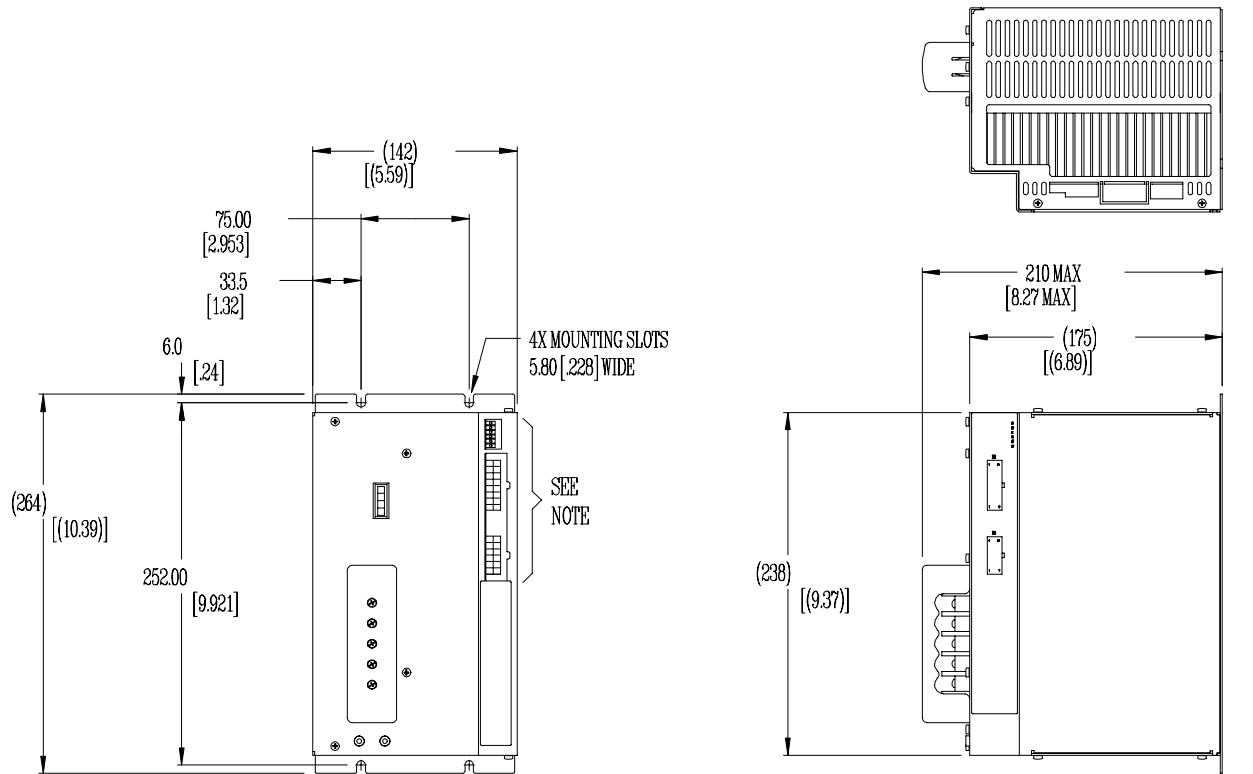

NOTE: CUSTOMER INTERFACE CONNECTIONS MAY VARY UPON VERSIONS.

OUTLINE  
30 AMP POWERSTAR

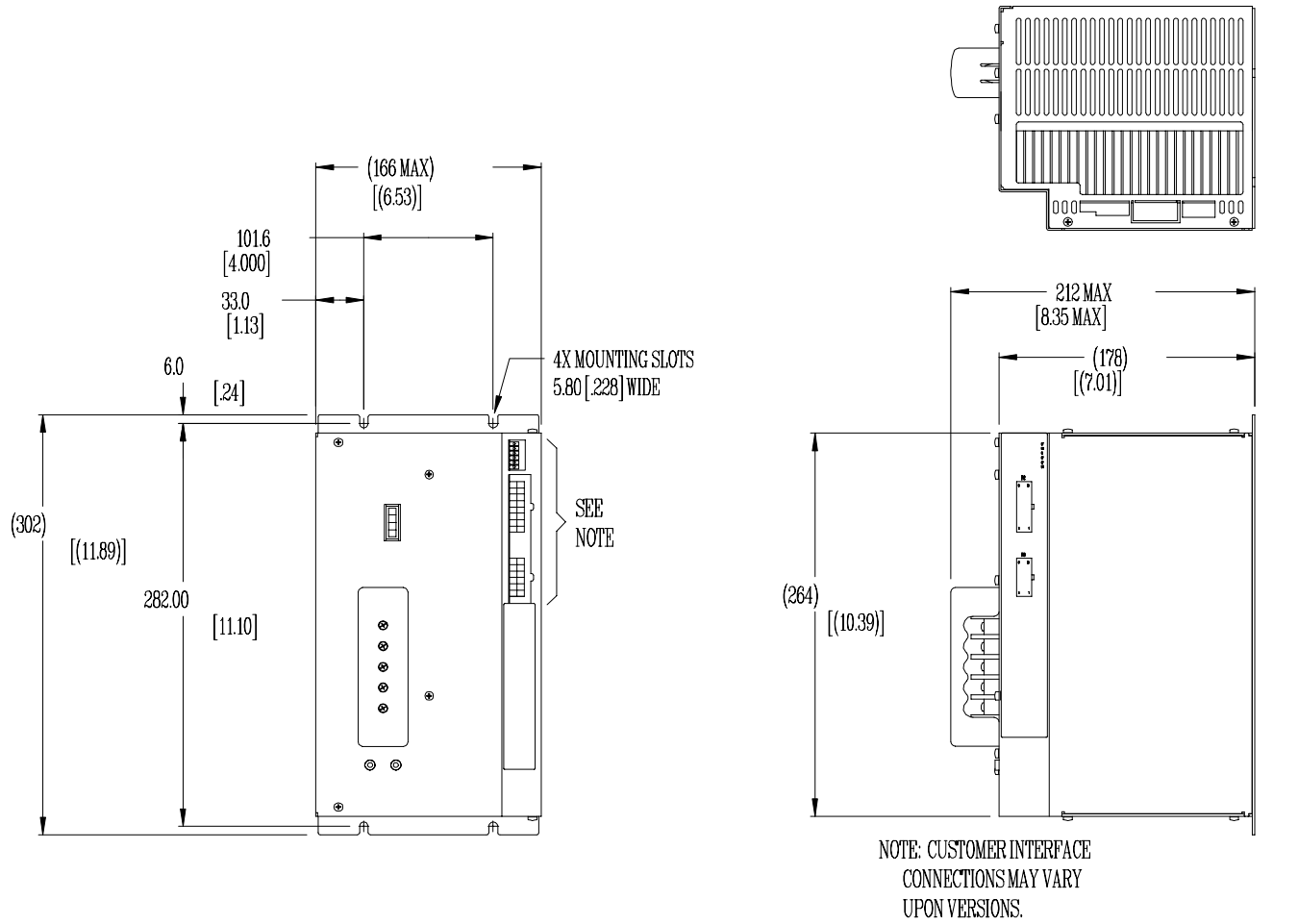

OUTLINE  
SP-55 AMP POWERSTAR

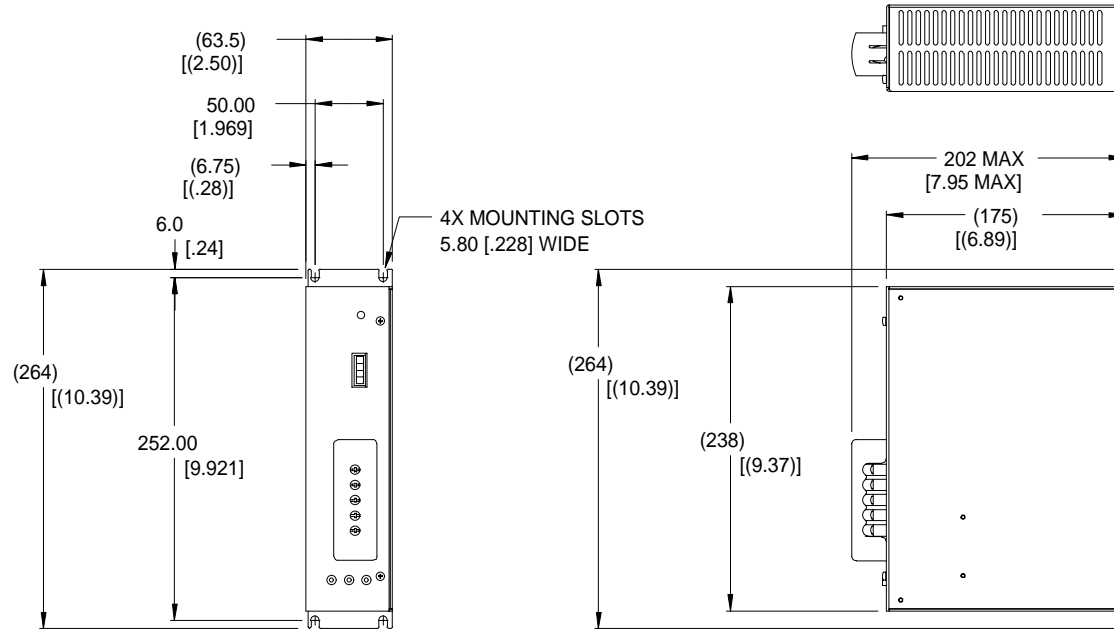

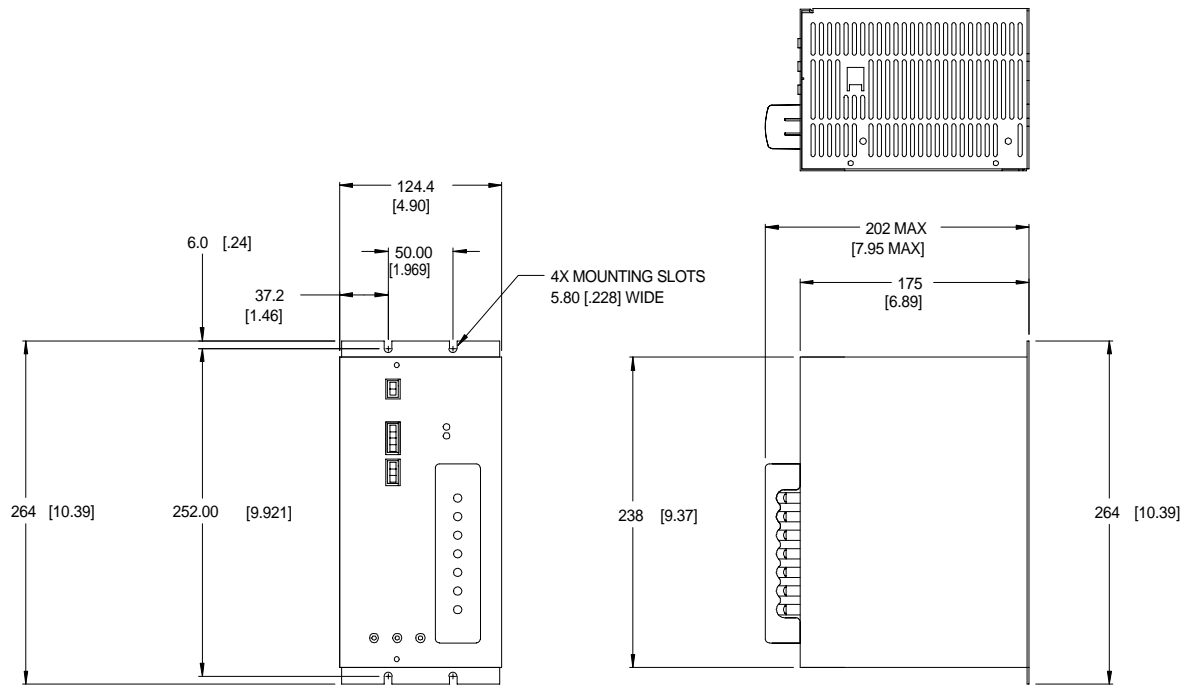

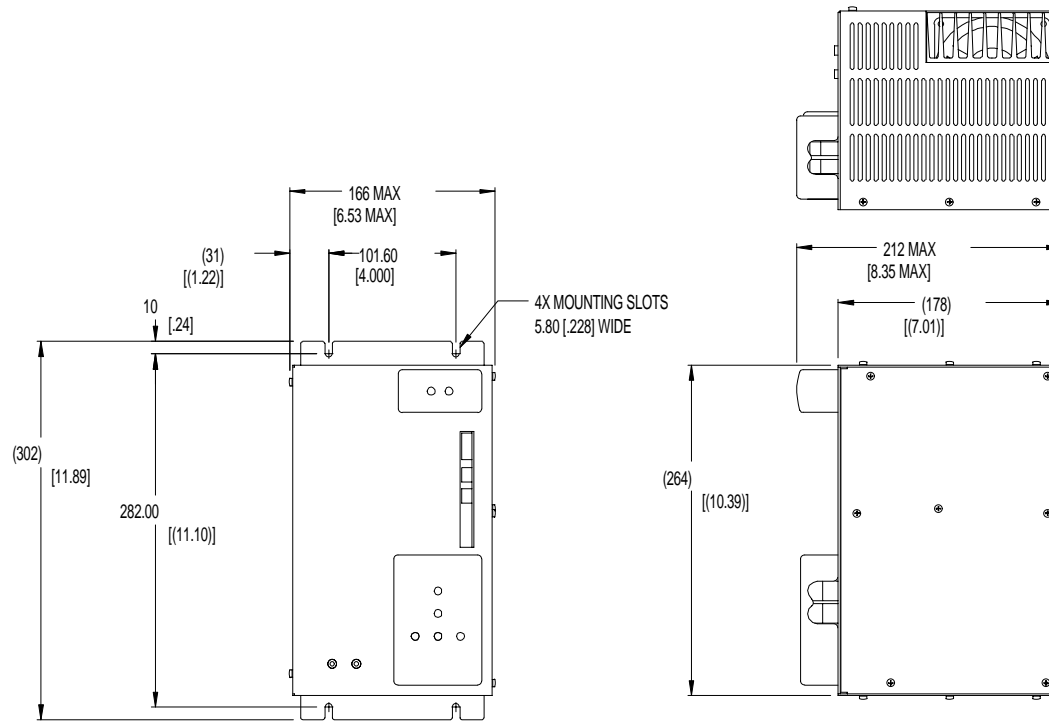

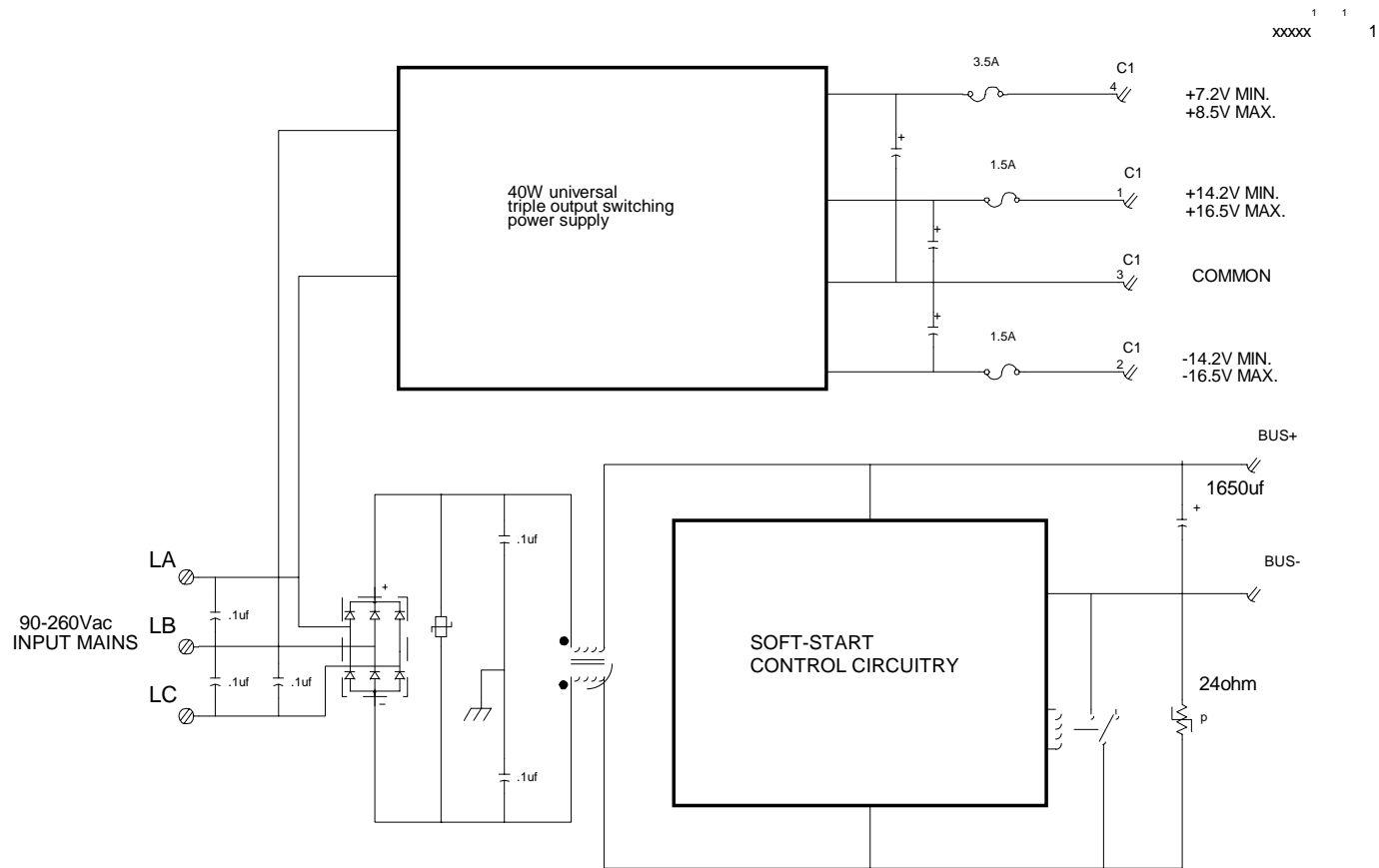

xxxxx 1 1 1

SIMPLIFIED SCHEMATIC FOR PA08

CJF 1/97

xxxxxx 1 1 1

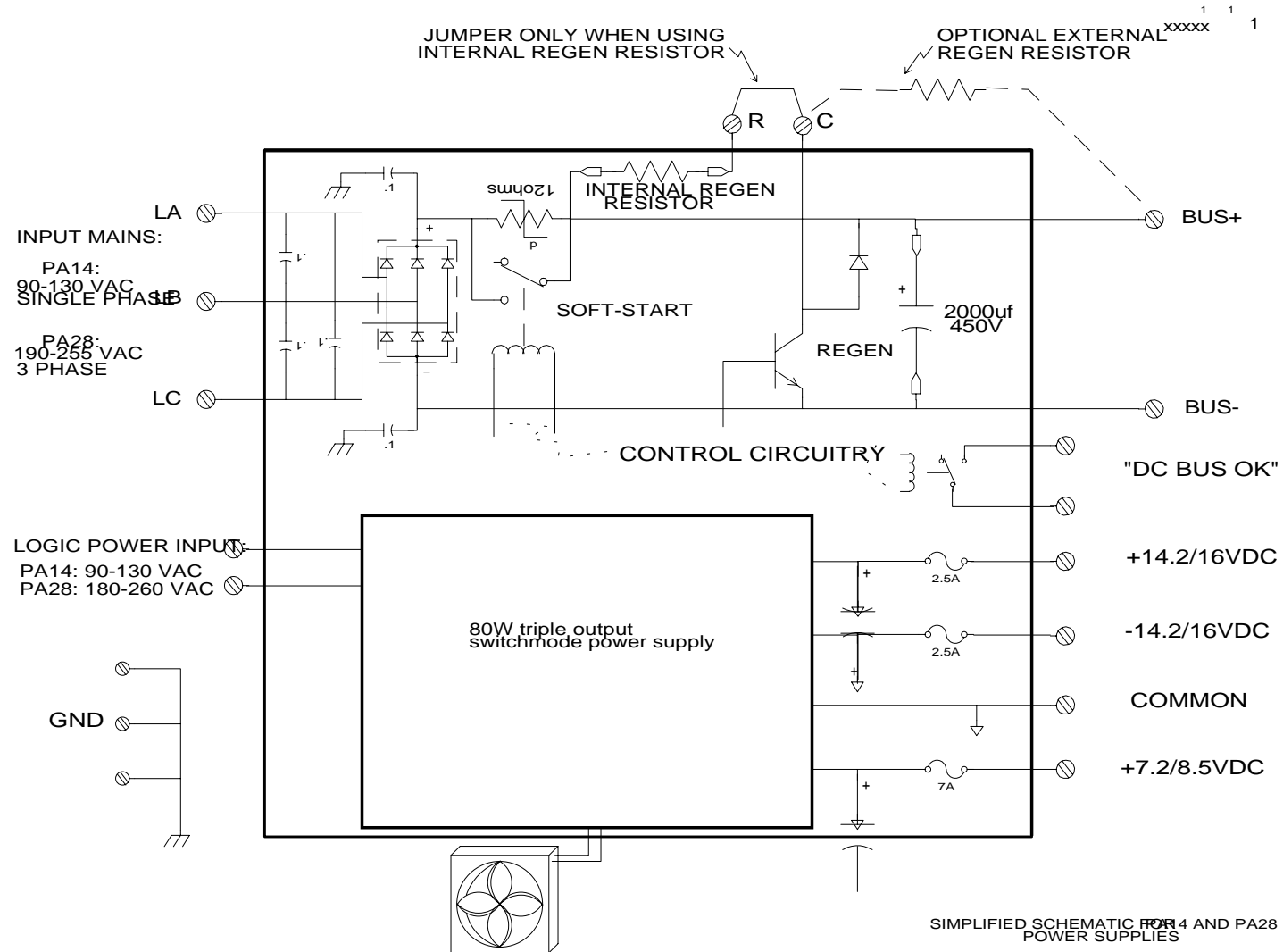

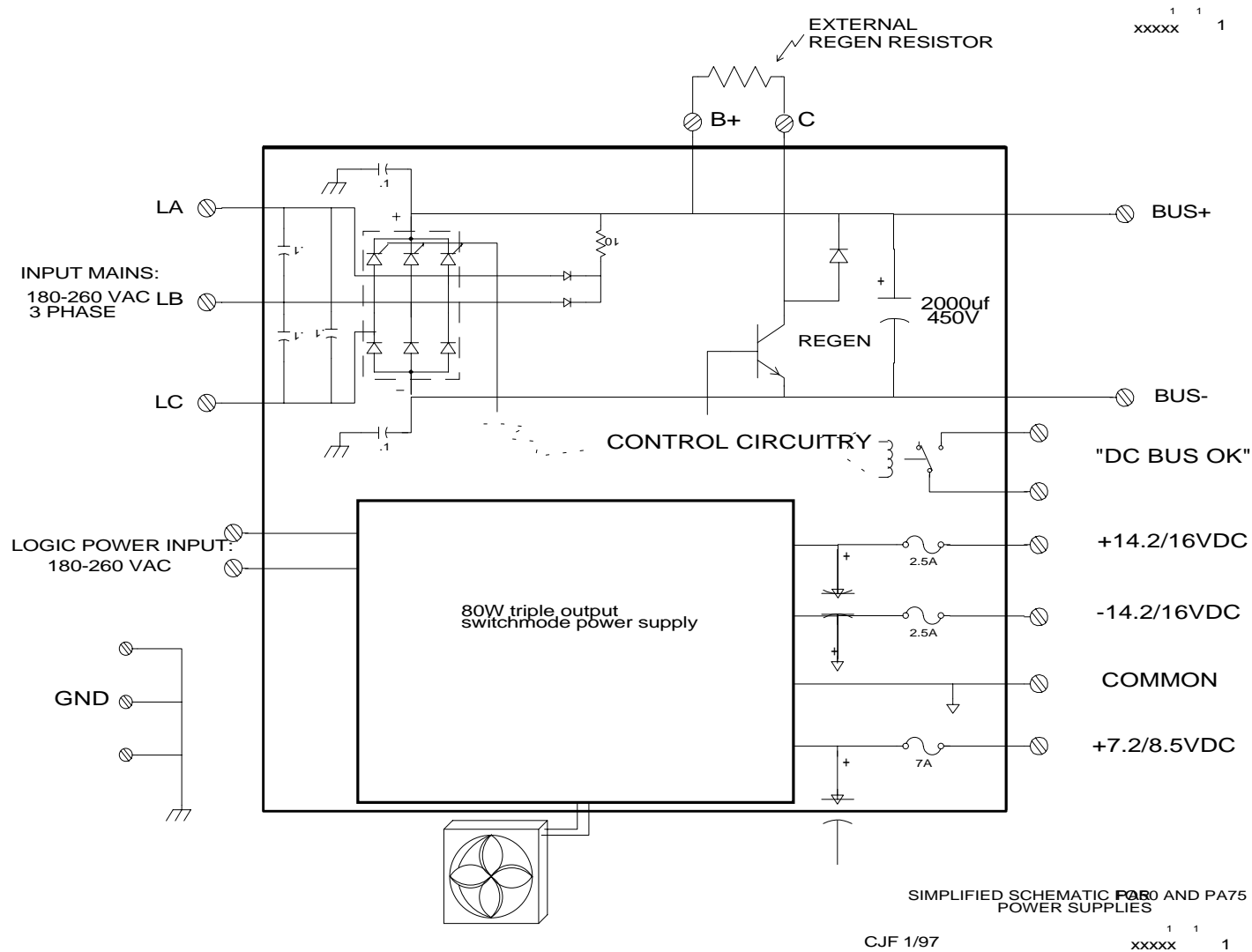

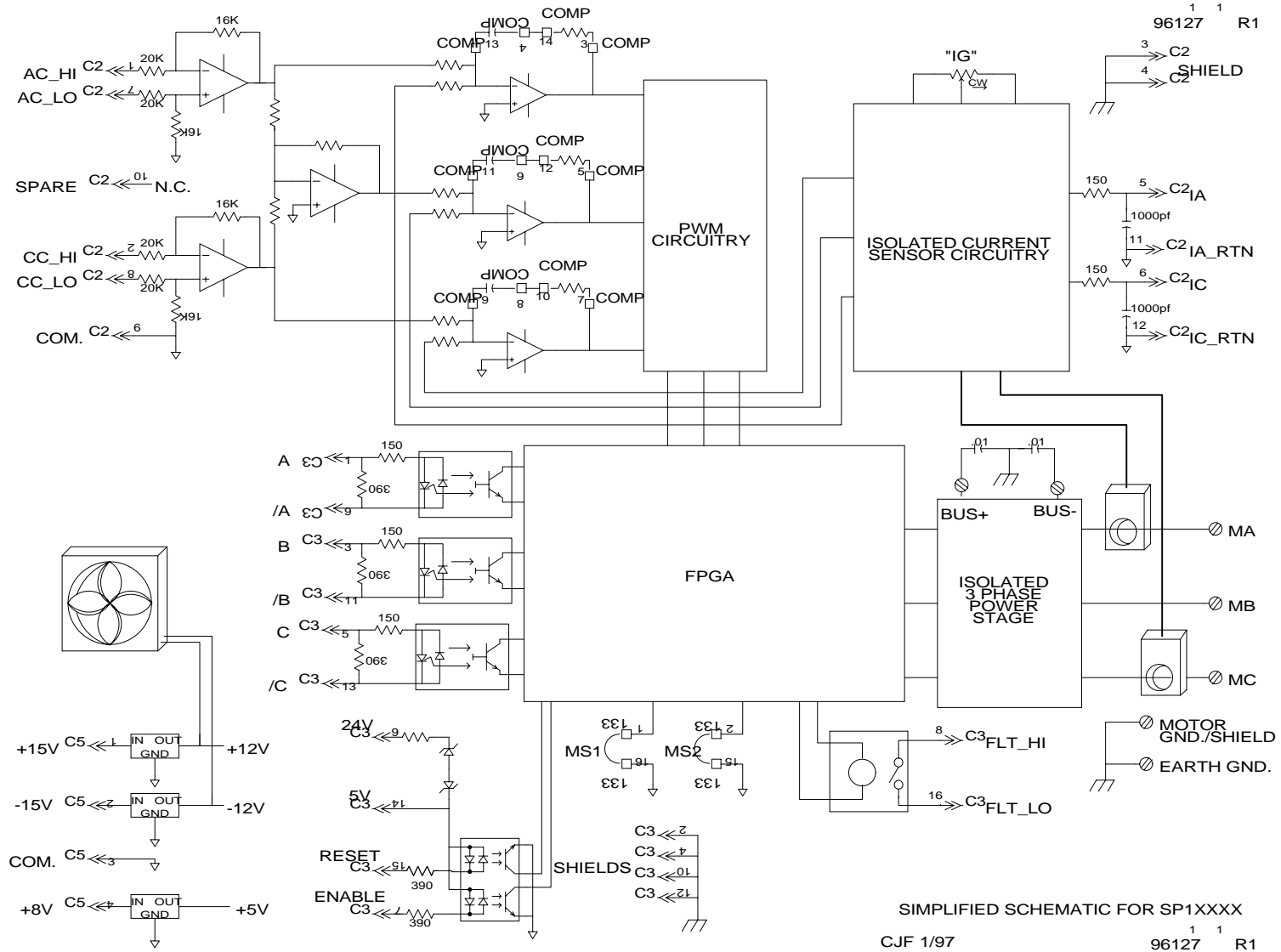

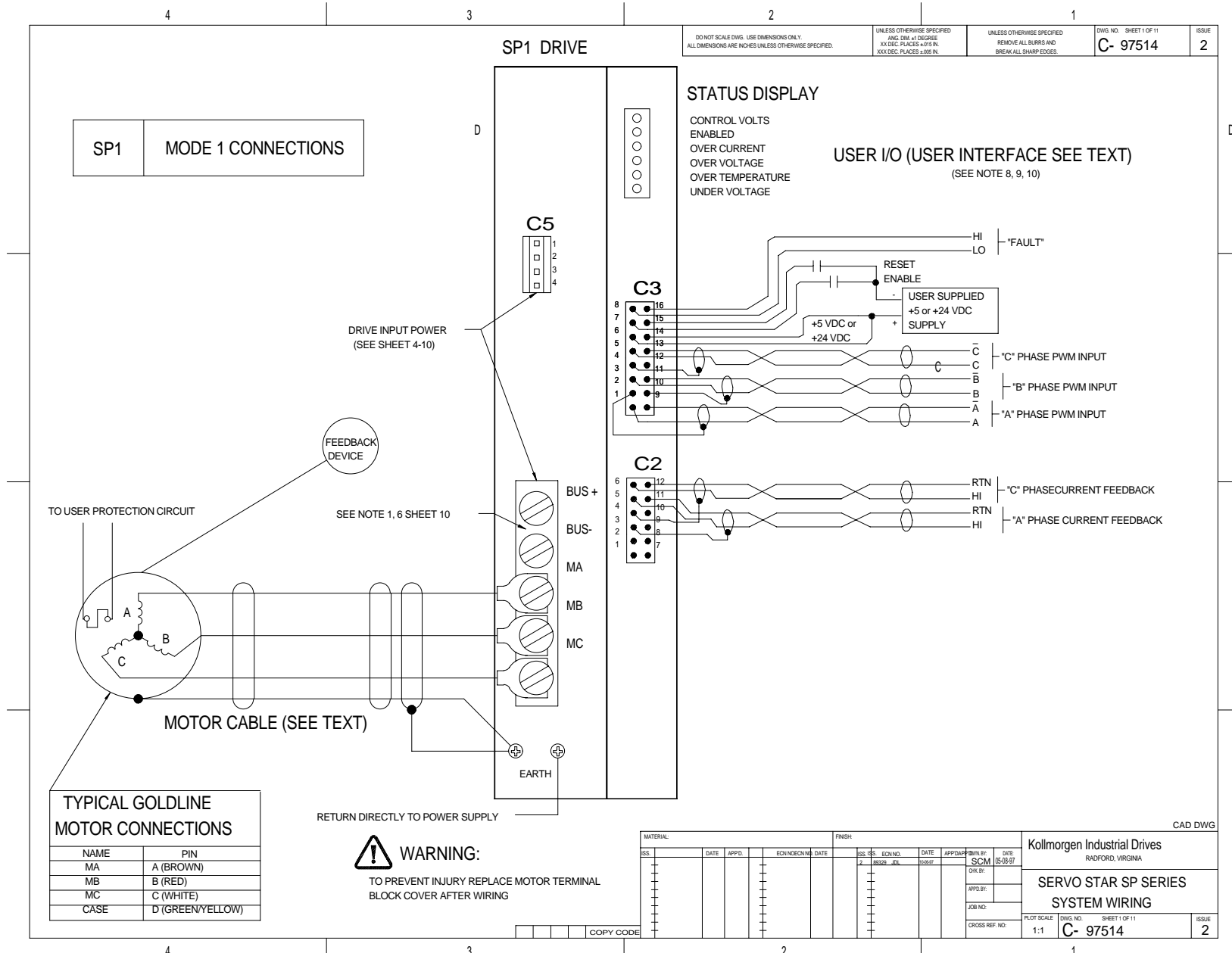

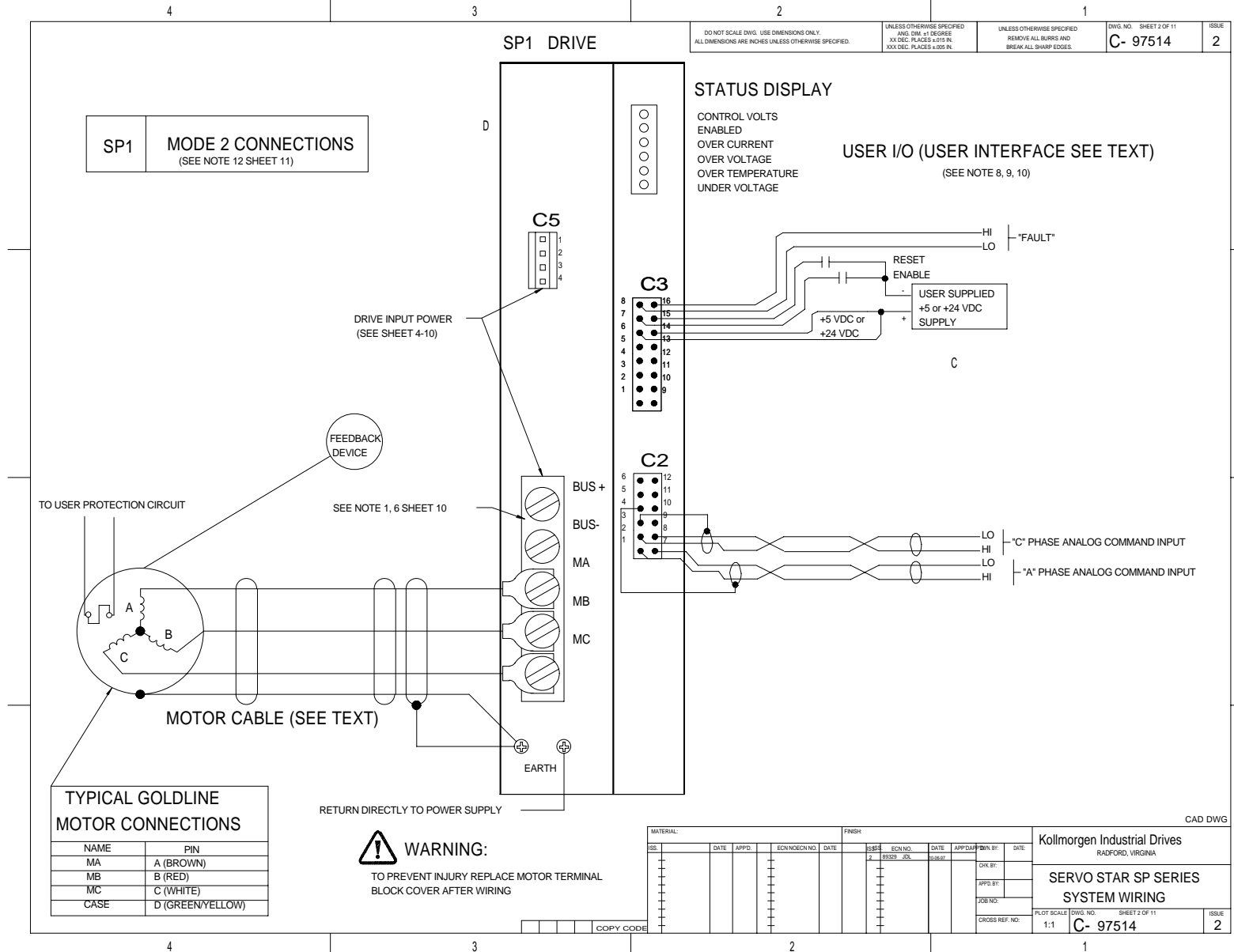

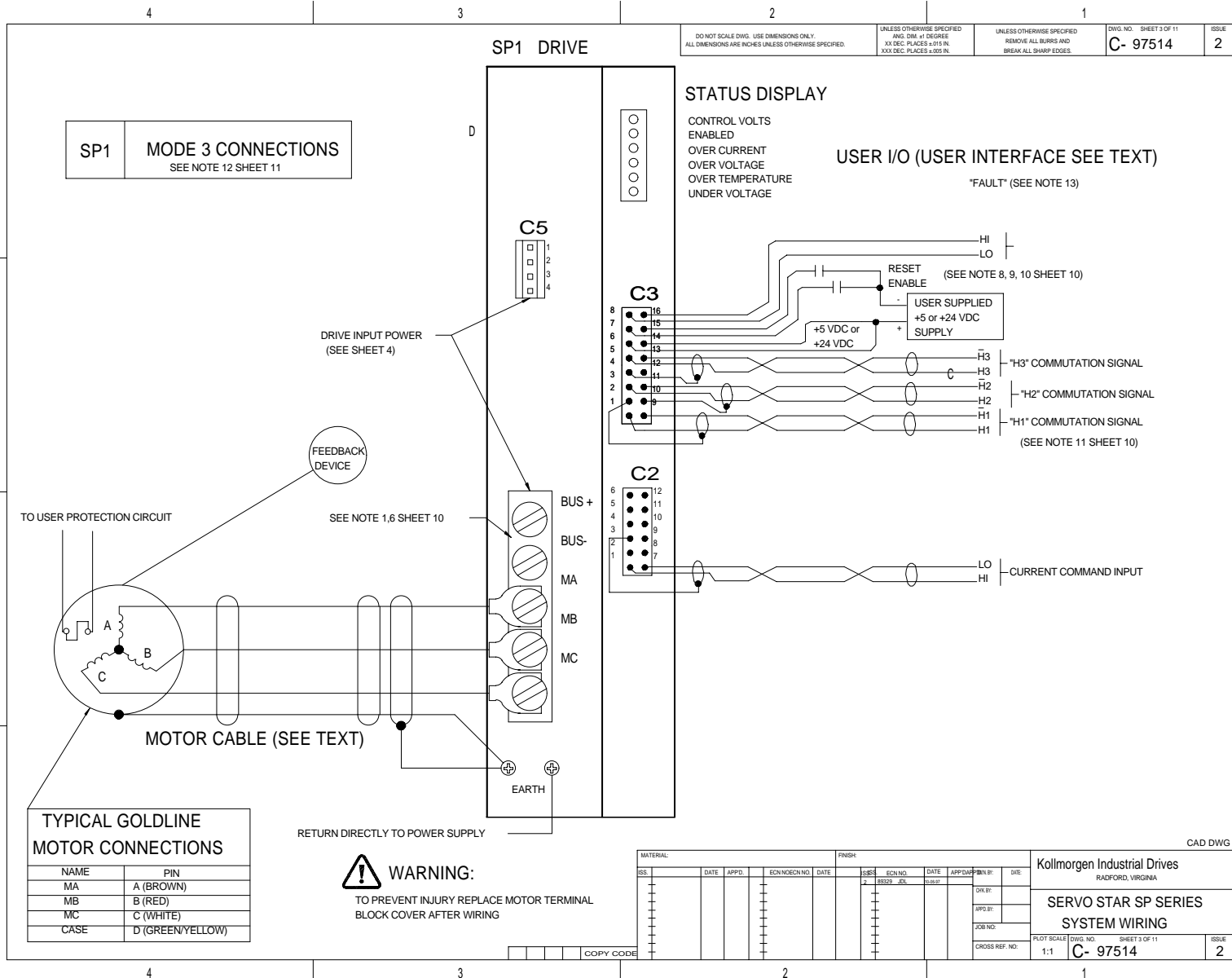

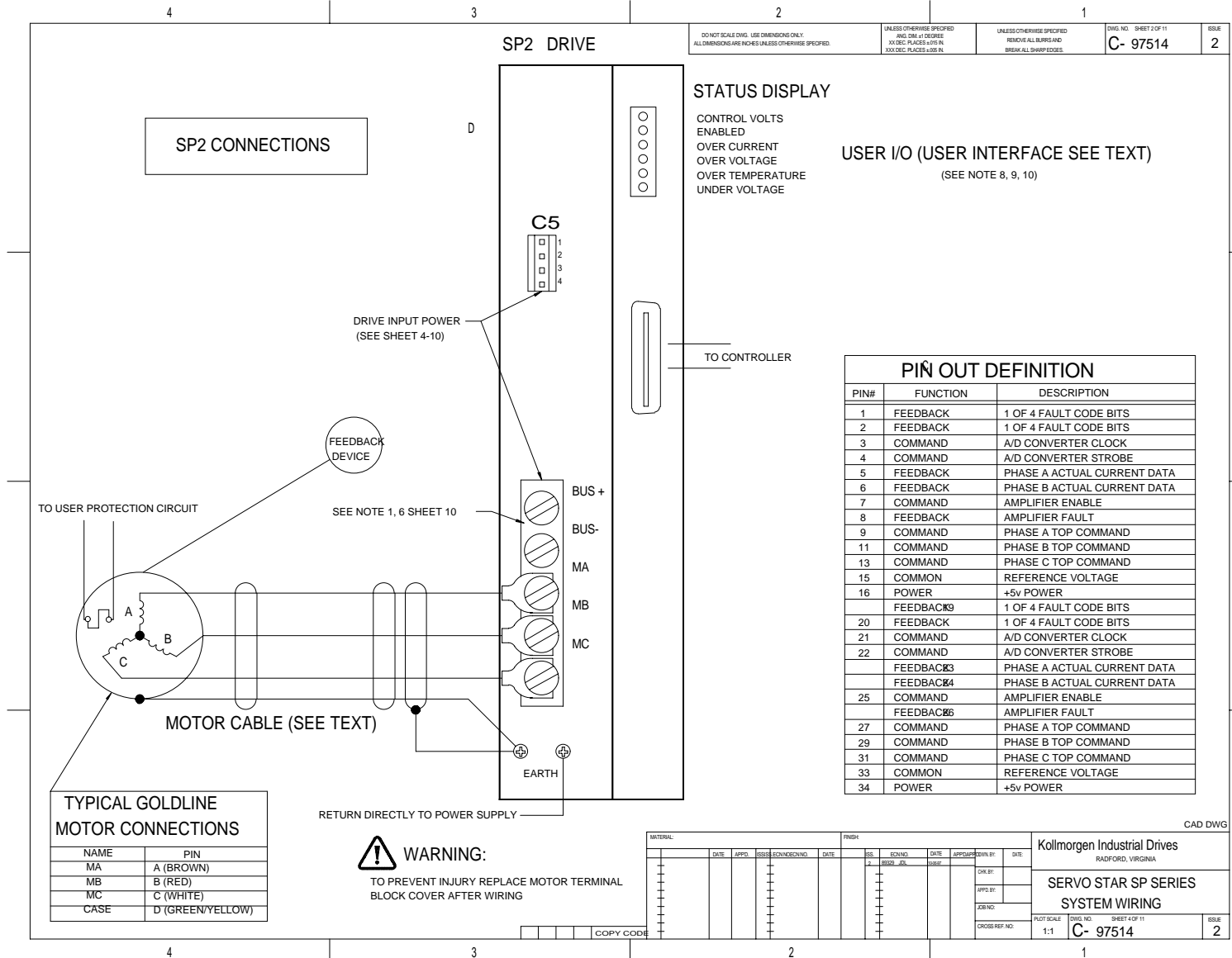





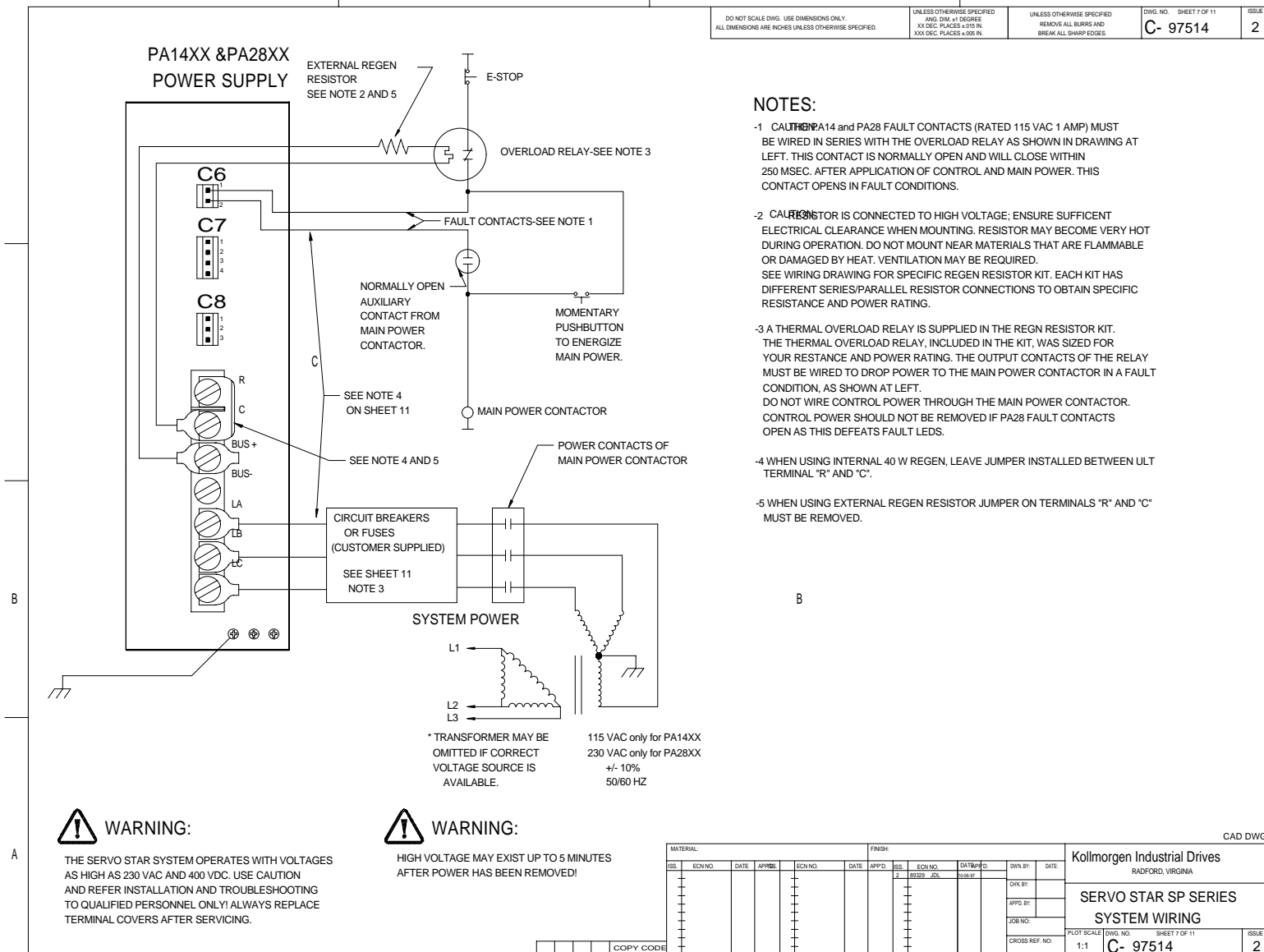



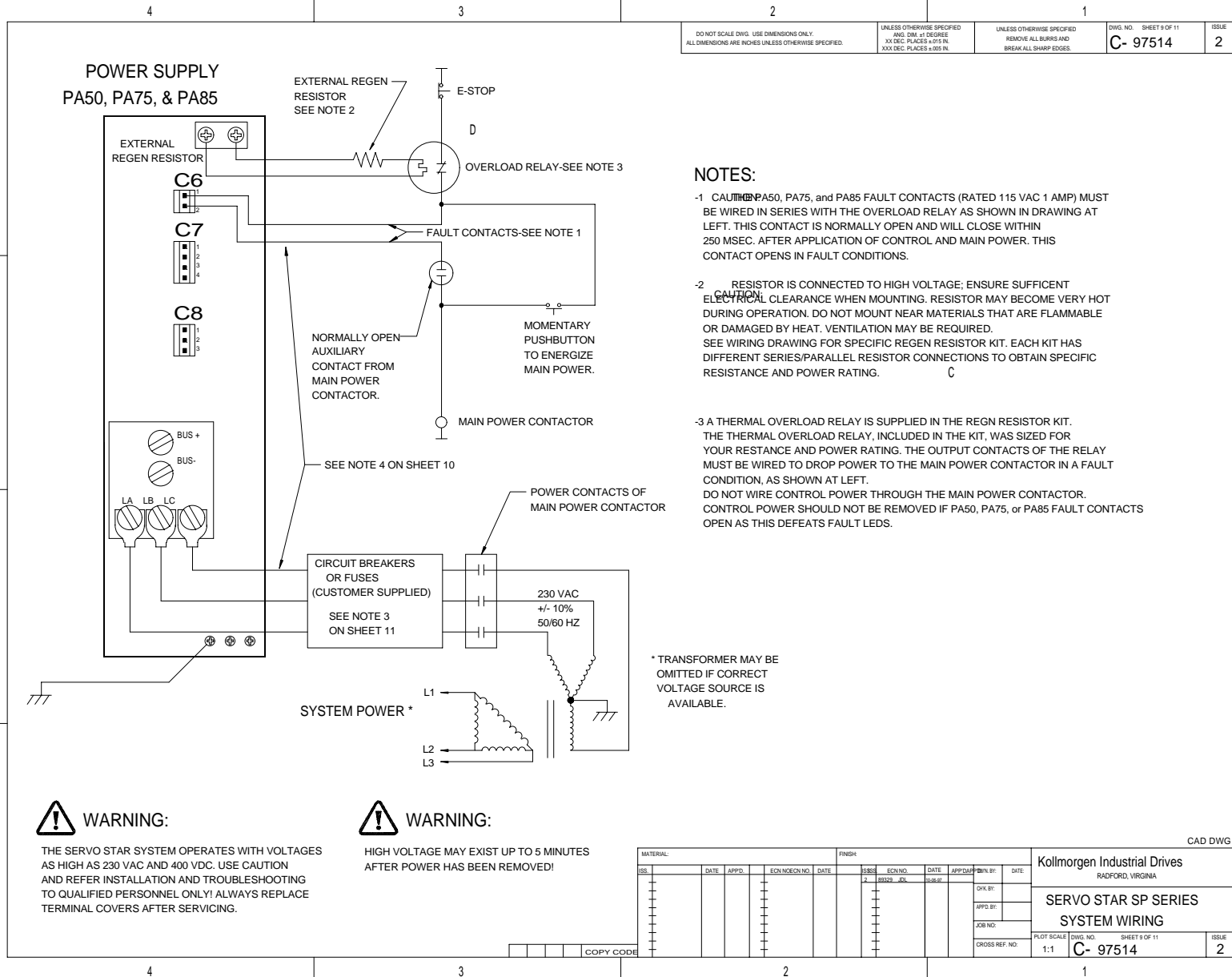

DO NOT SCALE DWG. USE DIMENSIONS ONLY.  
 ALL DIMENSIONS ARE INCHES UNLESS OTHERWISE SPECIFIED.

UNLESS OTHERWISE SPECIFIED  
 AND DIM. 1/2 DEGREE  
 XX DEC PLACES = 015 IN.  
 XXX DEC PLACES = 005 IN.

UNLESS OTHERWISE SPECIFIED  
 REMOVE ALL BURRS AND  
 BREAK ALL SHARP EDGES.

DWG. NO. SHEET 10 OF 11  
**C- 97514**

ISSUE  
**2**

LOGIC SUPPLY  
 PA-LM

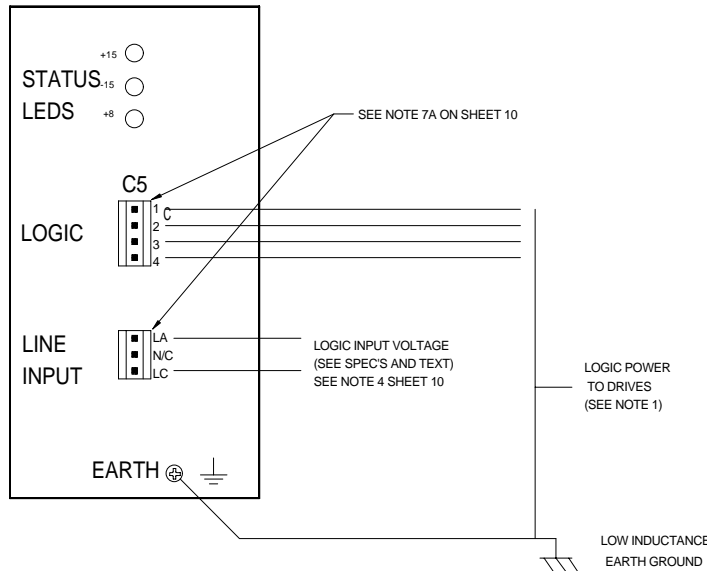

**C5 CONNECTIONS**

PIN	POWER SUPPLY	DRIVE
1	+15 VDC SUPPLY	+15 VDC INPUT
2	-15 VDC SUPPLY	-15 VDC INPUT
3	DC COMMON	DC COMMON
4	+8 VDC SUPPLY	+8 VDC INPUT

**LINE INPUT CONNECTIONS**

PIN	FUNCTION	NOTES
1	AC LOGIC POWER IN	SEE INSTALLATION
2	NOT USED	INSTRUCTIONS IN TEXT
3	AC LOGIC POWER IN	

**NOTES:**  
 CAUTION:  
 -1 UP TO 2 DRIVES TOTAL MAY BE MOUNTED TO EITHER SIDE OF POWER SUPPLY (SEE MANUAL) (SEE NOTE 5, SHEET 10).

**WARNING:**  
 THE SERVO STAR SYSTEM OPERATES WITH VOLTAGES AS HIGH AS 230 VAC AND 400 VDC. USE CAUTION AND REFER INSTALLATION AND TROUBLESHOOTING TO QUALIFIED PERSONNEL ONLY! ALWAYS REPLACE TERMINAL COVERS AFTER SERVICING.

**WARNING:**  
 HIGH VOLTAGE MAY EXIST UP TO 5 MINUTES AFTER POWER HAS BEEN REMOVED!

COPY CODE

MATERIAL:										FINISH:				Kollmorgen Industrial Drives RADFORD, VIRGINIA							
ISS.	ECN NO.	DATE	APPRD.	ECN NO.	DATE	APPRD.	SS.	ECN NO.	DATE	APPRD.	DATE	DWG. BY:	DATE	CHECKED BY:	DATE	JOB NO.	CROSS REF. NO.	PLOT SCALE	DWG. NO.	SHEET 10 OF 11	ISSUE
							2	89329	JDL	8/26/87								1:1	<b>C- 97514</b>		<b>2</b>

DO NOT SCALE DWG. USE DIMENSIONS ONLY. ALL DIMENSIONS ARE INCHES UNLESS OTHERWISE SPECIFIED.	UNLESS OTHERWISE SPECIFIED ANG. DIM. ±1 DEGREE XX DEC. PLACES ±0.01 IN. XXX DEC. PLACES ±0.001 IN.	UNLESS OTHERWISE SPECIFIED REMOVE ALL BURRS AND BREAK ALL SHARP EDGES.	DWG. NO. <b>C- 97514</b>	SHEET 11 OF 11 <b>2</b>
---	---	--	--------------------------	----------------------------

1. WARNING: ALWAYS REPLACE TERMINAL COVERS AFTER SERVICE OR INSTALLATION!

2. DRIVE AND POWER SUPPLY MUST BE INSTALLED IN AN ENCLOSURE (VENTILATION OR COOLING MAY BE NECESSARY TO PREVENT ENCLOSURE AMBIENT FROM EXCEEDING 45°C).

3. WIRE SIZES, BREAKERS AND FUSES FOR SERVOSTAR.

PA08 HAS A MAXIMUM MAIN POWER INPUT CURRENT OF 8 AMPS RMS. FUSE FOR 10 AMPS (FRN-10 OR EQUIVALENT).

PA14 HAS A MAXIMUM MAIN POWER INPUT CURRENT OF 14 AMPS RMS. FUSE FOR 20 AMPS (FRN-20 OR EQUIVALENT).

PA28 HAS A MAXIMUM MAIN POWER INPUT CURRENT OF 28 AMPS RMS. FUSE FOR 35 AMPS (FRN-35 OR EQUIVALENT).

PA50 HAS A MAXIMUM MAIN POWER INPUT CURRENT OF 50 AMPS RMS. FUSE FOR 60 AMPS (FRN-60 OR EQUIVALENT).

PA75 HAS A MAXIMUM MAIN POWER INPUT CURRENT OF 75 AMPS RMS. FUSE FOR 80 AMPS (FRN-80 OR EQUIVALENT).

PA85 HAS A MAXIMUM MAIN POWER INPUT CURRENT OF 85 AMPS RMS. FUSE FOR 100 AMPS (FRN-100 OR EQUIVALENT).

THE ACTUAL APPLICATION MAY REQUIRE LESS CURRENT, USE 600V VAC INSULATED WIRE AND REFER TO LOCAL ELECTRICAL CODES FOR PROPER WIRE SIZE FOR THE CURRENTS LISTED ABOVE. FUSES FOR MAIN POWER SHOULD BE A UL RATED TIME DELAY TYPE, SUCH AS BUSS FRN-RSERIES. CONTROLS CIRCUITS SHALL BE PROVIDED WITH APPROPRIATE OVER-CURRENT PROTECTION.

THE POWER BUS BETWEEN POWER SUPPLIES (PA08, PA14, PA28, PA50, PA75, AND PA85) AND DRIVES SHOULD USE THE FOLLOWING MINIMUM WIRE GAUGE WITH 600 VAC INSULATION. USE ONLY COPPER WIRE. WIRE SIZE MAY BE DETERMINED FROM TABLE 310-16 OF THE NEC 60° OR 75° COLUMN.

RECOMMENDED WIRE GAUGE POWER SUPPLIES

PA08, 14 AWG OR LARGER WIRE

PA14, 14 AWG OR LARGER WIRE

PA28, 10 AWG OR LARGER WIRE

PA50, 6 AWG OR LARGER WIRE

PA75, 4 AWG OR LARGER WIRE

PA85, 1 AWG OR LARGER WIRE

RECOMMENDED WIRE GAUGE DRIVES

SX03, 14 AWG OR LARGER WIRE

SX06, 14 AWG OR LARGER WIRE

SX10, 14 AWG OR LARGER WIRE

SX20, 10 AWG OR LARGER WIRE

SX30, 10 AWG OR LARGER WIRE

SX55, 6 AWG OR LARGER WIRE

RECOMMENDED SPADE TERMINALS

16/14 AWG HOLLINGSWORTH XSS20954S OR SS20947SF

12/10 AWG HOLLINGSWORTH XSS20836 OR SS20832F

RECOMMENDED RING TERMINALS

8 AWG HOLLINGSWORTH R3027BF

6 AWG HOLLINGSWORTH R4001BF

4 AWG HOLLINGSWORTH R5100BF

4. ALL AC LINES SHOULD BE TWISTED CABLES.

5. THE TOTAL NUMBER OF AXES ALLOWED PER POWER SUPPLY DEPENDS ON THE APPLICATION AND THE COMBINATION OF DRIVES REQUIRED POWER.

PA-LM A MAXIMUM OF 2 DRIVES (SEE SPECIFICATIONS OF POWER SUPPLY AND REQUIREMENTS OF DRIVE) DO NOT EXCEED LOGIC SUPPLY CAPACITY!

PA08: A MAXIMUM OF 2 DRIVES (SEE SPECIFICATIONS OF POWER SUPPLY AND REQUIREMENTS OF DRIVE) DO NOT EXCEED LOGIC SUPPLY CAPACITY!

PA14: A MAXIMUM OF 4 DRIVES (SEE SPECIFICATIONS OF POWER SUPPLY AND REQUIREMENTS OF DRIVE) DO NOT EXCEED LOGIC SUPPLY CAPACITY!

PA28: A MAXIMUM OF 4 DRIVES (SEE SPECIFICATIONS OF POWER SUPPLY AND REQUIREMENTS OF DRIVE) DO NOT EXCEED LOGIC SUPPLY CAPACITY!

PA50: A MAXIMUM OF 4 DRIVES (SEE SPECIFICATIONS OF POWER SUPPLY AND REQUIREMENTS OF DRIVE) DO NOT EXCEED LOGIC SUPPLY CAPACITY!

PA75: A MAXIMUM OF 4 DRIVES (SEE SPECIFICATIONS OF POWER SUPPLY AND REQUIREMENTS OF DRIVE) DO NOT EXCEED LOGIC SUPPLY CAPACITY!

PA85: A MAXIMUM OF 4 DRIVES (SEE SPECIFICATIONS OF POWER SUPPLY AND REQUIREMENTS OF DRIVE) DO NOT EXCEED LOGIC SUPPLY CAPACITY!

6. THE SX03, SX06, SX10, SX20 AND PA08 POWER TERMINAL BLOCKS INCORPORATE CAPTIVE SCREWS. DO NOT ATTEMPT TO REMOVE THEM FOR USE WITH RING TERMINALS. USE LOCKING SPRING SPADE TERMINALS SUCH AS HOLLINGSWORTH #XSS20954S OR #SS20947SF FOR 16/14 AWG WIRE AND #XSS20836 OR #SS20832F FOR 12/10 AWG WIRE.

7. RECOMMENDED TORQUES ARE

A) CONTROL SIGNALS 2.25 IN-LB

B) SX03, SX06, SX10, SX20, PA08, PA14, AND PA28  
 MAX TORQUE 12 IN-LB: MOTOR, BUS CONNECTION AND GROUND STUD

C) SX30, SX55, PA50, PA75, AND PA85  
 MAX TORQUE 20 IN-LB: MOTOR, BUS CONNECTION AND GROUND STUD

8. ALL SIGNAL AND CONTROL WIRES TO BE 22-18 AWG. THE CRIMP TERMINALS ARE SUPPLIED IN THE CONNECTOR KITS. IF 16 AWG WIRE IS USED, ORDER MOLEX TERMINALS #39-00-0078. SHIELDED CABLES RECOMMENDED. REFER TO MANUAL FOR SIGNAL DESCRIPTIONS AND REQUIREMENTS.

9. SHIELDING OF SIGNAL CABLES OFTEN PROVIDES BEST PERFORMANCE WHEN SHIELDS ARE TIED ONLY AT SOURCE END.

10. REFER TO MANUAL FOR SIGNAL SPECIFICATIONS.

11. COMMUTATION SIGNAL FROM ENCODER'S COMMUTATION TRACKS OR HALL EFFECT SENSORS. MAY BE DRIVEN DIFFERENTIALLY AS SHOWN, OR SINGLE ENDED INPUTS ON HX AND HX CONNECTED TO SENSOR'S +5VDC SUPPLY.

12. OPERATION MODES 2 AND 3 REQUIRE COMPENSATION COMPONENTS INSTALLED IN HEADER LOCATION "COMP". SEE MANUAL FOR DETAILS.

MATERIAL										FINISH		
ISS.	ECN NO.	DATE	APPROV.	ECN NO.	DATE	APPROV.	ISS.	ECN NO.	DATE	APPROV.	DRAWN BY	DATE

CAD DWG

**Kollmorgen Industrial Drives**  
 RADFORD, VIRGINIA

**SERVO STAR SP SERIES**  
**SYSTEM WIRING**

PLOT SCALE 1:1  
 DWG. NO. **C- 97514**  
 SHEET 11 OF 11  
 ISSUE **2**

COPY CODE



## **GLOSSARY**

### **Acceleration**

The change in velocity as a function of time. Acceleration usually refers to increasing velocity and deceleration describes decreasing velocity.

### **Ambient Temperature**

The temperature of the cooling medium, usually air, immediately surrounding the motor or another device.

### **Amplifier**

Electronics which convert low level command signals to high power voltages and currents to operate a servo motor.

### **Brushless Servo Drive**

A servo drive used to control a permanent magnet synchronous AC motor. May also be referred to as an AC Servo Drive.

### **Drive**

This is the electronics portion of the system that controls power to the motor.

### **Drive, Analog**

Usually referring to any type of motor drive in which the input is an analog signal.

### **Drive, Servo**

A motor drive which utilizes internal feedback loops for accurate control of motor current and/or velocity.

### **Efficiency**

The ratio of output power to input power.

### **Encoder, Absolute**

A digital position transducer in which the output is representative of the absolute position of the input shaft within one (or more) revolutions. Output is usually a parallel digital word.

### **Encoder, Incremental**

A position encoding device in which the output represents incremental changes in position.

### **Encoder, Marker**

A once-per-revolution signal provided by some incremental encoders to specify a reference point within that revolution. Also known as Zero Reference signal or index pulse.

### **Encoder Resolution**

A measure of the smallest positional change which can be detected by the encoder.

### **Feedback**

A signal which is transferred from the output back to the input for use in a closed loop system.

### **Following Error**

The position error during motion resulting from use of a position control loop with proportional gain only.

### **Friction**

A resistance to motion caused by surfaces rubbing together. Friction can be constant with varying speed (coulomb friction) or proportional to speed (viscous friction) or present at rest (static friction).

### **Full Load Current**

The armature current of a motor operated at its full load torque and speed with rated voltage applied.

### **Full Load Speed**

The speed of a motor operated with rated voltage and full load torque.

### **Gain**

The ratio of system output signal to system input signal. The control loop parameter that determines system performance characteristics.

### **HP: Horsepower**

One horsepower is equal to 746 watts. Since  $\text{Power} = \text{Torque} \times \text{Speed}$ , horsepower is a measure of a motor's torque and speed capability (e.g. a 1 HP motor will produce 35 lb-in. at 1800 rpm).

**I/O: Input/Output**

The reception and transmission of information between control devices. In modern control systems, I/O has two distinct forms: switches, relays, etc., which are in either an on or off state, or analog signals that are continuous in nature such as speed, temperature, flow, etc.

**Inertia**

The property of an object to resist changes in velocity unless acted upon by an outside force. Higher inertia objects require larger torques to accelerate and decelerate. Inertia is dependent upon the mass and shape of the object.

**Inertial Match**

An inertial match between motor and load is obtained by selecting the coupling ratio such that the load moment of inertia referred to the motor shaft is equal to the motor moment of inertia.

**Inrush Current**

The current surge generated when a piece of equipment such as a servo amplifier is connected to an AC line. This surge is typically due to the impulse charging of a large capacitor located in the equipment.

**Instability**

Undesirable motion of an actuator that is different from the command motion. Instability can take the form of irregular speed or hunting of the final rest position.

**Limits**

Motion control systems may have sensors called limits that alert the control electronics that the physical end of travel is being approached and that motion should stop.

**Logic Ground**

An electrical potential to which all control signals in a particular system are referenced.

**Loop, Feedback Control**

A control method that compares the input from a measurement device, such as an encoder or tachometer, to a desired parameter, such as a position or velocity and causes action to correct any detected

error. Several types of loops can be used in combination (i.e. velocity and position together) for high performance requirements.

**Master Slave Motion Control**

A type of coordinated motion control where the master axis position is used to generate one or more slave axis position commands.

**Motor, AC**

A device that converts electrical alternating current into mechanical energy. Requires no commutation devices such as brushes. Normally operated off commercial AC power. Can be single or multiple phase.

**Oscillation**

An effect that varies periodically between two values.

**PLC**

Programmable Logic Controller. Also known as a programmable controller, these devices are used for machine control and sequencing.

**Power**

The rate at which work is done. In motion control,  $\text{Power} = \text{Torque} \times \text{Speed}$ .

**Pulse Rate**

The frequency of the step pulses applied to a step-per motor driver. The pulse rate divided by the resolution of the motor/drive combination (in steps per revolution) yields the rotational speed in revolutions per second.

**Ramping**

The acceleration and deceleration of a motor. May also refer to the change in frequency of the applied step pulse train.

**Rated Torque**

The torque producing capacity of a motor at a given speed. This is the maximum continuous torque the motor can deliver to a load and is usually specified with a torque/speed curve.

**Regeneration**

The action during motor braking, in which the motor acts as a generator and takes kinetic energy from the load, converts it to electrical energy, and returns it to the amplifier.

**Repeatability**

The degree to which the positioning accuracy for a given move performed repetitively can be duplicated.

**Resolution**

The smallest positioning increment that can be achieved. Frequently defined as the number of steps or feedback units required for a motor's shaft to rotate one complete revolution.

**Resolver**

A position transducer utilizing magnetic coupling to measure absolute shaft position over one revolution.

**RMS Current**

Root mean square current. In an intermittent duty cycle application, the RMS current is equal to the value of steady state current which would produce the equivalent resistive heating over a long period of time.

**Rotor**

The rotating part of a magnetic structure. In a motor, the rotor is connected to the motor shaft.

**Servo Amplifier/Servo Drive**

An electronic device which produces the winding current for a servo motor. The amplifier converts a low level control signal into high voltage and current levels to produce torque in the motor.

**Servo System**

An automatic feedback control system for mechanical motion in which the controlled or output quantity is position, velocity, or acceleration. Servo systems are closed loop systems.

**Shunt Resistor**

A device located in a servo amplifier for controlling regenerative energy generated when braking a motor. This device dissipates or "dumps" the kinetic energy as heat.

**Single Point Ground**

The common connection point for signal grounds in a control wiring environment.

**Slew**

In motion control the portion of a move made at a constant non-zero velocity.

**Speed Regulation**

For a speed control system, speed regulation is the variation in actual speed expressed as a percentage of set speed.

**Stiffness**

Ratio of an applied force torque to change in position for a mechanical system.

**Stator**

The non-rotating part of a magnetic structure. In a motor the stator usually contains the mounting surface, bearings, and non-rotating windings or permanent magnets.

**Tachometer**

An electromagnetic feedback transducer which produces an analog voltage signal proportional to rotational velocity. Tachometers can be either brush or brushless.

**Torque**

The rotary equivalent to force. Equal to the product of the force perpendicular to the radius of motion and distance from the center of rotation to the point where the force is applied.

**Velocity**

The change in position as a function of time. Velocity has both a magnitude and direction.



**INDEX****- A -**

Abbreviations.....	2-2
Analog Input Signals.....	1-5
Assembly.....	2-3
Mounting.....	2-3
Mounting the External Regeneration Resistor(s).....	2-4

**- B -**

Brushless DC Motor .....	1-3
--------------------------	-----

**- C -**

Checking the AC Line Voltages.....	2-13
Checking the DC Bus Voltages.....	2-13
Checking the Motor Wiring .....	2-13
Connecting the AC Input Voltage.....	2-6
Connecting the External Regeneration Resistor(s).....	2-7
Connecting the Main DC Bus Voltage.....	2-6
Connecting the Motor .....	2-12
Connecting the SERVOSTAR SP Series Drive Analog Input / Output (Connector C2).....	2-8
Connecting the SERVOSTAR SP Series Drive Digital Input / Output (Connector C3).....	2-9
Connecting the SERVOSTAR SP2 Series Drive Digital Input / Output (Connector C1).....	2-11
Connecting the Unregulated DC Voltage to the SERVOSTAR SP Series Drive (Connector C5) .....	2-7
Conventions .....	2-2
Abbreviations.....	2-2
Model Numbering Scheme .....	2-2
Current Feedback Signals .....	1-4
Current Ratings and Duty Cycles.....	1-5

**- D -****- E -**

Electrical Connections .....	2-4
Connecting the AC Input Voltage.....	2-6
Connecting the External Regeneration Resistor(s).....	2-7
Connecting the Main DC Bus Voltage.....	2-6
Connecting the Motor .....	2-12
Connecting the SERVOSTAR SP Series Drive Analog Input / Output (Connector C2).....	2-8
Connecting the SERVOSTAR SP Series Drive Digital Input / Output (Connector C3).....	2-9
Connecting the SERVOSTAR SP2 Series Drive Digital Input / Output (Connector C1).....	2-11
Connecting the Unregulated DC Voltage to the SERVOSTAR SP Series Drive (Connector C5) ...	2-7
Grounding Scheme.....	2-6
Recommended Torque for Electrical Connections.....	2-5
Electrical Noise.....	4-2
Enclosures.....	2-3
Environmental Requirements.....	2-3

- F -

Features ..... 1-1  
 Field Serviceability ..... 5-1

- G -

Grounding Integrity ..... 4-3  
 Grounding Scheme ..... 2-6

- H -

- I -

Initial Start-up ..... 3-1  
 Installation Checklist ..... 2-13  
     Checking the AC Line Voltages ..... 2-13  
     Checking the DC Bus Voltages ..... 2-13  
     Checking the Motor Wiring ..... 2-13  
 Installation Requirements ..... 2-3  
     Enclosures ..... 2-3  
     Environmental Requirements ..... 2-3

- J -

- K -

- L -

- M -

Model Numbering Scheme ..... 2-2  
 Mounting ..... 2-3  
 Mounting the External Regeneration Resistor(s) ..... 2-4

- N -

- O -

- P -

Periodic Maintenance ..... 4-3  
     Grounding Integrity ..... 4-3  
     Ventilation ..... 4-3  
 Power Supply Amp Status LED's ..... 5-3  
 Power Supply Module ..... 1-2  
 Power Up/Down Sequencing ..... 1-3

## - P - (continued)

Preventative Maintenance .....	4-1
Electrical Noise.....	4-2
Radio Frequency Energy` .....	4-2
Surge Current.....	4-2
Transient Voltages .....	4-1
PWM Input Command Signals .....	1-4

## - Q -

## - R -

Radio Frequency Energy` .....	4-2
Recommended Torque for Electrical Connections.....	2-5

## - S -

Safety Information .....	2-1
Sequence of Operations .....	3-1
SERVOSTAR SP Drive Module.....	1-2
SERVOSTAR SP Series Drive or Power Supply Reset Procedures.....	5-3
SERVOSTAR SP Series Drive Status LED's .....	5-2
Signal Information .....	1-4
Analog Input Signals.....	1-5
Current Feedback Signals .....	1-4
PWM Input Command Signals .....	1-4
Six-step Commutation.....	1-5
Six-step Commutation.....	1-5
Surge Current.....	4-2
Symptoms and Corrections .....	5-2
Power Supply Amp Status LED's.....	5-3
SERVOSTAR SP Series Drive or Power Supply Reset Procedures.....	5-3
SERVOSTAR SP Series Drive Status LED's .....	5-2
The Motor Exhibits Very Low Torque or is Totally Inoperative.....	5-2
The Motor is Erratic or Exhibits an Improper Mode of Operation .....	5-2

## - T -

The Motor Exhibits Very Low Torque or is Totally Inoperative .....	5-2
The Motor is Erratic or Exhibits an Improper Mode of Operation .....	5-2
Theory of Operation.....	1-2
Brushless DC Motor .....	1-3
Power Supply Module.....	1-2
Power Up/Down Sequencing .....	1-3
SERVOSTAR SP Drive Module .....	1-2
Transient Voltages .....	4-1
Typical System Diagram.....	1-4

## - U -

Unpacking and Inspection.....2-2

- V -

Ventilation.....4-3

- W -

- X -

- Y -

- Z -

