



DBL/DBK

Synchronous Servomotors

Product Manual

Edition 12/2010

Translation of the original version



Keep all manuals as a product component during the life span of the motor.
Pass all manuals to future users / owners of the motor.

File dblbdk_e.***

KOLLMORGEN

Choose your Motor:

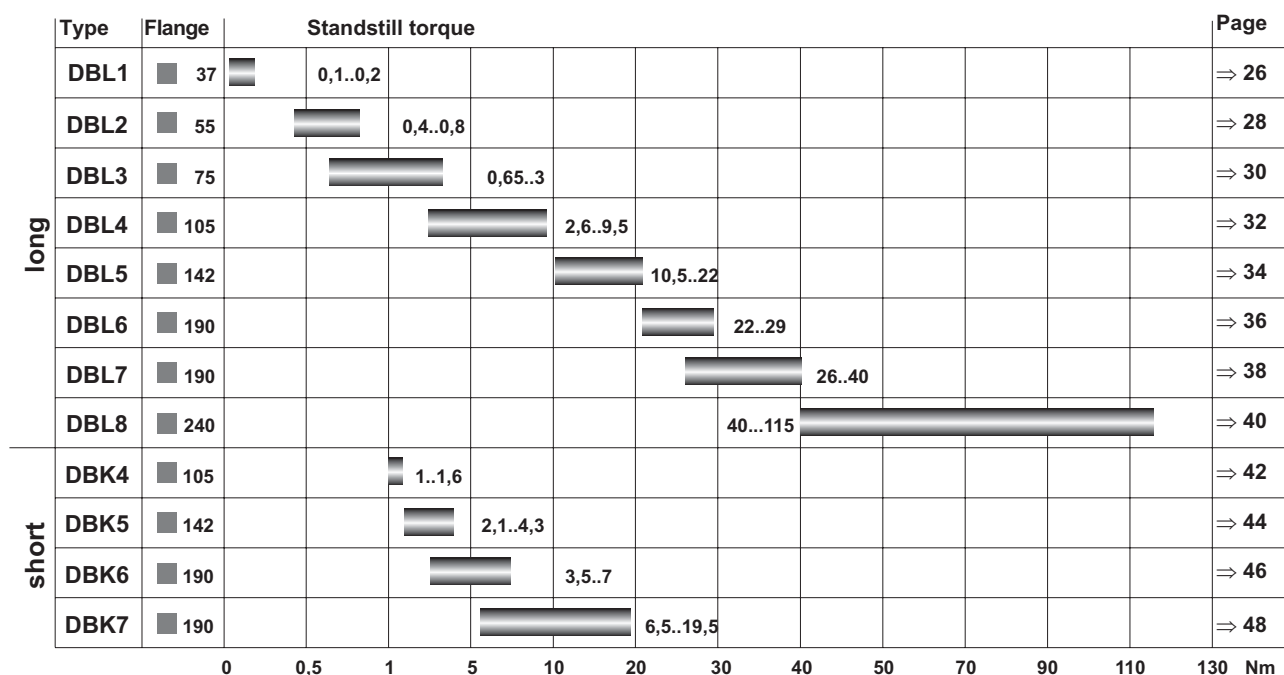

Already published editions

Edition	Comments
04 / 2001	First edition
05 / 2001	some minor corrections
07 / 2001	some minor corrections, model number description new, name plate new, dimension drawings optimized
02 / 2002	some minor corrections, encoder dimensions added
07 / 2002	new layout, resolver connection corrected
03 / 2003	new model numbers, dimension drawings corrected
01 / 2004	some minor corrections, Tolerance for technical data supplemented
05 / 2006	technical data updated, some minor corrections, order codes cables, performance curves removed
09 / 2006	New design, new structure, gearbox reference list new
09 / 2007	Branding, axial forces, symbols, CE-Declaration, material data for cables
10 / 2007	Nameplate, vibration class, target group, prohibited use
12 / 2010	New company name, brand logo, nameplate, CE certificate

Technical changes to improve the performance of the equipment may be made without prior notice!

Printed in the Federal Republic of Germany

All rights reserved. No part of this work may be reproduced in any form (by photocopying, microfilm or any other method) or stored, processed, copied or distributed by electronic means without the written permission of Kollmorgen Europe GmbH.

1	General	
1.1	About this manual	5
1.2	Target group	5
1.3	Symbols used	5
1.4	Abbreviations used	5
2	Safety	
2.1	Safety Notes	6
2.2	Use as directed	7
2.3	Prohibited use	7
3	Standards	
3.1	EC Declaration of Conformity	8
4	Handling	
4.1	Transport	9
4.2	Packaging	9
4.2.1	Storage	9
4.3	Maintenance / Cleaning	9
4.4	Disposal	9
5	Package	
5.1	Delivery package	10
5.2	Nameplate	10
5.3	Model number description	11
6	Technical Description	
6.1	Design of the motors	12
6.2	General technical data	12
6.3	Standard features	13
6.3.1	Style	13
6.3.2	Shaft end, A-side	13
6.3.3	Flange	13
6.3.4	Protection class	13
6.3.5	Protective device	13
6.3.6	Insulation material class	13
6.3.7	Vibration class	14
6.3.8	Connection method	14
6.3.9	Feedback unit	14
6.3.10	Holding brake	14
6.3.11	Pole numbers	14
6.4	Options	15
6.5	Selection criteria	15
7	Mechanical Installation	
7.1	Important Notes	16
8	Electrical Installation	
8.1	Safety notes	17
8.2	Guide to electrical installation	18
8.3	Connection of the motors	18
8.4	Wiring diagrams	19
8.4.1	Wiring diagram for resolver motors	19
8.4.2	Wiring diagram for encoder motors	20
8.5	Pin assignment	21
8.5.1	DBL1	21
8.5.2	DBL2...6, DBK4...7	21
8.5.3	DBL7...8	22
9	Setup	
9.1	Important notes	23
9.2	Guide to setup	23
9.3	Trouble Shooting	24

10 Technical data

10.1	Definitions	25
10.2	DBL1	26
10.3	DBL2	28
10.4	DBL3	30
10.5	DBL4	32
10.6	DBL5	34
10.7	DBL6	36
10.8	DBL7	38
10.9	DBL8	40
10.10	DBK4	42
10.11	DBK5	44
10.12	DBK6	46
10.13	DBK7	48

11 Appendix

11.1	Assignment of RediMount gearhead mounts	50
11.2	Assignment of Micron Gearheads to RediMount mounts	50
11.3	Index	51

1 General

1.1 About this manual

This manual describes the DBL/DBK series of synchronous servomotors (standard version).

The motors are operated in drive systems together with Kollmorgen servo amplifiers. Please observe the entire system documentation, consisting of:

- Product manual for the servo amplifier
- Installation and setup instructions for any expansion card which is connected
- Online help of the amplifier's setup software
- Accessories manual
- Technical description of the DBL/DBK series of motors (this manual)

More background information can be found in our "Product WIKI", available at www.wiki-kollmorgen.eu.

1.2 Target group

This manual addresses personnel with the following qualifications:

- Transport : only by personnel with knowledge of handling electrostatically sensitive components.
- Mech. Installation : only by mechanically qualified personnel.
- Electr. Installation : only by electrically qualified personnel.
- Setup : only by qualified personnel with extensive knowledge of electrical engineering and drive technology

The qualified personnel must know and observe the following standards:
IEC 60364 or IEC 60664
national accident prevention regulations



The operator must ensure that the safety instructions in this manual are followed. The operator must ensure that all personnel responsible for working with the motor have read and understood the product manual.

1.3 Symbols used

	Danger to personnel from electricity and its effects		General warning general instruction mechanical hazard
⇒	see chapter/page (cross reference)	●	special emphasis

1.4 Abbreviations used

see chapter 10.1 "Definition of Terms".

2 Safety

2.1 Safety Notes



- Only properly qualified personnel are permitted to perform such tasks as transport, assembly, setup and maintenance. Properly qualified personnel are persons who are familiar with the transport, assembly, installation, setup and operation of motors, and who have the appropriate qualifications for their jobs. The qualified personnel must know and observe the following standards and regulations:
 - IEC 60364 or IEC 60664
 - national regulations for safety and accident prevention
- Read the available documentation before assembly and setup. Incorrect handling of the motors can result in injury and damage to persons and machinery. Keep strictly to the technical data and the information on the connection requirements (nameplate and documentation).



- The manufacturer of the machine must generate a hazard analysis for the machine, and take appropriate measures to ensure that unforeseen movements cannot cause injury or damage to any person or property.
- It is vital that you ensure that the motor housing is safely earthed to the PE(protective earth) busbar in the switch cabinet. Electrical safety is impossible without a low-resistance earth connection.
- Do not unplug any connectors during operation. This creates the danger of death, severe injury, or extensive material damage.
- Power connections may be live even when the motor is not rotating. Never disconnect the power connections of the motor while the equipment is energised. This can cause flashovers with resulting injuries to persons and damage to the contacts.
- After disconnecting the servo amplifier from the supply voltage, wait at least five minutes before touching any components which are normally live (e.g. contacts, screw connections) or opening any connections.
The capacitors in the servo amplifier can still carry a dangerous voltage up to five minutes after switching off the supply voltages. To be quite safe, measure the DC-link voltage and wait until the voltage has fallen below 40V.
- The surfaces of the motors can be very hot in operation, according to their protection category. The surface temperature can reach 100°C. Measure the temperature, and wait until the motor has cooled down below 40°C before touching it.
- Remove any fitted key (if present) from the shaft before letting the motor run independently, to avoid the dangerous results of the key being thrown out by centrifugal forces.

2.2 Use as directed

- The DBL/DBK series of synchronous servomotors is designed especially for drives for industrial robots, machine tools, textile and packing machinery and similar with high requirements for dynamics.
- The user is **only** permitted to operate the motors under the ambient conditions which are defined in this documentation.
- The DBL/DBK series of motors is **exclusively** intended to be driven by digital servo amplifiers under speed and / or torque control.
- The motors are installed as components in electrical apparatus or machines and can only be commissioned and put into operation as integral components of such apparatus or machines.
- The thermal contact which is integrated in the motor windings must be observed and evaluated.
- The conformity of the servo-system to the standards mentioned in the manufacturers declaration on page 8 is only guaranteed when the components (servo amplifier, motor, leads etc.) that are used have been supplied by us.

2.3 Prohibited use

- The use of the motors in the following environments is prohibited:
 - potentially explosive areas
 - environments with corrosive and/or electrically conductive acids, alkaline solutions, oils, vapours, dusts
 - directly on supply networks
- Commissioning the motor is prohibited if the machine in which it was installed
 - does not meet the requirements of the EC Machinery Directive
 - does not comply with the EMC Directive
 - does not comply with the Low Voltage Directive
- Built-in holding brakes without further equipment must not be used to ensure personnel safety.

3 Standards

3.1 EC Declaration of Conformity

We, the company

Kollmorgen Europe GmbH
Pempelfurtstraße 1
D-40880 Ratingen

hereby in sole responsibility declare the conformity of the product series

Motor series DBL/DBK

(Types DBL1, DBL2, DBL3, DBL4, DBL5, DBL6, DBL7, DBL8, DBK4, DBK5, DBK6, DBK7)

with the following standards:

- EC Directive 2004/108/EC
Electromagnetic compatibility
Used standard EN61800-3:07/2005
- EC Directive 2006/95/EC
Electrical devices for use in special voltage limits
Used standard EN61800-5-1:04/2008

Year of EC-Declaration 2000

Issued by: Product Manager Motors Europe
 Jörg Peters
 Ratingen, 01.12.2010

Legally valid signature



This Declaration does not contain any assurance of properties in the meaning of product liability. The notes on safety and protection in the operating instructions must always be observed. The above-mentioned company has the following technical documentation for examination:

- Proper operating instructions
- Diagrams (for EU authority only)
- Test certificates (for EU authority only)
- Other technical documentation (for EU authority only)

4 Handling

4.1 Transport

- Climate category 2K3 to EN61800-2
- Transport temperature -25...+70°C, max. 20K/hr change
- Transport humidity rel. humidity 5% - 95% , no condensation
- Only by qualified personnel in the manufacturer's original recyclable packaging
- Avoid shocks, especially to the shaft end
- If the packaging is damaged, check the motor for visible damage. Inform the carrier and, if appropriate, the manufacturer.

4.2 Packaging

Motor type	Carton	Pallet or skeleton box	Max.stacking height	Motor type	Carton	Pallet or skeleton box	Max.stacking height
DBL1	X		10	DBL7	X	X	1
DBL2	X		10	DBL8		X	1
DBL3	X		6	DBK4	X		6
DBL4	X		6	DBK5	X		5
DBL5	X		5	DBK6	X	X	1
DBL6	X	X	1	DBK7	X	X	1

4.2.1 Storage

- Climate category 1K4 to EN61800-2
- Storage temperature - 25...+55°C, max. variation 20K/hr.
- Humidity rel. humidity 5% - 95%, no condensation
- Store only in the manufacturer's original recyclable packaging
- Max. stacking height see table under Packaging
- Storage time unlimited

4.3 Maintenance / Cleaning

- Maintenance and cleaning only by qualified personnel
- The ball bearings have a grease packing which is adequate for 20,000 hours of operation under normal conditions. The bearings should be replaced after 20,000 hours of operation under rated conditions (by manufacturer).
- Check the motor for bearing noise every 2500 operating hours, respectively each year. If any noises are heard, then the operation of the motor must stop, the bearings must be replaced (by manufacturer).
- Opening the motor invalidates the warranty.
- If the housing is dirty, clean housing with Isopropanol or similar, **do not immerse or spray**

4.4 Disposal

In accordance to the WEEE-2002/96/EG-Guidelines we take old devices and accessories back for professional disposal, if the transport costs are taken over by the sender. Send the devices to:
 Kollmorgen Europe GmbH
 Pempelfurtstraße 1
 D-40880 Ratingen

5 Package

5.1 Delivery package

- Motor from the DBL/DBK series
- Technical description on CDROM
- Motor package leaflet (short info)

5.2 Nameplate

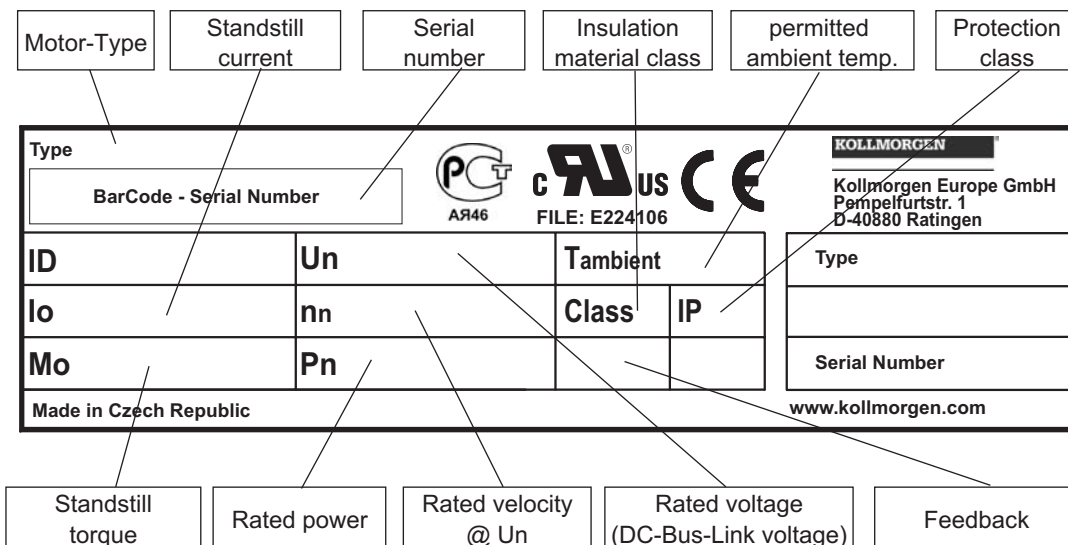

5.3

Model number description

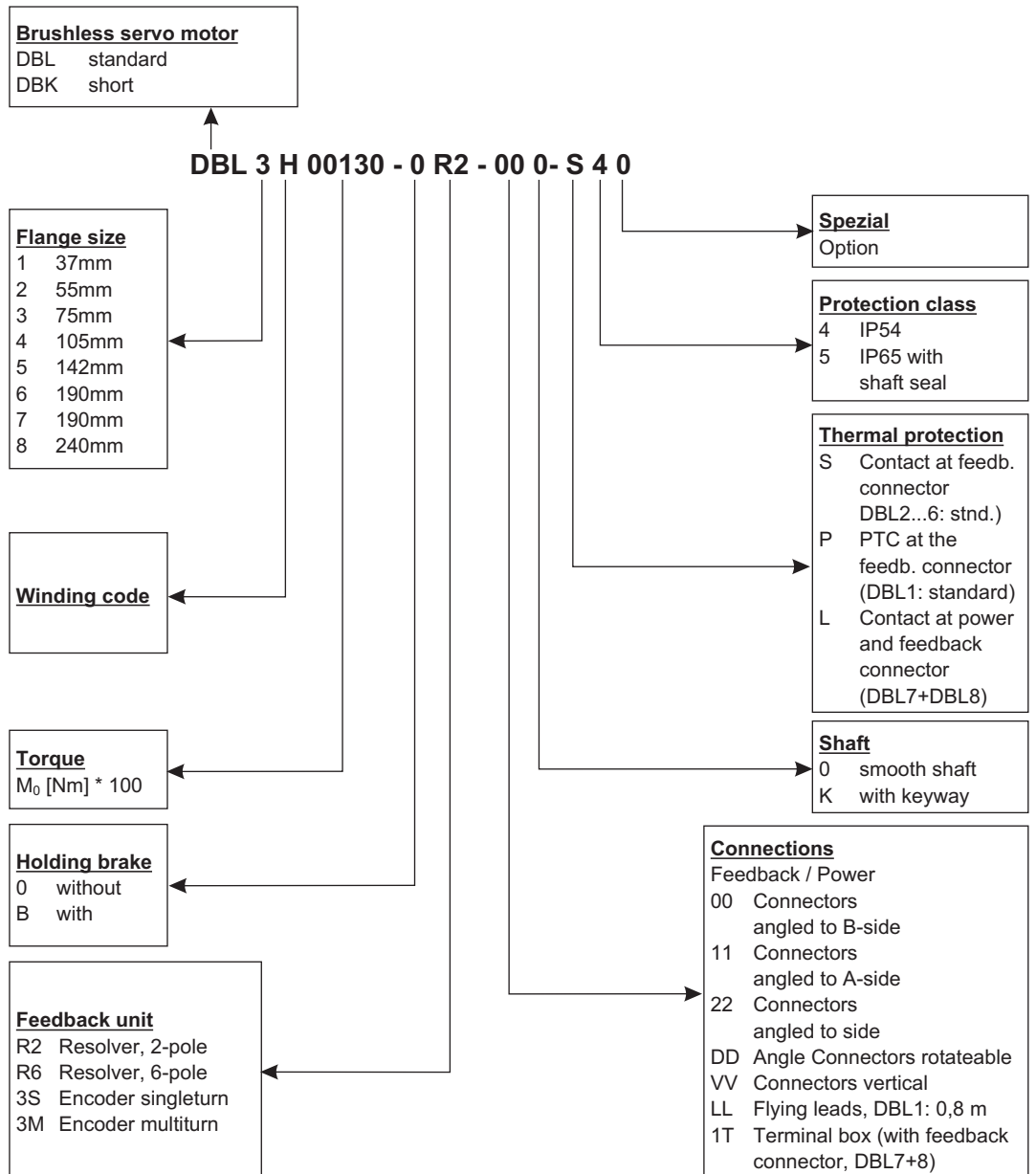

6 Technical Description

6.1 Design of the motors

Synchronous servomotors in the DBL/DBK series are brushless DC motors for demanding servo applications. When combined with our digital servo amplifiers they are especially suited for positioning tasks in industrial robots, machine tools, transfer lines etc. With high requirements for dynamics and stability.

The servomotors have permanent magnets in the rotor. The rare earth neodymium -iron-boron magnetic material is an important factor in making it possible to drive these motors in a highly dynamic fashion. A three-phase winding which is driven by the servo amplifier is integrated into the stator. The motor does not have any brushes since commutation is performed electronically by the servo amplifier.

The temperature of the winding is monitored by temperature sensors in the stator windings and is signalled via an electrically isolated contact (normally closed, DBL1: PTC/3kΩ).

A **resolver** is built into the motors as standard feedback element. The servo amplifiers evaluate the resolver position and supply sinusoidal currents to the motors.

The motors can be delivered with or without a built-in holding brake. Retrofitting of the brake is not possible.

The motors are enamelled in matt black (RAL 9005). This finish is not resistant against solvents (e.g. trichlorethylene, nitro-thinners, or similar).

6.2 General technical data

Climate category	3K3 to EN61800-2
Ambient temperature (at rated values)	5...+40°C for site altitude up to 1000m amsl It is vital to consult our applications department for ambient temperatures above 40°C and encapsulated mounting of the motors.
Permissible humidity (at rated values)	95% rel. humidity, no condensation
Power derating (currents and torques)	1% / K in range 40°C...50°C up to 1000m amsl for site altitude above 1000m amsl and 40°C 6% up to 2000m amsl 17% up to 3000m amsl 30% up to 4000m amsl 55% up to 5000m amsl No derating for site altitudes above 1000m amsl with temperature reduction of 10K / 1000m
Determination of nominal dates	Adapter flange with constantly 65°C
Ball-bearing life	≥ 20.000 operating hours
Technical data	⇒ p. 25
Storage data	⇒ p. 9

6.3 Standard features

6.3.1 Style

The basic style for the DBL/DBK synchronous motors is style IM B5 according to DIN EN 60034-7. The permitted mounting positions may be read from the technical data of the motor series.

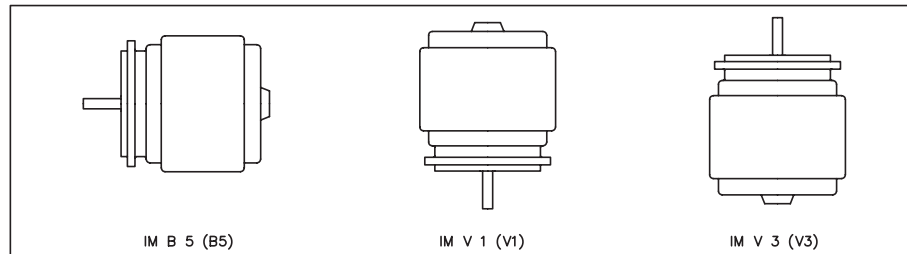

6.3.2 Shaft end, A-side

Power transmission is made through the cylindrical shaft end A (fit k6) to EN50347 , with a locking thread (except DBL1/DBL2) but **without a fitted-keyway**. Bearing life is calculated with 20.000 operating hours.

Radial force

If the motors drive via pinions or toothed belts, then high radial forces will occur. The permissible values at the end of the shaft may be read from the diagrams in chapter 10. The maximum values at rated speed you will find at the technical data. Power take-off from the middle of the free end of the shaft allows a 10% increase in F_R .

Axial force

When assembling pinions or wheels to the axis and use of e.g. angular gearheads axial forces arise. The maximum values you will find at the technical data.

Coupling

Double-coned collets have proved to be ideal zero-backlash coupling devices, combined, if required, with metal bellows couplings.

6.3.3 Flange

Flange dimensions to IEC standard, fit j6, accuracy according to DIN 42955. Tolerance class: **R**

6.3.4 Protection class

Standard version	IP65
Standard shaft bushing	IP54
Shaft bushing with shaft-sealing ring	IP65

6.3.5 Protective device

The standard version of each motor is fitted with a thermostat (electrically isolated, normally closed, DBL1: PTC/3k Ω). You will find the switching point at the technical data. The thermostat does **not** provide any protection against short, heavy overloading. Provided that our preassembled resolver cable is used, the thermostat contact is integrated into the monitoring system of the digital servo amplifier. **The flange temperature must not exceed 65°C in rated operation.**

6.3.6 Insulation material class

The motors come up to insulation material class F according to IEC 60085 (UL 1446 class F).

6.3.7 Vibration class

The motors are made to vibration class A according to DIN EN 60034-14. For a speed range of 600-3600 rpm and a shaft centre between 56-132mm, this means that the actual value of the permitted vibration severity is 1.6mm/s.

Velocity [rpm]	max. rel. Vibration Displacement[μm]	max. Run-out [μm]
≤ 1800	90	23
> 1800	65	16

6.3.8 Connection method

Motor series	Resolver	Power
DBL1	Cable	Cable
DBL2..DBL6, DBK	Connector	Connector
DBL7, DBL8	Connector	Terminal box

The mating connectors are not part of the delivery package. We can supply preassembled resolver and power leads. In Chapter 8.3 you will find notes on the cable materials.

6.3.9 Feedback unit

Standard	Resolver	two-pole hollow-shaft
Option	EnDat Encoder, Single-Turn	DBL2: ECN 1113, DBL3-8/DBK4-7: ECN1313
Option	EnDat Encoder, Multi-Turn	DBL2: EQN 1125, DBL3-8/DBK4-7: EQN1325

The motor length changes when an encoder is mounted. Retrofitting is not possible.

6.3.10 Holding brake

The motors are optionally available with a holding brake. A permanent magnet brake (24V DC) is integrated into the motors. When this brake is de-energized it blocks the rotor.



Personal safety in case of hanging loads (vertical axes) can be ensured only by using an additional, external, mechanical brake.

If the brake is released then the rotor can be moved without a remanent torque.

The holding brakes are designed as standstill brakes and are not suited for repeated operational braking. In the case of frequent, operational braking, premature wear and failure of the holding brake is to be expected.

The motor length increases when a holding brake is mounted.

The holding brake can be controlled directly by Kollmorgen servo amplifiers (no personal safety!), the winding is suppressed in the servo amplifier — additional circuitry is not required.

If the holding brake is not controlled directly by the servo amplifier, an additional wiring (e.g. varistor) is required. Consult our applications department beforehand.

6.3.11 Pole numbers

The motors have 6 poles.

6.4 Options

— Holding brake

Built-in holding brake (\Rightarrow p.14).
Motor length increases by the holding brake.

— Radial shaft-sealing rings

A radial shaft-sealing ring can be supplied at extra charge to seal against oil mist and oil spray. This increases the protection rating of the shaft bushing to IP65. The sealing ring is not suitable for dry running. When a holding brake is built in, the motor length increases by a sealing ring for approximately 10mm.

— Vertical mounting sockets

If fitted with angular sockets for feedback and power connectors, the motors are also available with vertical sockets.

— Keyway

The motors are available with keyway and key inserted
The shaft is balanced with a short (half) key.

— EnDat

A high resolution EnDat-encoder is mounted instead of the resolver (\Rightarrow p.14).
The motor length increases by the encoder.

— 2nd Thermostat

An additional thermostat can be applied to the motor winding. The connection takes place via the power connector resp. the terminal box.

All options can **not** be retrofitted.

6.5 Selection criteria

The three-phase servomotors are designed to operate with Kollmorgen servo amplifiers. Together, both units form a closed speed or torque control loop.

The most important selection criteria are:

—	Standstill torque	M_0	[Nm]
—	Rated speed	n_n	[min ⁻¹]
—	Moment of inertia of motor and load	J	[kgcm ²]
—	Effective torque (calculated)	M_{rms}	[Nm]

When calculating the motors and servo amplifiers which are required, take account of the static load **and** the dynamic load (acceleration/braking). Collected formulae and examples of the calculations are available from our applications department.

7 Mechanical Installation

7.1 Important Notes



Only qualified staff with knowledge of mechanical engineering are permitted to assemble the motor.

- Protect the motor from unacceptable stresses. Take care, especially during transport and handling, that components are not bent and that insulation clearances are not altered.
- The site must be free of conductive and aggressive material. For V3-mounting (shaft end upwards), make sure that no liquids can enter the bearings. If an encapsulated assembly is required, please consult our applications department beforehand.
- Ensure an unhindered ventilation of the motors and observe the permissible ambient and flange temperatures. For ambient temperatures above 40°C please consult our applications department beforehand. Ensure that there is adequate heat transfer in the surroundings and the motor flange, so that the maximum permissible flange temperature of 65°C is not exceeded in S1 operation.
- Servomotors are precision equipment. The flange and shaft are especially vulnerable during storage and assembly — so avoid brute force. Precision requires delicacy. It is important to use the locking thread which is provided to tighten up couplings, gear wheels or pulley wheels and warm up the drive components, where possible. Blows or the use of force will lead to damage to the bearings and the shaft.

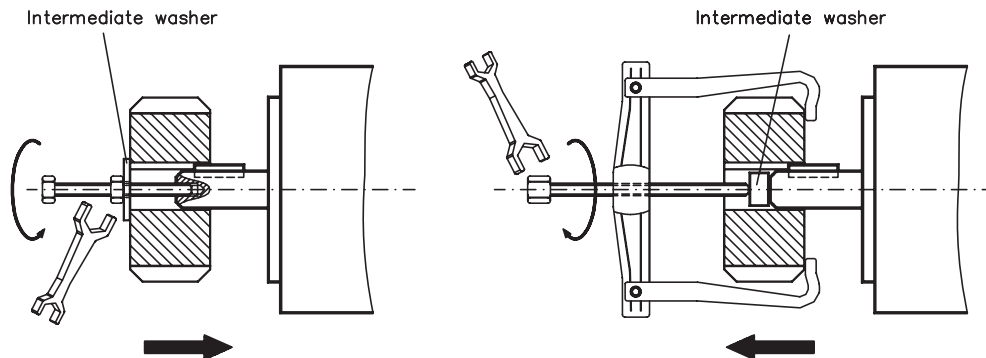

- Wherever possible, use only backlash-free, frictionally-locking collets or couplings. Ensure correct alignment of the couplings. A displacement will cause unacceptable vibration and the destruction of the bearings and the coupling.
- For toothed belts, it is vital to observe the permissible radial forces. An excessive radial load on the shaft will significantly shorten the life of the motor.
- Avoid axial loads on the motor shaft, as far as possible. Axial loading significantly shortens the life of the motor.
- In all cases, do not create a mechanically constrained motor shaft mounting by using a rigid coupling with additional external bearings (e.g. in a gearbox).
- Take note of the no. of motor poles (6-pole) and the no. of resolver poles (2-pole), and ensure that the correct setting is made in the servo amplifier which is used. An incorrect setting can lead to the destruction of the motor, especially with small motors.
- Check the compliance to the permitted radial and axial forces F_R and F_A . When you use a toothed belt drive, the **minimal** permitted diameter of the pinion e.g. follows from the equation: $d_{min} \geq \frac{M_0}{F_R} \times 2$.

8 Electrical Installation

8.1 Safety notes



Only staff qualified and trained in electrical engineering are allowed to wire up the motor.

Always make sure that the motors are de-energized during assembly and wiring, i.e. No voltage may be switched on for any piece of equipment which is to be connected.

Ensure that the switch cabinet remains turned off (barrier, warning signs etc.). The individual voltages will only be turned on again during setup

Never undo the electrical connections to the motor while it is energised. A dangerous voltage, resulting from residual charge, can be still present on the capacitors up to 5 minutes after switch-off of the mains supply.

Measure the DC-link voltage and wait until it has fallen below 40V.

Even when the motor is not rotating, control and power leads may be live.



The ground symbol |||| , which you will find in the wiring diagrams, indicates that you must provide an electrical connection, with as large a surface area as possible, between the unit indicated and the mounting plate in the switch cabinet. This connection is to suppress HF interference and must not be confused with the PE (protective earth) symbol (protective measure to EN 60204).

To wire up the motor, use the wiring diagrams in the Installation and Setup Instructions of the servo amplifier which is used.

8.2 Guide to electrical installation

- Check that the servo amplifier and motor match each other. Compare the rated voltage and rated current of the unit. Carry out the wiring according to the wiring diagram in the product manual of the servo amplifier. The connections to the motor are shown on pages 19f. Notes on the connection methods can be found on page 18.
- Ensure that there is proper earthing of the servo amplifier and the motor. Use correct earthing and EMC-shielding according to the product manual of the servo amplifier which is used. Earth the mounting plate and motor casing. For connection methods see chapter 8.3.
- Route the power and control cables as separately as possible from one another (separation > 20 cm). This will improve the immunity of the system to electromagnetic interference. If a motor power cable is used which includes integral brake control leads, then these brake control leads must be shielded. The shielding must be connected at both ends (see product manual for the servo amplifier).
- Wiring:
 - Route power cables as separately as possible from control cables
 - Connect up the resolver or encoder.
 - Connect the motor cables, install motor chokes close to the servo amplifier
 - Connect shields to shielding terminals or EMC with connectors at both ends
 - Connect the holding brake, if used
 - Connect shielding at both ends.
- Install all cables carrying a heavy current with an adequate cross-section, as per EN 60204. The recommended cross-section can be found in the Technical data.



In case of long motor cables (>25m) and dependent on the type of the used servo amplifier a motor choke (3YL) must be switched into the motor cable (see product manual of the servo amplifier and accessory manual).

- Connect up all shielding via a wide surface-area contact (low impedance) and metallized connector housings or EMC-cable glands.

8.3 Connection of the motors



- Carry out the wiring in accordance with the valid standards and regulations.
- Only use our preassembled shielded leads for the resolver and power connections.
- Connect up the shielding according to the wiring diagrams in the product manual of the used servo amplifier.
- Incorrectly installed shielding inevitably leads to EMC interference.
- The maximum cable length is defined in the product manual of the used servo amplifier.

Requirements to cable material:

Capacity

Motor cable	less than 150 pF/m
Resolver cable	less than 120 pF/m

For a detailed description of preassembled cables, please refer to the accessories manual.

8.4 Wiring diagrams

8.4.1 Wiring diagram for resolver motors

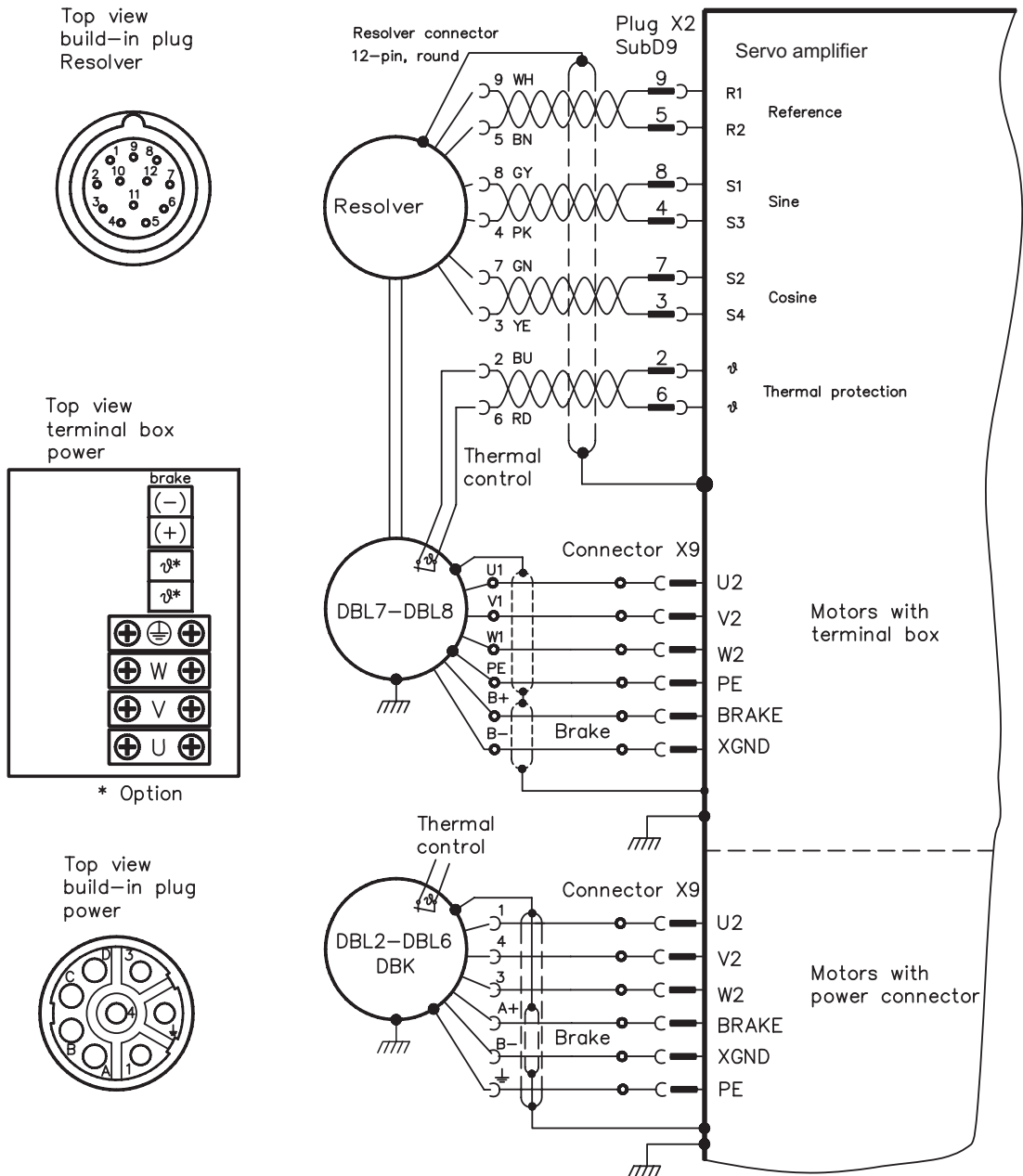

connector round, 12-poles

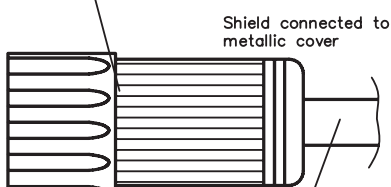

4 x 2 x 0,25 shielded, twisted pairs on request max. 100m

Sub-D connector 9-poles

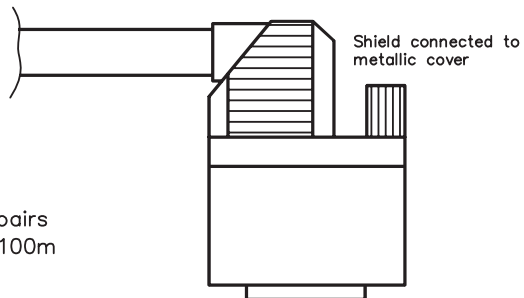

colour coding acc. to IEC 757

8.4.2 Wiring diagram for encoder motors

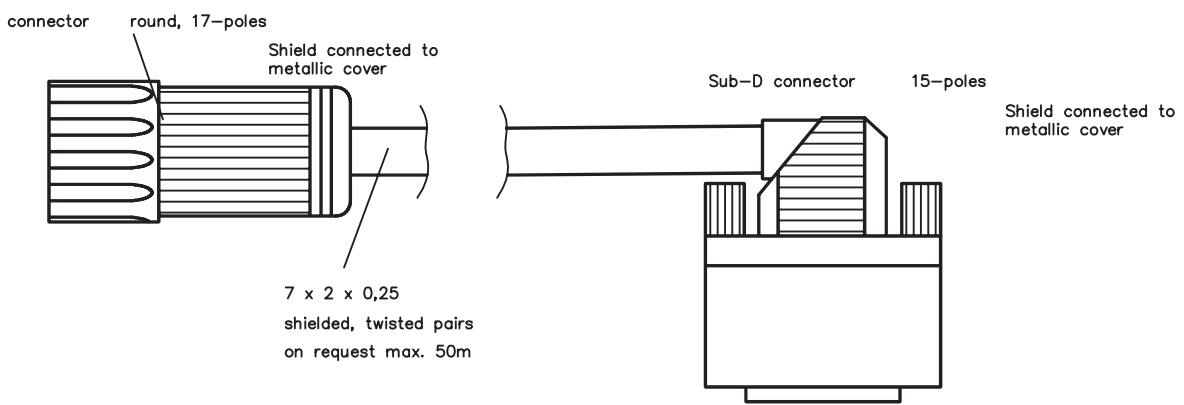
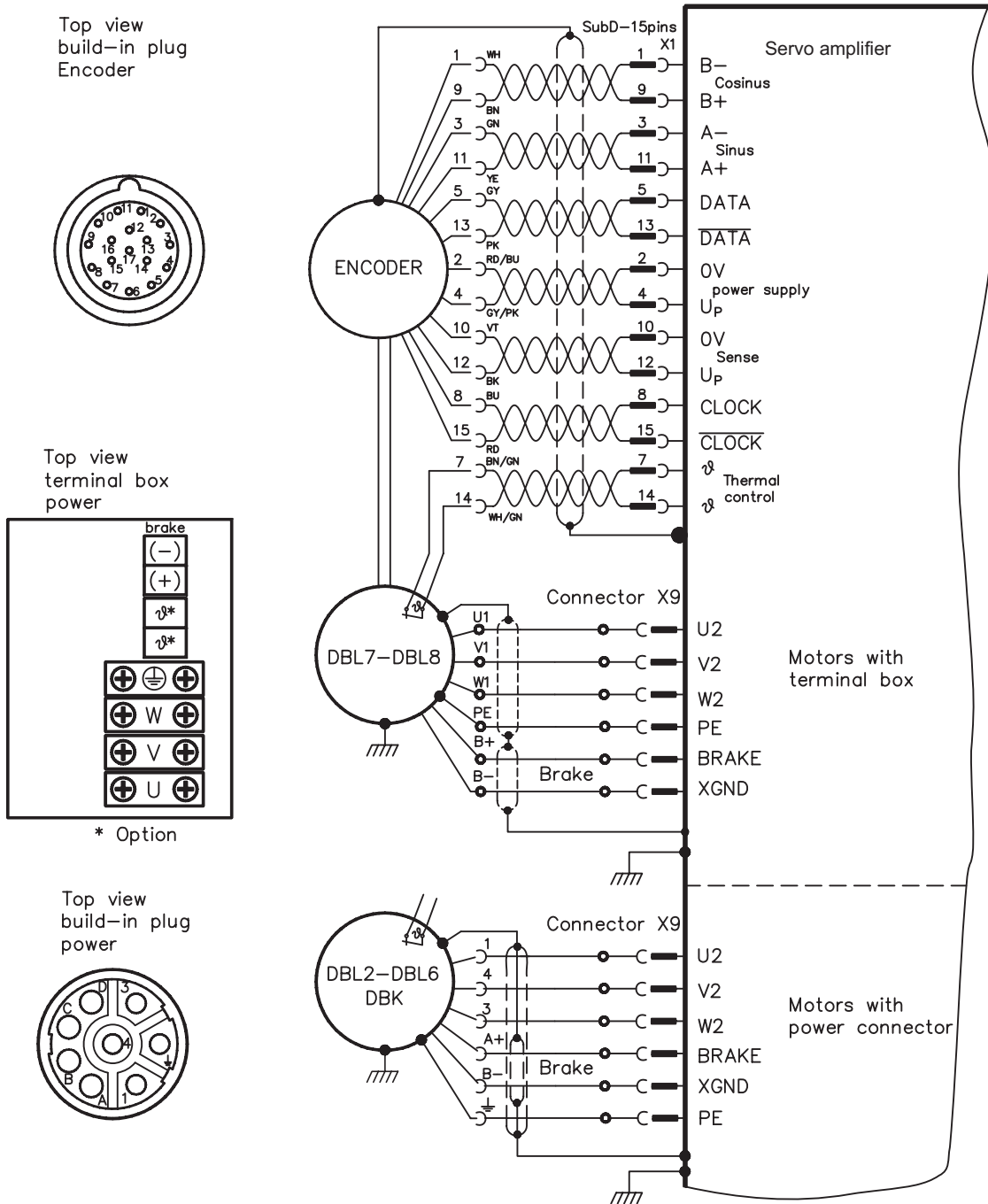

colour coding acc. to IEC 757

8.5 Pin assignment

8.5.1 DBL1

The motors of the DBL1 series are fitted with loose cables (length approx. 80cm). The cables are stripped, the power cores are additionally fitted with ferrules. The shielding braids are twisted to a cord each. The resolver leads are colour-coded, the power leads (except PE) are numbered.

Power Cable		Resolver Cable		
Lead	Connection	Lead	Connection	Pin-No. Resolver connector (servo amplifier)
1	U2	WH	- Reference	9
2	V2	BN	+ Reference	5
3	W2	GN	- Cosine	7
GNYE	PE	YE	+ Cosine	3
		GY	+ Sine	8
		PK	- Sine	4
		BU	Thermostat	2
		RD	Thermostat	6

8.5.2 DBL2...6, DBK4...7

View to the built-in connector.

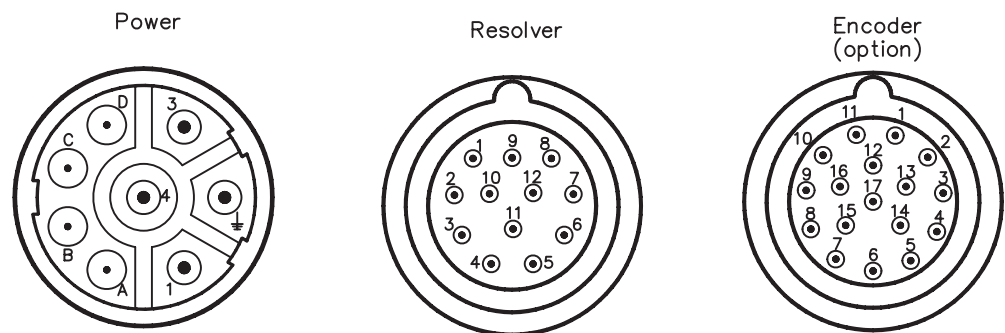

Power connector		Resolver connector		Encoder connector (Option)	
Pin	Connection	Pin	Connection	Pin	Connection
1	U2	1	n.c.	1	B- (Cosine)
⏚	PE	2	Thermostat	2	0 V (power supply)
3	W2	3	+ Cosine	3	A- (Sine)
4	V2	4	- Sine	4	U _P (power supply)
		5	+ Reference	5	DATA
A	Brake +	6	Thermostat	6	n.c.
B	Brake -	7	- Cosine	7	Thermostat
C	2nd Thermostat (Option)	8	+ Sine	8	CLOCK
D	2nd Thermostat (Option)	9	- Reference	9	B+ (Cosine)
		10	n.c.	10	0 V (Sense)
		11	n.c.	11	A+ (Sine)
		12	n.c.	12	U _P (Sense)
				13	DATA
				14	Thermostat
				15	CLOCK
				16	n.c.
				17	n.c.

8.5.3 DBL7...8

View to the built-in connector.

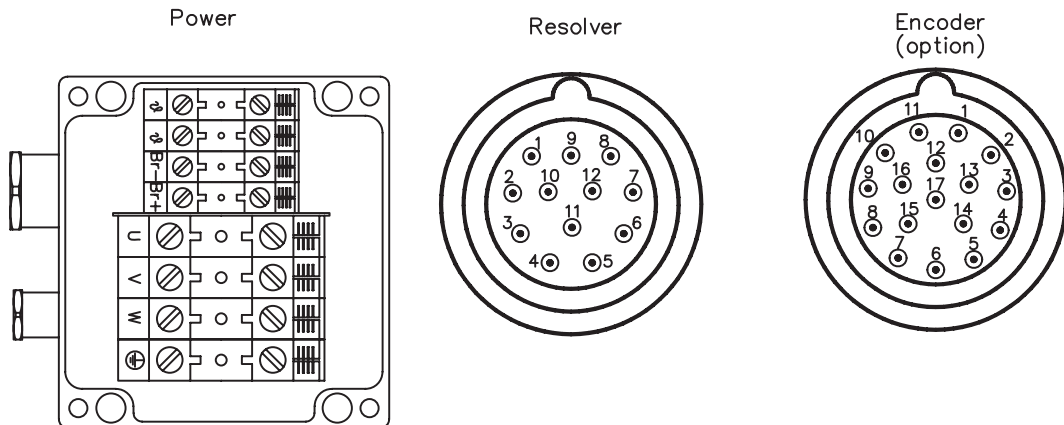

Terminal box		Resolver connector		Encoder connector (Option)	
Kl.	Connection	Pin	Connection	Pin	Connection
U	U2	1	n.c.	1	B- (Cosine)
⏚	PE	2	Thermostat	2	0 V (power supply)
V	V2	3	+ Cosine	3	A- (Sine)
W	W2	4	- Sine	4	U _P (power supply)
		5	+ Reference	5	DATA
(+)	Brake + (Option)	6	Thermostat	6	n.c.
(-)	Brake - (Option)	7	- Cosine	7	Thermostat
9	2nd Thermostat (Option)	8	+ Sine	8	CLOCK
9	2nd Thermostat (Option)	9	- Reference	9	B+ (Cosine)
		10	n.c.	10	0 V (Sense)
		11	n.c.	11	A+ (Sine)
		12	n.c.	12	U _P (Sense)
				13	DATA
				14	Thermostat
				15	CLOCK
				16	n.c.
				17	n.c.

9 Setup

9.1 Important notes



Only specialist personnel with extensive knowledge in the areas of electrical engineering / drive technology are allowed to commission the drive unit of servo amplifier and motor.

Check that all live connection points (terminal boxes) are safe against accidental contact. Deadly voltages can occur, up to 900V.

Never undo the electrical connections to the motor when it is live. The residual charge in the capacitors of the servo amplifier can produce dangerous voltages up to 5 minutes after the mains supply has been switched off.

The surface temperature of the motor can reach 100°C in operation. Check (measure) the temperature of the motor. Wait until the motor has cooled down below 40°C before touching it.

Make sure that, even if the drive starts to move unintentionally, no danger can result for personnel or machinery.

9.2 Guide to setup

The procedure for setup is described as an example. A different method may be appropriate or necessary, depending on the application of the equipment.

- Check the assembly and orientation of the motor.
- Check the drive components (clutch, gear unit, belt pulley) for the correct seating and setting (observe the permissible radial and axial forces).
- Check the wiring and connections to the motor and the servo amplifier. Check that the earthing is correct.
- Test the function of the holding brake, if used. (apply 24V, the brake must be released).
- Check whether the rotor of the motor revolves freely (release the brake, if necessary). Listen out for grinding noises.
- Check that all the required measures against accidental contact with live and moving parts have been carried out.
- Carry out any further tests which are specifically required for your system.
- Now commission the drive according to the setup instructions for the servo amplifier.
- In multi-axis systems, individually commission each drive unit (servo amplifier and motor).

9.3 Trouble Shooting

The following table is to be seen as a "First Aid" box. There can be a large number of different reasons for a fault, depending on the particular conditions in your system. The fault causes described below are mostly those which directly influence the motor. Peculiarities which show up in the control loop behaviour can usually be traced back to an error in the parameterization of the servo amplifier. The documentation for the servo amplifier and the setup software provides information on these matters.

For multi-axis systems there may be further hidden reasons for faults.

Our applications department can give you further help with your problems.

Fault	Possible cause	Measures to remove the cause of the fault
Motor doesn't rotate	<ul style="list-style-type: none"> — Servo-amplifier not enabled — Break in setpoint lead — Motor phases in wrong sequence — Brake not released — Drive is mechanically blocked 	<ul style="list-style-type: none"> — Supply ENABLE signal — Check setpoint lead — Correct the phase sequence — Check brake controls — Check mechanism
Motor runs away	<ul style="list-style-type: none"> — Motor phases in wrong sequence 	<ul style="list-style-type: none"> — Correct the phase sequence
Motor oscillates	<ul style="list-style-type: none"> — Break in the shielding of the resolver cable — amplifier gain too high 	<ul style="list-style-type: none"> — Replace resolver cable — use motor default values
Error message: brake	<ul style="list-style-type: none"> — Short-circuit in the supply voltage lead to the motor holding brake — Faulty motor holding brake 	<ul style="list-style-type: none"> — Remove the short-circuit — Replace motor
Error message: output stage fault	<ul style="list-style-type: none"> — Motor cable has short-circuit or earth short — Motor has short-circuit or earth short 	<ul style="list-style-type: none"> — Replace cable — Replace motor
Error message: resolver	<ul style="list-style-type: none"> — Resolver connector is not properly plugged in — Break in resolver cable, cable crushed or similar 	<ul style="list-style-type: none"> — Check connector — Check cables
Error message: motor temperature	<ul style="list-style-type: none"> — Motor thermostat has switched — Loose resolver connector or break in resolver cable 	<ul style="list-style-type: none"> — Wait until the motor has cooled down. Then investigate why the motor becomes so hot. — Check connector, replace resolver cable if necessary
Brake does not grip	<ul style="list-style-type: none"> — Required holding torque too high — Brake faulty — Motor shaft axially overloaded 	<ul style="list-style-type: none"> — Check the dimensioning — Replace motor — Check the axial load, reduce it. Replace motor, since the bearings have been damaged

10 Technical data

10.1 Definitions

Standstill torque M_0 [Nm]

The standstill torque can be maintained indefinitely at a speed $n=0 \text{ min}^{-1}$ and rated ambient conditions.

Rated torque M_n [Nm]

The rated torque is produced when the motor is drawing the rated current at the rated speed. The rated torque can be produced indefinitely at the rated speed in continuous operation (S1).

Standstill current I_{0rms} [A]

The standstill current is the effective sinusoidal current which the motor draws during standstill to produce the standstill torque.

Rated current I_{nrms} [A]

The rated current is the effective sinusoidal current which the motor draws at the rated speed in order to produce the rated torque.

Peak current (pulse current) I_{0max} [A]

The peak current (effective sinusoidal value) is approximately equivalent to 4-times the rated current. The actual value is determined by the peak current of the servo amplifier which is used.

Torque constant K_{Trms} [Nm/A]

The torque constant defines how much torque in Nm is produced by the motor with 1A r.m.s. current. The relationship is $M=I \times K_T$ (up to $I = 2 \times I_0$)

Voltage constant K_{Erms} [mV/min⁻¹]

The voltage constant defines the induced motor EMF, as an effective sinusoidal value between two terminals, per 1000 rpm

Rotor moment of inertia J [kgcm²]

The constant J is a measure of the acceleration capability of the motor. For instance, at I_0 the acceleration time t_b from 0 to 3000 rpm is given as:

$$t_b [\text{s}] = \frac{3000 \times 2\pi}{M_0 \times 60\text{s}} \times \frac{m^2}{10^4 \times \text{cm}^2} \times J \quad \text{with } M_0 \text{ in Nm and } J \text{ in kgcm}^2$$

Thermal time constant t_{th} [min]

The constant t_{th} defines the time for the cold motor, under a load of I_0 , to heat up to an overtemperature of 0.63×105 Kelvin. This temperature rise happens in a much shorter time when the motor is loaded with the rated current.

Release delay time t_{BRH} [ms] / Application delay time t_{BRL} [ms] of the brake

These constants define the response times of the holding brake when operated with the rated voltage from the servo amplifier.

U_N

Rated mains voltage

U_n

DC-Bus link voltage. $U_n = \sqrt{2} * U_N$

10.2

DBL1

The data can have a tolerance of +/- 10%.

Technical data

Data		Symbol [Unit]	DBL1 X00010	DBL1 X00020
Electrical data				
	Standstill torque	M_0 [Nm]	0,1	0,2
	Standstill current	I_{0rms} [A]	0,60	0,93
	Mains voltage	U_N [VAC]	230	
$U_N = 230V$	Rated speed	n_n [min ⁻¹]	6000	6000
	Rated torque	M_n [Nm]	0,09	0,18
	Rated current	I_n [A]	0,56	0,89
	Rated power	P_n [kW]	0,06	0,11
$U_N = 400V$	Rated speed	n_n [min ⁻¹]	—	—
	Rated torque	M_n [Nm]	—	—
	Rated current	I_n [A]	—	—
	Rated power	P_n [kW]	—	—
$U_N = 480V$	Rated speed	n_n [min ⁻¹]	—	—
	Rated torque	M_n [Nm]	—	—
	Rated current	I_n [A]	—	—
	Rated power	P_n [kW]	—	—
	Peak current	I_{0max} [A]	2,5	4,2
	Torque constant	K_{Trms} [Nm/A]	0,17	0,22
	Voltage constant	K_{Erms} [mVmin]	10,5	13
	Winding resistance Ph-Ph	R_{20} [Ω]	38,9	18,9
	Winding inductance Ph-Ph	L [mH]	6,5	4,5
Mechanical data				
	Rotor moment of inertia	J [kgcm ²]	0,06	0,08
	Static friction torque	M_R [Nm]	0,01	0,01
	Thermal time constant	t_{TH} [min]	18	20
	Weight standard	G [kg]	0,37	0,45
	Radial load permitted at shaft end @ 6000 min ⁻¹	F_R [N]	60	
	Axial load max. permitted	F_A [N]	60	
	Motor number		00647R	00670R

Brake data

Data	Symbol [Unit]	Value
Holding torque	M_{BR} [Nm]	0,35
Operating voltage	U_{BR} [VDC]	24 +15 / -0 %
electrical power	P_{BR} [W]	8
Moment of inertia	J_{BR} [kgcm ²]	0,0013
Release delay time	t_{BRH} [ms]	10-20
Application delay time	t_{BRL} [ms]	5-10
Weight of the brake	G_{BR} [kg]	0,1

Connections and leads

Data	DBL1 X00010	DBL1 X00020
Power connection	cable	
Motor cable, shielded	4 x 1	
Resolver connection	cable	
Resolver cable, shielded	4 x 2 x 0,25mm ²	

Dimensions (drawing in principle)

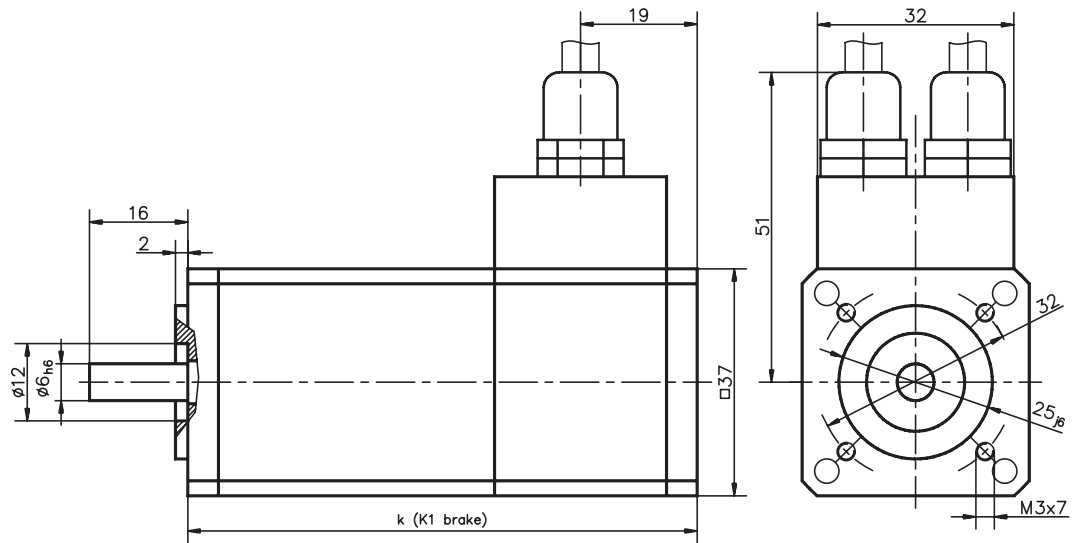

TYP	K	K1
DBL1X00010	83	113
DBL1X00020	99	123

Radial forces at the shaft end

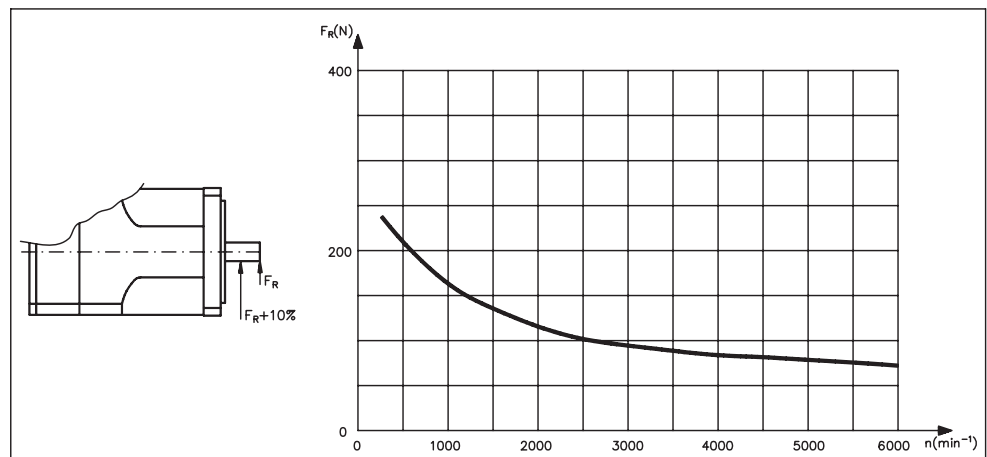

10.3

DBL2

The data can have a tolerance of +/- 10%.

Technical data

Data		Symbol [Unit]	DBL2 H00040	DBL2 H00060	DBL2 M00080	DBL2 H00080
Electrical data						
	Standstill torque	M_0 [Nm]	0,4	0,6	0,8	0,8
	Standstill current	I_{0rms} [A]	0,91	1,4	0,85	1,51
	Mains voltage	U_N [VAC]	230-400			
$U_N = 230V$	Rated speed	n_n [min ⁻¹]	4500	4500	—	4500
	Rated torque	M_n [Nm]	0,36	0,55	—	0,72
	Rated current	I_n [A]	0,90	1,42	—	1,45
	Rated power	P_n [kW]	0,17	0,26	—	0,34
$U_N = 400V$	Rated speed	n_n [min⁻¹]	6000	6000	4500	6000
	Rated torque	M_n [Nm]	0,34	0,52	0,72	0,69
	Rated current	I_n [A]	0,85	1,3	0,8	1,4
	Rated power	P_n [kW]	0,21	0,33	0,34	0,43
$U_N = 480V$	Rated speed	n_n [min ⁻¹]	—	—	—	—
	Rated torque	M_n [Nm]	—	—	—	—
	Rated current	I_n [A]	—	—	—	—
	Rated power	P_n [kW]	—	—	—	—
	Peak current	I_{0max} [A]	3,9	6	3,6	6,7
	Torque constant	K_{Trms} [Nm/A]	0,44	0,43	0,94	0,53
	Voltage constant	K_{Erms} [mVmin]	26,5	26	57	32
	Winding resistance Ph-Ph	R_{20} [Ω]	26	15,1	46,5	14,6
	Winding inductance Ph-Ph	L [mH]	21,5	13,5	46,2	14,4
Mechanical data						
	Rotor moment of inertia	J [kgcm ²]	0,08	0,11	0,13	
	Static friction torque	M_R [Nm]	0,02	0,02	0,02	
	Thermal time constant	t_{TH} [min]	15	20	22	
	Weight standard	G [kg]	1,06	1,21	1,36	
	Radial load permitted at shaft end @ 3000 min ⁻¹	F_R [N]	115			
	Axial load max. permitted	F_A [N]	81			
	Motor number		00728R	00771R	00348R	00772R

Brake data

Data	Symbol [Unit]	Value
Holding torque	M_{BR} [Nm]	1,2
Operating voltage	U_{BR} [VDC]	24 +15 / -0 %
electrical power	P_{BR} [W]	8
Moment of inertia	J_{BR} [kgcm ²]	0,07
Release delay time	t_{BRH} [ms]	15-20
Application delay time	t_{BRL} [ms]	5-10
Weight of the brake	G_{BR} [kg]	0,3

Connections and leads

Data	DBL2 H00040	DBL2 H00060	DBL2 M00080	DBL2 H00080
Power connection	4 + 4 poles, round, angular			
Motor cable, shielded	4 x 1			
Motor cable with control leads, shielded	4 x 1 + 2 x 0,75			
Resolver connection	12 poles, round, angular			
Resolver cable, shielded	4 x 2 x 0,25mm ²			
Encoder connection (Option)	17 poles, round, angular			
Encoder cable, shielded	7 x 2 x 0,25mm ²			

Dimensions (drawing in principle)

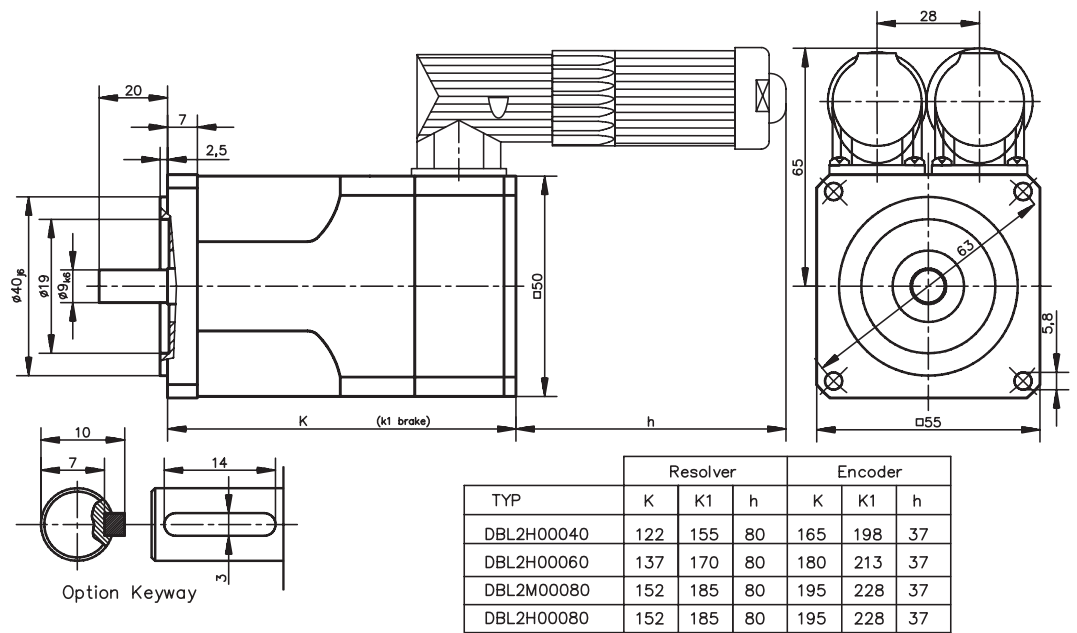

Radial forces at the shaft end

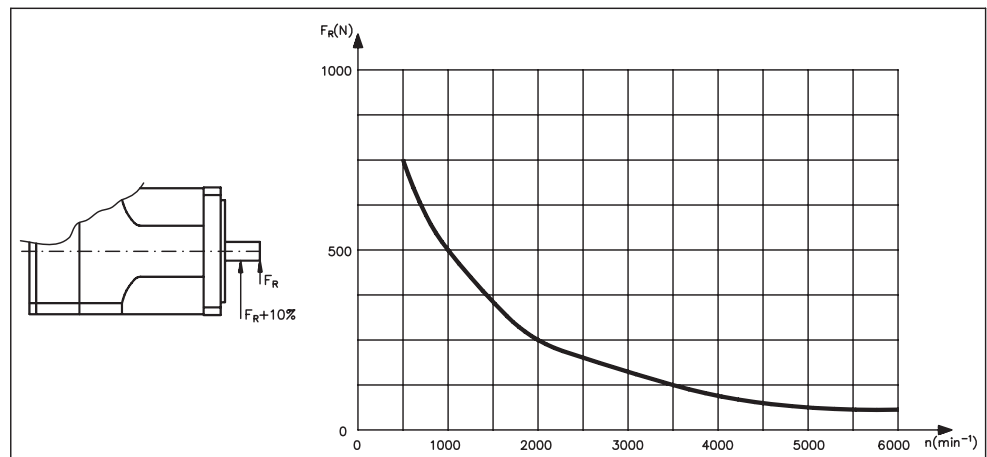

10.4

DBL3

The data can have a tolerance of +/- 10%.

Technical data

Data	Symbol [Unit]	DBL3 N00065	DBL3 H00065	DBL3 N00130	DBL3 H00130	DBL3 M00190	DBL3 H00250	DBL3 N00300
Electrical data								
Standstill torque	M_0 [Nm]	0,65	0,65	1,3	1,3	1,9	2,5	3,0
Standstill current	I_{0rms} [A]	0,65	1,06	1,01	1,67	1,42	3,0	2,1
Mains voltage	U_N [VAC]	230-480						
$U_N = 230V$	Rated speed	n_n [min ⁻¹]	—	3000	—	3000	—	3000
	Rated torque	M_n [Nm]	—	0,6	—	1,2	—	2,2
	Rated current	I_n [A]	—	1,05	—	1,6	—	2,7
	Rated power	P_n [kW]	—	0,19	—	0,38	—	0,69
$U_N = 400V$	Rated speed	n_n [min ⁻¹]	3000	6000	3000	6000	3000	6000
	Rated torque	M_n [Nm]	0,60	0,55	1,15	1	1,6	1,80
	Rated current	I_n [A]	0,64	0,97	0,95	1,4	1,26	2,30
	Rated power	P_n [kW]	0,19	0,30	0,38	0,69	0,50	1,13
$U_N = 480V$	Rated speed	n_n [min ⁻¹]	3600	—	3600	—	3600	—
	Rated torque	M_n [Nm]	0,58	—	1,15	—	1,54	—
	Rated current	I_n [A]	0,59	—	0,90	—	1,21	—
	Rated power	P_n [kW]	0,22	—	0,43	—	0,58	—
Peak current	I_{0max} [A]	2,8	4,6	4,3	7,52	6,1	13	9
Torque constant	K_{Trms} [Nm/A]	0,99	0,60	1,29	0,78	1,34	0,83	1,44
Voltage constant	K_{Erms} [mVmin]	60	37	78	47	81	50	87
Winding resistance Ph-Ph	R_{20} [Ω]	75	28,5	34,5	12,7	20,9	5,4	11,6
Winding inductance Ph-Ph	L [mH]	88	33,3	62	21,5	40,4	11,7	26,7
Mechanical data								
Rotor moment of inertia	J [kgcm ²]	0,39		0,65		0,92	1,2	1,5
Static friction torque	M_R [Nm]	0,02		0,02		0,03	0,05	0,05
Thermal time constant	t_{TH} [min]	25		30		31	32	32
Weight standard	G [kg]	1,75		2,25		2,7	3,2	3,65
Radial load permitted at shaft end @ 3000 min ⁻¹	F_R [N]	350						
Axial load max. permitted	F_A [N]	85						
Motor number		00299R	00731R	00258R	00273R	00263R	00420R	00252R

Brake data

Data	Symbol [Unit]	Value
Holding torque	M_{BR} [Nm]	2,5
Operating voltage	U_{BR} [VDC]	24 +15 / -0 %
electrical power	P_{BR} [W]	12
Moment of inertia	J_{BR} [kgcm ²]	0,38
Release delay time	t_{BRH} [ms]	10-15
Application delay time	t_{BRL} [ms]	10-15
Weight of the brake	G_{BR} [kg]	0,4

Connections and leads

Data	DBL3 N00065	DBL3 H00065	DBL3 N00130	DBL3 H00130	DBL3 M00190	DBL3 H00250	DBL3 N00300
Power connection	4 + 4 poles, round, angular						
Motor cable, shielded	4 x 1						
Motor cable with control leads, shielded	4 x 1 + 2 x 0,75						
Resolver connection	12 poles, round, angular						
Resolver cable, shielded	4 x 2 x 0,25mm ²						
Encoder connection (Option)	17 poles, round, angular						
Encoder cable, shielded	7 x 2 x 0,25mm ²						

Dimensions (drawing in principle)

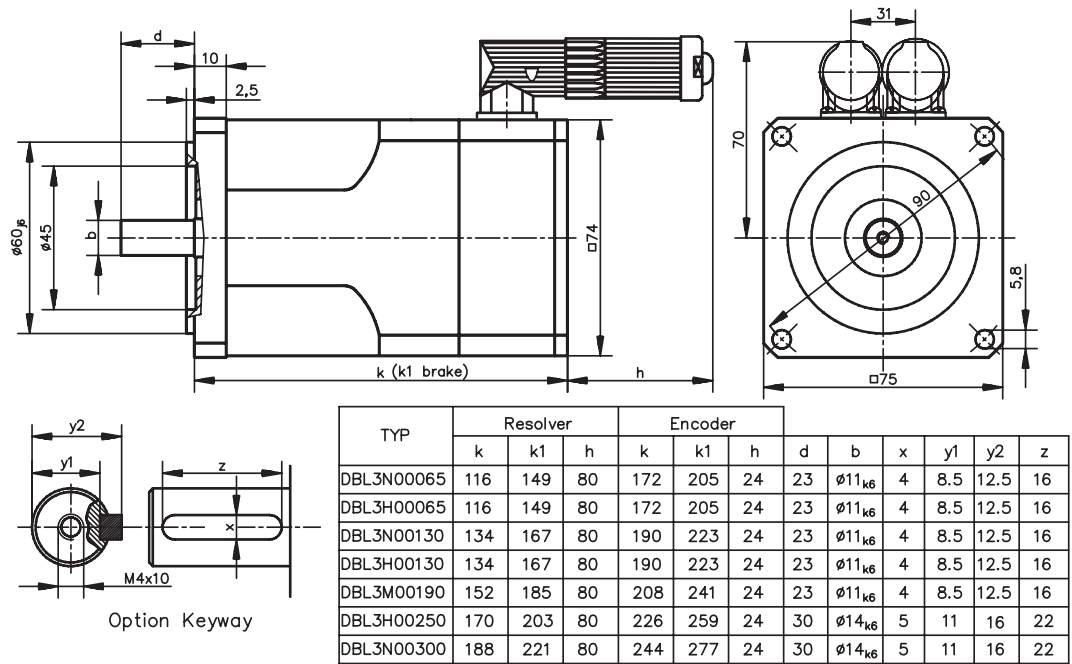

Radial forces at the shaft end

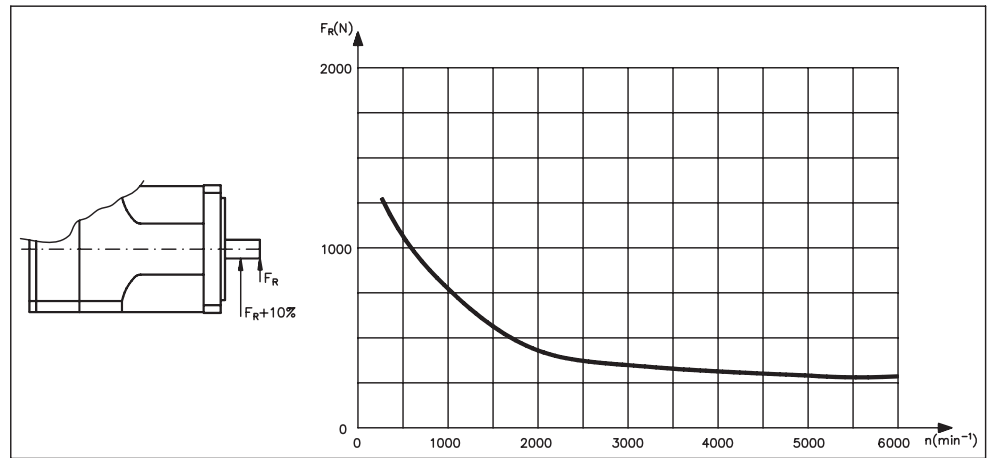

10.5 DBL4

The data can have a tolerance of +/- 10%.

Technical data

Data	Symbol [Unit]	DBL4 N00260	DBL4 H00260	DBL4 N00530	DBL4 H00530	DBL4 N00750	DBL4 H00750	DBL4 N00950
Electrical data								
Standstill torque	M ₀ [Nm]	2,6	2,6	5,3	5,3	7,5	7,5	9,5
Standstill current	I _{0rms} [A]	1,9	3,1	3,4	6,5	4,2	9,1	6,4
Mains voltage	U _N [VAC]	230-480						
U _N = 230V	Rated speed	n _n [min ⁻¹]	—	3000	—	3000	—	3000
	Rated torque	M _n [Nm]	—	2,3	—	4,6	—	6,4
	Rated current	I _n [A]	—	3	—	5,9	—	8,1
	Rated power	P _n [kW]	—	0,72	—	1,45	—	2,01
U _N = 400V	Rated speed	n _n [min ⁻¹]	3000	—	3000	—	3000	—
	Rated torque	M _n [Nm]	2,3	—	4,6	—	6,4	—
	Rated current	I _n [A]	1,85	—	3,1	—	3,8	—
	Rated power	P _n [kW]	0,72	—	1,45	—	2,04	—
U _N = 480V	Rated speed	n _n [min ⁻¹]	3600	—	3600	—	3600	—
	Rated torque	M _n [Nm]	2,2	—	4,4	—	6,25	—
	Rated current	I _n [A]	1,62	—	2,68	—	3,38	—
	Rated power	P _n [kW]	0,83	—	1,66	—	2,36	—
Peak current	I _{0max} [A]	11,5	18,9	20,2	39,5	25,2	54,4	38,3
Torque constant	K _{Trms} [Nm/A]	1,36	0,83	1,57	0,82	1,79	0,83	1,49
Voltage constant	K _{E rms} [mV/min]	82	50	95	49,5	108	50	90
Winding resistance Ph-Ph	R ₂₀ [Ω]	9,6	3,6	6,1	1,7	3,95	0,87	1,65
Winding inductance Ph-Ph	L [mH]	41,5	15,9	35,5	9,8	25,4	5,6	11,7
Mechanical data								
Rotor moment of inertia	J [kgcm ²]	1,9		2,7		4,2		6,1
Static friction torque	M _R [Nm]	0,10		0,12		0,15		0,20
Thermal time constant	t _{TH} [min]	60		64		66	66	68
Weight standard	G [kg]	4,5		5,6		7,7		10,5
Radial load permitted at shaft end @ 3000 min ⁻¹	F _R [N]	580						
Axial load max. permitted	F _A [N]	106						
Motor number		00301R	00285R	00261R	00284R	00267R	00609R	00470R

Brake data

Data	Symbol [Unit]	Value
Holding torque	M _{BR} [Nm]	5
Operating voltage	U _{BR} [VDC]	24 +15 / -0 %
electrical power	P _{BR} [W]	16
Moment of inertia	J _{BR} [kgcm ²]	1,06
Release delay time	t _{BRH} [ms]	10-30
Application delay time	t _{BRL} [ms]	5-15
Weight of the brake	G _{BR} [kg]	0,75

Connections and leads

Data	DBL4 N00260	DBL4 H00260	DBL4 N00530	DBL4 H00530	DBL4 N00750	DBL4 H00750	DBL4 N00950
Power connection	4 + 4 poles, round, angular						
Motor cable, shielded	4 x 1,5						
Motor cable with control leads, shielded	4 x 1 + 2 x 0,75						
Resolver connection	12 poles, round, angular						
Resolver cable, shielded	4 x 2 x 0,25mm ²						
Encoder connection (Option)	17 poles, round, angular						
Encoder cable, shielded	7 x 2 x 0,25mm ²						

Dimensions (drawing in principle)

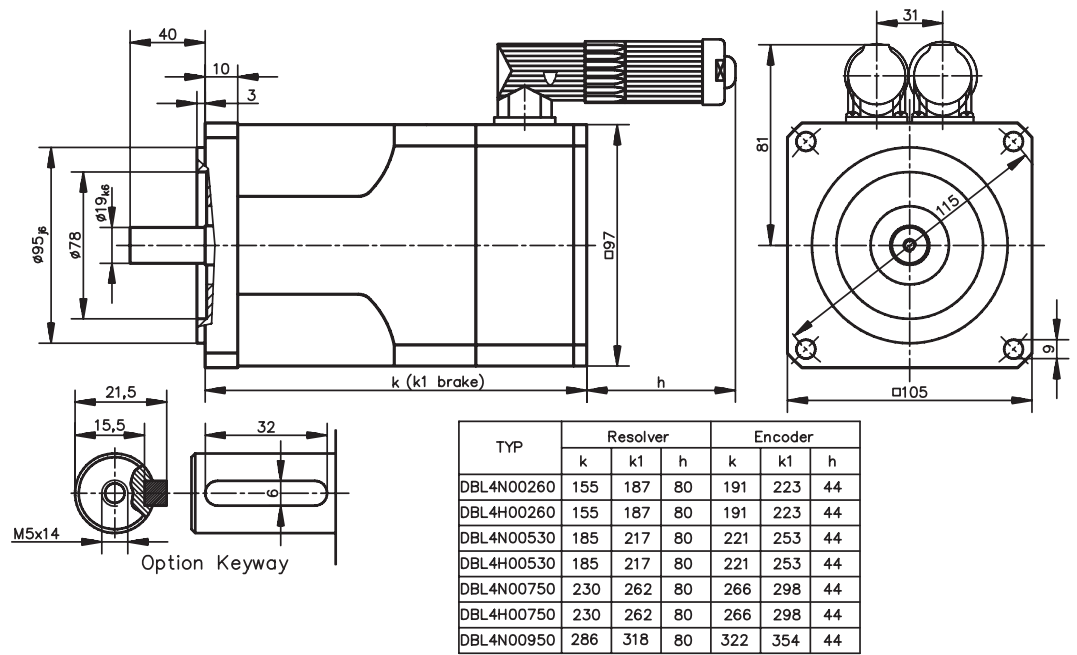

Radial forces at the shaft end

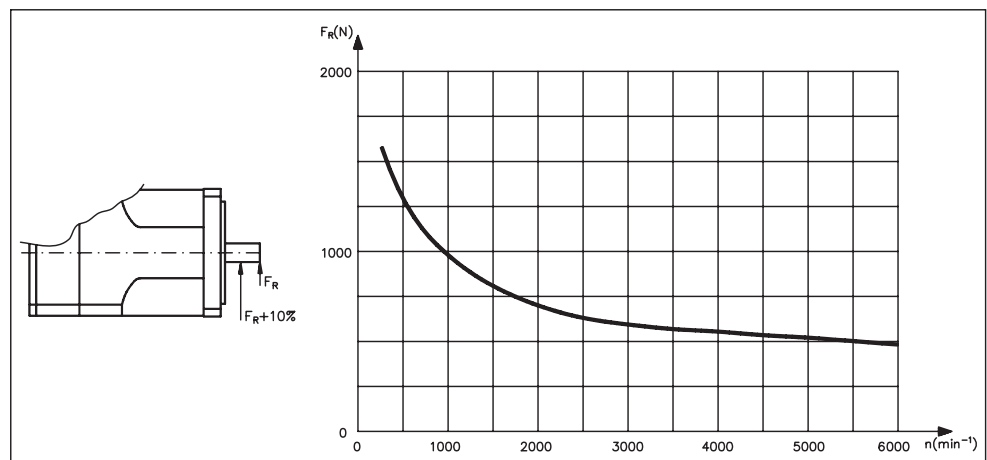

10.6

DBL5

The data can have a tolerance of +/- 10%.

Technical data

Data	Symbol [Unit]	DBL5 N01050	DBL5 H01050	DBL5 N01350	DBL5 H01350	DBL5 N01700	DBL5 H01700	DBL5 N02200
Electrical data								
Standstill torque	M ₀ [Nm]	10,5	10,5	13,5	13,5	17	17	22
Standstill current	I _{0rms} [A]	6,4	13,4	8,7	17,4	9,9	18,4	12,8
Mains voltage	U _N [VAC]	230-480						
U _N = 230V	Rated speed	n _n [min ⁻¹]	—	3000	—	3000	—	3000
	Rated torque	M _n [Nm]	—	8,8	—	11	—	14,5
	Rated current	I _n [A]	—	11,5	—	14,7	—	16
	Rated power	P _n [kW]	—	2,67	—	3,36	—	4,40
U _N = 400V	Rated speed	n _n [min ⁻¹]	3000	—	3000	—	3000	—
	Rated torque	M _n [Nm]	8,8	—	11	—	14,5	—
	Rated current	I _n [A]	5,5	—	7,3	—	8,6	—
	Rated power	P _n [kW]	2,67	—	3,36	—	4,40	—
U _N = 480V	Rated speed	n _n [min ⁻¹]	3600	—	3600	—	3600	—
	Rated torque	M _n [Nm]	8	—	10	—	13,4	—
	Rated current	I _n [A]	5	—	6,45	—	8,17	—
	Rated power	P _n [kW]	3,02	—	3,77	—	5,05	—
	Peak current	I _{0max} [A]	31,6	66,6	43,2	86,5	49,2	91,4
	Torque constant	K _{Trms} [Nm/A]	1,65	0,79	1,56	0,78	1,72	0,93
	Voltage constant	K _{Erms} [mVmin]	100	47,5	94	47	104	56
	Winding resistance Ph-Ph	R ₂₀ [Ω]	2,25	0,55	1,55	0,39	1,26	0,36
	Winding inductance Ph-Ph	L [mH]	20	4,6	14,6	3,6	13,3	3,7
Mechanical data								
	Rotor moment of inertia	J [kgcm ²]	6,2		7,3		9,5	11,7
	Static friction torque	M _R [Nm]	0,25		0,30		0,30	0,40
	Thermal time constant	t _{TH} [min]	50		55		60	75
	Weight standard	G [kg]	10		11,2		13,7	16,2
	Radial load permitted at shaft end @ 3000 min ⁻¹	F _R [N]	640					
	Axial load max. permitted	F _A [N]	111					
	Motor number		00666R	00562R	00576R	00633R	00665R	00661R
							00620R	

Brake data

Data	Symbol [Unit]	Value
Holding torque	M _{BR} [Nm]	12
Operating voltage	U _{BR} [VDC]	24 +15 / -0 %
electrical power	P _{BR} [W]	18
Moment of inertia	J _{BR} [kgcm ²]	3,6
Release delay time	t _{BRH} [ms]	30-60
Application delay time	t _{BRL} [ms]	10-20
Weight of the brake	G _{BR} [kg]	1,5

Connections and leads

Data	DBL5 N01050	DBL5 H01050	DBL5 N01350	DBL5 H01350	DBL5 N01700	DBL5 H01700	DBL5 N02200
Power connection	4 + 4 poles, round, angular						
Motor cable, shielded	4 x 1,5	4 x 2,5	4 x 1,5	4 x 2,5	4 x 1,5		4 x 2,5
Motor cable with control leads, shielded	4 x 1,5 + 2 x 0,75	4 x 2,5 + 2 x 1	4 x 1,5 + 2 x 0,75	4 x 2,5 + 2 x 1	4 x 1,5 + 2 x 0,75		4 x 2,5 + 2 x 1
Resolver connection	12 poles, round, angular						
Resolver cable, shielded	4 x 2 x 0,25mm ²						
Encoder connection (Option)	17 poles, round, angular						
Encoder cable, shielded	7 x 2 x 0,25mm ²						

Dimensions (drawing in principle)

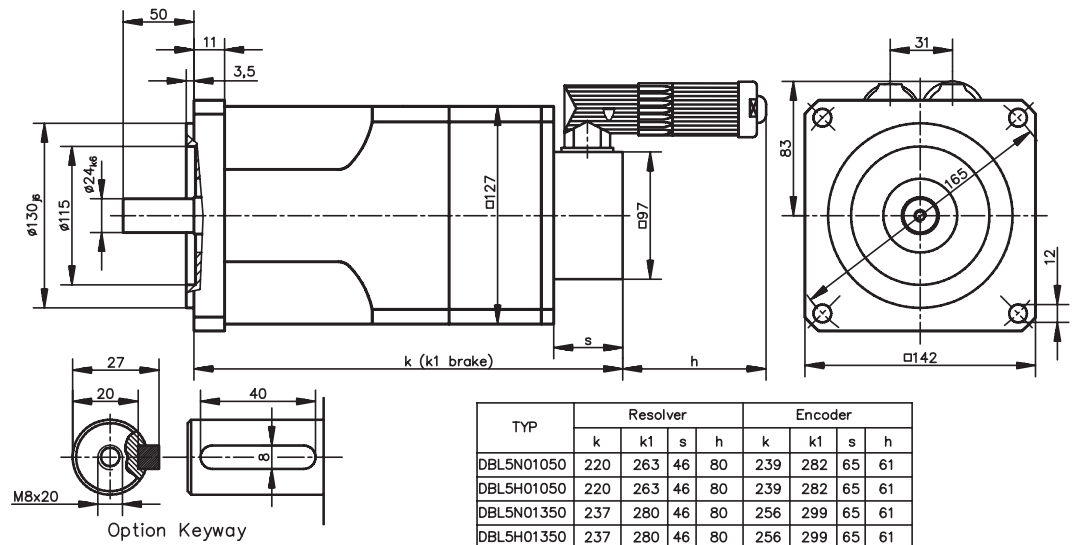

Radial forces at the shaft end

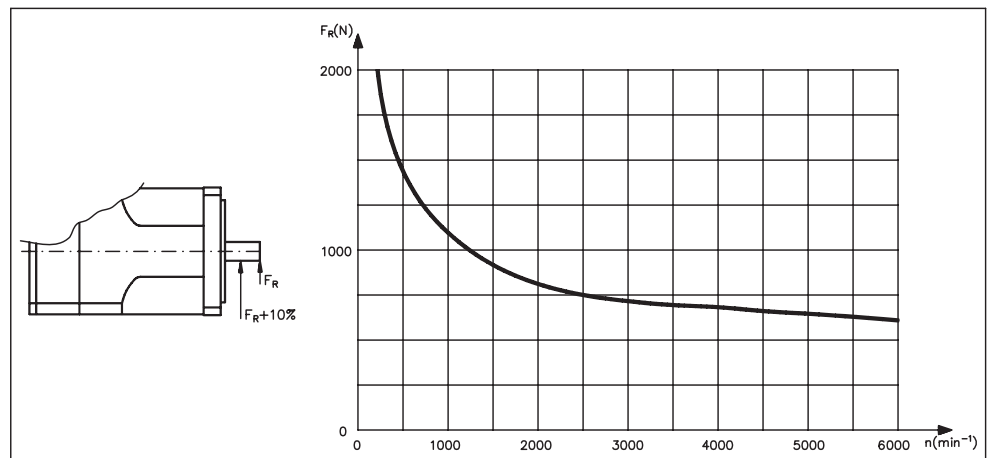

10.7

DBL6

The data can have a tolerance of +/- 10%.

Technical data

Data		Symbol [Unit]	DBL6 N02200	DBL6 N02900
Electrical data				
	Standstill torque	M_0 [Nm]	22	29
	Standstill current	I_{0rms} [A]	14,9	16,2
	Mains voltage	U_N [VAC]	400-480	
$U_N = 230V$	Rated speed	n_n [min ⁻¹]	—	—
	Rated torque	M_n [Nm]	—	—
	Rated current	I_n [A]	—	—
	Rated power	P_n [kW]	—	—
$U_N = 400V$	Rated speed	n_n [min⁻¹]	3000	3000
	Rated torque	M_n [Nm]	16	22
	Rated current	I_n [A]	11,8	13,6
	Rated power	P_n [kW]	5,03	6,28
$U_N = 480V$	Rated speed	n_n [min ⁻¹]	3600	3600
	Rated torque	M_n [Nm]	14,8	18,4
	Rated current	I_n [A]	10,1	11,2
	Rated power	P_n [kW]	5,58	6,94
	Peak current	I_{0max} [A]	74,8	80,8
	Torque constant	K_{Trms} [Nm/A]	1,47	1,79
	Voltage constant	K_{Erms} [mVmin]	89	108
	Winding resistance Ph-Ph	R_{20} [Ω]	0,74	0,55
	Winding inductance Ph-Ph	L [mH]	9,2	8
Mechanical data				
	Rotor moment of inertia	J [kgcm ²]	18,8	29,8
	Static friction torque	M_R [Nm]	0,40	0,40
	Thermal time constant	t_{TH} [min]	60	70
	Weight standard	G [kg]	17,3	24,4
	Radial load permitted at shaft end @ 3000 min ⁻¹	F_R [N]	680	
	Axial load max. permitted	F_A [N]	111	
	Motor number		00332R	00407R

Brake data

Data	Symbol [Unit]	Value
Holding torque	M_{BR} [Nm]	20
Operating voltage	U_{BR} [VDC]	24 +15 / -0 %
electrical power	P_{BR} [W]	22
Moment of inertia	J_{BR} [kgcm ²]	9,5
Release delay time	t_{BRH} [ms]	20-60
Application delay time	t_{BRL} [ms]	10-35
Weight of the brake	G_{BR} [kg]	2,75

Connections and leads

Data	DBL6 N02200	DBL6 N02900
Power connection	4 + 4 poles, round, angular	
Motor cable, shielded	4 x 2,5	
Motor cable with control leads, shielded	4 x 2,5 + 2 x 1	
Resolver connection	12 poles, round, angular	
Resolver cable, shielded	4 x 2 x 0,25mm ²	
Encoder connection (Option)	17 poles, round, angular	
Encoder cable, shielded	7 x 2 x 0,25mm ²	

Dimensions (drawing in principle)

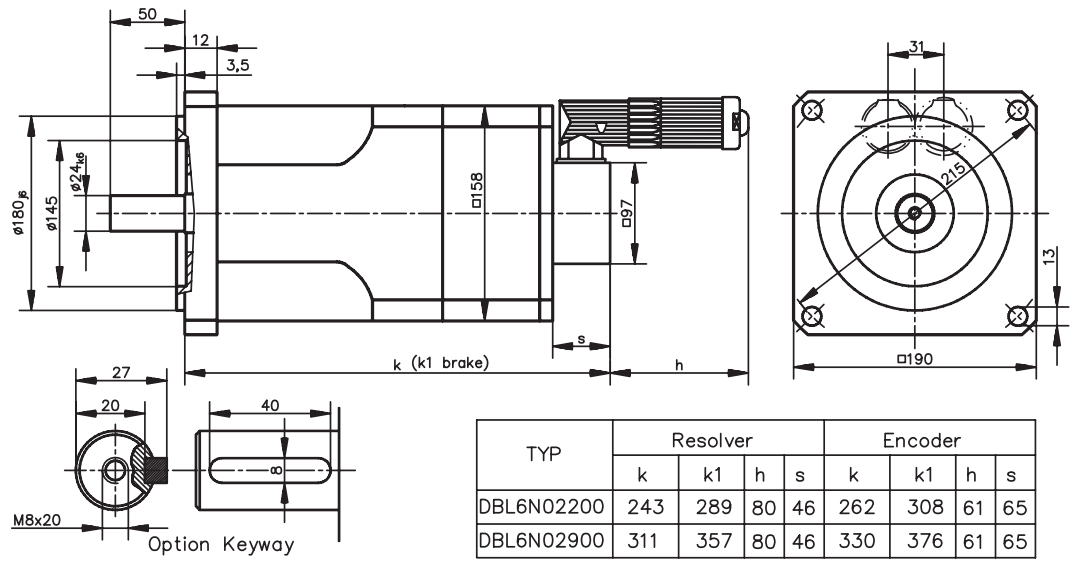

Radial forces at the shaft end

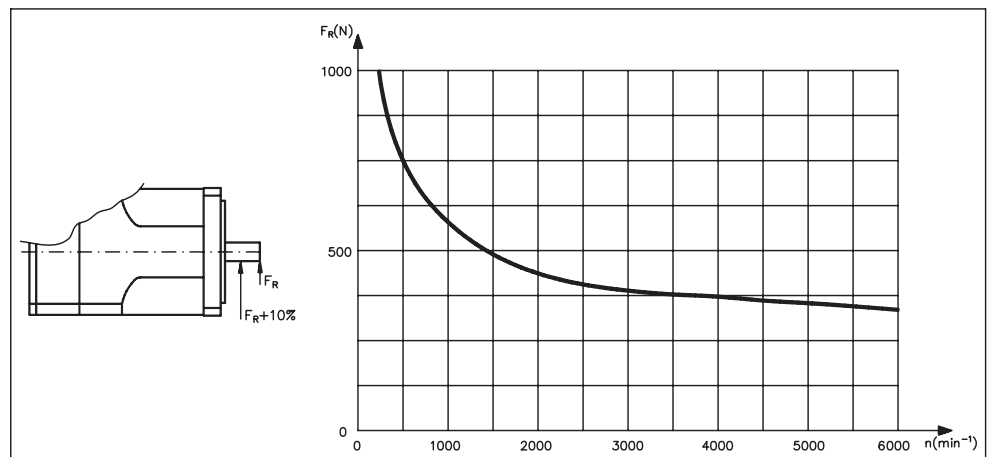

10.8

DBL7

The data can have a tolerance of +/- 10%.

Technical data

Data		Symbol [Unit]	DBL7 N02600	DBL7 N03200	DBL7 N04000
Electrical data					
	Standstill torque	M_0 [Nm]	26	32	40
	Standstill current	I_{0rms} [A]	16,9	19,7	23,9
	Mains voltage	U_N [VAC]	400-480		
$U_N = 230V$	Rated speed	n_n [min ⁻¹]	—	—	—
	Rated torque	M_n [Nm]	—	—	—
	Rated current	I_n [A]	—	—	—
	Rated power	P_n [kW]	—	—	—
$U_N = 400V$	Rated speed	n_n [min⁻¹]	3000	3000	3000
	Rated torque	M_n [Nm]	20	23	26
	Rated current	I_n [A]	14,1	15,6	17,3
	Rated power	P_n [kW]	6,28	7,23	8,17
$U_N = 480V$	Rated speed	n_n [min ⁻¹]	3600	3600	3600
	Rated torque	M_n [Nm]	18,8	21	23,2
	Rated current	I_n [A]	12,3	13,1	13,6
	Rated power	P_n [kW]	7,09	7,92	8,75
	Peak current	I_{0max} [A]	65,9	77	93
	Torque constant	K_{Trms} [Nm/A]	1,54	1,62	1,67
	Voltage constant	K_{Erms} [mVmin]	93	98	101
	Winding resistance Ph-Ph	R_{20} [Ω]	0,46	0,36	0,27
	Winding inductance Ph-Ph	L [mH]	5,1	4,2	3,4
Mechanical data					
	Rotor moment of inertia	J [kgcm ²]	67	81	101
	Static friction torque	M_R [Nm]	0,40	0,50	0,60
	Thermal time constant	t_{TH} [min]	60	67	70
	Weight standard	G [kg]	22,3	26,2	32
	Radial load permitted at shaft end @ 3000 min ⁻¹	F_R [N]	780		
	Axial load max. permitted	F_A [N]	90		
	Motor number		00335R	00402R	00450R

Brake data

Data	Symbol [Unit]	Value
Holding torque	M_{BR} [Nm]	20
Operating voltage	U_{BR} [VDC]	24 +15 / -0 %
electrical power	P_{BR} [W]	22
Moment of inertia	J_{BR} [kgcm ²]	9,5
Release delay time	t_{BRH} [ms]	20-60
Application delay time	t_{BRL} [ms]	10-35
Weight of the brake	G_{BR} [kg]	3,3

Connections and leads

Data	DBL7 N02600	DBL7 N03200	DBL7 N04000
Power connection	Terminal box		
Motor cable, shielded	4 x 2,5		4 x 4
Motor cable with control leads, shielded	4 x 2,5 + 2 x 1		—
Control leads, shielded	4 x 1		
Resolver connection	12 poles, round		
Resolver cable, shielded	4 x 2 x 0,25mm ²		
Encoder connection (Option)	17 poles, round		
Encoder cable, shielded	7 x 2 x 0,25mm ²		

10.9

DBL8

The data can have a tolerance of +/- 10%.

Technical data

Data		Symbol [Unit]	DBL8 N04000	DBL8 N06800	DBL8 L09300	DBL8 L11500
Electrical data						
	Standstill torque	M_0 [Nm]	40	68	93	115
	Standstill current	I_{0rms} [A]	21,8	35,8	33,1	42,1
	Mains voltage	U_N [VAC]	400-480			
$U_N = 230V$	Rated speed	n_n [min ⁻¹]	—	—	—	—
	Rated torque	M_n [Nm]	—	—	—	—
	Rated current	I_n [A]	—	—	—	—
	Rated power	P_n [kW]	—	—	—	—
$U_N = 400V$	Rated speed	n_n [min⁻¹]	3000	3000	2000	2000
	Rated torque	M_n [Nm]	30	50	70	85
	Rated current	I_n [A]	17,8	27,8	26	32,4
	Rated power	P_n [kW]	10,1	15,7	14,7	17,8
$U_N = 480V$	Rated speed	n_n [min ⁻¹]	3600	3600	—	—
	Rated torque	M_n [Nm]	30,4	45,6	—	—
	Rated current	I_n [A]	17,5	25	—	—
	Rated power	P_n [kW]	11,5	17,2	—	—
	Peak current	I_{0max} [A]	85	140	129	164
	Torque constant	K_{Trms} [Nm/A]	1,8	1,9	2,8	2,7
	Voltage constant	K_{Erms} [mVmin]	111	115	170	165
	Winding resistance Ph-Ph	R_{20} [Ω]	0,25	0,13	0,15	0,11
	Winding inductance Ph-Ph	L [mH]	5,7	3,3	4,8	3,4
Mechanical data						
	Rotor moment of inertia	J [kgcm ²]	76	114	153	190
	Static friction torque	M_R [Nm]	0,70	0,70	0,80	0,80
	Thermal time constant	t_{TH} [min]	47	65	79	90
	Weight standard	G [kg]	41	56	73	89
	Radial load permitted at shaft end @ 2000 min ⁻¹	F_R [N]	1800			
	Axial load max. permitted	F_A [N]	143			
	Motor number		00690R	00531R	00672R	00668R

Brake data

Data	Symbol [Unit]	Value
Holding torque	M_{BR} [Nm]	60
Operating voltage	U_{BR} [VDC]	24 +15 / -0 %
electrical power	P_{BR} [W]	36
Moment of inertia	J_{BR} [kgcm ²]	57,5
Release delay time	t_{BRH} [ms]	150
Application delay time	t_{BRL} [ms]	40
Weight of the brake	G_{BR} [kg]	5,4

Connections and leads

Data	DBL8 N04000	DBL8 N06800	DBL8 L09300	DBL8 L11500
Power connection	Terminal box			
Motor cable, shielded	4 x 4	4 x 10		
Control leads, shielded	4 x 1			
Resolver connection	12 poles, round			
Resolver cable, shielded	4 x 2 x 0,25mm ²			
Encoder connection (Option)	17 poles, round			
Encoder cable, shielded	7 x 2 x 0,25mm ²			

Dimensions (drawing in principle)

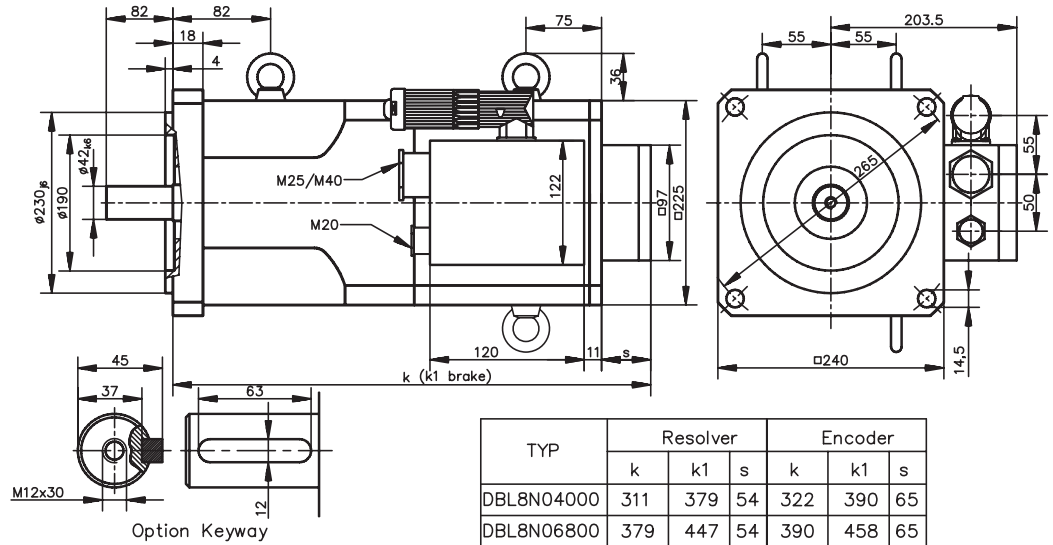

TYP	Resolver			Encoder		
	k	k1	s	k	k1	s
DBL8N04000	311	379	54	322	390	65
DBL8N06800	379	447	54	390	458	65
DBL8L09300	447	515	54	458	526	65
DBL8L11500	515	583	54	526	594	65

Radial forces at the shaft end

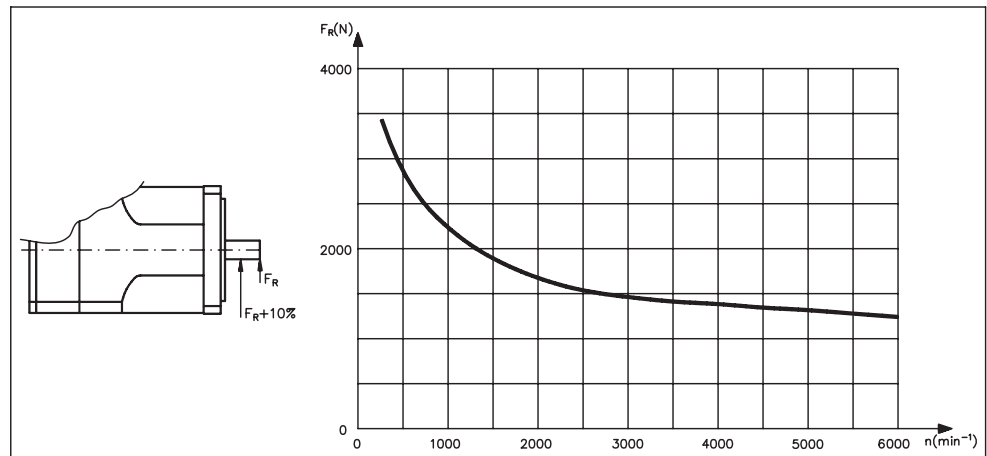

10.10 DBK4

The data can have a tolerance of +/- 10%.

Technical data

Data		Symbol [Unit]	DBK4 N00100	DBK4 H00100	DBK4 N00160	DBK4 H00160
Electrical data						
	Standstill torque	M_0 [Nm]	1	1	1,6	1,6
	Standstill current	I_{0rms} [A]	1,1	1,8	1,1	2
	Mains voltage	U_N [VAC]	230-480			
$U_N = 230V$	Rated speed	n_n [min ⁻¹]	—	3000	—	3000
	Rated torque	M_n [Nm]	—	0,9	—	1,35
	Rated current	I_n [A]	—	1,75	—	1,85
	Rated power	P_n [kW]	—	0,28	—	0,44
$U_N = 400V$	Rated speed	n_n [min ⁻¹]	3000	—	3000	—
	Rated torque	M_n [Nm]	0,9	—	1,35	—
	Rated current	I_n [A]	1,05	—	1	—
	Rated power	P_n [kW]	0,28	—	0,44	—
$U_N = 480V$	Rated speed	n_n [min ⁻¹]	3600	—	3600	—
	Rated torque	M_n [Nm]	0,88	—	1,35	—
	Rated current	I_n [A]	0,95	—	0,91	—
	Rated power	P_n [kW]	0,33	—	0,5	—
	Peak current	I_{0max} [A]	6,4	10,8	6,4	12,1
	Torque constant	K_{Trms} [Nm/A]	0,94	0,55	1,51	0,79
	Voltage constant	K_{Erms} [mVmin]	57	33,3	91	48
	Winding resistance Ph-Ph	R_{20} [Ω]	36,3	13	25,9	7,4
	Winding inductance Ph-Ph	L [mH]	75	25	82	22,7
Mechanical data						
	Rotor moment of inertia	J [kgcm ²]	0,54		1,28	
	Static friction torque	M_R [Nm]	0,10		0,13	
	Thermal time constant	t_{TH} [min]	45		50	50
	Weight standard	G [kg]	2,6			
	Radial load permitted at shaft end @ 3000 min ⁻¹	F_R [N]	590			
	Axial load max. permitted	F_A [N]	106			
	Motor number		00259R	00017R	00441R	00347R

Brake data

Data	Symbol [Unit]	Value
Holding torque	M_{BR} [Nm]	2,5
Operating voltage	U_{BR} [VDC]	24 +15 / -0 %
electrical power	P_{BR} [W]	12
Moment of inertia	J_{BR} [kgcm ²]	0,38
Release delay time	t_{BRH} [ms]	10-15
Application delay time	t_{BRL} [ms]	10-15
Weight of the brake	G_{BR} [kg]	0,45

Connections and leads

Data	DBK4 N00100	DBK4 H00100	DBK4 N00160	DBK4 H00160
Power connection	4 + 4 poles, round, angular			
Motor cable, shielded	4 x 1			
Motor cable with control leads, shielded	4 x 1 + 2 x 0,75			
Resolver connection	12 poles, round, angular			
Resolver cable, shielded	4 x 2 x 0,25mm ²			
Encoder connection (Option)	17 poles, round, angular			
Encoder cable, shielded	7 x 2 x 0,25mm ²			

Dimensions (drawing in principle)

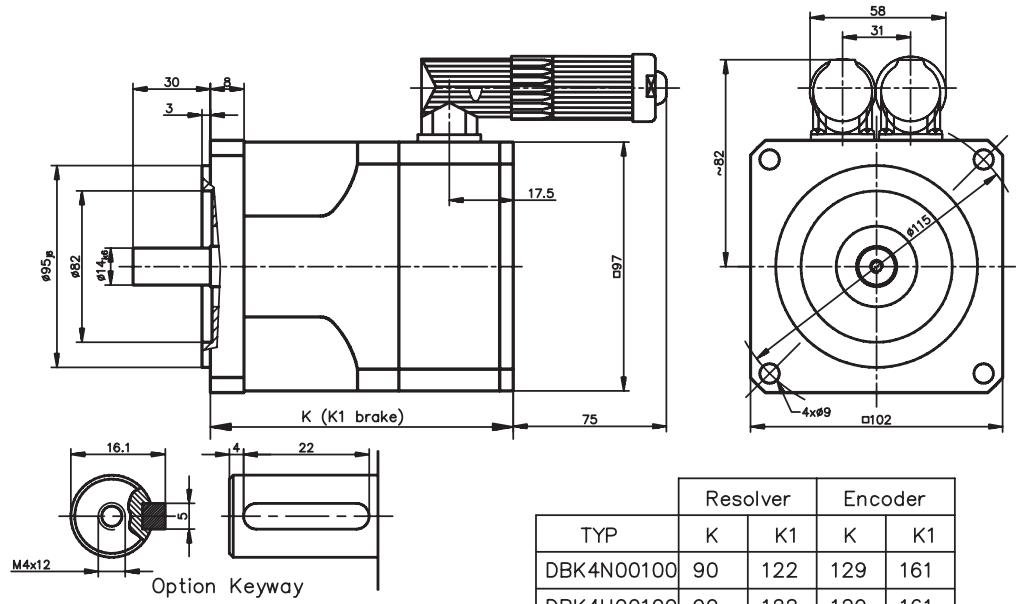

Radial forces at the shaft end

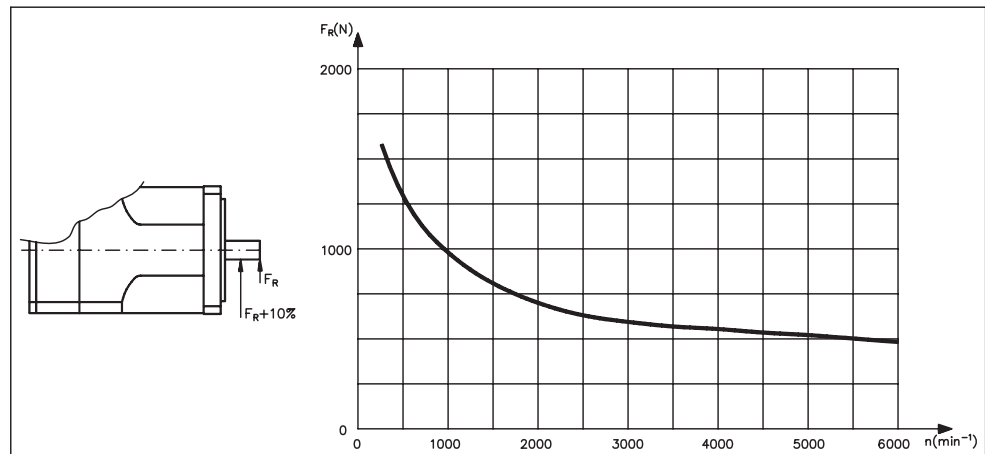

10.11

DBK5

The data can have a tolerance of +/- 10%.

Technical data

Data		Symbol [Unit]	DBK5 N00210	DBK5 H00210	DBK5 N00430	DBK5 H00430
Electrical data						
	Standstill torque	M_0 [Nm]	2,1	2,1	4,3	4,3
	Standstill current	I_{0rms} [A]	1,6	4	3	5,2
	Mains voltage	U_N [VAC]	230-480			
$U_N = 230V$	Rated speed	n_n [min ⁻¹]	—	3000	—	3000
	Rated torque	M_n [Nm]	—	1,9	—	3,9
	Rated current	I_n [A]	—	3,95	—	5
	Rated power	P_n [kW]	—	0,60	—	1,23
$U_N = 400V$	Rated speed	n_n [min⁻¹]	3000	—	3000	—
	Rated torque	M_n [Nm]	1,9	—	3,9	—
	Rated current	I_n [A]	1,6	—	2,9	—
	Rated power	P_n [kW]	0,60	—	1,23	—
$U_N = 480V$	Rated speed	n_n [min ⁻¹]	3600	—	3600	—
	Rated torque	M_n [Nm]	1,8	—	3,8	—
	Rated current	I_n [A]	1,32	—	2,55	—
	Rated power	P_n [kW]	0,68	—	1,43	—
	Peak current	I_{0max} [A]	8,1	18,1	15	26
	Torque constant	K_{Trms} [Nm/A]	1,29	0,52	1,44	0,83
	Voltage constant	K_{Erms} [mV/min]	78	31,5	87	50
	Winding resistance Ph-Ph	R_{20} [Ω]	20,1	3	7,2	2,4
	Winding inductance Ph-Ph	L [mH]	75,5	11	35	11,5
Mechanical data						
	Rotor moment of inertia	J [kgcm ²]	2,5		5,78	
	Static friction torque	M_R [Nm]	0,15		0,20	
	Thermal time constant	t_{TH} [min]	33		34	
	Weight standard	G [kg]	5		6,8	
	Radial load permitted at shaft end @ 3000 min ⁻¹	F_R [N]	640			
	Axial load max. permitted	F_A [N]	111			
	Motor number		00374R	00549R	00375R	00345R

Brake data

Data	Symbol [Unit]	Value
Holding torque	M_{BR} [Nm]	5
Operating voltage	U_{BR} [VDC]	24 +15 / -0 %
electrical power	P_{BR} [W]	16
Moment of inertia	J_{BR} [kgcm ²]	1,06
Release delay time	t_{BRH} [ms]	10-30
Application delay time	t_{BRL} [ms]	5-15
Weight of the brake	G_{BR} [kg]	0,75

Connections and leads

Data	DBK5 N00210	DBK5 H00210	DBK5 N00430	DBK5 H00430
Power connection	4 + 4 poles, round, angular			
Motor cable, shielded	4 x 1			
Motor cable with control leads, shielded	4 x 1 + 2 x 0,75			
Resolver connection	12 poles, round, angular			
Resolver cable, shielded	4 x 2 x 0,25mm ²			
Encoder connection (Option)	17 poles, round, angular			
Encoder cable, shielded	7 x 2 x 0,25mm ²			

Dimensions (drawing in principle)

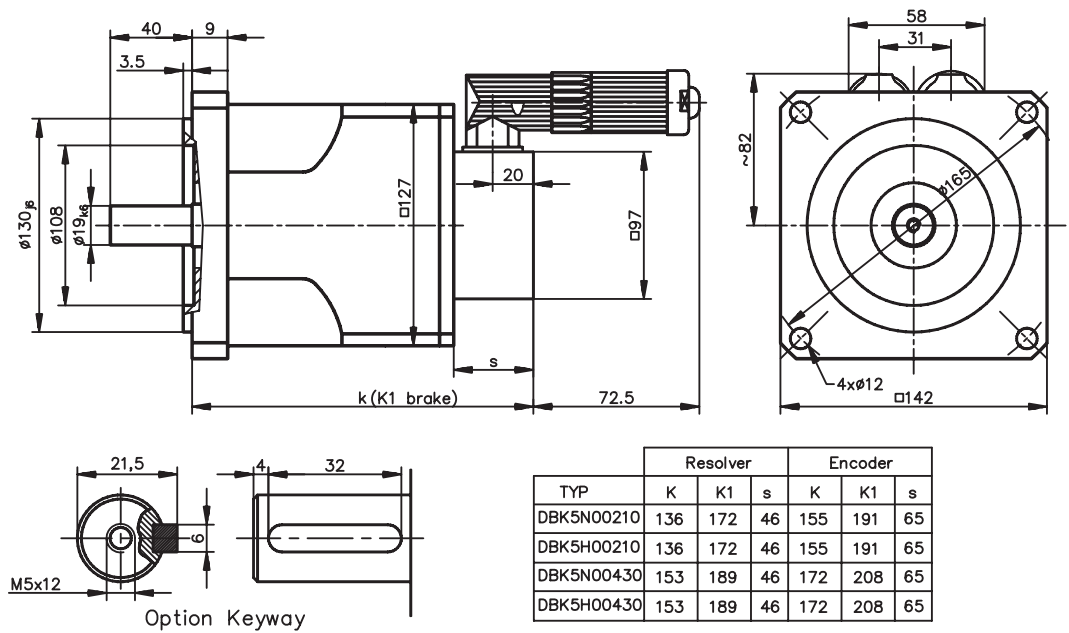

Radial forces at the shaft end

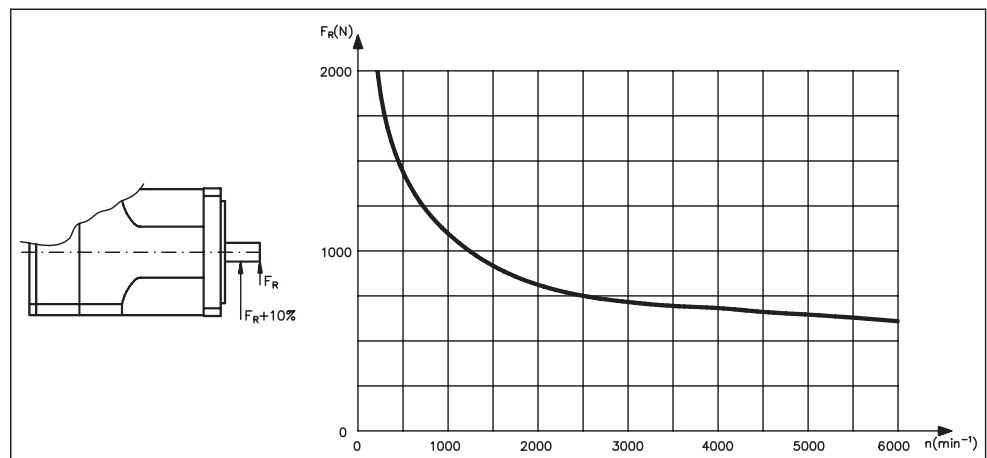

10.12

DBK6

The data can have a tolerance of +/- 10%.

Technical data

Data		Symbol [Unit]	DBK6 N00350	DBK6 N00700
Electrical data				
	Standstill torque	M_0 [Nm]	3,5	7
	Standstill current	I_{0rms} [A]	3	4,7
	Mains voltage	U_N [VAC]	400-480	
$U_N = 230V$	Rated speed	n_n [min ⁻¹]	—	—
	Rated torque	M_n [Nm]	—	—
	Rated current	I_n [A]	—	—
	Rated power	P_n [kW]	—	—
$U_N = 400V$	Rated speed	n_n [min⁻¹]	3000	3000
	Rated torque	M_n [Nm]	3	6
	Rated current	I_n [A]	3	4,5
	Rated power	P_n [kW]	0,94	1,89
$U_N = 480V$	Rated speed	n_n [min ⁻¹]	3600	3600
	Rated torque	M_n [Nm]	2,9	5,7
	Rated current	I_n [A]	2,3	4,1
	Rated power	P_n [kW]	1,09	2,15
	Peak current	I_{0max} [A]	15,1	23,5
	Torque constant	K_{Trms} [Nm/A]	1,16	1,49
	Voltage constant	K_{Erms} [mV/min]	70	90
	Winding resistance Ph-Ph	R_{20} [Ω]	8,8	4,45
	Winding inductance Ph-Ph	L [mH]	52	36
Mechanical data				
	Rotor moment of inertia	J [kgcm ²]	5,6	11,35
	Static friction torque	M_R [Nm]	0,30	0,30
	Thermal time constant	t_{TH} [min]	31	38
	Weight standard	G [kg]	6,9	8,7
	Radial load permitted at shaft end @ 3000 min ⁻¹	F_R [N]	650	
	Axial load max. permitted	F_A [N]	111	
	Motor number		00476R	00356R

Brake data

Data	Symbol [Unit]	Value
Holding torque	M_{BR} [Nm]	5
Operating voltage	U_{BR} [VDC]	24 +15 / -0 %
electrical power	P_{BR} [W]	16
Moment of inertia	J_{BR} [kgcm ²]	1,06
Release delay time	t_{BRH} [ms]	10-30
Application delay time	t_{BRL} [ms]	5-15
Weight of the brake	G_{BR} [kg]	0,75

Connections and leads

Data	DBK6 N00350	DBK6 N00700
Power connection	4 + 4 poles, round, angular	
Motor cable, shielded	4 x 1	
Motor cable with control leads, shielded	4 x 1 + 2 x 0,75	
Resolver connection	12 poles, round, angular	
Resolver cable, shielded	4 x 2 x 0,25mm ²	
Encoder connection (Option)	17 poles, round, angular	
Encoder cable, shielded	7 x 2 x 0,25mm ²	

Dimensions (drawing in principle)

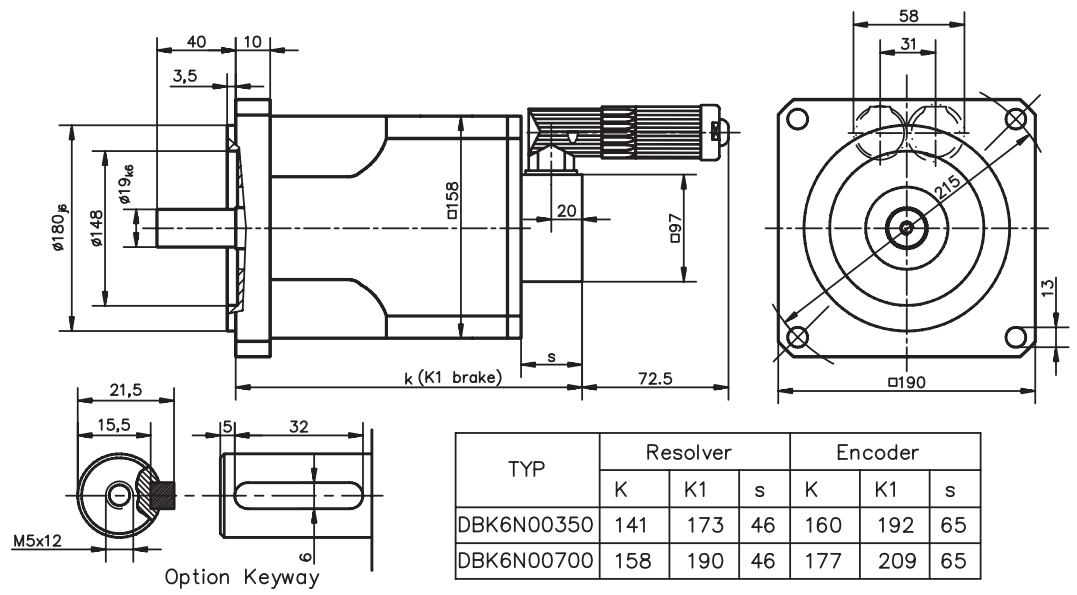

Radial forces at the shaft end

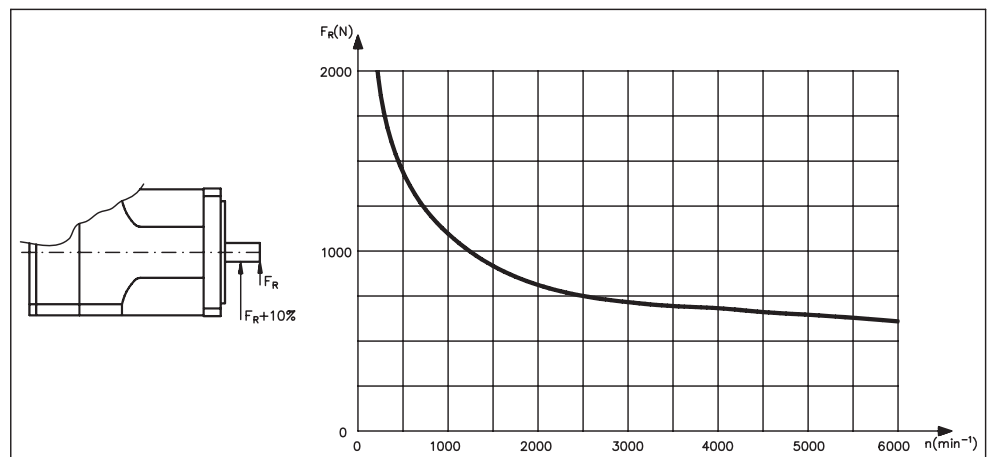

10.13

DBK7

The data can have a tolerance of +/- 10%.

Technical data

Data		Symbol [Unit]	DBK7 N00650	DBK7 N01200	DBK7 N01950
Electrical data					
	Standstill torque	M_0 [Nm]	6,5	12	19,5
	Standstill current	I_{0rms} [A]	4,5	7,5	11,8
	Mains voltage	U_N [VAC]	400-480		
$U_N = 230V$	Rated speed	n_n [min ⁻¹]	—	—	—
	Rated torque	M_n [Nm]	—	—	—
	Rated current	I_n [A]	—	—	—
	Rated power	P_n [kW]	—	—	—
$U_N = 400V$	Rated speed	n_n [min ⁻¹]	3000	3000	3000
	Rated torque	M_n [Nm]	5	10	15
	Rated current	I_n [A]	4	6,8	10
	Rated power	P_n [kW]	1,57	3,14	4,71
$U_N = 480V$	Rated speed	n_n [min ⁻¹]	3600	3600	3600
	Rated torque	M_n [Nm]	4,7	9,6	14
	Rated current	I_n [A]	3,3	5,96	8,48
	Rated power	P_n [kW]	1,77	3,62	5,28
	Peak current	I_{0max} [A]	17,6	27	46
	Torque constant	K_{Trms} [Nm/A]	1,44	1,6	1,65
	Voltage constant	K_{Erms} [mVmin]	87	97	100
	Winding resistance Ph-Ph	R_{20} [Ω]	4,2	1,6	0,8
	Winding inductance Ph-Ph	L [mH]	27	13	8,3
Mechanical data					
	Rotor moment of inertia	J [kgcm ²]	32,36	36	69,16
	Static friction torque	M_R [Nm]	0,35	0,40	0,50
	Thermal time constant	t_{TH} [min]	35	42	52
	Weight standard	G [kg]	10	14	19
	Radial load permitted at shaft end @ 3000 min ⁻¹	F_R [N]	690		
	Axial load max. permitted	F_A [N]	90		
	Motor number		00377R	00378R	00379R

Brake data

Data	Symbol [Unit]	Value
Holding torque	M_{BR} [Nm]	12
Operating voltage	U_{BR} [VDC]	24 +15 / -0 %
electrical power	P_{BR} [W]	18
Moment of inertia	J_{BR} [kgcm ²]	3,6
Release delay time	t_{BRH} [ms]	30-60
Application delay time	t_{BRL} [ms]	10-20
Weight of the brake	G_{BR} [kg]	1,5

Connections and leads

Data	DBK7 N00650	DBK7 N01200	DBK7 N01950
Power connection	4 + 4 poles, round, angular		
Motor cable, shielded	4 x 1,5		
Motor cable with control leads, shielded	4 x 1,5 + 2 x 0,75		
Resolver connection	12 poles, round, angular		
Resolver cable, shielded	4 x 2 x 0,25mm ²		
Encoder connection (Option)	17 poles, round, angular		
Encoder cable, shielded	7 x 2 x 0,25mm ²		

Dimensions (drawing in principle)

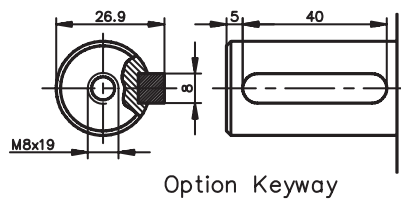
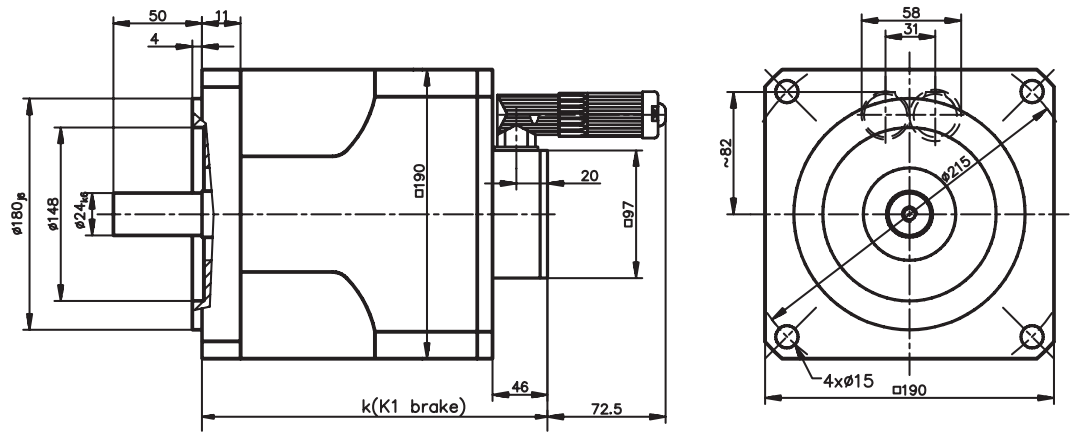

Option Keyway

TYP	Resolver		Encoder	
	K	K1	K	K1
DBK7N00650	152	190	171	209
DBK7N01200	175	213	194	232
DBK7N01950	198	236	217	255

Radial forces at the shaft end

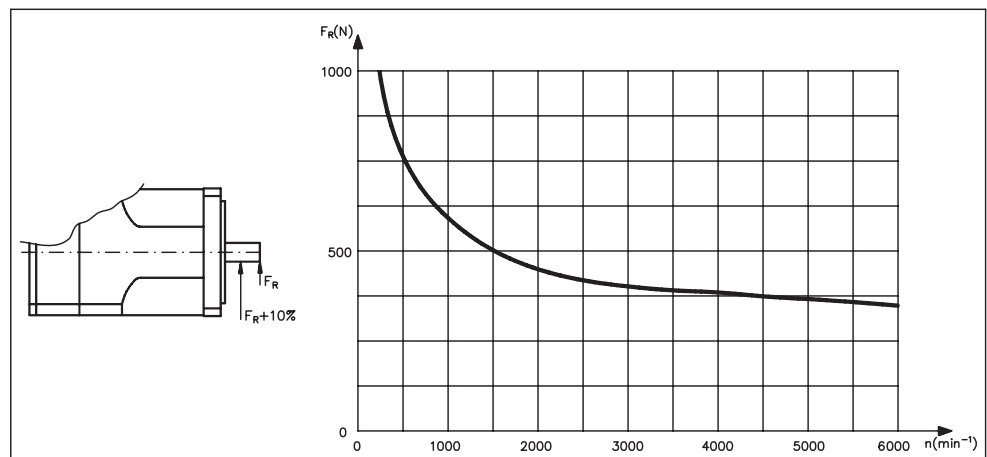

11 Appendix

11.1 Assignment of RediMount gearhead mounts

Motor	RediMount	Flange length in. (mm)	Motor	RediMount	Flange length in. (mm)	
DBL2x	RM060-7	1.22 (31.0)	DBK4x	RM060-49B	1.95 (49.5)	
		RM075-7		in preparation		RM075-49B
DBL3x (11mm shaft)	RM060-57	1.22 (31.0)		RM090-49B	1.74 (44.1)	
		RM075-57	1.69 (42.9)		RM100-49B	TBD
		RM090-57A	1.74 (44.1)		RM115-49B	1.93 (48.9)
DBL3x (14mm shaft)	RM060-25	1.22 (31.0)	DBK5x	RM115-84	23.6 (59.9)	
		RM075-25	1.69 (42.9)		RM142-84	3.21 (81.5)
		RM090-25	1.74 (44.1)		RM180-84	3.60 (91.4)
		RM100-25	1.72 (43.7)		RM220-84	in preparation
		RM115-25	1.93 (48.9)	DBK6x	RM142-XXX	in preparation
DBL4x	RM075-52A	1.69 (42.9)		RM180-XXX	3.60 (91.4)	
		RM090-52A	1.74 (44.1)		RM220-XXX	2.74 (69.6)
		RM100-52	1.72 (43.7)	DBK7x	RM180-317	3.60 (91.4)
		RM115-52	2.36 (59.9)		RM220-317	2.74 (69.6)
		RM142-52	2.74 (69.6)			
DBL5x	RM115-88	2.36 (59.9)				
		RM142-88	3.21 (81.5)			
		RM180-88	3.60 (91.4)			
		RM220-88	in preparation			
DBL6x	RM180-XXX	3.60 (91.4)				
	RM220-XXX	2.74 (69.6)				
DBL7x	RM142-107	3.36 (85.3)				
		RM180-107	3.60 (91.4)			
		RM220-107	2.74 (69.6)			
DBL8x	RM220-119	3.35 (85.1)				

11.2 Assignment of Micron Gearheads to RediMount mounts

These gearheads can be fitted to RediMount:

RediMount Mount	Micron gearhead
RM060	DT60, DTR60, DTRS60, DTRH60, NT23, NTP23, NT60, NTR23, UT006, UTR006, EQ23, EQ60
RM075	UT075, UTR075, UT090, UTR090
RM090	DT90, DTR90, DTRS90, DTRD90, DTRH90, NT34, NTP34, NT90, NTR34
RM100	UT010, UTR010, ET010, UT115, UTR115
RM115	DT115, DTR115, DTRS115, DTRD115, DTRH115, NT42, NTP42, NT115, NTR42
RM142	DT142, DTR142, DTRS142, DTRD142, DTRH142, NT142, UT014, UTR014, ET014
RM180	UT018, UTR018, ET018
RM220	UT220

You can find further information on Redimount and Micron gearheads on our website.

11.3 Index

A	Abbreviations	5	N	Nameplate	10
	Ambient temperature	12	O	Options	15
	Axial force	13	P	Packaging	9
B	Break response times	25		Peak current	25
C	Cleaning	9		Pin assignment	21
	Connection method	14		Pole number	14
	Coupling	13		Power derating	12
D	DBK4	42		Protection class	13
	DBK5	44		Protective device	13
	DBK6	46	R	Radial force	13
	DBK7	48		Rated current	25
	DBL1	26		Rated torque	25
	DBL2	28		Resolver	14
	DBL3	30		Resolver cable	18
	DBL4	32		Rotor moment of inertia	25
	DBL5	34	S	Safety notes	6
	DBL6	36		Setup	23
	DBL7	38		Shaft end	13
	DBL8	40		Standstill current	25
	Delivery package	10		Standstill torque	25
	Disposal	9		Storage	9
E	EC Declaration of Conformity	8		Style	13
	Encoder	14		Symbols	5
F	Feedback unit	14	T	Target group	5
	Flange	13		Thermal time constant	25
G	Gearhead assignment	50		Thermostat	13
	Gearhead mount	50		Torque constant	25
	Ground symbol	17		Transport	9
H	Holding brake	14		Trouble shooting	24
I	Installation		U	Use as directed	7
	electrical	17	V	Vibration class	14
	mechanical	16		Voltage constant	25
	Insulation material class	13	W	Wiring diagrams	19
M	Maintenance	9			
	Model number	11			
	Motor cable	18			
	Motor design	12			

Service

We are committed to quality customer service. In order to serve in the most effective way, please contact your local sales representative for assistance.
If you are unaware of your local sales representative, please contact the Customer Support.

Europa

Kollmorgen Customer Support Europe

Internet www.kollmorgen.com

E-Mail technik@kollmorgen.com

Tel.: +49 (0)2102 - 9394 - 2250

Fax: +49 (0)2102 - 9394 - 3110

North America

Kollmorgen Customer Support North America

Internet www.kollmorgen.com

E-Mail support@kollmorgen.com

Tel.: +1 - 540 - 633 - 3545

Fax: +1 - 540 - 639 - 4162