

# SynqNet® Case Study

MRI & CT Applications

**INNOMEDIC** has introduced the latest innovation in medical assisted procedures. The Innomedic Magnetic Resonance Imaging (MRI) and Computed Tomography (CT) compatible assistance system allows interventions with image guided navigation to provide a level of precision and safety not seen in the market until now.

Designing the system was inherently challenging due to the compact work envelope of MRI and CT machines and because of the unique ways these machines produce images. Patient safety is the highest priority, and this meant giving the physician an intuitive interface to control the system and also implementing best-in-class servo components for a high level of accuracy. In addition, a fail-safe control architecture was a must for the system design.

Innomedic chose a SynqNet® servo control system system to meet the stringent requirements of the Innomedic assistance system. Innomedic's design criteria included an all-digital data rich communication path to control critical servo pneumatic axes.



SynqNet's all-digital network allowed for tremendous wiring reductions compared to  $\pm 10V$  analog systems and offered robust remote diagnostic capabilities. SynqNet was a perfect fit not only for performance motion control, but also for its remote diagnostic features and ability to remotely upgrade drive/motor firmware and configuration files easily. More importantly, SynqNet's "Self-Healing" fault tolerant feature in ring topology mode enables the system to go to a controlled safe-state in the event of a faulty connection or complete wire break between nodes anywhere in the system. No other motion network available today offers this level of safety and reliability. The Innomedic assistance system provides the highest factor of safety due to the nature of the servo system design.

With the use of Innomedic systems, image guided interventions in MRI and CT are more effective, faster, safer, and more economical. In CT guided interventions, the radiation dosages to the physician and patient are reduced.

In addition, the physician will be able to carry out corresponding operations or interventions without additional assistance which also reduces the overall cost of treatment.

Applications for the assistance system include percutaneous pain therapy, interstitial tumor therapy, biopsy, and LITT.

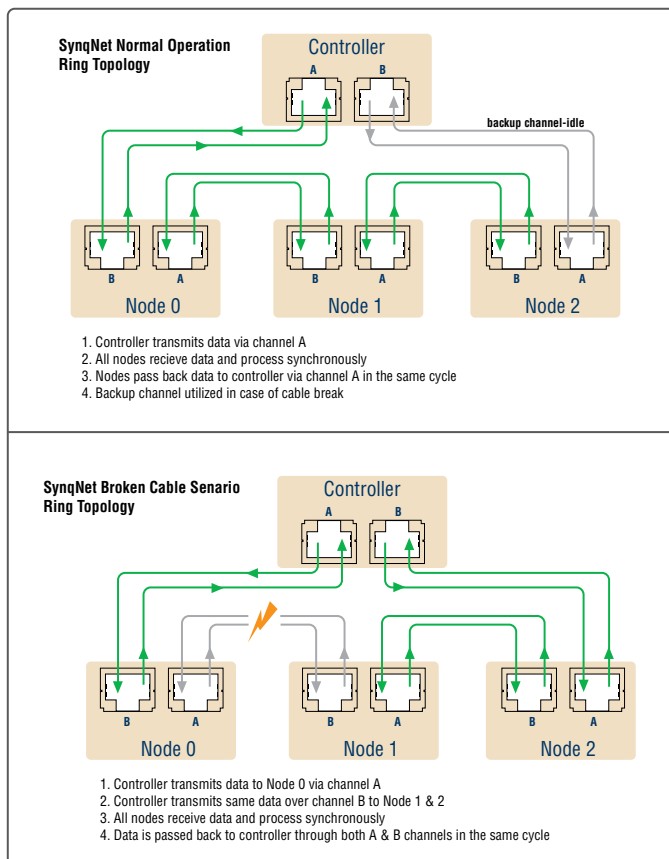

SynqNet® "Self-Healing" Fault Tolerance is a first in the motion control industry.

©2007 SynqNet. All rights reserved. Information & specifications subject to change at any time. All trademarks property of their respective owners. doc.innomedic040704

INNOMEDIC SynqNet®

www.innomedic.de  
info@innomedic.de  
+49 (0) 7276 / 9885.620

www.synqnet.org  
info@synqnet.org  
+1.805.879.0579