

MMC AND MMC FOR PC HARDWARE

This PDF document is a subset of the Sheffield Automation MMC Controls, Block I/O and Cimrex HMI Product Guide, P/N M.1301.6219.

NOTE

Progress is an ongoing commitment at Sheffield Automation. We continually strive to offer the most advanced products in the industry; therefore, information in this document is subject to change without notice. The illustrations and specifications are not binding in detail. Sheffield Automation shall not be liable for any technical or editorial omissions occurring in this document, nor for any consequential or incidental damages resulting from the use of this document.

DO NOT ATTEMPT to use any Sheffield Automation product until the use of such product is completely understood. It is the responsibility of the user to make certain proper operation practices are understood. Sheffield Automation products should be used only by qualified personnel and for the express purpose for which said products were designed.

Should information not covered in this document be required, contact the Customer Service Department, Sheffield Automation, 660 South Military Road, P.O. Box 1658, Fond du Lac, WI 54936-1658. Sheffield Automation can be reached by telephone at 920 921 7100.

Version 2.0

Copyright © 1999 - 2003 Sheffield Automation, LLC

Belden is a trademark of Cooper Industries, Inc.

Cimplicity is a trademark of GE FanucAutomation North America, Inc.

Cimrex is a trademark of Cimrex Electronic AB

Data Highway Plus is a trademark of Allen-Bradley Company

DeviceNet is a trademark of Iris Technologies, Inc.

IEEE is a trademark of the Institute of Electrical and Electronics Engineers

Intellution is a trademark of Intellution, Inc.

Modbus is a trademark of Gould, Inc.

Modicon is a trademark of Modicon Corporation

NEMA is a trademark of the National Energy Manufacturers Association

OPC OLE for Process Control is a trademark of OPC Foundation

Pentium is a trademark of Intel Corporation

RSView is a trademark of Rockwell Software, Inc.

Windows NT, Windows 2000 Windows XP, MS-DOS, QuickBASIC, and Microsoft are trademarks of Microsoft Corporation

Wonderware is a trademark of Wonderware Corporation

PiC900, PiC90, PiCPro, PiCServoPro, PiCMicroTerm, Centurion, and MMC are trademarks of Giddings & Lewis, LLC

Table of Contents: MMC and MMC for PC Hardware

MMC (Machine and Motion Control)	37
MMC (Machine and Motion Control)	39
MMC Mounting Instructions	46
MMC Accessories	47
MMC Breakout Box	47
MMC Breakout Box Cables	49
MMC Flying Lead Cables	49
MMC Specification Table	51
MMC Axis I/O Option Module	56
MMC Ethernet - TCP/IP Module	58
MMC DeviceNet Module	61
Introduction.....	61
Connections	62
The DeviceNet Port	63
The Configuration (RS232) Port.....	63
LEDs	64
Theory of Operation.....	65
Specifications.....	66
MMC Profibus Module	67
Introduction.....	67
Connections	68
The Profibus Port.....	69
The Configuration (RS232) Port.....	69
LEDs	70
Theory of Operation.....	71
MMC for PC (PC Machine and Motion Control)	73
MMC for PC (PC Machine and Motion Control)	74
MMC for PC	77
Analog Servo Interface Unit (ASIU).....	79
Optional Fieldbus Modules.....	87
Specification Tables.....	94

**MMC CONTROLS, BLOCK I/O AND CIMREX HMI
MOTION SOLUTIONS PRODUCT GUIDE**

MMC (Machine and Motion Control)

Sheffield Automation

MMC (Machine and Motion Control)



MMC family controls include the analog-interfaced MMC-A2 (2-1/2 axis) and MMC-A4 (4-1/2 axis), the MMC-A2 Plus (2-1/2 axis expandable to 18), and MMC-A4 Plus (4-1/2 axis, expandable to 20), and the SERCOS-interfaced MMC-S8 (8 axis) system.

Description. The MMC (Machine and Motion Control) is a compact, full-featured total machine control solution for applications requiring one to twenty axes of servo motion control. All three versions have the same compact footprint (9 inches tall, 2.125 inches wide and 5.25 inches deep).

Programming. The MMC is programmed using IEC61131 ladder logic, function blocks, and structured text. The same programming software, PiCPro for Windows, is used across the entire family of PiC and MMC products.

Features. Some of the powerful features that are available in PiCPro for Windows are animation, variable force and view, cam profiles, linear and circular interpolation, registration, multi-tasking, and UDFBs. With virtually no re-programming, an application can be loaded into an MMC, PiC90, or PiC900 control. This allows you to expand your motion control system from one product to another without wasting valuable engineering time.

Expanded Features. The MMC offers features and flexibility far beyond a typical motion controller, including total machine control capability, a single programming language for logic and motion, on-line edit of the motion program, Ethernet TCP/IP networking capability, distributed block I/O expansion, PLS outputs, and close-coupled logic and motion. The MMC is priced to be competitive with motion controllers, while offering a flexible, powerful total machine control solution instead of motion only.

Expandability. The MMC is expandable by using the Ethernet TCP/IP and/or Fieldbus (DeviceNet or Profibus) field-installable expansion modules. The Ethernet TCP/IP expan-

MMC (Machine and Motion Control)

sion module can be used for distributed control as well as remote troubleshooting over the Internet. The Fieldbus module is a master or scanner module that is used to scan the I/O on a DeviceNet or Profibus network.

Quick Start Example Programs. Included with PiCPro for Windows are several application example programs for the MMC to get you started in a matter of minutes. You can build off of these applications and customize them for your machine.

Processor. The MMC processor provides 256K of application memory and 128K of RAM-DISK memory. The processor has floating point capability. There is 2 Megabytes of flash memory resident on the CPU to store the source code for your application using the Project Manager. The system firmware is also stored in flash memory and is software-loadable.

Axis A1 to A4 Connectors. On the analog MMC, each axis connector (labeled A1 to A4) provides a connection to a servo amplifier. Each axis connector contains a differential encoder input, a +/- 10V analog output, two 24VDC discrete outputs for drive enable and drive reset, and one 24VDC discrete input for the drive ready or drive OK signal. Only one cable is required to interface an MMC to MMC Smart Drive amplifier. Encoder inputs and analog outputs not used for closed loop servos can be used for variable frequency drives or additional master axes.

Aux I/O. On the analog MMC, the Aux I/O connector contains the fast inputs for each axis (including the half axis encoder input) for registration and hardware interrupt capability. It also contains the differential encoder input for the half axis, one analog input, and three 24VDC discrete inputs for each closed loop axis. Typically these inputs would be used for plus and minus end of travel limits and for the reference switch. However, they can be used as general purpose inputs if they are not being used for end-of-travel and reference switch.

Input Power. The MMC input power is a 24V screw terminal connection.

Gen I/O. The Gen I/O connector contains sixteen general-purpose 24 VDC discrete inputs (sink or source) and sixteen general-purpose 24 VDC discrete outputs (source only). Any of the 16 outputs can be used as CAM or PLS outputs. Two of the inputs (number 1 and number 9) have hardware interrupt capability and can be used to trigger hardware interrupt tasks in the application program.

User Port. The user port connector is a serial port typically used for a Cimrex operator interface. This port has multi-drop capability (RS232, RS422, or RS485) and can run at baud rates up to 19.2K baud.

Block I/O. The Block I/O connector is used for communicating with distributed block I/O modules. Up to 77 blocks can be connected to a single MMC. A complete family of block I/O modules are available, including AC and DC discrete I/O, analog I/O, stepper and resolver.

PiCPro Connector. The PiCPro connector is used for communicating with a PC when running PiCPro for Windows.

Cables. There are a number of plug and play cables available to facilitate MMC field wiring. Three connector types of cables can be used with the A1 to A4 connectors, including an MMC Smart Drive, a flying lead connector, or a breakout box connector. For the AUX I/O, GEN I/O, USER PORT, and BLOCK I/O connectors, there are two types of cables that can be used: A breakout box connector or a flying lead connector. For the PiCPro connector, the standard PiCPro cable is used.

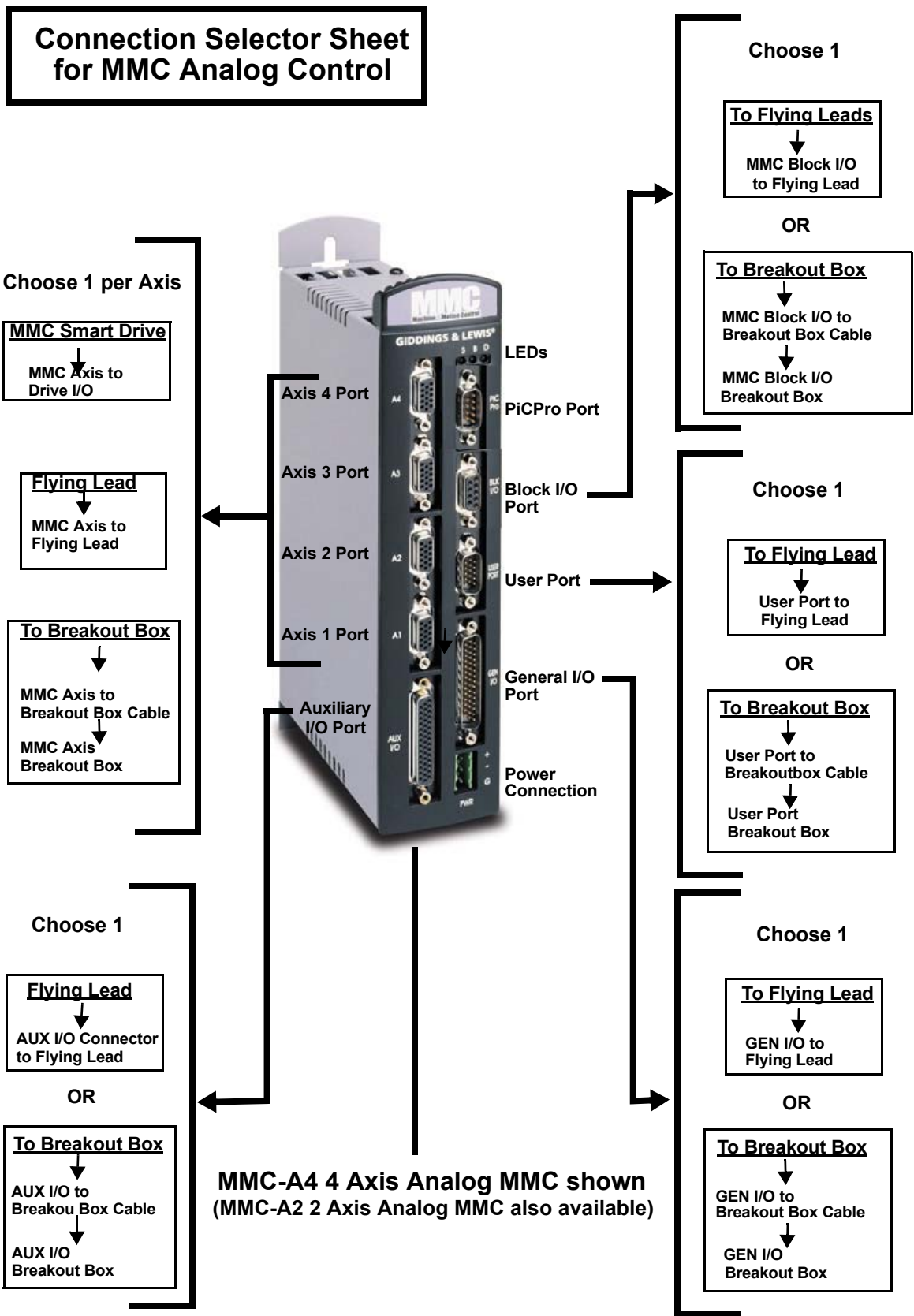

**Connection Selector Sheet
for MMC SERCOS Control**

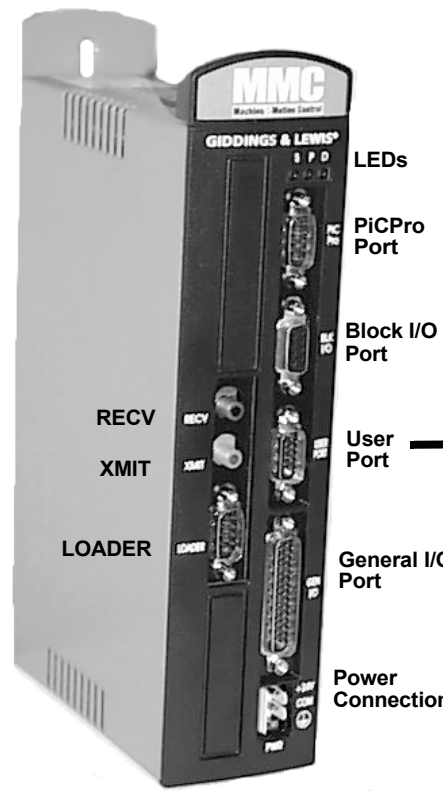

**MMC-S8 8 Axis
SERCOS MMC Control**

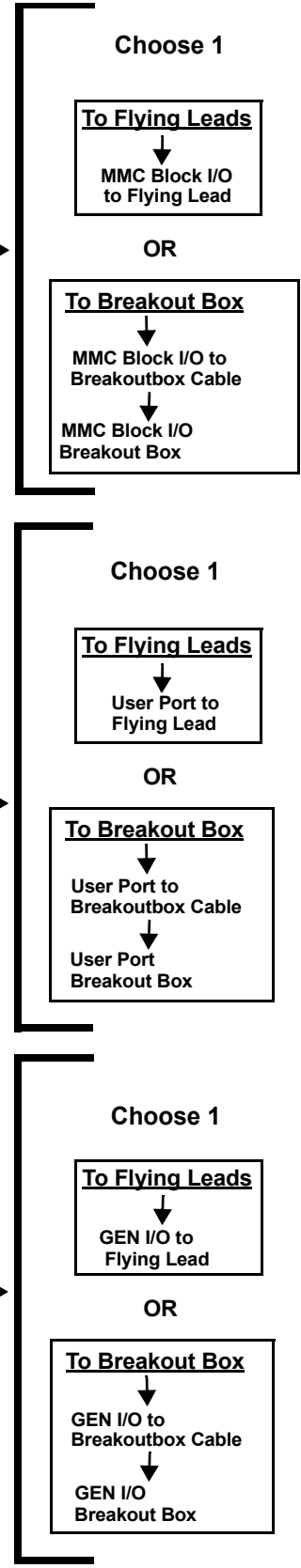

MMC Machine and Motion Controls - Part Numbers

MMC Machine & Motion Controls	
Description	Part Number
MMC-A2 2 Axis Analog MMC	M.1017.3772
MMC-A2 Plus (expandable)	M.1302.7095
MMC-A4 4 Axis Analog MMC	M.1017.3774
MMC-A4 Plus (expandable)	M.1302.7096
MMC-S8 8 Axis SERCOS MMC	M.1017.3770

MMC Machine and Motion Controls Connectors - Part Numbers

MMC Axis Connector Cables and Breakout Box (only for MMC Servo Control Axis Ports A1, A2, A3, A4)		
MMC Smart Drive		
Description	Length	Part Number
MMC Axis A 'n' to Drive IO Connector	0.5 meters	M.1302.5990
	1 meter	M.1302.5991
	1.5 meters	M.1302.5992
	3 meters	M.1302.5993
Flying Lead		
Description	Length	Part Number
MMC Axis A'n' to Flying Lead Cable	10'	M.1016.2519
Breakout Box		
Description	Length	Part Number
MMC Axis A'n' to Breakout Box Cable	1'	M.1016.2535
	2'	M.1016.2536
	3'	M.1016.2537
MMC Connector Breakout Box	N/A	M.1016.2529

MMC Auxiliary I/O Connector Cables and Breakout Box		
Flying Lead		
Description	Length	Part Number
MMC Aux I/O Connector to Flying Lead	10'	M.1016.2566
Breakout Box		
Description	Length	Part Number
MMC Gen/Aux I/O Connector to Breakout Box Cable	1'	M.1016.2539
	2'	M.1016.2540
	3'	M.1016.2541
MMC Aux I/O Breakout Box	N/A	M.1016.2531
MMC Connector Breakout Box with Encoder Isolation	N/A	M.1016.4236

MMC Block I/O Connector Cables and Breakout Box		
Flying Lead		
Description	Length	Part Number
MMC Block I/O Connector to Flying Lead	10'	M.1016.2568
Breakout Box		
Description	Length	Part Number
MMC Block I/O Connector to Breakout Box Cable	1'	M.1016.2543
	2'	M.1016.2544
	3'	M.1016.2541
MMC Block I/O Breakout Box	N/A	M.1016.2533

MMC User Port I/O Connector Cables and Breakout Box		
Flying Lead		
Description	Length	Part Number
MMC User Port to Flying Lead	10'	M.1016.2565
Breakout Box		
Description	Length	Part Number
MMC User Port to Breakout Box Cable	1'	M.1016.2715
	2'	M.1016.2716
	3'	M.1016.2717
MMC User Port Breakout Box	N/A	M.1016.2530

MMC General I/O Connector Cables and Breakout Box		
Flying Lead		
Description	Length	Part Number
MMC Gen I/O Connector to Flying Lead	10'	M.1016.2567
Breakout Box		
Description	Length	Part Number
MMC Gen/Aux I/O Connector to Breakout Box Cable	1'	M.1016.2539
	2'	M.1016.2540
	3'	M.1016.2541
MMC Gen I/O Breakout Box	N/A	M.1016.2532

MMC Mounting Instructions

Mount the unit to your cabinet using the mounting slots on the MMC. The MMC unit may be mounted vertically or horizontally. The recommended size of mounting hardware is #10 bolts with #10 star washers (to ensure proper ground connection). MMC-A2 and MMC-A4 controls can have up to two option modules. MMC-A2 Plus and MMC-A4 Plus controls can have up to four option modules.

MMC Mounting Dimensions

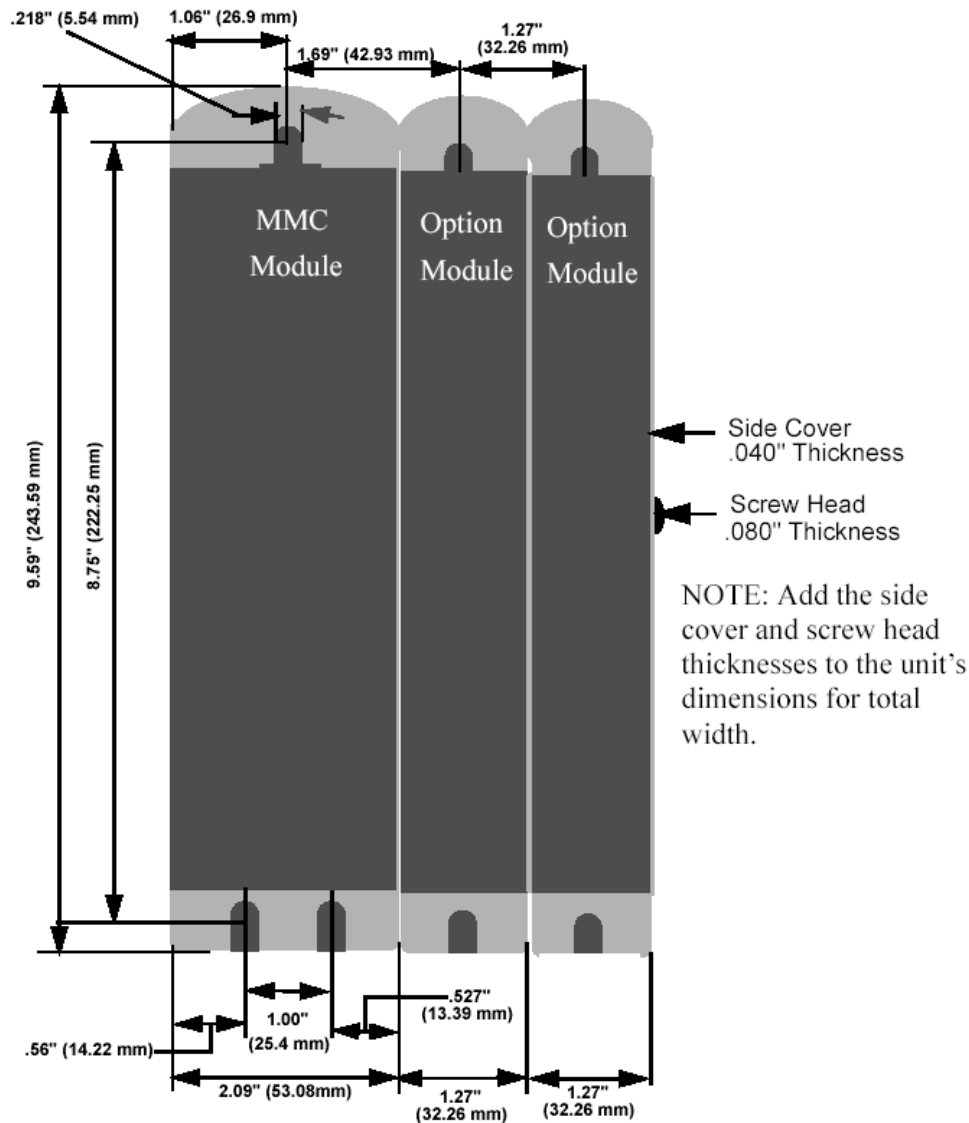

MMC Accessories

MMC Breakout Box

There are five MMC Breakout Boxes available that simplify wire termination to the MMC Controls.

Breakout Box Description	Part Number
MMC Axis Connector Breakout Box	M.1016.2529
MMC Auxiliary I/O Breakout Box	M.1016.2531
MMC User Port Breakout Box	M.1016.2530
MMC General I/O Breakout Box	M.1016.2532
MMC Block I/O Breakout Box	M.1016.2533

Breakout Box Dimensions

Dimensions - 44-Pin Breakout Box for AUX I/O and GEN I/O MMC Connectors

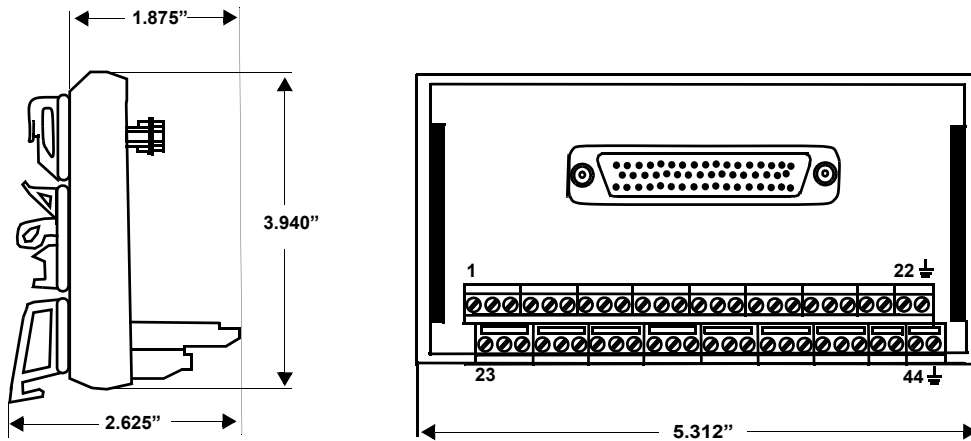

Dimensions - 15-Pin Breakout Box for Axis and User Port MMC Connectors

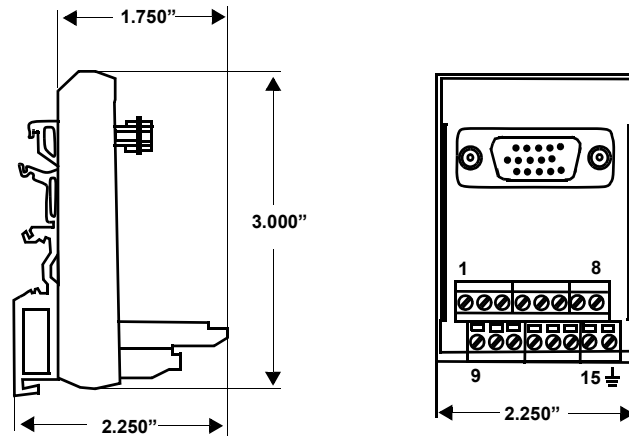

Dimensions - 9-Pin Breakout Box for Block I/O MMC Connector

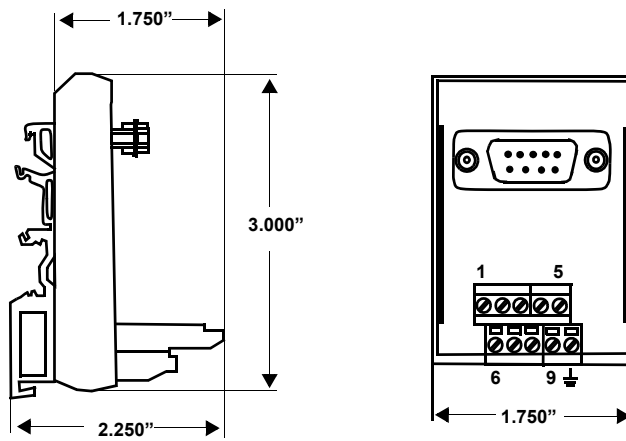

MMC Breakout Box Cables

Breakout Box Cable Description	Length	Part Number
MMC Axis A'n' to Breakout Box Cable	1'	M.1016.2535
	2'	M.1016.2536
	3'	M.1016.2537
MMC User Port to Breakout Box Cable	1'	M.1016.2715
	2'	M.1016.2716
	3'	M.1016.2717
MMC Gen/Aux I/O Connector to Breakout Box Cable	1'	M.1016.2539
	2'	M.1016.2540
	3'	M.1016.2541
MMC Block I/O Connector to Breakout Box Cable	1'	M.1016.2543
	2'	M.1016.2544
	3'	M.1016.2545

MMC Flying Lead Cables

Flying Lead Cable Description	Length	Part Number
Flying Lead Cable to MMC Axis A'n'	10'	M.1016.2519
Flying Lead Cable to MMC User Port	10'	M.1016.2565
Flying Lead Cable to MMC General I/O Connector	10'	M.1016.2567
Flying Lead Cable to MMC Auxiliary I/O Connector	10'	M.1016.2566
Flying Lead Cable to MMC Block I/O Connector	10'	M.1016.2568

MMC Specification Table

General												
Characteristic		MMC Specifications										
								Number of servo axes available at six update rates*				
Model	Part Number	Speed	App Mem	RAM Mem	User Mem	8 ms	4 ms	2 ms	1 ms	.5 ms	.25 ms	
MMC-A2	M.1017.3772	Std.	256K	128K	64K	2	2	2	2	2	1	
MMC-A2 Plus	M.1302.7095	X3	256K	128K	64K	18	18	16	8	3	1	
MMC-A4	M.1017.3774	Std.	256K	128K	64K	4	4	4	4	2	1	
MMC-A4 Plus	M.1302.7096	X3	256K	128K	64K	20	20	16	8	3	1	
MMC-S8	M.1017.3770	Std.	256K	128K	64k	8	8	8	4	n/a	n/a	

*The number of axes that can be run at a particular update rate depends on the use of available memory and CPU execution time. Examples of software that are heavy users of these resources include servo tasks, S-curve, RATIO_RL, M_LINCIR, M_SCRVLC, PLS, and CAM_OUT. Consult Sheffield Automation for assistance if you want to exceed the number of axes in this chart.

CPU	32 bit RISC processor with numeric coprocessor
Battery	3V Coin Cell, BR2032 lithium battery
<p>CAUTION for Lithium Batteries</p> <p>Danger of explosion if battery is incorrectly replaced. Replace only with the same or equivalent type recommended by the manufacturer. Dispose of used batteries according to the manufacturer's instructions.</p>	
Flash Disk	2 Megabytes
Memory	1 Megabyte max.
PiCPro Port (to workstation)	RS232 serial port, secured protocol Software selectable baud rate to 57.6K
User Port (to serial interface device)	RS232/RS485 serial port Supports RTS/CTS hardware handshaking Software selectable baud rate to 19.2K
Input voltage	20 VDC to 30 VDC
Input power	250 mA plus I/O power
Time-of-day clock	Access via PiCPro 10.2 and above or your application program
Clock tolerance	At 25°C (77°F), ±1 second per day Over temperature, voltage and aging variation, 2-1/2 seconds per day

MMC Specification Table

Operating temperature range	5°C to 55°C (41°F to 131°F)
Storage temperature range	-40°C to 85°C (-40°F to 185°F)
Humidity	5 to 95%, non-condensing
CE Marked	<p>Conforms to Directives 73/23/EEC, 89/336/EEC, 92/31/EEC, 93/68/EEC by conforming to the following standards:</p> <p>EN 50081-2:1993EMC Generic Industrial Emissions</p> <p>EN 50082-2:1995EMC Generic Industrial Immunity</p> <p>EN 61131-2:1994/A11:1996 Low voltage directive requirements for programmable controllers</p> <p>Operates with emissions below EN55011/ CISPR 11 Class A limits</p> <p>Immune to:</p> <ul style="list-style-type: none"> •Electrostatic discharge (4K V contact mode, 8K V air discharge) per EN61000-4-2 •RF electromagnetic fields per EN61000-4-3, ENV 50141, and ENV50204 •Electrical fast transients per EN61000-4-4 •Magnetic fields per EN61000-4-8 <p>Refer to the EMC Guidelines for more information.</p>
UL and C/UL Listed	E126417
Physical size	2.25" wide x 9.6" high x 5.3" deep 57.15 mm x 243.84 mm x 134.62 mm
Analog Output	
Output channels	2 or 4
Resolution	16 bits
Output voltage range	±10 VDC
Maximum output current (1K ³ / ₄ load)	±10 mA
Power on output voltage	0 V ±100 mV
Scan loss output voltage	0V ±100 mV
Accuracy	±0.375% of FSR Drift ± 50ppm/°C
Update rate	68 µsec

Analog Input	
Input channel	1
Resolution	12 bits
Input voltage range	±10 V
Accuracy	±0.2% of FSR
Sample rate	100 µsec
Common mode filter	3 dB @ 10 K Hz
Differential mode filter	3 dB @ 475 Hz
Encoder Input	
Input channels	3 or 5
Input receiver type	2632 differential RS422 type receiver
Encoder signals	Differential quadrature
Input threshold	±200 mV
Input termination	120 ³ / ₄
Maximum input voltage	5 V
Maximum A or B input frequency	250 K Hz (1 M feedback unit count rate)
Fast input voltage	Nominal 24 VDC, maximum 30 VDC
Guaranteed on voltage	15 VDC
Guaranteed off voltage	5 VDC
Turn on/off time	1 ms

General, Auxiliary and Axis DC Inputs	
Configuration	There are 16 general inputs. The auxiliary inputs are divided into two groups of six inputs. Each group can be configured for sourcing or sinking. The axis inputs have one input per axis. Each input can be configured for sourcing or sinking. Operates with IEC Type 1 inputs (per IEC 1131=2).
Input voltage	Nominal 24 VDC, maximum 30 VDC
Guaranteed on voltage	15 VDC
Guaranteed off voltage	5 VDC
Turn on/off time	1 ms
General DC Outputs	
Number of outputs	16 outputs
Input voltage	Nominal 24 VDC, 30 VDC maximum
Configuration	Two groups of eight solid-state switches.
Protection of logic circuits	Optical isolation between the logic and field side, transient suppression on the 24V external supply
Maximum current	.25 A per output
Voltage range	24 VDC nominal, 5 to 30 VDC
Switch characteristics	Solid-state switches
Time delay on for resistive loads	50 µsec max
Time delay off for resistive loads	50 µsec max
Leakage current in off state	0.5 mA max
Switch voltage, maximum ON	1 VDC max
Short circuit protection for each group	15 A (max) pulses for about 130 µsec every 100 msec until short is removed
Scan loss response	Outputs turn off

Axis DC Outputs	
Number of outputs	2 outputs per axis
Configuration	Each set of axis outputs can be configured as sourcing or sinking.
Maximum current	100 mA per output
Voltage range	24 VDC nominal, 5 to 30 VDC range
Scan loss response	Outputs turn off

Available I/O			
I/O	MMC-A2 2 1/2 Axis	MMC-A4 4 1/2 Axis	MMC-S8 8-Axis SERCOS
Analog Inputs	1	1	0
Analog Outputs	2	4	0
Encoder Inputs	3	5	0
Axis DC Inputs	2	4	0
Axis DC Outputs	4	8	0
Axis Fast DC Inputs	3	5	0
AUX I/O Port DC Inputs	6	12	16
General I/O Port DC Inputs	16	16	16
General I/O Port DC Inputs	16	16	16

MMC Axis I/O Option Module

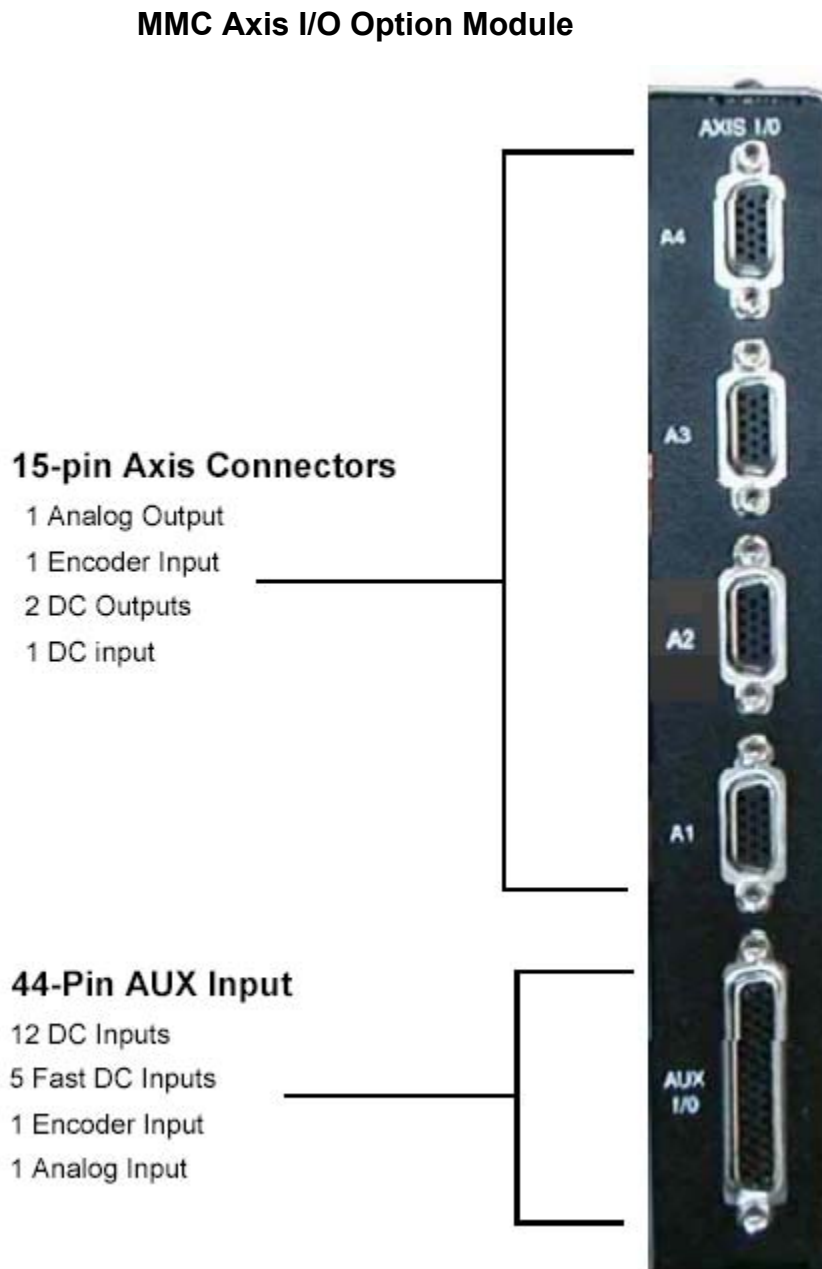

The Axis I/O Option Module is used with the MMC-A2 Plus or MMC-A4 Plus control to provide control of up to four additional servo amplifiers. PiCPro for Windows Professional Edition is required to program MMC Plus applications using the axis I/O Option Module.

Axis A1 to A4 Connectors. On the Axis I/O Option Module, each axis connector (labeled A1 to A4) provides a connection to a servo amplifier. Each axis connector contains a differential encoder input, a +/- 10V analog output, two 24VDC discrete outputs

for drive enable and drive reset, and one 24VDC discrete input for the drive ready or drive OK signal. Only one cable is required to interface an MMC to MMC Smart Drive amplifier. Encoder inputs and analog outputs not used for the closed loop servos can be used for variable frequency drives or additional master axes.

Aux I/O. On the Axis I/O Option Module, the Aux I/O connector contains the fast inputs for each axis (including the half axis encoder input) for registration and hardware interrupt capability. It also contains the differential encoder input for the half axis, one analog input, and three 24VDC discrete inputs for each closed loop axis. Typically, these inputs would be used for plus and minus end of travel limits and for the reference switch. However, they can be used as general purpose inputs if they are not being used for end-of-travel and reference switch. Refer to the MMC Specification Table Analog Output, Encoder Input, and General, Auxiliary and Axis DC Inputs specifications for detailed information.

AVAILABLE I/O	
I/O	MMC-AIO
Analog Inputs	1
Analog Outputs	4
Encoder Inputs	5
Axis DC Inputs	4
Axis DC Outputs	8
Axis Fast DC Inputs	5
AUX I/O Port DC Inputs	12

MMC Ethernet - TCP/IP Module

The ETHERNET - TCP/IP module provides the MMC with Ethernet access and Internet connectivity. A 10Base T connection is provided following the IEEE 802.3 specification. The data transfer rate is 10 Mbps. Applications can range from connecting several MMCs, connecting groups of MMCs and PCs, or connecting to a system that includes Internet access. At the end of this document is a partial list of Internet links to useful information about Ethernet and TCP/IP networking.

The Remote Programmer Access switch will allow you to enable/disable PiCPro for Windows running over Ethernet. The DIAG LED goes on briefly while the diagnostic tests are running shortly after power is applied.

MMC Ethernet - TCP/IP Module

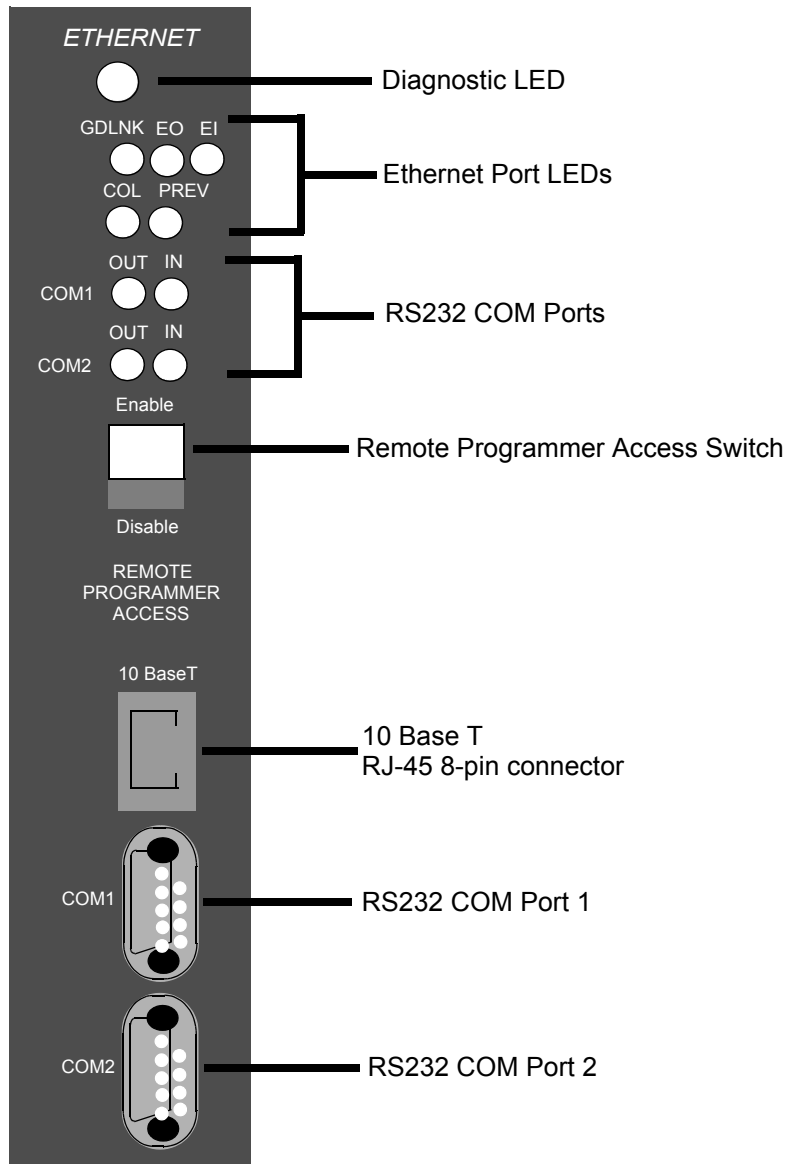

Specification Table

Characteristics	Ethernet - TCP/IP Module Specifications
Function	Provides Ethernet access and Internet connectivity
Part Number	M.1017.3888
RS232 Port 1	Com Port 1 modem (future)
RS232 Port 2	Com Port 2 (for firmware and configuration loading)
10Base T	RJ-45 8-pin connector Maximum twisted pair length is 100 m (328 ft.).
24 VDC Power from the MMC	200 mA
Operating temperature range	7° C to 55° C (45° F to 131° F)
Storage temperature range	-40° C to 85° C (-40° F to 185° F)
Humidity	5 to 95%, non-condensing
CE Marked	<p>Conforms to Directives 73/23/EEC, 89/336/EEC, 92/31/EEC, 93/68/EEC by conforming to the following standards:</p> <p>EN 50081-2:1993 EMC Generic Industrial Emissions EN 50082-2:1995 EMC Generic Industrial Immunity EN 61131-2:1994/A11:1996 Low voltage directive requirements for programmable controllers</p> <p>Operates with emissions below EN55011/ CISPR 11 Class A limits</p> <p>Immune to:</p> <ul style="list-style-type: none"> • Electrostatic discharge (4K V contact mode, 8K V air discharge) per EN61000-4-2 • RF electromagnetic fields per EN61000-4-3, ENV 50141, and ENV50204 • Electrical fast transients per EN61000-4-4 • Magnetic fields per EN61000-4-8 <p>Refer to the EMC Guidelines for more information.</p>
UL and C/UL Listed	E126417
Physical size	1.3" wide x 9.6" high x 5.3" deep 33 mm x 244 mm x 135 mm
Vibration (per IEC 68-2-6)	10-57 Hz (constant amplitude .15 mm) 57 - 2000 Hz (acceleration 2 g)
Shock (per IEC 68-2-27)	Four shocks per axis (15g/11 msec)

MMC DeviceNet Module

Introduction

The MMC DeviceNet scanner module is an interface between the MMC and a DeviceNet network. The module contains an on-board processor, a DeviceNet compliant interface, and firmware that makes it act as the master to all other nodes on the network.

Prior to initial operation, a file is generated with specific configuration software in an external PC. This file must be downloaded via the RS232 configuration port to the DeviceNet module prior to initial operation. Two indicator LEDs (IN/OUT) are connected to this configuration port.

Directly above the DeviceNet port are two LEDs that provide operation information: Network Status and DeviceNet Scanner Status.

The DIAG LED goes on briefly while the diagnostic tests are running.

MMC DeviceNet Module

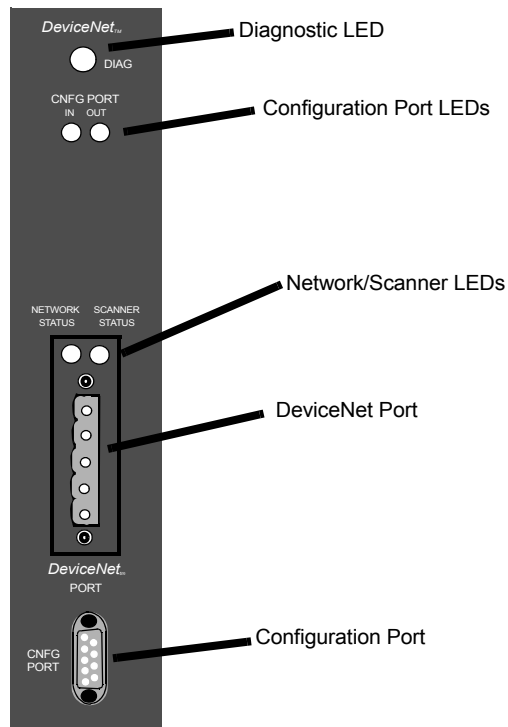

Connections

DeviceNet connections are illustrated in Figure B1-. Up to 63 DeviceNet Nodes may be attached to the DeviceNet scanner module.

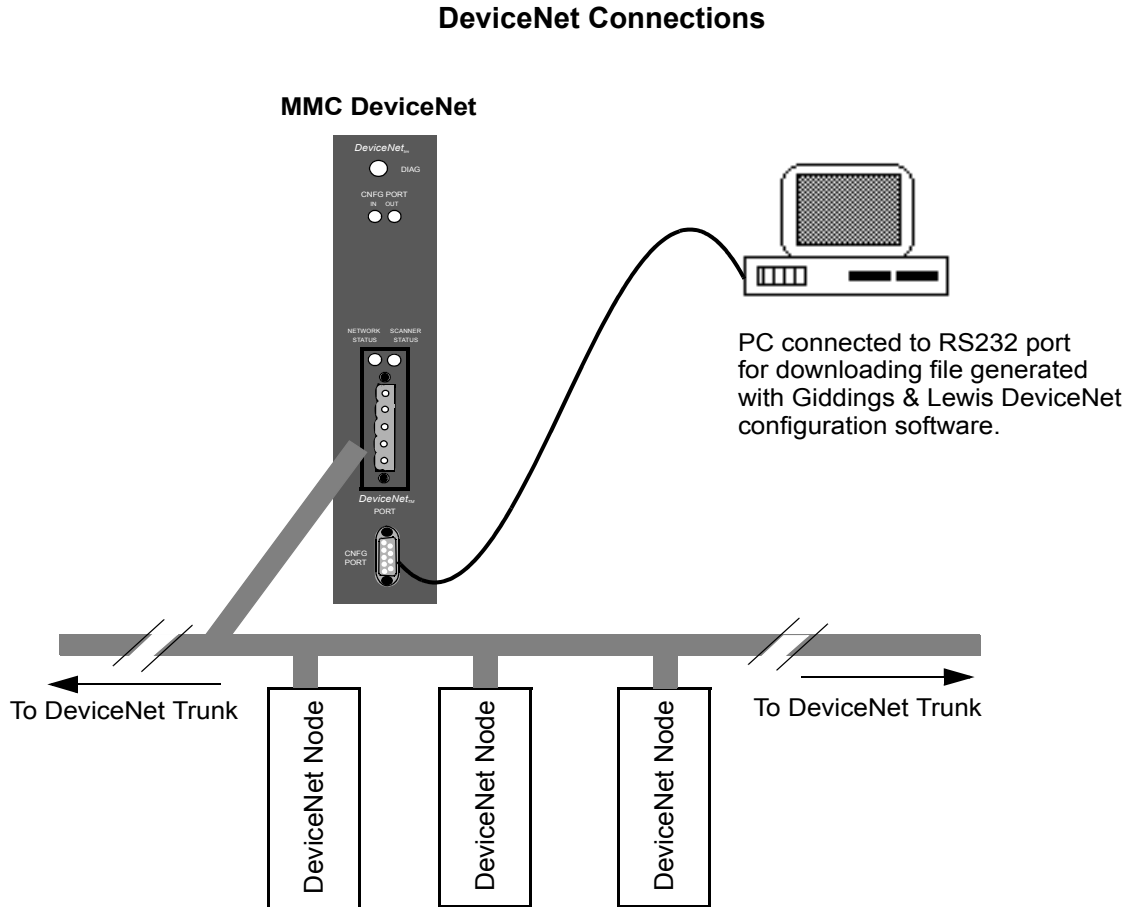

The DeviceNet Port

The DeviceNet port is on the front of the module near the center as shown in Figure B1-. The pinout for the DeviceNet port is shown below:

Pin #	Signal Name	Standard Wire Colors
1	V-	black
2	CAN_L	blue
3	Shield (drain)	bare
4	CAN_H	white
5	V+	red

In your network layout, follow DeviceNet specifications. Only use DeviceNet compliant cable, such as Belden 3084A thin wire and Belden 3082A thick wire.

The Configuration (RS232) Port

There is an RS232 port on the lower front of the module as shown in Figure B1-. This is used to connect to a PC in order to download a file representing your DeviceNet network.

Pin #	Signal Name	In/Out
2	Receive Data	In
3	Transmit Data	Out
5	Ground	In/Out

LEDs

The two configuration port LEDs and the two DeviceNet port LEDs are described below.

	LED	Color	State	Definition	
DeviceNet Port	Network status	None	OFF	Off-line	
		Green	ON	On-line and connected to at least one node	
			Flashing	On-line but connection nodes not established	
		Red	ON	Unrecoverable Fault (duplicate MAC ID check failed, critical bus fault etc.)	
			Flashing	I/O connections in timed-out state or other Recoverable Fault	
	Scanner status	Green	OFF		No power or else reset asserted
			ON		Scanner OK and active
			Flashing		Scanner OK but not active
		Red	ON		Hardware or software error
			Flashing		Recoverable configuration error (invalid data downloaded)
		Orange	ON		Configuration (download) mode
	Configuration Port	IN	Red	Flickering	Data is being passed to the module
				OFF	No data to the module
OUT		Red	Flickering	Data is being passed from the module	
			OFF	No data from the module	

Theory of Operation

The DeviceNet scanner module provides a memory image of the nodes (slaves) connected to a DeviceNet network. It is this memory image that is controlled by your LDO created in PiCPro. The module's on-board processor continually transfers data between this memory image and the actual DeviceNet nodes.

Communication between the DeviceNet module and the nodes can be set at 125 Kbaud, 250 Kbaud, or 500 Kbaud. The baud rate, the relationship between the memory image and specific data in each node, and other parameters are established with configuration software run in an external PC.

This configuration software generates two files. One file is downloaded to the DeviceNet module through its RS232 serial port. The other file is used by PiCPro to establish the relationship between the memory image and the declared variables in the LDO. To ensure that a given location in the memory image is connected to a variable in the LDO and to the corresponding data in the DeviceNet node, the same tag name or label must be used.

For example, when running the configuration software, PROX_SW1 could be used as the name for the boolean bit representing a DeviceNet proximity switch's logic state. The name PROX_SW1 must also be used for the corresponding variable in your LDO.

NOTE

The G&L DeviceNet configuration software (G&L Part No. M.1300.7217) is required to configure the DeviceNet scanner (within the DeviceNet module) for the devices on the associated network.

NOTE

Additional information about DeviceNet can be obtained from www.odva.org.

Specifications

Characteristics	DeviceNet Module Specifications
Function	Interfaces to a DeviceNet network with up to 63 other nodes
Part number	M.1017.3889 (old # 503-26684-00)
DeviceNet Port	Phoenix style 5-pin male connector
Configuration Port	RS232 interface
24 V DC Power from the MMC	100 mA
Operating temperature range	7° C to 55° C (45° F to 131° F)
Storage temperature range	-40° C to 85° C (-40° F to 185° F)
Humidity	5 to 95%, non-condensing
CE Marked	<p>Conforms to Directives 73/23/EEC, 89/336/EEC, 92/31/EEC, 93/68/EEC by conforming to the following standards:</p> <p>EN 50081-2:1993 EMC Generic Industrial Emissions EN 50082-2:1995 EMC Generic Industrial Immunity EN 61131-2:1994/A11:1996 Low voltage directive requirements for programmable controllers</p> <p>Operates with emissions below EN55011/ CISPR 11 Class A limits</p> <p>Immune to:</p> <ul style="list-style-type: none"> • Electrostatic discharge (4K V contact mode, 8K V air discharge) per EN61000-4-2 • RF electromagnetic fields per EN61000-4-3, ENV 50141, and ENV50204 • Electrical fast transients per EN61000-4-4 • Magnetic fields per EN61000-4-8 <p>Refer to the EMC Guidelines for more information.</p>
UL and C/UL Listed	File No. E126417 NRAQ Programmable Controllers
Physical size	1.3" wide x 9.6" high x 5.3" deep 33 mm x 244 mm x 135 mm
Vibration (per IEC 68-2-6)	10-57 Hz (constant amplitude .15 mm) 57 - 2000 Hz (acceleration 2 g)
Shock (per IEC 68-2-27)	Four shocks per axis (15g/11 msec)

MMC Profibus Module

Introduction

The MMC Profibus scanner module is an interface between the MMC and a Profibus network. The module contains an on-board processor, a Profibus compliant interface, and firmware that makes it act as the master to all other nodes on the network.

Prior to initial operation, a file is generated with specific configuration software in an external PC. This file must be downloaded via the RS232 configuration port to the Profibus module prior to initial operation. Two indicator LEDs (IN/OUT) are connected to this configuration port.

Directly above the Profibus port are two LEDs that provide operation information: Network Status and Profibus Scanner Status.

The DIAG LED goes on briefly while the diagnostic tests are running.

MMC Profibus Module

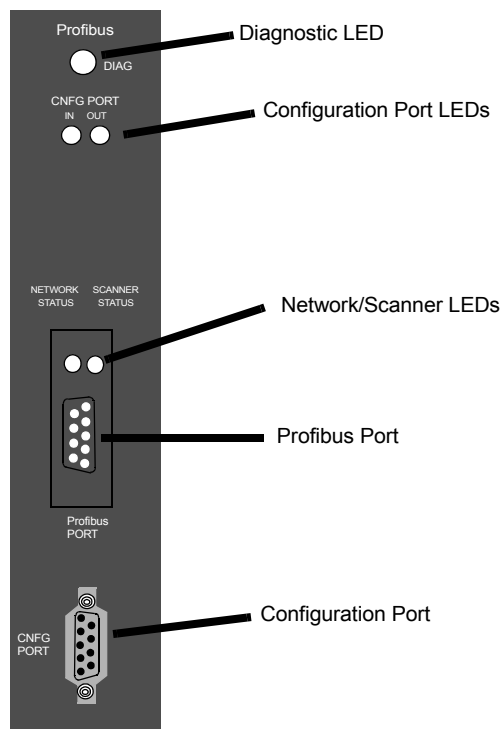

Connections

Profibus connections are illustrated below. Up to 31 Profibus nodes, without repeaters, may be attached to the Profibus scanner. Up to 125 other Profibus Nodes, using repeaters, may be attached to the Profibus scanner module.

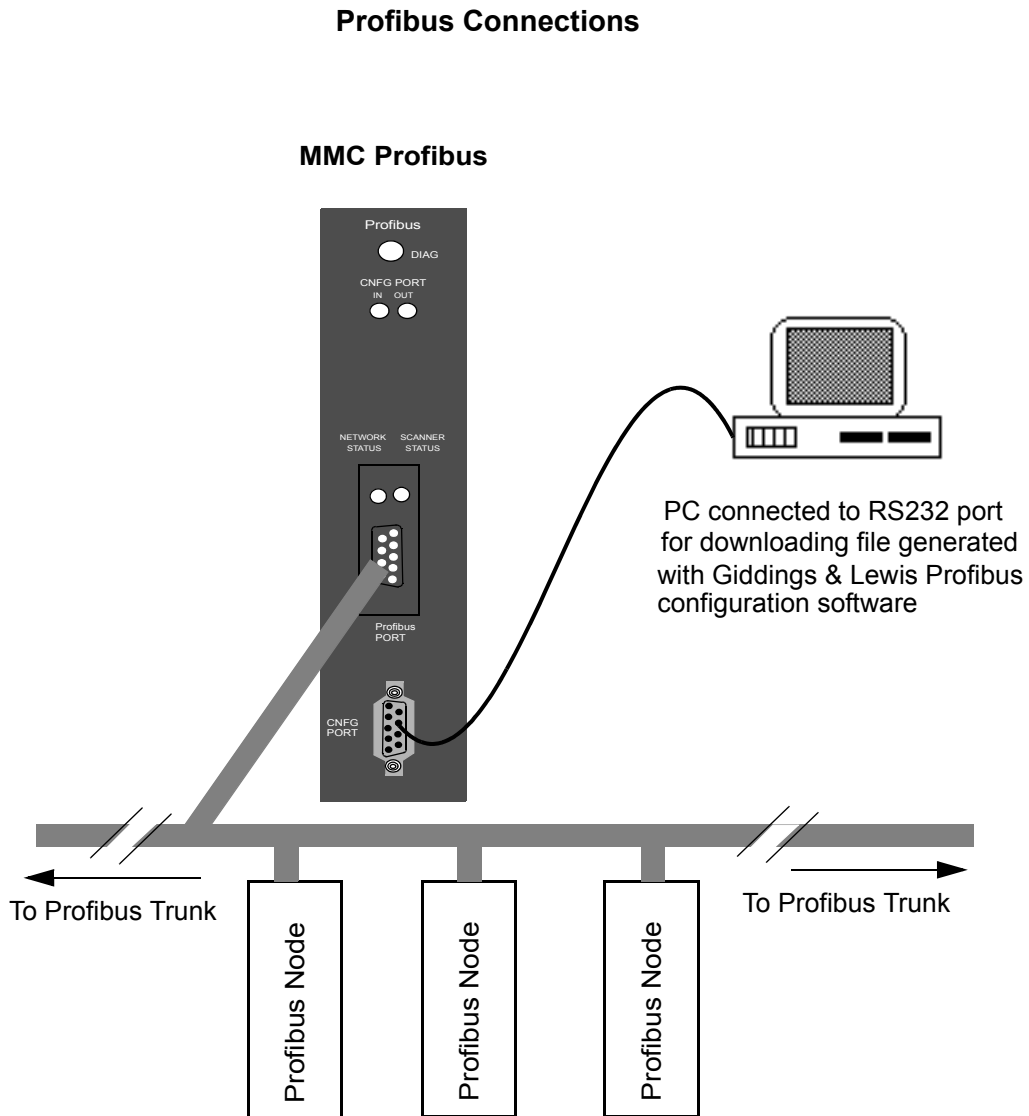

The Profibus Port

The Profibus port is on the front and center of the module. The pinout for the Profibus port is shown below:

Pin #	Signal Name	Note:
1	Chassis ground	It is strongly recommended that you use Profibus Sub-D connectors with switchable (ON/OFF) termination, such as Siemens 6ES7 972-0BA11-0XA0 or 6ES7 972-0BB11-0XA0. Only use Profibus type A cable, such as Belden 3079A or Siemens 6XV1 830-0AH10.
2	reserved	
3	data +	
4	Tx enable	
5	Isolated ground	
6	voltage plus	
7	reserved	
8	data -	
9	reserved	

The Configuration (RS232) Port

There is an RS232 port on the lower front of the module. This is used to connect to a PC in order to download a file representing your Profibus network.

Pin #	Signal Name	In/Out
2	Receive Data	In
3	Transmit Data	Out
5	Ground	In/Out

LEDs

The two configuration port LEDs and the two Profibus port LEDs are described below.

	LED	Color	State	Definition
Profibus Port	Network status	Green	OFF	Off-line
			ON	On-line and connected to at least one node
		Red	ON	On-line but bus error present (baud rate or wiring problem)
	Scanner status	Green	OFF	No power or else reset asserted, interface closed
			ON	Scanner OK and active (interface open)
		Red	ON	Interface open, at least one slave faulted
		Orange	ON	Configuration (download) mode
	Configuration Port	IN	Red	Flickering
OFF				No data to the module
OUT		Red	Flickering	Data is being passed from the module
			OFF	No data from the module

Theory of Operation

The Profibus scanner module provides a memory image of the nodes (slaves) connected to a Profibus network. It is this memory image that is controlled by your LDO created in PiCPro. The module's on-board processor continually transfers data between this memory image and the actual Profibus nodes.

Communication between the Profibus module and the nodes can be set between 9600 baud (1200m max.) and 12M baud (100m max.). The baud rate, the relationship between the memory image and specific data in each node, and other parameters are established with configuration software run in an external PC.

This configuration software generates two files. One file is downloaded to the Profibus module through its RS232 serial port. The other file is used by PiCPro to establish the relationship between the memory image and the declared variables in the LDO. To ensure that a given location in the memory image is connected to a variable in the LDO and to the corresponding data in the Profibus node, the same tag name or label must be used.

For example, when running the configuration software, PROX_SW1 could be used as the name for a boolean bit of a Profibus Block I/O. It would correspond to the wiring location of a proximity switch. The name PROX_SW1 must also be used for the corresponding variable in your LDO.

NOTE

The G&L Profibus configuration software (G&L Part No. M.1300.7218) is required to configure the Profibus scanner (within the Profibus module) for the devices on the associated network.

NOTE

Additional information about Profibus can be obtained at www.profibus.com

Specifications

Characteristics	Profibus Module Specifications
Function	Interfaces (acts as DP Master - Class 1), to a Profibus network with up to 125 other nodes, using repeaters
Part number	M.1300.7167
Profibus Port	9-pin female D-sub connector
Configuration Port	RS232 interface
24 V DC Power from the MMC	100 mA
Operating temperature range	7° C to 55° C (45° F to 131° F)
Storage temperature range	-40° C to 85° C (-40° F to 185° F)
Humidity	5 to 95%, non-condensing
CE Marked	<p>Conforms to Directives 73/23/EEC, 89/336/EEC, 92/31/EEC, 93/68/EEC by conforming to the following standards:</p> <p>EN 50081-2:1993 EMC Generic Industrial Emissions</p> <p>EN 50082-2:1995 EMC Generic Industrial Immunity</p> <p>EN 61131-2:1994/A11:1996 Low voltage directive requirements for programmable controllers</p> <p>Operates with emissions below EN55011/ CISPR 11 Class A limits</p> <p>Immune to:</p> <ul style="list-style-type: none"> • Electrostatic discharge (4K V contact mode, 8K V air discharge) per EN61000-4-2 • RF electromagnetic fields per EN61000-4-3, ENV 50141, and ENV50204 • Electrical fast transients per EN61000-4-4 • Magnetic fields per EN61000-4-8 <p>Refer to the EMC Guidelines for more information.</p>
UL and C/UL Listed	File No. E126417 NRAQ Programmable Controllers
Physical size	1.3" wide x 9.6" high x 5.3" deep 33 mm x 244 mm x 135 mm
Vibration (per IEC 68-2-6)	10-57 Hz (constant amplitude .15 mm) 57 - 2000 Hz (acceleration 2 g)
Shock (per IEC 68-2-27)	Four shocks per axis (15g/11 msec)

**MMC CONTROLS, BLOCK I/O AND CIMREX HMI
MOTION SOLUTIONS PRODUCT GUIDE**

MMC for PC

(PC Machine and Motion Control)

MMC for PC (PC Machine and Motion Control)

MMC for PC - SERCOS System

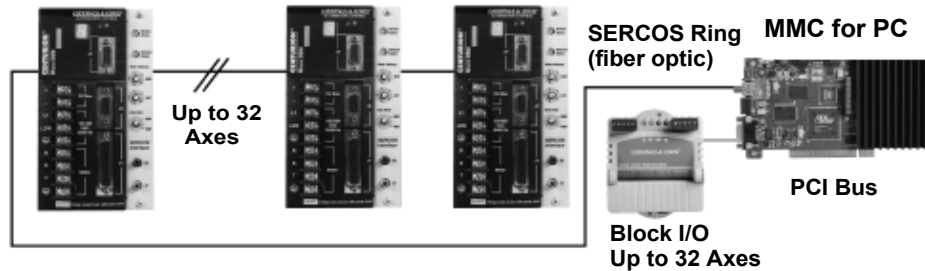

MMC for PC - Analog System

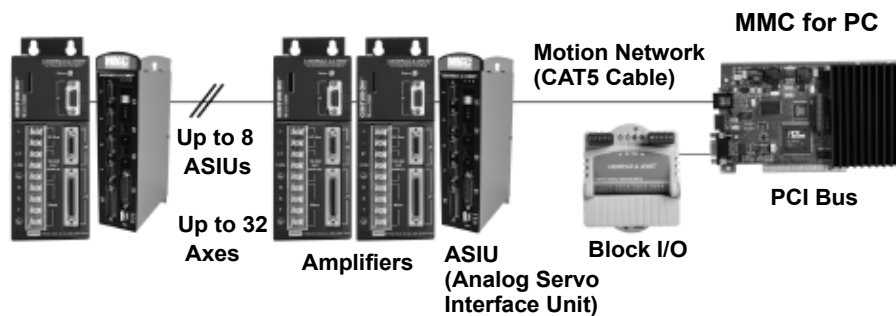

Description. The MMC for PC (PC Machine and Motion Control) is a full-featured total machine control solution for applications requiring up to 32 axes of analog or SERCOS interfaced servo motion control. The MMC for PC is a half-slot PCI card that can be installed in a Windows NT or Windows 2000 or Windows XP Professional Edition personal computer.

Programming. The MMC for PC is programmed using IEC1131 ladder logic, function blocks, and structured text using the Professional Edition of PiCPro for Windows. Programs developed for PiC and stand-alone MMC are 100% compatible with the MMC for PC. The MMC for PC communicates with PiCPro for Windows via the host PC's local Ethernet stack.

Features. Using the MMC for PC, you have the power of PiCPro for Windows at your fingertips. A mature and reliable product, PiCPro for Windows offers animation, variable force and view, cam profiles, linear and circular interpolation, registration, multi-tasking, and UDFBs as standard features. With virtually no re-programming, an application can be loaded into an MMC, PiC or MMC for PC control. This allows you to expand your motion control system from one product to another without wasting valuable engineering time. The MMC for PC status software makes it easy to maintain and troubleshoot your application.

Expanded Features. The MMC for PC hardware allows you to wire an external 24V power supply to the PCI card. In the event power is shut down from the host PC, the MMC for PC will automatically switch over to using this power supply, allowing uninterrupted

control of the machine. The IPSTAT function in PiCPro for Windows indicates to the application program that communication with Windows NT has been lost so appropriate action can be taken.

HMI. Use the PC for your HMI as well as to house the MMC for PC control. Name based data transfer using the Giddings & Lewis OPC Server allows the MMC for PC to communicate with any OPC client on the host PC. Giddings & Lewis CEZAR software is a full-featured, easy-to-use PC HMI software package.

Hardware Connections. The hardware connections made to the MMC for PC PCI processor card are robust and clean. For SERCOS MMC for PC systems, the PCI card is connected to the ring of servo amplifiers with fiber optic cable. For analog MMC for PC systems, the PCI card is connected to up to eight ASIU (analog servo interface units) with CAT-5 Ethernet cable. The connections to servo amplifiers and real time I/O are made to the ASIU and transferred over a high-speed proprietary serial link to the MMC for PC processor board.

I/O. Use the Giddings & Lewis Block I/O, DeviceNet or Profibus. Giddings & Lewis Block I/O is standard on the MMC for PC. A complete family of Block I/O Modules are available, including AC and DC discrete I/O, analog input and output, and stepper output. The MMC for PC processor communicates to Block I/O Modules over a high speed proprietary twisted pair cable. Up to 77 Block I/O Modules can be connected to the processor board. DeviceNet and Profibus are field installable option cards that plug on to the MMC for PC processor board. Both are master scanner cards that communicate with the MMC for PC using shared memory.

MMC for PC SERCOS		
Connection to...	How	Details
Machine I/O	4-wire screw terminal	Up to 77 Giddings & Lewis Block I/O Modules
SERCOS Amplifiers	Fiber-optic	Connect up to 32 SERCOS amplifiers in a ring configuration
Real-time I/O	Fiber-optic	Wire real-time I/O to the SERCOS amplifiers and read/write the information over the SERCOS ring
External Power Supply (optional)	Screw terminal	Allows you to continue to control the machine in the event of a PC power cycle
DeviceNet network	N/A	Connection made on DeviceNet daughter card - width of 2 PCI slots required
Profibus network	N/A	Connection made on Profibus daughter card - width of 2 PCI slots required
Digital Line Shaft	Cat-5 Ethernet Cable	Connection made on DLS daughter card - width of 2 PCI slots required

MMC for PC Analog		
Connection to...	How	Details
Machine I/O	4-wire screw terminal	Up to 77 Giddings & Lewis Block I/O Modules
ASIU (Analog Servo Interface Unit)	CAT-5 Ethernet Cable	Daisy-chain up to 8 ASIU modules to the MMC for PC Analog processor PCI card
+/- 10V Amplifiers	Plug & Play Cables Breakout Boxes Flying Lead Cables	Connection to the amplifiers is made to the ASIU (Analog Servo Interface Unit)
Real-time I/O	Plug & Play Cables Breakout Boxes Flying Lead Cables	Connection to the real-time I/O is made to the ASIU (Analog Servo Interface Unit)
External Power Supply (optional)	Screw terminal	Allows you to continue to control the machine in the event of a PC power cycle
DeviceNet network	N/A	Connection made on DeviceNet daughter card - width of 2 PCI slots required
Profibus network	N/A	Connection made on Profibus daughter card - width of 2 PCI slots required

ASIU Connections:

Axis A1 to A4 Connectors. On the ASIU, each axis connector (labeled A1 to A4) provides a connection to a servo amplifier. Each axis connector contains a differential encoder input, a +/- 10V analog output, two 24VDC discrete outputs for drive enable and drive reset, and one 24VDC discrete input for the drive ready or drive OK signal. Only one cable is required to interface an ASIU to a Centurion DSA or MicroDSA amplifier. Encoder inputs and analog outputs not used for closed loop servos can be used for variable frequency drives or additional master axes.

Aux I/O. On the ASIU, the Aux I/O connector contains the fast inputs for each axis (including the half axis encoder input) for registration and hardware interrupt capability. It also contains the differential encoder input for the half axis, one analog input, and three 24VDC discrete inputs for each closed loop axis. Typically these inputs would be used for plus and minus end of travel limits and for the reference switch. However, they can be used as general purpose inputs if they are not being used for end-of-travel and reference switch.

Gen I/O. The Gen I/O connector contains sixteen general-purpose 24 VDC discrete inputs (sink or source) and sixteen general-purpose 24 VDC discrete outputs (source only). Any of the 16 outputs can be used as CAM or PLS outputs. Two of the inputs (number 1 and number 9) have hardware interrupt capability and can be used to trigger hardware interrupt tasks in the application program.

Cables. There are a number of plug and play cables available to facilitate ASIU wiring. Four types of cables can be used with the A1 to A4 connectors on the ASIU, including a Centurion MicroDSA drive J1 connector, a Centurion DSA drive J1 connector, a flying lead connector or a breakout box connector. For the AUX I/O and GEN I/O connectors, there are two types of cables that can be used: a breakout box connector or a flying lead connector.

MMC for PC

MMC for PC Part Numbers

MMC for PC Package	
Description	Part Number
MMC for PC Analog Package	M.1301.3089
ASIU-2	M.1300.5970
ASIU-4	M.1300.4422
MMC for PC-S8 SERCOS Package	M.1301.4102
MMC for PC-S16 SERCOS Package	M.1301.4103
MMC for PC-S32 SERCOS Package	M.1301.4104
MMC for PC Hardware Manual	M.1300.7621

Note: The MMC for PC packages include the MMC for PC processor board, the Giddings & Lewis OPC Server, the MMC for PC Software Suite and PiCPro for Windows-Monitor Edition.

MMC for PC SERCOS Board

The major components of the SERCOS board are illustrated below and include a standard half size 32 bit 5 volt 33Mhz PCI card, a 32-bit RISC processor running at 128 Mhz (with numeric coprocessor), one SERCOS port that includes a fiber optic input connection and output connection for one SERCOS ring, a +24V Power connector, a 9-Pin Block I/O interface port and lithium coin cell backup battery.

End Bracket Face Plate

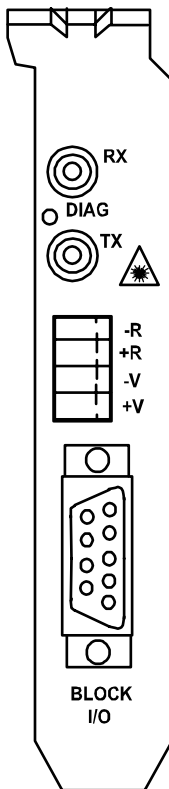

SERCOS Receive Port (RX)
SERCOS Transmit Port (TX)
+24V Power Connector and Lockout Switch Input
Block I/O Interface Port (to Block I/O) 9 Pin D-sub connector

Component View of MMC for PC SERCOS Board

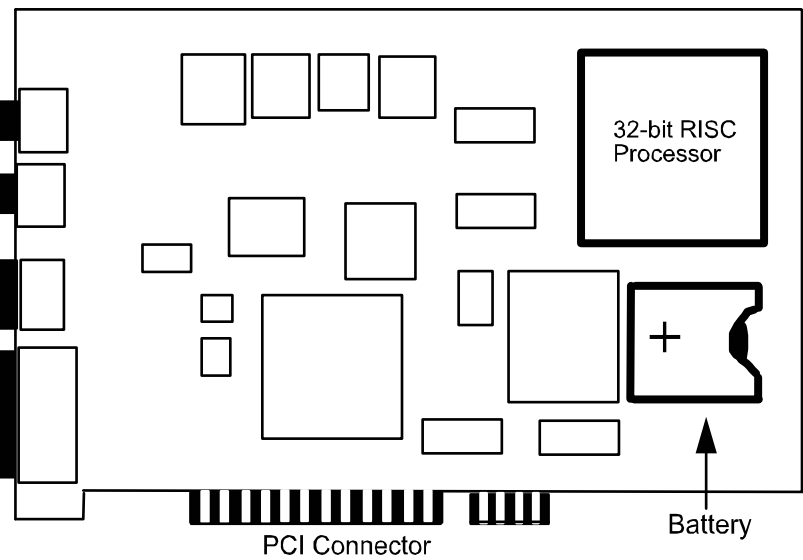

MMC for PC Analog Servo Board

The major components of the Analog Servo board are illustrated below and include a standard half size 32 bit 5 volt 33Mhz PCI card, an 32-bit RISC processor running at 128 Mhz (includes numeric coprocessor), a RJ45 connector for communication with ASIUs, a 9-Pin Block I/O interface port and a a lithium coin cell backup battery

End Bracket Face Plate

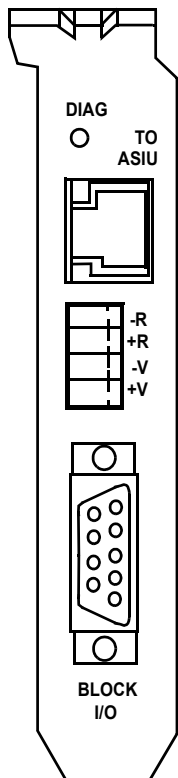

Component View of MMC for PC Analog Servo Board

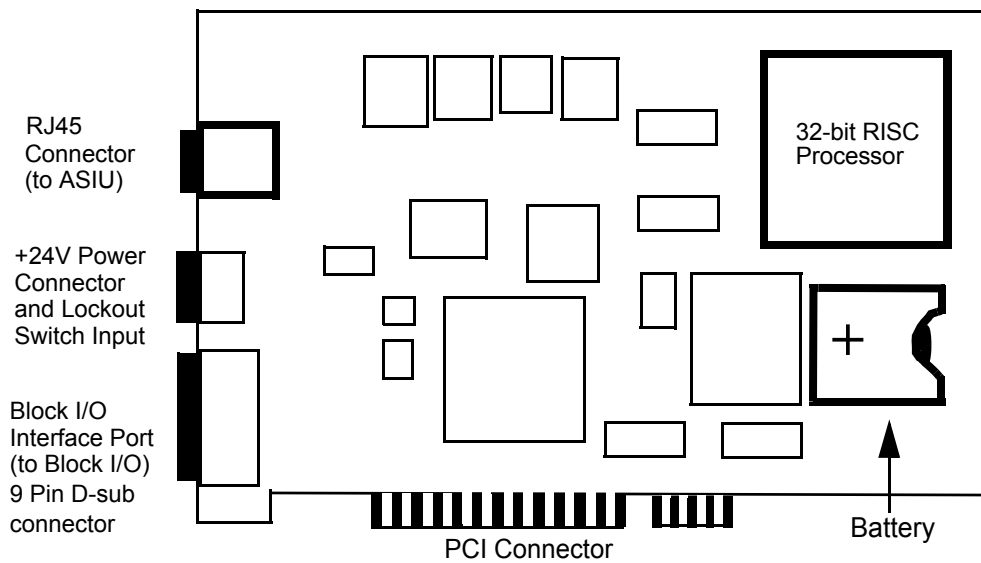

Analog Servo Interface Unit (ASIU)

The Analog Servo Interface Unit (ASIU) provides servo axis interface signals and general purpose I/O for the MMC for PC Analog Board. The ASIU is available in two models, an ASIU-A2 (2 1/2 servo axis unit) and an ASIU-A4 (4 1/2 servo axis unit).

Communication between the ASIU and the MMC for PC Analog Board (mounted in a Personal Computer) is accomplished through the use of a 10Base-T Ethernet interface. The MMC for PC Analog Board can communicate with up to eight ASIUs by connecting the ASIUs together.

Analog Servo Interface Unit (ASIU)

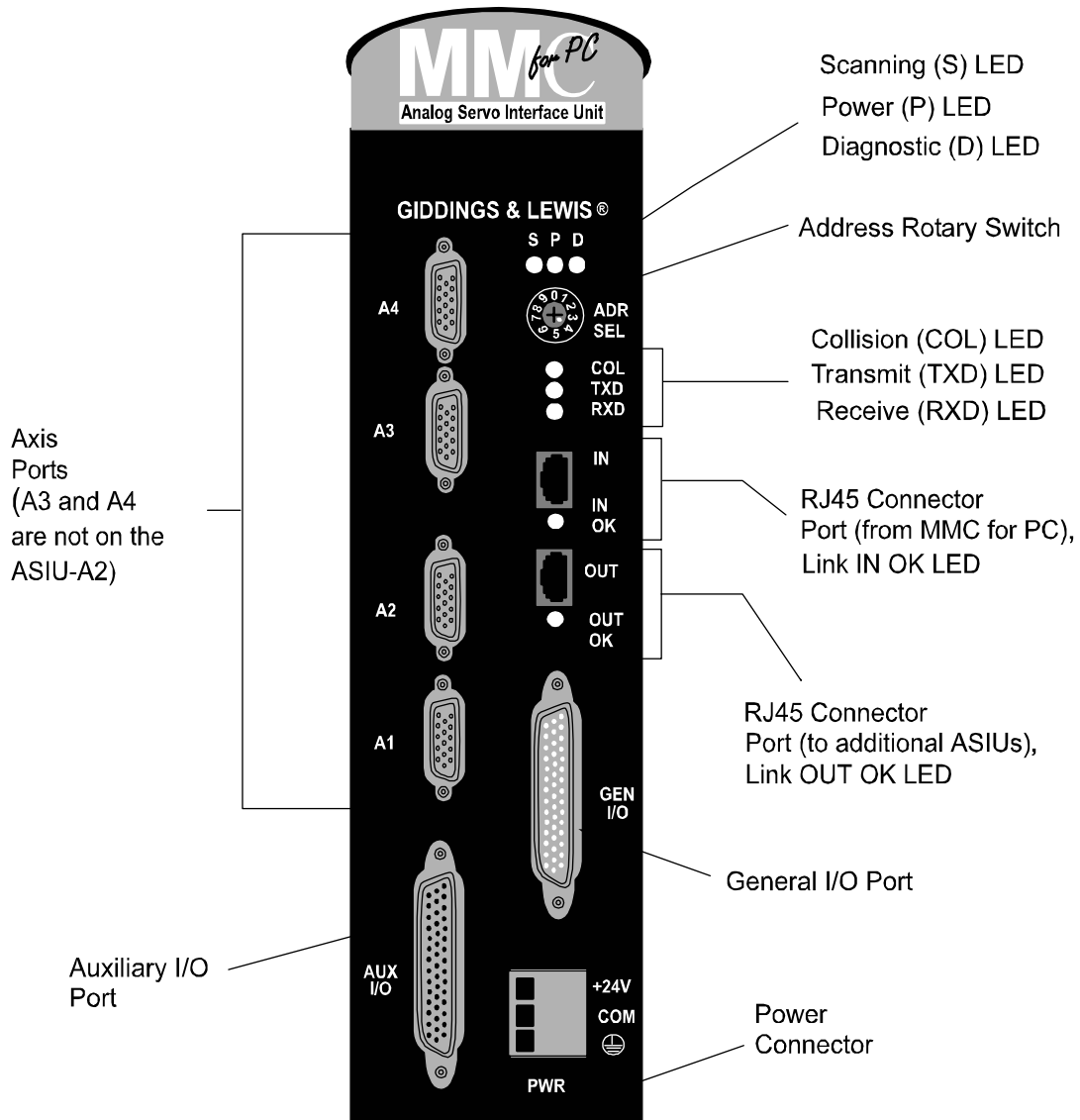

ASIU Major Components

Major external components of the ASIU include:

- Two RJ45 connectors and associated communications circuitry to communicate with the MMC for PC Analog Board and other ASIUs.
- A screwdriver-actuated rotary switch (0 through 9) that allows the user to define the ASIU address. Addresses 1 through 8 define valid ASIUs, and addresses 0 and 9 effectively remove the ASIU from the system (the two RJ45 connectors are still active, but the ASIU will not be seen by the MMC for PC Analog Board).
- A 3-pin power connector to supply 24VDC to the ASIU
- A General I/O port connector for connecting 16 inputs and 16 outputs to user devices.
- An Auxiliary I/O Port for connecting one quadrature incremental encoder, five fast DC inputs, one analog input channel and twelve DC inputs to user devices.
- Four Axis connectors are available on the ASIU-A4 and two are available on the ASIU-A2. Axis connections include one analog output, one encoder input, two DC outputs and one DC input to user devices.
- LED indicators include the following:
 - Scanning (Green) – Indicates CPU is communicating with the ASIU.
 - Power (Green) – Indicates +5V is OK.
 - Diagnostic (Yellow) – On briefly during startup. If it remains ON, ASIU has failed startup diagnostics.
 - Link OK (Green) – Located near each of two RJ45 connectors. These LEDs indicate that the attached RJ45 cable is wired correctly and both ends are powered up.
 - Collision (Red) – Located in the cut-out area of the plastic faceplate. Indicates that 2 or more ASIUs are at the same address.
 - Transmit (Green) – Located in the cut-out area of the plastic faceplate. Indicates that this ASIU is sending a packet of information.
 - Receive (Green) – Located in the cut-out area of the plastic faceplate. Indicates that this ASIU is receiving a packet of information.

ASIU Axis I/O Points

The ASIU provides conventional analog/digital interfacing for two or four drives.

Typical signals needed to interface to an analog drive are provided by the ASIU. The drive command is in the form of an analog voltage ($\pm 10V$). Feedback is accepted from quadrature type encoders with RS422 style differential outputs. Digital I/O (+24 VDC) is used for drive enable, reset, and fault signals.

The ASIU is offered in both 2 1/2 (ASIU-A2) and 4 1/2 (ASIU-A4) axis configurations. An axis is considered to be an analog output with a corresponding encoder input. In each configuration shown below, note that there is an extra encoder input. This is referred to as a half axis.

The following table shows the number of I/O points available on the ASIU for the analog MMC for PC.

Available Axis I/O for ASIU

Available I/O*	ASIU-2	ASIU-4
Analog Inputs	1	1
Analog Outputs	2	4
Encoder Inputs	3	5
Axis DC Inputs	2	4
Axis DC Outputs	4	8
Axis Fast DC Inputs	3	5
AUX I/O Port DC Inputs	6	12
General I/O Port DC Inputs	16	16
General I/O Port DC Outputs	16	16

* With the SERCOS MMC for PC, analog inputs, axis inputs, and feedback signals are transferred over the SERCOS fiber optic link.

ASIU Accesories

Connection Selector Sheet for ASIU (Analog Servo Interface Unit)

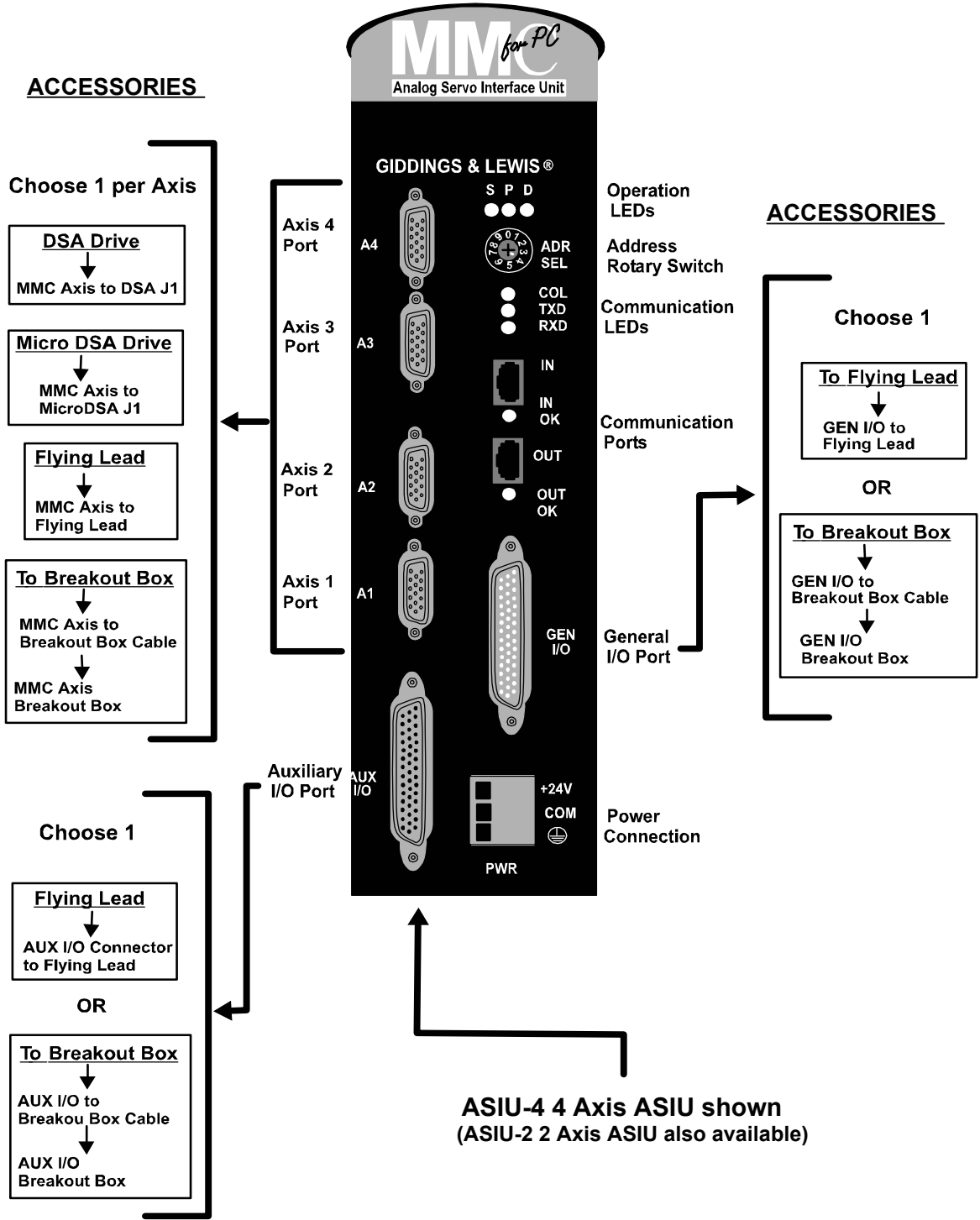

ASIU - Part Numbers

MMC for PC ASIU (Analog Servo Interface Unit)	
Description	Part Number
ASIU-2 2 Axis	M.1300.5970
ASIU-4 4 Axis	M.1300.4422

ASIU Connector Cables and Breakout Boxes - Part Numbers

ASIU Axis Connector Cables and Breakout Box (only for ASIU Servo Control Axis Ports A1, A2, A3, A4)		
DSA Drive		
Description	Length	Part Number
MMC Axis A 'n' to DSA J1 Connector	0.5 Meters	M.1301.5537
	1 Meter	M.1301.5566
	1.5 Meters	M.1301.5569
	3 Meters	M.1301.5592
Flying Lead		
Description	Length	Part Number
MMC Axis A'n' to Flying Lead Cable	10'	M.1016.2519
Breakout Box		
Description	Length	Part Number
MMC Axis A'n' to Breakout Box Cable	1'	M.1016.2535
	2'	M.1016.2536
	3'	M.1016.2537
MMC Connector Breakout Box	N/A	M.1016.2529

ASIU Auxiliary I/O Connector Cables and Breakout Box		
Flying Lead		
Description	Length	Part Number
MMC Aux I/O Connector to Flying Lead	10'	M.1016.2566
Breakout Box		
Description	Length	Part Number
MMC Gen/Aux I/O Connector to Breakout Box Cable	1'	M.1016.2539
	2'	M.1016.2540
	3'	M.1016.2541
MMC Aux I/O Breakout Box	N/A	M.1016.2531
MMC Connector Breakout Box with Encoder Isolation	N/A	M.1016.4236

ASIU General I/O Connector Cables and Breakout Box		
Flying Lead		
Description	Length	Part Number
MMC Gen I/O Connector to Flying Lead	10'	M.1016.2567
Breakout Box		
Description	Length	Part Number
MMC Gen/Aux I/O Connector to Breakout Box Cable	1'	M.1016.2539
	2'	M.1016.2540
	3'	M.1016.2541
MMC Gen I/O Breakout Box	N/A	M.1016.2532

Breakout Box for Connecting to ASIU

There are three Breakout Boxes available that simplify wire termination to the ASIU. There are two 44-pin type and one 15-pin type. The Breakout Box dimensions are shown in the following illustrations.

Dimensions - 44-Pin Breakout Box for AUX I/O and GEN I/O ASIU Connectors

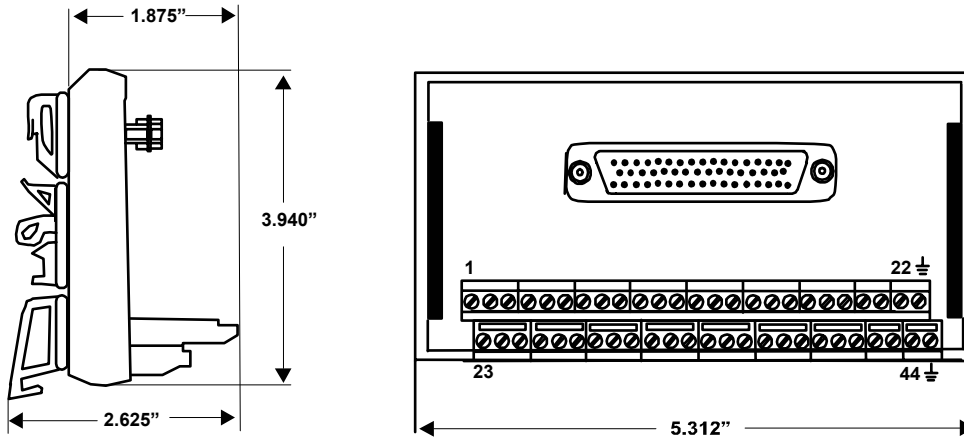

Dimensions - 15-Pin Breakout Box for Axis Port ASIU Connectors

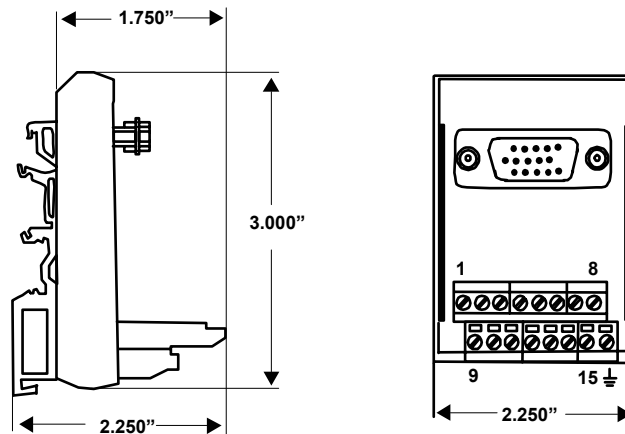

ASIU Mounting Dimensions

The ASIU is mounted to your cabinet using the mounting slots on the ASIU. The ASIU may be mounted vertically or horizontally. The recommended size of mounting hardware is #10 bolts with #10 star washers (to ensure proper ground connection).

ASIU Mounting Dimensions

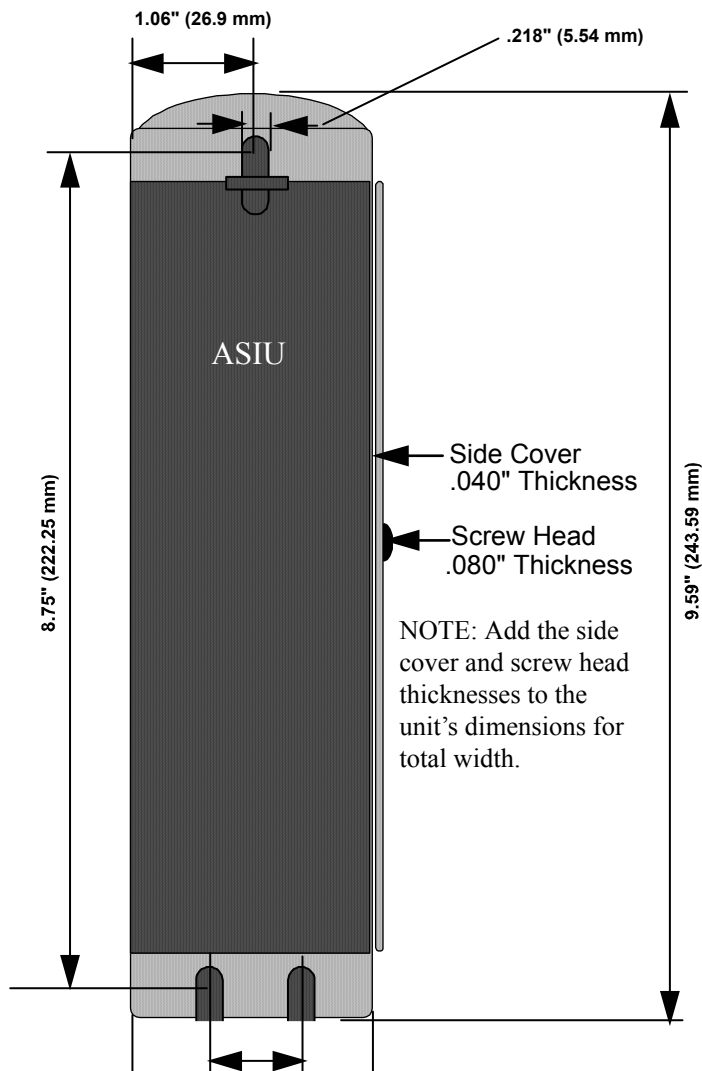

Optional Fieldbus Modules

The MMC for PC will accept a Fieldbus Module for network communications, either DeviceNet, Profibus, or Digital Line Shaft (DLS). The board is mounted 0.8" above the MMC for PC board. When the Fieldbus Module is mounted on the MMC for PC board, the combined unit will occupy two slots. The board is located so the network connector will be positioned in a slot aperture of the host PC.

NOTE

Throughout this document, "Fieldbus Module" is a generic term that refers to any communication module (DeviceNet, Profibus, or Digital Line Shaft (DLS)) that can be installed on the MMC for PC board. It does not refer to a specific type of communication network or module.

View from Component Side

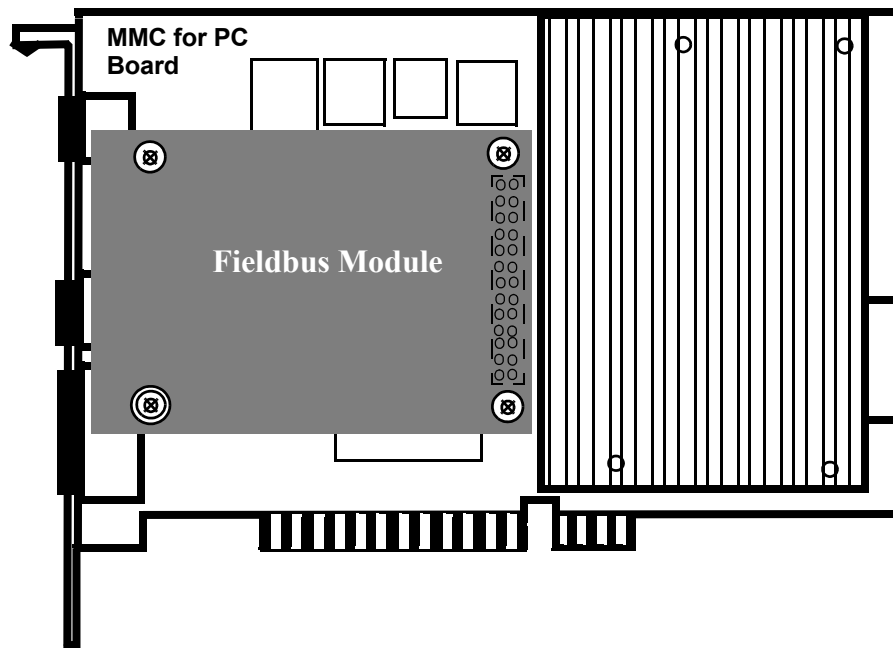

Optional Fieldbus Modules - Part Numbers

Description	Part Number
DeviceNet Module	M.1300.5981
DeviceNet Configuration Software	M.1300.7217
Profibus Module	M.1300.5984
Profibus Configuration Software	M.1300.7218
Digital Line Shaft (DLS) Module	M.1301.8981

DeviceNet Module

DeviceNet Connections

DeviceNet Network Configuration

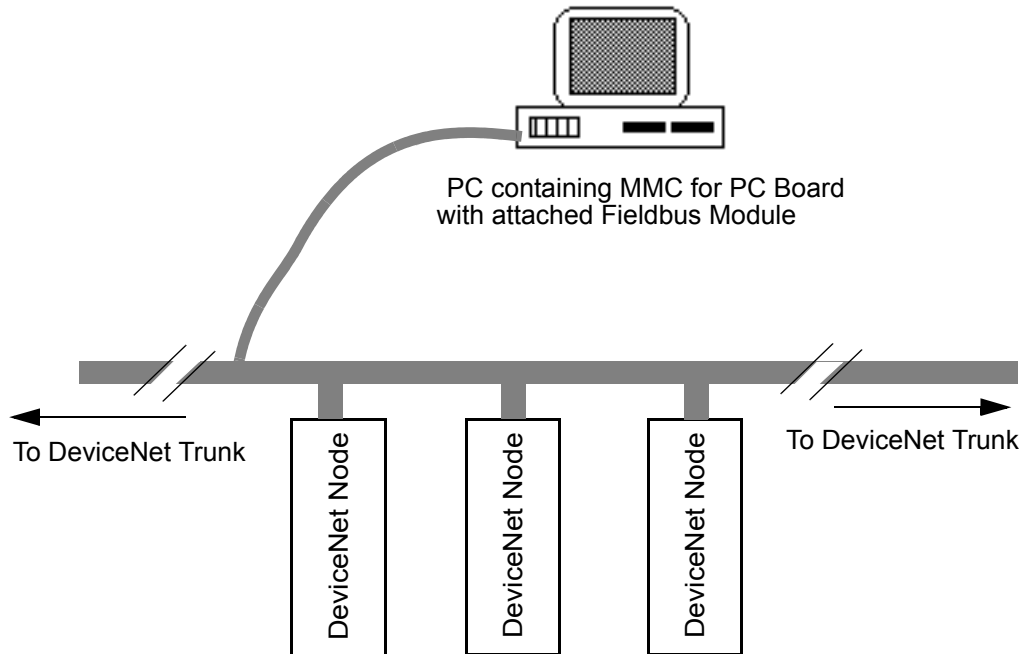

DeviceNet Port

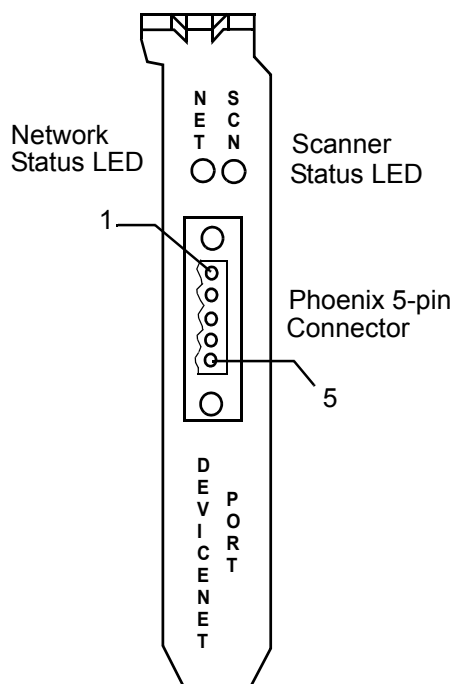

Pinout for DeviceNet Port		
Pin #	Signal Name	Wire Color
1	V-	black
2	CAN_L	blue
3	Shield (drain)	bare
4	CAN_H	white
5	V+	red

DeviceNet Module LEDs

LED	Color	State	Definition
Network Status	Green	OFF	Off-line
		ON	On-line and connected to all nodes
		Flashing	On-line but connection to all nodes not established
	Red	ON	Unrecoverable Fault (duplicate MAC ID check failed, critical bus fault, etc.)
		Flashing	I/O connections in timed-out state or other Recoverable Fault
Scanner Status	Green	OFF	No power or else reset asserted
		ON	Scanner OK and active
		Flashing	Scanner OK but not active
	Red	ON	Hardware or software error
		Flashing	Recoverable configuration error (invalid data downloaded)
	Orange	ON	Configuration (download) mode

Profibus Module

Profibus Connections

Profibus Network Configuration

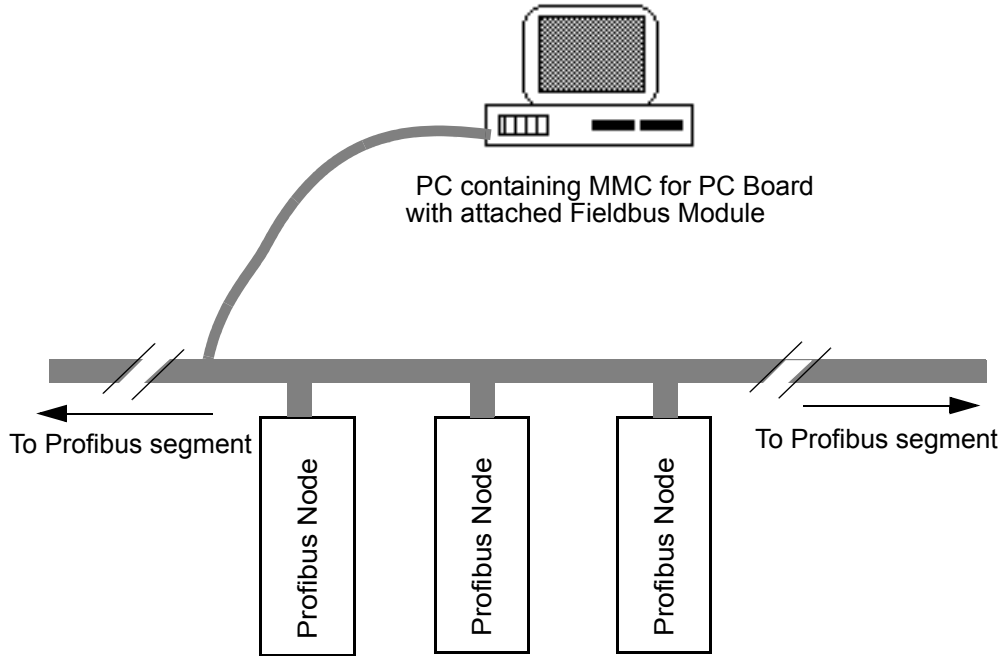

Profibus Port

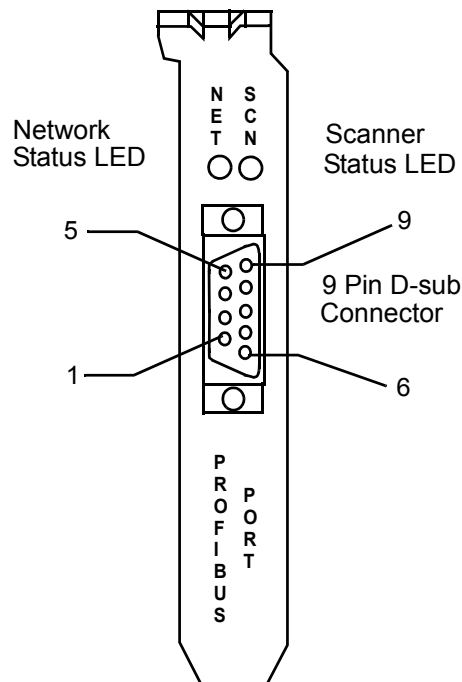

Pinout for Profibus Port	
Pin #	Signal Name
1	Chassis ground
2	Reserved
3	data +
4	Tx enable
5	Isolated ground
6	voltage +
7	reserved
8	data -
9	reserved

Profibus Module LEDs

LED	Color	State	Definition
Network Status	Green	OFF	Off-line
		ON	On-line and connected to all nodes
	Red	ON	On-line, but bus error (baud rate or wiring problem)
Scanner Status	Green	OFF	No power or else reset asserted, interface closed
		ON	Scanner OK and active (interface open)
	Red	ON	Interface open, at least one slave faulted
	Orange	ON	Configuration (download) mode

Digital Line Shaft (DLS) Module

Up to 256 SERCOS axes can be synchronized using the Digital Line Shaft (DLS) fieldbus module. The DLS master provides real-time communication of either actual or commanded position of the system master axis (time or real servo axis) as well as registration offset and E-Stop status to all Digital Line Shaft slaves.

DLS Connections

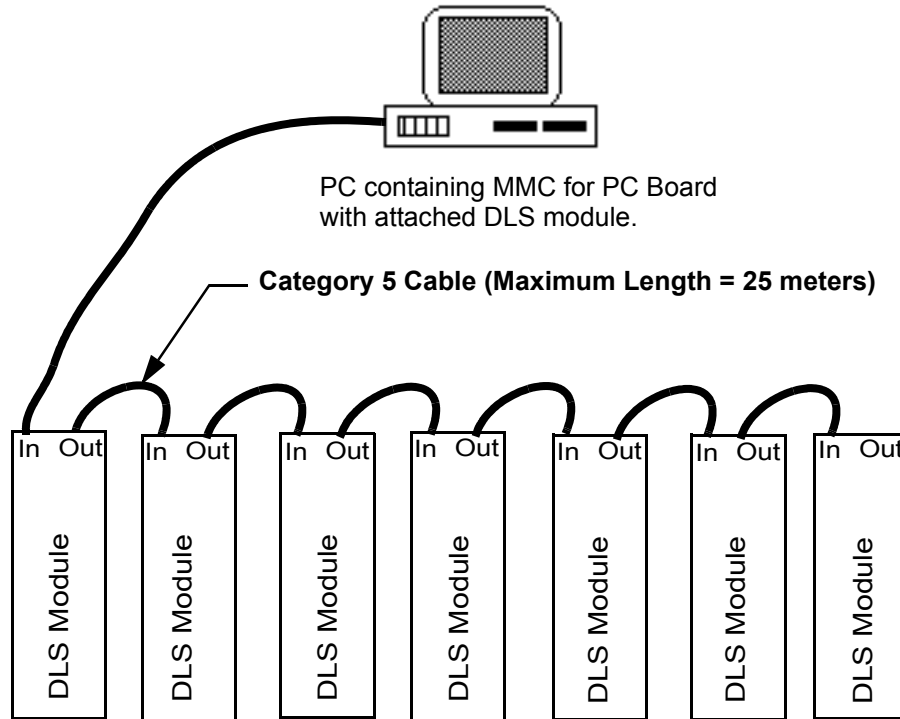

Up to 8 MMC for PCs with Digital Line Shaft Modules can be connected as shown above. Each module resides on an MMC for PC SERCOS board.

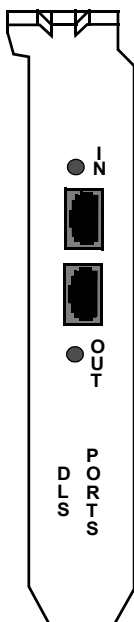

The DLS ports use RJ-45 style 8-pin connectors using 100 ohm unshielded twisted pair category 3 or 5 cable (IEEE 802.3 Section 14.4). The maximum length of the twisted pair cable segment is 25m (82.5 ft.).

NOTE: The connector is also suitable for shielded cable and will ground the shield to the chassis.

NOTE: The DLS Module can only be used the MMC for PC-S8 (P/N M.1301.4102), MMC for PC-S16 (P/N M.1301.4103), or MMC for PC-S32 (P/N 1301.4104).

DLS Module LEDs

In Link OK(IN OK) Green	
ON	Indicates that there is a DLS Module properly connected and communicating with this DLS Module's IN port.
OFF	Indicates that there is not a DLS Module properly connected and communicating with this DLS Module's IN port.
Out Link OK(OUT OK) Green	
ON	Indicates that there is a DLS Module properly connected and communicating with this DLS Module's OUT port.
OFF	Indicates that there is not a DLS Module properly connected and communicating with this DLS Module's OUT port.

Specification Tables

MMC for PC Analog Board Specifications

Servo Update Rates						
	Update Rates					
	8 ms	4 ms	2 ms	1 ms	.5 ms	.25 ms
Maximum number of axes*	32	32	32	24/12	12/6	6/3
Maximum number of ASIUs	8	8	8	6	3	2

*Where two numbers are listed they represent High/Low. The High number is typical when running RATIO_GR, RATIOCAM, VEL_STRT, POSITION, DISTANCE move types etc... The Low number is typical when running time axes, servo tasks, RATIO_RL, M_LINCIR, M_SCRVLC move types etc... The Low number types place a heavier burden on CPU time than the High number types.

General	
Part Number	Use MMC for PC Analog Package M.1301.3089
System Requirements	One PCI Local Bus slot, Standard 2.1 compatible, 133MHz Pentium or faster
Processor Speed	128MHz
Board Dimensions	6.6" L x 4.2" H
Flash Memory	1 MB
RAM Memory	1MB (Refer to the PiCPro for Windows Software Manual for partitioning, RAM into Application, RAM Disk and Variable Memory storage areas)
Input voltage range	+20 VDC to 30 VDC (absolute maximum), 24V nominal
Input power	6.5 W @ 24V (.27 amps), PCI bus derived or external
Environmental	
Operating temperature range	0°C to 55°C (32° F to 131°F)
Storage temperature range	-40°C to 85°C (-40°F to 185°F)
Humidity	5 to 95%, non-condensing

Conformity	
CE Marked	<p>Conforms to Directives 73/23/EEC, 89/336/EEC, 92/31/EEC, 93/68/EEC by conforming to the following standards:</p> <p>EN 50081-2:1993 EMC Generic Industrial Emissions EN 50082-2:1995 EMC Generic Industrial Immunity EN 61131-2:1994/A11:1996 Low voltage directive requirements for programmable controllers</p> <p>Operates with emissions below EN55011/ CISPR 11 Class A limits</p> <p>Immune to:</p> <ul style="list-style-type: none"> • Electrostatic discharge (4K V contact mode, 8K V air discharge) per EN61000-4-2 • RF electromagnetic fields per EN61000-4-3, ENV 50141, and ENV50204 • Electrical fast transients per EN61000-4-4 • Magnetic fields per EN61000-4-8 <p>Refer to the EMC Guidelines for more information.</p>
UL and C/UL Listed	File No. E126417 NRAQ Programmable Controllers

MMC for PC SERCOS Board Specifications

Servo Update Rates				
	Update Rates			
	8 ms	4 ms	2 ms	1 ms
Maximum number of axes	32	32	16	8

General	
Part Number	MMC for PC-S8 (8 axes) M.1301.4102 MMC for PC-S16 (16 axes) M.1301.4103 MMC for PC-S32 (32 axes) M.1301.4104
System Requirements	One PCI Local Bus slot, Standard 2.1 and 2.2 compatible 133MHz Pentium or faster
Processor Speed	128Mhz
Board Dimensions	6.6" L x 4.2" H
Flash Memory	1 MB
RAM Memory	1MB (Refer to the PiCPro for Windows Software Manual for partitioning RAM into Application, RAM Disk and Variable Memory storage areas)
Input voltage range	+20 VDC to 30V DC (absolute maximum), 24V nominal
Input power	6.5 W @ 24V (.27 amps), PCI bus derived or external

Environmental	
Operating temperature range	0°C to 55°C (32° F to 131°F)
Storage temperature range	-40°C to 85°C (-40°F to 185°F)
Humidity	5 to 95%, non-condensing

Conformity	
CE Marked	<p>Conforms to Directives 73/23/EEC, 89/336/EEC, 92/31/EEC, 93/68/EEC by conforming to the following standards:</p> <p>EN 50081-2:1993EMC Generic Industrial Emissions EN 50082-2:1995EMC Generic Industrial Immunity EN 61131-2:1994/A11:1996 Low voltage directive requirements for programmable controllers</p> <p>Operates with emissions below EN55011/ CISPR 11 Class A limits</p> <p>Immune to:</p> <ul style="list-style-type: none"> • Electrostatic discharge (4K V contact mode, 8K V air discharge) per EN61000-4-2 • RF electromagnetic fields per EN61000-4-3, ENV 50141, and ENV50204 • Electrical fast transients per EN61000-4-4 • Magnetic fields per EN61000-4-8 <p>Refer to the EMC Guidelines for more information.</p>
UL and C/UL Listed	File No. E126417 NRAQ Programmable Controllers

ASIU Specifications

General	
Part Number for ASIU-2	M.1300.5970
Part Number for ASIU-4	M.1300.4422
IN and OUT RJ45 ports	RJ45 port, secured protocol
Input voltage range	+20 VDC to 30 VDC (absolute maximum), 24V nominal
Input power	350 mA plus I/O power
Operating temperature range	5°C to 55°C (41°F to 131°F)
Storage temperature range	-40°C to 85°C (-40°F to 185°F)
Humidity	5 to 95%, non-condensing
Maximum length of cable between MMC for PC Analog board and first ASIU	82.5 ft.(25 m)
Maximum length of cable between two ASIUs	82.5 ft.(25 m)
Type of cable between MMC for PC Analog board and first ASIU	CAT5 straight pinned. Use shielded cable in noisy environments.
Type of cable between two ASIUs	CAT5 straight pinned. Use shielded cable in noisy environments.

MMC for PC DeviceNet Module Specifications

General	
Part Number	M.1300.5981
Function	Interfaces to a DeviceNet network with up to 63 other nodes.
DeviceNet Port	Phoenix style 5-pin male connector
Supply Voltage Range	4.75 V to 5.25 V
Supply Current (steady state)	500 mA maximum (250 mA typical)
Peak Supply Current	750 mA
Vibration (per IEC 68-2-6)	10-57 Hz (constant amplitude .15 mm) 57 - 2000 Hz (acceleration 2 g)
Shock (per IEC 68-2-27)	Four shocks per axis (15g/11 msec)
Environmental	
Operating Ambient Temperature	0°C to 60°C (32° F to 140°F)
Non-operating Ambient Temperature	-25°C to 70°C (-13° F to 158°F)
Operating Humidity	5 to 95% non-condensing
Conformity	
CE Marked	<p>Conforms to Directives 73/23/EEC, 89/336/EEC, 92/31/EEC, 93/68/EEC by conforming to the following standards:</p> <p>EN 50081-2:1993EMC Generic Industrial Emissions EN 50082-2:1995EMC Generic Industrial Immunity EN 61131-2:1994/A11:1996 Low voltage directive requirements for programmable controllers</p> <p>Operates with emissions below EN55011/ CISPR 11 Class A limits</p> <p>Immune to:</p> <ul style="list-style-type: none"> • Electrostatic discharge (4K V contact mode, 8K V air discharge) per EN61000-4-2 RF electromagnetic fields per EN61000-4-3, ENV 50141, and ENV50204 • Electrical fast transients per EN61000-4-4 • Magnetic fields per EN61000-4-8. Refer to the EMC Guidelines for more information.
	File No. E126417 NRAQ Programmable Controllers

MMC for PC Profibus Module Specifications

General	
Part Number	M.1300.5984
Function	Interfaces to a Profibus network with up to 31 other nodes, without a repeater.
Profibus Port	9-pin D-sub female connector
Supply Voltage Range	4.75 V to 5.25 V
Supply Current (steady state)	500 mA maximum (250mA typical)
Peak Supply Current	750 mA
Vibration (per IEC 68-2-6)	10-57 Hz (constant amplitude .15 mm) 57 - 2000 Hz (acceleration 2 g)
Shock (per IEC 68-2-27)	Four shocks per axis (15g/11 msec)
Environmental	
Operating Ambient Temperature	0°C to 60°C (32° F to 140°F)
Non-operating Ambient Temperature	-25°C to 70°C (-13° F to 158°F)
Operating Humidity	5 to 95% non-condensing
Conformity	
CE Marked	<p>Conforms to Directives 73/23/EEC, 89/336/EEC, 92/31/EEC, 93/68/EEC by conforming to the following standards:</p> <p>EN 50081-2:1993EMC Generic Industrial Emissions EN 50082-2:1995EMC Generic Industrial Immunity EN 61131-2:1994/A11:1996 Low voltage directive requirements for programmable controllers</p> <p>Operates with emissions below EN55011/ CISPR 11 Class A limits</p> <p>Immune to:</p> <ul style="list-style-type: none"> • Electrostatic discharge (4K V contact mode, 8K V air discharge) per EN61000-4-2 • RF electromagnetic fields per EN61000-4-3, ENV 50141, and ENV50204 • Electrical fast transients per EN61000-4-4 • Magnetic fields per EN61000-4-8 <p>Refer to the EMC Guidelines for more information.</p>
UL and C/UL Listed	File No. E126417 NRAQ Programmable Controllers

MMC for PC Digital Line Shaft (DLS) Module Specifications

General	
Part Number	M.1301.8981
Function	Interfaces up to 8 Digital Line Shaft Modules as part of a cluster of up to 8 MMC for PC systems.
DLS Ports	Two RJ45 Shielded Connectors, one for Input, one for Output.
Supply Voltage Range	4.75 V to 5.25 V
Supply Current (steady state)	500 mA maximum (250mA typical)
Peak Supply Current	750 mA
Vibration (per IEC 68-2-6)	10-57 Hz (constant amplitude .15 mm) 57 - 2000 Hz (acceleration 2 g)
Shock (per IEC 68-2-27)	Four shocks per axis (15g/11 msec)
Environmental	
Operating Ambient Temperature	0° C to 55° C (32° F to 131° F)
Non-operating Ambient Temperature	-25° C to 70° C (-13° F to 158° F)
Operating Humidity	5 to 95% non-condensing
Conformity	
CE Marked (Pending)	<p>Conforms to Directives 73/23/EEC, 89/336/EEC, 92/31/EEC, 93/68/EEC by conforming to the following standards:</p> <p>EN 50081-2:1993EMC Generic Industrial Emissions EN 50082-2:1995EMC Generic Industrial Immunity EN 61131-2:1994/A11:1996 Low voltage directive requirements for programmable controllers</p> <p>Operates with emissions below EN55011/ CISPR 11 Class A limits</p> <p>Immune to:</p> <ul style="list-style-type: none"> • Electrostatic discharge (4K V contact mode, 8K V air discharge) per EN61000-4-2 • RF electromagnetic fields per EN61000-4-3, ENV 50141, and ENV50204 • Electrical fast transients per EN61000-4-4 • Magnetic fields per EN61000-4-8 <p>Refer to the EMC Guidelines for more information.</p>
UL and C/UL Listed	File No. E126417 NRAQ Programmable Controllers