



Initial DriveShaft Installation

Proper DriveShaft installation is a critical part of ensuring a successful application. Please use the information on this sheet to help ensure success.

When setting up the system - aligning actuators, etc. - it is not necessary to fully torque the DriveShaft clamping collars. However, **proper torque of the of the clamp screws is critical** for the final installation. The DriveShaft is typically installed concurrently with the X-axis and X'-axis actuators so that no disassembly of the DriveShaft is required.

Degrease the inner bore of the DriveShaft hubs and outer diameter of the stub shafts. However, do not degrease the collar or collar hardware; A clean rag may be used to wipe the parts clean. Put the DriveShaft between the X-axis and X'-axis actuators before both of them are secured. Leave the clamping collars loose while aligning the system . **Heed the maximum misalignment rating while adjusting actuator positions.**

Proper DriveShaft alignment

The Drive Shaft couplings allow for a maximum of 1° angular misalignment at each coupling and up to ±0.030 inches [±0.76mm] end float total. It is recommended at installation that no more than 1/4° misalignment be allowed. This avails the remaining misalignment capacity of the couplings to accommodate vibration, thermal expansion, etc. The following chart gives angular misalignments resulting from parallel stub shaft offsets as a function of DBXC. DBXC is given in the Drive Shaft part number, R3-DS-XX.XX or R4-DS-XX.XX, where XX.XX = DBXC in inches. Remember that the total angular misalignment is made up not only of that which results from parallel misalignment but also from actual angular misalignment as well.

Final DriveShaft Installation

Align the outside collar face with the face of the hub. Keep the gaps between the collar halves equal while lightly tightening the collar screws. Initially torque both screws to 60in-lbf. Finally torque both screws of each collar to 170in-lbf.

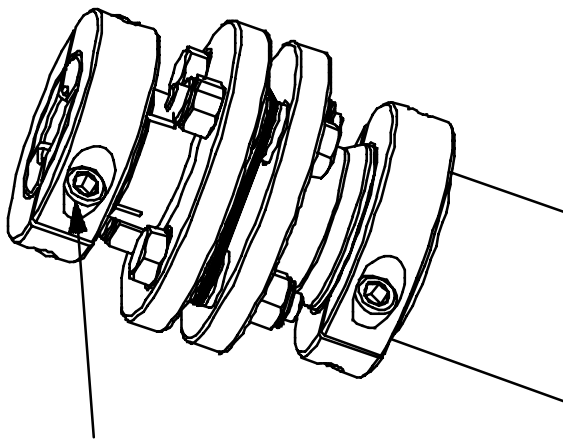

Properly Tighten the DriveShaft Collar Clamps

- **Initial Torque: 60 in-lbf [6.7 N-m]**
- **Final Torque: 170 in-lbf [19.2 N-m]**

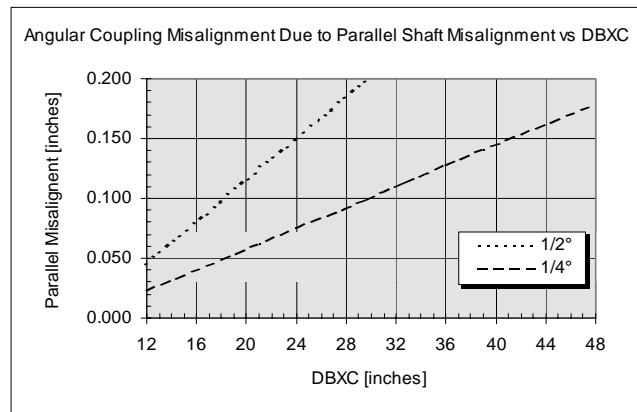

Properly Align the DriveShaft