

# FUSION FX4000

**Seco**  
AC/DC Drives



**AC Servo Performance Drives/Systems**

**April 2004 Release**

[www.secodrives.com](http://www.secodrives.com)  
1-704-588-5693

**Solutions by**  
**DANAHER**  
MOTION

# Mechanical and Electro-Mechanical Product Solutions by Danaher Motion

Danaher Motion engineers, manufactures and markets a select combination of the world's top brands of mechanical and electro-mechanical products. Our principal brands and products include:

- **THOMSON** industrial, precision and rodless actuators, linear slide tables and systems, ball and lead screws, linear bearings and guides, precision balls, shafting and integrated solutions
- **MICRON** gearheads
- **DELTRAN PT** electromagnetic friction and wrap spring clutches and brakes
- **SUPERIOR ELECTRIC** stepper and servo motors and controls
- **SECO AC and DC** variable speed drives

Designed to help increase productivity and improve performance, our products are incorporated into new equipment designs as well as machines already in service. From semiconductor assembly, packaging, robotics and industrial automation to medical, fitness and mobile off-highway equipment, our mechanical and electro-mechanical products bring flexibility, precision, efficiency, and reliability to a wide variety of industries.

Beyond our world-class product designs, one of our greatest strengths is our commitment to the Danaher Business System (DBS), which is comprised of a unique set of robust, repeatable processes that help us constantly improve the operational efficiency of our factories. Based upon the time-tested methods of Kaizen, the DBS is a team-based mindset that continuously and aggressively eliminates waste in every facet of our business operations. Furthermore, the DBS focuses the entire organization on breakthrough objectives that culminate in maintainable, results-oriented business processes, which, in turn, create advantages for our customers in the areas of quality, delivery and performance.

At Danaher Motion, we bring together best-in-class products, unsurpassed customization expertise, and innovative solutions to significantly improve and revolutionize the way things move. We are the experts in motion control. In short, Danaher Motion offers more choices, more application expertise and more integrated solutions than anyone else in the market.

**THOMSON**

**MICRON**

**Deltran PT**

**Superior  
Electric**

**Seco**  
AC/DC Drives



**NEMA 4,  
Dynamic Braking,  
DC Bus Choke  
and Line Fuses  
Standard**

## What's a Fusion Drive?

Fusion Drive is our newest, all-digital drive series that combines the four most useful motor control technologies in one package:

- High Performance AC Flux Vector Drive
- High HP Servo Drive
- Programmable Motion Controller
- Programmable Logic Controller (PLC)



### Motor-Independent Application Flexibility

The all-digital Fusion FX4000 drives utilize a unique drive architecture that enables them to control most any AC induction, AC synchronous, or brushless DC motor. One drive fits all your drive needs for motors from one to 350 HP! Fusion FX4000 drives are extremely application-flexible. In addition to their ability to control different motor types, including servo motors in torque, velocity, or position control modes, they also provide extensive analog and digital I/O, feedback, and serial communication capabilities.

### Application-Specific Firmware

Fusion firmware tailors specific drive features and operation to the task at hand. FX4000 software is available for such applications as traversing, indexing, cut-to-length, tension control, elevators, press feeders, and wire drawing, to name a few. And further customization is possible with many programs by using our UEdit™ Windows-based programming tool that allows users to extend their applications using ladder diagrams and function blocks.

### Easy Set-Up and Monitoring

Fusion drives provide a simple-to-use auto-tuning feature that adjusts virtually all motor and inertial parameters to the motor and connected load. Enter a few values from the motor nameplate, and the advanced setup routines do the rest. The drive is completely tuned within minutes! A keypad and LCD provide a straightforward operator interface for setting and viewing all operating parameters and diagnostics. Messages and time-stamped fault logs are displayed in plain, easily understood language.

### Energy Savings and Power Quality

Multiple Fusion drives can be operated from a common bus, enabling the recovery of regenerated energy for a more energy efficient system. The Fusion FX4000 provides near-unity power factor and low harmonic currents at all motor speeds. High-power units (60 HP and higher) offer a six-phase (12-pulse) configuration that further minimizes line harmonics in critical applications.

### Compact and Rugged Packaging

Fusion FX4000 drives are available in either enclosed NEMA 4/12 (to 50 HP/460V), NEMA 1 (60 HP and above) or open chassis. Either version can be foot- or flange-mounted. High speed current limiting fuses are standard through 50 HP/460V, and dynamic braking control is provided on all models.



Try the  
**Fusion Solution**  
on your next  
**X-treme  
Servo  
Application**

## Advanced Technology for Superior Performance

Fusion drives incorporate the latest in IGBT power devices and digital signal processors (DSP). These are coupled in the FX4000 series with advanced space vector and motion control techniques to deliver optimum motor performance, complete programmability, and simplicity of operation.

## Multiple Communications Options

Two fully isolated RS-422/485 serial interfaces are provided for connecting the drive to a process controller, communication network, or programmable controller, and an RS-232 port is also provided for connecting to a PC. ModBus RTU is standard, and optional UEdit Lite™ drive management software enables a network of drives to be set up, monitored, and controlled from a single Windows-based PC.

## Multiaxis Operation

A built-in, high-speed synchronous communication port allows precise coordination of multiple drive axes. Optional master/slave software enables easy control of individual motor velocity ratios and position phasing relative to the master.

## Transducer or Transducer-less Operation

Fusion FX4000 drives can operate with or without a feedback transducer. Encoders or resolvers are supported, and transducer-less operation is possible for less demanding velocity-loop applications. A dual incremental encoder port is available as an option for precision follower applications.

## General

- All-digital control for zero drift and repeatable motor operation
- 24-bit DSP computational power for fast, dynamic response
- High switching frequency IGBT devices for quiet, efficient operation
- Digital current regulator for high-speed operation and fast response
- Space vector control for reduced motor noise and low current ripple
- Flux vector control for full 4-quadrant torque from zero to rated speed
- Servo control for precise velocity, position, or torque control
- Field weakening at constant horsepower up to four times base speed
- Dynamic braking control in all models
- Drive/motor packages available for up to 400% peak torque
- DC Bus choke standard in ALL units
- High speed current-limiting fuses in units 1-50 HP @ 460 VAC
- Line Regenerative units available, consult factory

## Ease of Installation, Setup, and Maintenance

- Automated setup features require no chart recorders or meters
- Software calibration and adjustment eliminate tuning components
- Digital parameter adjustment for precise and repeatable settings
- Software input and output scaling eliminates potentiometers
- Identical control boards in all models reduces spare parts
- Complete, self-contained package requires few option boards
- AC line fuses included through 50 HP/460V

## Ease of Use

- Full keypad for easy entry of application-specific setup adjustments
- Two line by 20-character/line descriptive, plain-English display with back-lighting
- Comprehensive plain-language, self-diagnostic message display
- Real-time motion information and historical fault log
- RS-232/422/485 for communication with process controllers
- ModBus RTU standard
- Optional UEdit Lite™ software for managing the drive from a personal computer
- UEdit™ software allows user to design and modify application firmware and create your own custom display menu

## Reliable Operation

- Tolerant of AC line fluctuations
- Extensive electronic protection circuits reduce failures – 4th generation Intelligent Power Modules used through 50 HP/460V
- Optically isolated signals for high noise immunity
- S-curve acceleration reduces shock and extends equipment life



## Application-Specific Firmware For Your Next X-treme Application

Fusion firmware tailors specific drive features and operation to the task at hand. FX4000 software is available for such applications as traversing, indexing, cut-to-length, tension control, elevators, press feeders, and wire drawing, to name a few. And further customization is possible with many programs by using our UEdit™ Windows-based programming tool that allows users to extend their applications using ladder diagrams and function blocks.

### Traversing Applications

Traversing firmware provides for repetitive linear motion, either coordinated with a line speed, or to a preset speed profile. Inputs for end-of-stroke sensors are provided, as is the capability to pre-program a fixed stroke length without the need for sensors. Multiple speed profiles may be programmed for applications requiring more complex finished packages.

- Wire Spooler
- Bobbin Winder
- Spray gun
- Welding
- Level Wind Coiler
- Lapper Control



Wire Industry

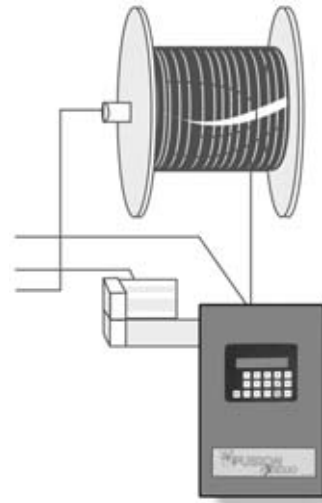

### Position/Indexer Applications

Position/Indexer firmware includes the capability for controlled moves to up to 31 positions. Either incremental or absolute positioning may be performed, with multiple sets of accel, decel, jerk, and settle times. Teach mode allows the user to load the drive's current position into memory for easy setup. It is possible to program complex timed sequences using the optional UEdit software package.

- Pick and Place
- Bottle Capper
- Rotary Table
- Star Wheel
- Shaft Lock
- Transfer Feed
- Elevator/Hoist
- Spindle Orientation



Automotive Assembly

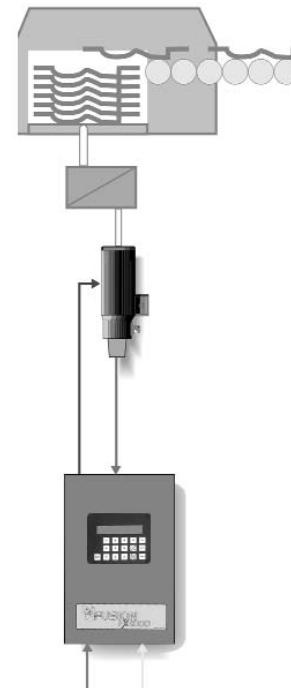

## Cut-To-Length Applications

Feed-To-Stop firmware allows full control of roll feed applications. The powerful Synchronous Profile mode allows the feeder to operate "electronically line-shafted" to the press or shear, maximizing feed angle, and therefore through-put. Batching capability may be used to produce a pre-determined number of cuts, and press cam outputs are provided to replace existing mechanical cam switches. Single Stroke Profile mode may be selected for applications which provide a "feed initiate" command and wait for a "feed complete" output.

- Feed to Stop
- Sheeter
- Stacker
- Rotary Cutoff



Sheet Metal Cutoff

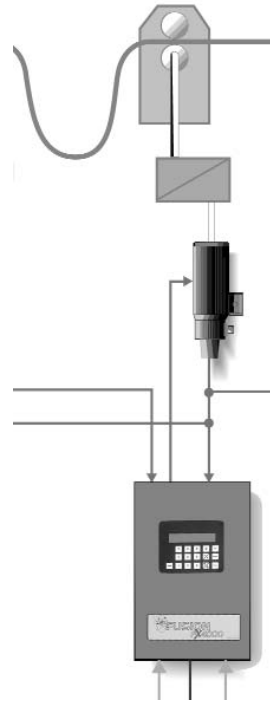

## Tension Control Applications

Firmware for web handling systems includes coil diameter calculation, including compensation for changes in mass and inertia as the coil changes. Over/under control and tension setup provides flexibility on the production floor and ease of setup. Material counter allows a preset amount of material to be wound or paid off, and provides an "early warning" output to the operator. Programmable parameter sets provide for virtually any tension control scenario.

- Rewinder
- Unwinder
- Loop/Leveler



Textile Beamer

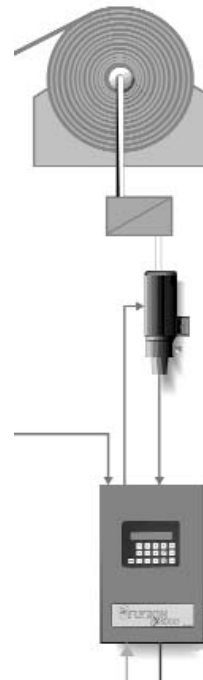

**Fusion FX4000 takes on the needs of your application with application-specific firmware. Choose from Indexer, Traverse, Velocity/Torque Control, Cut-to-Length, Coiler, Rotary Cutoff, Crane Hoist and more.**

DANAHER MOTION is a trademark.

Danaher Motion makes every attempt to ensure accuracy and reliability of the specifications in this publication. Specifications are subject to change without notice. Danaher Motion provides this information "AS IS" and disclaims all warranties, express or implied, including, but not limited to, implied warranties of merchantability and fitness for a particular purpose. It is the responsibility of the product user to determine the suitability of this product for a specific application.

©2004 Danaher Motion.

**Seco**  
 AC/DC Drives

UEdit™ is a suite of tools for customizing, monitoring, and managing the Fusion Drive's embedded drive applications. The software, which runs on a Windows-based personal computer, lets users tailor an application to their needs without affecting the core program. This provides greater control over integration as well as the independence to make engineering changes at any time. Powerful diagnostic, simulation, and archiving tools help minimize downtime and facilitate start-ups. UEdit™ software is sold separately, and may be used for multiple Fusion units.

drive in the event of a failure.

### Project View

Project View reveals the architecture of a UEdit™ project at a glance. User-defined tasks, such as ladders and function blocks, are grouped according to the clock levels assigned to them. This allows code to be partitioned into meaningful segments that can be displayed simultaneously during monitoring or simulation.

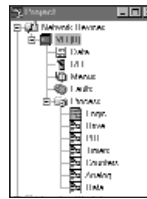

### Ladder Editor (IEC 1131-3 Format)

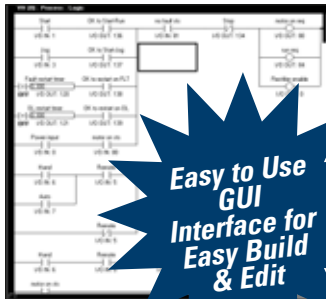

**Easy to Use  
 GUI  
 Interface for  
 Easy Build  
 & Edit**

The Ladder Editor lets users build ladder logic in a PLC-like environment to control or modify embedded drive functions. The graphical editor provides both on-line monitoring and off-line simulation modes. Standard programmable controller features, such as contacts, coils, timers, and data read and write functions are supported.

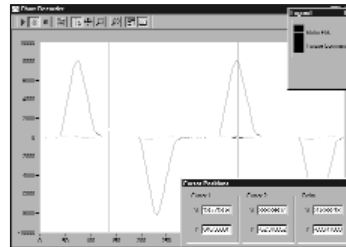

### Chart Recorder

The Chart Recorder monitors drive performance in real time. Four channels can be displayed simultaneously in several user-definable formats. Predefined signals, data, and I/O from varying clock levels may be monitored. Chart data can also be exported to a file for use by other programs

such as Microsoft Excel™.

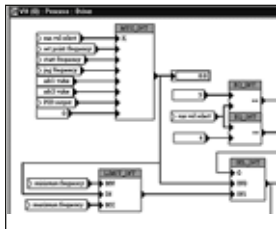

### Function Block Editor

The Function Block Editor extends programming flexibility by allowing mathematical computations, boolean logic, counters, comparisons, timers, and other functions to be included in applications. More than 70 predefined function blocks are provided, and users

can create their own. The editor features an intuitive drag-and-drop environment.

### Additional Features

- Helpful application download wizard makes upgrading core embedded applications easy
- Automatically detects new devices and program changes within devices
- Multidrop capabilities for maintaining simple local networks
- Identifies network devices and reports their attributes
- Built-in help menu
- Revisions are upwardly compatible and load without necessitating downtime

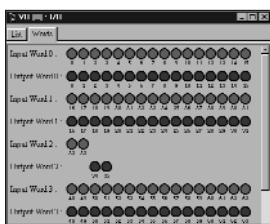

### I/O View

The I/O View displays the status of application inputs and outputs and lets users manipulate them. Bits can be viewed by name or graphically by word. Individual bits may be set, cleared, or forced on or off.

### Minimum Requirements

- FX4000 Fusion drive
- Computer with Windows 98 or NT/2000 operating system
- 200 MHz Pentium processor
- 32 MB of application RAM
- 10 MB of available hard drive space for standard installation
- CD-ROM drive for installation
- Serial communications port
- Monitor
- Mouse
- Keyboard

ADDR	NAME	TYPE	ADDRESS	FUNCTION/COMMENT	STATUS
1000	user system	IN1	1	1 NUL (E)1	
1001	position limit	IN1	1	1000	
1002	velocity limit	IN1	1	1000	
1003	torque limit	IN1	1	1000	
1004	speed frequency	IN1	1	1000	
1005	max accel	IN1	1	1000	
1006	operational	IN1	1	1000	
1007	no load multibit	IN1	1	1000	
1008	water return	IN1	1	1000	
1009	operational control	IN1	1	1000	
1010	operational control	IN1	1	1000	
1011	operational control	IN1	1	1000	
1012	enable the gun	IN1	1	1000	
1013	enable modulation	IN1	1	1000	
1014	enable the event	IN1	1	1000	
1015	enable window adjust	IN1	1	1000	
1016	enable window limit	IN1	1	1000	
1017	enable the gun	IN1	1	1000	
1018	enable modulation	IN1	1	1000	
1019	enable the event	IN1	1	1000	
1020	enable window adjust	IN1	1	1000	
1021	enable window limit	IN1	1	1000	
1022	enable the gun	IN1	1	1000	
1023	enable modulation	IN1	1	1000	
1024	enable the event	IN1	1	1000	
1025	enable window adjust	IN1	1	1000	
1026	enable window limit	IN1	1	1000	
1027	enable the gun	IN1	1	1000	

### Data View

The Data View displays all setup and readout parameters in a device along with their values and other attributes. Parameter units may be changed globally within a device with the click of a button. Variables may also be dragged to the function-block or ladder-editor windows

when programming. A complete record of drive data can be permanently archived or printed for safekeeping and restored on the

## Input Supply

### Line Voltage:

200 to 240, 380 to 480 V AC, 3-phase

Phase sequence insensitive

### Voltage tolerance:

-10% of minimum, +10% of maximum

### Frequency:

47 to 63 Hz

### Power factor:

Displacement: .97 and > at all loads and speeds

Overall: 0.94 at rated load

## Output Rating

### Voltage:

Zero to input voltage, 3-phase

### Frequency:

Zero to 120 Hz for transducerless vector control

Zero to 240 Hz for transducer-based vector control

### Switching frequency:

Programmable from 1.9 to 12.0 KHz

## Service Conditions

### Efficiency:

97% nominal at rated switching frequency

### Overload current:

Constant/Servo torque: 150% of rated for 1 min, maximum of

200(+) % of rated

### Regeneration:

Dynamic braking transistor with optional resistors. Internal resistors for limited braking on 1-7.5 HP/460V

Note: Consult factory for common bus applications

## Environmental

### Operating temperature:

Control Section: 32° to 131° F (0° to 55° C)

Heat sink: 32° to 131° F (0° to 55° C)

32° to 104° F (0° C to 40° C) enclosed units

32° to 131° F (0° C to 55° C) chassis units

### Storage temperature:

5° to 158° F (-15° to 70° C)

### Relative humidity:

95% maximum, noncondensing

### Altitude:

To 3,300 ft. (1,000 m) without derating

## Performance

### Position Control

#### Bandwidth:

50 Hz

#### Settle time:

10 ms

### Velocity Control

#### Bandwidth:

100 Hz with transducer

10 Hz without transducer

#### Range:

Zero to base speed at full torque

Base speed to 240 Hz at constant power with transducer

Base speed to 120 Hz at constant power without transducer

#### Resolution:

.025% with analog input (11 bit plus sign)

.01% with digital input

#### Regulation:

+/-0.001% of base speed, down to zero, with transducer

+/-0.5% of base speed, 80:1 Constant Torque speed range, without transducer (motor dependent)

### Torque Control

Peak torque: Zero to 200(+) % of rated

Constant torque: Zero to 150% of rated, 60 seconds.

### Regulation:

+/-3.0% of maximum with transducer

+/-10% of maximum without transducer

### Bandwidth:

300 Hz with DCR control

100 Hz with DSV control

## Transducer Options

A motor-mounted incremental encoder or resolver and corresponding interface module may be used for highest performance. The resolver interface provides encoder emulation for paralleling feedback to other devices. A dual-encoder option is also available for position-following applications.

## Inputs and Outputs

### Analog Inputs

- Three (3) 12-bit analog inputs (+/-10 V DC or 0 to 20 mA)

- Analog Interface Module: Additional eight (8) 12-bit analog inputs (0 to +10 V DC or 0 to 20 mA)

Note: Transducerless operation only

### Analog Outputs

- Two (2) 12-bit analog outputs (+/-10 V DC and 0 to 20 mA)

- Analog Interface Module: Additional four (4) 12-bit analog outputs (+/-10 V DC)

Note: Transducerless operation only

### Digital Inputs

- Twelve (12) digital inputs (require sink of 1 mA to common)

### Digital Outputs

- Three (3) standard digital outputs (Form C contacts rated 250 V AC @ 5 A, Form A contact rated 250 V AC @ 5 A, and open-collector driver rated 24 V DC @ 500 mA)

- Six (6) digital outputs (open-collector drivers rated 24 V DC @ 500 mA)

## Serial Communications

### Asynchronous

#### Port(s):

EIA RS-232/422/485, isolated, full duplex

Auxiliary RS-422/485, isolated, full duplex

#### Baud Rate:

RS-232 = 19.2 Kb, RS-485 = 9.6/19.2 Kb (Console port)

RS-485 aux. = Up to 115 Kb

#### Standard Protocol:

Modbus RTU, A-B DF1, ANSI 3.28

### Synchronous

#### Port:

EIA RS-485 for high-speed master/slave networking

## Protection

- Ground fault
- Motor phase-to-phase short circuit
- DC bus overvoltage
- DC bus undervoltage
- Instantaneous overcurrent
- Motor overload
- Heat sink overtemperature
- Ambient overtemperature
- Power transistor fault
- Logic power undervoltage
- Memory malfunction
- Processor not running fault

DANAHER MOTION is a trademark.

Danaher Motion makes every attempt to ensure accuracy and reliability of the specifications in this publication. Specifications are subject to change without notice. Danaher Motion provides this information "AS IS" and disclaims all warranties, express or implied, including, but not limited to, implied warranties of merchantability and fitness for a particular purpose. It is the responsibility of the product user to determine the suitability of this product for a specific application.

©2004 Danaher Motion.

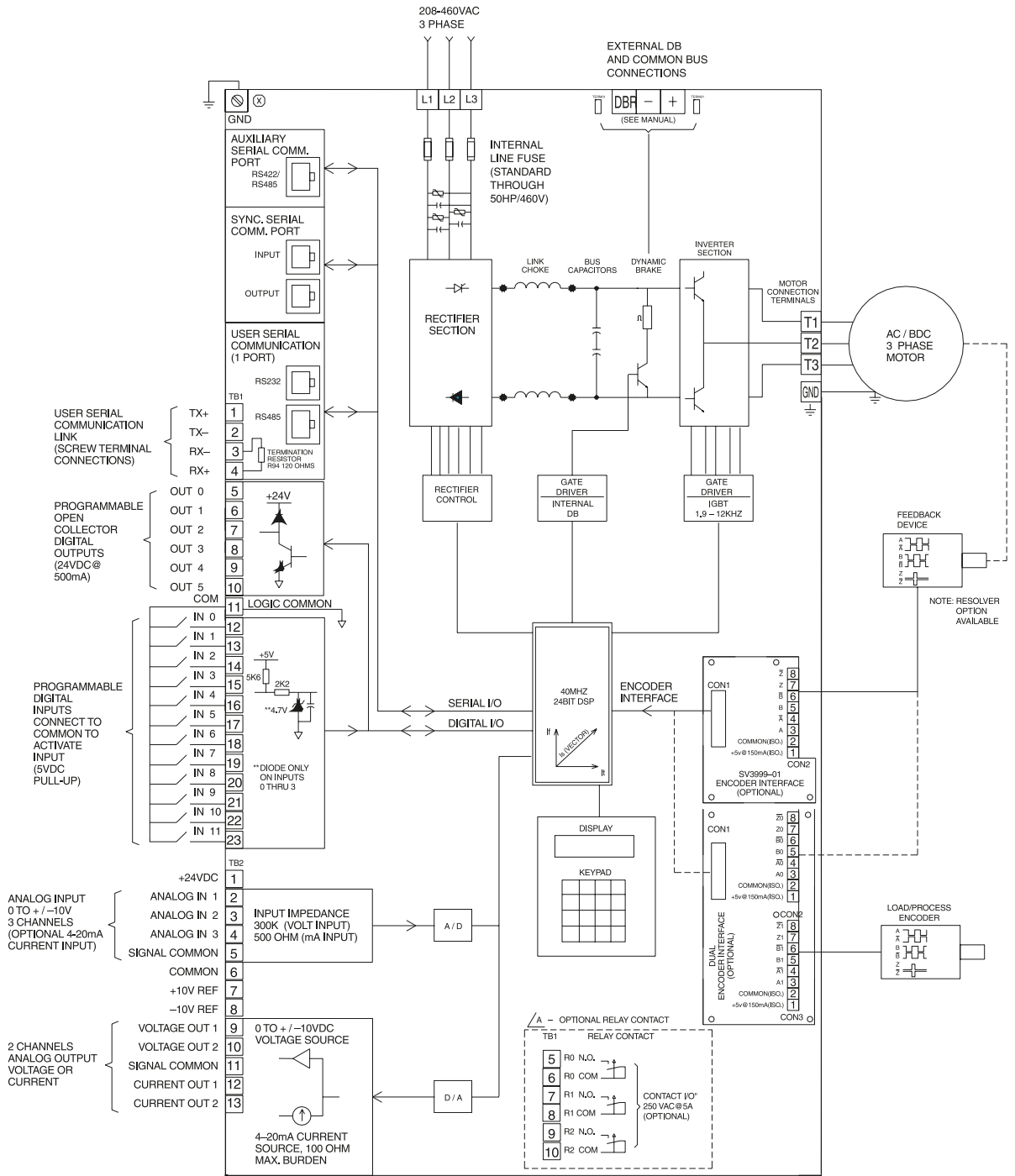

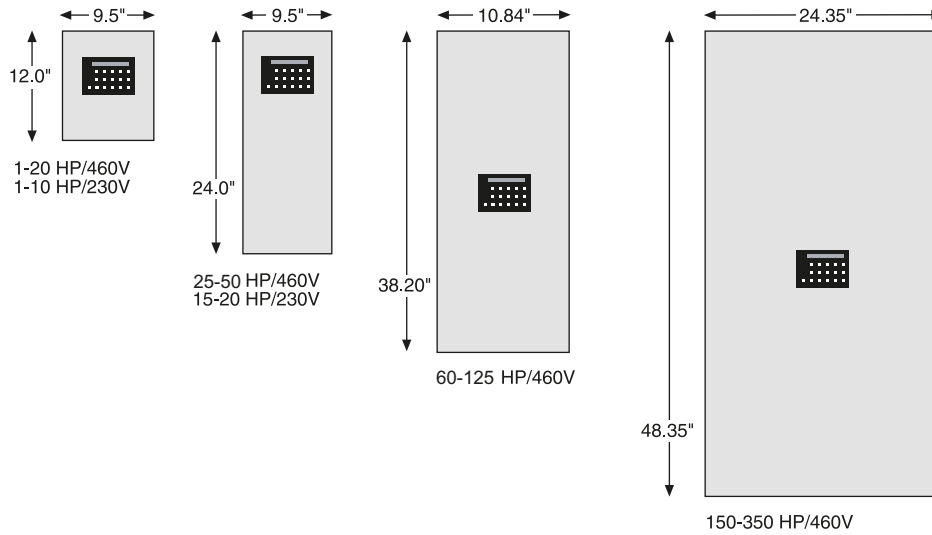

Rating	Voltage	Depth	Weight (Chassis)	Weight* (Encl)
1-5 HP	230/460	8.375"	9lb.	11lb.
7.5 HP	230/460	8.375"	13 lb.	16 lb.
10 HP	230	8.375"	18 lb.	21 lb.
15-20 HP	230	10.50"	30 lb.	35 lb.
10-15 HP	460	8.375"	18 lb.	21 lb.
20 HP	460	10.50"	22 lb.	25 lb.
25-50 HP	460	10.50"	35 lb.	40 lb.
60-125 HP	460	14.60"	114 lb.	114 lb.
150-350 HP	460	18.80"	390 lb.	475 lb.

\* weights are approximate

## How To Order - Model Number Specification

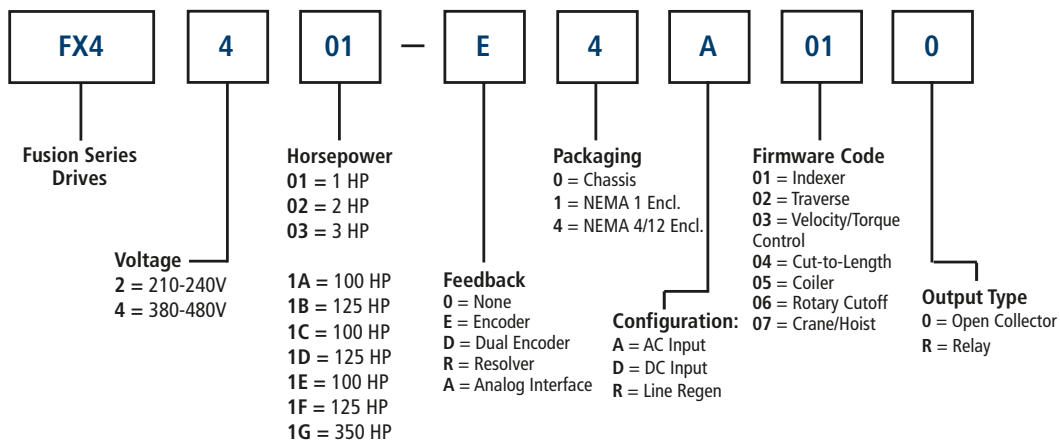

DANAHER MOTION is a trademark.

Danaher Motion makes every attempt to ensure accuracy and reliability of the specifications in this publication. Specifications are subject to change without notice. Danaher Motion provides this information "AS IS" and disclaims all warranties, express or implied, including, but not limited to, implied warranties of merchantability and fitness for a particular purpose. It is the responsibility of the product user to determine the suitability of this product for a specific application.

©2004 Danaher Motion.

## Vector Duty AC Motors - 230/460 VAC

SECO can provide vector duty motors to guarantee top performance of your FX4000. All motors are 1800 RPM base speed, and include thermostats. Motors with encoders are provided with 1024 PPR dual channel quadrature encoders with MS connector and mating plug. All motors are NEMA design "A" except 125 HP TEBC rating, and are not suitable for across-the-line starting.

Motors are provided with F1 conduit box location. For applications requiring speeds higher than base speed, please contact factory with details of load, coupling/belt method, and orientation. Shaded ratings are cast iron construction. Motors carry a 3 year warranty. Please consult factory for brake motors, explosion proof motors, and ratings not shown.

HP	Frame Size	Enclosure	80:1 Constant Torque Speed Range (No encoder)	Constant Torque to zero speed (Incl. encoder)	Breakdown Torque (lb-ft)	Rotor Inertia (lb-ft <sup>2</sup> )	Approx. Weight (lbs)
0.5	56C	TENV	MVM005	MVM005-01	5.8	0.056	28
1	56C	TENV	MVM01	MVM01-01	15.0	0.110	39
2	145TC	TENV	MVM02	MVM02-01	28.5	0.130	70
3	182TC	TENV	MVM03	MVM03-01	48.0	0.420	93
5	184TC	TENV	MVM05	MVM05-01	70.0	0.550	103
7.5	213TC	TENV	MVM07	MVM07-01	95.5	0.850	146
10	215TC	TENV	MVM10	MVM10-01	125.0	1.300	159
15	254TC	TENV	MVM15	MVM15-01	170.0	1.600	250
15	254TC	TEFC	MVMF15	MVMF15-01	108.0	2.200	339
20	256TC	TENV	MVM20	MVM20-01	290.0	3.100	320
20	256TC	TEFC	MVMF20	MVMF20-01	195.0	2.600	375
25	284TC	TENV	MVM25	MVM25-01	330.0	4.400	525
25	284T	TEFC	MVMF25	MVMF25-01	195.0	2.500	492
30	286TC	TENV	MVM30	MVM30-01	375.0	5.500	575
30	286T	TEFC	MVMF30	MVMF30-01	285.0	4.800	594
40	324TC	TEBC	MVM40	MVM40-01	320.0	5.000	620
40	324T	TEFC	MVMF40	MVMF40-01	320.0	5.000	540
50	326TC	TEBC	MVM50	MVM50-01	525.0	5.500	640
50	326T	TEFC	MVMF50	MVMF50-01	400.0	10.000	540
60	364TC	TEBC	MVM60	MVM60-01	525.0	14.500	1062
60	364T	TEFC	MVMF60	MVMF60-01	525.0	14.500	965
75	365TC	TEBC	MVM75	MVM75-01	645.0	16.000	1106
75	365T	TEFC	MVMF75	MVMF75-01	740.0	16.500	1006
100	405TC	TEBC	MVM100	MVM100-01	900.0	27.500	1429
100	405T	TEFC	MVMF100	MVMF100-01	900.0	27.500	1308
125	444T	TEBC	MVM125	MVM125-01	975.0	40.000	2110
125	444T	TEFC	MVMF125	MVMF125-01	1175.0	43.500	2062

\* weights are approximate

**NOTES:**

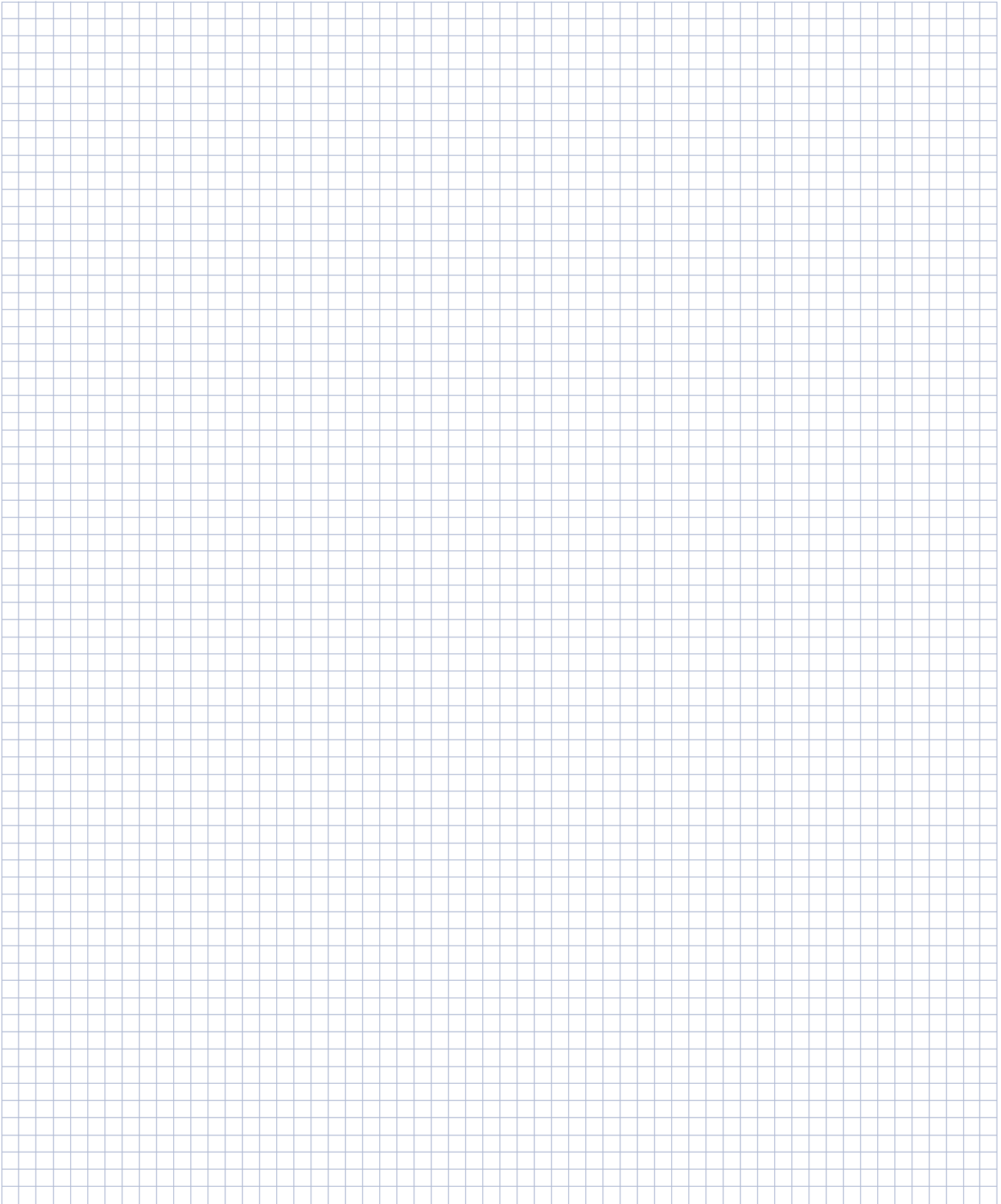

DANAHER MOTION is a trademark.  
DanaHer Motion makes every attempt to ensure accuracy and reliability of the specifications in this publication. Specifications are subject to change without notice. DanaHer Motion provides this information "AS IS" and disclaims all warranties, express or implied, including, but not limited to, implied warranties of merchantability and fitness for a particular purpose. It is the responsibility of the product user to determine the suitability of this product for a specific application.  
©2004 DanaHer Motion.

**NOTES:**

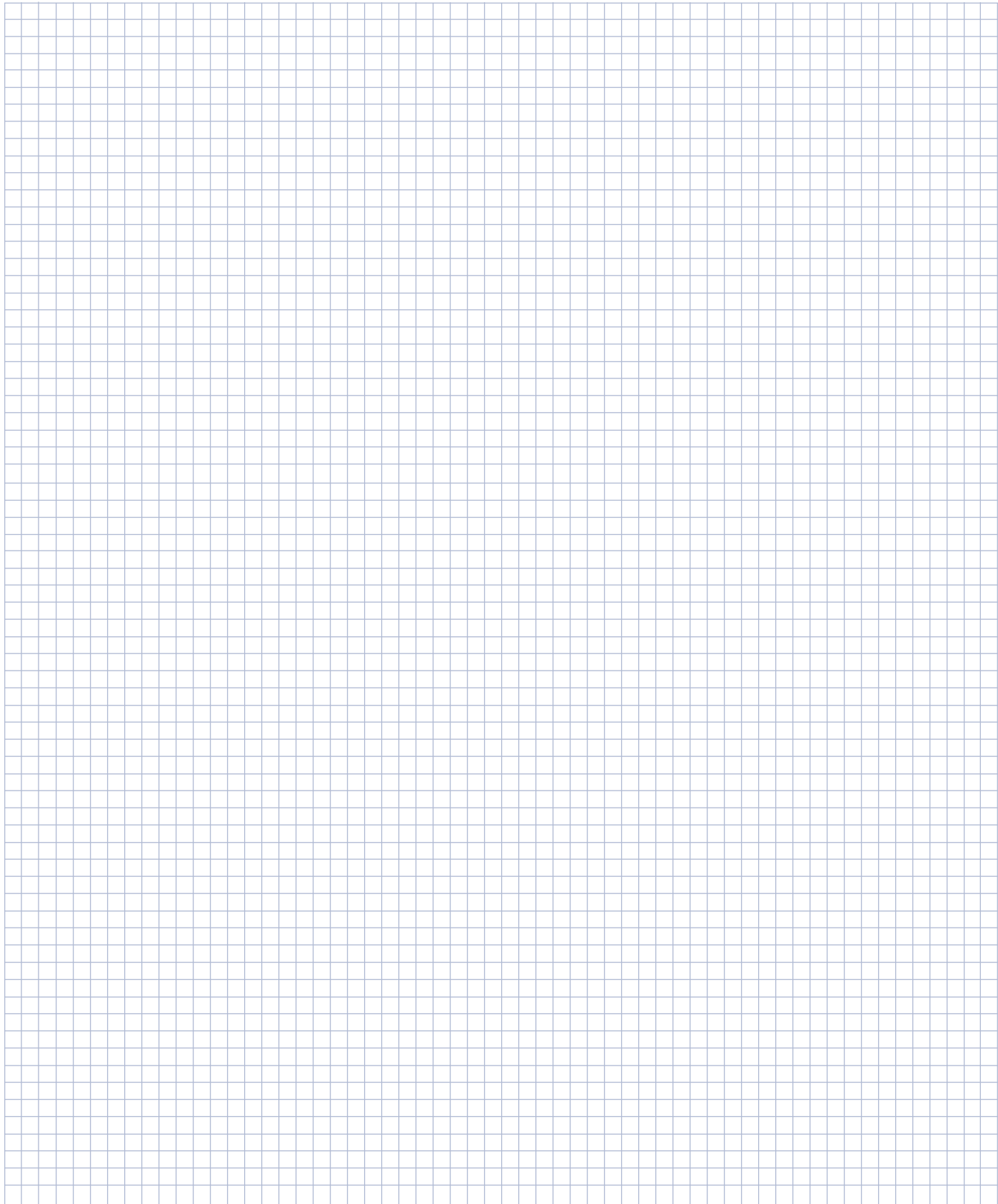

**NOTES:**

A large grid area for taking notes, consisting of a 30x30 grid of small squares.

DANAHER MOTION is a trademark.  
Danaher Motion makes every attempt to ensure accuracy and reliability of the specifications in this publication. Specifications are subject to change without notice. Danaher Motion provides this information "AS IS" and disclaims all warranties, express or implied, including, but not limited to, implied warranties of merchantability and fitness for a particular purpose. It is the responsibility of the product user to determine the suitability of this product for a specific application.  
©2004 Danaher Motion.

## Post-Project and Support Services

Danaher Motion has the staff, expertise, and subcomponent vendor qualification/certification capabilities to deliver your project on time. You also have the satisfaction of knowing that you have access to the following post-project services:

### Technical Support

Application engineers are available 24 hours a day, seven days a week to assist you with everything from parts replacement to dispatching a service engineer to handle emergency situations. We maintain a large stock of parts and sub-assemblies to provide you with quick turn-around of returned merchandise. In addition, our customers have access to free telephone product support.



### Training

Basic, intermediate and advanced classes, as well as configuration and programming training, can be provided at one of our facilities or at your facility. Witness testing can be provided at the Systems Center. Customized training for maintenance personnel can also be offered at your facility.



### Commissioning

Commissioning and start-up assistance typically includes the visual inspection of the installation to ensure proper connections to all drive components, verification of the drive components for proper set-up and calibration, operation of the drive system, and tuning of all drives. The engineer or technician also monitors the operation of your line once it is up and running, and makes final calibrations or adjustments as required for satisfactory operation.



### EMP

The EMP (Engined Motion Product) is a pre-packaged solution for linear/positioning applications. Features include: stepper or servo motion controller, rugged NEMA 12 enclosure, easy to install and commission, user-friendly operator interface.



# Danaher Motion Linear Motion Systems

As part of the Danaher Motion family, our mechanical and electro-mechanical product offerings include standard and custom linear bearings, shafting, linear guides, ball and lead screws, gearheads, linear actuators, slide tables and systems, precision balls, brakes and clutches, AC and DC adjustable speed drives, stepper and servo motors. Our products are applied worldwide throughout a variety of motion applications in the machine tool, medical, automotive, robotics, industrial, aerospace, office equipment and mobile off-highway markets. Our highly recognized brand names include: Thomson™, Micron™, Deltran PT™, Superior Electric™ and SECO™.



**Seco**  
AC/DC Drives

Solutions by  
**DANAHER**  
MOTION

DANAHER MOTION is a trademark.

Danaher Motion makes every attempt to ensure accuracy and reliability of the specifications in this publication. Specifications are subject to change without notice. Danaher Motion provides this information "AS IS" and disclaims all warranties, express or implied, including, but not limited to, implied warranties of merchantability and fitness for a particular purpose. It is the responsibility of the product user to determine the suitability of this product for a specific application.

©2004 Danaher Motion. HKM 10K KP 3-23-04 200312-10.qxd MDC-01-05-L106

## FOR IMMEDIATE ASSISTANCE:

Internet:	<a href="http://www.DanaherLinear.com">www.DanaherLinear.com</a>	In Europe:	Phone: ++46 (0) 44 24 67 00 Fax: +46 (0) 44 24 40 85 E-mail: <a href="mailto:helpdesk@tollo.com">helpdesk@tollo.com</a>
In USA, Canada or Mexico:	Phone: 1-800-554-8466 Fax: 1-800-445-0329 E-mail: <a href="mailto:linear@danahermotion.com">linear@danahermotion.com</a> Literature: <a href="mailto:litrequest@danahermotion.com">litrequest@danahermotion.com</a>	or write:	Danaher Motion Tollo Linear AB Box 9053 SE-291 09 Kristianstad Sweden
or write:	Danaher Motion 43-45 Channel Drive Port Washington, NY 11050 USA	or	Phone: +49 (0) 70 22 504-0 Fax: +49 (0) 70 22 541-88
In UK:	Phone: 0800 975 1000 Sales Fax: 0800 975 1001 E-mail: <a href="mailto:LMSEurope@danahermotion.com">LMSEurope@danahermotion.com</a>	or write:	Danaher Linear GmbH Nürtinger Strasse 70 D-72649 Wolfschlugen Germany
or write:	Danaher Linear Motion Systems Fishleigh Road, Roundswell Business Park Barnstaple EX31 3UD UK	Elsewhere:	Phone: 1 (516) 883-8937 Fax: 1 (516) 883-7109
Catalogue request:	<a href="mailto:catalogues@danahermotion.com">catalogues@danahermotion.com</a>		